



US 20200085310A1

(19) **United States**

(12) **Patent Application Publication**
ZAHNER et al.

(10) **Pub. No.: US 2020/0085310 A1**
(43) **Pub. Date: Mar. 19, 2020**

(54) **SENSOR UNIT FOR A PORTABLE
COMPUTER SYSTEM AND INTEGRATION
OF THE SENSOR UNIT**

(52) **U.S. Cl.**
CPC *A61B 5/01* (2013.01); *A61B 5/681*
(2013.01); *A61B 2562/0271* (2013.01); *G01K*
1/165 (2013.01); *A61B 5/0008* (2013.01);
G01K 13/002 (2013.01)

(71) Applicant: **greenTEG AG, Zürich (CH)**

(72) Inventors: **Michele ZAHNER, Zürich (CH);
Thomas HELBLING, Frauenfeld
(CH); Lukas DURRER, Ebnet-Kappel
(CH); Etienne SCHWYTER, Zürich
(CH)**

(57) **ABSTRACT**

The invention relates to a sensor unit (2) for determining the core body temperature by means of measured values which can be determined outside the body on a surface, comprising at least one heat flow sensor (20, 20'), and at least one temperature sensor (21, 21'), which can be easily compactly produced and installed and allows optimized determination of the core body temperature. This is achieved in that the sensor unit (2) comprises at least one monolithic heat flow sensor (20, 20') in the form of a sandwich-like structure consisting of multiple layers of different materials and at least one temperature sensor (21, 21'), which are soldered onto a circuit board (22) at a distance from one another or onto the circuit board (22) at the same height along a longitudinal direction of the circuit board (22), wherein the sensors (20, 21) are connected to an analog-to-digital converter (25) and a microcontroller (26) via wires or strip conductors, the electronic components (20, 21, 25, 26) can be connected to the electronics of a portable computer system by means of connecting wires (3), and the sensor unit (2) or the circuit board (22) with electronic components (20, 21, 25, 26) arranged thereon is at least partially enclosed by a sensor unit sleeve (28) in the transverse direction of the circuit board (22).

(21) Appl. No.: **16/470,877**

(22) PCT Filed: **Dec. 15, 2017**

(86) PCT No.: **PCT/EP2017/082994**

§ 371 (c)(1),
(2) Date: **Jun. 18, 2019**

(30) **Foreign Application Priority Data**

Dec. 21, 2016 (CH) 1695/16

Publication Classification

(51) **Int. Cl.**
A61B 5/01 (2006.01)
A61B 5/00 (2006.01)
G01K 13/00 (2006.01)
G01K 1/16 (2006.01)

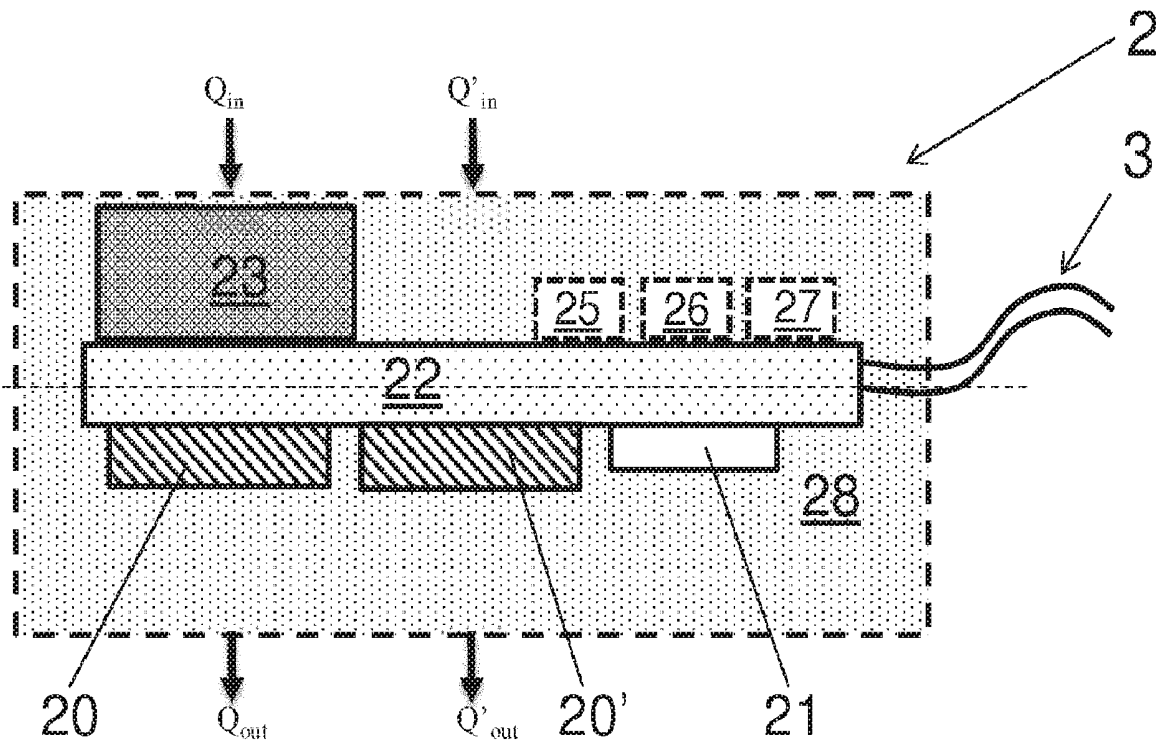

FIG. 1a

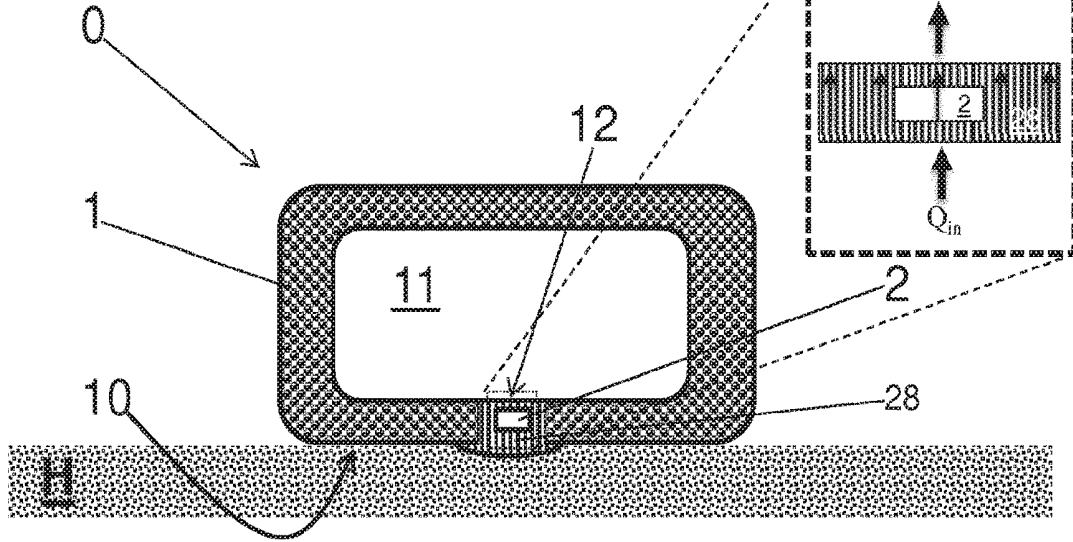

FIG. 1b

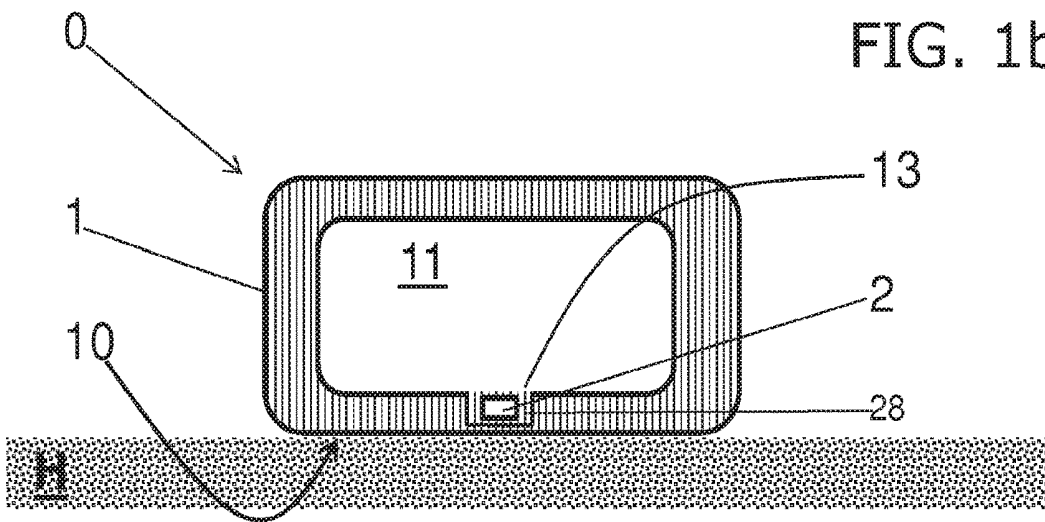

FIG. 1c

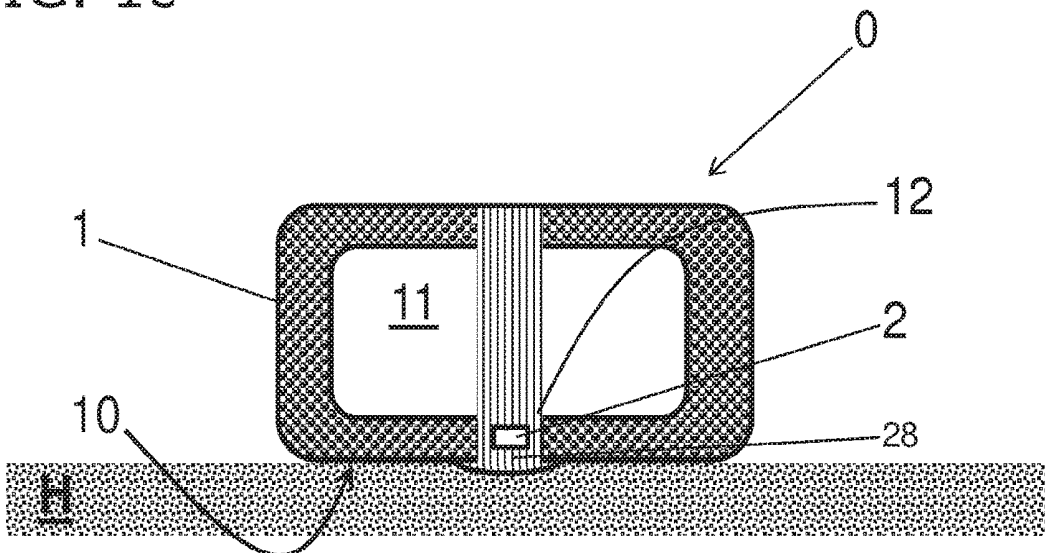

FIG. 2a

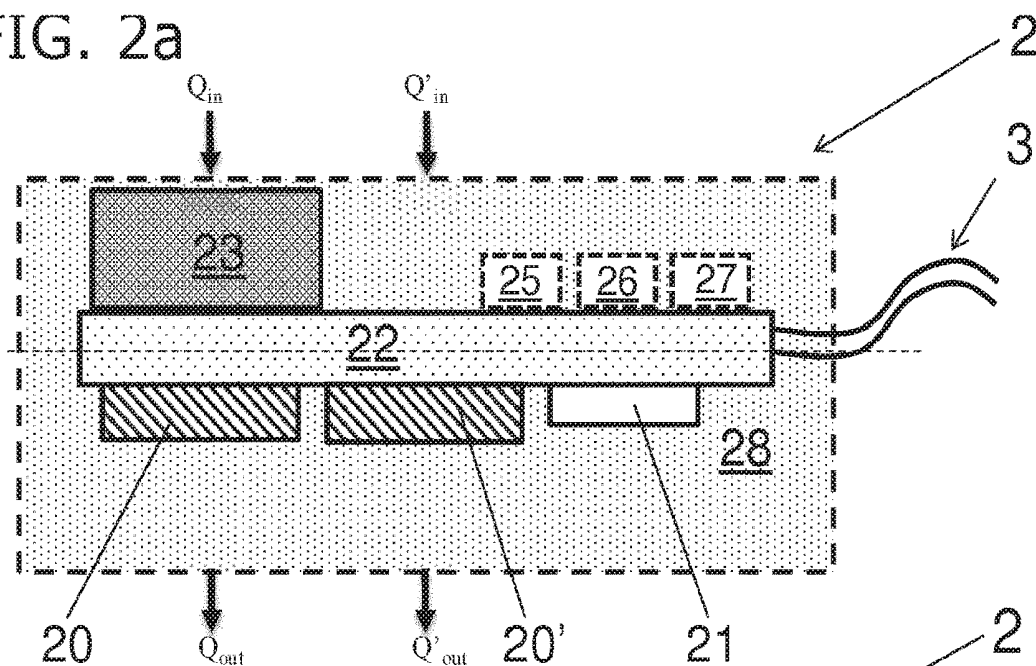

FIG. 2b

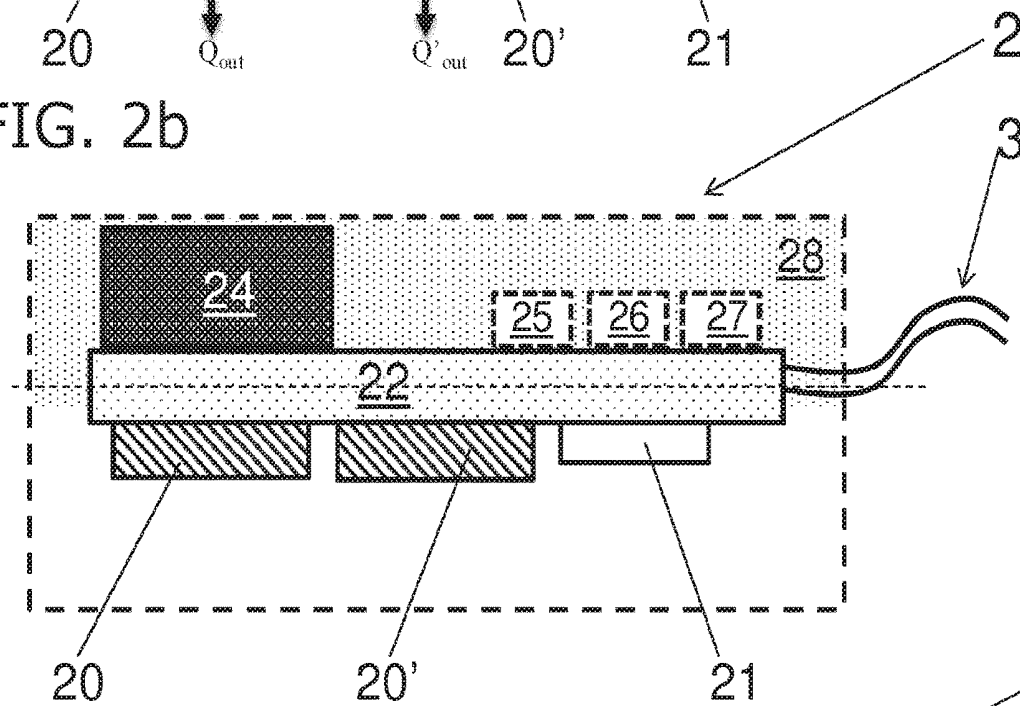

FIG. 2c

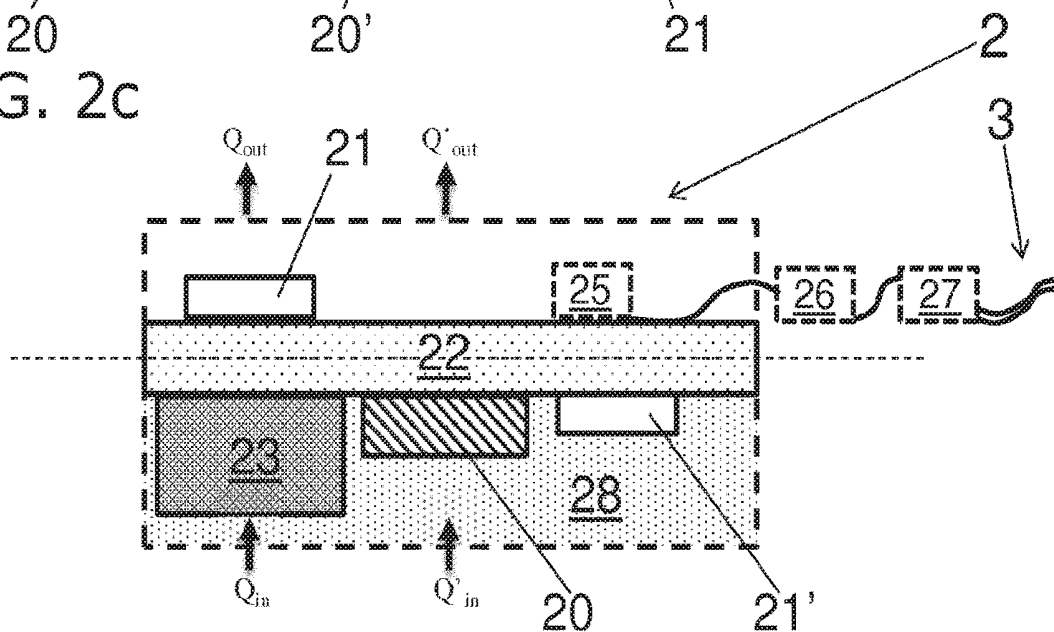

FIG. 2d

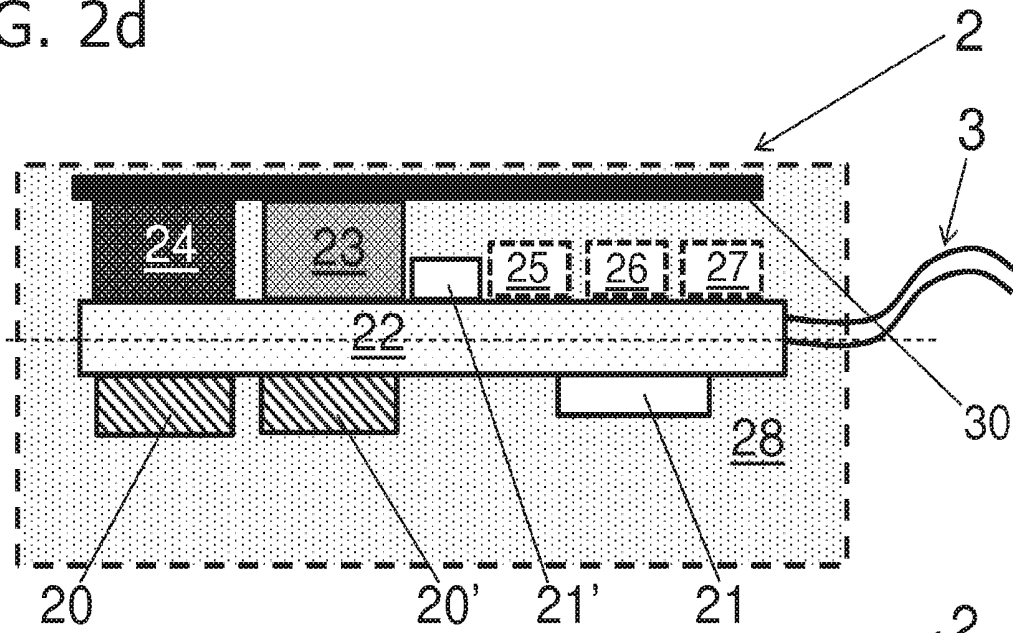

FIG. 2e

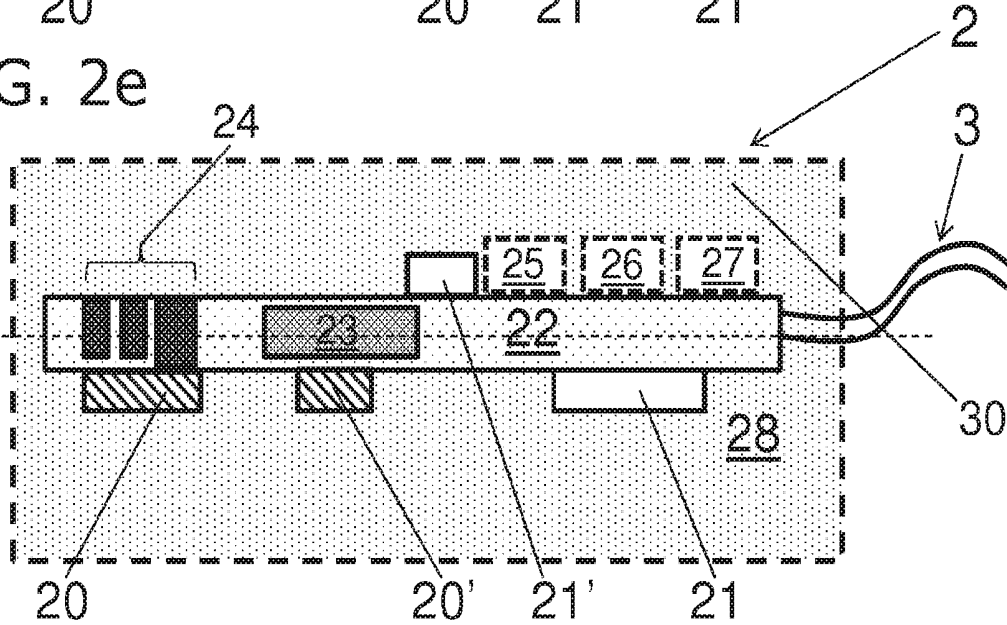

FIG. 2f

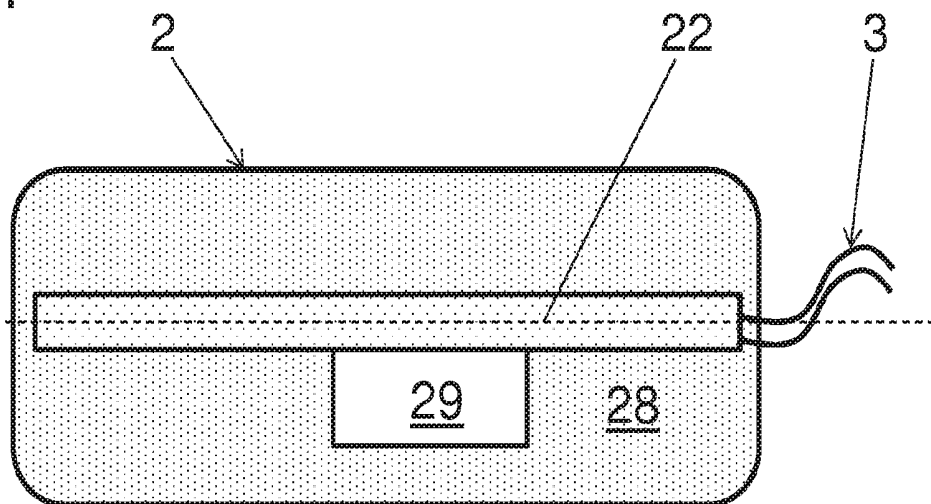

FIG. 3

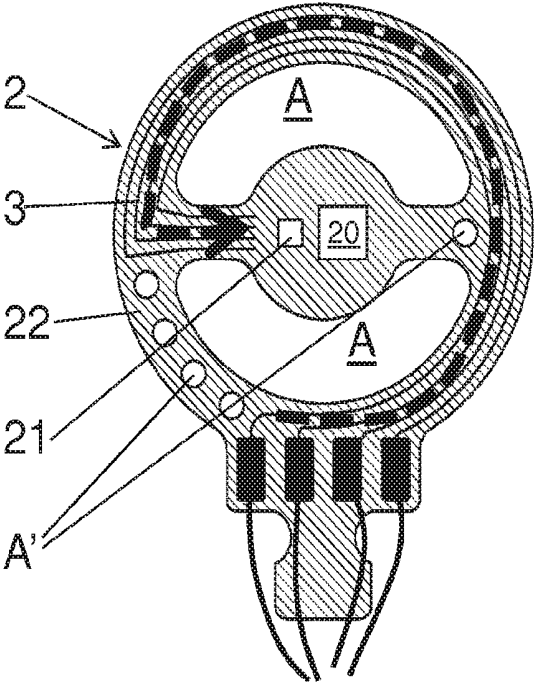

FIG. 4a

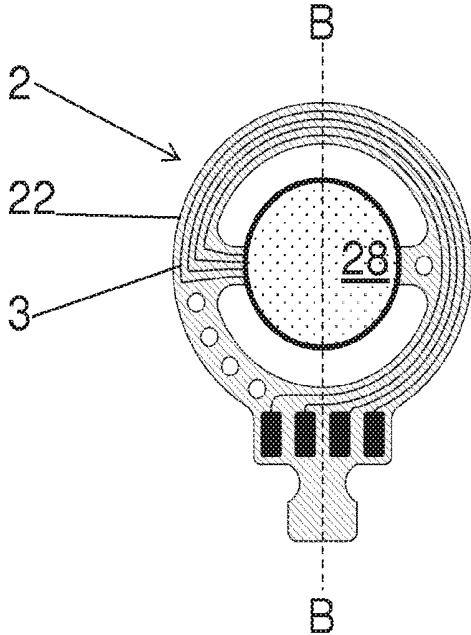

FIG. 4b

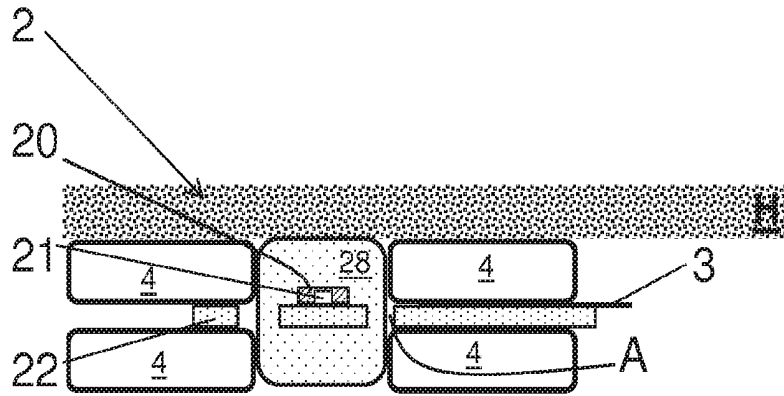

FIG. 5

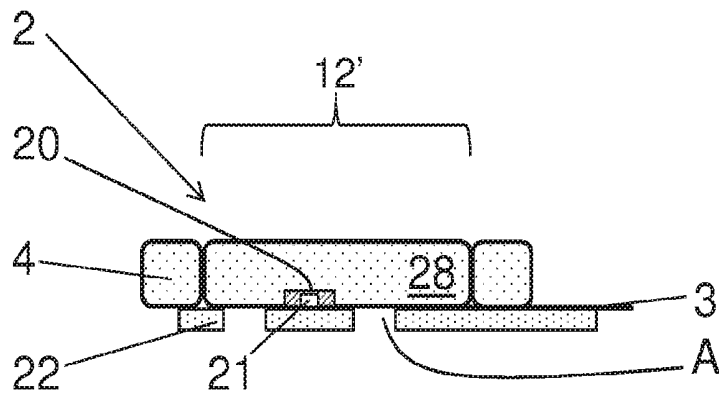

FIG. 6a

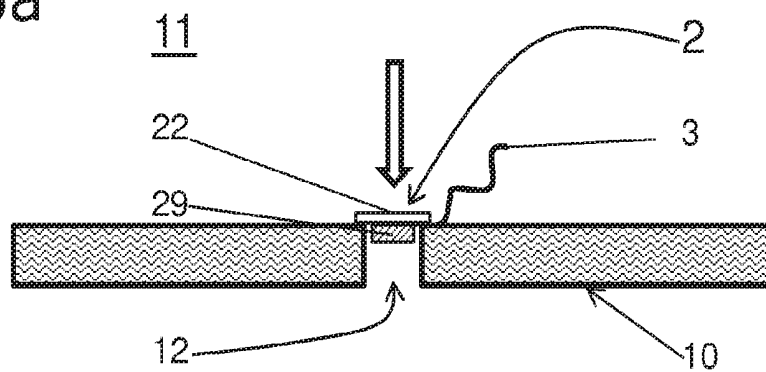

FIG. 6b

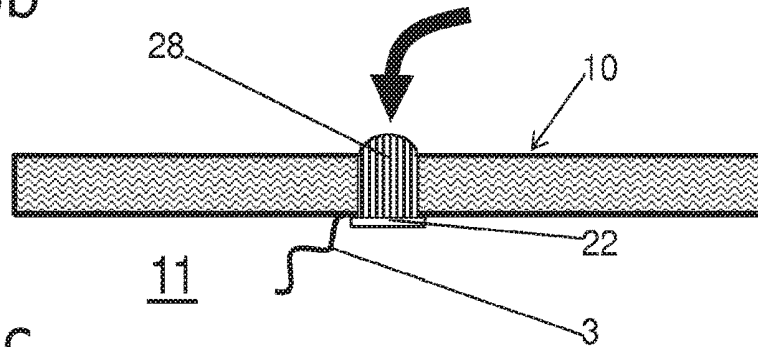

FIG. 6c

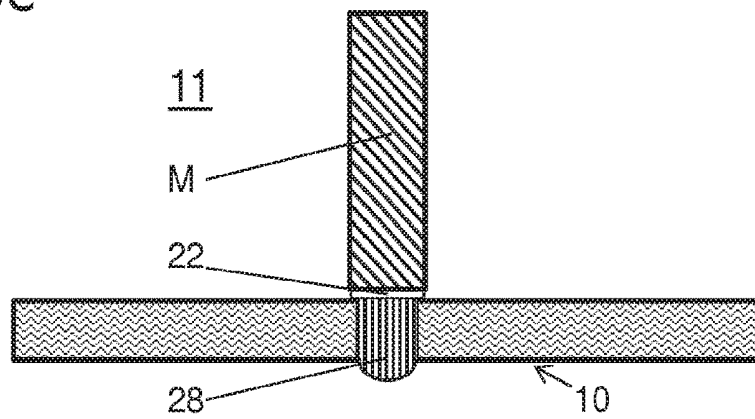

FIG. 7a

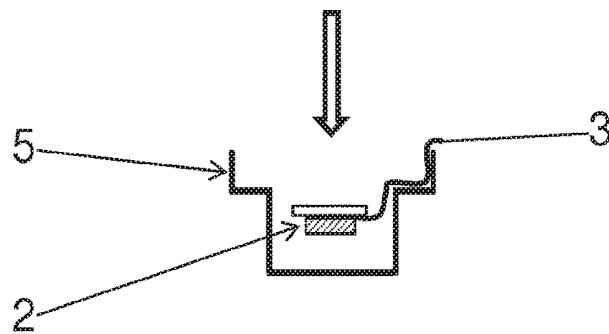

FIG. 7b

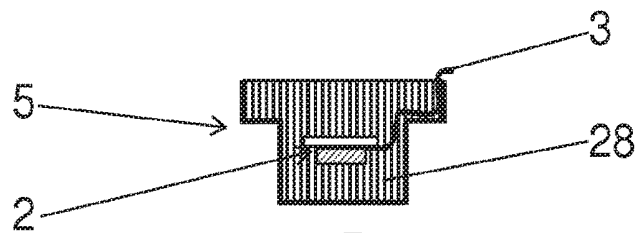
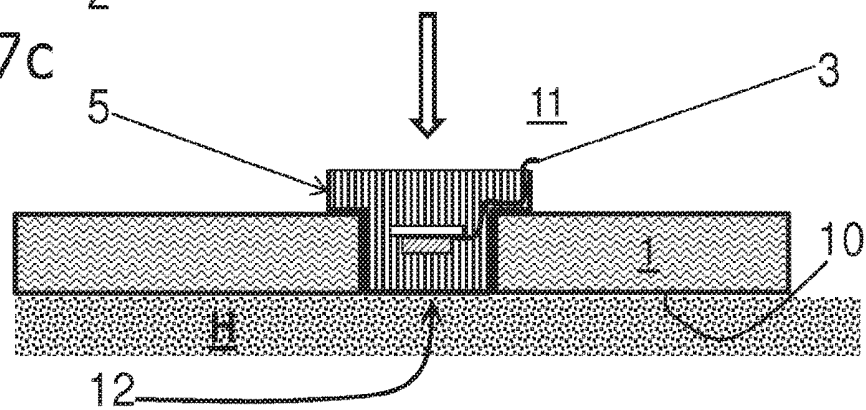

FIG. 7c



**SENSOR UNIT FOR A PORTABLE
COMPUTER SYSTEM AND INTEGRATION
OF THE SENSOR UNIT**

TECHNICAL FIELD

[0001] The present invention describes a sensor unit for determining the core body temperature by means of measured values, which can be determined outside the body on a surface, comprising at least one heat flow sensor and at least one temperature sensor, a portable computer system with a sensor unit, and the manufacture of a sensor unit comprising at least one measuring sensor and electronic components on a printed circuit board, and the integration of the sensor unit into a housing of a portable computer system, or into an adhesive pad for attachment onto the skin.

PRIOR ART

[0002] Portable technical data processing devices with measuring capabilities are of known art in various configurations, with or without a housing, as parts of clothing, or in the form of jewelry. These portable computer systems or wearable computers are the subject matter of the research field "wearable computing". The wearable computers or portable computer systems have at least one sensor unit, with which data is collected via at least one sensor from the real world. The measured data is then either processed in the portable computer system itself or transferred to another computer, in particular to a smart phone. The user can view the recorded data and process it further. The portable computer system comprises a housing, in which a sensor unit and electronics are integrated. As a rule the electronics have at least one microcontroller and one read-out/storage unit, which are connected to the sensor unit.

[0003] One example of a wearable computer, or portable computer system, is an activity tracker, also called a fitness or health armband, smart band, or fitness tracker. Using software operated in the electronics, data from at least one sensor of the sensor unit are collected, further processed, stored in a memory as necessary, and/or forwarded to a smart phone. Accordingly, data relevant to fitness and health, such as running distances, energy consumption, and also, in some cases, heart rate, body temperature, oxygen content in the blood, or sleep quality, can be determined.

[0004] Here the determination of the internal body temperature, or core body temperature, by means of a portable computer system is of interest. The non-invasive and continuous determination of internal body temperature, as measured on the skin, is important for patient monitoring in hospitals, for the prevention of heat stroke in athletes, or for the determination and monitoring of the circadian cycle for the diagnosis of sleep disorders and other illnesses.

[0005] In the simplest case, the sensor unit of the portable computer system is based on a temperature sensor to determine the skin temperature in combination with thermal insulation over the sensor and its surroundings. The purpose of the insulation is to keep the skin temperature as close as possible to the core body temperature. In many cases the method is inaccurate and unsuitable for use under changing external conditions.

[0006] To improve the measurement of the core body temperature, the sensor unit of the portable computer system may include a so-called double temperature sensor, as recorded in DE10038247. Here two temperature sensors are

separated from one another by a thermal insulator with a known thermal resistance. In most cases this method requires a calibration measurement so as to determine the thermal resistance, which depends on the person and also the location of the measurement.

[0007] The double sensor method has multiple disadvantages. One severe problem is represented by the thermal parasitic heat losses between the two temperature sensors, which can lead to strong deviations. These must be resolved by thermal insulation and by complex compensation algorithms, as described in DE102005004933. Another disadvantage lies in the size of the system. In order to achieve good sensitivity, the temperature difference in application must be sufficiently large, which means that the material between the two temperature sensors must have a certain minimum thickness. This makes the sensor system rather chunky and bulky and less suitable for ease of integration into housings of prior art.

[0008] The sensor units of known art for determining the core body temperature are not yet suitable for ease of integration into the housing of a portable computer system. In order to avoid parasitic heat losses, thermal insulators and additional structures are required, resulting in a complex design, and making it difficult to integrate the sensor unit into the housing of a portable computer system. A further disadvantage is the measurement inaccuracy of the sensor units of known art when determining the core body temperature.

[0009] WO02078538 presents the determination of the core body temperature with the aid of a heat flow sensor, which is attached to the skin of a user. The heat flow sensor forms part of a sensor unit, which here too must be attached in a complex manner to a computer system. In

[0010] WO2005092177 another sensor unit is described that is suitable for the measurement of the core body temperature, which comprises, amongst other items, a heat flow sensor, and can likewise be connected to a portable computer system. This has brought us closer to the goal of determining the core body temperature as accurately as possible, but the manufacture of the sensor unit and the integration of the sensor unit in the portable computer system remains complicated and cumbersome.

PRESENTATION OF THE INVENTION

[0011] The object of the present invention is that of creating a compact sensor unit that can easily be installed, either for installation in a portable computer system, or for mounting on or in an adhesive pad, which allows an optimised determination of the core body temperature.

[0012] An opportunity is created, by which to simplify the manufacture of the sensor unit, and to simplify the attachment of the sensor unit onto or into a housing of a portable computer system, or onto or into an adhesive pad.

[0013] With the sensor unit as presented thermophysiological data on a body, especially the internal body temperature, or core body temperature, can be measured, whereby heat flows and surface temperatures are determined. Other parameters can be: the heat output of the skin, calorie consumption, calorie intake, blood pressure, blood sugar, internal temperature at a particular point on the body, compensated skin temperature, etc.

[0014] In particular, a method is described that allows the coupling of a sensor unit to a housing of a portable computer

system, or its attachment onto or into an adhesive pad, or by means of a tape, with a few operative steps.

BRIEF DESCRIPTION OF THE FIGURES

[0015] Further features, details and advantages of the invention ensue from the following description of preferred embodiments of the invention, together with the figures. Here:

[0016] FIGS. 1a to 1c show schematic cross-sectional views of portable computer systems with integrated sensor units.

[0017] FIGS. 2a to 2e show schematic cross-sectional views of various sensor units.

[0018] FIG. 2f shows a schematic cross-sectional view of a sensor unit, wherein the electronic components, encapsulated in an integrated circuit (IC), are aggregated in a chip housing.

[0019] FIG. 3 shows a plan view of a sensor unit before the attachment of a sensor unit sleeve.

[0020] FIG. 4a shows a plan view onto the sensor unit shown in FIG. 3 after attachment of the sensor unit sleeve, while FIG. 4b shows a schematic cross-sectional view of the sensor unit shown in FIG. 4a along the B-B cross-sectional line.

[0021] FIG. 5 shows a schematic cross-sectional view of a sensor unit with a sensor unit sleeve in a cavity in an adhesive pad.

[0022] FIG. 6a shows a schematic cross-sectional view of the fixation of a sensor unit to a housing, while

[0023] FIG. 6b shows a schematic cross-sectional view of the sensor unit after the filling of a through hole, and

[0024] FIG. 6c shows a schematic cross-section after the attachment of a metal rod to the sensor unit.

[0025] FIG. 7a shows a schematic cross-sectional view of a first step of a manufacturing method for a sensor unit, while

[0026] FIG. 7b shows a schematic cross-sectional view of a sensor unit encapsulated in a sensor unit sleeve, and

[0027] FIG. 7c shows a schematic cross-sectional view of the encapsulated sensor unit shown in FIG. 6b, after it has been pressed into a cavity in a housing of a portable computer system, and has been brought into contact with the skin of a user.

DESCRIPTION

[0028] A portable computer system 0 is here represented in the form of an armband having a hollow interior 11 with a housing 1. The housing 1 is laid, with a skin contact side 10, onto the skin H of a user. A heat flow occurs from the body of the user, across the skin H, crossing the housing 1 of the portable computer system 0, into the interior 11; in the detail of FIG. 1a the heat flow through the housing 1 is marked as Q_{in} to Q_{out} . People and animals are possible users.

[0029] A sensor unit 2, which is specified in more detail below, is inserted into the housing 1, detachably or non-detachably attached, and electrically connected to the electronics (not shown) of the portable computer system 0. The sensor unit 2 is at least partially surrounded by a sensor unit sleeve 28 and is pressed into the housing 1, that is to say, it is bonded in with adhesive, or encapsulated. The sensor unit sleeve 28 is manufactured from a thermally conductive material, in particular silicone. By using a material with a similar thermal conductivity to that of the heat flow sensor

itself, as described later, it is possible to homogenise the heat flow and thus minimise parasitic heat flows. Furthermore, a good thermal conductivity means that the temperature measured is closer to the skin temperature. The conductivity of the sensor unit sleeve 28 in our case should lie between 0.3 and 10 W/mK; optimally between 0.8 and 3 W/mK. For metrological reasons, the sensor unit 2 should be located as close as possible to the user's skin, but in principle can be arranged anywhere in the heat path.

[0030] In the embodiment as shown in FIG. 1a a through hole 12 is provided, which crosses the housing 1 completely, into which a completely encapsulated sensor unit 2 is inserted. The sensor unit sleeve 28 protrudes slightly from the through hole 12 and from the skin contact side 10, and when in use comes into contact with the skin H of the user. The heat flow from the skin H, and thus from the body, via the skin, through the sensor unit sleeve 28 and the sensor unit 2, adjusts itself during use, and can be used to determine the core body temperature.

[0031] As shown in FIG. 1b, a cavity in the form of a blind hole 13 can also be arranged in the housing 1 of the portable computer system, into which the sensor unit 2 with a partially surrounding sensor unit sleeve 28 is introduced. Here too the sensor unit 2 including the sensor unit sleeve 28 is inserted into the blind hole 13 in the form of a plug, and is thus detachably connected to the housing 1.

[0032] To increase the stability of the mounting of the sensor unit 2 with the sensor unit sleeve 28 in the housing 1, the sensor unit sleeve 28 can extend across the housing 1, as shown in FIG. 1c. This creates a thermal path such that the thermal equilibrium between the environment and the body adjusts itself as quickly as possible. Accordingly, the sensor unit sleeve 28 extends from the skin contact side 10 to a side of the housing 1 remote from the skin contact side 10, and thereby crosses the housing 1.

[0033] FIGS. 2a to 2d show embodiments of the sensor units 2 for determining the core body temperature. The aim is to create a sensor unit 2 that is as compact as possible, mechanically robust, and in the best case is flexibly configured.

[0034] The basis of the sensor unit 2 is a printed circuit board 22, onto which at least one heat flow sensor 20 and at least one temperature sensor 21 are soldered. The printed circuit board 22 can be executed in a rigid or flexible manner, and, in addition to strip conductors made from an electrical conductor, comprises insulating material, preferably a fibre-reinforced plastic. Optimally, the material of the at least one printed circuit board 22 has a thermal conductivity of between 0.3 and 10 W/mK, and preferably between 0.8 and 3 W/mK, such that a homogeneous heat flow is guaranteed.

[0035] The various sensors 20, 21 are placed on soldering surfaces on the printed circuit board 22 and attached with solder. The at least one heat flow sensor 20 and the at least one temperature sensor 21 are arranged spaced apart from one another along a longitudinal direction. The heat flow sensor 20 and the temperature sensor 21 are attached onto the same side of the printed circuit board 22.

[0036] Other components, in particular blocks made from thermally insulating materials 23 and thermal capacitances 24, are also attached onto the printed circuit board 22. The thermal insulator 23 and the thermal capacitance 24 are

bonded to the printed circuit board 22 with an adhesive such as an acrylic, epoxy or polyurethane or, if the material permits, are soldered on.

[0037] In order to keep the thermal transfer resistance between components as low as possible, for example between the heat flow sensor 20 and the thermal capacitance 24, a thermally conductive adhesive should be used in the case of adhesive bonding.

[0038] Electronic components such as an analogue-to-digital converter 25, a microcontroller 26, and a read-out/storage unit 27, can also be attached onto the printed circuit board 22 in an electrically conductive manner. To achieve sufficiently high measurement signals, however, it is sufficient to attach only the analogue-to-digital converter 25 onto the printed circuit board 22, and to arrange the microcontroller 26 and the read-out/storage unit 27 at a distance from the printed circuit board 22 by means of wires or so-called flex-rigid printed circuit boards, a layered arrangement of plastic and copper layers, which form a flexible composite printed circuit board.

[0039] Connecting wires 3 are arranged leading away from the printed circuit board 22; these transmit the measured signals, or processed signals, to the electronics of the portable computer system 0. Optionally, the connecting wires 3 can also be formed by flexible printed circuit boards or strip conductors, to which the electronic components can be connected.

[0040] In order to increase the stability of the sensor unit 2 and to achieve a homogeneous heat flow, the printed circuit board 22, populated with the components, is at least partially surrounded by the sensor unit sleeve 28. While the variants shown in FIGS. 2a and 2d show a sensor unit 2 completely encapsulated in a sensor unit sleeve 28, the other embodiments here are only provided with a sensor unit sleeve 28 on their side of the sensor unit 2 that subsequently faces towards the skin H.

[0041] The sensor unit sleeve 28 does not necessarily have to consist of only one material. For example, a silicone that is more compatible with the skin can be arranged adjacent to the skin, and a thermally conductive silicone can then be applied up to the printed circuit board 22. The printed circuit board 22 itself has a thermal conductivity that is similar to that of the sensor unit sleeve 28. Above the printed circuit board 22 there is another 0.5 cm of thermally conductive silicone, and then a metal rod, or a silicone-filled metal rod, up to the top of the housing. Tests have shown that it does not matter whether the at least one heat flow sensor 20 and the at least one temperature sensor 21 are located on the same side of the printed circuit board 22, or on opposite sides. The measurements of the heat flow, using the heat flow sensor 20, and the temperature, using the temperature sensor 21, are used to determine the actual core body temperature.

[0042] In FIG. 2a the sensor unit 2 has two heat flow sensors 20, 20' and one temperature sensor 21, soldered to the skin-facing side of the printed circuit board 22. Here a thermal insulator 23 is attached, at the height in the longitudinal direction of a heat flow sensor 20, on the side of the printed circuit board 22 that is free of heat flow sensors. In the variant shown in FIG. 2b, a thermal capacitance 24 is attached, at the height in the longitudinal direction of a heat flow sensor 20, on the side of the printed circuit board 22 that is free of heat flow sensors. In this manner a heat flow is measured through a first heat flow sensor 20 and a thermal

insulator 23, or a thermal capacitance 24, as is a heat flow through a second heat flow sensor 20'. The two measured values, together with the measurement of the temperature by means of the temperature sensor 21, enter into the determination of the core body temperature. In accordance with a prior calibration of the heat flow sensor measurement with and without the thermal insulator 23 or the thermal capacitance 24, the determination of the core body temperature can be optimised.

[0043] The thermal insulator 23 has a high thermal resistance, whereby the thermal conductivity λ of the material of the thermal insulator 23 is very low. As shown in FIG. 2a, the heat flow through the first heat flow sensor 20 differs from the heat flow through the second heat flow sensor 20' by virtue of the thermal insulator 23. A foamed plastic material is used as the thermal insulator 23, whereby the heat flow through the first heat flow sensor 20 is less than that through the second heat flow sensor 20'. The decisive factor is the difference between the two heat flows, from which the core body temperature can be better determined, with the aid of an algorithm. This design ensures that the sensor unit 2 is more robust with respect to changes in the thermal coupling between the sensors 20, 20', 21, 21' and the skin H. The heat flow difference is taken into account in the determination, for which reason the properties of the thermal insulator 23 must be known and experimentally determined and calibrated. The thermal conductivity λ of the thermal insulator material 23 should be of the order of that for air ($\lambda_{air}=0.024$ W/m/K), i.e. between 0.01 W/m/K and 0.1 W/m/K.

[0044] Materials for the sensor unit sleeve 28 can include polymers such as polypropylene, PES, PE, PET, polyethylene, acetal, nylon, polybutylene terephthalate, polysulfone, PPS, polycarbonate, Teflon, polyester, PMMA, PSU, PEEK, TPE, TPU, parylene or PTFE. Ethylene-propylene-diene rubber (EPDM) and polypropylene have preferably been chosen. The at least one printed circuit board 22, that is to say, the material of the printed circuit board 22, can also be part of the sensor unit sleeve 28. FR-4 or FR4, a composite material of epoxy resin and glass fibre fabric, can, for example, be used as the material for the printed circuit board 22. As of known art to the person skilled in the art, the thermal conductivity of the materials can be improved or adapted by a specialised form of manufacture (e.g. by the addition of particles) such that the material has a similar thermal conductivity to that of the sensor unit itself.

[0045] Accordingly, the thermal capacitance 24 has a very low thermal resistance and the material has a very high thermal conductivity, that is to say, a very high value of λ . The thermal capacitance 24 should absorb the heat to the maximum extent. Here too, the heat flow through the first heat flow sensor 20 differs from the heat flow through the second heat flow sensor 20'. Thermally conductive silicone has been successfully used as the material. However, metals can also be used. The thermal conductivity λ of the material of the thermal capacitance 24 should be significantly higher than the thermal capacitance of air ($\lambda_{air}=0.024$ W/m/K), i.e. greater than 0.1 W/m/K.

[0046] The thermal insulator 23 and the thermal capacitance 24 are attached to the printed circuit board 22 with a suitable adhesive. If copper or brass is used, this can be soldered onto the printed circuit board 22.

[0047] The variant depicted in FIG. 2c shows a heat flow sensor 20 and two temperature sensors 21, 21', whereby a thermal insulator 23 is attached onto the heat flow sensor

side of the printed circuit board **22**, which is located opposite the temperature sensor **21'** at the same height in the longitudinal direction of the printed circuit board **22**. The temperature sensor **21** is connected directly to the printed circuit board **22**, but is spaced apart from the thermal insulator **23**. This allows two different temperature measurements by means of the two temperature sensors **21**, **21'** arranged at a distance from one another in the longitudinal and transverse directions.

[0048] The electronic components of the sensor unit **2**, the at least one heat flow sensor **20**, the at least one temperature sensor **21**, the analogue-to-digital converter **2b**, the microcontroller **26** and the read-out/storage unit **27**, encapsulated in an integrated circuit **29** (IC), can be aggregated in a chip housing, and, together with the printed circuit board **22**, form the sensor unit **2**. In practice, the encapsulation is achieved either by the application of adhesive to both sides, or by a casting process. The integrated circuit **29**, that is to say, the chip housing, is soldered onto the printed circuit board **22**. By virtue of the compact design of the integrated circuit **29**, the manufacture of the sensor unit **2** can be simplified even further. FIG. **2d** shows a sensor unit **2**, whereby the two heat flow sensors **20**, **20'** are soldered onto the same side of the at least one printed circuit board **22**, spaced apart from one another in the longitudinal direction. A thermal capacitance **24** is arranged on the side of at least one printed circuit board **22** that is free of heat flow sensors, at the height of the first heat flow sensor **20** in the longitudinal direction. In addition, a thermal insulator **23** is arranged on the side of the at least one printed circuit board **22** that is free of heat flow sensors, at the height of the second heat flow sensor **20'** in the longitudinal direction. On the side that is free of heat flow sensors, a metal plate **30** is arranged so as to be in contact with the thermal insulator **23** and the thermal capacitance **24**, and running parallel to the printed circuit board **22**. The metal plate **30** can also be arranged so as to be in contact with, and/or partially covering, a block made from a thermally conductive material on the printed circuit board **22**, or the sensor unit sleeve **28**. By means of the metal plate **30**, which is preferably made from aluminium and can be rigid or flexible, a thermal equilibrium is achieved with the same external temperature along the metal plate **30**, and the measuring accuracy can be increased.

[0049] Since the aim should be to save space with the integration of the sensor unit, especially in ears, the configuration of the thermal insulator **23** and/or the thermal capacitance **24** can be modified. Here the thermal insulator **23** or the capacitance **24** does not have to be arranged on the printed circuit board **22**, but can also be incorporated into the latter. Here, for example, a thermal insulator **23** is shown running within the cross-section of the printed circuit board **22**, whereby this thermal insulator can be an insulating layer, for example an air pocket. The thermal conductivity is increased by introducing thermovias, for example Cu vias, which are configured as thermal capacitances **24** in the form of blind holes, or through holes, filled with copper. In addition, a thermal capacitance **24** could also be designed as concealed thermovias, so-called "buried vias", which are not shown here.

[0050] As shown in FIG. **2f**, the printed circuit board **22**, together with the integrated circuit **29**, is almost completely surrounded on both sides by the sensor unit sleeve **28**.

Connection of the connecting wires **3** to the electronics of a portable computer system **0** is readily possible.

[0051] Deployable heat flow sensors **20**, **20'**, which in particular can be soldered onto the printed circuit board **22**, can be found in EP2938980 and WO2016128247 of the applicant, the contents of which are referenced here. Miniaturised and/or thin monolithic heat flow sensors with low thermal invasiveness can be deployed, which are mechanically sufficiently robust and can be soldered onto the surface of the printed circuit board **22**. A sandwich-like structure, consisting of multiple layers of different materials, including metals and at least one electrically insulating matrix layer, is selected for this purpose. Such a monolithic heat flow sensor **20**, **20'** forms a closed body on at least one side and a number of sensing junctions between different metal layers. Temperature sensors **21** have been of known art for a long time, and variously configured temperature sensors **21** can be used. All temperature sensors **21** of known art that can be soldered onto the printed circuit board **22**, or onto another printed circuit board, can be used as the temperature sensors **21**. Amongst others, infrared sensors can be used for temperature measurement; these must not be surrounded by a sensor unit sleeve **28**. In a preferred embodiment, the sensor unit **2** comprises multiple printed circuit boards **22**, whereby the at least one heat flow sensor **20**, **20'** is arranged on one printed circuit board **22**, and an infrared sensor for purposes of temperature measurement is arranged on another printed circuit board, which is arranged spatially separated from the first printed circuit board **22**. By means of appropriate wiring, measured values from at least one heat flow sensor **20**, **20'** on the first printed circuit board **22**, and measured values from the infrared sensor on the second printed circuit board, can be processed in the read-out/storage unit **27**. Although the infrared sensor is part of the sensor unit **2**, it must remain free of the sensor unit sleeve **28**. The easiest way to achieve this is to arrange the infrared sensor on the second circuit board.

[0052] FIG. **3** shows a sensor unit **2** with a partially round printed circuit board **22**, or more particularly, a partially round cross-sectional area with cavities **A** in a plan view onto the side of the sensor that subsequently faces the skin surface. For the sake of simplicity, a sensor unit sleeve **28** is omitted here, so that the heat flow and temperature sensors **20**, **21** protruding from the side of the sensor are visible. The strip conductors on the printed circuit board **22** run along a circular path that is as long as possible, as indicated by the dashed arrow, along the printed circuit board **22** to the temperature sensor **21** and the heat flow sensor **20** in the centre of the printed circuit board **22**. This virtually prevents any thermal heat loss or any interfering heat input caused by heat conduction from the connecting wires **3**.

[0053] In particular, by the arrangement of the two kidney-shaped cavities **A**, in each case adjacent in the longitudinal direction to the heat flow and temperature sensors **20**, **21**, bordering a bridge, whereby a central printed circuit board disk is formed, a thermally-undisturbed mounting of the temperature sensor **21** and the heat flow sensor **20** is achieved. By virtue of the cavities **A'** in the edge region, any interfering heat flow between the contacts of the connecting wires **3** and the sensors **20**, **21** is also further reduced. A sensor unit **2** fitted with a sensor unit sleeve **28** is shown in FIG. **4a**. The sensor unit sleeve **28** partially covers the electrical components and the printed circuit board **22**. When in use, as shown in FIG. **4b** along the cross-sectional

line B-B, the sensor unit **2** with its sensor unit sleeve **28** is laid or pressed onto the skin **H** of a user, and the measurement of heat flows and temperatures can thus take place, and the current core body temperature can be determined using algorithms of known art. Here the sensor unit sleeve **28** also extends onto the side of the printed circuit board **22** facing away from the skin, and the sensor unit sleeve **28** is surrounded by an adhesive pad **4**.

[0054] After the manufacture of the sensor unit **2** with the sensor unit sleeve **28** attached, the printed circuit board **22** together with the protruding sensor unit sleeve **28** can be attached in a cavity **12*** of the adhesive pad **4**, which is of known art from medical technology, and serves, for example, for the attachment of electrodes to the skin. The connecting wires **3** can be connected to the electronics of a medical device, either before or after the attachment of the sensor unit **2** in the adhesive pad **4**. The adhesive pad **4** is manufactured from the same materials as the thermal insulator **23** and has an adhesive layer that is compatible with the skin, e.g. as is of known art from the company 3M.

[0055] The thermal conductivity λ of the material of the thermal adhesive pad **4** should be of the order of that for air ($\lambda_{air}=0.024$ W/m/K), i.e. between 0.01 W/m/K and 0.1 W/m/K.

[0056] In order to introduce the sensor unit **2** as easily as possible into a housing **1** of a portable computer system **0**, the following methods are used.

[0057] Preferred Manufacturing and Integration Method

[0058] FIG. 6 show a method for the integration of a sensor unit **2** into a housing **1** of a portable computer system **0**. A sensor unit **2** is used to cover a through hole **12** in the housing **1** in such a way that the edges of the printed circuit board **22** close off the through hole **12**. Here the electronic components such as the heat flow sensor **20** and the temperature sensor **21**, are positioned at the height of the through hole **12**, or protrude into the through hole **12**. The printed circuit board **22** can be bonded to the walls of the housing **1** by means of adhesive. As a result of covering the through hole **12** with the printed circuit board **22**, in a further step the through hole **12** can be filled, for example with a silicone mass, so as to form the sensor unit sleeve **28**. Here, the filling in FIG. 6b is executed in such a way that a part of the sensor unit sleeve **28** protrudes from the through hole **12** in the direction of the skin contact side **10**. The positioning of the printed circuit board **22** is carried out as indicated by the arrow. The sensor unit **2** is executed as described above, but is only fitted with the sensor unit sleeve **28** after the printed circuit board **22** has been fixed in place. The through hole **12** is filled from the direction of the interior **11** of the housing **1**.

[0059] The connecting wires **3** from the printed circuit board **22** to the electronics (not shown) can either be connected before the casting or filling process, or only after the cavity **12** has been filled.

[0060] In order to obtain accelerated heat conduction, and to maintain an equilibrium between the environment and the body, a metal rod **M**, which crosses the interior **11** of the housing **1** and is in contact with the exterior of the housing **1**, is attached onto the side of the printed circuit board **22** facing away from the body, pointing in the direction of the interior **11** and at the height of the heat flow sensor **20**. Depending on the embodiment, this metal rod **M** can also be thermally insulated on its side walls.

[0061] It is also possible to use another manufacturing method, which is described in FIGS. 7a to 7c. After the manufacture of the sensor unit **2**, it is placed in a casting mould **5**, whereby the connecting wires **3** protrude from the casting mould **5**. The walls of the casting mould **5** can be made either from metal or a plastic material.

[0062] In the next step, the casting mould **5** is filled with a material that later forms the sensor unit sleeve **28**. The sensor unit **2** is enclosed by the material on all sides, such that the printed circuit board **22** and all components are enclosed by the sensor unit sleeve **28**. After curing, the enclosed sensor unit **2** can be placed in a cavity **12, 13** in the housing **1** of a portable computer system **0**, and pressed into it in a detachably held manner. The thermally sufficiently conductive material of the sensor unit sleeve **28** makes close contact with the walls of the cavity **12, 13**, which prevents it from slipping out unintentionally. The sensor unit **2** embedded in the sensor unit sleeve **28** forms a plug, which remains in the cavity **12, 13**.

[0063] To improve the retention, a suitable adhesive can be used, which is distributed over the walls of the cavity **12, 13** before the sensor unit **2** encased in the sensor unit sleeve **28** is pressed in. Correspondingly, a non-detachable connection can also be achieved.

[0064] The casting mould **5** used here can optionally be used as a lost mould, can remain connected to the sensor unit **2**, or can be removed before the sensor unit **2** is mounted in the cavity **12** in the housing **1**.

[0065] In practice, when the sensor unit **2** is placed on the skin **H**, measured values from the at least one heat flow sensor **20, 20'** and the at least one temperature sensor **21, 21'** are recorded, from which the core body temperature can be determined, using a variety of algorithms. Calibration measurements are necessary for the most accurate determinations possible, and the types and thicknesses of the materials used must be known. Multiple possible algorithms are of known art, which lead to useful results in the determination of the core body temperature.

[0066] The sensor unit **2** is preferably inserted into the sensor unit sleeve **28** in such a way that the sensor unit sleeve **28** is partially arranged so as to protrude from the housing **1**, away from the walls of the housing **1**. The thermal coupling of the sensor unit **2**, or more particularly, the sensors **20, 21**, is then optimised accordingly.

[0067] The sensor unit sleeve **28** could be a sleeve or a cylinder made from PVC, for example, which is filled with the thermally conductive material. This cylinder could also be made of an insulating material (foam), so as to better define the thermal path.

[0068] In one variant, the sensor unit **2** can have multiple printed circuit boards **22**, separated from one another, on which temperature sensors **21, 21'** and heat flow sensors **20, 20'** and/or other electronic components can be arranged, separated from one another. All the printed circuit boards **22** should then be at least partially surrounded by at least one sensor unit sleeve **28**. If an infrared sensor is used as the temperature sensor **21, 21'**, it must not be surrounded by the sensor unit sleeve **28**.

LIST OF REFERENCE SYMBOLS

- [0069] **0** Portable computer system
- [0070] **1** Housing
- [0071] **10** Skin contact side

- [0072] 11 Interior
- [0073] 12 Cavity/through hole
- [0074] 13 Cavity/blind hole
- [0075] 2 Sensor unit
 - [0076] 20, 20' Heat flow sensor (at least 1)
 - [0077] 21, 21' Temperature sensor (at least 1)
 - [0078] 22 Printed circuit board, PCB
 - [0079] 23 Thermal insulator
 - [0080] 24 Thermal capacitance
 - [0081] 25 Analogue-to-digital converter
 - [0082] 26 Microcontroller
 - [0083] 27 Read-out/storage unit
 - [0084] 28 Sensor unit sleeve
 - [0085] 29 Integrated switching circuit, packaged
 - [0086] 30 Metal plate
 - [0087] A Cavity
- [0088] 3 Connecting cable (to the electronics)
- [0089] 4 Adhesive pad (to be attached to the skin)
- [0090] 5 Casting mould

1. A sensor unit for determining the core body temperature by means of measured values, which can be determined outside the body on a surface, comprising at least one heat flow sensor and at least one temperature sensor,

wherein the sensor unit comprises at least one printed circuit board and at least one monolithic heat flow sensor, in the form of a sandwich-like structure comprising multiple layers of different materials, and at least one temperature sensor,

which are soldered, spaced apart from one another onto the at least one printed circuit board, wherein the sensors can be connected to an analogue-to-digital converter and a microcontroller by way of wires or strip conductors,

the electronic components can be connected by means of connecting wires or strip conductors to the electronics of a portable computer system, and the at least one printed circuit board, with electronic components arranged thereon, are at least partially surrounded by a sensor unit sleeve.

2. The sensor unit in accordance with claim 1, wherein the sensor unit comprises two printed circuit boards, and the at least one heat flow sensor and the at least one temperature sensor are arranged on different printed circuit boards that are spatially separated.

3. The sensor unit in accordance with claim 2, wherein the at least one printed circuit board with the temperature sensor remains at least partially free of the sensor unit sleeve.

4. The sensor unit in accordance with claim 1, wherein the at least one monolithic heat flow sensor and the at least one temperature sensor are soldered layered on top of one another, onto the same side of the at least one printed circuit Board.

5. The sensor unit in accordance with claim 1, wherein the sensor unit, and/or the at least one primed circuit board, is completely encased by the sensor unit sleeve.

6. The sensor unit in accordance with claim 1, wherein an analogue-to-digital converter is arranged directly attached onto the at least one printed circuit board.

7. The sensor unit in accordance with claim 6, wherein in addition a microcontroller and a read-out/storage unit are arranged attached onto the at least one printed circuit board.

8. The sensor unit in accordance with claim 1, wherein two heat flow sensors are soldered onto the same side of the at least one printed circuit board spaced apart from one

another in the longitudinal direction, and a thermal insulator is arranged on the side of the printed circuit board that is free of heat flow sensors, at the height of the first heat flow sensor in the longitudinal direction, such that a first heat flow can be measured through the thermal insulator and the first heat flow sensor, and a second heat flow can be measured through the second heat flow sensor.

9. The sensor unit in accordance with claim 1, wherein two heat flow sensors are soldered onto the same side of the at least one printed circuit board, spaced apart from one another in the longitudinal direction, and a thermal capacitance arranged on the side of the at least one printed circuit board that is free of heat flow sensors, at the height of the first heat flow sensor in the longitudinal direction, such that a first heat flow can be measured through the thermal capacitance and the first heat flow sensor, and a second heat flow can be measured through the second heat flow sensor.

10. The sensor unit in accordance with claim 1, wherein on the side of the at least one printed circuit board that is free of heat flow sensors a metal plate is arranged so as to be extensively in contact with a thermal insulator, and/or a thermal capacitance, and/or a block made from a thermally conductive material, and/or a part of the sensor unit sleeve.

11. The sensor unit in accordance with claim 1, wherein on one side of the at least one printed circuit board, a heat flow sensor, a first temperature sensor, and a thermal insulator are spaced apart from one another in the longitudinal direction, and on the opposite side of the at least one printed circuit board that is free of heat flow sensors a second temperature sensor is arranged at the height of the thermal insulator along the longitudinal direction, such that a first temperature can be measured at the location of the first temperature sensor, and a second temperature can be measured at the location of the second temperature sensor after passage of the heat flow through the thermal insulator.

12. The sensor unit in accordance with claim 1, wherein the at least one monolithic heat flow sensor, the at least one temperature sensor, the analogue-to-digital converter, the microcontroller, the thermal insulator, and/or the thermal capacitance, packaged in an integrated circuit, are attached onto one side of the at least one printed circuit board.

13. The sensor unit in accordance with claim 1, wherein the sensor unit sleeve housing is mechanically flexible, and the thermal conductivity should lie between 0.3 and 10 W/mK, preferably between 0.8 and 3 W/mK, that is to say, it is particularly preferably manufactured from a thermally conductive silicone.

14. The sensor unit in accordance with claim 8, wherein the material of the thermal insulator has a thermal conductivity λ of between 0.01 W/m*K) and 0.1 W/(m*K), and is a polymer, in particular ethylene-propylene.-diene rubber (EPDM), or polypropylene.

15. The sensor unit in accordance with claim 1, wherein the cross-sectional area of the at least one printed circuit board is at least partially circular, and the strip conductors are guided at least partially along circular lines to the centre of the at least one printed circuit board, wherein the soldering surfaces of the at least one heat flow sensor and of the at least one temperature sensor are located in the centre of the at least one printed circuit board.

16. The sensor unit in accordance with claim 15, wherein the centre of the at least one printed circuit board is surrounded by cavities, wherein the cavities are executed as kidney shapes.

17. The sensor unit in accordance with claim 1, wherein the sensor unit sleeve, or a metal rod (M) arranged on the printed circuit board, protrudes from the side of the printed circuit board opposite the skin contact side, and particularly preferably extends up to the wall of the housing.

18. The sensor unit in accordance with claim 1, wherein a thermal insulator and/or a thermal capacitance, is arranged extending within the printed circuit board and is formed by an insulating layer inclusion, preferably an air pocket, and/or by thermovias.

19. A portable computer system, with a sensor unit in accordance with claim 1.

20. A method for the integration of a sensor unit, comprising at least one measuring sensor and electronic components on a printed circuit board, into a housing of a portable computer system, the method comprising:

provision of a housing with a cavity in the form of a through hole,

provision of the sensor unit, comprising a printed circuit board from which at least one heat flow sensor protrudes, wherein the sensors are connected to an analogue-to-digital converter, a microcontroller, and a read-out/storage unit,

positioning of the printed circuit board above the through hole in the housing, and attachment of the printed circuit board onto the walls of the housing,

filling of the through hole, closed on one side, with a flowable material, which forms a sensor unit sleeve, and subsequently

connection of the printed circuit board by means of connecting wires to the electronics of the portable computer system.

21. The method for the integration of a sensor unit in accordance with claim 20, wherein after the filling of the through hole, the sensor unit sleeve protrudes at least partially from the through hole in the direction of a skin contact side.

22. The manufacture of a sensor unit, comprising at least one measuring sensor and electronic components on a printed circuit board, and the integration of the sensor unit into a housing of a portable computer system, or into an adhesive pad, for attachment onto the skin (H), characterised by the steps:

provision of a housing with a cavity, or an adhesive pad with a cavity,

provision of the sensor unit,

insertion of the sensor unit into a casting mould, wherein connecting wires protrude from the casting mould,

casting of a mechanically flexible curing material, preferably a thermally conductive silicone, into the casting mould so as to form a sensor unit sleeve,

curing of the sensor unit sleeve,

insertion of the sensor unit enclosed by the sensor unit sleeve into the cavity in the housing of the portable computer system, or the cavity in the adhesive pad, and subsequent connection of the connecting wires to the electronics of the portable computer system.

23. The method in accordance with claim 22, wherein the casting, mould remains as a lost mould on the material of the sensor unit sleeve.

24. The method in accordance with claim 22, wherein the casting mould is removed from the sensor unit sleeve after the curing of the latter.

25. The method in accordance with claim 24, wherein the cavity is designed as a through hole.

26. The method in accordance with claim 24, wherein the cavity is designed as a blind hole.

27. The method in accordance with claim 22, wherein the inner walls of the cavities are coated with an adhesive, before the sensor unit sleeve, or the sensor unit sleeve encased by the casting mould, is plugged into the cavity.

* * * * *

专利名称(译)	用于便携式计算机系统的传感器单元以及传感器单元的集成		
公开(公告)号	US20200085310A1	公开(公告)日	2020-03-19
申请号	US16/470877	申请日	2017-12-15
申请(专利权)人(译)	GREENTEG AG		
当前申请(专利权)人(译)	GREENTEG AG		
[标]发明人	ZAHNER MICHELE HELBLING THOMAS DURRER LUKAS SCHWYTER ETIENNE		
发明人	ZAHNER, MICHELE HELBLING, THOMAS DURRER, LUKAS SCHWYTER, ETIENNE		
IPC分类号	A61B5/01 A61B5/00 G01K13/00 G01K1/16		
CPC分类号	A61B5/0008 G01K13/002 A61B5/01 A61B2562/0271 G01K1/165 A61B5/681 G01K1/16		
优先权	2016001695 2016-12-21 CH		
外部链接	Espacenet USPTO		

摘要(译)

本发明涉及一种用于通过测量值确定芯体温度的传感器单元 (2)，该测量值可以在体外在表面上确定，包括至少一个热流传感器 (20、20'；) 和至少一个温度传感器 (21、21'；)，可以轻松紧凑地生产和安装，并且可以优化确定芯体温度。这是通过传感器单元 (2) 包括至少一个整体式热流传感器 (20、20'；) 构成的，该结构为多层结构，由多层不同的材料组成，并具有至少一个温度传感器 (21、21'；) 沿电路板 (22) 的纵向方向以相同的高度焊接到电路板 (22) 上或以相同的高度焊接到电路板 (22) 上，其中传感器 (20、21) 通过导线或带状导体连接到模数转换器 (25) 和微控制器 (26)，电子组件 (20、21、25、26) 可以连接到便携式计算机系统的电子设备 通过连接线 (3)，其上布置有电子部件 (20、21、25、26) 的传感器单元 (2) 或电路板 (22) 至少部分地被传感器单元套筒 (28) 包围 沿电路板 (22) 的横向方向。

