



US 20150351697A1

(19) **United States**
(12) **Patent Application Publication**
Weber et al.

(10) **Pub. No.: US 2015/0351697 A1**
(43) **Pub. Date: Dec. 10, 2015**

(54) **VARIABLE INDICATION ESTIMATOR**

Publication Classification

(71) Applicant: **MASIMO CORPORATION**, Irvine, CA (US)

(51) **Int. Cl.**
A61B 5/00 (2006.01)
A61B 5/021 (2006.01)
A61B 5/1455 (2006.01)

(72) Inventors: **Walter M. Weber**, Laguna Hills, CA (US); **Ammar Al-Ali**, Tustin, CA (US); **Lorenzo Cazzoli**, Barcelona (ES)

(52) **U.S. Cl.**
CPC *A61B 5/7271* (2013.01); *A61B 5/14551* (2013.01); *A61B 5/021* (2013.01); *A61B 5/6826* (2013.01); *A61B 5/6829* (2013.01)

(21) Appl. No.: **14/830,211**

(22) Filed: **Aug. 19, 2015**

Related U.S. Application Data

(57) **ABSTRACT**

(63) Continuation of application No. 13/942,562, filed on Jul. 15, 2013, now Pat. No. 9,138,192, which is a continuation of application No. 13/601,930, filed on Aug. 31, 2012, now Pat. No. 8,489,364, which is a continuation of application No. 13/007,109, filed on Jan. 14, 2011, now Pat. No. 8,260,577, which is a continuation of application No. 12/362,463, filed on Jan. 29, 2009, now Pat. No. 7,873,497, which is a continuation of application No. 11/375,662, filed on Mar. 14, 2006, now Pat. No. 7,499,835, which is a continuation of application No. 10/213,270, filed on Aug. 5, 2002, now Pat. No. 6,999,904, which is a continuation-in-part of application No. 09/586,845, filed on Jun. 5, 2000, now Pat. No. 6,430,525.

A variable indication estimator which determines an output value representative of a set of input data. For example, the estimator can reduce input data to estimates of a desired signal, select a time, and determine an output value from the estimates and the time. In one embodiment, the time is selected using one or more adjustable signal confidence parameters determine where along the estimates the output value will be computed. By varying the parameters, the characteristics of the output value are variable. For example, when input signal confidence is low, the parameters are adjusted so that the output value is a smoothed representation of the input signal. When input signal confidence is high, the parameters are adjusted so that the output value has a faster and more accurate response to the input signal.

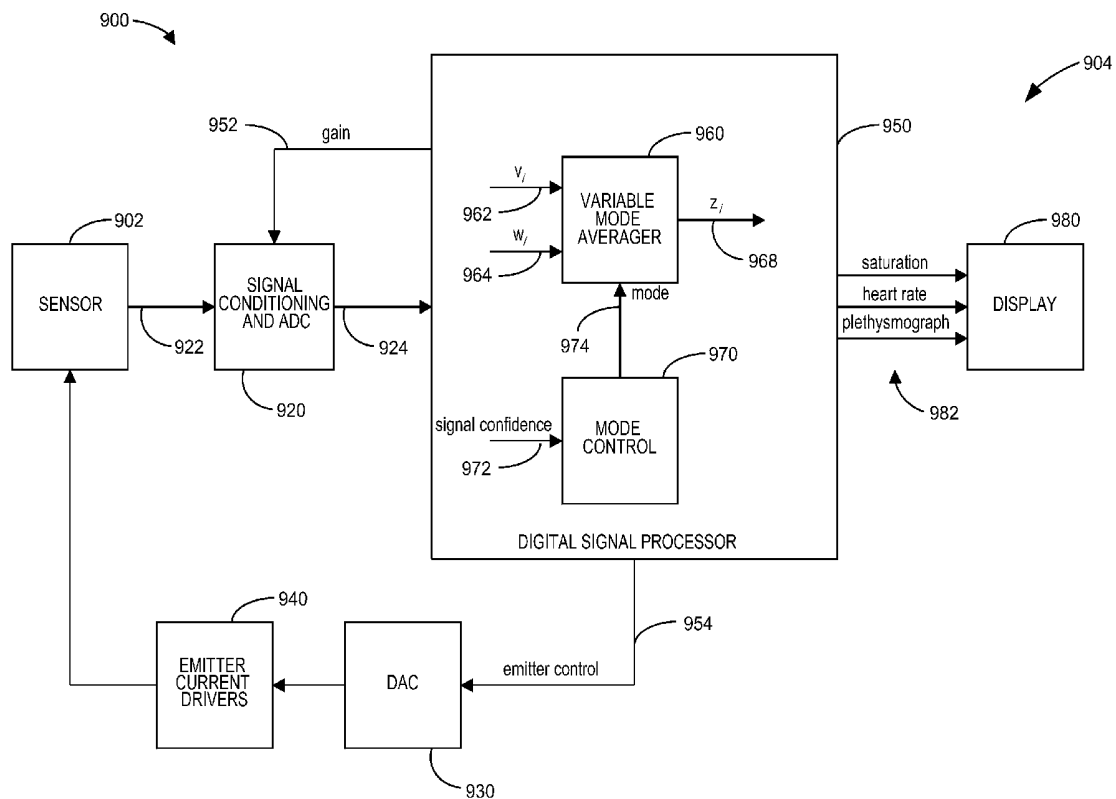

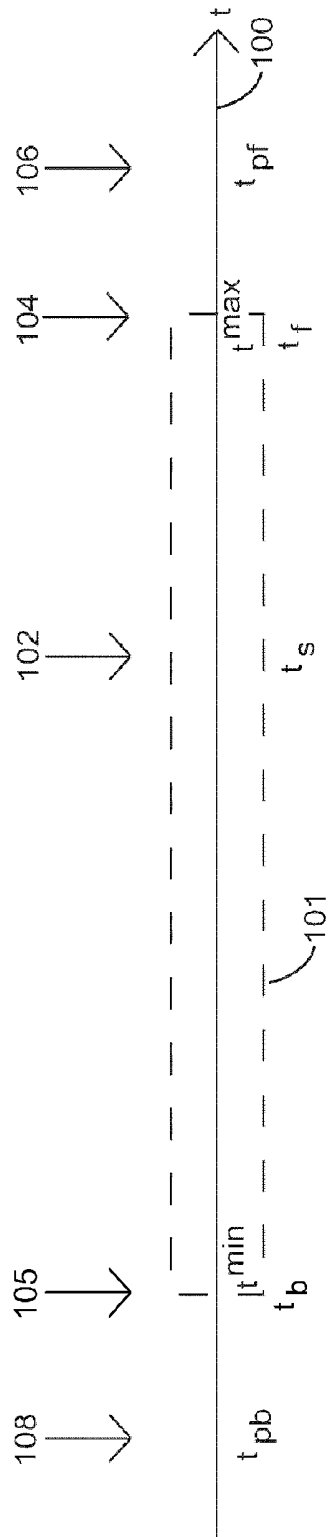

FIG. 1

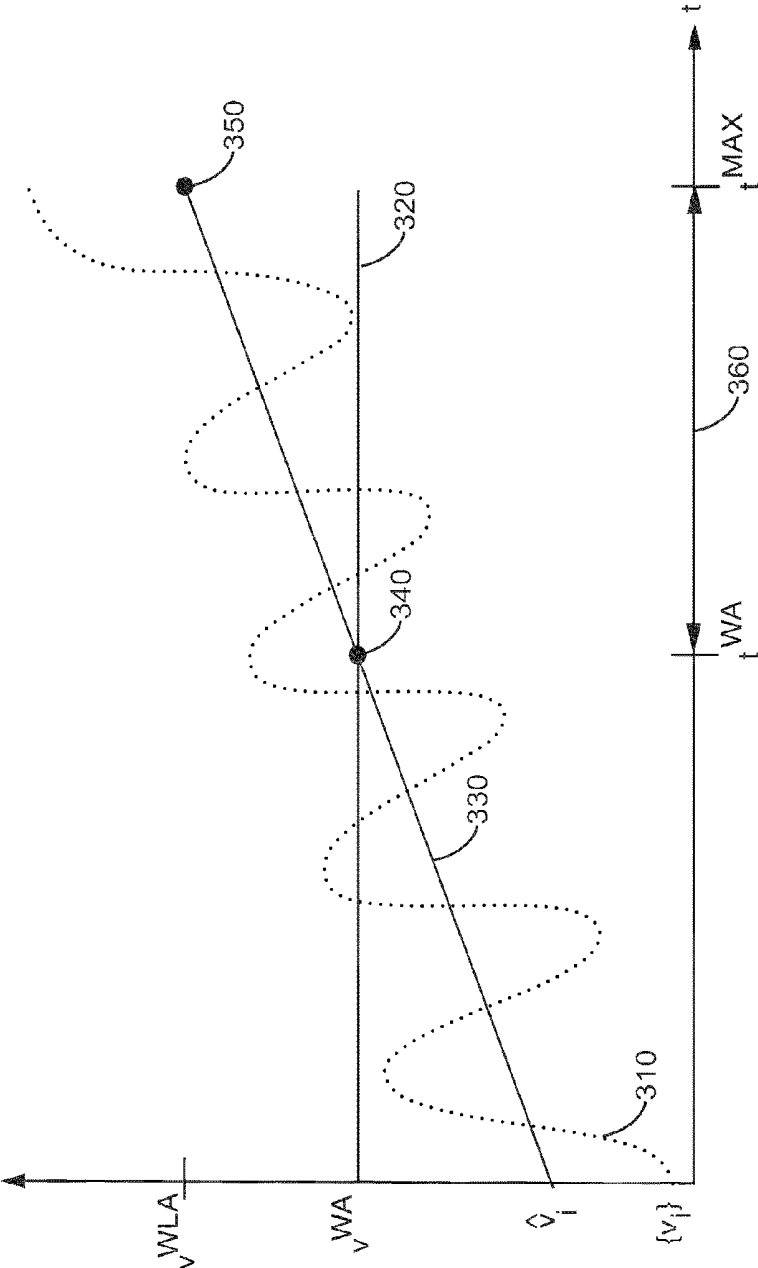

FIG. 3

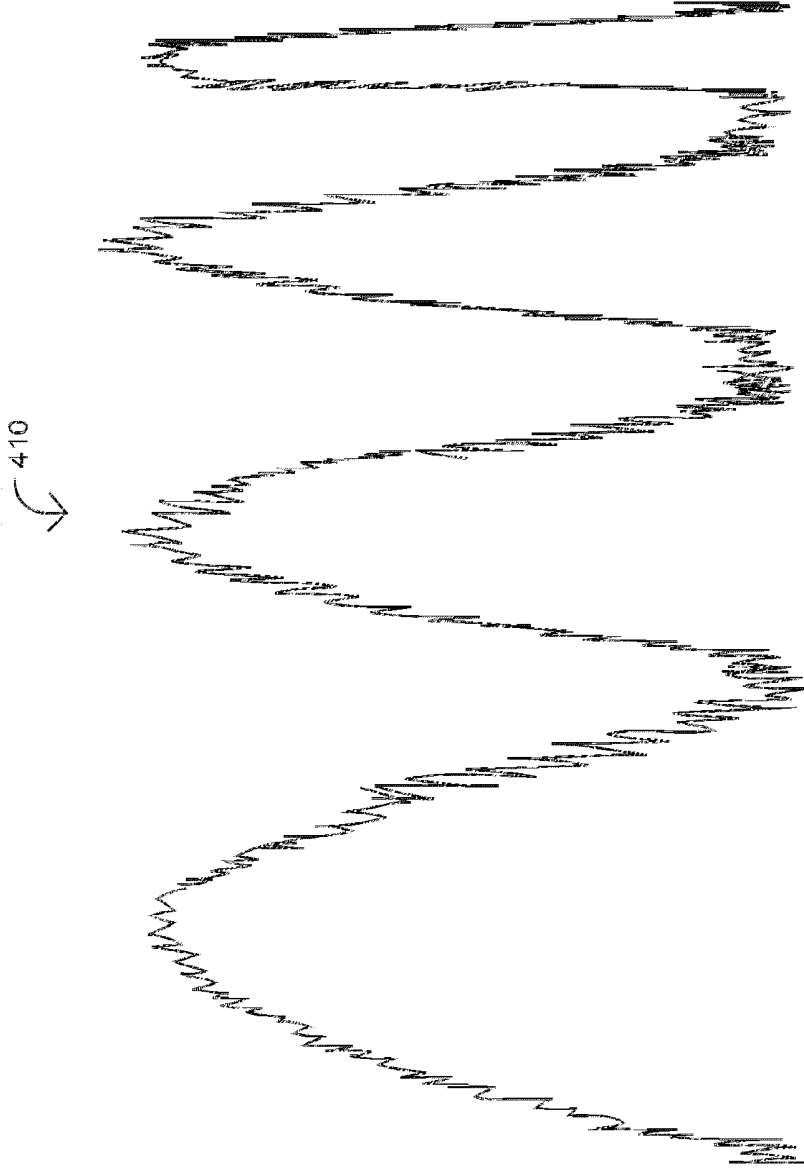

FIG. 4

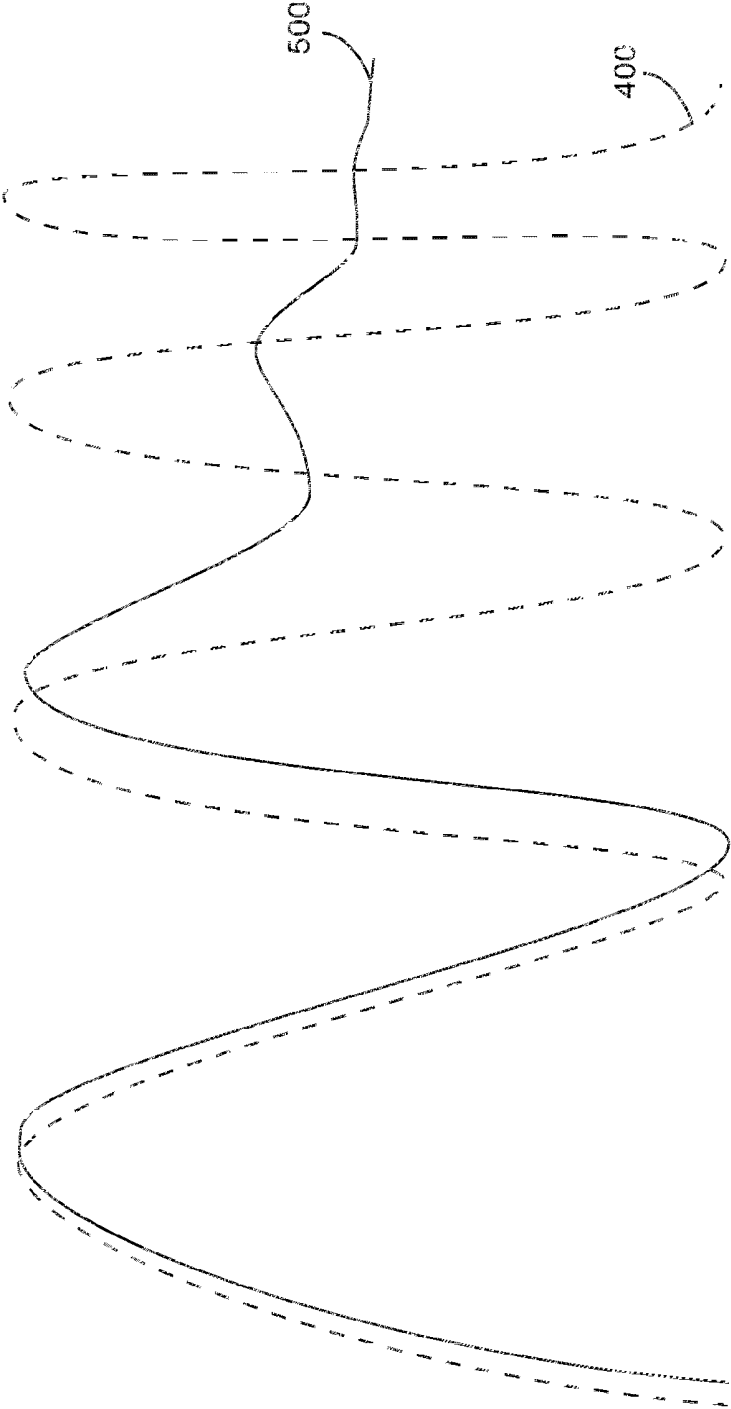

FIG. 5

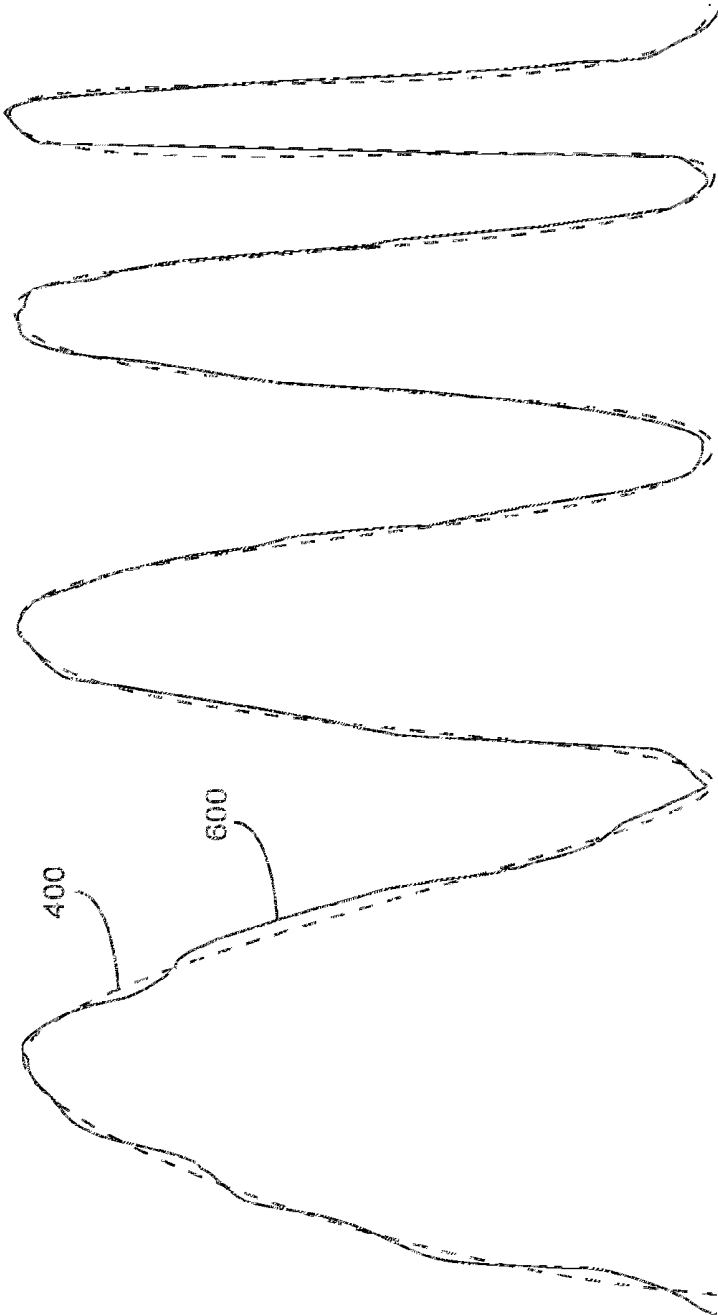

FIG. 6

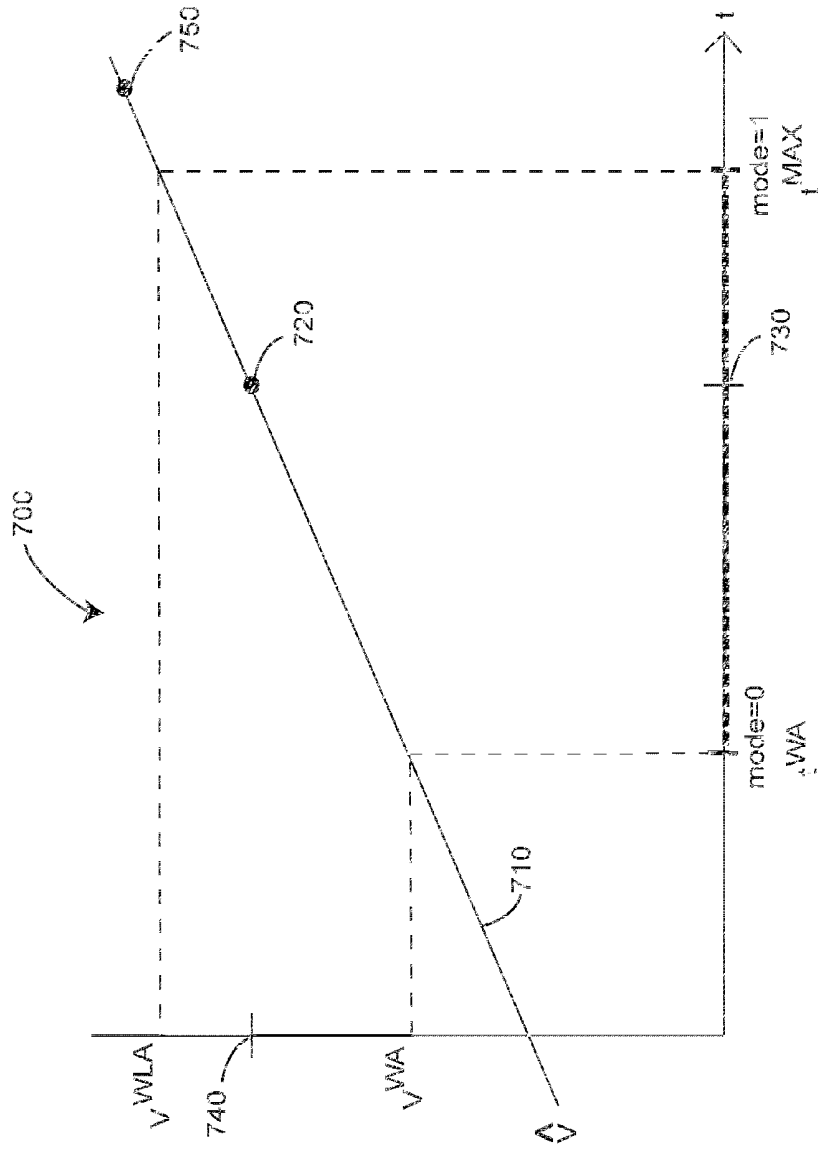

FIG. 7

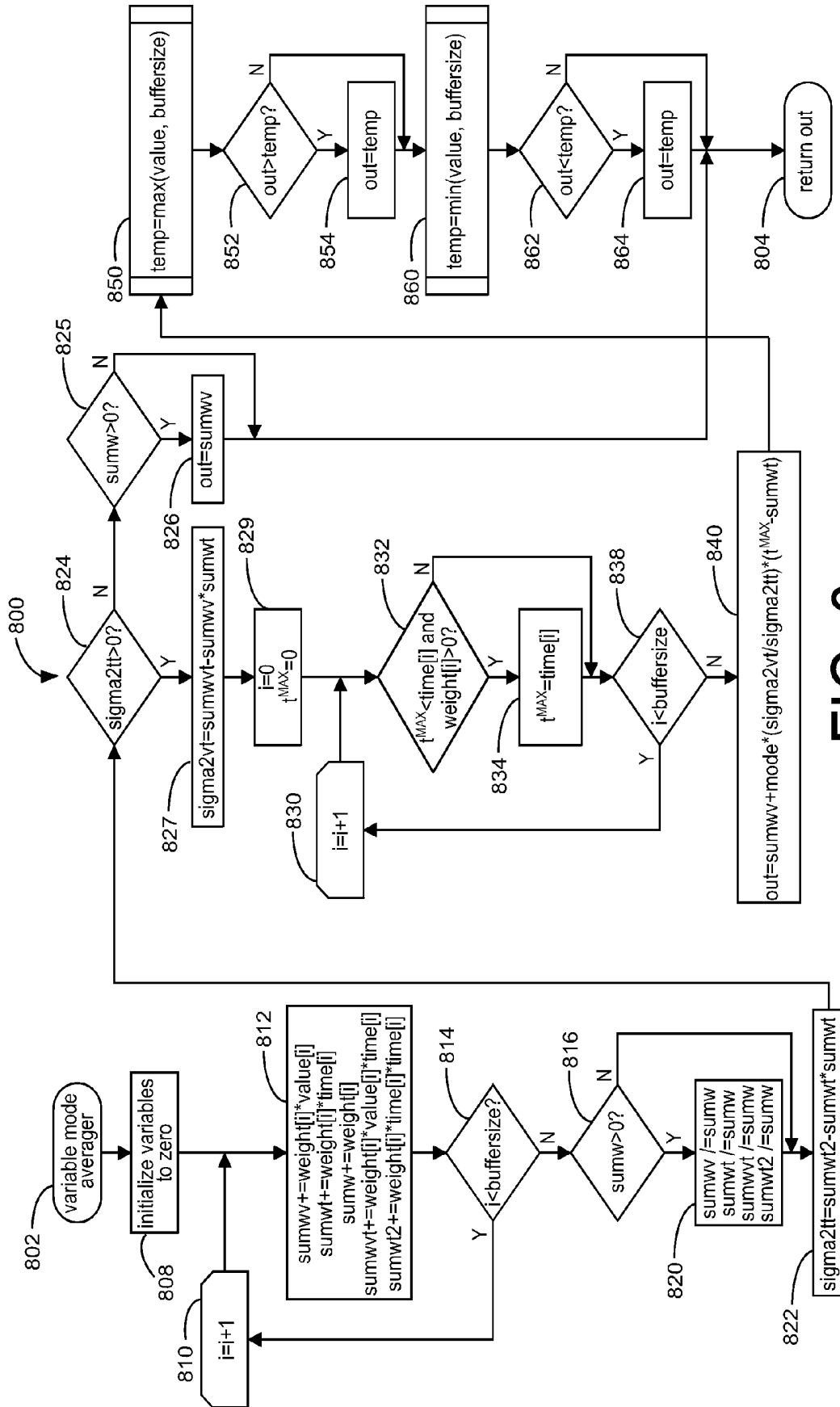

FIG. 8

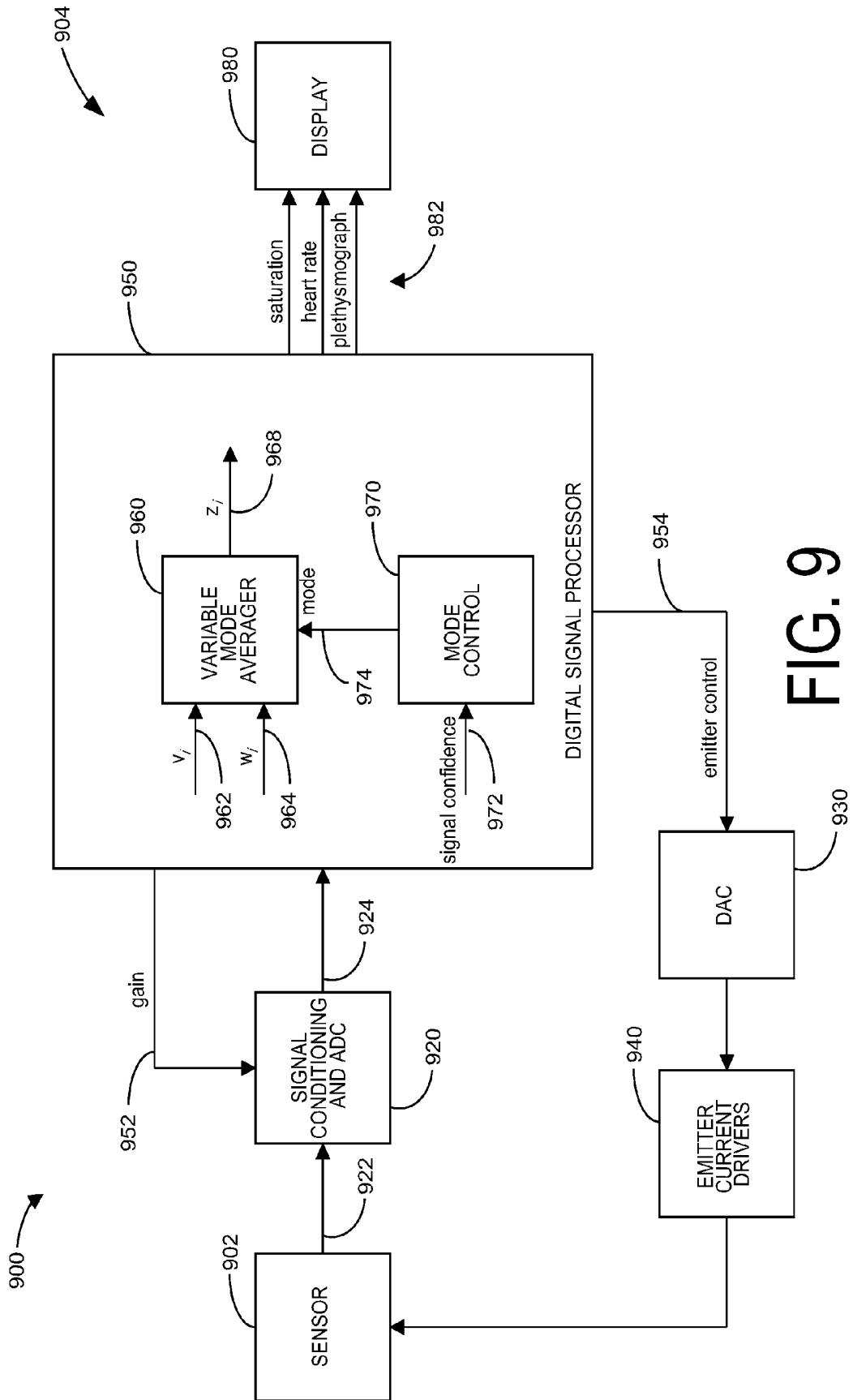

FIG. 9

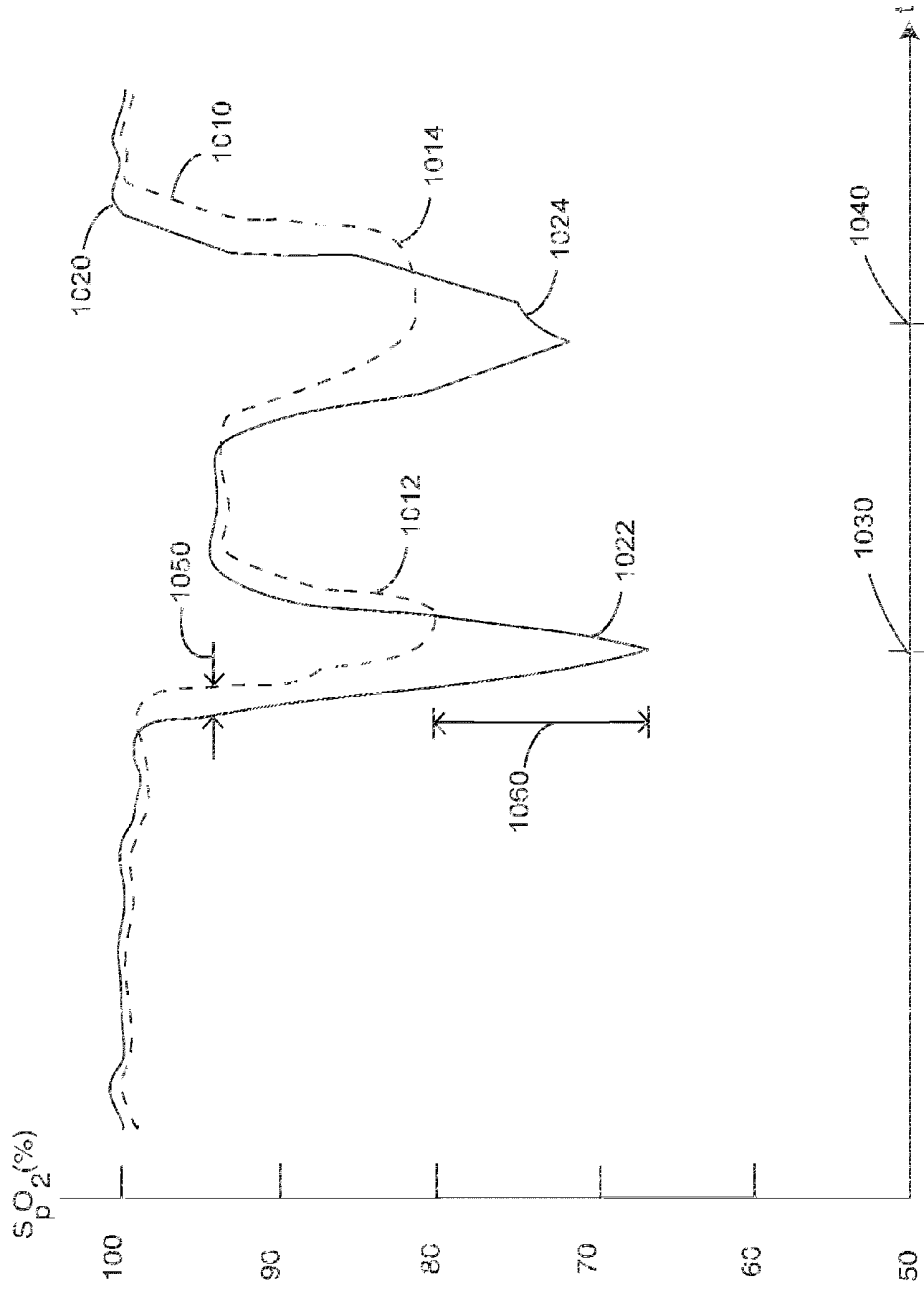

FIG. 10

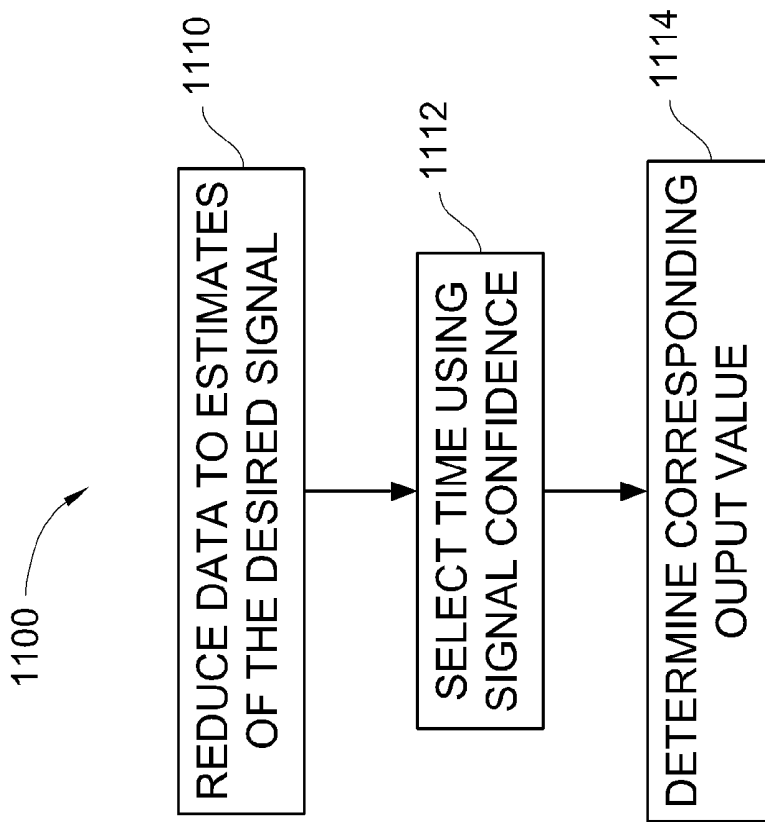

FIG. 11

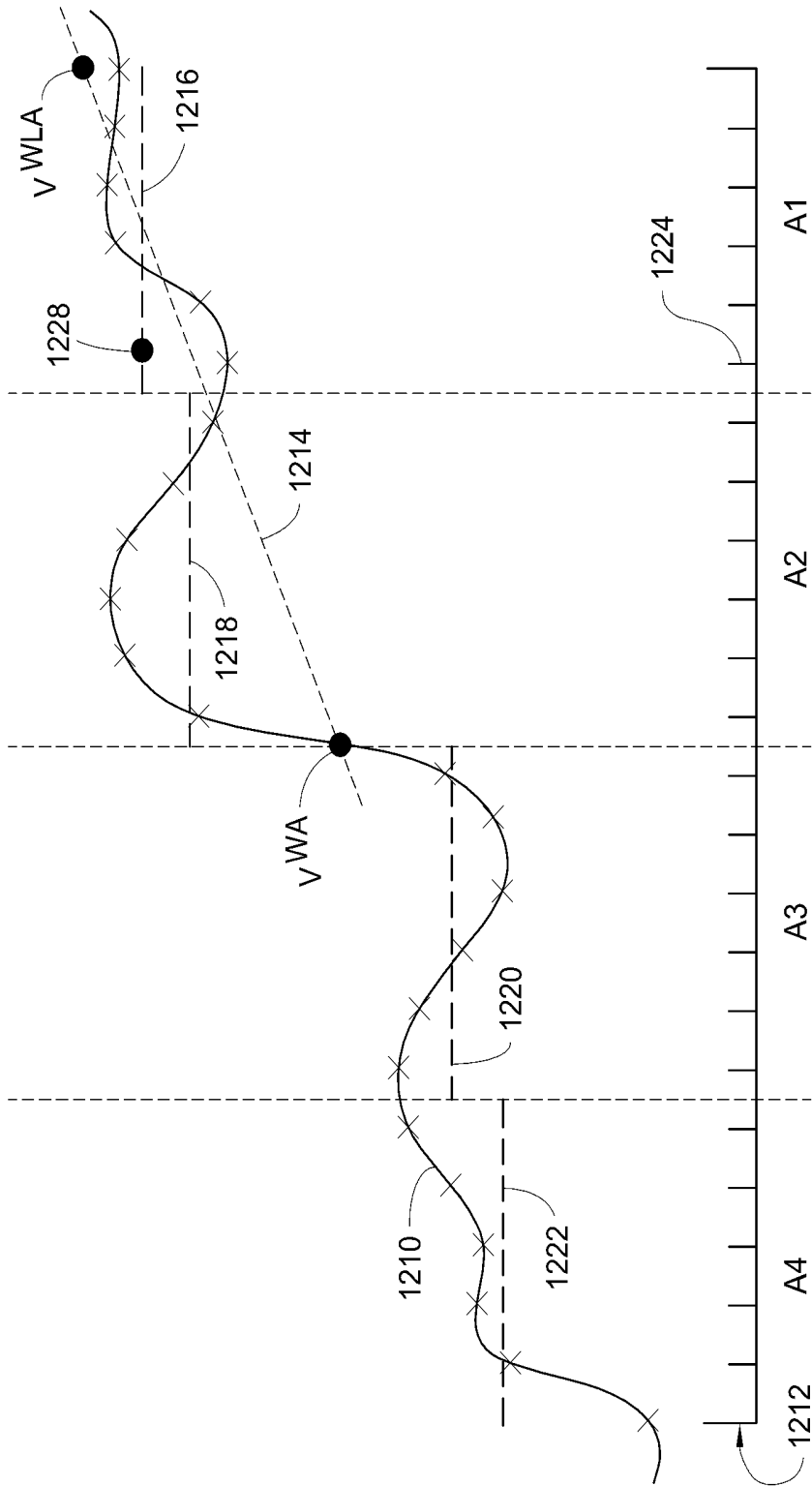

FIG. 12

VARIABLE INDICATION ESTIMATOR

INCORPORATION BY REFERENCE TO ANY PRIORITY APPLICATIONS

[0001] Any and all applications, if any, for which a foreign or domestic priority claim can be identified in the Application Data Sheet of the present application is hereby incorporated by reference under 37 CFR 1.57.

FIELD OF THE INVENTION

[0002] The present invention is directed to the field of signal processing, and, more particularly, is directed to systems and methods for determining a representative estimate output value for a window of input data.

BACKGROUND OF THE INVENTION

[0003] Digital signal processing techniques are frequently employed to enhance a desired signal in a wide variety of applications, such as health care, communications and avionics, to name a few. Signal enhancement includes smoothing, filtering and prediction. These processing techniques each operate on a block of input signal values, such as, for example, a window of input signal values, in order to estimate the signal at a specific point in time. FIG. 1 illustrates that smoothing, filtering and prediction can be distinguished by the time at which an output value is generated relative to input values. Shown in FIG. 1 is a time axis 100 and a block 101 of input signal values depicted in this example as occurring within a time window between points t^{min} and t^{max} . Specifically, the block 101 includes a set of discrete input values $\{v_i; i=1, 2, \dots, n\}$ occurring at a corresponding set of time points $\{t_i; i=1, 2, \dots, n\}$. A smoother operates on the block 101 of input values to estimate the signal at a time point, t_s 102 between t^{min} and t^{max} . That is, a smoother generates an output value based upon input values occurring before and after the output value. A filter operates on the block 101 of input values to estimate the signal at a time t_f 104, corresponding to the most recently occurring input value in the block 101. That is, a filter generates a forward filtered output value at the time t_f based upon input values occurring at, and immediately before, the output value. A filter also operates on the block 101 to estimate the signal at a time t_b 105 at the beginning of the block 101 to generate a backward filtered value. A forward predictor operates on the block of input values 101 to estimate the signal at time t_{pf} 106, which is beyond the most recently occurring value in the block 101. That is, a forward predictor generates a forward predicted output value based upon input values occurring prior to the output value. A backward predictor operates on the block 101 of input values to estimate the signal at time t_{pb} 108, which is before the earliest occurring value in the block 101. That is, a backward predictor generates a backward predicted output value based upon input values occurring after the output value.

SUMMARY OF THE INVENTION

[0004] A common smoothing technique uses an average to fit a constant, v^A , to a set of data values, $\{v_i; i=1, 2, \dots, n\}$:

$$v^A = \frac{1}{n} \cdot \sum_{i=1}^n v_i \quad (1)$$

[0005] A generalized form of equation (1) is the weighted average

$$v^{WA} = \frac{\sum_{i=1}^n w_i \cdot v_i}{\sum_{i=1}^n w_i} \quad (2)$$

[0006] Here, each value, v_i , is scaled by a weight, w_i , before averaging. This allows data values to be emphasized and de-emphasized relative to each other. If the data relates to an input signal, for example, values occurring during periods of low signal confidence can be given a lower weight and values occurring during periods of high signal confidence can be given a higher weight.

[0007] FIG. 2A illustrates the output of a constant mode averager, which utilizes the weighted average of equation (2) to process a discrete input signal, $\{v_i; i \text{ an integer}\}$ 110. The input signal 110 may be, for example, a desired signal corrupted by noise or a signal having superfluous features. The constant mode averager suppresses the noise and unwanted features, as described with respect to FIG. 5, below. A first time-window 132 defines a first set, $\{v_i; i=1, 2, \dots, n\}$, of signal values, which are averaged together to produce a first output value, z_1 122. A second time-window 134, shifted from the previous window 132, defines a second set $\{v_i; i=2, 3, \dots, n+1\}$ of signal values, which are also averaged together to produce a second output value z_2 124. In this manner, a discrete output signal, $\{z_j; j \text{ an integer}\}$ 120 is generated from a moving weighted average of a discrete input signal $\{v_i; i \text{ an integer}\}$ 110, where:

$$z_j = \frac{\sum_{i=j}^{n+j-1} w_i v_i}{\sum_{i=j}^{n+j-1} w_i} \quad (3)$$

[0008] A common filtering technique computes a linear fit to a set of data values, $\{v_i; i=1, 2, \dots, n\}$:

$$\hat{v}_i = \alpha \cdot t_i + \beta \quad (4)$$

[0009] where α and β are constants and t_i is the time of occurrence of the i^{th} value. FIG. 2B illustrates the output of a linear mode averager, which uses the linear fit of equation (4) to process a discrete input signal, $\{v_i; i \text{ an integer}\}$ 110. The input signal 110 may be, for example, a desired signal with important features corrupted by noise. The linear mode averager reduces the noise but tracks the important features, as described with respect to FIG. 6 below. A first time-window 132 defines a first set, $\{v_i; i=1, 2, \dots, n\}$, of signal values. A linear fit to these n values is a first line 240, and the value along this line at $\max\{t_1, t_2, \dots, t_n\}$ is equal to a first output

value, z_1 222. A second time-window 134 shifted from the previous window 132 defines a second set, $\{v_i; i=2, 3, \dots, n+1\}$, of signal values. A linear fit to these n values is a second line 250, and the value along this line at $\max\{t_2, t_3, \dots, t_{n+1}\}$ is equal to a second output value, z_2 224. In this manner, a discrete output signal, $\{z_j; j \text{ an integer}\}$ 220 is generated from a moving linear fit of a discrete input signal $\{v_i; i \text{ an integer}\}$, where:

$$z_j = \alpha_j \cdot t_{n+j-1}^{MAX} + \beta_j \quad (5a)$$

$$t_{n+j-1}^{MAX} = \max\{t_j, t_{j+1}, \dots, t_{n+j-1}\} \quad (5b)$$

[0010] In general, the time windows shown in FIGS. 2A-2B may be shifted from each other by more than one input value, and values within each time window may be skipped, i.e., not included in the average. Further, the t_i 's may not be in increasing or decreasing order or uniformly distributed, and successive time windows may be of different sizes. Also, although the discussion herein refers to signal values as the dependent variable and to time as the independent variable to facilitate disclosure of the present invention, the concepts involved are equally applicable where the variables are other than signal values and time. For example, an independent variable could be a spatial dimension and a dependent variable could be an image value.

[0011] The linear mode averager described with respect to FIG. 2B can utilize a "best" linear fit to the input signal, calculated by minimizing the mean-squared error between the linear fit and the input signal. A weighted mean-squared error can be described utilizing equation (4) as:

$$\varepsilon(\alpha, \beta) = \sum_{i=1}^n w_i (v_i - \hat{v}_i)^2 / \sum_{i=1}^n w_i \quad (6a)$$

$$\varepsilon(\alpha, \beta) = \sum_{i=1}^n w_i [v_i - (\alpha \cdot t_i + \beta)]^2 / \sum_{i=1}^n w_i \quad (6b)$$

[0012] Conventionally, the least-mean-squared (LMS) error is calculated by setting the partial derivatives of equation (6b) with respect to α and β to zero:

$$\frac{\partial}{\partial \alpha} \varepsilon(\alpha, \beta) = 0 \quad (7a)$$

$$\frac{\partial}{\partial \beta} \varepsilon(\alpha, \beta) = 0 \quad (7b)$$

[0013] Substituting equation (6b) into equation (7b) and taking the derivative yields:

$$-2 \sum_{i=1}^n w_i [v_i - (\alpha \cdot t_i + \beta)] / \sum_{i=1}^n w_i = 0 \quad (8)$$

[0014] Solving equation (8) for β and substituting the expression of equation (2) yields:

$$\beta = \frac{\sum_{i=1}^n w_i \cdot v_i}{\sum_{i=1}^n w_i} - \alpha \frac{\sum_{i=1}^n w_i \cdot t_i}{\sum_{i=1}^n w_i} \quad (9a)$$

$$\beta = v^{WA} - \alpha \cdot t^{WA} \quad (9b)$$

[0015] where the weighted average time, t^{WA} , is defined as:

$$t^{WA} = \frac{\sum_{i=1}^n w_i \cdot t_i}{\sum_{i=1}^n w_i} \quad (10)$$

[0016] Substituting equation (9b) into equation (4) gives:

$$\hat{v}_i = \alpha(t_i - t^{WA}) + v^{WA} \quad (11)$$

[0017] Substituting equation (11) into equation (6a) and rearranging terms results in:

$$\varepsilon(\alpha, \beta) = \sum_{i=1}^n w_i [(v_i - v^{WA}) - \alpha \cdot (t_i - t^{WA})]^2 / \sum_{i=1}^n w_i \quad (12)$$

[0018] Changing variables in equation (12) gives:

$$\varepsilon(\alpha, \beta) = \sum_{i=1}^n w_i (v'_i - \alpha \cdot t'_i)^2 / \sum_{i=1}^n w_i \quad (13)$$

[0019] where:

$$v'_i = v_i - v^{WA} \quad (14a)$$

$$t'_i = t_i - t^{WA} \quad (14b)$$

[0020] Substituting equation (13) into equation (7a) and taking the derivative yields

$$-2 \sum_{i=1}^n w_i t'_i (v'_i - \alpha \cdot t'_i) / \sum_{i=1}^n w_i = 0 \quad (15)$$

[0021] Solving equation (15) for α gives:

$$\alpha = \frac{\sum_{i=1}^n w_i v'_i t'_i / \sum_{i=1}^n w_i}{\sum_{i=1}^n w_i t'^2_i / \sum_{i=1}^n w_i} \quad (16)$$

[0022] Substituting equations (14a, b) into equation (16) results in:

$$\alpha = \frac{\sum_{i=1}^n w_i (v_i - v^{WA})(t_i - t^{WA}) / \sum_{i=1}^n w_i}{\sum_{i=1}^n w_i (t_i - t^{WA})^2 / \sum_{i=1}^n w_i} \quad (17a)$$

$$\alpha = \frac{\sigma_v^2}{\sigma_t^2} \quad (17b)$$

[0023] where:

$$\sigma_v^2 = \sum_{i=1}^n w_i (v_i - v^{WA})(t_i - t^{WA}) / \sum_{i=1}^n w_i \quad (18a)$$

$$\sigma_t^2 = \sum_{i=1}^n w_i (t_i - t^{WA})^2 / \sum_{i=1}^n w_i \quad (18b)$$

[0024] Finally, substituting equation (17b) into equation (11) provides the equation for the least-mean-square (LMS) linear fit to $\{v_i, i=1, 2, \dots, n\}$:

$$\hat{v}_i = \frac{\sigma_v^2}{\sigma_t^2} (t_i - t^{WA}) + v^{WA} \quad (19)$$

[0025] FIG. 3 provides one comparison between the constant mode averager, described above with respect to FIG. 2A and equation (2), and the linear mode averager, described above with respect to FIG. 2B and equation (19). Shown in FIG. 3 are input signal values $\{v_i=1, 2, \dots, n\}$ 310. The constant mode averager calculates a constant 320 for these values 310, which is equal to v^{WA} , the weighted average of the input values v_i . Thus, the constant mode averager output 340 has a value V^{WA} . For comparison to the linear mode averager, the constant mode averager output can be conceptualized as an estimate of the input values 310 along a linear fit 350, evaluated at time t^{WA} . The linear mode averager may be thought of as calculating a LMS linear fit, \hat{v}_i 330 to the input signal values, v_i 310. The linear mode averager output 350 has a value, The linear mode averager output is an estimate of the input values 310 along the linear fit 330, described by equation (19), evaluated at an index i such that $t_i=t^{MAX}$.

$$v^{WA} = \frac{\sigma_v^2}{\sigma_t^2} (t^{MAX} - t^{WA}) + v^{WA} \quad (20)$$

[0026] where:

$$t^{MAX} = \max \{t_1, t_2, \dots, t_n\} \quad (21)$$

[0027] As illustrated by FIG. 3, unlike the constant mode averager, the linear mode averager is sensitive to the input signal trend. That is, the constant mode averager provides a constant fit to the input values, whereas the linear mode averager provides a linear fit to the input values that corre-

sponds to the input value trend. As a result, the output of the linear mode averager output responds faster to changes in the input signal than does the output of the constant mode averager. The time lag or delay between the output of the constant mode averager and the output of the linear mode averager can be visualized by comparing the time difference 360 between the constant mode averager output value 340 and the linear mode averager output value 350.

[0028] FIGS. 4-6 illustrate further comparisons between the constant mode averager and the linear mode averager. FIG. 4 depicts a noise-corrupted input signal 410, which increases in frequency with time. FIGS. 5-6 depict the corresponding noise-free signal 400. FIG. 5 also depicts the constant mode averager output 500 in response to the input signal 410, with the noise-free signal 400 shown for reference. FIG. 6 depicts the linear mode averager output 600 in response to the input signal 410, with the noise-free signal 400 also shown for reference. As shown in FIG. 5, the constant mode averager output 500 suppresses noise from the input signal 410 (FIG. 4) but displays increasing time lag and amplitude deviation from the input signal 400 as frequency increases. As shown in FIG. 6, the linear mode averager output 600 tends to track the input signal 400 but also tracks a portion of the noise on the input signal 410.

[0029] FIGS. 4-6 suggest that it would be advantageous to have an averager that has variable characteristics between those of the linear mode averager and those of the constant mode averager, depending on signal confidence. Specifically, it would be advantageous to have a variable mode averager that can be adjusted to track input signal features with a minimal output time lag when signal confidence is high and yet adjusted to smooth an input signal when signal confidence is low. Further, it would be advantageous to have a variable mode averager that can be adjusted so as not to track superfluous input signal features regardless of signal confidence.

[0030] One aspect of the present invention is a variable mode averager having a buffer that stores weighted input values. A mode input specifies a time value relative to the input values. A processor is coupled to the buffer, and the processor is configured to provide an estimate of the input values that corresponds to the time value. In a particular embodiment, the mode input is adjustable so that the estimate varies between that of a smoother and that of a forward predictor of the input values. In another embodiment, the mode input is adjustable so that the estimate varies between that of a smoother and that of a filter of the input values. In yet another embodiment, the mode input is adjustable so that the estimate varies between that of an average of the input values and that of a filter of the input values. The mode input may be adjustable based upon a characteristic associated with the input values, such as a confidence level. In one variation of that embodiment, the estimate can be that of a smoother when the confidence level is low and that of a filter when the confidence level is high. The estimate may occur along a curve-fit of the input values at the time value. In one embodiment, the curve-fit is a linear LMS fit to the input values.

[0031] Another aspect of the present invention is a signal averaging method. The method includes identifying signal values and determining weights corresponding to the signal values. The method also includes computing a trend of the signal values adjusted by the weights. Further, the method includes specifying a time value relative to the signal values based upon a characteristic associated with the signal values and estimating the signal values based upon the trend evalu-

ated at the time value. The method may also incorporate the steps of determining a confidence level associated with the signal values and specifying the time value based upon the confidence level. In one embodiment, the trend is a linear LMS fit to the signal values adjusted by the weights. In that case, the time value may generally correspond to the maximum time of the signal values when the confidence level is high and generally correspond to the weighted average time of the signal values when the confidence level is low.

[0032] Yet another aspect of the present invention is a signal averaging method having the steps of providing an input signal, setting a mode between a first mode value and a second mode value and generating an output signal from an estimate of the input signal as a function of said mode. The output signal generally smoothes the input signal when the mode is proximate the first mode value, and the output signal generally tracks the input signal when the mode is proximate the second mode value. The method may also include determining a characteristic of the input signal, where the setting step is a function of the characteristic. In one embodiment, the characteristic is a confidence level relating to the input signal. In another embodiment, the setting step incorporates the sub-steps of setting the mode proximate the first mode value when the confidence level is low and setting the mode proximate the second mode value when the confidence level is high. In another embodiment, the input signal is a physiological measurement and the setting step comprises setting the mode proximate the first mode value when the measurement is corrupted with noise or signal artifacts and otherwise setting the mode proximate the second mode value so that the output signal has a fast response to physiological events.

[0033] A further aspect of the present invention is a signal averager having an input means for storing signal values, an adjustment means for modifying the signal values with corresponding weights, a curve fitting means for determining a trend of the signal values, and an estimate means for generating an output value along the trend. The signal averager may further have a mode means coupled to the estimate means for variably determining a time value at which to generate the output value.

[0034] For purposes of summarizing the invention, certain aspects, advantages and novel features of the invention have been described herein. Of course, it is to be understood that not necessarily all such aspects, advantages or features will be embodied in any particular embodiment of the invention.

BRIEF DESCRIPTION OF THE DRAWINGS

[0035] A general architecture that implements the various features of the invention will now be described with reference to the drawings. The drawings and the associated descriptions are provided to illustrate embodiments of the invention and not to limit the scope of the invention. Throughout the drawings, reference numbers are re-used to indicate correspondence between referenced elements. In addition, the first digit of each reference number indicates the figure in which the element first appears.

[0036] FIG. 1 is a time graph depicting the output of conventional smoother, filter and predictor signal processors;

[0037] FIG. 2A is an amplitude versus time graph depicting the output of a conventional constant mode averager;

[0038] FIG. 2B is an amplitude versus time graph depicting the output of a conventional linear mode averager;

[0039] FIG. 3 is an amplitude versus time graph comparing the outputs of a constant mode averager and a linear mode averager;

[0040] FIG. 4 is an amplitude versus time graph depicting a noisy input signal;

[0041] FIG. 5 is an amplitude versus time graph depicting a constant mode averager output signal corresponding to the input signal of FIG. 4;

[0042] FIG. 6 is an amplitude versus time graph depicting a linear mode averager output signal corresponding to the input signal of FIG. 4;

[0043] FIG. 7 is an amplitude versus time graph illustrating the characteristics of one embodiment of the variable mode averager;

[0044] FIG. 8 is a flow chart of a variable mode averager embodiment;

[0045] FIG. 9 is a block diagram illustrating a variable mode averager applied to a pulse oximeter; and

[0046] FIG. 10 is an oxygen saturation output versus time graph for a pulse oximeter utilizing a variable mode averager.

[0047] FIG. 11 is a flow chart of an output value selection process of a signal processor, according to an embodiment of the invention.

[0048] FIG. 12 is an amplitude versus time graph depicting exemplary potential output values of the output value selection process of FIG. 11, according to an embodiment of the invention.

DETAILED DESCRIPTION OF THE PREFERRED EMBODIMENTS

[0049] FIG. 7 illustrates the output characteristics of a variable mode averager according to the present invention. The output of the variable mode averager is a mode-dependent weighted linear average (MWLA) defined as

$$v^{MWLA} = mode \cdot \frac{\sigma_w^2}{\sigma_n^2} (t^{MAX} - t^{WA}) + v^{WA} \tag{22}$$

[0050] Equation (22) is a modified form of equation (20), which is motivated by equations (2) and (19) along with recognition of the relationships in Table 1.

TABLE 1

VARIABLE MODE AVERAGER OUTPUT			
	mode = 0	mode = 1	any mode \exists 0
Processing Function	Constant Mode Averager	Linear Mode Averager	Variable Mode Averager
Output	v^{WA}	v^{WLA}	v^{MWLA}
Defining Formula	Equation (2)	Equation (20)	Equation (22)
Processing Method	Weighted Average	LMS Linear Fit	FIG. 8

[0051] As shown in Table 1, the Variable Mode Averager in accordance with the present invention includes the constant mode averager processing function and the linear mode averager processing function, which are known processing functions. As further shown in Table 1, the Variable Mode Averager of the present invention also includes a variable mode averager processing function, which will be described below.

[0052] As shown in Table 1, if mode=0, the variable mode averager output is v^{WA} , the output of the constant mode aver-

ager function, which utilizes a weighted average of the input signal values. If mode=1, the variable mode averager output is V^{WLA} , the output of the linear mode averager function, which utilizes a LMS linear fit to the input signal values. If $0 < \text{mode} < 1$, then the variable mode averager output is V^{MWLA} and has output characteristics that are between that of the constant mode averager and the linear mode averager. In addition, if mode>1, then the variable mode averager behaves as a forward predictor.

[0053] As shown in FIG. 7, the variable mode averager output **720** is an estimate of the input values at a selected time along the linear fit **710**, which indicates a trend of the input values. Assuming $0 < \text{mode} < 1$, the mode variable determines the equivalent time **730** between t^{WA} and t^{MAX} for which the estimate is evaluated, yielding an output value **740** between V^{WA} and V^{WLA} . Thus, the mode variable acts to parametrically vary the time delay between the input and output signals of the variable mode averager, along with associated output characteristics. If mode=0, the time delay **360** (FIG. 3) is that of the constant mode averager. If mode=1, there is no time delay. If mode>1, the variable mode averager is predicting a future input value based on n past values. In this manner, the variable mode averager can be used to advantageously adjust between the smoothing characteristics of the constant mode averager and the tracking characteristics of the linear mode averager, as described above with respect to FIGS. 4-6. The variable mode control determines how much of each particular characteristic to use for a particular input signal and application. For example, for time periods when the input signal has low confidence, mode can be set further towards zero, although with a time lag penalty. For time periods when the input signal has high confidence or when minimum time lag is required, mode can be set further towards one, or even to a value greater than one.

[0054] The variable mode averager has been described in terms of weighted input values. One of ordinary skill, however, will recognize that the present invention includes the case where all of the weights are the same, i.e., where the input values are equally weighted or unweighted. Further, although the variable mode averager has been described in terms of a linear mode averager, one of ordinary skill in the art will recognize that a variable mode averager could also be based on non-linear curve fits, such as exponential or quadratic curves indicating a non-linear trend of the input signal. In addition, one of ordinary skill will understand that the variable mode averager can be implemented to operate on continuous data as well as infinitely long data. Also, a variable mode averager based upon a linear fit by some criteria other than LMS; a variable mode averager using any mode value, including negative values; and a variable mode averager based upon a linear fit where $t^{min} = \min \{t_1, t_2, \dots, t_n\}$ is substituted for t^{MAX} in equation (22) are all contemplated as within the scope of the present invention.

[0055] FIG. 8 illustrates one embodiment **800** of a variable mode signal averager. After an entry point **802**, variables are initialized to zero in a block **808**. Next, in a block **812**, the sums of various parameters are calculated by summing the products of corresponding values in each of three buffers: an input data buffer, value[i]; a weight buffer, weight[i]; and a time value buffer, time[i]. In addition, the weight[i] values are summed. These sums are calculated over the entire length of each buffer, representing a single time window of n values. The calculations are performed by incrementing a loop counter i in a block **810** and reentering the block **812**. The

loop counter i specifies a particular value in each buffer. Each time through the block **812**, the variable mode signal averager generates products of buffer values and adds the results to partial sums. After completing the partial sums, the variable mode signal averager then determines if the ends of the buffers have been reached in a decision block **814** by comparing the incremented value of i to the size of the buffer. If the ends of the buffers have not been reached, the variable mode averager increments the loop counter i and reenters the block **812**; otherwise, the variable mode averager continues to a decision block **816**.

[0056] In the decision block **816**, a check is made whether the sum of the weights, sumw, is greater than zero. If so, each of the sums of the products from the block **812** is divided by sumw in a block **820**. In the block **820**, the parameters computed are:

[0057] sumwv, the weighted average value of equation (2);

[0058] sumwt, the weighted average time of equation (10);

[0059] sumwvt, the weighted average product of value and time; and

[0060] sumwt2, the weighted average product of time squared.

[0061] The sumwt2 parameter from the block **820** is then used in a block **822** to calculate an autocovariance sigma2tt in accordance with equation (18b). If, in a decision block **824**, a determination is made that the autocovariance is not greater than zero, then in a decision block **825**, a determination is made whether the sum of the weights is greater than zero. If, in the decision block **825**, the sum of the weights is not greater than zero, then an output value, out, which was initialized to zero in the block **808**, is returned as a zero value at a termination point **804**. Otherwise, if, in the decision block **825**, a determination is made that the sum of the weights is greater than zero, then in a block **826**, the value of the sum of the weights is assigned to the output value, out, and the output value is then returned at the termination point **804**.

[0062] If, in the decision block **824**, the autocovariance is determined to be greater than zero, then in a block **827**, the sumwvt parameter from the block **820** is used to calculate a crossvariance signal sigma2vt in accordance with equation (18a). Thereafter, the maximum time, t^{MAX} , as defined in equation (21), is determined by finding the largest time value in the time buffer, time[i]. In particular, in a block **829**, the loop counter, i, is reinitialized to zero and the value of t^{MAX} is initialized to zero. Next, in a decision block **832**, the current value of t^{MAX} is compared to the current value of the time buffer indexed by the loop counter, i. If the current value of t^{MAX} is not less than the current value of the time buffer or if the current weight value indexed by i is not greater than zero, then t^{MAX} is not changed and a block **834** is bypassed. On the other hand, if the current value of t^{MAX} is less than the current time value and if the current weight value is greater than zero, then the block **834** is entered, and the value of t^{MAX} is replaced with the current time value time[i]. In either case, in a decision block **838**, the loop counter, i, is compared to the buffer size, and, if the loop counter, i, is less than the buffer size, the loop counter, i, is incremented in a block **830**, and the comparisons are again made in the decision block **832**.

[0063] When, in the decision block **838**, it is determined that the loop counter, i, has reached the buffer size, the variable mode averager proceeds to a block **840** with the largest value of time[i] saved as the value of t^{MAX} . In the block **840**, a single output value, out, is computed in accordance with equation (22). Thereafter, the output value, out, is limited to

the range of values in the input data buffer, value[j]. This is accomplished by comparing out to the maximum and minimum values in the data buffer. First, in a block 850, the maximum of the value buffer is determined. Then, in a decision block 852, the maximum of the value buffer is compared to out. If out is bigger than the maximum of the value buffer, then, in a block 854, out is limited to the maximum value in the buffer. Otherwise, the block 854 is bypassed, and out remains as previously calculated in the block 840. Thereafter, in a block 860, the minimum of the value buffer is determined. The minimum of the value buffer is compared to out in a decision block 862. If out is smaller than the minimum of the value buffer, then, in a block 864, out is set to the minimum value in the buffer. Otherwise, the block 864 is bypassed, and out is not changed. The value of out determined by the block 840, the block 852 or the block 864 is then returned from the routine via the termination point 804.

[0064] In one embodiment, the process described with respect to FIG. 8 is implemented as firmware executing on a digital signal processor. One of ordinary skill in the art will recognize that the variable mode averager can also be implemented as a digital circuit. Further, a variable mode averager implemented as an analog circuit with analog inputs and outputs is also contemplated to be within the scope of the present invention.

[0065] Pulse oximetry is one application that can effectively use signal processing techniques to provide caregivers with improved physiological measurements. Pulse oximetry is a widely accepted noninvasive procedure for measuring the oxygen saturation level of arterial blood, an indicator of oxygen supply. Early detection of low blood oxygen is critical in the medical field, for example in critical care and surgical applications, because an insufficient supply of oxygen can result in brain damage and death in a matter of minutes. Pulse oximeter systems are described in detail in U.S. Pat. No. 5,632,272, U.S. Pat. No. 5,769,785, and U.S. Pat. No. 6,002,952, which are assigned to the assignee of the present invention and which are incorporated by reference herein.

[0066] FIG. 9 depicts a general block diagram of a pulse oximetry system 900 utilizing a variable mode averager 960. A pulse oximetry system 900 consists of a sensor 902 attached to a patient and a monitor 904 that outputs desired parameters 982 to a display 980, including blood oxygen saturation, heart rate and a plethysmographic waveform. Conventionally, a pulse oximetry sensor 902 has both red (RED) and infrared (IR) light-emitting diode (LED) emitters (not shown) and a photodiode detector (not shown). The sensor 902 is typically attached to a patient's finger or toe, or to a very young patient's foot. For a finger, the sensor 902 is configured so that the emitters project light through the fingernail and into the blood vessels and capillaries underneath. The photodiode is positioned at the fingertip opposite the fingernail so as to detect the LED transmitted light as it emerges from the finger tissues, producing a sensor output 922 that indicates arterial blood absorption of the red and infrared LED wavelengths.

[0067] As shown in FIG. 9, the sensor output 922 is coupled to analog signal conditioning and an analog-to-digital conversion (ADC) circuit 920. The signal conditioning filters and amplifies the analog sensor output 922, and the ADC provides discrete signal values to the digital signal processor 950. The signal processor 950 provides a gain control 952 to amplifiers in the signal conditioning circuit 920. The signal processor 950 also provides an emitter control 954 to a digital-to-analog

conversion (DAC) circuit 930. The DAC 930 provides control signals for the emitter current drivers 940. The emitter drivers 940 couple to the red and infrared LEDs in the sensor 902. In this manner, the signal processor 950 can alternately activate the sensor LED emitters and read the resulting output 922 generated by the photodiode detector.

[0068] The digital signal processor 950 determines oxygen saturation by computing the differential absorption by arterial blood of the red and infrared wavelengths emitted by the sensor 902. Specifically, the ADC 920 provides the processor 950 with a digitized input 924 derived from the sensor output 922. Based on this input 924, the processor 950 calculates ratios of detected red and infrared intensities. Oxygen saturation values, v_i , are empirically determined based on the calculated red and infrared ratios. These values are an input signal 962 to the variable mode averager 960. Each of the input values, v_i , are associated with weights, w_i , which form a second input 964 to the averager 960. The individual weights, w_i , are indicative of the confidence in particular ones of the corresponding saturation values, v_i . A third input 974 sets the mode of the averager 960. The variable mode averager 960 processes the values, v_i , weights, w_i , and mode as described above with respect to FIGS. 7-8 to generate values, z_i . The values z_i are the averager output 968, from which is derived the saturation output 982 to the display 980.

[0069] The mode signal may be generated by an external source (not shown) or it may be generated by another function within the digital signal processor. For example, mode may be generated from the confidence level of the input signal as illustrated in FIG. 9. FIG. 9 illustrates a signal confidence input 972 to a mode control process 970. The mode control process 970 maps the signal confidence input 972 to the mode input 974 of the variable mode averager 960. When the signal confidence is low, the mode control 970 sets mode to a relatively small value. Depending on the application, mode may be set close to zero. When the signal confidence is high, the mode control 970 sets mode to a relatively large value. Some applications may prefer a mode of one for a high signal confidence, but this is not a requirement. When the signal confidence is neither high nor low, mode is set to an intermediate value (in some applications, mode may be set to a value between zero and one) empirically to achieve a reasonable tradeoff between a fast saturation output response and saturation accuracy.

[0070] The signal quality of pulse oximetry measurements is adversely affected by patients with low perfusion of blood, causing a relatively small detected signal, ambient noise, and artifacts caused by patient motion. The signal confidence input 972 is an indication of the useful range of the pulse oximetry algorithms used by the digital signal processor 950 as a function of signal quality. This useful range is extended by signal extraction techniques that reduce the effects of patient motion, as described in U.S. Pat. No. 5,632,272, U.S. Pat. No. No. 5,769,785, and U.S. Pat. No. 6,002,952, referenced above. Signal confidence is a function of how well the sensor signal matches pulse oximetry algorithm signal models. For example, the red and infrared signals should be highly correlated and the pulse shapes in the pulsatile red and infrared signals should conform to the shape of physiological pulses, as described in U.S. patent application Ser. No. 09/471,510 filed Dec. 23, 1999, entitled Plethysmograph Pulse Recognition Processor, which is assigned to the assignee of the present invention and which is incorporated by reference herein. As a particular example, signal confi-

dence can be determined by measuring pulse rate and signal strength. If the measured signal strength is within an expected range for the measured pulse rate, then the confidence level will be high. On the other hand, if the measured signal strength is outside the expected range (e.g., too high for the measured pulse rate), then the confidence level will be low. Other measured or calculated parameters can be advantageously used to set the confidence level.

[0071] FIG. 10 illustrates the oxygen saturation output of a pulse oximeter utilizing a variable mode averager, as described above with respect to FIG. 9. A first output 1010 illustrates oxygen saturation versus time for input oxygen saturation values processed by a conventional weighted averager or, equivalently, by a variable mode averager 960 with $\text{mode} \approx 0$. A second output 1020 illustrates oxygen saturation versus time for the variable mode averager 960 with $\text{mode} \approx 1$. Each output 1010, 1020 indicates exemplary desaturation events occurring around a first time 1030 and a second time 1040. The desaturation events correspond to a patient experiencing a potentially critical oxygen supply shortage due to a myriad of possible physiological problems. With $\text{mode} \approx 1$, the variable mode averager responds to the onset of the desaturation events with less lag time 1050 than that of the conventional weighted average. Further, the variable mode averager responds to the full extent of the desaturations 1060 whereas the conventional weighted average does not. When signal confidence is low, the variable mode averager is adjusted to provide similar smoothing features to those of a conventional weighted average. When signal confidence is high, however, the variable mode averager is advantageously adjusted to respond faster and more accurately to a critical physiological event. The fast response advantage of the variable mode averager has other physiological measurement applications, such as blood-pressure monitoring and ECG.

[0072] The variable mode averager has been disclosed in detail in connection with various embodiments of the present invention. One of ordinary skill in the art will appreciate many variations and modifications within the scope of this invention.

[0073] Thus, the variable mode averager disclosed in the foregoing advantageously allows a signal processor the ability to reduce a window of input values of, for example, a noisy signal, to a linear fit of estimates of the desired signal, where a selected output value from the estimates corresponds at least in part to the selection of a time or mode. The mode can correspond, for example, to a degree of confidence that the most recently received input signal is an accurate representation of the desired signal. However, a skilled artisan will recognize from the disclosure herein that other mechanisms can be used to reduce a set of input values to one or more appropriate output values.

[0074] For example, FIG. 11 illustrates a flow chart of an output value selection process 1100 of a signal processor, according to an embodiment of the invention. As shown in FIG. 11, the process 1100 includes BLOCK 1110, where the signal processor reduces a set or window of input values to one or more or a set of estimates such as the foregoing linear fit of the variable mode averager, or the like. The process 1100 then moves to BLOCK 1112, where the processor selects a time based, for example, on an indication of confidence that the set of input values represents a desired signal. The process 1100 in BLOCK 1114 then determines the output value from the one or more, or set of estimates, which corresponds to the selected time.

[0075] As will be appreciated by an artisan from the disclosure herein, a wide variety of processes or mechanisms can be used to reduce a set or window of input data to a set of estimates. For example, the processor can execute the foregoing variable mode averager, or other more conventional signal processing techniques, such as, for example, simple averaging, weighted averaging, linear averaging, filtering, prediction, or the like to reduce the set of input data before selecting an appropriate time using the mode or signal confidence.

[0076] According to one embodiment, the processor can reduce input data through segmentation of a window of input values. For example, FIG. 12 illustrates an amplitude versus time graph depicting an input signal 1210, including a window 1212 of input values. According to one embodiment, the input signal 1210 comprises, for example, a desired signal corrupted by noise or a signal having superfluous features. FIG. 12 shows an example of reduction of the input values corresponding to the window 1212 to the linear fit 1214 of estimates using the foregoing variable mode averager. As disclosed in the foregoing, when $0 < \text{mode} < 1$, the mode variable determines the equivalent time along the linear fit of estimates for which an output estimate can be evaluated, thereby yielding an output value between v^{WA} and v^{WLA} .

[0077] However, FIG. 12 also shows reduction of the input values using segmentation. For example, a signal processor can segment the window 1212 of input values into a plurality of segments, e.g., Segments A1, A2, A3, and A4. A artisan will recognize from the disclosure herein that the use of four segments in FIG. 12 is for illustration only, and the number of segments can be selected based on a number of factors, such as, for example, the number of input values in the window, signal processing speed and capacity, experimental results, or the like.

[0078] According to one embodiment, the signal processor then determines one or more or a set of estimates corresponding to each segment. For example, in a straightforward implementation, the signal processor may select simple weighted averages 1216, 1218, 1220, 1222, as estimates for each of the Segments A1, A2, A3, and A4, respectively, of the window 1212 of input values. However, an artisan will recognize from the disclosure herein that the estimates for each segment may range in complexity from simple selection of one or more of the input values, to more complex calculations, such as application of the foregoing variable mode averager or the like for the input values of each segment. Moreover, the artisan will recognize from the disclosure herein that the signal confidence indicator could be used to select one, some, or all of the input values corresponding to one, some, or all, of the segments for the generation of the estimate values.

[0079] Once the estimates for each segment are determined, the signal processor selects a time corresponding to a degree of confidence that the input values represent a desired signal. A signal confidence indicator representative of whether the more recently received input signal values are accurate representations of a desired signal can be derived from, for example, an analysis of the amount of noise in the signal, comparing the signal to expected patterns or templates, or the like. The analysis of noise can include a measurement of the entropy of the signal, adherence of the signal to predetermined mathematical models based on a priori information about the expected or desired signal, or the like.

[0080] In the example illustrated in FIG. 12, the signal processor may have higher confidence that the estimates from

the segmentation are representative of the desired signal, and therefore choose a time **1224** where the estimates **1216-1222** are to be evaluated. According to an embodiment using a more straightforward reduction of the segments, such as, for example, the simple weighted averaging, the signal processor may interpolate between estimates, such as, output value **1228**. When more complex mechanisms are used to reduce the input data, determination of the output value **1228** may be directly calculated, such as, for example, calculation of the output value using the variable mode averager. A skilled artisan will also recognize from the disclosure herein that the output value **1228** may comprise an interpolation between more complex estimates, such as, for example, zero, first, second, etc. order interpolation.

[0081] Selection of the time **1224** allows the signal processor to slide the output value along, for example, the exemplary line **1214** or one of the segment estimates **1216-1222**, thereby providing an output value deemed likely to indicate the value of the desired signal for the most recent input value of the time window **1212**. For example, as disclosed in the foregoing, when the signal confidence indicator represents a higher confidence in the input values, the output value **1228** may slide toward the most recent input values, whereas the output value **1228** may slide in the opposite direction during a time of lower signal confidence.

[0082] The signal processing techniques disclosed in the foregoing, which use a confidence measure to select an output value from a set of estimates of a window of input values, is particularly applicable to the monitoring of critical physiological parameters in patient-care settings. When applied to pulse oximeter oxygen saturation measurements, the mode parameter can be varied in real-time to achieve a tradeoff between the suppression of false alarms and signal artifacts and the immediate detection of life threatening oxygen desaturation events. For example, during the monitoring of physiological parameters, it is often common for motion artifacts or other abnormalities to appear in the input value stream. Such abnormalities often decrease the confidence measure, or mode, being used by the signal processor. As disclosed in the foregoing, a lower signal confidence may lead to the signal processor selecting a smoothed output estimate for a specific time window, such as for example, time windows ranging from approximately 15 seconds to over 1 minute, thereby avoiding crossing over alarm-activating output thresholds. Alternatively, as discussed with reference to FIG. 10, a signal abnormality accompanied by high signal confidence leads the signal processor to the selection of an output estimate that more accurately reflects the extent of a potentially life threatening desaturation event, thereby ensuring an appropriate alarm activation.

[0083] Although the foregoing invention has been described in terms of certain preferred embodiments, other embodiments will be apparent to those of ordinary skill in the

art from the disclosure herein. Additionally, other combinations, omissions, substitutions and modifications will be apparent to the skilled artisan in view of the disclosure herein. Accordingly, the present invention is not intended to be limited by the reaction of the preferred embodiments which disclose by way of example only, but is to be defined by reference to the appended claims.

[0084] Additionally, all publications, patents, and patent applications mentioned in this specification are herein incorporated by reference to the same extent as if each individual publication, patent, or patent application was specifically and individually indicated to be incorporated by reference.

1-20. (canceled)

21. An apparatus for selecting output parameter values, the apparatus comprising:

a processor configured to:

- receive an input physiological signal from a sensor coupled with a living being;
- calculate parameter values from the input physiological signal;
- select between a first parameter value from a trend of the parameter values and a second parameter value representing a constant average value of the parameter values within a time window, the trend having a non-zero slope in the time window; and
- output the selected parameter value.

22. The apparatus of claim **21**, wherein the processor is further configured to select the first parameter value from the trend of the parameter values at a most recent time in the time window.

23. The apparatus of claim **21**, wherein the processor is further configured to select the first parameter value from the trend of the parameter values at a time in the time window other than a most recent time.

24. The apparatus of claim **21**, wherein the processor is further configured to select the first parameter value in the time window and the second parameter value in a second time window.

25. The apparatus of claim **21**, wherein the processor is further configured to calculate a signal confidence using the input physiological signal.

26. The apparatus of claim **25**, wherein the processor is further configured to make said selection using the signal confidence.

27. The apparatus of claim **26**, wherein the processor is further configured to select the first parameter value when the signal confidence is high and the second parameter value when the signal confidence is low.

28. The apparatus of claim **21**, wherein the parameter values comprise oxygen saturation values.

29. The apparatus of claim **21**, wherein the parameter values comprises blood pressure values.

* * * * *

专利名称(译)	可变指示估计器		
公开(公告)号	US20150351697A1	公开(公告)日	2015-12-10
申请号	US14/830211	申请日	2015-08-19
[标]申请(专利权)人(译)	梅西莫股份有限公司		
申请(专利权)人(译)	Masimo公司		
当前申请(专利权)人(译)	Masimo公司		
[标]发明人	WEBER WALTER M AL ALI AMMAR CAZZOLI LORENZO		
发明人	WEBER, WALTER M. AL-ALI, AMMAR CAZZOLI, LORENZO		
IPC分类号	A61B5/00 A61B5/021 A61B5/1455 A61B5/145 G06F17/00 G06F17/18		
CPC分类号	A61B5/7271 A61B5/14551 A61B5/6829 A61B5/6826 A61B5/021 A61B5/0002 A61B5/1455 A61B5/6838 A61B5/72 A61B5/7207 A61B5/7239 G06K9/0051		
外部链接	Espacenet USPTO		

摘要(译)

变量指示估计器，其确定表示一组输入数据的输出值。例如，估计器可以将输入数据减少到期望信号的估计，选择时间，并且根据估计和时间确定输出值。在一个实施例中，使用一个或多个可调节信号置信参数来确定时间，确定沿着估计在何处计算输出值。通过改变参数，输出值的特性是可变的。例如，当输入信号置信度低时，调整参数，使得输出值是输入信号的平滑表示。当输入信号置信度高时，调整参数，使得输出值对输入信号具有更快和更准确的响应。

