



US010617874B2

(12) **United States Patent**
Kane et al.

(10) **Patent No.: US 10,617,874 B2**
(45) **Date of Patent: *Apr. 14, 2020**

(54) **SYSTEMS AND METHODS FOR ACTIVITY LEVEL PACING**

(56) **References Cited**

(71) Applicant: **CARDIAC PACEMAKERS, INC.**, St. Paul, MN (US)

3,835,864 A 9/1974 Rasor et al.
3,943,936 A 3/1976 Rasor et al.

(Continued)

(72) Inventors: **Michael J. Kane**, St. Paul, MN (US);
Paul Huelskamp, St. Paul, MN (US)

FOREIGN PATENT DOCUMENTS

(73) Assignee: **CARDIAC PACEMAKERS, INC.**, St. Paul, MN (US)

AU 2008279789 B2 10/2011
AU 2008329620 B2 5/2014

(Continued)

(*) Notice: Subject to any disclaimer, the term of this patent is extended or adjusted under 35 U.S.C. 154(b) by 270 days.

OTHER PUBLICATIONS

This patent is subject to a terminal disclaimer.

US 8,886,318 B2, 11/2014, Jacobson et al. (withdrawn)
(Continued)

(21) Appl. No.: **15/797,797**

Primary Examiner — Alyssa M Alter

(22) Filed: **Oct. 30, 2017**

(74) *Attorney, Agent, or Firm* — Seager, Tufte & Wickhem LLP

(65) **Prior Publication Data**

US 2018/0117338 A1 May 3, 2018

(57) **ABSTRACT**

Related U.S. Application Data

Systems, devices, and methods for pacing a heart of a patient are disclosed. An illustrative method may include determining a motion level of the patient using a motion sensor of an implantable medical device secured relative to a patient's heart, and setting a pacing rate based at least in part on the patient's motion level. The patient's motion level may be determined by, for example, comparing the motion level sensed by the motion sensor during a current heart beat to a motion level associated with one or more previous heart beats. Noise may occur in the motion level measurements during those heart beats that transition between an intrinsically initiated heart beat and pace initiated heart beat. Various techniques may be applied to the motion level measurements to help reduce the effect of such noise.

(60) Provisional application No. 62/424,876, filed on Nov. 21, 2016, provisional application No. 62/415,132, filed on Oct. 31, 2016.

(51) **Int. Cl.**
A61N 1/365 (2006.01)
A61N 1/375 (2006.01)
(Continued)

(52) **U.S. Cl.**
CPC *A61N 1/36542* (2013.01); *A61B 5/1116* (2013.01); *A61B 5/1118* (2013.01);
(Continued)

(58) **Field of Classification Search**
CPC A61N 1/36542
See application file for complete search history.

20 Claims, 13 Drawing Sheets

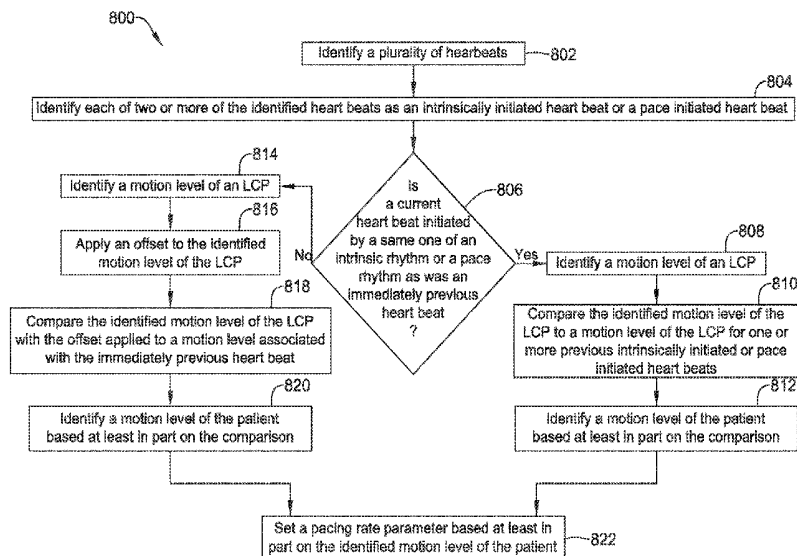

(51)	Int. Cl.		5,305,760 A	4/1994	McKown et al.
	<i>A61B 5/11</i>	(2006.01)	5,312,439 A	5/1994	Loeb
	<i>A61B 5/00</i>	(2006.01)	5,313,953 A	5/1994	Yomtov et al.
	<i>A61N 1/372</i>	(2006.01)	5,314,459 A	5/1994	Swanson et al.
(52)	U.S. Cl.		5,318,597 A	6/1994	Hauck et al.
	CPC	<i>A61B 5/686</i> (2013.01); <i>A61B 5/7217</i>	5,324,316 A	6/1994	Schulman et al.
		(2013.01); <i>A61N 1/36535</i> (2013.01); <i>A61N</i>	5,331,966 A	7/1994	Bennett et al.
		<i>1/3756</i> (2013.01); <i>A61N 1/37288</i> (2013.01);	5,334,222 A	8/1994	Salo et al.
		<i>A61N 1/37512</i> (2017.08); <i>A61B 2560/0223</i>	5,342,408 A	8/1994	deCoriolis et al.
		(2013.01); <i>A61B 2562/0219</i> (2013.01)	5,350,409 A	9/1994	Stoop et al.
			5,370,667 A	12/1994	Alt
			5,372,606 A	12/1994	Lang et al.
			5,376,106 A	12/1994	Stahmann et al.
			5,383,915 A	1/1995	Adams
(56)	References Cited		5,388,578 A	2/1995	Yomtov et al.
	U.S. PATENT DOCUMENTS		5,404,877 A	4/1995	Nolan et al.
			5,405,367 A	4/1995	Schulman et al.
			5,411,031 A	5/1995	Yomtov
			5,411,525 A	5/1995	Swanson et al.
			5,411,535 A	5/1995	Fujii et al.
			5,413,592 A	5/1995	Schroepffel
			5,456,691 A	10/1995	Snell
			5,458,622 A	10/1995	Alt
			5,466,246 A	11/1995	Silvian
			5,468,254 A	11/1995	Hahn et al.
			5,472,453 A	12/1995	Alt
			5,522,866 A	6/1996	Fernald
			5,540,727 A	7/1996	Tockman et al.
			5,545,186 A	8/1996	Olson et al.
			5,545,202 A	8/1996	Dahl et al.
			5,571,146 A	11/1996	Jones et al.
			5,591,214 A	1/1997	Lu
			5,593,431 A	1/1997	Sheldon
			5,620,466 A	4/1997	Haefner et al.
			5,634,938 A	6/1997	Swanson et al.
			5,649,968 A	7/1997	Alt et al.
			5,662,688 A	9/1997	Haefner et al.
			5,674,259 A	10/1997	Gray
			5,683,426 A	11/1997	Greenhut et al.
			5,683,432 A	11/1997	Goedeke et al.
			5,706,823 A	1/1998	Wodlinger
			5,709,215 A	1/1998	Perttu et al.
			5,720,770 A	2/1998	Nappholz et al.
			5,728,154 A	3/1998	Crossett et al.
			5,741,314 A	4/1998	Daly et al.
			5,741,315 A	4/1998	Lee et al.
			5,752,976 A	5/1998	Duffin et al.
			5,752,977 A	5/1998	Grevious et al.
			5,755,736 A	5/1998	Gillberg et al.
			5,759,199 A	6/1998	Snell et al.
			5,774,501 A	6/1998	Halpern et al.
			5,792,195 A	8/1998	Carlson et al.
			5,792,202 A	8/1998	Rueter
			5,792,203 A	8/1998	Schroepffel
			5,792,205 A	8/1998	Alt et al.
			5,792,208 A	8/1998	Gray
			5,814,089 A	9/1998	Stokes et al.
			5,827,216 A	10/1998	Igo et al.
			5,836,985 A	11/1998	Rostami et al.
			5,836,987 A	11/1998	Baumann et al.
			5,842,977 A	12/1998	Lesho et al.
			5,855,593 A	1/1999	Olson et al.
			5,873,894 A	2/1999	Vandegriff et al.
			5,891,184 A	4/1999	Lee et al.
			5,897,586 A	4/1999	Molina
			5,899,876 A	5/1999	Flower
			5,899,928 A	5/1999	Sholder et al.
			5,919,214 A	7/1999	Ciciarelli et al.
			5,935,078 A	8/1999	Feierbach
			5,941,906 A	8/1999	Barreras, Sr. et al.
			5,944,744 A	8/1999	Paul et al.
			5,954,757 A	9/1999	Gray
			5,978,713 A	11/1999	Prutchi et al.
			5,991,660 A	11/1999	Goyal
			5,991,661 A	11/1999	Park et al.
			5,999,848 A	12/1999	Gord et al.
			5,999,857 A	12/1999	Weijand et al.
			6,016,445 A	1/2000	Baura
			6,026,320 A	2/2000	Carlson et al.

(56)

References Cited

U.S. PATENT DOCUMENTS

6,029,085	A	2/2000	Olson et al.	6,490,487	B1	12/2002	Kraus et al.
6,041,250	A	3/2000	DePinto	6,498,951	B1	12/2002	Larson et al.
6,044,298	A	3/2000	Salo et al.	6,507,755	B1	1/2003	Gozani et al.
6,044,300	A	3/2000	Gray	6,507,759	B1	1/2003	Prutchi et al.
6,055,454	A	4/2000	Heemels	6,512,940	B1	1/2003	Brabec et al.
6,073,050	A	6/2000	Griffith	6,522,915	B1	2/2003	Ceballos et al.
6,076,016	A	6/2000	Feierbach	6,526,311	B2	2/2003	Begemann
6,077,236	A	6/2000	Cunningham	6,539,253	B2	3/2003	Thompson et al.
6,080,187	A	6/2000	Alt et al.	6,542,775	B2	4/2003	Ding et al.
6,083,248	A	7/2000	Thompson	6,553,258	B2	4/2003	Stahmann et al.
6,106,551	A	8/2000	Crossett et al.	6,561,975	B1	5/2003	Pool et al.
6,115,636	A	9/2000	Ryan	6,564,807	B1	5/2003	Schulman et al.
6,128,526	A	10/2000	Stadler et al.	6,574,506	B2	6/2003	Kramer et al.
6,141,581	A	10/2000	Olson et al.	6,584,351	B1	6/2003	Ekwall
6,141,588	A	10/2000	Cox et al.	6,584,352	B2	6/2003	Combs et al.
6,141,592	A	10/2000	Pauly	6,597,948	B1	7/2003	Rockwell et al.
6,144,879	A	11/2000	Gray	6,597,951	B2	7/2003	Kramer et al.
6,162,195	A	12/2000	Igo et al.	6,622,046	B2	9/2003	Fraley et al.
6,164,284	A	12/2000	Schulman et al.	6,628,985	B2	9/2003	Sweeney et al.
6,167,310	A	12/2000	Grevious	6,647,292	B1	11/2003	Bardy et al.
6,201,993	B1	3/2001	Kruse et al.	6,666,844	B1	12/2003	Igo et al.
6,208,894	B1	3/2001	Schulman et al.	6,689,117	B2	2/2004	Sweeney et al.
6,211,799	B1	4/2001	Post et al.	6,690,959	B2	2/2004	Thompson
6,221,011	B1	4/2001	Bardy	6,694,189	B2	2/2004	Begemann
6,240,316	B1	5/2001	Richmond et al.	6,704,602	B2	3/2004	Berg et al.
6,240,317	B1	5/2001	Villaseca et al.	6,718,212	B2	4/2004	Parry et al.
6,256,534	B1	7/2001	Dahl	6,721,597	B1	4/2004	Bardy et al.
6,259,947	B1	7/2001	Olson et al.	6,738,670	B1	5/2004	Almendinger et al.
6,266,558	B1	7/2001	Gozani et al.	6,746,797	B2	6/2004	Benson et al.
6,266,567	B1	7/2001	Ishikawa et al.	6,749,566	B2	6/2004	Russ
6,270,457	B1	8/2001	Bardy	6,758,810	B2	7/2004	Lebel et al.
6,272,377	B1	8/2001	Sweeney et al.	6,763,269	B2	7/2004	Cox
6,273,856	B1	8/2001	Sun et al.	6,778,860	B2	8/2004	Ostroff et al.
6,277,072	B1	8/2001	Bardy	6,788,971	B1	9/2004	Sloman et al.
6,280,380	B1	8/2001	Bardy	6,788,974	B2	9/2004	Bardy et al.
6,285,907	B1	9/2001	Kramer et al.	6,804,558	B2	10/2004	Haller et al.
6,292,698	B1	9/2001	Duffin et al.	6,807,442	B1	10/2004	Myklebust et al.
6,295,473	B1	9/2001	Rosar	6,847,844	B2	1/2005	Sun et al.
6,297,943	B1	10/2001	Carson	6,871,095	B2	3/2005	Stahmann et al.
6,298,271	B1	10/2001	Weijand	6,878,112	B2	4/2005	Linberg et al.
6,307,751	B1	10/2001	Bodony et al.	6,885,889	B2	4/2005	Chinchoy
6,312,378	B1	11/2001	Bardy	6,892,094	B2	5/2005	Ousdigian et al.
6,315,721	B2	11/2001	Schulman et al.	6,897,788	B2	5/2005	Khair et al.
6,336,903	B1	1/2002	Bardy	6,904,315	B2	6/2005	Panken et al.
6,345,202	B2	2/2002	Richmond et al.	6,922,592	B2	7/2005	Thompson et al.
6,351,667	B1	2/2002	Godie	6,931,282	B2	8/2005	Esler
6,351,669	B1	2/2002	Hartley et al.	6,934,585	B1	8/2005	Schloss et al.
6,353,759	B1	3/2002	Hartley et al.	6,957,107	B2	10/2005	Rogers et al.
6,358,203	B2	3/2002	Bardy	6,978,176	B2	12/2005	Lattouf
6,361,780	B1	3/2002	Ley et al.	6,985,773	B2	1/2006	Von Arx et al.
6,368,284	B1	4/2002	Bardy	6,990,375	B2	1/2006	Kloss et al.
6,371,922	B1	4/2002	Baumann et al.	7,001,366	B2	2/2006	Ballard
6,398,728	B1	6/2002	Bardy	7,003,350	B2	2/2006	Denker et al.
6,400,982	B2	6/2002	Sweeney et al.	7,006,864	B2	2/2006	Echt et al.
6,400,990	B1	6/2002	Silvian	7,013,178	B2	3/2006	Reinke et al.
6,408,208	B1	6/2002	Sun	7,027,871	B2	4/2006	Burnes et al.
6,409,674	B1	6/2002	Brockway et al.	7,050,849	B2	5/2006	Echt et al.
6,411,848	B2	6/2002	Kramer et al.	7,060,031	B2	6/2006	Webb et al.
6,424,865	B1	7/2002	Ding	7,063,693	B2	6/2006	Guenst
6,434,429	B1	8/2002	Kraus et al.	7,082,336	B2	7/2006	Ransbury et al.
6,438,410	B2	8/2002	Hsu et al.	7,085,606	B2	8/2006	Flach et al.
6,438,417	B1	8/2002	Rockwell et al.	7,092,758	B2	8/2006	Sun et al.
6,438,421	B1	8/2002	Stahmann et al.	7,110,824	B2	9/2006	Amundson et al.
6,440,066	B1	8/2002	Bardy	7,120,504	B2	10/2006	Osyypka
6,441,747	B1	8/2002	Khair et al.	7,130,681	B2	10/2006	Gebhardt et al.
6,442,426	B1	8/2002	Kroll	7,139,613	B2	11/2006	Reinke et al.
6,442,432	B2	8/2002	Lee	7,142,912	B2	11/2006	Wagner et al.
6,443,891	B1	9/2002	Grevious	7,146,225	B2	12/2006	Guenst et al.
6,445,953	B1	9/2002	Bulkes et al.	7,146,226	B2	12/2006	Lau et al.
6,453,200	B1	9/2002	Koslar	7,149,581	B2	12/2006	Goedeke
6,459,929	B1	10/2002	Hopper et al.	7,149,588	B2	12/2006	Lau et al.
6,470,215	B1	10/2002	Kraus et al.	7,158,839	B2	1/2007	Lau
6,471,645	B1	10/2002	Warkentin et al.	7,162,307	B2	1/2007	Patrias
6,480,745	B2	11/2002	Nelson et al.	7,164,952	B2	1/2007	Lau et al.
6,487,443	B2	11/2002	Olson et al.	7,177,700	B1	2/2007	Cox
				7,181,505	B2	2/2007	Haller et al.
				7,184,830	B2	2/2007	Echt et al.
				7,186,214	B2	3/2007	Ness
				7,191,015	B2	3/2007	Lamson et al.

(56)

References Cited

U.S. PATENT DOCUMENTS

7,200,437	B1	4/2007	Nabutovsky et al.	7,713,194	B2	5/2010	Zdeblick
7,200,439	B2	4/2007	Zdeblick et al.	7,713,195	B2	5/2010	Zdeblick
7,206,423	B1	4/2007	Feng et al.	7,729,783	B2	6/2010	Michels et al.
7,209,785	B2	4/2007	Kim et al.	7,734,333	B2	6/2010	Ghanem et al.
7,209,790	B2	4/2007	Thompson et al.	7,734,343	B2	6/2010	Ransbury et al.
7,211,884	B1	5/2007	Davis et al.	7,738,958	B2	6/2010	Zdeblick et al.
7,212,871	B1	5/2007	Morgan	7,738,964	B2	6/2010	Von Arx et al.
7,226,440	B2	6/2007	Gelfand et al.	7,742,812	B2	6/2010	Ghanem et al.
7,228,183	B2	6/2007	Sun et al.	7,742,816	B2	6/2010	Masoud et al.
7,236,821	B2	6/2007	Cates et al.	7,742,822	B2	6/2010	Masoud et al.
7,236,829	B1	6/2007	Farazi et al.	7,743,151	B2	6/2010	Vallapureddy et al.
7,254,448	B2	8/2007	Almendinger et al.	7,747,335	B2	6/2010	Williams
7,260,436	B2	8/2007	Kilgore et al.	7,751,881	B2	7/2010	Cowan et al.
7,270,669	B1	9/2007	Sra	7,758,521	B2	7/2010	Morris et al.
7,272,448	B1	9/2007	Morgan et al.	7,761,150	B2	7/2010	Ghanem et al.
7,277,755	B1	10/2007	Falkenberg et al.	7,761,164	B2	7/2010	Verhoef et al.
7,280,872	B1	10/2007	Mosesov et al.	7,765,001	B2	7/2010	Echt et al.
7,288,096	B2	10/2007	Chin	7,769,452	B2	8/2010	Ghanem et al.
7,289,847	B1	10/2007	Gill et al.	7,783,362	B2	8/2010	Whitehurst et al.
7,289,852	B2	10/2007	Helfinstine et al.	7,792,588	B2	9/2010	Harding
7,289,853	B1	10/2007	Campbell et al.	7,797,059	B1	9/2010	Bornzin et al.
7,289,855	B2	10/2007	Nghiem et al.	7,801,596	B2	9/2010	Fischell et al.
7,302,294	B2	11/2007	Kamath et al.	7,809,438	B2	10/2010	Echt et al.
7,305,266	B1	12/2007	Kroll	7,840,281	B2	11/2010	Kveen et al.
7,310,556	B2	12/2007	Bulkes	7,844,331	B2	11/2010	Li et al.
7,319,905	B1	1/2008	Morgan et al.	7,844,348	B2	11/2010	Swoyer et al.
7,321,798	B2	1/2008	Muhlenberg et al.	7,846,088	B2	12/2010	Ness
7,333,853	B2	2/2008	Mazar et al.	7,848,815	B2	12/2010	Brisken et al.
7,336,994	B2	2/2008	Hettrick et al.	7,848,823	B2	12/2010	Drasler et al.
7,347,819	B2	3/2008	Lebel et al.	7,860,455	B2	12/2010	Fukumoto et al.
7,366,572	B2	4/2008	Heruth et al.	7,871,433	B2	1/2011	Lattouf
7,373,207	B2	5/2008	Lattouf	7,877,136	B1	1/2011	Moffitt et al.
7,384,403	B2	6/2008	Sherman	7,877,142	B2	1/2011	Moaddeb et al.
7,386,342	B1	6/2008	Falkenberg et al.	7,881,786	B2	2/2011	Jackson
7,392,090	B2	6/2008	Sweeney et al.	7,881,798	B2	2/2011	Miesel et al.
7,406,105	B2	7/2008	DelMain et al.	7,881,810	B1	2/2011	Chitre et al.
7,406,349	B2	7/2008	Seeberger et al.	7,890,173	B2	2/2011	Brisken et al.
7,410,497	B2	8/2008	Hastings et al.	7,890,181	B2	2/2011	Denzene et al.
7,425,200	B2	9/2008	Brockway et al.	7,890,192	B1	2/2011	Kelsch et al.
7,433,739	B1	10/2008	Salys et al.	7,894,885	B2	2/2011	Bartal et al.
7,496,409	B2	2/2009	Greenhut et al.	7,894,894	B2	2/2011	Stadler et al.
7,496,410	B2	2/2009	Heil	7,894,907	B2	2/2011	Cowan et al.
7,502,652	B2	3/2009	Gaunt et al.	7,894,910	B2	2/2011	Cowan et al.
7,512,448	B2	3/2009	Malick et al.	7,894,915	B1	2/2011	Chitre et al.
7,515,969	B2	4/2009	Tockman et al.	7,899,537	B1	3/2011	Kroll et al.
7,526,342	B2	4/2009	Chin et al.	7,899,541	B2	3/2011	Cowan et al.
7,529,589	B2	5/2009	Williams et al.	7,899,542	B2	3/2011	Cowan et al.
7,532,933	B2	5/2009	Hastings et al.	7,899,554	B2	3/2011	Williams et al.
7,536,222	B2	5/2009	Bardy et al.	7,901,360	B1	3/2011	Yang et al.
7,536,224	B2	5/2009	Ritscher et al.	7,904,170	B2	3/2011	Harding
7,539,541	B2	5/2009	Quiles et al.	7,907,993	B2	3/2011	Ghanem et al.
7,544,197	B2	6/2009	Kelsch et al.	7,920,928	B1	4/2011	Yang et al.
7,558,631	B2	7/2009	Cowan et al.	7,925,343	B1	4/2011	Min et al.
7,565,195	B1	7/2009	Kroll et al.	7,930,022	B2	4/2011	Zhang et al.
7,584,002	B2	9/2009	Burnes et al.	7,930,040	B1	4/2011	Kelsch et al.
7,590,455	B2	9/2009	Heruth et al.	7,937,135	B2	5/2011	Ghanem et al.
7,606,621	B2	10/2009	Brisken et al.	7,937,148	B2	5/2011	Jacobson
7,610,088	B2	10/2009	Chinchoy	7,937,161	B2	5/2011	Hastings et al.
7,610,092	B2	10/2009	Cowan et al.	7,941,214	B2	5/2011	Kleckner et al.
7,610,099	B2	10/2009	Almendinger et al.	7,945,333	B2	5/2011	Jacobson
7,610,104	B2	10/2009	Kaplan et al.	7,946,997	B2	5/2011	Hübinette
7,616,991	B2	11/2009	Mann et al.	7,949,404	B2	5/2011	Hill
7,617,001	B2	11/2009	Penner et al.	7,949,405	B2	5/2011	Fehér
7,617,007	B2	11/2009	Williams et al.	7,953,486	B2	5/2011	Daum et al.
7,630,767	B1	12/2009	Poore et al.	7,953,493	B2	5/2011	Fowler et al.
7,634,313	B1	12/2009	Kroll et al.	7,962,202	B2	6/2011	Bhunia
7,637,867	B2	12/2009	Zdeblick	7,974,702	B1	7/2011	Fain et al.
7,640,060	B2	12/2009	Zdeblick	7,979,136	B2	7/2011	Young et al.
7,647,109	B2	1/2010	Hastings et al.	7,983,753	B2	7/2011	Severin
7,650,186	B2	1/2010	Hastings et al.	7,991,467	B2	8/2011	Markowitz et al.
7,657,311	B2	2/2010	Bardy et al.	7,991,471	B2	8/2011	Ghanem et al.
7,668,596	B2	2/2010	Von Arx et al.	7,996,087	B2	8/2011	Cowan et al.
7,682,316	B2	3/2010	Anderson et al.	8,000,791	B2	8/2011	Sunagawa et al.
7,691,047	B2	4/2010	Ferrari	8,000,807	B2	8/2011	Morris et al.
7,702,392	B2	4/2010	Echt et al.	8,001,975	B2	8/2011	DiSilvestro et al.
				8,002,700	B2	8/2011	Ferek-Petric et al.
				8,010,209	B2	8/2011	Jacobson
				8,019,419	B1	9/2011	Panescu et al.
				8,019,434	B2	9/2011	Quiles et al.

(56)

References Cited

U.S. PATENT DOCUMENTS

8,027,727 B2	9/2011	Freeberg	8,406,879 B2	3/2013	Shuros et al.
8,027,729 B2	9/2011	Sunagawa et al.	8,406,886 B2	3/2013	Gaunt et al.
8,032,219 B2	10/2011	Neumann et al.	8,412,352 B2	4/2013	Griswold et al.
8,036,743 B2	10/2011	Savage et al.	8,417,340 B2	4/2013	Goossen
8,046,079 B2	10/2011	Bange et al.	8,417,341 B2	4/2013	Freeberg
8,046,080 B2	10/2011	Von Arx et al.	8,423,149 B2	4/2013	Hennig
8,050,297 B2	11/2011	DelMain et al.	8,428,722 B2	4/2013	Verhoef et al.
8,050,759 B2	11/2011	Stegemann et al.	8,433,402 B2	4/2013	Ruben et al.
8,050,774 B2	11/2011	Kveen et al.	8,433,409 B2	4/2013	Johnson et al.
8,055,345 B2	11/2011	Li et al.	8,433,420 B2	4/2013	Bange et al.
8,055,350 B2	11/2011	Roberts	8,447,412 B2	5/2013	Dal Molin et al.
8,060,212 B1	11/2011	Rios et al.	8,452,413 B2	5/2013	Young et al.
8,065,018 B2	11/2011	Haubrich et al.	8,457,740 B2	6/2013	Osche
8,073,542 B2	12/2011	Doerr	8,457,742 B2	6/2013	Jacobson
8,078,278 B2	12/2011	Penner	8,457,744 B2	6/2013	Janzig et al.
8,078,283 B2	12/2011	Cowan et al.	8,457,761 B2	6/2013	Wariar
8,095,123 B2	1/2012	Gray	8,478,407 B2	7/2013	Demmer et al.
8,102,789 B2	1/2012	Rosar et al.	8,478,408 B2	7/2013	Hastings et al.
8,103,359 B2	1/2012	Reddy	8,478,431 B2	7/2013	Griswold et al.
8,103,361 B2	1/2012	Moser	8,494,632 B2	7/2013	Sun et al.
8,112,148 B2	2/2012	Giftakis et al.	8,504,156 B2	8/2013	Bonner et al.
8,114,021 B2	2/2012	Robertson et al.	8,509,910 B2	8/2013	Sowder et al.
8,121,680 B2	2/2012	Falkenberg et al.	8,515,559 B2	8/2013	Roberts et al.
8,123,684 B2	2/2012	Zdeblick	8,525,340 B2	9/2013	Eckhardt et al.
8,126,545 B2	2/2012	Flach et al.	8,527,068 B2	9/2013	Ostroff
8,131,334 B2	3/2012	Lu et al.	8,532,790 B2	9/2013	Griswold
8,140,161 B2	3/2012	Willerton et al.	8,538,526 B2	9/2013	Stahmann et al.
8,150,521 B2	4/2012	Crowley et al.	8,541,131 B2	9/2013	Lund et al.
8,160,672 B2	4/2012	Kim et al.	8,543,205 B2	9/2013	Ostroff
8,160,702 B2	4/2012	Mann et al.	8,547,248 B2	10/2013	Zdeblick et al.
8,160,704 B2	4/2012	Freeberg	8,548,605 B2	10/2013	Ollivier
8,165,694 B2	4/2012	Carbanaru et al.	8,554,333 B2	10/2013	Wu et al.
8,175,715 B1	5/2012	Cox	8,565,882 B2	10/2013	Matos
8,180,451 B2	5/2012	Hickman et al.	8,565,897 B2	10/2013	Regnier et al.
8,185,213 B2	5/2012	Kveen et al.	8,571,678 B2	10/2013	Wang
8,187,161 B2	5/2012	Li et al.	8,577,327 B2	11/2013	Makdissi et al.
8,195,293 B2	6/2012	Limousin et al.	8,588,926 B2	11/2013	Moore et al.
8,204,595 B2	6/2012	Pianca et al.	8,612,002 B2	12/2013	Faltys et al.
8,204,605 B2	6/2012	Hastings et al.	8,615,310 B2	12/2013	Khairkhahan et al.
8,209,014 B2	6/2012	Doerr	8,626,280 B2	1/2014	Allavatam et al.
8,214,043 B2	7/2012	Matos	8,626,294 B2	1/2014	Sheldon et al.
8,224,244 B2	7/2012	Kim et al.	8,634,908 B2	1/2014	Cowan
8,229,556 B2	7/2012	Li	8,634,912 B2	1/2014	Bomzin et al.
8,233,985 B2	7/2012	Bulkes et al.	8,634,919 B1	1/2014	Hou et al.
8,262,578 B1	9/2012	Bharmi et al.	8,639,335 B2	1/2014	Peichel et al.
8,265,748 B2	9/2012	Liu et al.	8,644,934 B2	2/2014	Hastings et al.
8,265,757 B2	9/2012	Mass et al.	8,649,859 B2	2/2014	Smith et al.
8,280,521 B2	10/2012	Haubrich et al.	8,670,842 B1	3/2014	Bomzin et al.
8,285,387 B2	10/2012	Utsi et al.	8,676,319 B2	3/2014	Knoll
8,290,598 B2	10/2012	Boon et al.	8,676,335 B2	3/2014	Katoozi et al.
8,290,600 B2	10/2012	Hastings et al.	8,700,173 B2	4/2014	Edlund
8,295,939 B2	10/2012	Jacobson	8,700,181 B2	4/2014	Bomzin et al.
8,301,254 B2	10/2012	Mosesov et al.	8,705,599 B2	4/2014	dal Molin et al.
8,315,701 B2	11/2012	Cowan et al.	8,718,766 B2	5/2014	Wahlberg
8,315,708 B2	11/2012	Berthelsdorf et al.	8,718,773 B2	5/2014	Willis et al.
8,321,021 B2	11/2012	Kisker et al.	8,725,260 B2	5/2014	Shuros et al.
8,321,036 B2	11/2012	Brockway et al.	8,738,133 B2	5/2014	Shuros et al.
8,332,036 B2	12/2012	Hastings et al.	8,738,147 B2	5/2014	Hastings et al.
8,335,563 B2	12/2012	Stessman	8,744,555 B2	6/2014	Allavatam et al.
8,335,568 B2	12/2012	Heruth et al.	8,744,572 B1	6/2014	Greenhut et al.
8,340,750 B2	12/2012	Prakash et al.	8,747,314 B2	6/2014	Stahmann et al.
8,340,780 B2	12/2012	Hastings et al.	8,755,884 B2	6/2014	Demmer et al.
8,352,025 B2	1/2013	Jacobson	8,758,365 B2	6/2014	Bonner et al.
8,352,028 B2	1/2013	Wenger	8,768,483 B2	7/2014	Schmitt et al.
8,352,038 B2	1/2013	Mao et al.	8,774,572 B2	7/2014	Hamamoto
8,359,098 B2	1/2013	Lund et al.	8,781,605 B2	7/2014	Bornzin et al.
8,364,261 B2	1/2013	Stubbs et al.	8,788,035 B2	7/2014	Jacobson
8,364,276 B2	1/2013	Willis	8,788,053 B2	7/2014	Jacobson
8,369,959 B2	2/2013	Meskens	8,798,740 B2	8/2014	Samade et al.
8,369,962 B2	2/2013	Abrahamson	8,798,745 B2	8/2014	Jacobson
8,380,320 B2	2/2013	Spital	8,798,762 B2	8/2014	Fain et al.
8,386,051 B2	2/2013	Rys	8,798,770 B2	8/2014	Reddy
8,391,981 B2	3/2013	Mosesov	8,805,505 B1	8/2014	Roberts
8,391,990 B2	3/2013	Smith et al.	8,805,528 B2	8/2014	Corndorf
8,406,874 B2	3/2013	Liu et al.	8,812,109 B2	8/2014	Blomqvist et al.
			8,818,504 B2	8/2014	Bodner et al.
			8,827,913 B2	9/2014	Havel et al.
			8,831,747 B1	9/2014	Min et al.
			8,855,789 B2	10/2014	Jacobson

(56)

References Cited

U.S. PATENT DOCUMENTS

8,868,186	B2	10/2014	Kroll	9,526,522	B2	12/2016	Wood et al.
8,886,339	B2	11/2014	Faltys et al.	9,526,891	B2	12/2016	Eggen et al.
8,903,473	B2	12/2014	Rogers et al.	9,526,909	B2	12/2016	Stahmann et al.
8,903,500	B2	12/2014	Smith et al.	9,533,163	B2	1/2017	Klimovitch et al.
8,903,513	B2	12/2014	Ollivier	9,561,382	B2	2/2017	Persson et al.
8,909,336	B2	12/2014	Navarro-Paredes et al.	9,566,012	B2	2/2017	Greenhut et al.
8,914,131	B2	12/2014	Bomzin et al.	9,636,511	B2	5/2017	Carney et al.
8,923,795	B2	12/2014	Makdissi et al.	9,669,223	B2	6/2017	Auricchio et al.
8,923,963	B2	12/2014	Bonner et al.	9,687,654	B2	6/2017	Sheldon et al.
8,938,300	B2	1/2015	Rosero	9,687,655	B2	6/2017	Pertijs et al.
8,942,806	B2	1/2015	Sheldon et al.	9,687,659	B2	6/2017	Von Arx et al.
8,958,892	B2	2/2015	Khairkahan et al.	9,694,186	B2	7/2017	Carney et al.
8,977,358	B2	3/2015	Ewert et al.	9,782,594	B2	10/2017	Stahmann et al.
8,989,873	B2	3/2015	Locsin	9,782,601	B2	10/2017	Ludwig
8,996,109	B2	3/2015	Karst et al.	9,789,317	B2	10/2017	Greenhut et al.
9,002,467	B2	4/2015	Smith et al.	9,789,319	B2	10/2017	Sambelashvili
9,008,776	B2	4/2015	Cowan et al.	9,808,617	B2	11/2017	Ostroff et al.
9,008,777	B2	4/2015	Dianaty et al.	9,808,628	B2	11/2017	Sheldon et al.
9,014,818	B2	4/2015	Deterre et al.	9,808,631	B2	11/2017	Maile et al.
9,017,341	B2	4/2015	Bornzin et al.	9,808,632	B2	11/2017	Reinke et al.
9,020,611	B2	4/2015	Khairkahan et al.	9,808,633	B2	11/2017	Bonner et al.
9,037,262	B2	5/2015	Regnier et al.	9,808,637	B2	11/2017	Sharma et al.
9,042,984	B2	5/2015	Demmer et al.	9,855,414	B2	1/2018	Marshall et al.
9,072,911	B2	7/2015	Hastings et al.	9,855,430	B2	1/2018	Ghosh et al.
9,072,913	B2	7/2015	Jacobson	9,855,435	B2	1/2018	Sahabi et al.
9,155,882	B2	10/2015	Grubac et al.	9,861,815	B2	1/2018	Tran et al.
9,168,372	B2	10/2015	Fain	10,080,887	B2	9/2018	Schmidt et al.
9,168,380	B1	10/2015	Greenhut et al.	10,080,888	B2	9/2018	Kelly et al.
9,168,383	B2	10/2015	Jacobson et al.	10,080,900	B2	9/2018	Ghosh et al.
9,180,285	B2	11/2015	Moore et al.	10,080,903	B2	9/2018	Willis et al.
9,192,774	B2	11/2015	Jacobson	10,086,206	B2	10/2018	Sambelashvili
9,205,225	B2	12/2015	Khairkahan et al.	2002/0032470	A1	3/2002	Linberg
9,216,285	B1	12/2015	Boling et al.	2002/0035376	A1	3/2002	Bardy et al.
9,216,293	B2	12/2015	Berthiaume et al.	2002/0035377	A1	3/2002	Bardy et al.
9,216,298	B2	12/2015	Jacobson	2002/0035378	A1	3/2002	Bardy et al.
9,227,077	B2	1/2016	Jacobson	2002/0035380	A1	3/2002	Rissmann et al.
9,238,145	B2	1/2016	Wenzel et al.	2002/0035381	A1	3/2002	Bardy et al.
9,242,102	B2	1/2016	Khairkahan et al.	2002/0042629	A1	4/2002	Bardy et al.
9,242,113	B2	1/2016	Smith et al.	2002/0042630	A1	4/2002	Bardy et al.
9,248,300	B2	2/2016	Rys et al.	2002/0042634	A1	4/2002	Bardy et al.
9,265,436	B2	2/2016	Min et al.	2002/0049475	A1	4/2002	Bardy et al.
9,265,962	B2	2/2016	Dianaty et al.	2002/0052636	A1	5/2002	Bardy et al.
9,272,155	B2	3/2016	Ostroff	2002/0068958	A1	6/2002	Bardy et al.
9,278,218	B2	3/2016	Karst et al.	2002/0072773	A1	6/2002	Bardy et al.
9,278,229	B1	3/2016	Reinke et al.	2002/0082665	A1	6/2002	Haller et al.
9,283,381	B2	3/2016	Grubac et al.	2002/0091414	A1	7/2002	Bardy et al.
9,283,382	B2	3/2016	Berthiaume et al.	2002/0095196	A1	7/2002	Linberg
9,289,612	B1	3/2016	Sambelashvili et al.	2002/0099423	A1	7/2002	Berg et al.
9,302,115	B2	4/2016	Molin et al.	2002/0103510	A1	8/2002	Bardy et al.
9,333,364	B2	5/2016	Echt et al.	2002/0107545	A1	8/2002	Rissmann et al.
9,358,387	B2	6/2016	Suwito et al.	2002/0107546	A1	8/2002	Ostroff et al.
9,358,400	B2	6/2016	Jacobson	2002/0107547	A1	8/2002	Erlinger et al.
9,364,675	B2	6/2016	Deterre et al.	2002/0107548	A1	8/2002	Bardy et al.
9,370,663	B2	6/2016	Moulder	2002/0107549	A1	8/2002	Bardy et al.
9,375,580	B2	6/2016	Bonner et al.	2002/0107559	A1	8/2002	Sanders et al.
9,375,581	B2	6/2016	Baru et al.	2002/0120299	A1	8/2002	Ostroff et al.
9,381,365	B2	7/2016	Kibler et al.	2002/0173830	A1	11/2002	Starkweather et al.
9,393,424	B2	7/2016	Demmer et al.	2002/0193846	A1	12/2002	Pool et al.
9,393,436	B2	7/2016	Doerr	2003/0009203	A1	1/2003	Lebel et al.
9,399,139	B2	7/2016	Demmer et al.	2003/0028082	A1	2/2003	Thompson
9,399,140	B2	7/2016	Cho et al.	2003/0040779	A1	2/2003	Engmark et al.
9,409,033	B2	8/2016	Jacobson	2003/0041866	A1	3/2003	Linberg et al.
9,427,594	B1	8/2016	Bornzin et al.	2003/0045805	A1	3/2003	Sheldon et al.
9,433,368	B2	9/2016	Stahmann et al.	2003/0088278	A1	5/2003	Bardy et al.
9,433,780	B2	9/2016	Régnier et al.	2003/0097153	A1	5/2003	Bardy et al.
9,457,193	B2	10/2016	Klimovitch et al.	2003/0105497	A1	6/2003	Zhu et al.
9,492,668	B2	11/2016	Sheldon et al.	2003/0114908	A1	6/2003	Flach
9,492,669	B2	11/2016	Demmer et al.	2003/0144701	A1	7/2003	Mehra et al.
9,492,674	B2	11/2016	Schmidt et al.	2003/0187460	A1	10/2003	Chin et al.
9,492,677	B2	11/2016	Greenhut et al.	2003/0187461	A1	10/2003	Chin
9,511,233	B2	12/2016	Sambelashvili	2004/0024435	A1	2/2004	Leckrone et al.
9,511,236	B2	12/2016	Varady et al.	2004/0068302	A1	4/2004	Rodgers et al.
9,511,237	B2	12/2016	Deterre et al.	2004/0087938	A1	5/2004	Leckrone et al.
9,522,276	B2	12/2016	Shen et al.	2004/0088035	A1	5/2004	Guenst et al.
9,522,280	B2	12/2016	Fishler et al.	2004/0102830	A1	5/2004	Williams
				2004/0127959	A1	7/2004	Amundson et al.
				2004/0133242	A1	7/2004	Chapman et al.
				2004/0147969	A1	7/2004	Mann et al.
				2004/0147973	A1	7/2004	Hauser

(56)

References Cited

U.S. PATENT DOCUMENTS

2004/0167558	A1	8/2004	Igo et al.	2007/0293904	A1	12/2007	Gelbart et al.
2004/0167587	A1	8/2004	Thompson	2008/0004663	A1	1/2008	Jorgenson
2004/0172071	A1	9/2004	Bardy et al.	2008/0004664	A1	1/2008	Hopper et al.
2004/0172077	A1	9/2004	Chinchoy	2008/0021505	A1	1/2008	Hastings et al.
2004/0172104	A1	9/2004	Berg et al.	2008/0021519	A1	1/2008	De Geest et al.
2004/0176817	A1	9/2004	Wahlstrand et al.	2008/0021532	A1	1/2008	Kveen et al.
2004/0176818	A1	9/2004	Wahlstrand et al.	2008/0065183	A1	3/2008	Whitehurst et al.
2004/0176830	A1	9/2004	Fang	2008/0065185	A1	3/2008	Worley
2004/0186529	A1	9/2004	Bardy et al.	2008/0071318	A1	3/2008	Brooke et al.
2004/0204673	A1	10/2004	Flaherty	2008/0109054	A1	5/2008	Hastings et al.
2004/0210292	A1	10/2004	Bardy et al.	2008/0119911	A1	5/2008	Rosero
2004/0210293	A1	10/2004	Bardy et al.	2008/0130670	A1	6/2008	Kim et al.
2004/0210294	A1	10/2004	Bardy et al.	2008/0154139	A1	6/2008	Shuros et al.
2004/0215308	A1	10/2004	Bardy et al.	2008/0154322	A1	6/2008	Jackson et al.
2004/0220624	A1	11/2004	Ritscher et al.	2008/0228234	A1	9/2008	Stancer
2004/0220626	A1	11/2004	Wagner	2008/0234771	A1	9/2008	Chinchoy et al.
2004/0220639	A1	11/2004	Mulligan et al.	2008/0243217	A1	10/2008	Wildon
2004/0230283	A1	11/2004	Prinzen et al.	2008/0269814	A1	10/2008	Rosero
2004/0249431	A1	12/2004	Ransbury et al.	2008/0269825	A1	10/2008	Chinchoy et al.
2004/0260348	A1	12/2004	Bakken et al.	2008/0275518	A1	11/2008	Ghanem et al.
2004/0267303	A1	12/2004	Guenst	2008/0275519	A1	11/2008	Ghanem et al.
2005/0061320	A1	3/2005	Lee et al.	2008/0288039	A1	11/2008	Reddy
2005/0070962	A1	3/2005	Echt et al.	2008/0294208	A1	11/2008	Willis et al.
2005/0102003	A1	5/2005	Grabek et al.	2008/0294210	A1	11/2008	Rosero
2005/0149138	A1	7/2005	Min et al.	2008/0294229	A1	11/2008	Friedman et al.
2005/0165466	A1	7/2005	Morris et al.	2008/0306359	A1	12/2008	Zdeblick et al.
2005/0182465	A1	8/2005	Ness	2009/0018599	A1	1/2009	Hastings et al.
2005/0203410	A1	9/2005	Jenkins	2009/0024180	A1	1/2009	Kisker et al.
2005/0283208	A1	12/2005	Von Arx et al.	2009/0036941	A1	2/2009	Corbucci
2005/0288743	A1	12/2005	Ahn et al.	2009/0048646	A1	2/2009	Katoozi et al.
2006/0042830	A1	3/2006	Maghribi et al.	2009/0062895	A1	3/2009	Stahmann et al.
2006/0052829	A1	3/2006	Sun et al.	2009/0082827	A1	3/2009	Kveen et al.
2006/0052830	A1	3/2006	Spinelli et al.	2009/0082828	A1	3/2009	Ostroff
2006/0064135	A1	3/2006	Brockway	2009/0088813	A1	4/2009	Brockway et al.
2006/0064149	A1	3/2006	Belacazar et al.	2009/0131907	A1	5/2009	Chin et al.
2006/0085039	A1	4/2006	Hastings et al.	2009/0135886	A1	5/2009	Robertson et al.
2006/0085041	A1	4/2006	Hastings et al.	2009/0143835	A1	6/2009	Pastore et al.
2006/0085042	A1	4/2006	Hastings et al.	2009/0171408	A1	7/2009	Solem
2006/0095078	A1	5/2006	Tronnes	2009/0171414	A1	7/2009	Kelly et al.
2006/0106442	A1	5/2006	Richardson et al.	2009/0204163	A1	8/2009	Shuros et al.
2006/0116746	A1	6/2006	Chin	2009/0204170	A1	8/2009	Hastings et al.
2006/0135999	A1	6/2006	Bodner et al.	2009/0210024	A1	8/2009	M.
2006/0136004	A1	6/2006	Cowan et al.	2009/0216292	A1	8/2009	Pless et al.
2006/0161061	A1	7/2006	Echt et al.	2009/0234407	A1	9/2009	Hastings et al.
2006/0200002	A1	9/2006	Guenst	2009/0234411	A1	9/2009	Sambelashvili et al.
2006/0206151	A1	9/2006	Lu	2009/0266573	A1	10/2009	Engmark et al.
2006/0212079	A1	9/2006	Routh et al.	2009/0275998	A1	11/2009	Burnes et al.
2006/0241701	A1	10/2006	Markowitz et al.	2009/0275999	A1	11/2009	Burnes et al.
2006/0241705	A1	10/2006	Neumann et al.	2009/0299447	A1	12/2009	Jensen et al.
2006/0247672	A1	11/2006	Vidlund et al.	2010/0013668	A1	1/2010	Kantervik
2006/0259088	A1	11/2006	Pastore et al.	2010/0016911	A1	1/2010	Willis et al.
2006/0265018	A1	11/2006	Smith et al.	2010/0023085	A1	1/2010	Wu et al.
2007/0004979	A1	1/2007	Wojciechowicz et al.	2010/0030061	A1	2/2010	Canfield et al.
2007/0016098	A1	1/2007	Kim et al.	2010/0030327	A1	2/2010	Chatel
2007/0027508	A1	2/2007	Cowan	2010/0042108	A1	2/2010	Hibino
2007/0078490	A1	4/2007	Cowan et al.	2010/0056871	A1	3/2010	Govari et al.
2007/0088394	A1	4/2007	Jacobson	2010/0063375	A1	3/2010	Kassab et al.
2007/0088396	A1	4/2007	Jacobson	2010/0063562	A1	3/2010	Cowan et al.
2007/0088397	A1	4/2007	Jacobson	2010/0069983	A1	3/2010	Peacock, III et al.
2007/0088398	A1	4/2007	Jacobson	2010/0094367	A1	4/2010	Sen
2007/0088405	A1	4/2007	Jacobson	2010/0114209	A1	5/2010	Krause et al.
2007/0135882	A1	6/2007	Drasler et al.	2010/0114214	A1	5/2010	Morelli et al.
2007/0135883	A1	6/2007	Drasler et al.	2010/0125281	A1	5/2010	Jacobson et al.
2007/0142864	A1	6/2007	Libbus et al.	2010/0168761	A1	7/2010	Kassab et al.
2007/0150037	A1	6/2007	Hastings et al.	2010/0168819	A1	7/2010	Freeberg
2007/0150038	A1	6/2007	Hastings et al.	2010/0198288	A1	8/2010	Ostroff
2007/0156190	A1	7/2007	Cinbis	2010/0198304	A1	8/2010	Wang
2007/0219525	A1	9/2007	Gelfand et al.	2010/0217367	A1	8/2010	Belson
2007/0219590	A1	9/2007	Hastings et al.	2010/0228308	A1	9/2010	Cowan et al.
2007/0225545	A1	9/2007	Ferrari	2010/0234906	A1	9/2010	Koh
2007/0233206	A1	10/2007	Frikart et al.	2010/0234924	A1	9/2010	Willis
2007/0239244	A1	10/2007	Morgan et al.	2010/0241185	A1	9/2010	Mahapatra et al.
2007/0255376	A1	11/2007	Michels et al.	2010/0249729	A1	9/2010	Morris et al.
2007/0276444	A1	11/2007	Gelbart et al.	2010/0286744	A1	11/2010	Echt et al.
2007/0293900	A1	12/2007	Sheldon et al.	2010/0298841	A1	11/2010	Prinzen et al.
				2010/0312309	A1	12/2010	Harding
				2011/0022113	A1	1/2011	Zdeblick et al.
				2011/0071586	A1	3/2011	Jacobson
				2011/0077708	A1	3/2011	Ostroff

(56)

References Cited

U.S. PATENT DOCUMENTS

2011/0112600	A1	5/2011	Cowan et al.	2013/0060298	A1	3/2013	Splett et al.
2011/0118588	A1	5/2011	Komblau et al.	2013/0066169	A1	3/2013	Rys et al.
2011/0118810	A1	5/2011	Cowan et al.	2013/0072770	A1	3/2013	Rao et al.
2011/0137187	A1	6/2011	Yang et al.	2013/0079798	A1	3/2013	Tran et al.
2011/0144720	A1	6/2011	Cowan et al.	2013/0079861	A1	3/2013	Reinert et al.
2011/0152970	A1	6/2011	Jollota et al.	2013/0085350	A1	4/2013	Schugt et al.
2011/0160558	A1	6/2011	Rassaff et al.	2013/0085403	A1	4/2013	Gunderson et al.
2011/0160565	A1	6/2011	Stubbs et al.	2013/0085550	A1	4/2013	Polefko et al.
2011/0160801	A1	6/2011	Markowitz et al.	2013/0096649	A1	4/2013	Martin et al.
2011/0160806	A1	6/2011	Lyden et al.	2013/0103047	A1	4/2013	Steingisser et al.
2011/0166620	A1	7/2011	Cowan et al.	2013/0103109	A1	4/2013	Jacobson
2011/0166621	A1	7/2011	Cowan et al.	2013/0110008	A1	5/2013	Bourget et al.
2011/0184491	A1	7/2011	Kivi	2013/0110127	A1	5/2013	Bornzin et al.
2011/0190835	A1	8/2011	Brockway et al.	2013/0110192	A1	5/2013	Tran et al.
2011/0208260	A1	8/2011	Jacobson	2013/0110219	A1	5/2013	Bornzin et al.
2011/0218587	A1	9/2011	Jacobson	2013/0116529	A1	5/2013	Min et al.
2011/0230734	A1	9/2011	Fain et al.	2013/0116738	A1	5/2013	Samade et al.
2011/0237967	A1	9/2011	Moore et al.	2013/0116740	A1	5/2013	Bornzin et al.
2011/0245890	A1	10/2011	Brisben et al.	2013/0116741	A1	5/2013	Bornzin et al.
2011/0251660	A1	10/2011	Griswold	2013/0123872	A1	5/2013	Bornzin et al.
2011/0251662	A1	10/2011	Griswold et al.	2013/0123875	A1	5/2013	Varady et al.
2011/0270099	A1	11/2011	Ruben et al.	2013/0131591	A1	5/2013	Berthiaume et al.
2011/0270339	A1	11/2011	Murray, III et al.	2013/0131693	A1	5/2013	Berthiaume et al.
2011/0270340	A1	11/2011	Pellegrini et al.	2013/0138006	A1	5/2013	Bornzin et al.
2011/0270341	A1	11/2011	Ruben et al.	2013/0150695	A1	6/2013	Biela et al.
2011/0276102	A1	11/2011	Cohen	2013/0150911	A1	6/2013	Perscbacher et al.
2011/0282423	A1	11/2011	Jacobson	2013/0150912	A1	6/2013	Perscbacher et al.
2012/0004527	A1	1/2012	Thompson et al.	2013/0184776	A1	7/2013	Shuros et al.
2012/0029323	A1	2/2012	Zhao	2013/0192611	A1	8/2013	Taepke, II et al.
2012/0041508	A1	2/2012	Rouso et al.	2013/0196703	A1	8/2013	Masoud et al.
2012/0059433	A1	3/2012	Cowan et al.	2013/0197609	A1	8/2013	Moore et al.
2012/0059436	A1	3/2012	Fontaine et al.	2013/0231710	A1	9/2013	Jacobson
2012/0065500	A1	3/2012	Rogers et al.	2013/0238072	A1	9/2013	Deterre et al.
2012/0078322	A1	3/2012	Dal Molin et al.	2013/0238073	A1	9/2013	Makdissi et al.
2012/0089198	A1	4/2012	Ostroff	2013/0253309	A1	9/2013	Allan et al.
2012/0093245	A1	4/2012	Makdissi et al.	2013/0253342	A1	9/2013	Griswold et al.
2012/0095521	A1	4/2012	Hintz	2013/0253343	A1	9/2013	Waldhauser et al.
2012/0095539	A1	4/2012	Khairkhan et al.	2013/0253344	A1	9/2013	Griswold et al.
2012/0101540	A1	4/2012	O'Brien et al.	2013/0253345	A1	9/2013	Griswold et al.
2012/0101553	A1	4/2012	Reddy	2013/0253346	A1	9/2013	Griswold et al.
2012/0109148	A1	5/2012	Bonner et al.	2013/0253347	A1	9/2013	Griswold et al.
2012/0109149	A1	5/2012	Bonner et al.	2013/0261497	A1	10/2013	Pertjjs et al.
2012/0109236	A1	5/2012	Jacobson et al.	2013/0265144	A1	10/2013	Banna et al.
2012/0109259	A1	5/2012	Bond et al.	2013/0268042	A1	10/2013	Hastings et al.
2012/0116489	A1	5/2012	Khairkhan et al.	2013/0274828	A1	10/2013	Willis
2012/0150251	A1	6/2012	Giftakis et al.	2013/0274847	A1	10/2013	Ostroff
2012/0158111	A1	6/2012	Khairkhan et al.	2013/0282070	A1	10/2013	Cowan et al.
2012/0165827	A1	6/2012	Khairkhan et al.	2013/0282073	A1	10/2013	Cowan et al.
2012/0172690	A1	7/2012	Anderson et al.	2013/0296727	A1	11/2013	Sullivan et al.
2012/0172891	A1	7/2012	Lee	2013/0303872	A1	11/2013	Taff et al.
2012/0172892	A1	7/2012	Grubac et al.	2013/0324825	A1	12/2013	Ostroff et al.
2012/0172942	A1	7/2012	Berg	2013/0325081	A1	12/2013	Karst et al.
2012/0197350	A1	8/2012	Roberts et al.	2013/0345770	A1	12/2013	Dianaty et al.
2012/0197373	A1	8/2012	Khairkhan et al.	2014/0012344	A1	1/2014	Hastings et al.
2012/0215285	A1	8/2012	Tahmasian et al.	2014/0018876	A1	1/2014	Ostroff
2012/0232565	A1	9/2012	Kveen et al.	2014/0018877	A1	1/2014	Demmer et al.
2012/0245665	A1	9/2012	Friedman et al.	2014/0031836	A1	1/2014	Ollivier
2012/0277600	A1	11/2012	Greenhut	2014/0039570	A1	2/2014	Carroll et al.
2012/0277606	A1	11/2012	Ellingson et al.	2014/0039591	A1	2/2014	Drasler et al.
2012/0283795	A1	11/2012	Stancer et al.	2014/0043146	A1	2/2014	Makdissi et al.
2012/0283807	A1	11/2012	Deterre et al.	2014/0046395	A1	2/2014	Regnier et al.
2012/0289776	A1	11/2012	Keast et al.	2014/0046420	A1	2/2014	Moore et al.
2012/0289815	A1	11/2012	Keast et al.	2014/0058240	A1	2/2014	Mothilal et al.
2012/0290021	A1	11/2012	Saurkar et al.	2014/0058494	A1	2/2014	Ostroff et al.
2012/0290025	A1	11/2012	Keimel	2014/0074114	A1	3/2014	Khairkhan et al.
2012/0296381	A1	11/2012	Matos	2014/0074186	A1	3/2014	Faltys et al.
2012/0303082	A1	11/2012	Dong et al.	2014/0094891	A1	4/2014	Pare et al.
2012/0316613	A1	12/2012	Keefe et al.	2014/0100624	A1	4/2014	Ellingson
2013/0012151	A1	1/2013	Hankins	2014/0100627	A1	4/2014	Min
2013/0023975	A1	1/2013	Locsin	2014/0107723	A1	4/2014	Hou et al.
2013/0035748	A1	2/2013	Bonner et al.	2014/0121719	A1	5/2014	Bonner et al.
2013/0041422	A1	2/2013	Jacobson	2014/0121720	A1	5/2014	Bonner et al.
2013/0053908	A1	2/2013	Smith et al.	2014/0121722	A1	5/2014	Sheldon et al.
2013/0053915	A1	2/2013	Holmstrom et al.	2014/0128935	A1	5/2014	Kumar et al.
2013/0053921	A1	2/2013	Bonner et al.	2014/0135865	A1	5/2014	Hastings et al.
				2014/0142648	A1	5/2014	Smith et al.
				2014/0148675	A1	5/2014	Nordstrom et al.
				2014/0148815	A1	5/2014	Wenzel et al.
				2014/0155950	A1	6/2014	Hastings et al.

(56)

References Cited

U.S. PATENT DOCUMENTS

2014/0169162 A1 6/2014 Romano et al.
 2014/0172060 A1 6/2014 Bornzin et al.
 2014/0180306 A1 6/2014 Grubac et al.
 2014/0180366 A1 6/2014 Edlund
 2014/0207149 A1 7/2014 Hastings et al.
 2014/0207210 A1 7/2014 Willis et al.
 2014/0214104 A1 7/2014 Greenhut et al.
 2014/0222015 A1 8/2014 Keast et al.
 2014/0222098 A1 8/2014 Baru et al.
 2014/0222109 A1 8/2014 Moulder
 2014/0228913 A1 8/2014 Molin et al.
 2014/0236172 A1 8/2014 Hastings et al.
 2014/0243848 A1 8/2014 Auricchio et al.
 2014/0255298 A1 9/2014 Cole et al.
 2014/0257324 A1 9/2014 Fain
 2014/0257422 A1 9/2014 Herken
 2014/0257444 A1 9/2014 Cole et al.
 2014/0276929 A1 9/2014 Foster et al.
 2014/0303704 A1 10/2014 Suwito et al.
 2014/0309706 A1 10/2014 Jacobson
 2014/0343348 A1 11/2014 Kaplan et al.
 2014/0371818 A1 12/2014 Bond et al.
 2014/0379041 A1 12/2014 Foster
 2015/0025612 A1 1/2015 Haasl et al.
 2015/0039041 A1 2/2015 Smith et al.
 2015/0045868 A1 2/2015 Bonner et al.
 2015/0051609 A1 2/2015 Schmidt et al.
 2015/0051610 A1 2/2015 Schmidt et al.
 2015/0051611 A1 2/2015 Schmidt et al.
 2015/0051612 A1 2/2015 Schmidt et al.
 2015/0051613 A1 2/2015 Schmidt et al.
 2015/0051614 A1 2/2015 Schmidt et al.
 2015/0051615 A1 2/2015 Schmidt et al.
 2015/0051616 A1 2/2015 Haasl et al.
 2015/0051682 A1 2/2015 Schmidt et al.
 2015/0057520 A1 2/2015 Foster et al.
 2015/0057558 A1 2/2015 Stahmann et al.
 2015/0057721 A1 2/2015 Stahmann et al.
 2015/0088155 A1 3/2015 Stahmann et al.
 2015/0105836 A1 4/2015 Bonner et al.
 2015/0126854 A1 5/2015 Keast et al.
 2015/0157861 A1 6/2015 Aghassian
 2015/0157866 A1 6/2015 Demmer et al.
 2015/0173655 A1 6/2015 Demmer et al.
 2015/0190638 A1 7/2015 Smith et al.
 2015/0196756 A1 7/2015 Stahmann et al.
 2015/0196757 A1 7/2015 Stahmann et al.
 2015/0196758 A1 7/2015 Stahmann et al.
 2015/0196769 A1 7/2015 Stahmann et al.
 2015/0217119 A1 8/2015 Nikolski et al.
 2015/0221898 A1 8/2015 Chi et al.
 2015/0224315 A1 8/2015 Stahmann
 2015/0224320 A1 8/2015 Stahmann
 2015/0230699 A1 8/2015 Berul et al.
 2015/0238769 A1 8/2015 Demmer et al.
 2015/0258345 A1 9/2015 Smith et al.
 2015/0290468 A1 10/2015 Zhang
 2015/0297905 A1 10/2015 Greenhut et al.
 2015/0297907 A1 10/2015 Zhang
 2015/0305637 A1 10/2015 Greenhut et al.
 2015/0305638 A1 10/2015 Zhang
 2015/0305639 A1 10/2015 Greenhut et al.
 2015/0305640 A1 10/2015 Reinke et al.
 2015/0305641 A1 10/2015 Stadler et al.
 2015/0305642 A1 10/2015 Reinke et al.
 2015/0306374 A1 10/2015 Seifert et al.
 2015/0306375 A1 10/2015 Marshall et al.
 2015/0306401 A1 10/2015 Demmer et al.
 2015/0306406 A1 10/2015 Crutchfield et al.
 2015/0306407 A1 10/2015 Crutchfield et al.
 2015/0306408 A1 10/2015 Greenhut et al.
 2015/0321016 A1 11/2015 O'Brien et al.
 2015/0328459 A1 11/2015 Chin et al.
 2015/0335884 A1 11/2015 Khairkahan et al.
 2015/0360036 A1 12/2015 Kane et al.

2016/0015322 A1 1/2016 Anderson et al.
 2016/0023000 A1 1/2016 Cho et al.
 2016/0030757 A1 2/2016 Jacobson
 2016/0033177 A1 2/2016 Barot et al.
 2016/0121127 A1 5/2016 Klimovitch et al.
 2016/0121128 A1 5/2016 Fishler et al.
 2016/0121129 A1 5/2016 Persson et al.
 2016/0213919 A1 7/2016 Suwito et al.
 2016/0213937 A1 7/2016 Reinke et al.
 2016/0213939 A1 7/2016 Carney et al.
 2016/0228026 A1 8/2016 Jackson
 2016/0250480 A1 9/2016 Sheldon et al.
 2016/0317825 A1 11/2016 Jacobson
 2016/0367823 A1 12/2016 Cowan et al.
 2017/0014629 A1 1/2017 Ghosh et al.
 2017/0035315 A1 2/2017 Jackson
 2017/0043173 A1 2/2017 Sharma et al.
 2017/0043174 A1 2/2017 Greenhut et al.
 2017/0189681 A1 7/2017 Anderson
 2017/0281261 A1 10/2017 Shuros et al.
 2017/0281952 A1 10/2017 Shuros et al.
 2017/0281953 A1 10/2017 Min et al.
 2017/0281955 A1 10/2017 Maile et al.
 2017/0312531 A1 11/2017 Sawchuk
 2018/0117339 A1* 5/2018 Huelskamp A61N 1/37512
 2018/0256902 A1 9/2018 Toy et al.
 2018/0256909 A1 9/2018 Smith et al.
 2018/0264262 A1 9/2018 Haasl et al.
 2018/0264270 A1 9/2018 Koop et al.
 2018/0264272 A1 9/2018 Haasl et al.
 2018/0264273 A1 9/2018 Haasl et al.
 2018/0264274 A1 9/2018 Haasl et al.

FOREIGN PATENT DOCUMENTS

AU 2014203793 A1 7/2014
 CA 1003904 A1 1/1977
 CN 202933393 U 5/2013
 EP 0362611 A1 4/1990
 EP 503823 A2 9/1992
 EP 1702648 A2 9/2006
 EP 1904166 B1 6/2011
 EP 2471452 A1 7/2012
 EP 2433675 B1 1/2013
 EP 2441491 B1 1/2013
 EP 2452721 B1 11/2013
 EP 2662113 A3 11/2013
 EP 1948296 B1 1/2014
 EP 2760541 B1 5/2016
 EP 2833966 B1 5/2016
 JP 2000051373 A 2/2000
 JP 2002502640 A 1/2002
 JP 2004512105 A 4/2004
 JP 2005508208 A 3/2005
 JP 2005245215 A 9/2005
 JP 2008540040 A 11/2008
 JP 5199867 B2 2/2013
 WO 9500202 A1 1/1995
 WO 9636134 A1 11/1996
 WO 9724981 A2 7/1997
 WO 9826840 A1 6/1998
 WO 9939767 A1 8/1999
 WO 0234330 A2 5/2002
 WO 02098282 A2 12/2002
 WO 2005000206 A3 1/2005
 WO 2005042089 A1 5/2005
 WO 2006065394 A1 6/2006
 WO 2006086435 A3 8/2006
 WO 2006113659 A1 10/2006
 WO 2006124833 A3 11/2006
 WO 2007073435 A1 6/2007
 WO 2007075974 A2 7/2007
 WO 2009006531 A1 1/2009
 WO 2012054102 A1 4/2012
 WO 2013080038 A2 6/2013
 WO 2013098644 A3 7/2013

(56) **References Cited**

FOREIGN PATENT DOCUMENTS

WO 2013184787 A1 12/2013
WO 2014120769 A1 8/2014

OTHER PUBLICATIONS

International Search Report and Written Opinion for Application No. PCT/US2017/059048, 32 pages, dated Feb. 8, 2018.

“Instructions for Use System 1, Leadless Cardiac Pacemaker (LCP) and Delivery Catheter,” Nanostim Leadless Pacemakers, pp. 1-28, 2013.

Hachisuka et al., “Development and Performance Analysis of an Intra-Body Communication Device,” The 12th International Conference on Solid State Sensors, Actuators and Microsystems, vol. 4A1.3, pp. 1722-1725, 2003.

Seyedi et al., “A Survey on Intra-body Communications for Body Area Network Application,” IEEE Transactions on Biomedical Engineering, vol. 60(8): 2067-2079, 2013.

Spickler et al., “Totally Self-Contained Intracardiac Pacemaker,” Journal of Electrocardiology, vol. 3(3&4): 324-331, 1970.

Wegmüller, “Intra-Body Communication for Biomedical Sensor Networks,” Diss. ETH, No. 17323, 1-173, 2007.

* cited by examiner

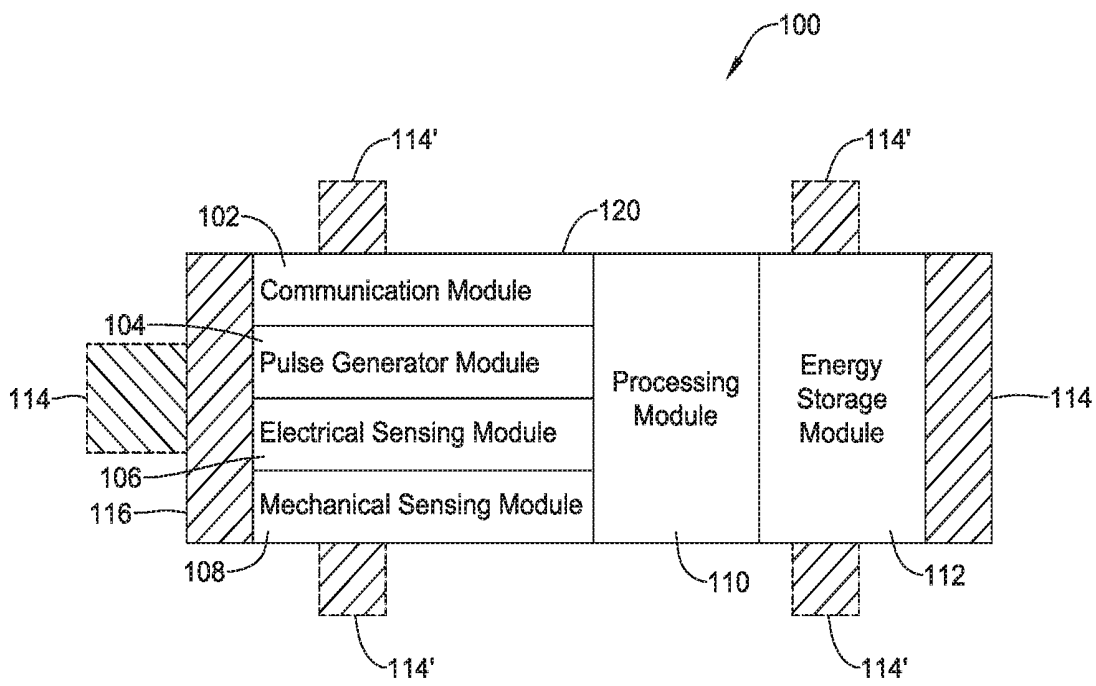

Figure 1

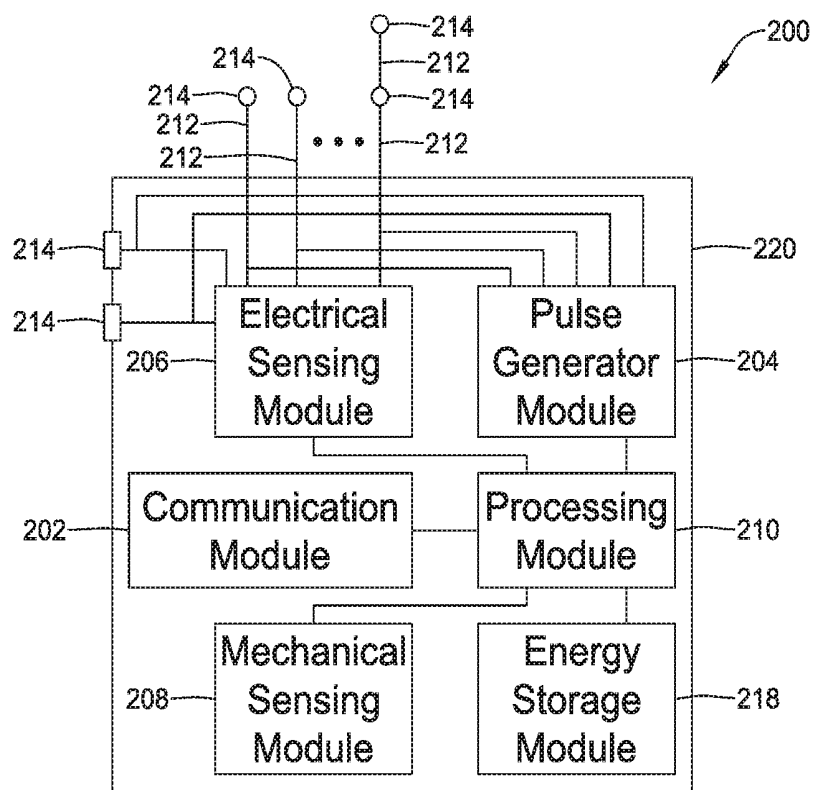

Figure 2

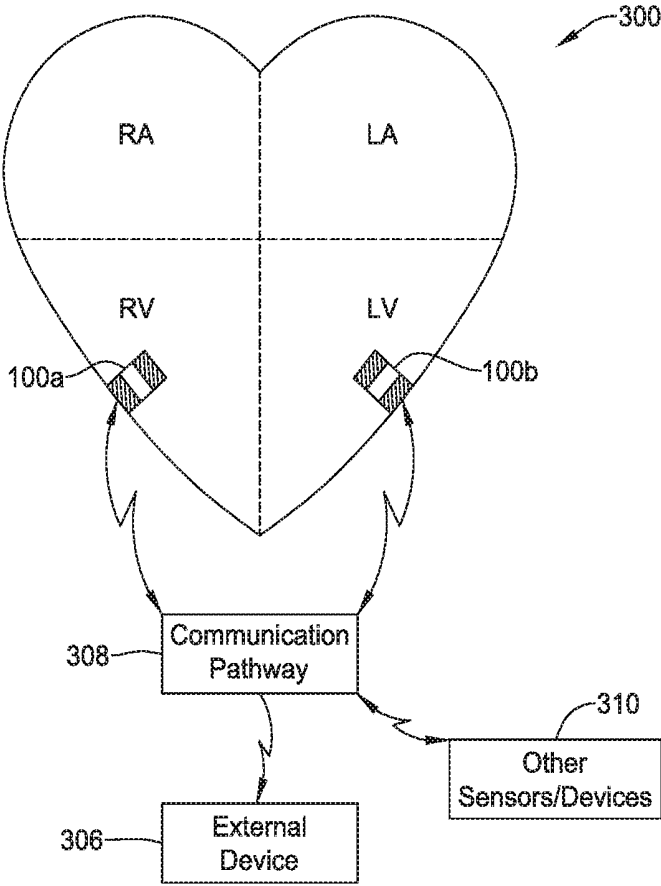

Figure 3

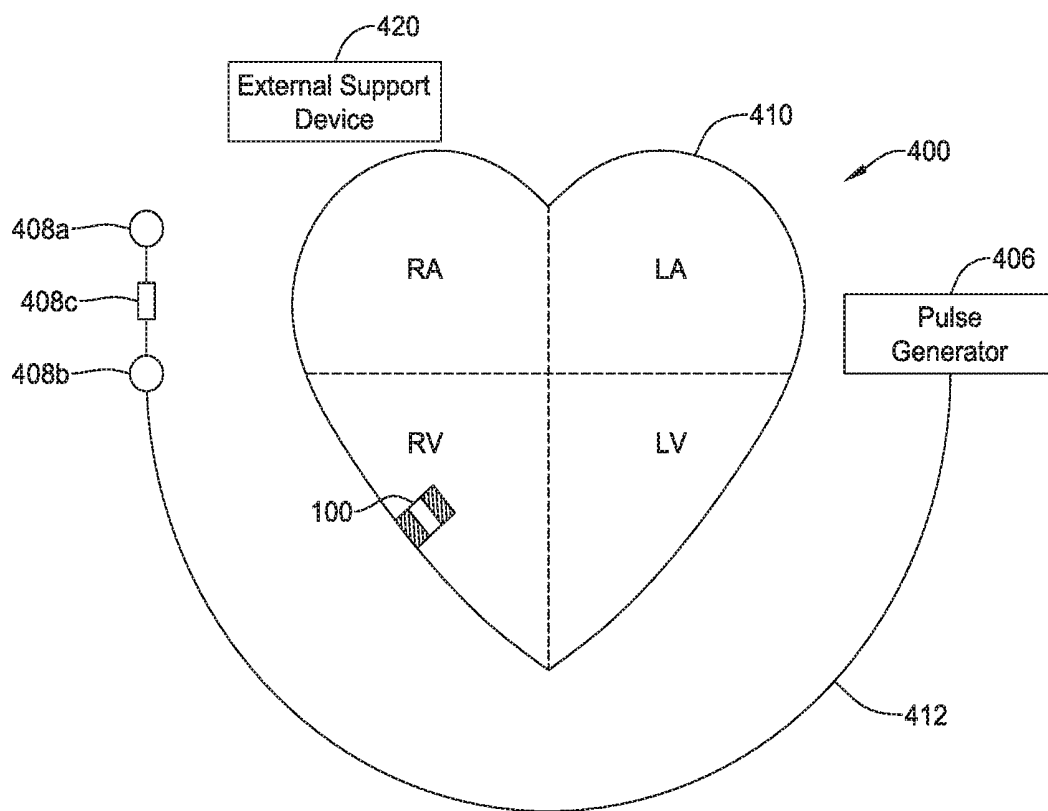

Figure 4

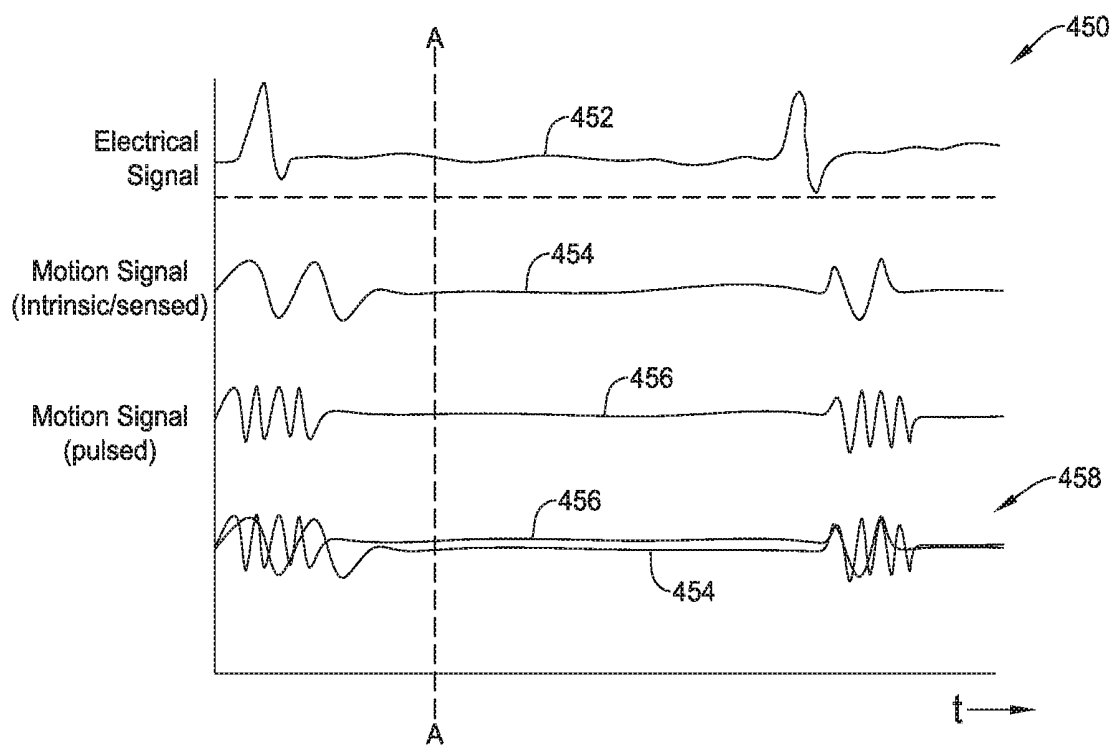

FIG. 5

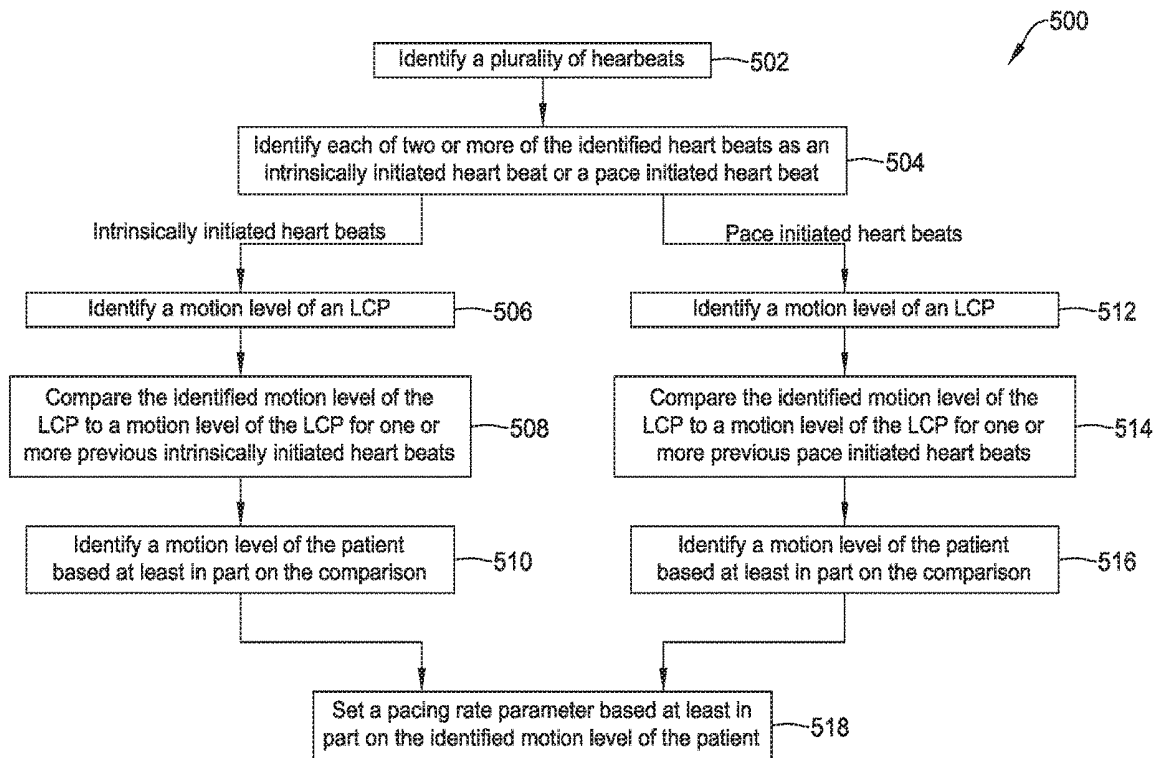

FIG. 6

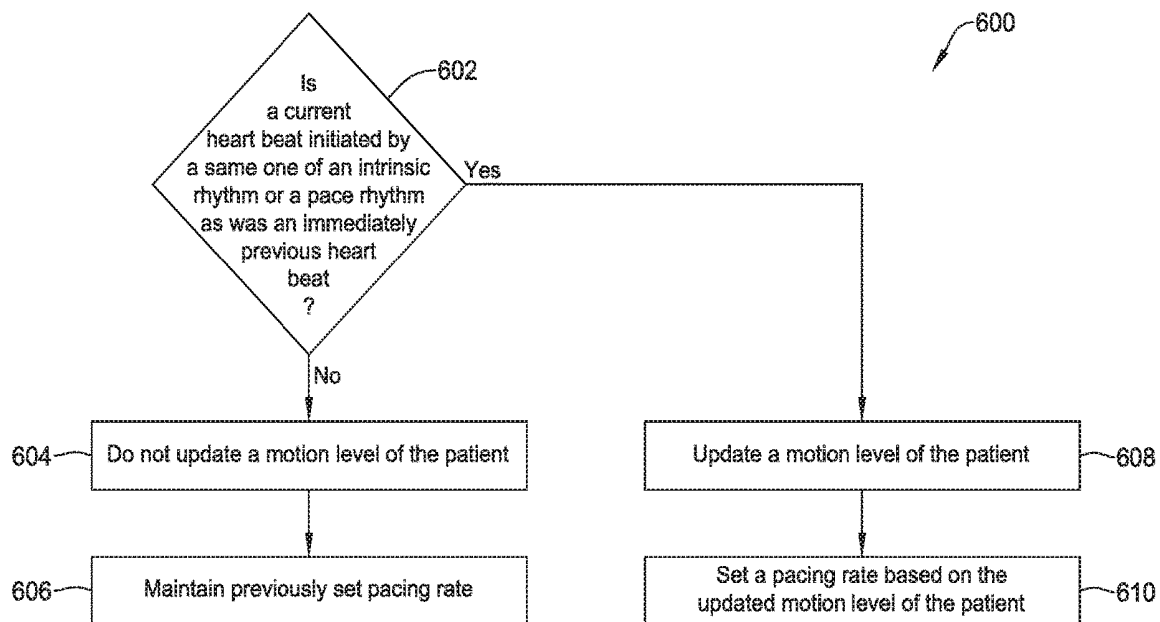

FIG. 7

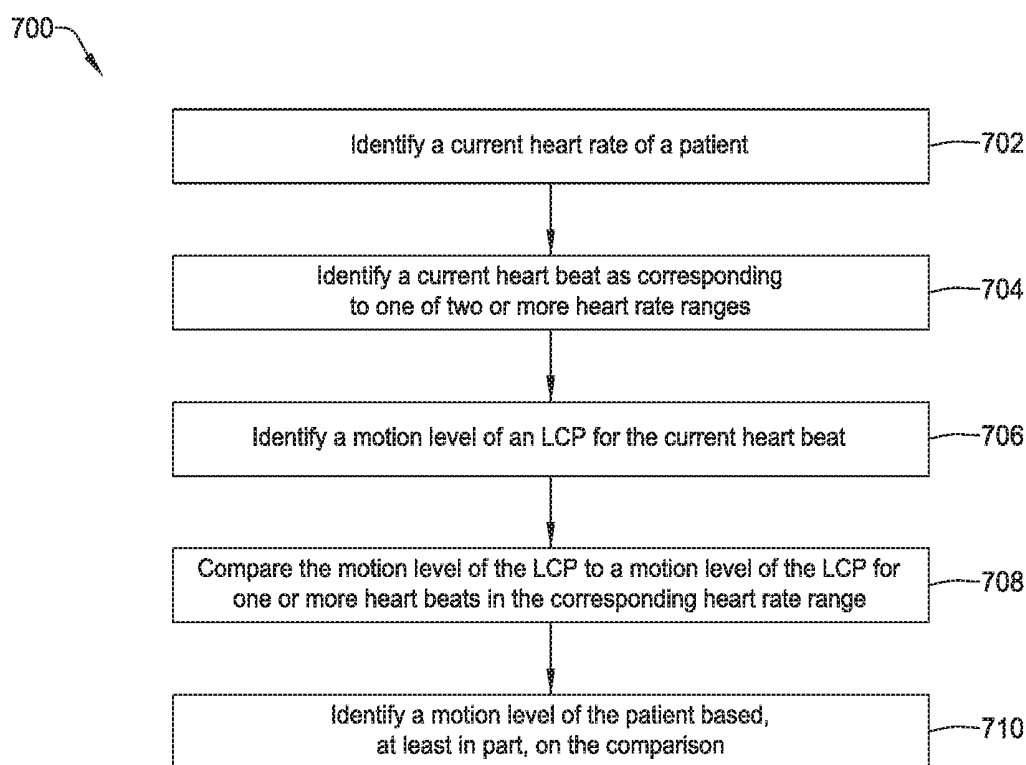

FIG. 8

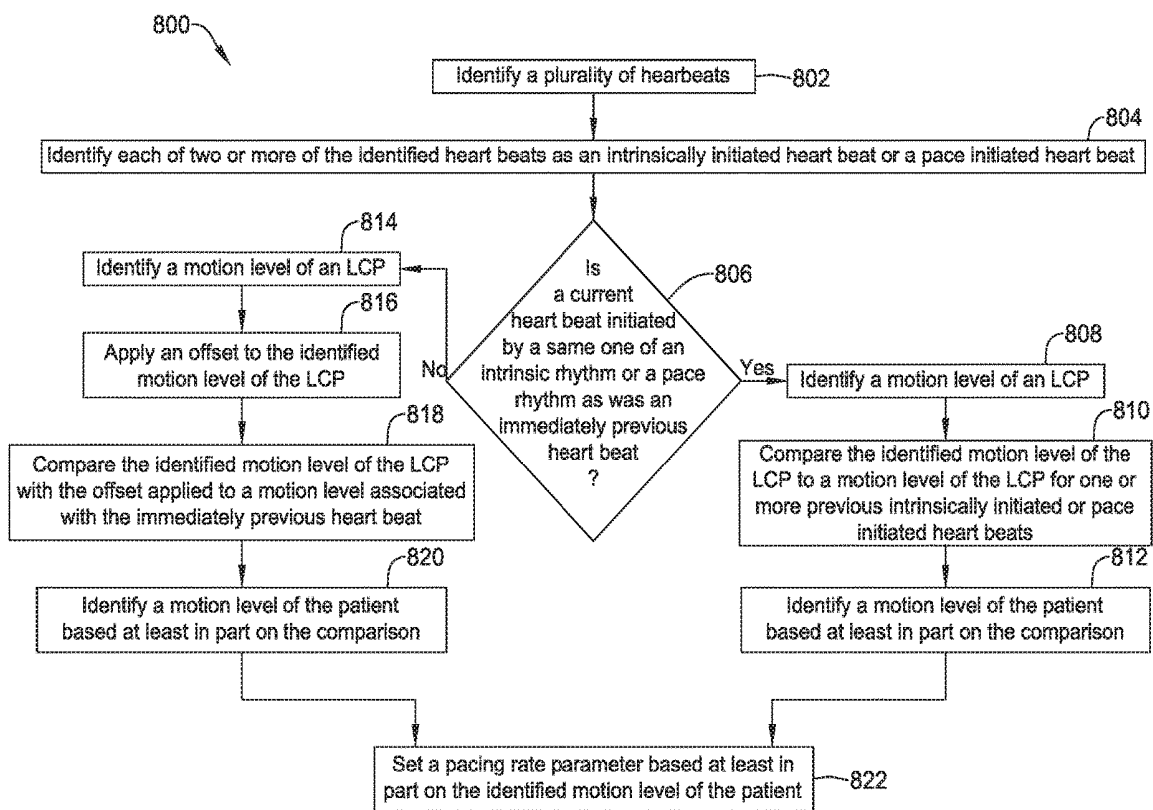

FIG. 9

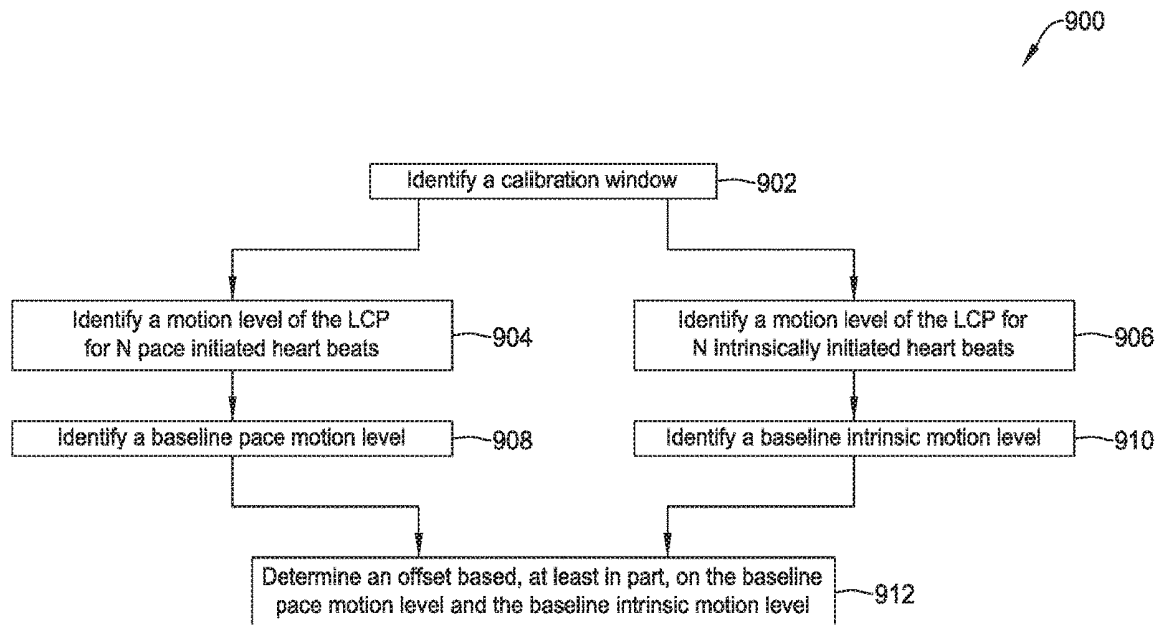

FIG. 10

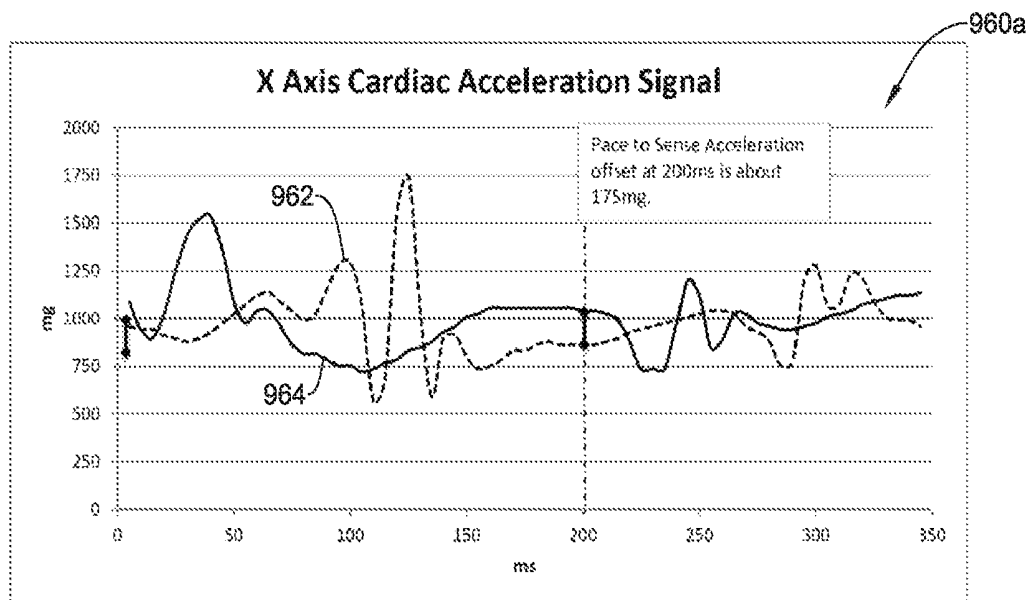

FIG. 11A

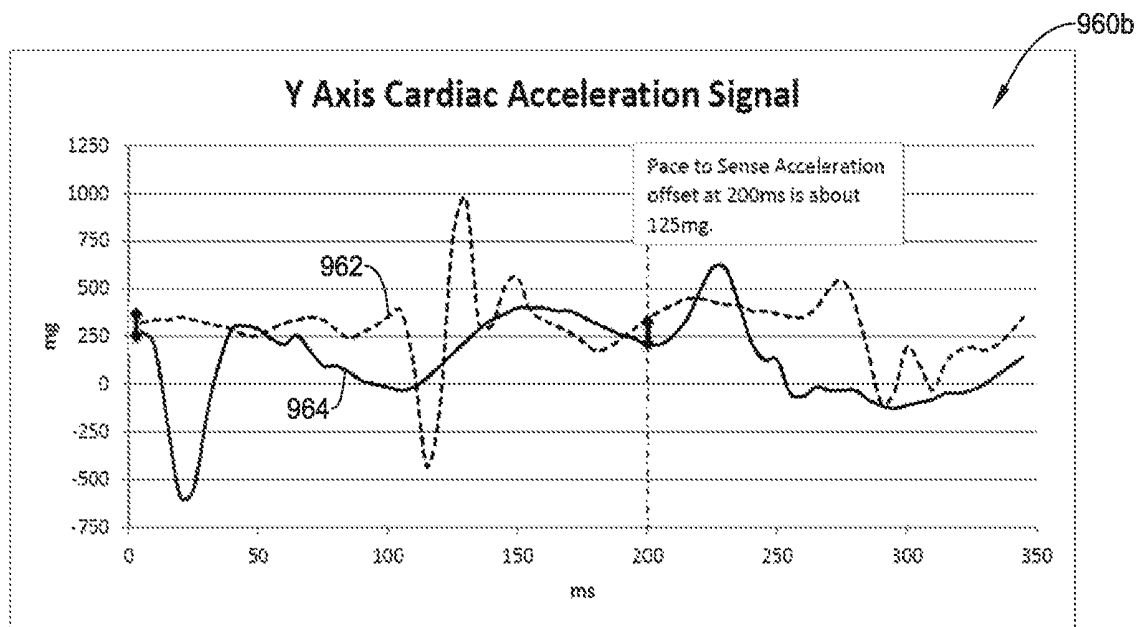

FIG. 11B

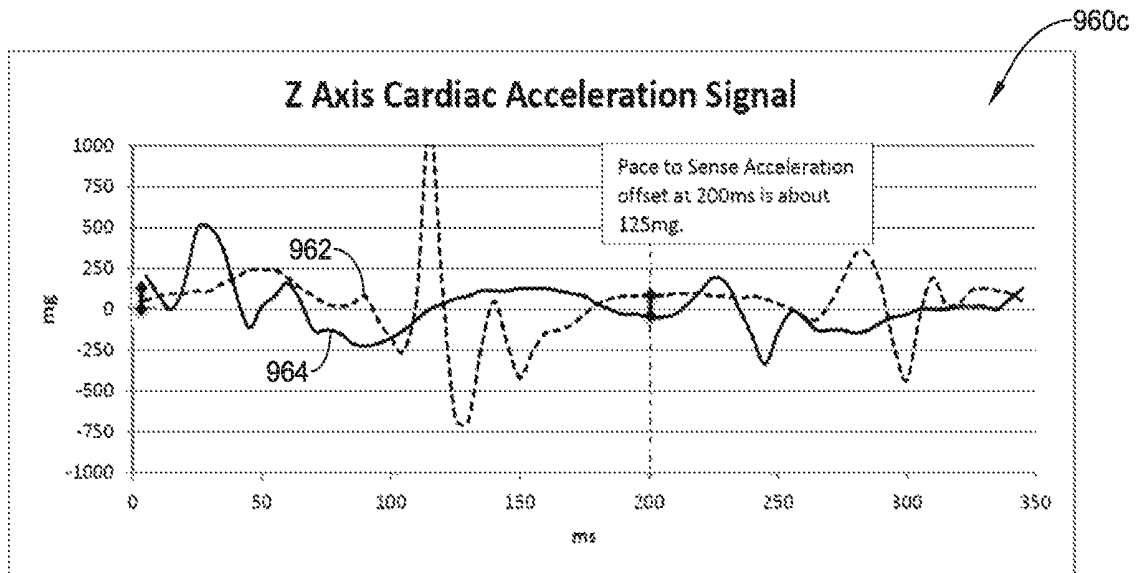

FIG. 11C

SYSTEMS AND METHODS FOR ACTIVITY LEVEL PACING

CROSS REFERENCE TO RELATED APPLICATIONS

This application claims the benefit of U.S. Provisional Patent Application Ser. No. 62/424,876 filed on Nov. 21, 2016, and U.S. Provisional Patent Application Ser. No. 62/415,132 filed on Oct. 31, 2016, the disclosures of which are incorporated herein by reference.

The present disclosure generally relates to systems, devices, and methods for delivering pacing therapy to a patient, and more particularly, to systems, devices, and methods for modulating pacing therapy based on an activity level of the patient.

BACKGROUND

Pacing instruments can be used to treat patients suffering from various heart conditions that result in a reduced ability of the heart to deliver sufficient amounts of blood to a patient's body. These heart conditions may lead to rapid, irregular, and/or inefficient heart contractions. To help alleviate some of these conditions, various devices (e.g., pacemakers, defibrillators, etc.) can be implanted in a patient's body. Such devices may monitor and provide electrical stimulation to the heart to help the heart operate in a more normal, efficient and/or safe manner. In some cases, such devices may modulate delivered pacing therapy based on a patient's activity level, which is sometime referred to as rate responsive pacing.

SUMMARY

The present disclosure generally relates to systems, devices, and methods for delivering pacing therapy to a patient, and more particularly, to systems, devices, and methods for modulating pacing therapy based on an activity level of the patient.

In an illustrative embodiment, an implantable medical device (IMD) implantable within a patient's may comprise two or more sensors including a motion sensor and a controller operatively coupled to the two or more sensors. The controller may identify a plurality of heart beats using one or more of the sensors, each of the plurality of heart beats having a systole phase and diastole phase. The controller may identify each of two or more of the plurality of heart beats as an intrinsically initiated heart beat or a pace initiated heart beat, and identify a calibration time window. During the calibration time window, the controller may identify a baseline intrinsic motion level by identifying a motion level of the IMD using the motion sensor during the systole phase of N intrinsically initiated heart beats, where N is greater than two and identify a baseline pace motion level by identifying a motion level of the IMD using the motion sensor during the systole phase of N pace initiated heart beats, where N is greater than two. The controller may then determine an offset based at least in part on the baseline intrinsic motion level and the baseline pace motion level. After the calibration time window and for an intrinsically initiated heart beat that immediately follows a pace initiated heart beat, the controller may identify a motion level of the IMD using the motion sensor during the systole phase of the intrinsically initiated heart beat and apply the offset, and compare the identified motion level of the IMD with the applied offset to a motion level of the IMD identified for the

immediately preceding pace initiated heart beat, and identify a motion level of the patient based at least in part on the comparison. Based at least in part on the identified motion level of the patient, the controller may set a pacing rate parameter.

Additionally, or alternatively to the first illustrative embodiment, after the calibration time window and for a pace initiated heart beat that immediately follows an intrinsic initiated heart beat, the controller may identify a motion level of the IMD using the motion sensor during the systole phase of the pace initiated heart beat and apply the offset, and compare the identified motion level of the LMD with the applied offset to a motion level of the LMD identified for the immediately preceding intrinsically initiated heart beat, and identify a motion level of the patient based at least in part on the comparison.

Additionally, or alternatively, in any of the above embodiments with respect to the first illustrative embodiment, after the calibration time window and for an intrinsically initiated heart beat that immediately follows an intrinsically initiated heart beat, the controller may identify a motion level of the IMD using the motion sensor during the systole phase of the intrinsically initiated heart beat, and compare the identified motion level of the IMD to a motion level of the IMD identified for one or more previous intrinsically initiated heart beats, and identify a motion level of the patient based at least in part on the comparison.

Additionally, or alternatively, in any of the above embodiments with respect to the first illustrative embodiment, after the calibration time window and for a pace initiated heart beat that immediately follows a pace initiated heart beat, the controller may identify a motion level of the IMD using the motion sensor during the systole phase of the pace initiated heart beat, and compare the identified motion level of the IMD to a motion level of the IMD identified for one or more previous pace initiated heart beats, and identify the motion level of the patient based at least in part on the comparison.

Additionally, or alternatively, in any of the above embodiments with respect to the first illustrative embodiment, the N intrinsically initiated heart beats may be N consecutive intrinsically initiated heart beats.

Additionally, or alternatively, in any of the above embodiments with respect to the first illustrative embodiment, the N pace initiated heart beats may be N consecutive pace initiated heart beats.

Additionally, or alternatively, in any of the above embodiments with respect to the first illustrative embodiment, the calibration time window may be a time window where patient activity is expected to be low.

Additionally, or alternatively, in any of the above embodiments with respect to the first illustrative embodiment, the calibration time window may be initiated after a particular posture of the patient is detected by the IMD.

Additionally, or alternatively, in any of the above embodiments with respect to the first illustrative embodiment, the IMD may detect each of N different postures, wherein N is greater than two, and the controller may identify a calibration time window for each N different postures. During each calibration time window, the controller may identify a baseline intrinsic motion level for the corresponding posture by identifying a motion level of the IMD using the motion sensor during the systole phase of N intrinsically initiated heart beats, where N is greater than two. The controller may also identify a baseline pace motion level for the corresponding posture by identifying a motion level of the IMD using the motion sensor during the systole phase of N pace initiated heart beats, where N is greater than two. Based at

least in part on the baseline intrinsic motion level that corresponds to the corresponding posture and the baseline pace motion level that corresponds to the corresponding posture, the controller may determine an offset for each of the N different postures. After the calibration time window for each of the N different postures, the controller may identify a current posture of the patient as one of the N different postures. For an intrinsically initiated heart beat that immediately follows a pace initiated heart beat, the controller may identify a motion level of the IMD using the motion sensor during the systole phase of the intrinsically initiated heart beat, apply the offset that corresponds to the current posture, compare the identified motion level of the with the applied offset that corresponds to the current posture to a motion level of the IMD identified for the immediately preceding pace initiated heart beat, and identify a motion level of the patient based at least in part on the comparison. For a pace initiated heart beat that immediately follows an intrinsically initiated heart beat, the controller may identify a motion level of the IMD using the motion sensor during the systole phase of the pace initiated heart beat, apply the offset that corresponds to the current posture, compare the identified motion level of the IMD with the applied offset that corresponds to the current posture to a motion level of the IMD identified for the immediately preceding intrinsically initiated heart beat, and identify a motion level of the patient based at least in part on the comparison.

Additionally, or alternatively, in any of the above embodiments with respect to the first illustrative embodiment, wherein the calibration time window is initiated at a particular time of day.

Additionally, or alternatively, in any of the above embodiments with respect to the first illustrative embodiment, wherein the calibration time window is initiated after the motion level of the patient falls below a threshold for at least a predetermined length of time.

Additionally, or alternatively, in any of the above embodiments with respect to the first illustrative embodiment, wherein during the calibration time window the controller may pace the patient's heart at a pacing rate that is above a current intrinsic heart rate of the patient, and while pacing the patient's heart at the pacing rate that is above the current intrinsic heart rate of the patient, identify the baseline pace motion level by identifying the motion level of the using the motion sensor during the systole phase of N pace initiated heart beats, where N is greater than two.

In another illustrative embodiment, a method for identifying an activity level of a patient using a motion sensor implanted within the patient's heart may comprise identifying a plurality of heart beats using one or more of the sensors, each of the plurality of heart beats having a systole phase and diastole phase, identifying each of two or more of the plurality of heart beats as an intrinsically initiated heart beat or a pace initiated heart beat, and identifying a calibration time window. During the calibration time window, the method may comprise identifying a baseline intrinsic motion level by identifying a motion level of the IMD using the motion sensor during the systole phase of N intrinsically initiated heart beats, where N is greater than two, and identifying a baseline pace motion level by identifying a motion level of the IMD using the motion sensor during the systole phase of N pace initiated heart beats, where N is greater than two. The method may further comprise determining an offset based at least in part on the baseline intrinsic motion level and the baseline pace motion level. After the calibration time window and for an intrinsically

initiated heart beat that immediately follows a pace initiated heart beat, the may comprise identifying a motion level of the IMD using the motion sensor during the systole phase of the intrinsically initiated heart beat and apply the offset, comparing the identified motion level of the IMD with the applied offset to a motion level of the IMD identified for the immediately preceding pace initiated heart beat, and identifying a motion level of the patient based at least in part on the comparison.

Additionally, or alternatively, the second illustrative embodiment may further comprise, setting a pacing rate parameter based at least in part on the identified motion level of the patient.

Additionally, or alternatively, to any of the above embodiments with respect to the second illustrative embodiment, after the calibration time window and for a pace initiated heart beat that immediately follows an intrinsic initiated heart beat, the method may further comprise identifying a motion level of the IMD using the motion sensor during the systole phase of the pace initiated heart beat and apply the offset, comparing the identified motion level of the IMD with the applied offset to a motion level of the IMD identified for the immediately preceding intrinsically initiated heart beat, and identifying a motion level of the patient based at least in part on the comparison.

Additionally, or alternatively, to any of the above embodiments with respect to the second illustrative embodiment, after the calibration time window and for an intrinsically initiated heart beat that immediately follows an intrinsically initiated heart beat, the method may further comprise identifying a motion level of the IMD using the motion sensor during the systole phase of the intrinsically initiated heart beat, comparing the identified motion level of the IMD to a motion level of the identified for one or more previous intrinsically initiated heart beats, and identifying a motion level of the patient based at least in part on the comparison. After the calibration time window and for a pace initiated heart beat that immediately follows a pace initiated heart beat, the method may further comprise identifying a motion level of the IMD using the motion sensor during the systole phase of the pace initiated heart beat, comparing the identified motion level of the IMD to a motion level of the IMD identified for one or more previous pace initiated heart beats, and identifying the motion level of the patient based at least in part on the comparison.

Additionally, or alternatively, to any of the above embodiments with respect to the second illustrative embodiment, the N intrinsically initiated heart beats may be N consecutive intrinsically initiated heart beats, and the N pace initiated heart beats may be N consecutive pace initiated heart beats.

In another illustrative embodiment, a leadless cardiac pacemaker (LCP) implantable within a patient's heart may comprise a housing, two or more electrodes secured relative to the housing, an accelerometer situated inside of the housing, and circuitry situated inside of the housing and operatively coupled to the two or more electrodes and the accelerometer. The two or more electrodes are configured to sense electrical signals of the patient's heart. The circuitry may identify a plurality of heart beats using two or more of the electrodes, each of the plurality of heart beats having a systole phase and diastole phase. The circuitry may also identify each of two or more of the plurality of heart beats as an intrinsically initiated heart beat or a pace initiated heart beat, and identify a calibration time window. During the calibration time window, the circuitry may identify a baseline intrinsic motion level by identifying a motion level of the LCP using the accelerometer during the systole phase of

N intrinsically initiated heart beats, where N is greater than two, and identify a baseline pace motion level by identifying a motion level of the LCP using the accelerometer during the systole phase of N pace initiated heart beats, where N is greater than two. Based at least in part on the baseline intrinsic motion level and the baseline pace motion level, the circuitry may identify an offset. After the calibration time window and for an intrinsically initiated heart beat that immediately follows a pace initiated heart beat, the circuitry may identify a motion level of the LCP using the accelerometer during the systole phase of the intrinsically initiated heart beat and apply the offset, compare the identified motion level of the LCP with the applied offset to a motion level of the LCP identified for the immediately preceding pace initiated heart beat, and identify a motion level of the patient based at least in part on the comparison. After the calibration time window and for a pace initiated heart beat that immediately follows an intrinsic initiated heart beat, the circuitry may identify a motion level of the LCP using the accelerometer during the systole phase of the pace initiated heart beat and apply the offset, compare the identified motion level of the LCP with the applied offset to a motion level of the LCP identified for the immediately preceding intrinsically initiated heart beat, and identify a motion level of the patient based at least in part on the comparison. After the calibration time window and for an intrinsically initiated heart beat that immediately follows an intrinsically initiated heart beat, the circuitry may identify a motion level of the LCP using the accelerometer during the systole phase of the intrinsically initiated heart beat, compare the identified motion level of the LCP to a motion level of the LCP identified for one or more previous intrinsically initiated heart beats, and identify a motion level of the patient based at least in part on the comparison. After the calibration time window and for a pace initiated heart beat that immediately follows a pace initiated heart beat, the circuitry may identify a motion level of the LCP using the accelerometer during the systole phase of the pace initiated heart beat, and compare the identified motion level of the LCP to a motion level of the LCP identified for one or more previous pace initiated heart beats, and identify the motion level of the patient based at least in part on the comparison. Based at least in part on the identified motion level of the patient, the circuitry may set a pacing rate parameter.

Additionally, or alternatively, to the third illustrative embodiment, the N intrinsically initiated heart beats may be N consecutive intrinsically initiated heart beats, and the N pace initiated heart beats may be N consecutive pace initiated heart beats.

Additionally, or alternatively, to any of the above embodiments with respect to the third illustrative embodiment, the calibration time window may be a time window where patient activity is expected to be low.

The above summary is not intended to describe each embodiment or every implementation of the present disclosure. Advantages and attainments, together with a more complete understanding of the disclosure, will become apparent and appreciated by referring to the following description and claims taken in conjunction with the accompanying drawings.

BRIEF DESCRIPTION OF THE DRAWINGS

The disclosure may be more completely understood in consideration of the following description of various illustrative embodiments in connection with the accompanying drawings, in which:

FIG. 1 is a schematic block diagram of an illustrative leadless cardiac pacemaker (LCP) according to one embodiment of the present disclosure;

FIG. 2 is a schematic block diagram of another illustrative medical device that may be used in conjunction with the LCP of FIG. 1;

FIG. 3 is a schematic diagram of an exemplary medical system that includes multiple LCPs and/or other devices in communication with one another;

FIG. 4 is a schematic diagram of a system including an LCP and another medical device, in accordance with another embodiment of the present disclosure;

FIG. 5 depicts a graph showing a cardiac electrical signal and illustrative motion sensor signal tracings for both an intrinsically initiated heart beat and a pace initiated heart beat;

FIG. 6 depicts a schematic flow diagram of an illustrative technique for setting a pacing rate parameter for an LCP;

FIG. 7 depicts a schematic flow diagram of an illustrative technique for setting a pacing rate parameter for an LCP;

FIG. 8 depicts a schematic flow diagram of an illustrative technique for setting a pacing rate parameter for an LCP utilizing heart rate range classifications;

FIG. 9 depicts a schematic flow diagram of an illustrative technique for setting a pacing rate parameter for an LCP utilizing an offset;

FIG. 10 depicts a schematic flow diagram of an illustrative technique for setting a pacing rate parameter for an LCP utilizing a calibration window; and

FIGS. 11A-11C depict graphs of illustrative averaged raw accelerometer data for a plurality of heart beats.

While the disclosure is amenable to various modifications and alternative forms, specifics thereof have been shown by way of embodiment in the drawings and will be described in detail. It should be understood, however, that the intention is not to limit aspects of the disclosure to the particular illustrative embodiments described. On the contrary, the intention is to cover all modifications, equivalents, and alternatives falling within the spirit and scope of the disclosure.

DESCRIPTION

The following description should be read with reference to the drawings in which similar elements in different drawings are numbered the same. The description and the drawings, which are not necessarily to scale, depict illustrative embodiments and are not intended to limit the scope of the disclosure.

This disclosure describes systems, devices, and methods for modifying delivery of pacing pulses according to a motion level of a patient. For example, devices of the present disclosure may be configured to determine a motion level of a patient. The devices may then adjust the rate of delivery of pacing pulses in accordance with the determined motion level. As one example, the devices may slow the delivery rate of pacing pulses during periods of lower patient motion relative to a delivery rate of pacing pulses during periods of higher patient motion.

FIG. 1 is a conceptual schematic block diagram of an implantable medical device (IMD), such as an illustrative leadless cardiac pacemaker (LCP) that may be implanted on the heart or within a chamber of the heart and may operate to sense physiological signals and parameters and deliver one or more types of electrical stimulation therapy to the heart of the patient. Example electrical stimulation therapy may include bradycardia pacing, rate responsive pacing

therapy, cardiac resynchronization therapy (CRT), anti-tachycardia pacing (ATP) therapy and/or the like. The disclosed concepts may be implemented in other IMDs and/or other devices including, but not limited to, pacemakers with leads, defibrillators, and/or other implantable or non-implantable devices.

As can be seen in FIG. 1, LCP 100 may be a compact device with all components housed within LCP 100 or directly on housing 120. In some instances, LCP 100 may include communication module 102, pulse generator module 104, electrical sensing module 106 (e.g., including one or more electrical sensors), mechanical sensing module 108 (e.g., including one or more mechanical sensors), processing module 110 (e.g., a controller including memory and one or more processors), energy storage module 112, and electrodes 114, 114'. Via circuitry, the electrodes 114, 114' may be part of and/or may be in communication with (e.g., operatively coupled to) the communication module 102, the pulse generator module 104, electrical sensing module 106, the mechanical sensing module 108, the processing module 110, and/or the energy storage module 112.

As depicted in FIG. 1, LCP 100 may include electrodes 114, which can be secured relative to housing 120 and electrically exposed to tissue and/or blood surrounding LCP 100. Electrodes 114 may generally conduct electrical signals to and/or from LCP 100 and the surrounding tissue and/or blood. Such electrical signals may include communication signals, electrical stimulation pulses, and intrinsic cardiac electrical signals, to name a few. Intrinsic cardiac electrical signals may include electrical signals generated by the heart and may be represented by an electrocardiogram (ECG). The electrodes may be considered a sensor capable of sensing each of a plurality of heart beats.

Electrodes 114 may include one or more biocompatible conductive materials such as various metals or alloys that are known to be safe for implantation within a human body. In some instances, electrodes 114 may be generally disposed on either end of LCP 100 and may be in electrical communication with one or more of modules 102, 104, 106, 108, and 110. In embodiments where electrodes 114 (e.g., two or more electrodes 114) are secured directly to housing 120, an insulative material may electrically isolate the electrodes 114 from adjacent electrodes, housing 120, and/or other parts of LCP 100. In some instances, some or all of electrodes 114 may be spaced from housing 120 and connected to housing 120 and/or other components of LCP 100 through connecting wires. In such instances, the electrodes 114 may be placed on a tail (not shown) that extends out away from the housing 120.

As shown in FIG. 1, in some embodiments, LCP 100 may include electrodes 114'. Electrodes 114' may be in addition to electrodes 114, or may replace one or more of electrodes 114. Electrodes 114' may be similar to electrodes 114 except that electrodes 114' are disposed on the sides of LCP 100. In some cases, electrodes 114' may increase the number of electrodes by which LCP 100 may deliver communication signals and/or electrical stimulation pulses, and/or may sense intrinsic cardiac electrical signals, communication signals, and/or electrical stimulation pulses.

Electrodes 114 and/or 114' may assume any of a variety of sizes and/or shapes, and may be spaced at any of a variety of spacings. For example, electrodes 114 may have an outer diameter of two to twenty millimeters (mm). In other embodiments, electrodes 114 and/or 114' may have a diameter of two, three, five, seven millimeters (mm), or any other suitable diameter, dimension and/or shape. Example lengths for electrodes 114 and/or 114' may include, for example,

one, three, five, ten millimeters (mm), or any other suitable length. As used herein, the length is a dimension of electrodes 114 and/or 114' that extends away from the outer surface of the housing 120, in some instances, at least some of electrodes 114 and/or 114' may be spaced from one another by a distance of twenty, thirty, forty, fifty millimeters), or any other suitable spacing. The electrodes 114 and/or 114' of a single device may have different sizes with respect to each other, and the spacing and/or lengths of the electrodes on the device may or may not be uniform.

In the embodiment shown, communication module 102 may be electrically coupled to electrodes 114 and/or 114' and may be configured to deliver communication pulses to tissues of the patient for communicating with other devices such as sensors, programmers, other medical devices, and/or the like. Communication signals, as used herein, may be any modulated signal that conveys information to another device, either by itself or in conjunction with one or more other modulated signals. In some embodiments, communication signals may be limited to sub-threshold signals that do not result in capture of the heart yet still convey information. The communication signals may be delivered to another device that is located either external or internal to the patient's body. In some instances, the communication may take the form of distinct communication pulses separated by various amounts of time. In some of these cases, the timing between successive pulses may convey information. Communication module 102 may additionally be configured to sense for communication signals delivered by other devices, which may be located external or internal to the patient's body.

Communication module 102 may communicate to help accomplish one or more desired functions. Some example functions include delivering sensed data, using communicated data for determining occurrences of events such as arrhythmias, coordinating delivery of electrical stimulation therapy, and/or other functions. In some cases, LCP 100 may use communication signals to communicate raw information, processed information, messages and/or commands, and/or other data. Raw information may include information such as sensed electrical signals (e.g. a sensed ECG), signals gathered from coupled sensors, and the like. In some embodiments, the processed information may include signals that have been filtered using one or more signal processing techniques. Processed information may also include parameters and/or events that are determined by the LCP 100 and/or another device, such as a determined heart rate, timing of determined heartbeats, timing of other determined events, determinations of threshold crossings, expirations of monitored time periods, accelerometer signals, activity level parameters, blood-oxygen parameters, blood pressure parameters, heart sound parameters, and the like. Messages and/or commands may include instructions or the like directing another device to take action, notifications of imminent actions of the sending device, requests for reading from the receiving device, requests for writing data to the receiving device, information messages, and/or other messages commands.

In at least some embodiments, communication module 102 (or LCP 100) may further include switching circuitry to selectively connect one or more of electrodes 114 and/or 114' to communication module 102 in order to select which electrodes 114 and/or 114' that communication module 102 delivers communication pulses. It is contemplated that communication module 102 may be communicating with other devices via conducted signals, radio frequency (RF) signals,

optical signals, acoustic signals, inductive coupling, and/or any other suitable communication methodology.

Where communication module **102** generates electrical communication signals, communication module **102** may include one or more capacitor elements and/or other charge storage devices to aid in generating and delivering communication signals. In the embodiment shown, communication module **102** may use energy stored in energy storage module **112** to generate the communication signals. In at least some examples, communication module **102** may include a switching circuit that is connected to energy storage module **112** and, with the switching circuitry, may connect energy storage module **112** to one or more of electrodes **114/114'** to generate the communication signals.

As shown in FIG. 1, a pulse generator module **104** may be electrically connected to one or more of electrodes **114** and/or **114'**. Pulse generator module **104** may be configured to generate electrical stimulation pulses and deliver the electrical stimulation pulses to tissues of a patient via one or more of the electrodes **114** and/or **114'** in order to effectuate one or more electrical stimulation therapies. Electrical stimulation pulses as used herein are meant to encompass any electrical signals that may be delivered to tissue of a patient for purposes of treatment of any type of disease or abnormality. For example, when used to treat heart disease, the pulse generator module **104** may generate electrical stimulation pacing pulses for capturing the heart of the patient, i.e. causing the heart to contract in response to the delivered electrical stimulation pulse. In some of these cases, LCP **100** may vary the rate at which pulse generator module **104** generates the electrical stimulation pulses, for example in rate adaptive pacing. In other embodiments, the electrical stimulation pulses may include defibrillation/cardioversion pulses for shocking the heart out of fibrillation or into a normal heart rhythm. In yet other embodiments, the electrical stimulation pulses may include anti-tachycardia pacing (ATP) pulses. It should be understood that these are just some examples. When used to treat other ailments, the pulse generator module **104** may generate electrical stimulation pulses suitable for neurostimulation therapy or the like.

Pulse generator module **104** may include one or more capacitor elements and/or other charge storage devices to aid in generating and delivering appropriate electrical stimulation pulses. In at least some embodiments, pulse generator module **104** may use energy stored in energy storage module **112** to generate the electrical stimulation pulses. In some particular embodiments, pulse generator module **104** may include a switching circuit that is connected to energy storage module **112** and may connect energy storage module **112** to one or more of electrodes **114/114'** to generate electrical stimulation pulses.

LCP **100** may include an electrical sensing module **106**. Electrical sensing module **106** may be configured to sense intrinsic cardiac electrical signals conducted from electrodes **114** and/or **114'** to electrical sensing module **106**. For example, electrical sensing module **106** may be electrically connected to one or more electrodes **114** and/or **114'** and electrical sensing module **106** may be configured to receive cardiac electrical signals conducted through electrodes **114** and/or **114'** via a sensor amplifier or the like. In some embodiments, the cardiac electrical signals may represent local information from the chamber in which LCP **100** is implanted. For instance, if LCP **100** is implanted within a ventricle of the heart, cardiac electrical signals sensed by LCP **100** through electrodes **114** and/or **114'** may represent ventricular cardiac electrical signals. The electrical sensing

module **106** may, in some cases, be configured to identify each of a plurality of heart beats as an intrinsically initiated heart beat or a pace initiated heart beat.

Further, LCP **100** may include a mechanical sensing module **108**. Mechanical sensing module **108** may include, or be electrically connected to, various sensors, such as accelerometers, including multi-axis accelerometers such as two- or three-axis accelerometers, gyroscopes, including multi-axis gyroscopes such as two- or three-axis gyroscopes, blood pressure sensors, heart sound sensors, piezoelectric sensors, blood-oxygen sensors, and/or other sensors which measure one or more physiological parameters of the heart and/or patient. Mechanical sensing module **108**, when present, may gather signals from the sensors indicative of the various physiological parameters.

Both electrical sensing module **106** and mechanical sensing module **108** may be connected to processing module **110** and may provide signals representative of the sensed cardiac electrical signals and/or physiological signals to processing module **110**. Although described with respect to FIG. 1 as separate sensing modules, in some embodiments, electrical sensing module **106** and mechanical sensing module **108** may be combined into a single module. In at least some examples, LCP **100** may only include one of electrical sensing module **106** and mechanical sensing module **108**. In some cases, any combination of the processing module **110**, electrical sensing module **106**, mechanical sensing module **108**, communication module **102**, pulse generator module **104** and/or energy storage module may be considered a controller of the **100**.

Processing module **110** may be configured to direct the operation of LCP **100** and may, in some embodiments, be termed a controller. For example, processing module **110** may be configured to receive cardiac electrical signals from electrical sensing module **106** and/or physiological signals from mechanical sensing module **108**. Based on the received signals, processing module **110** may, for example, adjust the rate of pacing based on the activity level of the patient (e.g. rate adaptive pacing). When so provided, processing module **110** may monitor one or more physiological parameters of the patient which may indicate a need for an increased heart rate (e.g. due to increased metabolic demand) and increase the rate at which pulse generator module **104** generates electrical stimulation pulses. Determining an activity level of the patient using a motion sensor (e.g. accelerometer) of the mechanical sensing module **108** of the LCP **100** can be challenging because the motion detected by the motion sensor not only includes the activity level of the patient but also the motion of the beating heart. FIGS. 6-10 describes illustrative methods for aiding in rate responsive pacing using a motion sensor accelerometer) in an LCP.

In some cases, the processing module **110** may determine occurrences and types of arrhythmias and other determinations such as whether LCP **100** has become dislodged. Processing module **110** may further receive information from communication module **102**. In some embodiments, processing module **110** may additionally use such received information to determine occurrences and types of arrhythmias and/or other determinations such as whether LCP **100** has become dislodged. In still some additional embodiments, LCP **100** may use the received information instead of the signals received from electrical sensing module **106** and/or mechanical sensing module **108**—for instance if the received information is deemed to be more accurate than the signals received from electrical sensing module **106** and/or mechanical sensing module **108** or if electrical sensing

module **106** and/or mechanical sensing module **108** have been disabled or omitted from LCP **100**.

After determining an occurrence of an arrhythmia, processing module **110** may control pulse generator module **104** to generate electrical stimulation pulses in accordance with one or more electrical stimulation therapies to treat the determined arrhythmia. For example, processing module **110** may control pulse generator module **104** to generate pacing pulses with varying parameters and in different sequences to effectuate one or more electrical stimulation therapies. As one example, in controlling pulse generator module **104** to deliver bradycardia pacing therapy, processing module **110** may control pulse generator module **104** to deliver pacing pulses designed to capture the heart of the patient at a regular interval to help prevent the heart of a patient from falling below a predetermined threshold.

For ATP therapy, processing module **110** may control pulse generator module **104** to deliver pacing pulses at a rate faster than an intrinsic heart rate of a patient in an attempt to force the heart to beat in response to the delivered pacing pulses rather than in response to intrinsic cardiac electrical signals. Once the heart is following the pacing pulses, processing module **110** may control pulse generator module **104** to reduce the rate of delivered pacing pulses down to a safer level. In Cardiac Resynchronization Therapy (CRT), processing module **110** may control pulse generator module **104** to deliver pacing pulses in coordination with another device to cause the heart to contract more efficiently. In cases where pulse generator module **104** is capable of generating defibrillation and/or cardioversion pulses for defibrillation/c cardioversion therapy, processing module **110** may control pulse generator module **104** to generate such defibrillation and/or cardioversion pulses. In some cases, processing module **110** may control pulse generator module **104** to generate electrical stimulation pulses to provide electrical stimulation therapies different than those examples described above.

Aside from controlling pulse generator module **104** to generate different types of electrical stimulation pulses and in different sequences, in some embodiments, processing module **110** may also control pulse generator module **104** to generate the various electrical stimulation pulses with varying pulse parameters. For example, each electrical stimulation pulse may have a pulse width and a pulse amplitude. Processing module **110** may control pulse generator module **104** to generate the various electrical stimulation pulses with specific pulse widths and pulse amplitudes. For example, processing module **110** may cause pulse generator module **104** to adjust the pulse width and/or the pulse amplitude of electrical stimulation pulses if the electrical stimulation pulses are not effectively capturing the heart. Such control of the specific parameters of the various electrical stimulation pulses may help LCP **100** provide more effective delivery of electrical stimulation therapy.

In some embodiments, processing module **110** may further control communication module **102** to send information to other devices. For example, processing module **110** may control communication module **102** to generate one or more communication signals for communicating with other devices of a system of devices. For instance, processing module **110** may control communication module **102** to generate communication signals in particular pulse sequences, where the specific sequences convey different information. Communication module **102** may also receive communication signals for potential action by processing module **110**.

In further embodiments, processing module **110** may control switching circuitry by which communication module

102 and pulse generator module **104** deliver communication signals and/or electrical stimulation pulses to tissue of the patient. As described above, both communication module **102** and pulse generator module **104** may include circuitry for connecting one or more electrodes **114** and/**114'** to communication module **102** and/or pulse generator module **104** so those modules may deliver the communication signals and electrical stimulation pulses to tissue of the patient. The specific combination of one or more electrodes by which communication module **102** and/or pulse generator module **104** deliver communication signals and electrical stimulation pulses may influence the reception of communication signals and/or the effectiveness of electrical stimulation pulses. Although it was described that each of communication module **102** and pulse generator module **104** may include switching circuitry, in some embodiments, LCP **100** may have a single switching module connected to the communication module **102**, the pulse generator module **104**, and electrodes **114** and/or **114'**. In such embodiments, processing module **110** may control the switching module to connect modules **102/104** and electrodes **114/114'** as appropriate.

In some embodiments, processing module **110** may include a pre-programmed chip, such as a very-large-scale integration (VLSI) chip or an application specific integrated circuit (ASIC). In such embodiments, the chip may be pre-programmed with control logic in order to control the operation of LCP **100**. By using a pre-programmed chip, processing module **110** may use less power than other programmable circuits while able to maintain basic functionality, thereby potentially increasing the battery life of LCP **100**. In other instances, processing module **110** may include a programmable microprocessor or the like. Such a programmable microprocessor may allow a user to adjust the control logic of LCP **100** after manufacture, thereby allowing for greater flexibility of LCP **100** than when using a pre-programmed chip. In still other embodiments, processing module **110** may not be a single component. For example, processing module **110** may include multiple components positioned at disparate locations within LCP **100** in order to perform the various described functions. For example, certain functions may be performed in one component of processing module **110**, while other functions are performed in a separate component of processing module **110**.

Processing module **110**, in additional embodiments, may include a memory circuit and processing module **110** may store information on and read information from the memory circuit. In other embodiments, LCP **100** may include a separate memory circuit (not shown) that is in communication with processing module **110**, such that processing module **110** may read and write information to and from the separate memory circuit. The memory circuit, whether part of processing module **110** or separate from processing module **110**, may be volatile memory, non-volatile memory, or a combination of volatile memory and non-volatile memory.

Energy storage module **112** may provide a power source to LCP **100** for its operations. In some embodiments, energy storage module **112** may be a non-rechargeable lithium-based battery. In other embodiments, the non-rechargeable battery may be made from other suitable materials. In some embodiments, energy storage module **112** may include a rechargeable battery. In still other embodiments, energy storage module **112** may include other types of energy storage devices such as capacitors or super capacitors.

To implant LCP 100 inside a patient's body, an operator (a physician, clinician, etc.), may fix LCP 100 to the cardiac tissue of the patient's heart. To facilitate fixation, LCP 100 may include one or more anchors 116. The one or more anchors 116 are shown schematically in FIG. 1. The one or more anchors 116 may include any number of fixation or anchoring mechanisms. For example, one or more anchors 116 may include one or more pins, staples, threads, screws, helix, tines, and/or the like. In some embodiments, although not shown, one or more anchors 116 may include threads on its external surface that may run along at least a partial length of an anchor member. The threads may provide friction between the cardiac tissue and the anchor to help fix the anchor member within the cardiac tissue. In some cases, the one or more anchors 116 may include an anchor member that has a cork-screw shape that can be screwed into the cardiac tissue. In other embodiments, anchor 116 may include other structures such as barbs, spikes, or the like to facilitate engagement with the surrounding cardiac tissue.

In some examples, LCP 100 may be configured to be implanted on a patient's heart or within a chamber of the patient's heart. For instance, LCP 100 may be implanted within any of a left atrium, right atrium, left ventricle, or right ventricle of a patient's heart. By being implanted within a specific chamber, LCP 100 may be able to sense cardiac electrical signals originating or emanating from the specific chamber that other devices may not be able to sense with such resolution. Where LCP 100 is configured to be implanted on a patient's heart, LCP 100 may be configured to be implanted on or adjacent to one of the chambers of the heart, or on or adjacent to a path along which intrinsically generated cardiac electrical signals generally follow. In these examples, LCP 100 may also have an enhanced ability to sense localized intrinsic cardiac electrical signals and deliver localized electrical stimulation therapy. In embodiments where LCP 100 includes an accelerometer, LCP 100 may additionally be able to sense the motion of the cardiac wall to which LCP 100 is attached.

FIG. 2 depicts an embodiment of another device, medical device (MD) 200, which may operate to sense physiological signals and parameters and deliver one or more types of electrical stimulation therapy to tissues of the patient. In the embodiment shown, MD 200 may include a communication module 202, a pulse generator module 204, an electrical sensing module 206, a mechanical sensing module 208, a processing module 210, and an energy storage module 218. Each of modules 202, 204, 206, 208, and 210 may be similar to and/or different than modules 102, 104, 106, 108, and 110 of LCP 100 in one or more manners. Additionally, energy storage module 218 may be similar to and/or different than energy storage module 112 of LCP 100 in one or more manners. However, in some embodiments, MD 200 may have a larger volume within housing 220 than a volume of LCP 100. In such embodiments, MD 200 may include a larger energy storage module 218 and/or a larger processing module 210 capable of handling more complex operations than processing module 110 of LCP 100.

While MI 200 may be another leadless device such as shown in FIG. 1, in some instances MD 200 may include leads, such as leads 212. Leads 212 may include electrical wires that conduct electrical signals between electrodes 214 and one or more modules located within housing 220. In some cases, leads 212 may be connected to and extend away from housing 220 of MD 200. In some embodiments, leads 212 may be implanted on, within, or adjacent to a heart of a patient. Leads 212 may contain one or more electrodes 214 positioned at various locations on leads 212 and various

distances from housing 220. Some leads 212 may only include a single electrode 214, while other leads 212 may include multiple electrodes 214. Generally, electrodes 214 may be positioned on leads 212 such that when leads 212 are implanted within the patient, one or more of the electrodes 214 are positioned to perform a desired function. In some cases, the one or more of the electrodes 214 may be in contact with the patient's cardiac tissue. In other cases, the one or more of the electrodes 214 may be positioned subcutaneously but adjacent to the patient's heart.

MD 200 may also include one or more electrodes 214 not disposed on a lead 212. For example, one or more electrodes 214 may be connected directly to housing 220.

The electrodes 214 may conduct intrinsically generated electrical cardiac signals to leads 212. Leads 212 may, in turn, conduct the received electrical cardiac signals to one or more of the modules 202, 204, 206, and 208 of MD 200.

In some cases, MD 200 may generate electrical stimulation signals, and leads 212 may conduct the generated electrical stimulation signals to electrodes 214. Electrodes 214 may then conduct the electrical stimulation signals to the cardiac tissue of the patient (either directly or indirectly).

Leads 212, in some embodiments, may additionally contain one or more sensors, such as accelerometers, blood pressure sensors, heart sound sensors, blood-oxygen sensors, and/or other sensors which are configured to measure one or more physiological parameters of the heart and/or patient. In such embodiments, mechanical sensing module 208 may be in electrical communication with leads 212 and may receive signals generated from such sensors.

While not required, in some embodiments MI 200 may be an implantable medical device. In such embodiments, housing 220 of MD 200 may be implanted in, for example, a transthoracic region of the patient. Housing 220 may generally include any of a number of known materials that are safe for implantation in a human body and may, when implanted, hermetically seal the various components of MD 200 from fluids and tissues of the patient's body. In such embodiments, leads 212 may be implanted at one or more various locations within the patient, such as within the heart of the patient, adjacent to the heart of the patient, adjacent to the spine of the patient, or any other desired location.

In some embodiments, MD 200 may be an implantable cardiac pacemaker (ICP). In these embodiments, MD 200 may have one or more leads, for example leads 212, which are implanted on or within the patient's heart. The one or more leads 212 may include one or more electrodes 214 that are in contact with cardiac tissue and/or blood of the patient's heart. MD 200 may be configured to sense intrinsically generated cardiac electrical signals and determine, for example, one or more cardiac arrhythmias based on analysis of the sensed signals. MD 200 may be configured to deliver CRT, ATP therapy, bradycardia therapy, and/or other therapy types via leads 212 implanted within the heart. In some embodiments, MD 200 may additionally be configured to provide defibrillation/cardioversion therapy.

In some instances, MD 200 may be an implantable cardioverter-defibrillator (ICD). In such embodiments, MD 200 may include one or more leads implanted within a patient's heart. MD 200 may also be configured to sense electrical cardiac signals, determine occurrences of tachyarrhythmias based on the sensed electrical cardiac signals, and deliver defibrillation and/or cardioversion therapy in response to determining an occurrence of a tachyarrhythmia (for example by delivering defibrillation and/or cardioversion pulses to the heart of the patient). In other embodiments, MD 200 may be a subcutaneous implantable cardio-

verter-defibrillator (SICD). In embodiments where MD 200 is an SICD, one of leads 212 may be a subcutaneously implanted lead. In at least some embodiments where MD 200 is an SICD, MD 200 may include only a single lead which is implanted subcutaneously but outside of the chest cavity, however this is not required.

In some embodiments, MD 200 may not be an implantable medical device. Rather, MD 200 may be a device external to the patient's body, and electrodes 214 may be skin-electrodes that are placed on a patient's body. In such embodiments, MD 200 may be able to sense surface electrical signals (e.g. electrical cardiac signals that are generated by the heart or electrical signals generated by a device implanted within a patient's body and conducted through the body to the skin). MD 200 may further be configured to deliver various types of electrical stimulation therapy, including, for example, defibrillation therapy via skin-electrodes 214.

FIG. 3 illustrates an embodiment of a medical device system and a communication pathway through which multiple medical devices 100a, 100b, 306, and/or 310 of the medical device system may communicate. In the embodiment shown, medical device system 300 may include a first LCP 100a and a second LCP 100b, external medical device 306, and other sensors/devices 310.

External device 306 may be a device disposed external to a patient's body, as described previously with respect to MD 200. In at least some examples, external device 306 may represent an external support device such as a device programmer, as will be described in more detail below.

Other sensors/devices 310 may be any of the devices described previously with respect to MD 200, such as ICPs, ICDs, and SICDs. Other sensors/devices 310 may also include various diagnostic sensors that gather information about the patient, such as accelerometers, blood pressure sensors, or the like. In some cases, other sensors/devices 310 may include an external programmer device that may be used to program one or more devices of system 300.

Various devices of system 300 may communicate via communication pathway 308. For example, LCPs 100a and/or 100b may sense intrinsic cardiac electrical signals and may communicate such signals to one or more other devices 100a/100b, 306, and 310 of system 300 via communication pathway 308. In one embodiment, one or more of devices 100a/100b may receive such signals and, based on the received signals, determine an occurrence of an arrhythmia. In some cases, device or devices 100a/100b may communicate such determinations to one or more other devices 306 and 310 of system 300. In some cases, one or more of devices 100a/100b, 306, and 310 of system 300 may take action based on the communicated determination of an arrhythmia, such as by delivering a suitable electrical stimulation to the heart of the patient. One or more of devices 100a/100b, 306, and 310 of system 300 may additionally communicate command or response messages via communication pathway 308. The command messages may cause a receiving device to take a particular action whereas response messages may include requested information or a confirmation that a receiving device did, in fact, receive a communicated message or data.

It is contemplated that the various devices of system 300 may communicate via pathway 308 using RF signals, inductive coupling, optical signals, acoustic signals, or any other signals suitable for communication. Additionally, in at least some embodiments, the various devices of system 300 may communicate via pathway 308 using multiple signal types. For instance, other sensors/device 310 may communicate

with external device 306 using a first signal type (e.g. RF communication) but communicate with LCPs 100a/100b using a second signal type e.g. conducted communication). Further, in some embodiments, communication between devices may be limited. For instance, as described above, in some embodiments, LCPs 100a/100b may communicate with external device 306 only through other sensors/devices 310, where LCPs 100a/100b may send signals to other sensors/devices 310, and other sensors/devices 310 relay the received signals to external device 306.

In some cases, the various devices of system 300 may communicate via pathway 308 using conducted communication signals. Accordingly, devices of system 300 may have components that allow for such conducted communication. For instance, the devices of system 300 may be configured to transmit conducted communication signals (e.g. a voltage and/or current waveform punctuated with current and/or voltage pulses, referred herein as electrical communication pulses) into the patient's body via one or more electrodes of a transmitting device, and may receive the conducted communication signals via one or more electrodes of a receiving device. The patient's body may "conduct" the conducted communication signals from the one or more electrodes of the transmitting device to the electrodes of the receiving device in the system 300. In such embodiments, the delivered conducted communication signals may differ from pacing pulses, defibrillation and/or cardioversion pulses, or other electrical stimulation therapy signals. For example, the devices of system 300 may deliver electrical communication pulses at an amplitude/pulse width that is sub-threshold. That is, the communication pulses have an amplitude/pulse width designed to not capture the heart. In some cases, the amplitude/pulse width of the delivered electrical communication pulses may be above the capture threshold of the heart, but may be delivered during a refractory period of the heart and/or may be incorporated in or modulated onto a pacing pulse, if desired.

Additionally, unlike normal electrical stimulation therapy pulses, the electrical communication pulses may be delivered in specific sequences which convey information to receiving devices. For instance, delivered electrical communication pulses may be modulated in any suitable manner to encode communicated information. In some cases, the communication pulses may be pulse width modulated and/or amplitude modulated. Alternatively, or in addition, the time between pulses may be modulated to encode desired information. In some cases, a predefined sequence of communication pulses may represent a corresponding symbol (e.g. a logic "1" symbol, a logic "0" symbol, an ATP therapy trigger symbol, etc.). In some cases, conducted communication pulses may be voltage pulses, current pulses, biphasic voltage pulses, biphasic current pulses, or any other suitable electrical pulse as desired.

FIG. 4 depicts an illustrative medical device system 400. For example, system 400 may include multiple devices that are implanted within a patient and are configured to sense physiological signals, determine occurrences of cardiac arrhythmias, and deliver electrical stimulation to treat detected cardiac arrhythmias. In some embodiments, the devices of system 400 may be configured to determine occurrences of dislodgment of one or more devices of system 400. In FIG. 4, an LCP 100 is shown fixed to the interior of the right ventricle of the heart 410, and a pulse generator 406 is shown coupled to a lead 412 having one or more electrodes 408a-408c. In some cases, pulse generator 406 may be part of a subcutaneous implantable cardioverter-defibrillator (SICD), and the one or more electrodes 408a-

408c may be positioned subcutaneously adjacent the heart. LCP 100 may communicate with the SICD, such as via communication pathway 308. The locations of LCP 100, pulse generator 406, lead 412, and electrodes 408a-c depicted in FIG. 4 are just exemplary. In other embodiments

of system 400, LCP 100 may be positioned in the left ventricle, right atrium, or left atrium of the heart, as desired. In still other embodiments, LCP 100 may be implanted externally adjacent to heart 410 or even remote from heart 410. Medical device system 400 may also include external support device 420. External support device 420 can be used to perform functions such as device identification, device programming and/or transfer of real-time and/or stored data between devices using one or more of the communication techniques described herein, or other functions involving communication with one or more devices of system 400. As one example, communication between external support device 420 and pulse generator 406 can be performed via a wireless mode, and communication between pulse generator 406 and LCP 100 can be performed via a conducted communication mode. In some embodiments, communication between LCP 100 and external support device 420 is accomplished by sending communication information through pulse generator 406. However, in other embodiments, communication between the LCP 100 and external support device 420 may be via a communication module.

FIG. 4 only illustrates one example embodiment of a medical device system that may be configured to operate according to techniques disclosed herein. Other example medical device systems may include additional or different medical devices and/or configurations. For instance, other medical device systems that are suitable to operate according to techniques disclosed herein may include additional LCPs implanted within the heart. Another example medical device system may include a plurality of LCPs with or without other devices such as pulse generator 406, with at least one LCP capable of delivering defibrillation therapy. Still another example may include one or more LCPs implanted along with a transvenous pacemaker and with or without an implanted SICD. In yet other embodiments, the configuration or placement of the medical devices, leads, and/or electrodes may be different from those depicted in FIG. 4. Accordingly, it should be recognized that numerous other medical device systems, different from system 400 depicted in FIG. 4, may be operated in accordance with techniques disclosed herein. As such, the embodiment shown in FIG. 4 should not be viewed as limiting in any way.

In some embodiments, LCP 100 may be configured to operate in one or more modes. Within each mode, LCP 100 may operate in a somewhat different manner. For instance, in a first mode, LCP 100 may be configured to sense certain signals and/or determine certain parameters from the sensed signals. In a second mode, LCP 100 may be configured to sense at least some different signals and/or determine at least some different parameters than in the first mode. In at least one mode, LCP 100 may be configured to determine a motion level of a patient and modulate delivery of electrical stimulation therapy based on the determined motion level of the patient. For ease of description, a mode that includes LCP 100 being configured to determine a motion level of a patient and modulate delivery of electrical stimulation therapy based on the determined motion level of the patient may be called a motion sensing mode. Other modes may include one or more programming and/or therapy modes, and it may be possible for LCP 100 to be engaged in multiple modes concurrently.

In some embodiments, LCP 100 may include a therapy mode where LCP 100 operates as a pacemaker and delivers electrical stimulation therapy, such as electrical stimulation pulses, to a heart to drive a specific heart rate for the patient.

LCP 100 may be configured to modulate the rate at which LCP 100 delivers electrical stimulation therapy in order to drive different heart rates for the patient. For instance, LCP 100 may be configured to deliver electrical stimulation in a rate-adaptive manner, as described herein. In at least some of these embodiments, LCP 100 may include a motion sensing mode, which may be a specific therapy mode or may modify a therapy mode. In the motion sensing mode, LCP 100 may modulate the rate of delivery of electrical stimulation therapy based on a determined motion level of the patient.

In some cases, the LCP 100 may determine the motion level of the patient using a motion sensor (e.g. accelerometer) in the LCP 100. Determining an activity level of the patient using a motion sensor (e.g. accelerometer) in the LCP 100 can be challenging because the motion detected by the motion sensor not only includes the activity level of the patient but also the motion of the beating heart. Moreover, the motion level of the beating heart may be different for intrinsically initiated heart beats versus pace initiated heart beats.

It has been found that a level of noise in a motion level of a patient (e.g. activity level) may be present when sequential heart beats switch or transition from an intrinsically initiated heart beat to a pace initiated heart and/or switches or transitions from a pace initiated heart beat to an intrinsically initiated heart beat. When adjusting a pacing therapy (e.g., an electrical stimulation therapy) based, at least in part, on a motion level of a patient (e.g. activity level), such noise may result in elevating a patient's heart rate when it is not needed and/or may result in not elevating the patient's heart rate when it is needed. Noise in motion level measurements by a motion sensor in the LCP 100 when heart beats are transitioning between an intrinsically initiated heart beat and a pace initiated heart beat are illustrated in the traces of FIG. 5. FIG. 5 depicts a graph 450 showing a number of signal traces from a motion sensor (e.g. accelerometer) of the LCP 100 when LCP 100 is attached to a wall of a patient's heart. The x-axis of graph 450 is time, t. Electrical signal 452 is an illustrative cardiac electrical signal (e.g., depicting heart beats) sensed by electrodes of the LCP 100. Motion signal 454 is an example signal sensed by an accelerometer of the mechanical sensing module 108 of the LCP 100 assuming two consecutive intrinsically initiated heart beats, Motion signal 456 is an example signal sensed by an accelerometer of the mechanical sensing module 108 of the LCP 100 assuming two consecutive pace initiated heart beats. Motion signals 454, 456 illustrate motion level measurements of the LCP 100. Tracing 458 shows the example motion signals 454 and 456 plotted to show their relative amplitudes over time. The example signal traces in FIG. 5 may be taken using an LCP 100 while the patient is in a relative static position (e.g. little or no patient activity).

Line A-A in FIG. 5 represents a time at which readings from a mechanical sensing module 108 (e.g., from a motion sensor thereof) may be taken. In some cases, a time associated with line A-A may be relative to an identified heart beat in electrical signal 452. In one example, line A-A may be set at a predetermined time after a heart beat has been detected, such as 50 milliseconds (ms), 100 ms, 150 ms, 200 ms, 250 ms, 300 ms, and/or other time period therebetween, greater than 300 ms, or less than 50 ms. In some cases, it may be desirable to consistently take measurements from the mechanical sensing module 108 during one of the systole

and diastole phases of the cardiac cycle. For example, a measurement may be taken from mechanical sensing module 108 while the heart of a patient is in the systole phase (e.g., while the heart is contracting) and the acceleration of the heart may be substantially constant. It one example, taking measurements from the mechanical sensing module 108 at or at about 200 ms after a heart beat is initiated can result in a measurement during a systole phase of the cardiac cycle and while the heart is in substantial constant acceleration (e.g., constant contraction and relatively flat in FIG. 5),

As can be seen from trace 458 in FIG. 5, motion signals 454 and 456 have different values at line A-A. This difference between motions signals 454 and 456 at line A-A may be considered to be a graphical representation of “noise” in the measurements taken from the mechanical sensing module 108 when sequential heart beats are not initiated by the same one of an intrinsic rhythm and a pace rhythm. The techniques herein may be utilized, individually and/or in combination, to help correct for this “noise” when determining whether to modify a pacing therapy in response to a motion level of a patient.

In rate-adaptive pacing, a motion level for an LCP 100 (e.g., an IMD) may be determined for every heart beat. Then, a motion level of a patient (e.g., an activity level) in which the LCP 100 is implanted may be identified by comparing a motion level of the LCP 100 for a current heart beat to one or more motion levels associated with one or more previous heart beats. The difference may be attributed to the activity level of the patient. However, when heart beats transition between heart beats initiated by different rhythms (e.g., an intrinsic rhythm and a pace rhythm), the aforementioned “noise” may occur resulting in larger than expected changes in motion levels of the LCP 100 that may inaccurately indicate a rise in activity level of a patient and unnecessarily raising a pacing rate of the heart.

FIG. 6 depicts an illustrative method 500 for setting a pace rate parameter of an LCP 100 implanted in a patient’s heart based, at least in part, on an identified motion level of the patient. In illustrative method 500, a plurality of heart beats may be identified 502, for example, by the electrical sensing module 106 of the implanted LCP 100. The processing module 110 of the LCP 100, or other processing module (e.g., located at or remote from the LCP), may identify 504 whether the identified heart beats were intrinsically initiated or pace initiated. The processing module 110 may distinguish intrinsically initiated heart beats, pace initiated heart beats and fusion beats by analyzing the morphology of the electrical signal 452 of the heart beat, the morphology of motion signal 454, 456, and/or using any other suitable technique. In some cases, the electrical signal 452 may be compared to an electrical signal template for an intrinsically initiated heart beat, an electrical signal template for a pace initiated heart beats and an electrical signal template for a fusion beat, and to identify which electrical signal template the electrical signal 452 most closely matches. Likewise, the motion signal may be compared to a motion signal template for an intrinsically initiated heart beat, a motion signal template for a pace initiated heart beats and a motion signal template for a fusion beat, and to identify which motion signal template the motion signal most closely matches. These are just examples.

For intrinsically initiated heart beats, the processing module 110 may identify 506 a motion level measurement from the mechanical sensing module 108 (e.g., from a motion sensor thereof) of the LCP 100 (e.g., an IMD) and compare 508 the identified motion level of the LCP 100 for a current

intrinsically initiated heart beat to a motion level of the LCP 100 for one or more previous intrinsically initiated heart beats. The motion level measurement may be taken during the systole phase of the cardiac cycle, but this is not required. Based, at least in part on the comparison, the processing module 110, or other processing module, may identify 510 a motion level of the patient in which the LCP 100 is implanted. Based, at least in part on the identified motion level of the patient, the processing module 110, or other processing module, may set 518 a pacing rate parameter for the LCP 100.

For pace initiated heart beats, the processing module 110 may identify 512 a motion level measurement from the mechanical sensing module 108 for the LCP 100 (e.g., an IMD) and compare 514 the identified motion level of the LCP 100 for a current pace initiated heart beat to a motion level of the LCP 100 for one or more previous pace initiated heart beats. Based, at least in part on the comparison, the processing module 110, or other processing module, may identify 516 a motion level of the patient in which the LCP 100 is implanted. Based, at least in part on the identified motion level of the patient, the processing module 110, or other processing module, may set 518 a pacing rate parameter for the LCP 100.

In some cases, and as discussed above with respect to rate-adaptive pacing, comparing the identified motion level of the LCP 100 for a current heart beat to a motion level of the LCP 100 for a previous heart beat may include determining a difference between the compared motion levels. Then, based on this difference, the processing module 110 of the LCP 100 may set or update the motion level of the patient (e.g. activity level) and thus, set or update a pacing rate parameter for the LCP 100. In one example, the value of the motion level of the patient may be an absolute value of the difference between the motion level corresponding to a current heart beat and the motion level corresponding to the previous heart beat, but other relationships are contemplated. This general process, along with others, for comparing motion levels of the LCP 100 associated with different heart beats and determining a motion level of a patient may be utilized in the various techniques discussed herein.

Alternatively, or in addition to, comparing 508, 514 a motion level of an LCP 100 (e.g., an IMD) for a current heart beat to a motion level of the LCP 100 for an immediately previous heart beat, the processing module 110 may compare the motion level of an LCP 100 for a current heart beat to an average of motion levels of the LCP 100 for N previous heart beats (e.g., two or more previous heart beats) that were initiated by a same rhythm (e.g., intrinsic rhythm or pace rhythm) as is the current heart beat. The average of motion levels of the LCP 100 for N previous heart beats may be a straight average, a weighted average (e.g., where motion levels associated with one or more previous heart beats is weighted greater than another motion level associated with a heart beat), and/or one or more other average of motion levels. In other instances, the motion level of the LCP 100 may be compared to one or more other statistical analyses related to motion levels of the LCP 100 associated with previous heart beats. The comparison may then be used to determine a motion level of a patient and/or used to set a pacing rate for the LCP 100.

The number of N previous heart beats may be determined by a sliding or moving time window that extends back a predetermined amount of time or a predetermined number of beats from a current heart beat. In one example, there may be a predetermined amount of time, t, before the current heart beat and seven (7) heart beats occur during the time t.

Of these seven heart beats, four may be intrinsically initiated heart beats and three may be pace initiated heart beats. Thus, if the current heart beat is an intrinsically initiated heart beat, a motion level associated with the current heart beat may be compared to an average of the four motion levels associated with the four intrinsically initiated heart beats within time t. If the current heart beat is a pace initiated heart beat, a motion level associated with the current heart beat may be compared to an average of the three motion levels associated with the three pace initiated heart beats within time t. A predetermined time t may be any time less than one (1) second, a time between one (1) second and three (3) minutes, a time between one (1) second and two (2) minute, one (1) second and one (1) minute, or any time greater than three (3) minutes.

If no heart beats occurring within the sliding or moving window were initiated by a same rhythm type (e.g., intrinsic or pace) as the current heart beat, then a motion level of the LCP 100 associated with the current heart beat may not be compared to a motion level associated with a heart beat or one or more other actions may be taken. In such instances, a motion level of a patient may not be updated and a pace rate for the LCP 100 may not be updated or re-set in response to the current heart beat.

Although the sliding or moving window is discussed with respect to averaging motion levels associated with previous heart beats initiated in the same manner as a current heart beat, the sliding or moving window may be utilized in other circumstances and/or without averaging motion levels within the window. For example, the processing module 110 may compare a motion level of the LCP 100 to a motion level of the LCP 100 associated with one previous and similarly initiated heart beat within the sliding or moving window. That is, all motion levels associated with previous similarly initiated heart beats outside of the sliding or moving window may be dropped and a motion level associated with a current heart beat may be compared to a motion level associated with the most recent similarly initiated heart beat within the window. Additionally or alternatively, if there are no previous similarly initiated heart beats within the sliding or moving window, a second or further sliding or moving window (e.g., having a longer duration than the first sliding or moving window) may be utilized. In such cases, an average of the motion levels associated with the previous similarly initiated heart beats in the second or further sliding or moving window may be compared to the motion level of the current heart, but this is not required.

In some cases, the LCP 100 may skip setting a pacing rate based, at least in part, on a motion level of the patient associated with a most recent heart beat and instead, maintain the previously established pacing rate for the most recent heart beat. For example, if a most recent heart beat is identified as an intrinsically initiated heart beat or a pace initiated heart beat and is directly after (e.g., immediately after or sequentially follows) a heart beat initiated by the same type of rhythm, then the LCP 100 may set a pacing rate based, at least in part, on a motion level of the patient associated with the most recent heart beat, as discussed with respect to illustrative method 500. However, in the example, if a most recent heart beat is initiated by a different type of rhythm than an immediately previous heart beat, the LCP 100 may maintain the pace rate previously established, and essentially ignore the most recent heart beat.

FIG. 7 depicts an illustrative method 600 for determining whether to update a motion level of a patient (e.g. activity level) based on a current heart beat and thus, update the set pacing rate. Illustrative method 600 may be carried out by

the processing module 110 of the LCP and may be used individually or in combination with the other techniques and processes described herein.

As shown in FIG. 7, illustrative method 600 may include determining 602 whether a currently identified heart beat is initiated by a same one of an intrinsic rhythm or a pace rhythm as was an immediately previous heart beat. If the currently identified heart beat is not initiated by a same one of an intrinsic rhythm or a pace rhythm as was an immediately previous heart beat, then the LCP 100 may skip updating 604 a motion level of the patient for the current heart beat. In some cases, not updating 604 a motion level of the patient may include either not identifying a motion level of the LCP 100 for a current heart beat or ignoring an identified motion level of the LCP 100 for the current heart beat. As a result, a previously set pacing rate for the patient may be maintained 606. In some cases, instead of maintaining 606 a previously set pacing rate for the patient, the processing module 110 may take one or more steps to change the pacing rate based on one or more parameters other than a motion level of the patient.

In illustrative method 600, if the currently identified heart beat is initiated by a same one of an intrinsic rhythm or a pace rhythm as was an immediately previous heart beat, then the LCP 100 may update 608 a motion level of the patient. In one example, a motion level of a patient may be updated by the processing module 110 or other processing module by identifying a motion level of the LCP 100 from the mechanical sensing module 108 (e.g. from accelerometer signal), comparing the identified motion level of the LCP 100 to a motion level of the LCP 100 for the immediately previous heart beat and determining a motion level of the patient based, at least in part, on the comparison, but this is not required and other techniques may be utilized. Once the motion level of the patient has been updated, the LCP 100 may update (e.g., set) 610 a pacing rate based, at least in part, on the updated motion level of the patient.

In some instances, a fusion initiated heart beat may occur. A fusion initiated heart beat is a heart beat in which a pace rhythm and an intrinsic rhythm of the heart occur at the same or close to the same time and cause a fusion heart beat. If a currently identified heart beat is a fusion initiated heart beat, then the LCP 100 may skip updating a motion level of a patient for the current heart beat. In some cases, not updating or identifying a motion level of the patient may include either not identifying a motion level of the LCP 100 for the current heart beat or ignoring an identified motion level of the LCP 100 for the current heart beat. As a result, a previously set pacing rate for the patient may be maintained. In some cases, instead of maintaining a previously set pacing rate for the patient, the processing module 110 may take one or more steps to change the pace rate based on one or more parameters other than a motion level of the patient.

FIG. 8 depicts an illustrative method 700 that may be effected by the processing module 110 of the LCP 100 and may be used individually or in combination with the other techniques and processes described herein. In illustrative method 700, a current heart rate of a patient may be identified 702 and based, at least in part, on the identified heart rate, a current heart beat may be identified 704 as corresponding to a particular heart rate range of two or more heart rate ranges. The heart rate ranges may be determined in any manner. In one example, a first heart rate range may be indicative of a resting activity level for a patient, a second heart rate range may be indicative of an active activity level for the patient (e.g. walking), and a third heart rate range may be indicative of a strenuous activity level of the patient

(e.g. running). Additionally, in sonic cases, the heart beats identified as corresponding to each heart rate range may be further classified as being either intrinsically or pace initiated. For a current heart beat intrinsically initiated or pace initiated, a motion level of an LCP 100 may be identified 706 and the motion level may be compared 708 to a motion level of the LCP 100 for one or more similarly initiated heart beats in the corresponding heart rate range. Then, a motion level of the patient may be identified 710 based, at least in part on the comparison.

In some cases, rather than ignoring a motion level of a current heart beat when the current heart beat is not initiated by the same intrinsic or pace rhythm, it is contemplated that an offset may be applied. The offset may be applied to correct for the "noise" in a motion level measurement taken for the current heart beat that results from the current heart beat not being initiated by the same intrinsic rhythm or pace rhythm than the immediately previous heart beat (e.g., see the offset at line A-A between motion signal 454 and motion signal 456 of FIG. 5). An illustrative method 800 is shown in FIG. 9 for using an offset for determining a motion level of a patient even for heart beats that transition from an intrinsic rhythm to a pace rhythm, and visa-versa.

The illustrative method 800 includes identifying 802 a plurality of heart beats and identifying 804 each of two or more of the identified heart beats as being an intrinsically initiated heart beat or a pace initiated heart beat. The processing module 110 of the LCP 100 may then determine 806 if a current heart beat is initiated by a same one of an intrinsic rhythm or a pace rhythm of the immediately previous heart beat. In illustrative method 800, if a current heart beat is initiated by a same one of an intrinsic rhythm or a pace rhythm of the immediately previous heart beat, the processing module 110 may identify 808 a motion level of the LCP 100 (e.g., an IMD) using a motion sensor (e.g. accelerometer) of the mechanical sensing module 108 and compare 810 the identified motion level of the LCP 100 to a motion level of the LCP 100 corresponding to one or more previous and similarly initiated (e.g., either intrinsically initiated or pace initiated) heart beats. In some cases, and similar to as discussed above, the motion level corresponding to the measurement from the motion sensor of the mechanical sensing module 108 may be taken during the systole phase of a cardiac cycle, but this is not required. Based, at least in part, on the comparison 810, the processing module 110 may identify 812 a motion level of the patient and set 822 a pacing rate parameter for the LCP 100 based, at least in part, on the identified motion level of the patient.

In illustrative method 800, if a current heart beat is initiated by a different one of an intrinsic rhythm or a pace rhythm of the immediately previous heart beat, the processing module 110 may identify 814 a motion level of the LCP 100 (e.g., an IMD) using a motion sensor (e.g. accelerometer) of the mechanical sensing module 108 and apply 816 an offset to the identified motion level. In one example, the offset may represent the offset at line A-A between motion signal 454 and motion signal 456 of FIG. 5. The identified motion level of the LCP 100 for the current heart beat with the offset applied may then be compared 818 to a motion level of the LCP 100 corresponding to the immediately previous heart beat. In some cases, and similar to that discussed above, the motion level corresponding to the measurement from the motion sensor of the mechanical sensing module 108 may be taken during the systole phase of a cardiac cycle, but this is not required. Based, at least in part, on the comparison 818, the processing module 110 may identify 820 a motion level of the patient and set a pacing

rate parameter for the LCP 100 based, at least in part, on the identified motion level of the patient.

One illustrative method for determine the offset is shown in FIG. 10. Illustrative method 900 of FIG. 10 may be utilized to determine the offset to be applied to a motion level of a current heart beat on a transition from a heart beat that was initiated by a different rhythm (e.g., an intrinsic rhythm or a pace rhythm). To determine the offset, the processing module 110 of the LCP 100 or other processing module may identify 902 a calibration window. In some cases, the calibration window may cover a time period or window in which N pace initiated heart beats occur and in which N intrinsically initiated heart beats occur. The illustrative method 900 may include identifying 904 a motion level of the LCP 100 (e.g., an IMD) for N pace initiated heart beats using a motion sensor of the mechanical sensing module 108 and identifying 906 a motion level of the LCP 100 for N intrinsically initiated heart beats using the motion sensor of the mechanical sensing module 108. N may be one, two, or a greater number of heart beats. The N heart beats for a particular rhythm type (e.g., intrinsic or pace) may be consecutive heart beats or may be separated by one or more heart beats initiated by the other rhythm type. In some cases, to obtain N consecutive pace initiated heart beats, it may be necessary to raise the pacing rate to a particular level above a current intrinsic heart rate (e.g., 5-30 beats per minute over the current intrinsic heart rate, 10-20 beats per minute over the current intrinsic heart rate, and/or a different level above the current intrinsic heart rate). In some cases, to obtain N consecutive intrinsically initiated heart beats, it may be necessary to lower the pacing rate to a particular level below a current intrinsic heart rate (e.g., 5-10 beats per minute below the current intrinsic heart rate and/or a different level below the current intrinsic heart rate). In some cases, the measurements taken by the motion sensor of the mechanical sensing module 108 for each of the N heart beats may be taken during the systole phase of the cardiac cycle, but this is not required.

From the identified motion levels for the N pace initiated heart beats, the processing module 110 may identify a baseline pace motion level. Similarly, from the identified motion levels for the N intrinsically initiated heart beats, the processing module 110 may identify a baseline intrinsic motion level. Based, at least in part, on the baseline pace motion level and the baseline intrinsic motion level, the processing module 110 may determine an offset that may be applied to motion levels associated with heart beats initiated by a rhythm that is different than a rhythm that initiated an immediately previous heart beat.

The baseline pace motion level and/or the baseline intrinsic motion level may be identified in any manner. In one example, the motion levels of the LCP 100 associated with the N pace initiated heart beats may be averaged to obtain the baseline pace motion level. Similarly, in an example, the motion levels of the LCP 100 associated with the N intrinsic initiated heart beats may be averaged to obtain the baseline intrinsic motion level. In addition or as an alternative to averaging of the motion levels associated with the heart beats, other analyses may be performed on the identified motion levels. For example, motion levels detected for older heart beats may be weighted less than the motion levels detected of more recently heart beats.

FIGS. 11A-11C show graphs 960a, 960b, 960c, which represent an average of motion level signals from different axes, x-axis, y-axis, and z-axis, respectively, generated by a motion sensor, such as a three-axis accelerometer, of LCP 100 for each of N pace initiated heart beats and N intrinsic-

cally initiated heart beats, where LCP 100 is attached to a wall of a patient's heart. Signal 962, shown in a dashed line in graphs 960a-960c, represents an average of accelerometer magnitude signals (e.g., a baseline motion level signal) for N pace initiated heart beats on the respective axis. Signal 964, represented in a solid line, represents an average of accelerometer magnitude signals (e.g., a baseline motion level signal) for N intrinsically initiated heart beats.

In the example depicted in FIGS. 11A-11C, an offset may be selected by determining a difference between signal 962 and 964 at a predetermined time in each graph and using the greatest difference at the predetermined time as the offset. Alternatively, the least difference at the predetermined time may be utilized as the offset. Alternatively, the difference of each axis may be averaged to determine the offset. In yet another example, one or more other analyses may be performed to determine the offset. As shown in the example of FIGS. 11A-11C, a pre-determined time may be 200 ms, at line A-A, after a heart beat has been identified. In the example, at 200 ms, the signals 962 and 964 have a difference of 175 units on the x-axis (FIG. 11A), 125 units on the y-axis (FIG. 11B), and 125 units on the z-axis (FIG. 11C). With this example, the processing module 110 or other module may select the difference of the x-axis as the offset because it is the greatest difference between signals 962 and 964 at 200 ms out from when a heart beat was initiated.

The calibration window discussed above may be identified in accordance with a predetermined time period and may begin in response to a signal from a device external to the LCP 100 or other signal. Alternatively, or in addition, a calibration window may be identified by the LCP 100 or other device after N consecutive pace initiated heart beats and/or after N consecutive intrinsically initiated heart beats, where N may be the same number or a different number of pace initiated heart beats and intrinsically initiated heart beats.

In some cases, a calibration window may be selected based on a patient activity level. In one example, a calibration window may be selected to occur while a patient in which the LCP 100 is implanted is performing no activity or is at a low activity level. Illustratively, no activity or a low activity level may include the patient sitting down, lying down, in a standing position, in a particular pose, and/or in one or more static or substantially static position.

In some cases, a calibration window may be automatically initiated to start an offset determination process (e.g., such as method 900). For example, the LCP 100 may detect when the patient is in a particular position or posture and may automatically initiate a calibration window. In some cases, the LCP 100 may detect that a motion level or activity level of the patient has crossed (e.g., fallen below or exceeded) a threshold level of motion or activity for a predetermined length of time, and then initiate a calibration window. Further, and in some cases, the LCP 100 may only automatically initiate a calibration window if it detects communication with an external device in addition to detecting that the patient is in a particular position or posture, but this is not required. Alternatively or additionally, the LCP 100 may only automatically initiate a calibration window if it detects a certain time of day. Such automatic initiation of a calibration window may allow the LCP 100 to update the offset over time to account for changing conditions.

In some cases, the LCP 100 may be configured to detect one or more positions or postures (e.g., N positions or postures) of a patient in which the LCP 100 has been implanted. This may allow the LCP 100 to: 1) create a library of offsets for different positions or postures of the

patient; and 2) apply the offsets for different positions or postures when the patient is in a corresponding position or posture. For each posture or position of the patient, the processing module 110 or other processing module may identify a calibration window. During each calibration window, the processing module 110 or other processing module may identify a motion level of the LCP 100 (e.g., an IMD) using a motion sensor of the mechanical sensing module 108 for N intrinsically initiated heart beats and identify a motion level of the LCP 100 using the motion sensor for N pace initiated heart beats, where the respective N heart beats may be two or more heart beats and may or may not be consecutive heart beats. Further, measurements from the motion sensor may be taken during the systole phase of the cardiac cycle, but this is not required.

Based on the identified motion levels of the LCP 100 for the pace initiated heart beats, the processing module 110 or other processing module may identify a baseline pace motion level for the identified patient posture or position. Similarly, based on the identified motion levels of the LCP 100 for the intrinsic initiated heart beats, the processing module 110 or other processing module may identify a baseline intrinsic motion level for the identified patient posture or position. Then, in a manner similar to as discussed above with respect to method 900, the processing module may determine an offset for the identified posture or position of the patient based, at least in part, on the baseline intrinsic motion level and the baseline pace motion level for the identified posture or position.

The offsets corresponding to the various patient postures or positions may then be saved in a library in memory of the LCP 100 (e.g., memory of the processing module 110 or other memory) and/or in memory external to the LCP 100. Then, when a heart beat that is initiated by a different rhythm (e.g., intrinsic rhythm or pace rhythm) than an immediately previous rhythm is identified, the LCP 100 may identify the patient's posture or position and apply a posture or position specific offset to the motion level of an LCP 100 for the current heart beat prior to or after comparing the motion level to a motion level of the LCP 100 for the immediately previous heart beat.

Those skilled in the art will recognize that the present disclosure may be manifested in a variety of forms other than the specific embodiments described and contemplated herein. For instance, as described herein, various embodiments include one or more modules described as performing various functions. However, other embodiments may include additional modules that split the described functions up over more modules than that described herein. Additionally, other embodiments may consolidate the described functions into fewer modules.

Although various features may have been described with respect to less than all embodiments, this disclosure contemplates that those features may be included on any embodiment. Further, although the embodiments described herein may have omitted some combinations of the various described features, this disclosure contemplates embodiments that include any combination of each described feature. Accordingly, departure in form and detail may be made without departing from the scope and spirit of the present disclosure as described in the appended claims.

What is claimed is:

1. An implantable medical device (IMD) implantable within a patient's heart, the IMD comprising:
 - two or more sensors including a motion sensor;
 - a controller operatively coupled to the two or more sensors, the controller configured to:

identify a plurality of heart beats using one or more of the sensors, each of the plurality of heart beats having a systole phase and diastole phase;
 identify each of two or more of the plurality of heart beats as an intrinsically initiated heart beat or a pace initiated heart beat;
 identify a calibration time window, and during the calibration time window:
 identify a baseline intrinsic motion level by identifying a motion level of the IMD using the motion sensor during N intrinsically initiated heart beats, where N is greater than two;
 identify a baseline pace motion level by identifying a motion level of the IMD using the motion sensor during N pace initiated heart beats, where N is greater than two;
 determine an offset based at least in part on the baseline intrinsic motion level and the baseline pace motion level;
 after the calibration time window:
 for an intrinsically initiated heart beat that immediately follows a pace initiated heart beat, identify a motion level of the IMD using the motion sensor and apply the offset, and compare the identified motion level of the IMD with the applied offset to a motion level of the IMD identified for the immediately preceding pace initiated heart beat, and identify a motion level of the patient based at least in part on the comparison; and
 set a pacing rate parameter based at least in part on the identified motion level of the patient.

2. The IMD of claim 1, wherein, after the calibration time window, the controller is further configured to:
 for a pace initiated heart beat that immediately follows an intrinsically initiated heart beat, identify a motion level of the IMD using the motion sensor and apply the offset, and compare the identified motion level of the IMD with the applied offset to a motion level of the IMD identified for the immediately preceding intrinsically initiated heart beat, and identify a motion level of the patient based at least in part on the comparison.

3. The IMD of claim 2, wherein, after the calibration time window, the controller is further configured to:
 for an intrinsically initiated heart beat that immediately follows an intrinsically initiated heart beat, identify a motion level of the IMD using the motion sensor during the systole phase of the intrinsically initiated heart beat, and compare the identified motion level of the IMD to a motion level of the IMD identified for one or more previous intrinsically initiated heart beats, and identify a motion level of the patient based at least in part on the comparison.

4. The IMD of claim 3, wherein, after the calibration time window, the controller is further configured to:
 for a pace initiated heart beat that immediately follows a pace initiated heart beat, identify a motion level of the IMD using the motion sensor during the systole phase of the pace initiated heart beat, and compare the identified motion level of the IMD to a motion level of the IMD identified for one or more previous pace initiated heart beats, and identify the motion level of the patient based at least in part on the comparison.

5. The IMD of claim 1, wherein the N intrinsically initiated heart beats are N consecutive intrinsically initiated heart beats.

6. The IMD of claim 1, wherein the N pace initiated heart beats are N consecutive pace initiated heart beats.

7. The IMD of claim 1, wherein the calibration time window is a time window where patient activity is expected to be low.

8. The IMD of claim 1, wherein the calibration time window is initiated after a particular posture of the patient is detected by the IMD.

9. The IMD of claim 8, wherein the IMD is configured to detect each of N different postures, wherein N is greater than two, and wherein the controller is configured to:
 identify a calibration time window for each N different postures, and during each calibration time window:
 identify a baseline intrinsic motion level for the corresponding posture by identifying a motion level of the IMD using the motion sensor during the systole phase of N intrinsically initiated heart beats, where N is greater than two;
 identify a baseline pace motion level for the corresponding posture by identifying a motion level of the IMD using the motion sensor during the systole phase of N pace initiated heart beats, where N is greater than two;
 determine an offset for each of the N different postures based at least in part on the baseline intrinsic motion level that corresponds to the corresponding posture and the baseline pace motion level that corresponds to the corresponding posture;
 after the calibration time window for each of the N different postures:
 identify a current posture of the patient as one of the N different postures;
 for an intrinsically initiated heart beat that immediately follows a pace initiated heart beat, identify a motion level of the IMD using the motion sensor during the systole phase of the intrinsically initiated heart beat and apply the offset that corresponds to the current posture, and compare the identified motion level of the IMD with the applied offset that corresponds to the current posture to a motion level of the IMD identified for the immediately preceding pace initiated heart beat, and identify a motion level of the patient based at least in part on the comparison.

10. The IMD of claim 1, wherein the calibration time window is initiated at a particular time of day.

11. The IMD of claim 1, wherein the calibration time window is initiated after the motion level of the patient falls below a threshold for at least a predetermined length of time.

12. The IMD of claim 1, wherein the controller is further configured to:
 during the calibration time window:
 pace the patient's heart at a pacing rate that is above a current intrinsic heart rate of the patient; and
 while pacing the patient's heart at the pacing rate that is above the current intrinsic heart rate of the patient, identify the baseline pace motion level by identifying the motion level of the IMD using the motion sensor during the systole phase of N pace initiated heart beats, where N is greater than two.

13. A method for identifying an activity level of a patient using a motion sensor implanted within the patient's heart, the method comprising:
 identifying a plurality of heart beats using the motion sensor, each of the plurality of heart beats having a systole phase and diastole phase;
 identifying each of two or more of the plurality of heart beats as an intrinsically initiated heart beat or a pace initiated heart beat;

identifying a calibration time window, and during the calibration time window:

identifying a baseline intrinsic motion level by identifying a motion level of the IMD using the motion sensor during N intrinsically initiated heart beats, where N is greater than two;

identifying a baseline pace motion level by identifying a motion level of the IMD using the motion sensor during N pace initiated heart beats, where N is greater than two;

determining an offset based at least in part on the baseline intrinsic motion level and the baseline pace motion level; and

after the calibration time window:

for an intrinsically initiated heart beat that immediately follows a pace initiated heart beat, identifying a motion level of the IMD using the motion sensor and apply the offset, and comparing the identified motion level of the IMD with the applied offset to a motion level of the IMD identified for the immediately preceding pace initiated heart beat, and identifying a motion level of the patient based at least in part on the comparison.

14. The method of claim **13** further comprising setting a pacing rate parameter based at least in part on the identified motion level of the patient.

15. The method of claim **13**, wherein, after the calibration time window, the method further comprises:

for a pace initiated heart beat that immediately follows an intrinsic initiated heart beat, identifying a motion level of the IMD using the motion sensor and apply the offset, and comparing the identified motion level of the IMD with the applied offset to a motion level of the IMD identified for the immediately preceding intrinsically initiated heart beat, and identifying a motion level of the patient based at least in part on the comparison.

16. The method of claim **13**, wherein, after the calibration time window, the method further comprises:

for an intrinsically initiated heart beat that immediately follows an intrinsically initiated heart beat, identifying a motion level of the IMD using the motion sensor during the systole phase of the intrinsically initiated heart beat, and comparing the identified motion level of the IMD to a motion level of the IMD identified for one or more previous intrinsically initiated heart beats, and identifying a motion level of the patient based at least in part on the comparison; and

for a pace initiated heart beat that immediately follows a pace initiated heart beat, identifying a motion level of the IMD using the motion sensor during the systole phase of the pace initiated heart beat, and comparing the identified motion level of the IMD to a motion level of the IMD identified for one or more previous pace initiated heart beats, and identifying the motion level of the patient based at least in part on the comparison.

17. The method of claim **13**, wherein the N intrinsically initiated heart beats are N consecutive intrinsically initiated heart beats, and wherein the N pace initiated heart beats are N consecutive pace initiated heart beats.

18. A leadless cardiac pacemaker (LCP) implantable within a patient's heart, the LCP comprising:

a housing;

two or more electrodes secured relative to the housing, the two or more electrodes are configured to sense electrical signals of the patient's heart;

an accelerometer situated inside of the housing;

circuitry situated inside of the housing and operatively coupled to the two or more electrodes and the accelerometer, the circuitry is configured to:

identify a plurality of heart beats using two or more of the electrodes, each of the plurality of heart beats having a systole phase and diastole phase;

identify each of two or more of the plurality of heart beats as an intrinsically initiated heart beat or a pace initiated heart beat;

identify a calibration time window, and during the calibration time window:

identify a baseline intrinsic motion level by identifying a motion level of the LCP using the accelerometer during the systole phase of N intrinsically initiated heart beats, where N is greater than two;

identify a baseline pace motion level by identifying a motion level of the LCP using the accelerometer during the systole phase of N pace initiated heart beats, where N is greater than two;

identify an offset based at least in part on the baseline intrinsic motion level and the baseline pace motion level;

after the calibration time window:

for an intrinsically initiated heart beat that immediately follows a pace initiated heart beat, identify a motion level of the LCP using the accelerometer during the systole phase of the intrinsically initiated heart beat and apply the offset, and compare the identified motion level of the LCP with the applied offset to a motion level of the LCP identified for the immediately preceding pace initiated heart beat, and identify a motion level of the patient based at least in part on the comparison;

for a pace initiated heart beat that immediately follows an intrinsic initiated heart beat, identify a motion level of the LCP using the accelerometer during the systole phase of the pace initiated heart beat and apply the offset, and compare the identified motion level of the LCP with the applied offset to a motion level of the LCP identified for the immediately preceding intrinsically initiated heart beat, and identify a motion level of the patient based at least in part on the comparison;

for an intrinsically initiated heart beat that immediately follows an intrinsically initiated heart beat, identify a motion level of the LCP using the accelerometer during the systole phase of the intrinsically initiated heart beat, and compare the identified motion level of the LCP to a motion level of the LCP identified for one or more previous intrinsically initiated heart beats, and identify a motion level of the patient based at least in part on the comparison;

for a pace initiated heart beat that immediately follows a pace initiated heart beat, identify a motion level of the LCP using the accelerometer during the systole phase of the pace initiated heart beat, and compare the identified motion level of the LCP to a motion level of the LCP identified for one or more previous pace initiated heart beats, and identify the motion level of the patient based at least in part on the comparison; and

set a pacing rate parameter based at least in part on the identified motion level of the patient.

19. The LCP of claim **18**, wherein the N intrinsically initiated heart beats are N consecutive intrinsically initiated

31

heart beats, and wherein the N pace initiated heart beats are N consecutive pace initiated heart beats.

20. The LCP of claim **18**, wherein the calibration time window is a time window where patient activity is expected to be low.

5

* * * * *

32

专利名称(译)	活动水平调整的系统和方法		
公开(公告)号	US10617874	公开(公告)日	2020-04-14
申请号	US15/797797	申请日	2017-10-30
[标]申请(专利权)人(译)	心脏起搏器股份公司		
申请(专利权)人(译)	心脏起搏器, INC.		
当前申请(专利权)人(译)	心脏起搏器, INC.		
[标]发明人	KANE MICHAEL J HUELSKAMP PAUL		
发明人	KANE, MICHAEL J. HUELSKAMP, PAUL		
IPC分类号	A61N1/365 A61N1/375 A61B5/11 A61B5/00 A61N1/372		
CPC分类号	A61B5/686 A61B5/7217 A61B5/1116 A61N1/3756 A61N1/37512 A61N1/37288 A61N1/36542 A61B5/1118 A61N1/36535 A61B2560/0223 A61B2562/0219		
优先权	62/424876 2016-11-21 US 62/415132 2016-10-31 US		
其他公开文献	US20180117338A1		
外部链接	Espacenet		

摘要(译)

公开了用于对患者的心脏起搏的系统, 设备和方法。说明性方法可以包括: 使用相对于患者心脏固定的可植入医疗设备的运动传感器来确定患者的运动水平; 以及至少部分地基于患者的运动水平来设置起搏速率。可以通过例如将当前心跳期间由运动传感器感测到的运动水平与与一个或多个先前心跳相关联的运动水平进行比较来确定患者的运动水平。在那些内在引发的心跳和步伐引发的心跳之间过渡的心跳期间, 运动水平测量中可能会出现噪声。可以将各种技术应用于运动水平测量以帮助减少这种噪声的影响。

