



US 20180177423A1

(19) **United States**

(12) **Patent Application Publication**  
**Bishay et al.**

(10) **Pub. No.: US 2018/0177423 A1**  
(43) **Pub. Date: Jun. 28, 2018**

(54) **ELECTROCARDIOGRAPHY PATCH**

*A61B 5/0205* (2006.01)

(71) Applicant: **Bardy Diagnostics, Inc.**, Seattle, WA  
(US)

*A61B 5/087* (2006.01)

*A61B 5/08* (2006.01)

*A61B 5/021* (2006.01)

*A61B 5/091* (2006.01)

*A61B 5/145* (2006.01)

(72) Inventors: **Jon Mikalson Bishay**, Seattle, WA  
(US); **Gust H. Bardy**, Carnation, WA  
(US); **Jason Felix**, Vashon Island, WA  
(US)

(52) **U.S. Cl.**

CPC ..... *A61B 5/04085* (2013.01); *A61B 5/6823*

(2013.01); *A61B 5/04087* (2013.01); *A61B*

*5/02055* (2013.01); *A61B 5/6833* (2013.01);

*A61B 5/087* (2013.01); *A61B 5/14532*

(2013.01); *A61B 5/021* (2013.01); *A61B 5/091*

(2013.01); *A61B 5/14542* (2013.01); *A61B*

*2560/0412* (2013.01); *A61B 2562/164*

(2013.01); *A61B 5/0816* (2013.01)

(21) Appl. No.: **15/905,715**

(22) Filed: **Feb. 26, 2018**

**Related U.S. Application Data**

(63) Continuation of application No. 15/406,627, filed on Jan. 13, 2017, now Pat. No. 9,901,274, which is a continuation of application No. 14/080,717, filed on Nov. 14, 2013, now Pat. No. 9,545,204.

(60) Provisional application No. 61/882,403, filed on Sep. 25, 2013.

**Publication Classification**

(51) **Int. Cl.**

*A61B 5/0408* (2006.01)

*A61B 5/00* (2006.01)

(57)

**ABSTRACT**

An electrocardiography patch is provided. A pair of electrodes are exposed on a contact surface of a flexible backing. A circuit includes a pair of circuit traces and each circuit trace is electrically coupled to one of the electrodes in the pair. A plurality of electrical pads are positioned between the electrodes and above at least a portion of the circuit traces. A pair of the electrical pads interface with the electrodes. A pair of battery leads electrically interface a battery to another pair of the electrical pads.

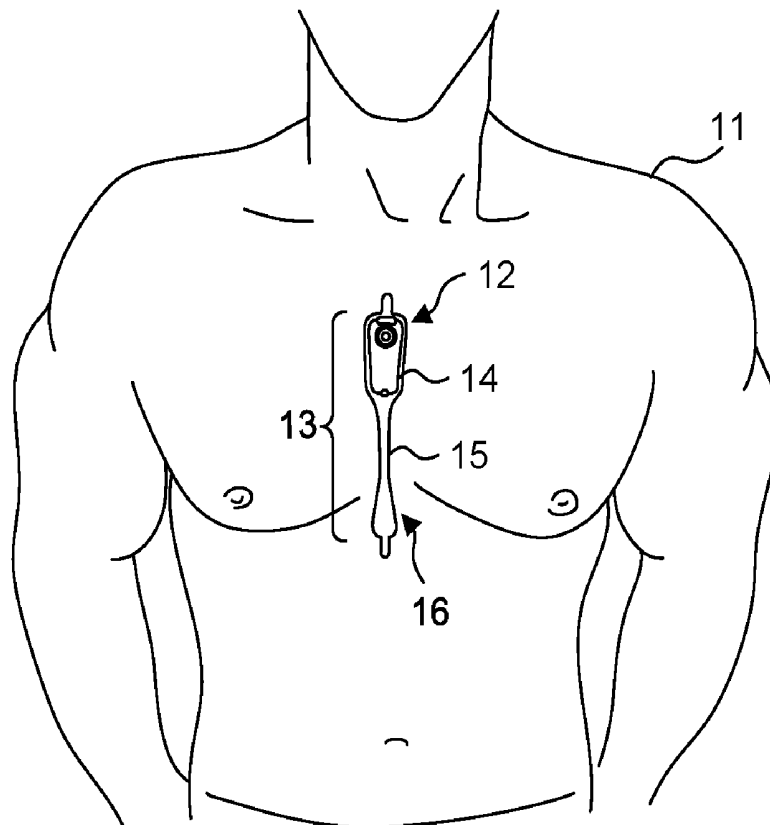

**Fig. 1.**

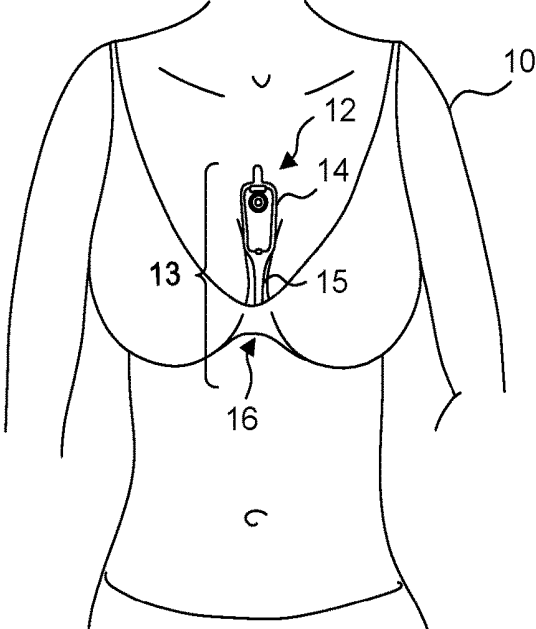

**Fig. 2.**

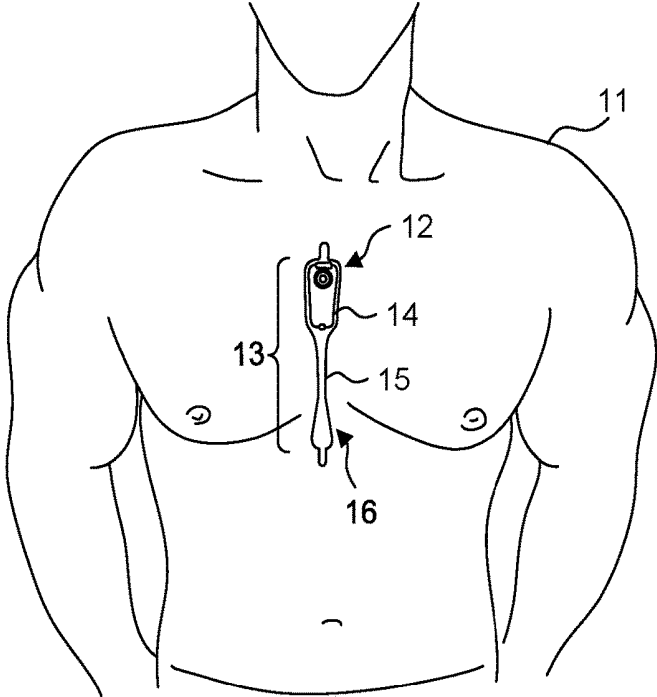

Fig. 3.

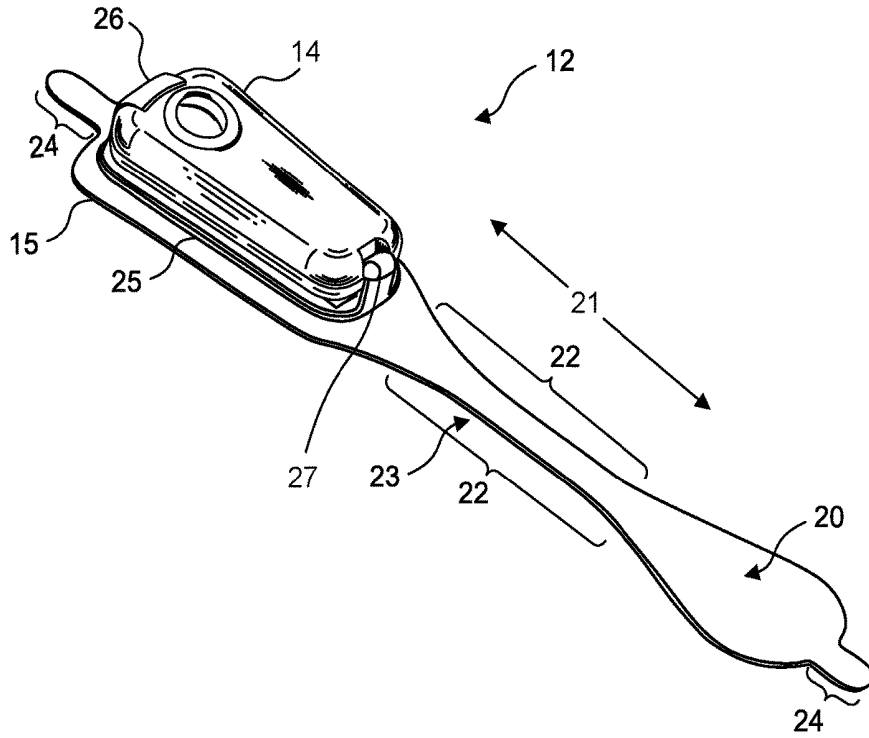

Fig. 4.

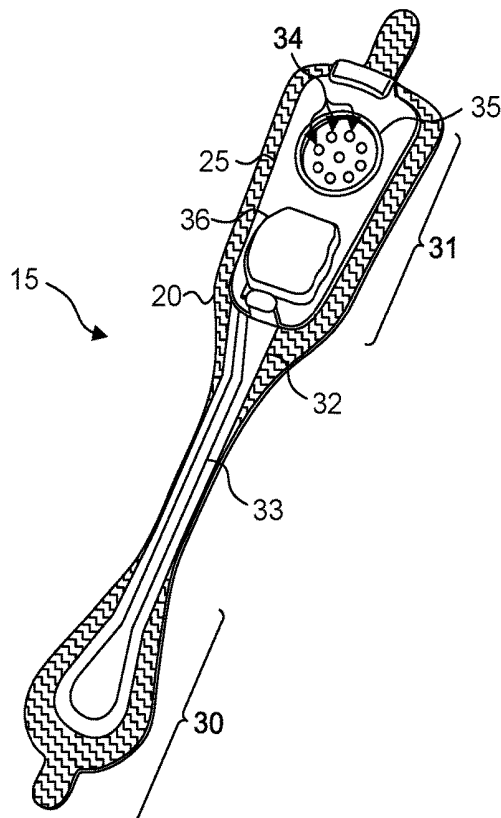

Fig. 5.

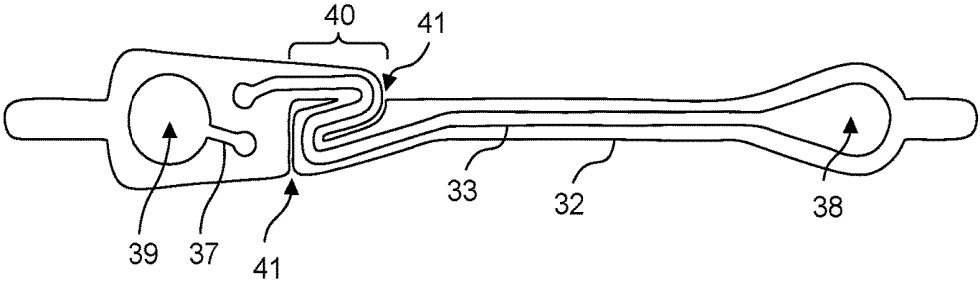

Fig. 6.

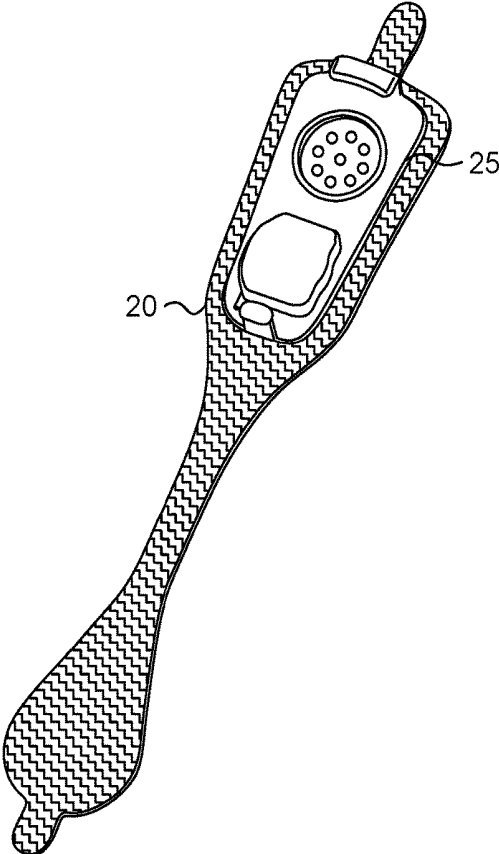

Fig. 7.

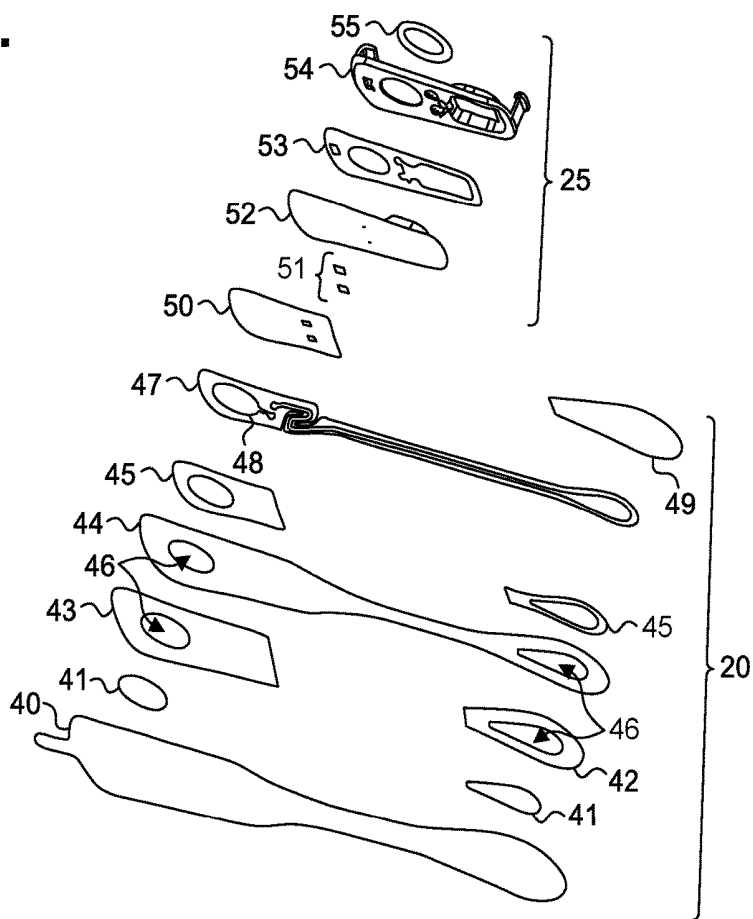
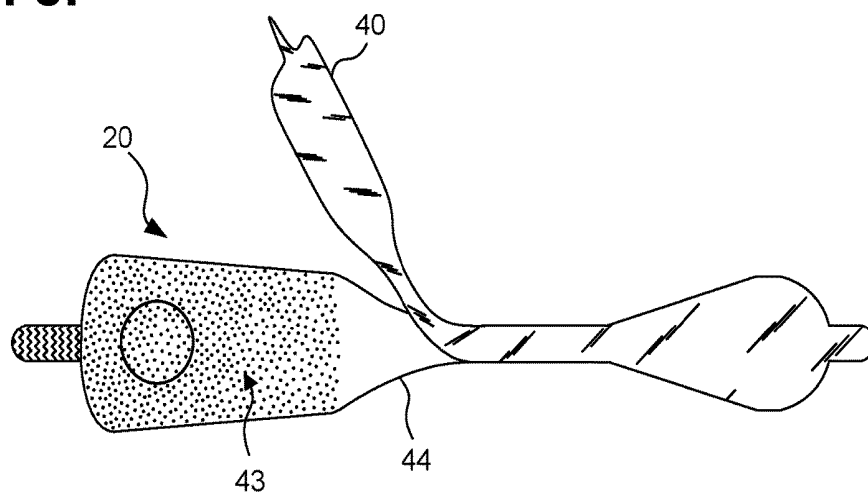

Fig. 8.



## ELECTROCARDIOGRAPHY PATCH

### CROSS-REFERENCE TO RELATED APPLICATION

**[0001]** This U.S. patent application is a continuation of U.S. patent application Ser. No. 15/406,627, filed on Jan. 13, 2017, pending, which is a continuation of U.S. Pat. No. 9,545,204, issued Jan. 17, 2017, which claims priority under 35 U.S.C. § 119(e) to U.S. Provisional patent application, Ser. No. 61/882,403, filed Sep. 25, 2013, the disclosure of which is incorporated by reference.

### FIELD

**[0002]** This application relates in general to electrocardiographic monitoring and, in particular, to an electrocardiography patch.

### BACKGROUND

**[0003]** The heart emits electrical signals as a by-product of the propagation of the action potentials that trigger depolarization of heart fibers. An electrocardiogram (ECG) measures and records such electrical potentials to visually depict the electrical activity of the heart over time. Conventionally, a standardized set format 12-lead configuration is used by an ECG machine to record cardiac electrical signals from well-established traditional chest locations. Electrodes at the end of each lead are placed on the skin over the anterior thoracic region of the patient's body to the lower right and to the lower left of the sternum, on the left anterior chest, and on the limbs. Sensed cardiac electrical activity is represented by PQRSTU waveforms that can be interpreted post-ECG recordation to derive heart rate and physiology. The P-wave represents atrial electrical activity. The QRSTU components represent ventricular electrical activity.

**[0004]** An ECG is a tool used by physicians to diagnose heart problems and other potential health concerns. An ECG is a snapshot of heart function, typically recorded over 12 seconds, that can help diagnose rate and regularity of heartbeats, effect of drugs or cardiac devices, including pacemakers and implantable cardioverter-defibrillators (ICDs), and whether a patient has heart disease. ECGs are used in-clinic during appointments, and, as a result, are limited to recording only those heart-related aspects present at the time of recording. Sporadic conditions that may not show up during a spot ECG recording require other means to diagnose them. These disorders include fainting or syncope; rhythm disorders, such as tachyarrhythmias and bradyarrhythmias; apneic episodes; and other cardiac and related disorders. Thus, an ECG only provides a partial picture and can be insufficient for complete patient diagnosis of many cardiac disorders.

**[0005]** Diagnostic efficacy can be improved, when appropriate, through the use of long-term extended ECG monitoring. Recording sufficient ECG and related physiology over an extended period is challenging, and often essential to enabling a physician to identify events of potential concern. A 30-day observation day period is considered the "gold standard" of ECG monitoring, yet achieving a 30-day observation day period has proven unworkable because such ECG monitoring systems are arduous to employ, cumbersome to the patient, and excessively costly. Ambulatory monitoring in-clinic is implausible and impracticable. Nevertheless, if a patient's ECG could be recorded in an

ambulatory setting, thereby allowing the patient to engage in activities of daily living, the chances of acquiring meaningful information and capturing an abnormal event while the patient is engaged in normal activities becomes more likely to be achieved.

**[0006]** For instance, the long-term wear of ECG electrodes is complicated by skin irritation and the inability ECG electrodes to maintain continual skin contact after a day or two. Moreover, time, dirt, moisture, and other environmental contaminants, as well as perspiration, skin oil, and dead skin cells from the patient's body, can get between an ECG electrode, the non-conductive adhesive used to adhere the ECG electrode, and the skin's surface. All of these factors adversely affect electrode adhesion and the quality of cardiac signal recordings. Furthermore, the physical movements of the patient and their clothing impart various compressional, tensile, and torsional forces on the contact point of an ECG electrode, especially over long recording times, and an inflexibly fastened ECG electrode will be prone to becoming dislodged. Moreover, dislodgment may occur unbeknownst to the patient, making the ECG recordings worthless. Further, some patients may have skin that is susceptible to itching or irritation, and the wearing of ECG electrodes can aggravate such skin conditions. Thus, a patient may want or need to periodically remove or replace ECG electrodes during a long-term ECG monitoring period, whether to replace a dislodged electrode, reestablish better adhesion, alleviate itching or irritation, allow for cleansing of the skin, allow for showering and exercise, or for other purpose. Such replacement or slight alteration in electrode location actually facilitates the goal of recording the ECG signal for long periods of time.

**[0007]** Conventionally, Holter monitors are widely used for long-term extended ECG monitoring. Typically, they are often used for only 24-48 hours. A typical Holter monitor is a wearable and portable version of an ECG that include cables for each electrode placed on the skin and a separate battery-powered ECG recorder. The cable and electrode combination (or leads) are placed in the anterior thoracic region in a manner similar to what is done with an in-clinic standard ECG machine. The duration of a Holter monitoring recording depends on the sensing and storage capabilities of the monitor, as well as battery life. A "looping" Holter (or event) monitor can operate for a longer period of time by overwriting older ECG tracings, thence "recycling" storage in favor of extended operation, yet at the risk of losing event data. Although capable of extended ECG monitoring, Holter monitors are cumbersome, expensive and typically only available by medical prescription, which limits their usability. Further, the skill required to properly place the electrodes on the patient's chest hinders or precludes a patient from replacing or removing the precordial leads and usually involves moving the patient from the physician office to a specialized center within the hospital or clinic.

**[0008]** The ZIO XT Patch and ZIO Event Card devices, manufactured by iRhythm Tech., Inc., San Francisco, Calif., are wearable stick-on monitoring devices that are typically worn on the upper left pectoral region to respectively provide continuous and looping ECG recording. The location is used to simulate surgically implanted monitors. Both of these devices are prescription-only and for single patient use. The ZIO XT Patch device is limited to a 14-day monitoring period, while the electrodes only of the ZIO Event Card device can be worn for up to 30 days. The ZIO

XT Patch device combines both electronic recordation components and physical electrodes into a unitary assembly that adheres to the patient's skin. The ZIO XT Patch device uses adhesive sufficiently strong to support the weight of both the monitor and the electrodes over an extended period of time and to resist disadherence from the patient's body, albeit at the cost of disallowing removal or relocation during the monitoring period. The ZIO Event Card device is a form of downsized Holter monitor with a recorder component that must be removed temporarily during baths or other activities that could damage the non-waterproof electronics. Both devices represent compromises between length of wear and quality of ECG monitoring, especially with respect to ease of long term use, female-friendly fit, and quality of atrial (P-wave) signals.

**[0009]** Therefore, a need remains for an extended wear continuously recording ECG monitor practicably capable of being worn for a long period of time, especially in women where breast anatomy can interfere with signal quality in both men and women and capable of recording atrial signals reliably.

**[0010]** A further need remains for a device capable of recording signals ideal for arrhythmia discrimination, especially a device designed for atrial activity recording.

#### SUMMARY

**[0011]** Physiological monitoring can be provided through a wearable monitor that includes two components, a flexible extended wear electrode patch and a removable reusable monitor recorder. The wearable monitor sits centrally (in the midline) on the patient's chest along the sternum oriented top-to-bottom. The placement of the wearable monitor in a location at the sternal midline (or immediately to either side of the sternum), with its unique narrow "hourglass"-like shape, significantly improves the ability of the wearable monitor to cutaneously sense cardiac electric signals, particularly the P-wave (or atrial activity) and, to a lesser extent, the QRS interval signals in the ECG waveforms indicating ventricular activity. The electrode patch is shaped to fit comfortably and conformal to the contours of the patient's chest approximately centered on the sternal midline. To counter the dislodgment due to compressional and torsional forces, a layer of non-irritating adhesive, such as hydrocolloid, is provided at least partially on the underside, or contact, surface of the electrode patch, but only on the electrode patch's distal and proximal ends. To counter dislodgment due to tensile and torsional forces, a strain relief is defined in the electrode patch's flexible circuit using cutouts partially extending transversely from each opposite side of the flexible circuit and continuing longitudinally towards each other to define in 'S'-shaped pattern. Each of these components are distinctive and allow for comfortable and extended wear, especially by women, where breast mobility would otherwise interfere with monitor use and comfort.

**[0012]** One embodiment provides an extended wear electrocardiography patch. A flexible backing is formed of an elongated strip of stretchable material with a narrow longitudinal midsection evenly tapering inward from both ends. The elongated strip is adherable only on each end of a contact surface to serve as a crimp relief to facilitate compression of the narrow longitudinal midsection in response to compressional and torsional forces. A pair of electrocardiographic electrodes is respectively affixed to and

conductively exposed on the contact surface of each end of the elongated strip. A flexible circuit is affixed on each end to the elongated strip. The flexible circuit includes a pair of circuit traces both originating within one of the ends of the elongated strip and which are electrically coupled to each electrocardiographic electrode. A laterally-extendable strain relief is defined in the flexible circuit and formed to facilitate extension and rotation of the flexible circuit in response to tensile and torsional forces. A non-conductive receptacle is securely adhered on the one end of the elongated strip opposite the contact surface and is formed to removably receive an electrocardiography monitor. The non-conductive receptacle includes electrode terminals aligned to electrically interface the pair of circuit traces to the electrocardiography monitor.

**[0013]** A further embodiment provides an electrocardiography patch. A pair of electrodes are exposed on a contact surface of a flexible backing. A circuit includes a pair of circuit traces and each circuit trace is electrically coupled to one of the electrodes in the pair. A plurality of electrical pads are positioned between the electrodes and above at least a portion of the circuit traces. A pair of the electrical pads interface with the electrodes. A pair of battery leads electrically interface a battery to another pair of the electrical pads.

**[0014]** The monitoring patch is especially suited to the female anatomy. The narrow longitudinal midsection can fit nicely within the intermammary cleft of the breasts without inducing discomfort, whereas conventional patch electrodes are wide and, if adhered between the breasts, would cause chafing, irritation, frustration, and annoyance, leading to low patient compliance.

**[0015]** The foregoing aspects enhance ECG monitoring performance and quality facilitating long-term ECG recording, critical to accurate arrhythmia diagnosis. In addition, the foregoing aspects enhance comfort in women (and certain men), but not irritation of the breasts, by placing the monitoring patch in the best location possible for optimizing the recording of cardiac signals from the atrium, another feature critical to proper arrhythmia diagnosis.

**[0016]** Still other embodiments will become readily apparent to those skilled in the art from the following detailed description, wherein are described embodiments by way of illustrating the best mode contemplated. As will be realized, other and different embodiments are possible and the embodiments' several details are capable of modifications in various obvious respects, all without departing from their spirit and the scope. Accordingly, the drawings and detailed description are to be regarded as illustrative in nature and not as restrictive.

#### BRIEF DESCRIPTION OF THE DRAWINGS

**[0017]** FIGS. 1 and 2 are diagrams showing, by way of examples, an extended wear electrocardiography monitor, including an extended wear electrode patch in accordance with one embodiment, respectively fitted to the sternal region of a female patient and a male patient.

**[0018]** FIG. 3 is a perspective view showing an extended wear electrode patch in accordance with one embodiment with a monitor recorder inserted.

**[0019]** FIG. 4 is a perspective view showing the extended wear electrode patch of FIG. 3 without a monitor recorder inserted.

[0020] FIG. 5 is a top view showing the flexible circuit of the extended wear electrode patch of FIG. 3.

[0021] FIG. 6 is a perspective view showing the extended wear electrode patch in accordance with a further embodiment.

[0022] FIG. 7 is an exploded view showing the component layers of the electrode patch of FIG. 3.

[0023] FIG. 8 is a bottom plan view of the extended wear electrode patch of FIG. 3 with liner partially peeled back.

#### DETAILED DESCRIPTION

[0024] Physiological monitoring can be provided through a wearable monitor that includes two components, a flexible extended wear electrode patch and a removable reusable monitor recorder. FIGS. 1 and 2 are diagrams showing, by way of examples, an extended wear electrocardiography monitor 12, including an extended wear electrode patch 15 in accordance with one embodiment, respectively fitted to the sternal region of a female patient 10 and a male patient 11. The wearable monitor 12 sits centrally (in the midline) on the patient's chest along the sternum 13 oriented top-to-bottom with the monitor recorder 14 preferably situated towards the patient's head. The electrode patch 15 is shaped to fit comfortably and conformal to the contours of the patient's chest approximately centered on the sternal midline 16 (or immediately to either side of the sternum 13). The distal end of the electrode patch 15 extends towards the Xiphoid process and, depending upon the patient's build, may straddle the region over the Xiphoid process. The proximal end of the electrode patch 15, located under the monitor recorder 14, is below the manubrium and, depending upon patient's build, may straddle the region over the manubrium.

[0025] The placement of the wearable monitor 12 in a location at the sternal midline 16 (or immediately to either side of the sternum 13) significantly improves the ability of the wearable monitor 12 to cutaneously sense cardiac electric signals, particularly the P-wave (or atrial activity) and, to a lesser extent, the QRS interval signals in the ECG waveforms that indicate ventricular activity. The sternum 13 overlies the right atrium of the heart and the placement of the wearable monitor 12 in the region of the sternal midline 13 puts the ECG electrodes of the electrode patch 15 in a location better adapted to sensing and recording P-wave signals than other placement locations, say, the upper left pectoral region. In addition, placing the lower or inferior pole (ECG electrode) of the electrode patch 15 over (or near) the Xiphoid process facilitates sensing of right ventricular activity and provides superior recordation of the QRS interval.

[0026] During use, the electrode patch 15 is first adhered to the skin along the sternal midline 16 (or immediately to either side of the sternum 13). A monitor recorder 14 is then snapped into place on the electrode patch 15 to initiate ECG monitoring. FIG. 3 is a perspective view showing an extended wear electrode patch 15 in accordance with one embodiment with a monitor recorder 14 inserted. The body of the electrode patch 15 is preferably constructed using a flexible backing 20 formed as an elongated strip 21 of wrap knit or similar stretchable material about 145 mm long and 32 mm at the widest point with a narrow longitudinal mid-section 23 evenly tapering inward from both sides. A pair of cut-outs 22 between the distal and proximal ends of the electrode patch 15 create a narrow longitudinal midsec-

tion 23 or "isthmus" and defines an elongated "hourglass"-like shape, when viewed from above, such as described in commonly-assigned U.S. Design Pat. No. D744,659, issued Dec. 1, 2015, the disclosure of which is incorporated by reference. The upper part of the "hourglass" is sized to allow an electrically non-conductive receptacle 25, sits on top of the outward-facing surface of the electrode patch 15, to be affixed to the electrode patch 15 with an ECG electrode placed underneath on the patient-facing underside, or contact, surface of the electrode patch 15; the upper part of the "hourglass" has a longer and wider profile than the lower part of the "hourglass," which is sized primarily to allow just the placement of an ECG electrode.

[0027] The electrode patch 15 incorporates features that significantly improve wearability, performance, and patient comfort throughout an extended monitoring period. During wear, the electrode patch 15 is susceptible to pushing, pulling, and torquing movements, including compressional and torsional forces when the patient bends forward, and tensile and torsional forces when the patient leans backwards. To counter these stress forces, the electrode patch 15 incorporates crimp and strain reliefs, as further described infra respectively with reference to FIGS. 4 and 5. In addition, the cut-outs 22 and longitudinal midsection 23 help minimize interference with and discomfort to breast tissue, particularly in women (and gynecomastic men). The cut-outs 22 and longitudinal midsection 23 allow better conformity of the electrode patch 15 to sternal bowing and to the narrow isthmus of flat skin that can occur along the bottom of the intermammary cleft between the breasts, especially in buxom women. The cut-outs 22 and longitudinal midsection 23 help the electrode patch 15 fit nicely between a pair of female breasts in the intermammary cleft. In one embodiment, the cut-outs 22 can be graduated to form the longitudinal midsection 23 as a narrow in-between stem or isthmus portion about 7 mm wide. In a still further embodiment, tabs 24 can respectively extend an additional 8 mm to 12 mm beyond the distal and proximal ends of the flexible backing 20 to facilitate purchase when adhering the electrode patch 15 to or removing the electrode patch 15 from the sternum 13. These tabs preferably lack adhesive on the underside, or contact, surface of the electrode patch 15. Still other shapes, cut-outs and conformities to the electrode patch 15 are possible.

[0028] The monitor recorder 14 removably and reusable snaps into an electrically non-conductive receptacle 25 during use. The monitor recorder 14 contains electronic circuitry for recording and storing the patient's electrocardiography as sensed via a pair of ECG electrodes provided on the electrode patch 15, such as described in commonly-assigned U.S. Pat. No. 9,730,593, issued Aug. 15, 2017, the disclosure of which is incorporated by reference. The circuitry includes a microcontroller, flash storage, ECG signal processing, analog-to-digital conversion (where applicable), and an external interface for coupling to the electrode patch 15 and to a download station for stored data download and device programming. The monitor recorder 14 also includes external patient-interfaceable controls, such as a push button to facilitate event marking and a resonance circuit to provide vibratory output. In a further embodiment, the circuitry, with the assistance of the appropriate types of deployed electrodes or sensors, is capable of monitoring other types of physiology, in addition to ECGs. Still other types of monitor recorder components and functionality are possible.

[0029] The non-conductive receptacle 25 is provided on the top surface of the flexible backing 20 with a retention catch 26 and tension clip 27 molded into the non-conductive receptacle 25 to conformably receive and securely hold the monitor recorder 14 in place. The edges of the bottom surface of the non-conductive receptacle 25 are preferably rounded, and the monitor recorder 14 is nestled inside the interior of the non-conductive receptacle 25 to present a rounded (gentle) surface, rather than a sharp edge at the skin-to-device interface.

[0030] The electrode patch 15 is intended to be disposable. The monitor recorder 14, however, is reusable and can be transferred to successive electrode patches 15 to ensure continuity of monitoring. The placement of the wearable monitor 12 in a location at the sternal midline 16 (or immediately to either side of the sternum 13) benefits long-term extended wear by removing the requirement that ECG electrodes be continually placed in the same spots on the skin throughout the monitoring period. Instead, the patient is free to place an electrode patch 15 anywhere within the general region of the sternum 13.

[0031] As a result, at any point during ECG monitoring, the patient's skin is able to recover from the wearing of an electrode patch 15, which increases patient comfort and satisfaction, while the monitor recorder 14 ensures ECG monitoring continuity with minimal effort. A monitor recorder 14 is merely unsnapped from a worn out electrode patch 15, the worn out electrode patch 15 is removed from the skin, a new electrode patch 15 is adhered to the skin, possibly in a new spot immediately adjacent to the earlier location, and the same monitor recorder 14 is snapped into the new electrode patch 15 to reinitiate and continue the ECG monitoring.

[0032] During use, the electrode patch 15 is first adhered to the skin in the sternal region. FIG. 4 is a perspective view showing the extended wear electrode patch 15 of FIG. 3 without a monitor recorder 14 inserted. A flexible circuit 32 is adhered to each end of the flexible backing 20. A distal circuit trace 33 from the distal end 30 of the flexible backing 20 and a proximal circuit trace (not shown) from the proximal end 31 of the flexible backing 20 electrically couple ECG electrodes (not shown) to a pair of electrical pads 34. The electrical pads 34 are provided within a moisture-resistant seal 35 formed on the bottom surface of the non-conductive receptacle 25. When the monitor recorder 14 is securely received into the non-conductive receptacle 25, that is, snapped into place, the electrical pads 34 interface to electrical contacts (not shown) protruding from the bottom surface of the monitor recorder 14, and the moisture-resistant seal 35 enables the monitor recorder 14 to be worn at all times, even during bathing or other activities that could expose the monitor recorder 14 to moisture.

[0033] In addition, a battery compartment 36 is formed on the bottom surface of the non-conductive receptacle 25, and a pair of battery leads (not shown) electrically interface the battery to another pair of the electrical pads 34. The battery contained within the battery compartment 35 can be replaceable, rechargeable or disposable.

[0034] The monitor recorder 14 draws power externally from the battery provided in the non-conductive receptacle 25, thereby uniquely obviating the need for the monitor recorder 14 to carry a dedicated power source. The battery contained within the battery compartment 35 can be replaceable, rechargeable or disposable. In a further embodiment,

the ECG sensing circuitry of the monitor recorder 14 can be supplemented with additional sensors, including an SpO<sub>2</sub> sensor, a blood pressure sensor, a temperature sensor, respiratory rate sensor, a glucose sensor, an air flow sensor, and a volumetric pressure sensor, which can be incorporated directly into the monitor recorder 14 or onto the non-conductive receptacle 25.

[0035] The placement of the flexible backing 20 on the sternal midline 16 (or immediately to either side of the sternum 13) also helps to minimize the side-to-side movement of the wearable monitor 12 in the left- and right-handed directions during wear. However, the wearable monitor 12 is still susceptible to pushing, pulling, and torqueing movements, including compressional and torsional forces when the patient bends forward, and tensile and torsional forces when the patient leans backwards. To counter the dislodgment of the flexible backing 20 due to compressional and torsional forces, a layer of non-irritating adhesive, such as hydrocolloid, is provided at least partially on the underside, or contact, surface of the flexible backing 20, but only on the distal end 30 and the proximal end 31. As a result, the underside, or contact surface of the longitudinal midsection 23 does not have an adhesive layer and remains free to move relative to the skin. Thus, the longitudinal midsection 23 forms a crimp relief that respectively facilitates compression and twisting of the flexible backing 20 in response to compressional and torsional forces. Other forms of flexible backing crimp reliefs are possible.

[0036] Unlike the flexible backing 20, the flexible circuit 32 is only able to bend and cannot stretch in a planar direction. FIG. 5 is a top view showing the flexible circuit 32 of the extended wear electrode patch 15 of FIG. 3. A distal ECG electrode 38 and proximal ECG electrode 39 are respectively coupled to the distal and proximal ends of the flexible circuit 32. The flexible circuit 32 preferably does not extend to the outside edges of the flexible backing 20, thereby avoiding gouging or discomforting the patient's skin during extended wear, such as when sleeping on the side. During wear, the ECG electrodes 38, 39 must remain in continual contact with the skin. A strain relief 40 is defined in the flexible circuit 32 at a location that is partially underneath the battery compartment 36 when the flexible circuit 32 is affixed to the flexible backing 20. The strain relief 40 is laterally extendable to counter dislodgment of the ECG electrodes 38, 39 due to tensile and torsional forces. A pair of strain relief cutouts 41 partially extend transversely from each opposite side of the flexible circuit 32 and continue longitudinally towards each other to define in 'S'-shaped pattern, when viewed from above. The strain relief respectively facilitates longitudinal extension and twisting of the flexible circuit 32 in response to tensile and torsional forces. Other forms of circuit board strain relief are possible.

[0037] The flexible circuit 32 can be provided either above or below the flexible backing 20. FIG. 6 is a perspective view showing the extended wear electrode patch 15 in accordance with a further embodiment. The flexible circuit (not shown) is provided on the underside, or contact, surface of the flexible backing 20 and is electrically interfaced to the set of electrical pads 34 on the bottom surface of the non-conductive receptacle 25 through electrical contacts (not shown) pierced through the flexible backing 20.

[0038] The electrode patch 15 is intended to be a disposable component, which enables a patient to replace the

electrode patch 15 as needed throughout the monitoring period, while maintaining continuity of physiological sensing through reuse of the same monitor recorder 14. FIG. 7 is an exploded view showing the component layers of the electrode patch 15 of FIG. 3. The flexible backing 20 is constructed of a wearable gauze, latex, or similar wrap knit or stretchable and wear-safe material 44, such as a Tricot-type linen with a pressure sensitive adhesive (PSA) on the underside, or contact, surface. The wearable material 44 is coated with a layer 43 of non-irritating adhesive, such as hydrocolloid, to facilitate long-term wear. The hydrocolloid, for instance, is typically made of mineral oil, cellulose and water and lacks any chemical solvents, so should cause little itching or irritation. Moreover, hydrocolloid is thicker and more gel-like than most forms of PSA and provides cushioning between the relatively rigid and unyielding non-conductive receptacle 25 and the patient's skin. In a further embodiment, the layer of non-irritating adhesive can be contoured, such as by forming the adhesive with a concave or convex cross-section; surfaced, such as through stripes or crosshatches of adhesive, or by forming dimples in the adhesive's surface; or applied discontinuously, such as with a formation of discrete dots of adhesive.

[0039] As described supra with reference to FIG. 5, a flexible circuit can be adhered to either the outward facing surface or the underside, or contact, surface of the flexible backing 20. For convenience, a flexible circuit 47 is shown relative to the outward facing surface of the wearable material 44 and is adhered respectively on a distal end by a distal electrode seal 45 and on a proximal end by a proximal electrode seal 45. In a further embodiment, the flexible circuit 47 can be provided on the underside, or contact, surface of the wearable material 44. Through the electrode seals, only the distal and proximal ends of the flexible circuit 47 are attached to the wearable material 44, which enables the strain relief 40 (shown in FIG. 5) to respectively longitudinally extend and twist in response to tensile and torsional forces during wear. Similarly, the layer 43 of non-irritating adhesive is provided on the underside, or contact, surface of the wearable material 44 only on the proximal and distal ends, which enables the longitudinal midsection 23 (shown in FIG. 3) to respectively bow outward and away from the sternum 13 or twist in response to compressional and torsional forces during wear.

[0040] A pair of openings 46 is defined on the distal and proximal ends of the wearable material 44 and layer 43 of non-irritating adhesive for ECG electrodes 38, 39 (shown in FIG. 5). The openings 46 serve as "gel" wells with a layer of hydrogel 41 being used to fill the bottom of each opening 46 as a conductive material that aids electrode signal pick up. The entire underside, or contact, surface of the flexible backing 20 is protected prior to use by a liner layer 40 that is peeled away, as shown in FIG. 8.

[0041] The non-conductive receptacle 25 includes a main body 54 that is molded out of polycarbonate, ABS, or an alloy of those two materials to provide a high surface energy to facilitate adhesion of an adhesive seal 53. The main body 54 is attached to a battery printed circuit board 52 by the adhesive seal 53 and, in turn, the battery printed circuit board 52 is adhered to the flexible circuit 47 with an upper flexible circuit seal 50. A pair of conductive transfer adhesive points 51 or, alternatively, metallic rivets or similar conductive and structurally unifying components, connect the circuit traces 33, 37 (shown in FIG. 5) of the flexible

circuit 47 to the battery printed circuit board 52. The main body 54 has a retention catch 26 and tension clip 27 (shown in FIG. 3) that fixably and securely receive a monitor recorder 14 (not shown), and includes a recess within which to circumferentially receive a die cut gasket 55, either rubber, urethane foam, or similar suitable material, to provide a moisture resistant seal to the set of pads 34.

[0042] While the invention has been particularly shown and described as referenced to the embodiments thereof, those skilled in the art will understand that the foregoing and other changes in form and detail may be made therein without departing from the spirit and scope.

What is claimed is:

1. An electrocardiography patch, comprising:
  - a pair of electrodes exposed on a contact surface of a flexible backing;
  - a circuit comprising a pair of circuit traces, each circuit trace electrically coupled to one of the electrodes in the pair;
  - a plurality of electrical pads positioned between the electrodes and above at least a portion of the circuit traces, wherein a pair of the electrical pads interface with the electrodes; and
  - a pair of battery leads to electrically interface a battery to another pair of the electrical pads.
2. An electrocardiography patch according to claim 1, further comprising:
  - a receptacle adhered on one end of the flexible backing opposite the contact surface.
3. An electrocardiography patch according to claim 1, further comprising:
  - an electrocardiography monitor recorder formed to fit within the receptacle.
4. An electrocardiography patch according to claim 3, further comprising:
  - at least one of an SpO2 sensor, a blood pressure sensor, a temperature sensor, respiratory rate sensor, a glucose sensor, an air flow sensor, and a volumetric pressure sensor provided to supplement the electrocardiography monitor by one of direct incorporation into the electrocardiography monitor and inclusion on the flexible backing.
5. An electrocardiography patch according to claim 3, wherein the electrocardiography monitor draws power externally from the battery.
6. An electrocardiography patch according to claim 1, further comprising:
  - one of the electrodes disposed for being adhered to a region overlying a Xiphoid process on a patient's chest; and
  - another of the electrodes being disposed for being adhered to a region near a manubrium on the patient's chest oriented centrally (in the midline) along the sternum upwards from the one electrode.
7. An electrocardiography patch according to claim 1, further comprising:
  - adhesive applied to the contact surface of the flexible backing.
8. An electrocardiography patch according to claim 1, further comprising:
  - a liner shaped to cover the contact surface of the flexible backing.

9. An electrocardiography patch according to claim 1, wherein the flexible backing extends further than outer edges of the circuit.

10. An electrocardiography patch according to claim 1, wherein the circuit is provided one of above and below the flexible backing.

11. An electrocardiography and physiological sensor monitor, comprising:

an electrode patch comprising:

a pair of electrodes exposed on a contact surface of a flexible backing;

a circuit comprising a pair of circuit traces, each circuit trace electrically coupled to one of the electrodes in the pair;

a plurality of electrical pads positioned between the electrodes and above at least a portion of the circuit traces, wherein a pair of the electrical pads interface with the electrodes; and

a pair of battery leads to electrically interface a battery to another pair of the electrical pads; and

an electrocardiography monitor comprising protruding electrical contacts that interface with the electrical pads.

12. An electrocardiography and physiological sensor monitor according to claim 11, further comprising:

a receptacle adhered on one end of the flexible backing opposite the contact surface and formed to removably receive the electrocardiography monitor.

13. An electrocardiography and physiological sensor monitor according to claim 11, further comprising at least one of:

a plurality of fasteners comprised on the non-conductive receptacle and oriented to securely receive and to hold captive the electrocardiography monitor; and

one or more tabs extending from the flexible backing of the electrode patch and configured to stretch during one or more of adhering the electrode patch to and removing the electrode patch from a patient.

14. An electrocardiography and physiological sensor monitor according to claim 11, further comprising:

at least one of an SpO<sub>2</sub> sensor, a blood pressure sensor, a temperature sensor, respiratory rate sensor, a glucose sensor, an air flow sensor, and a volumetric pressure sensor provided to supplement the electrocardiography monitor by one of direct incorporation into the electrocardiography monitor and inclusion on the electrode patch.

15. An electrocardiography and physiological sensor monitor according to claim 13, wherein the electrocardiography monitor draws power externally from the battery.

16. An electrocardiography and physiological sensor monitor according to claim 11, further comprising:

one of the electrodes disposed for being adhered to a region overlying a Xiphoid process on a patient's chest; and

another of the electrodes being disposed for being adhered to a region near a manubrium on the patient's chest oriented centrally (in the midline) along the sternum upwards from the one electrode.

17. An electrocardiography and physiological sensor monitor according to claim 11, further comprising:

adhesive applied to the contact surface of the flexible backing.

18. An electrocardiography and physiological sensor monitor according to claim 11, further comprising:

a liner shaped to cover the contact surface of the flexible backing.

19. An electrocardiography and physiological sensor monitor according to claim 11, wherein the flexible backing extends further than outer edges of the circuit.

20. An electrocardiography and physiological sensor monitor according to claim 11, wherein the circuit is provided one of above and below the flexible backing.

\* \* \* \* \*

专利名称(译)	心电图贴片		
公开(公告)号	<a href="#">US20180177423A1</a>	公开(公告)日	2018-06-28
申请号	US15/905715	申请日	2018-02-26
[标]申请(专利权)人(译)	BARDY诊断		
申请(专利权)人(译)	BARDY诊断, INC.		
当前申请(专利权)人(译)	BARDY诊断, INC.		
[标]发明人	BISHAY JON MIKALSON BARDY GUST H FELIX JASON		
发明人	BISHAY, JON MIKALSON BARDY, GUST H. FELIX, JASON		
IPC分类号	A61B5/0408 A61B5/00 A61B5/0205 A61B5/021 A61B5/08 A61B5/087 A61B5/091 A61B5/145		
CPC分类号	A61B2562/164 A61B2560/0412 A61B5/02055 A61B5/14542 A61B5/021 A61B5/087 A61B5/091 A61B5/14532 A61B5/0816 A61B5/6833 A61B5/04085 A61B5/04087 A61B5/6823 A61B5/04017 A61B5/04325 A61B5/1116 A61B5/14551 A61B5/7455 A61B2505/07 A61B2560/0271 A61B2560/045 G01N27/307 A61B5/0006 A61B5/0022 A61B5/01 A61B5/0452 A61B5/04525 A61B5/1117 A61B5/1118 A61B5/4809 A61B5/6801 A61B2562/0219		
优先权	61/882403 2013-09-25 US		
外部链接	<a href="#">Espacenet</a> <a href="#">USPTO</a>		

摘要(译)

提供心电图补丁。一对电极暴露在柔性背衬的接触表面上。电路包括一对电路迹线，并且每个电路迹线电耦合到该对电极中的一个。多个电焊盘位于电极之间并且位于电路迹线的至少一部分之上。一对电焊盘与电极接合。一对电池引线将电池电连接到另一对电焊盘。

