



(19) **United States**
 (12) **Patent Application Publication** (10) **Pub. No.: US 2020/0129727 A1**
Lazarovich (43) **Pub. Date: Apr. 30, 2020**

(54) **METHODS AND SYSTEMS OF PAVLOVIAN SLEEP INDUCTION**

A61B 5/4812 (2013.01); *A61B 5/4809* (2013.01); *A61B 5/6803* (2013.01)

(71) Applicant: **REMmedy LLC**, Stowe, VT (US)

(72) Inventor: **Mark Lazarovich**, Stowe, VT (US)

(57)

ABSTRACT

(21) Appl. No.: **16/568,627**

(22) Filed: **Sep. 12, 2019**

Related U.S. Application Data

(60) Provisional application No. 62/749,746, filed on Oct. 24, 2018.

Publication Classification

(51) **Int. Cl.**

A61M 21/02 (2006.01)

A61B 5/00 (2006.01)

A61B 5/01 (2006.01)

(52) **U.S. Cl.**

CPC *A61M 21/02* (2013.01); *A61B 5/0006* (2013.01); *A61B 5/4818* (2013.01); *A61M 2021/0016* (2013.01); *A61B 5/01* (2013.01);

A Pavlovian conditioned reflex sleep induction kit includes at least one physiological sensor, wherein the at least one physiological sensor is configured to detect at least a physiological parameter of a user and transmit a detection signal to an automatically activated scent diffuser, wherein the automatically activated scent diffuser is configured to receive an electronic activation signal and to diffuse a scent as a function of the electronic activation signal, a control circuit configured to receive the detection signal from the at least one physiological sensor, to ascertain that the user is entering a hypnagogic state, and to transmit the electronic activation signal to the automatically activated scent diffuser, thereby conditioning the user to respond to subsequent sensing of the same scent. For later use, a user-activated scent diffuser is provided, that diffuses the same scent upon activation by a user, to thereby trigger the conditioned reflex to fall asleep.

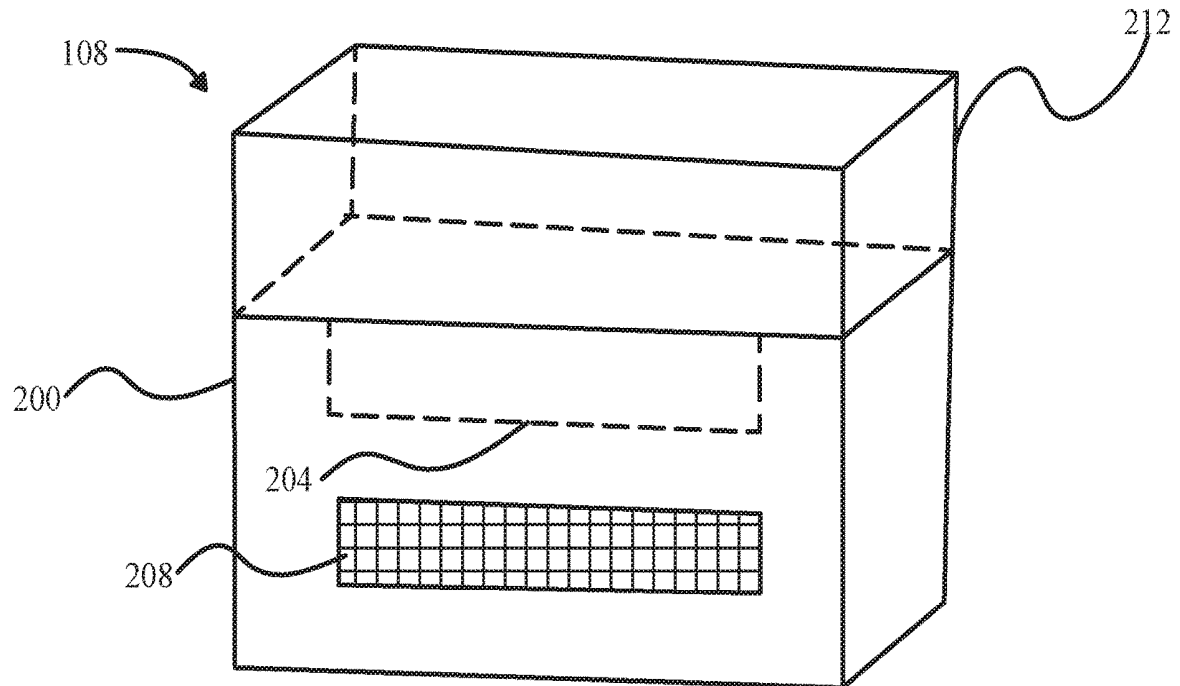

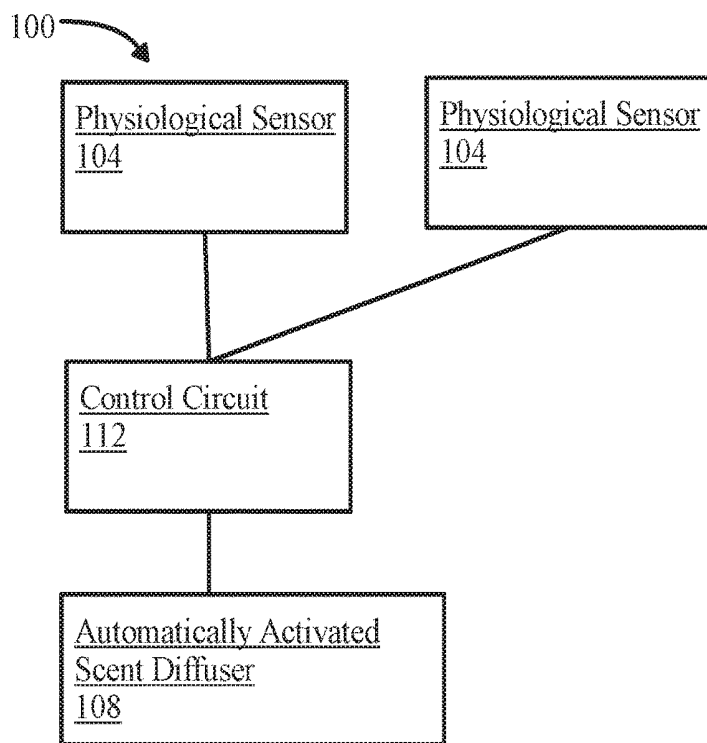

FIG. 1

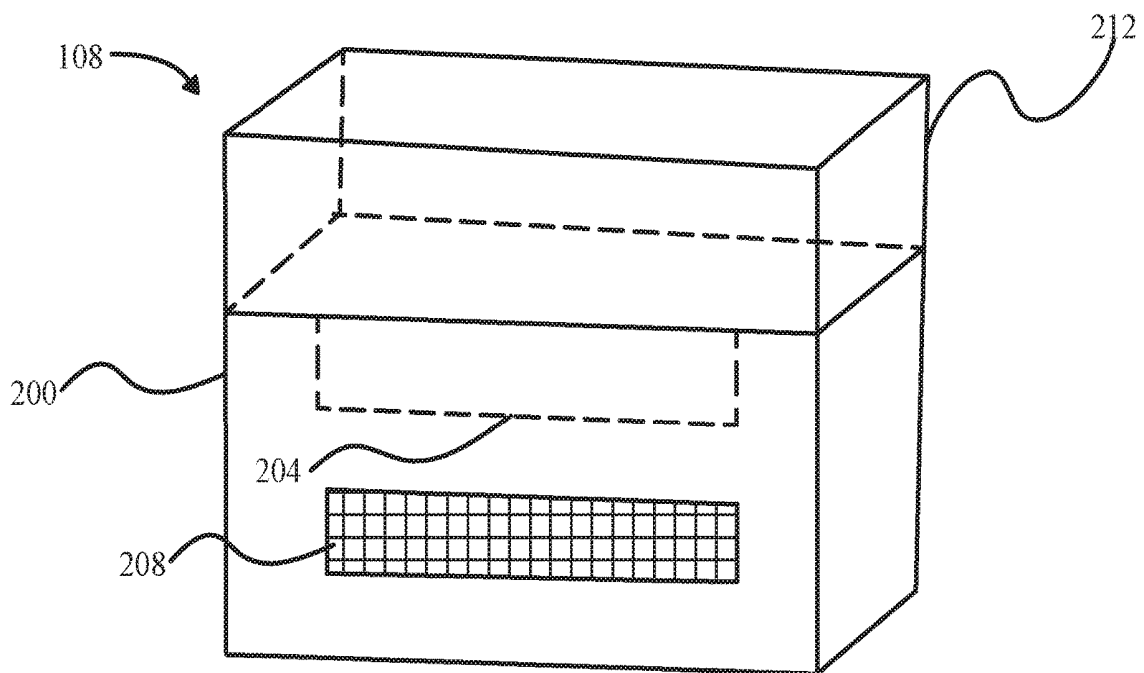

FIG. 2A

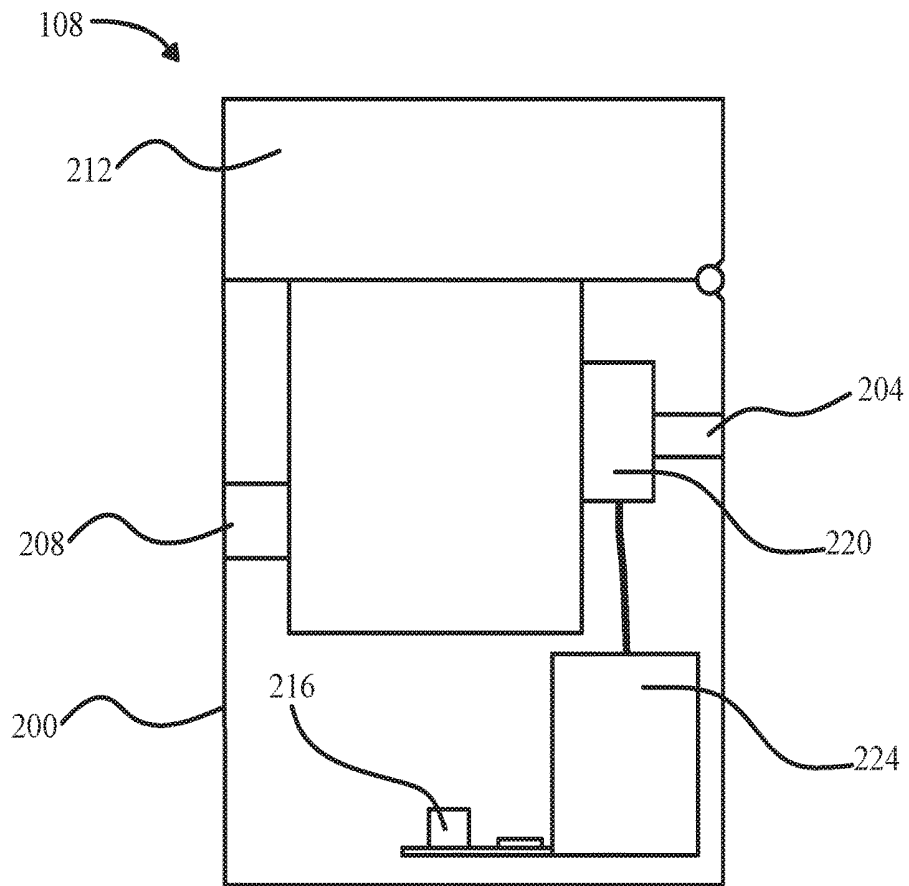

FIG. 2B

300

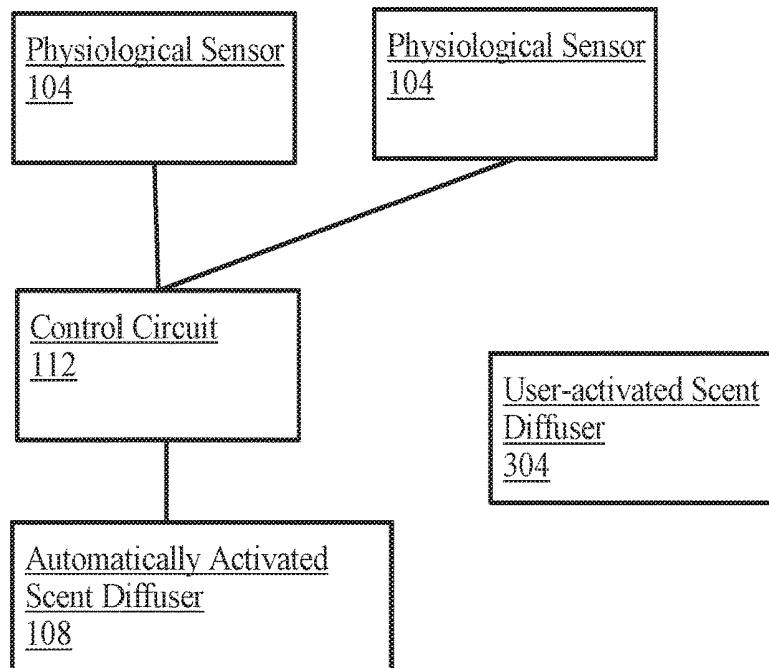

FIG. 3

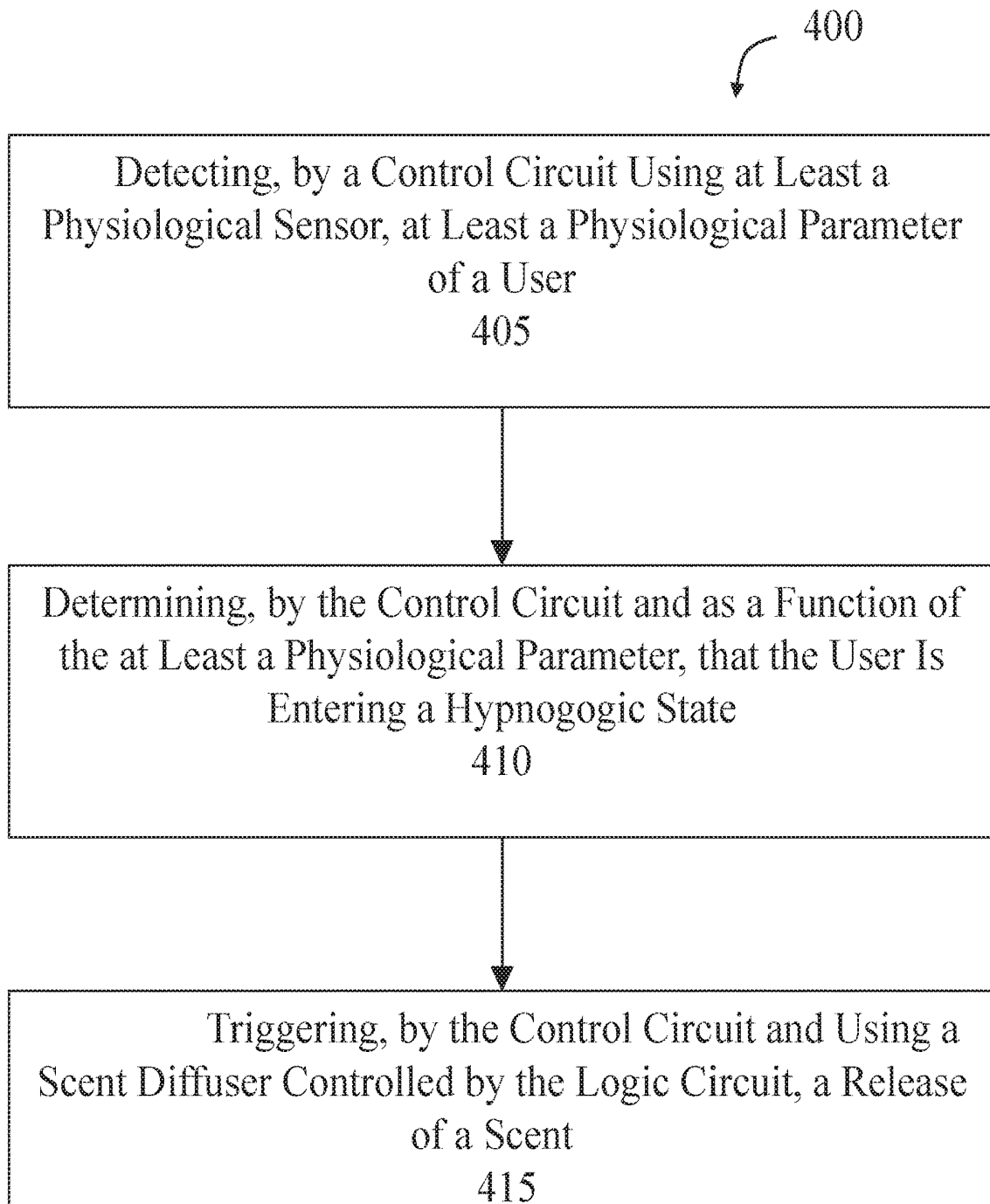

FIG. 4

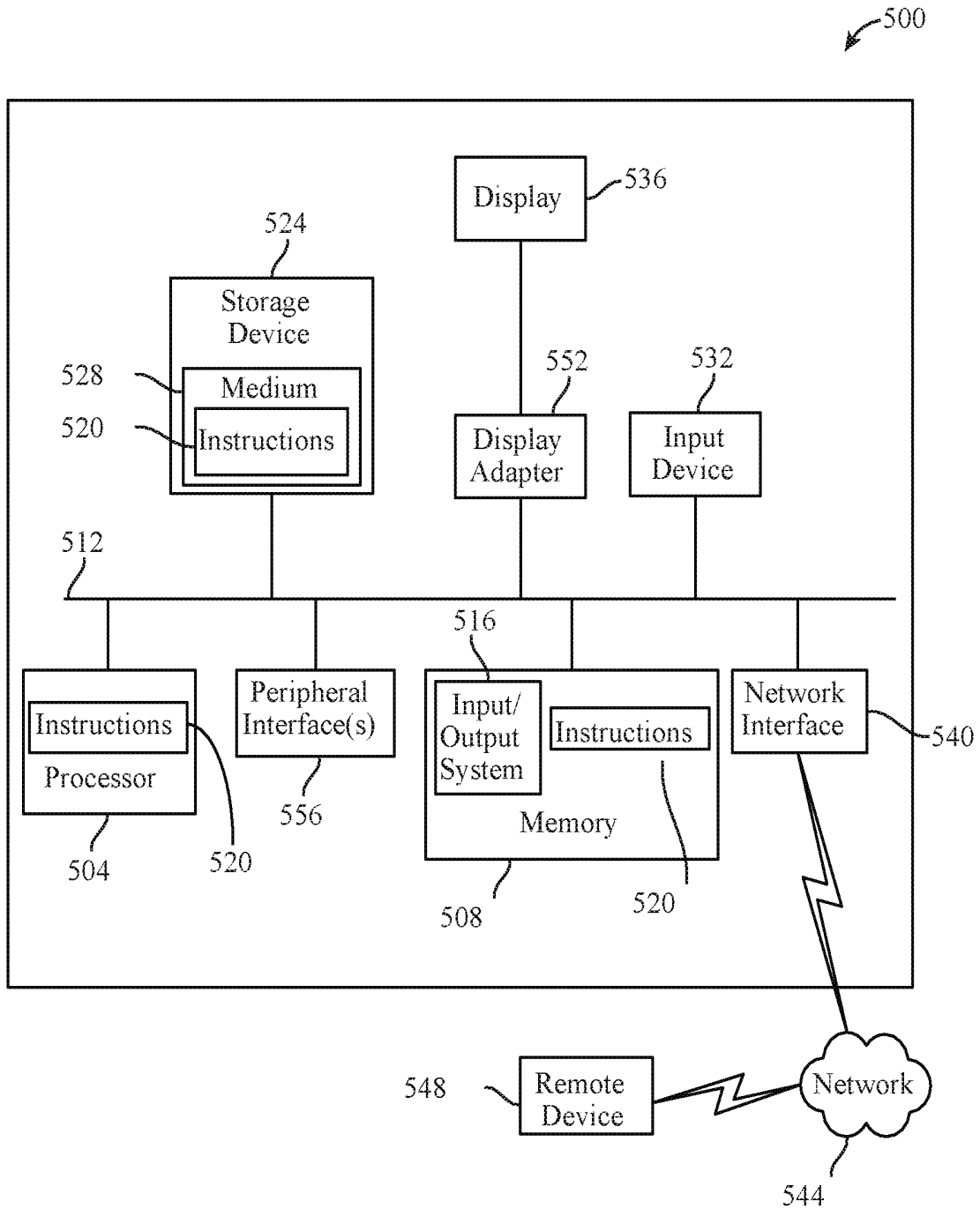

FIG. 5

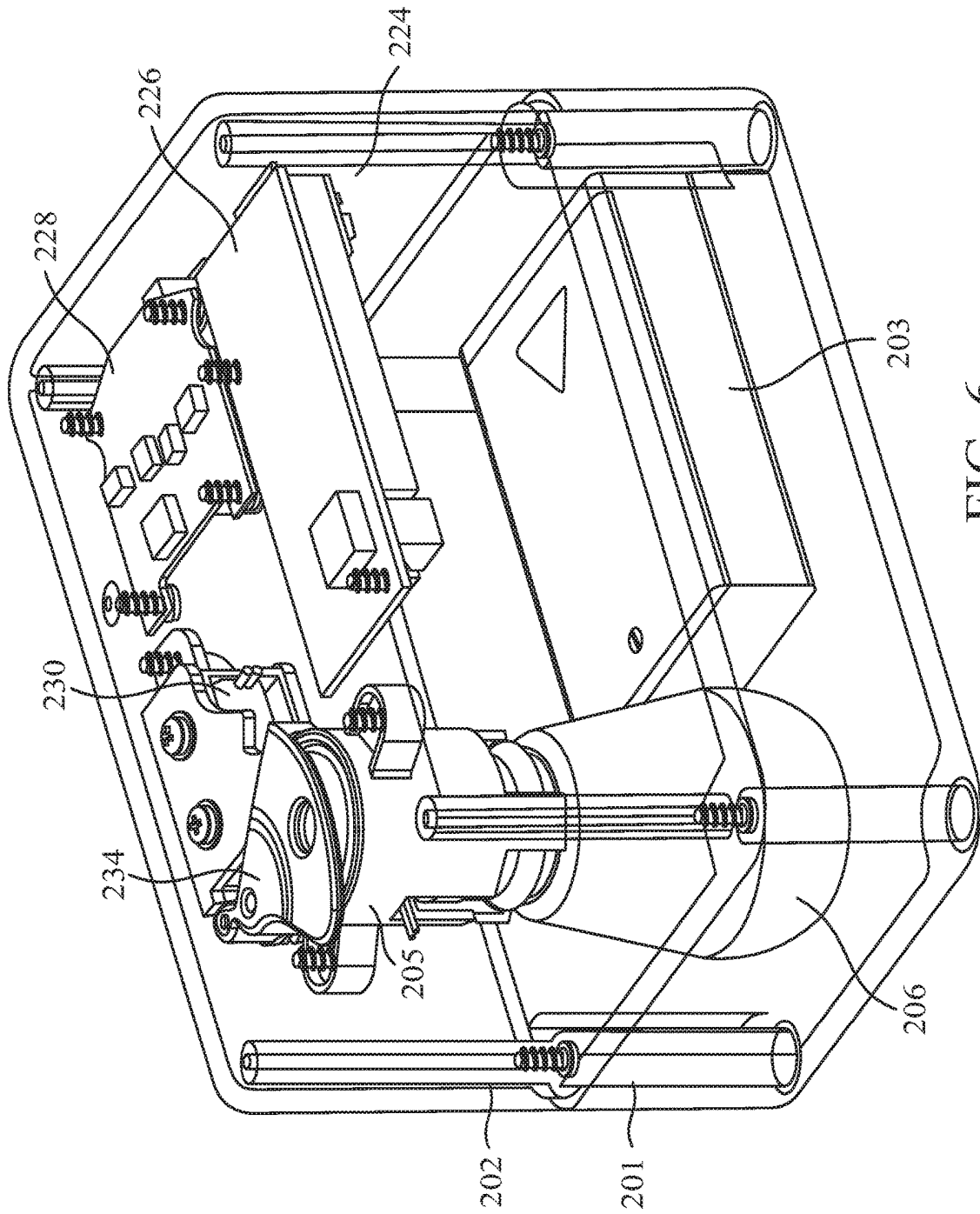

FIG. 6

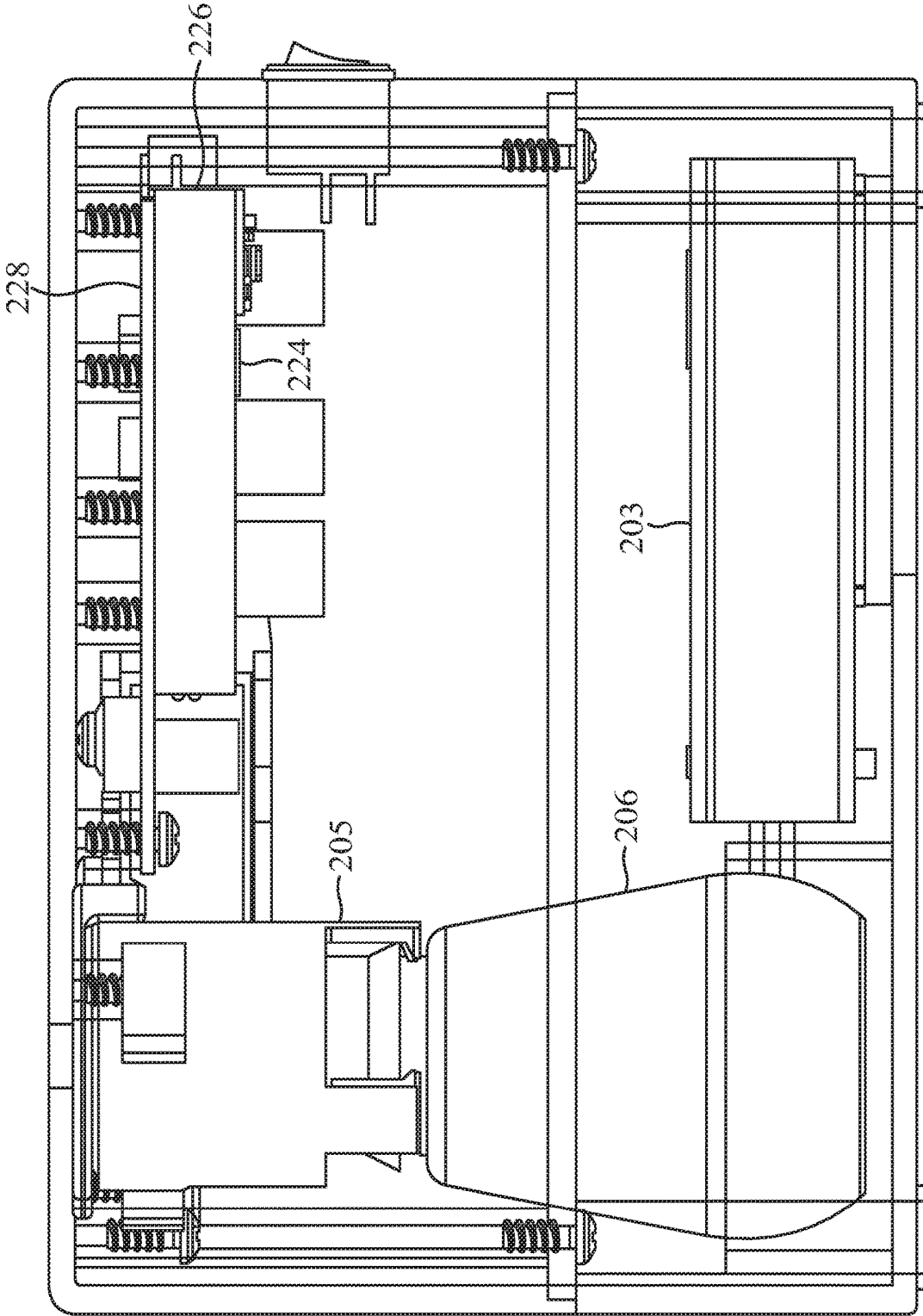

FIG. 7

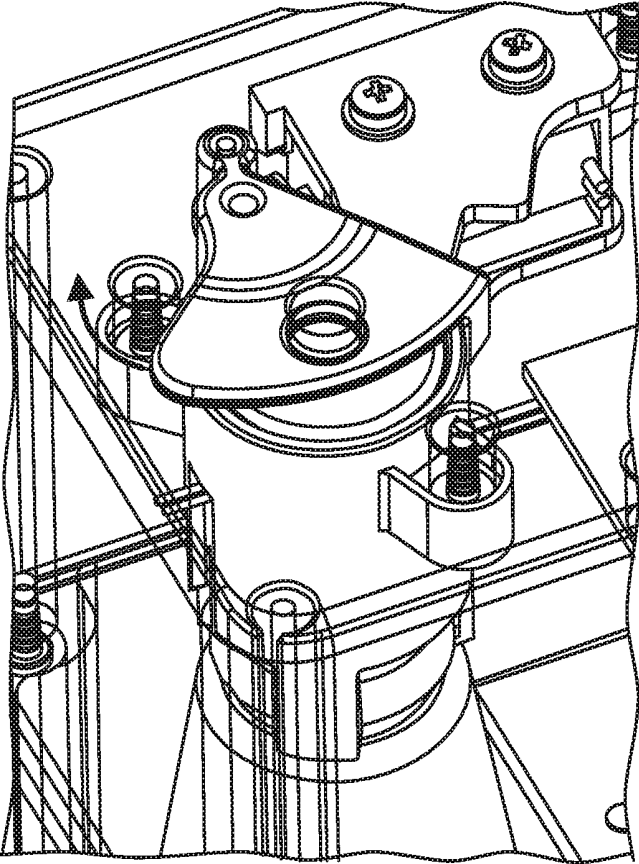

FIG. 8B

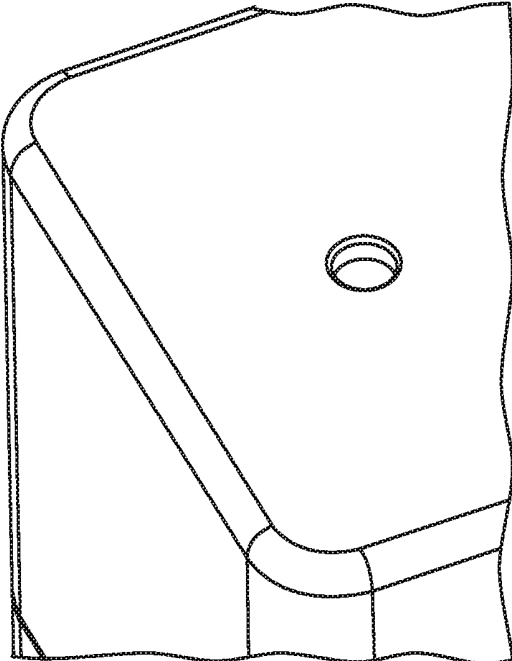

FIG. 8A

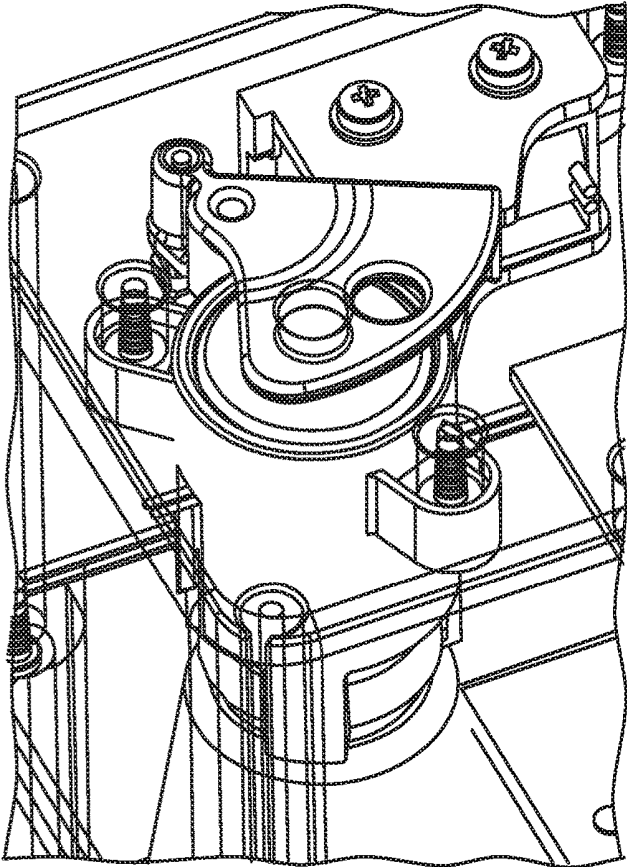

FIG. 9B

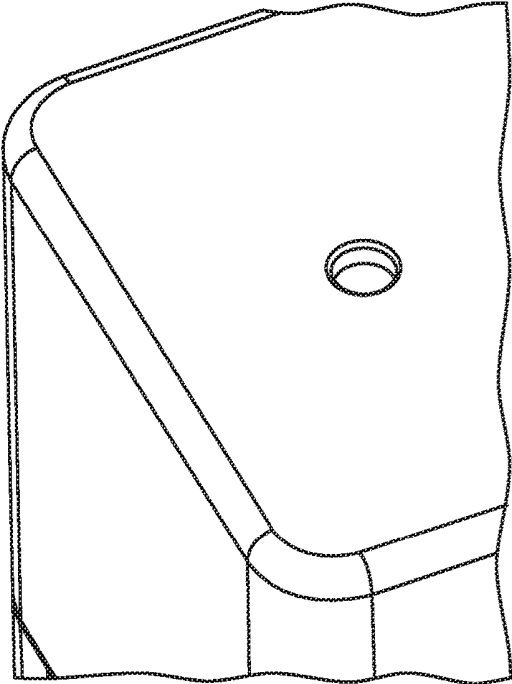

FIG. 9A

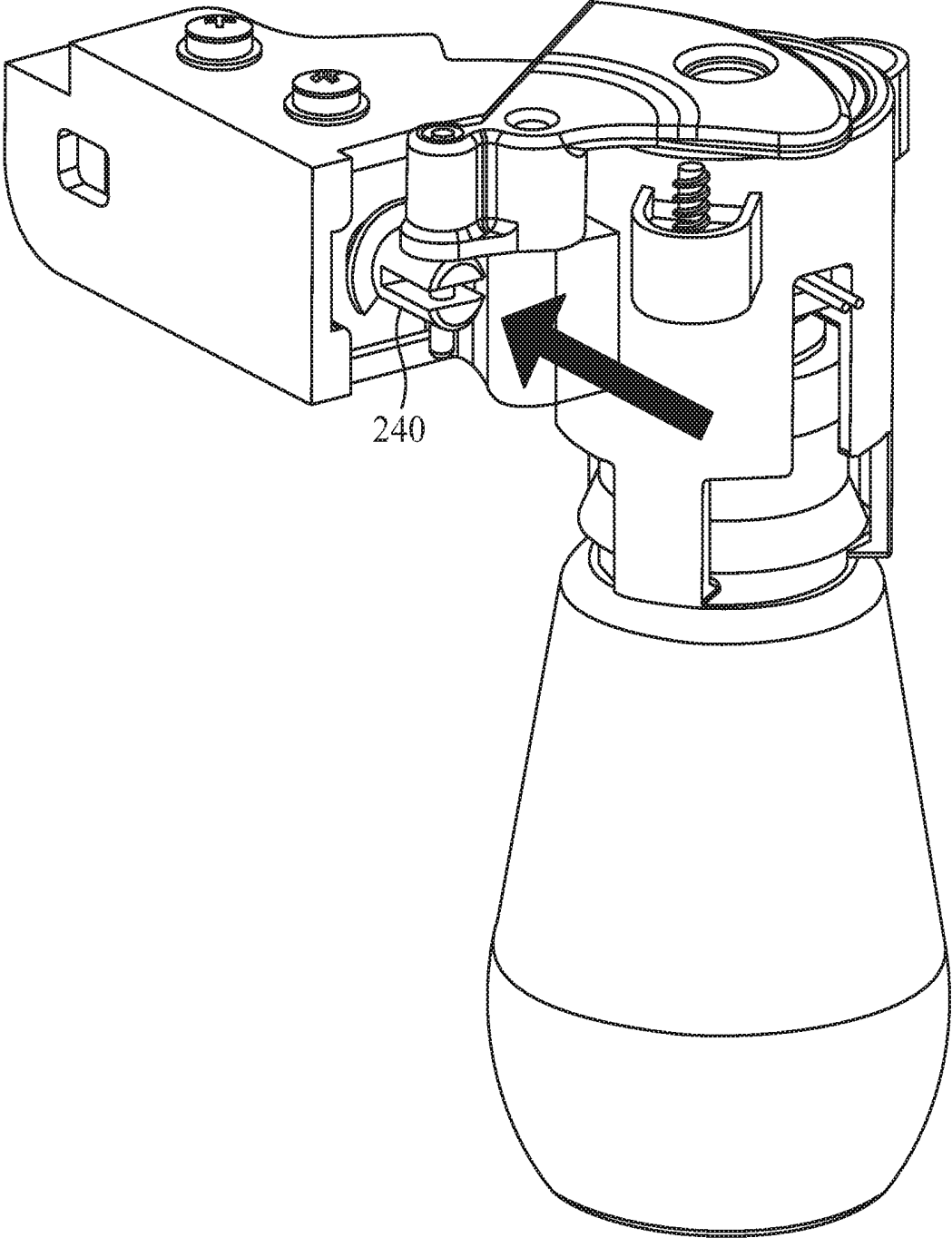

FIG. 10A

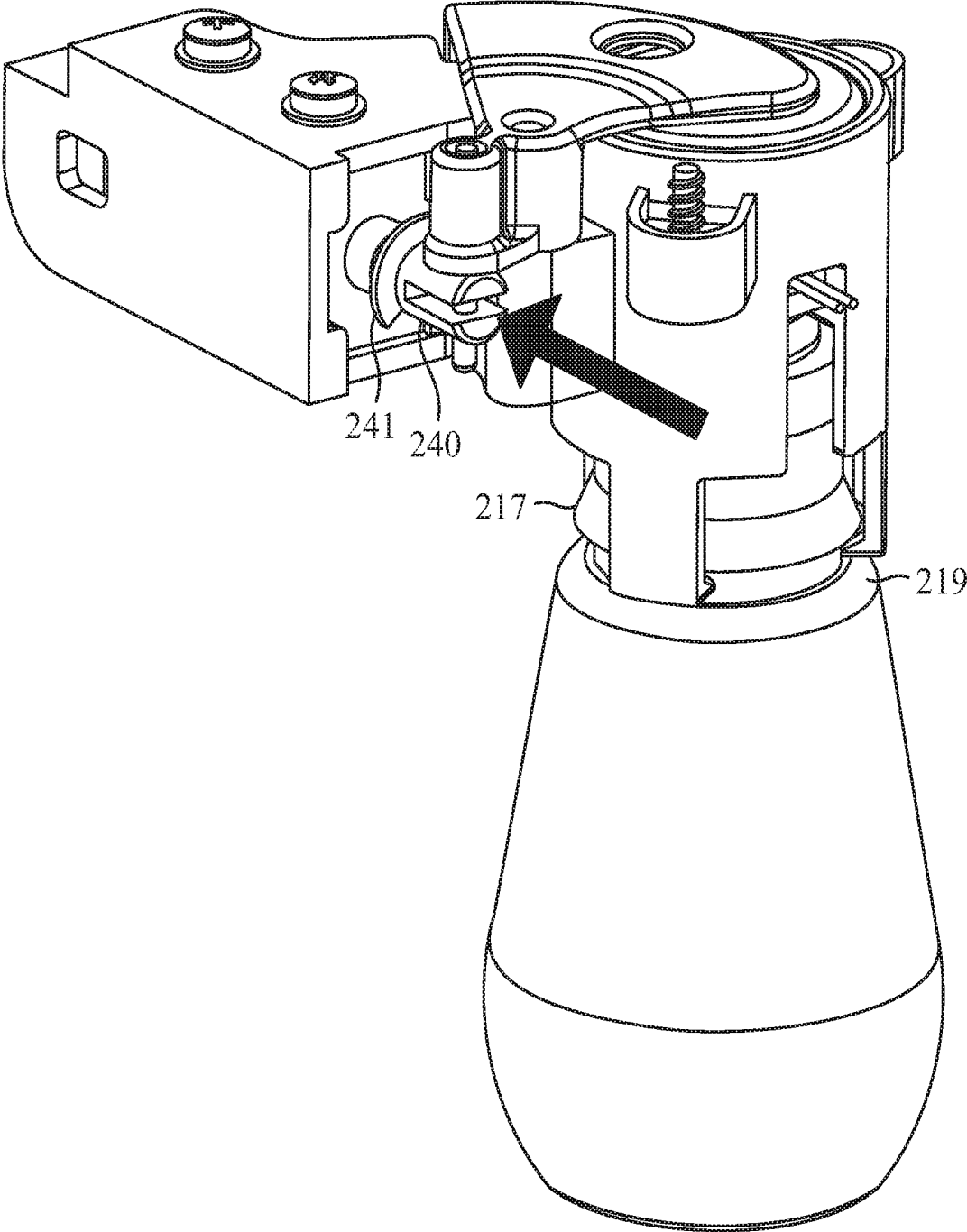

FIG. 10B

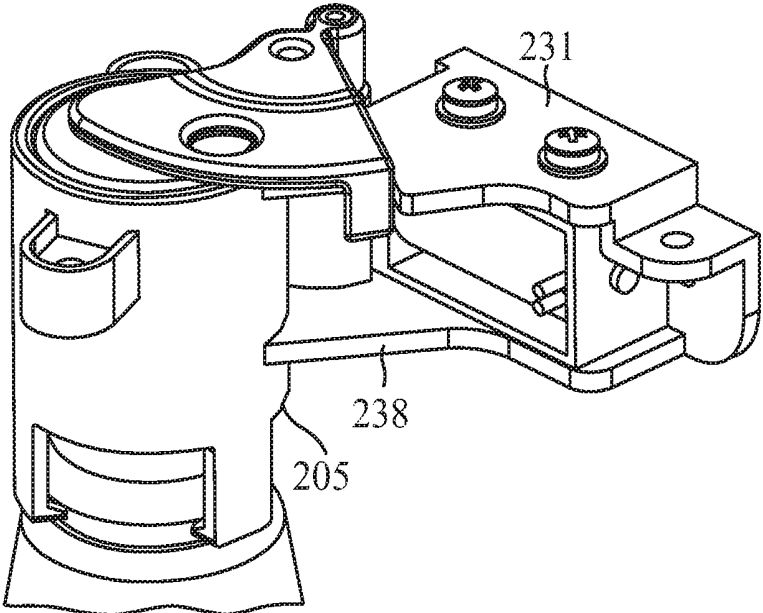

FIG. 11A

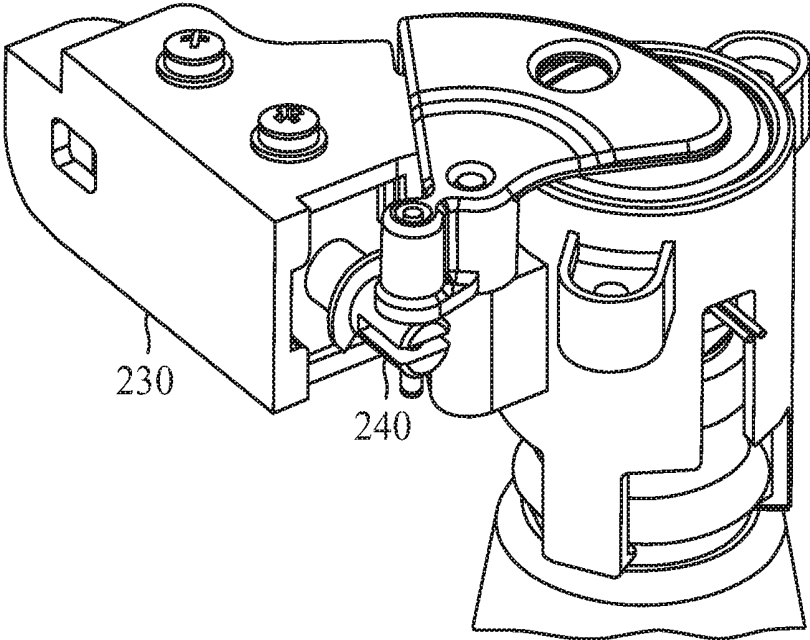

FIG. 11B

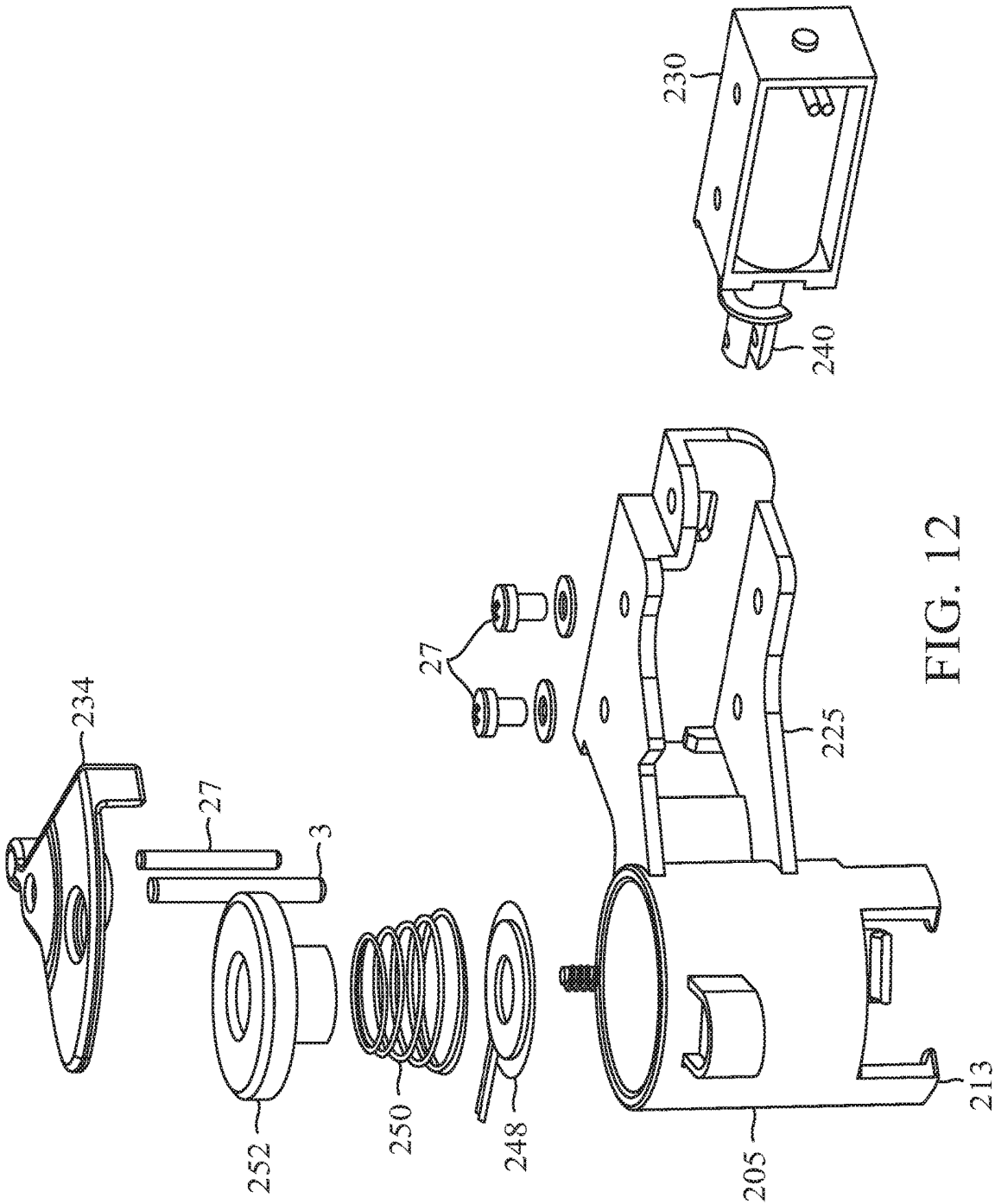

FIG. 12

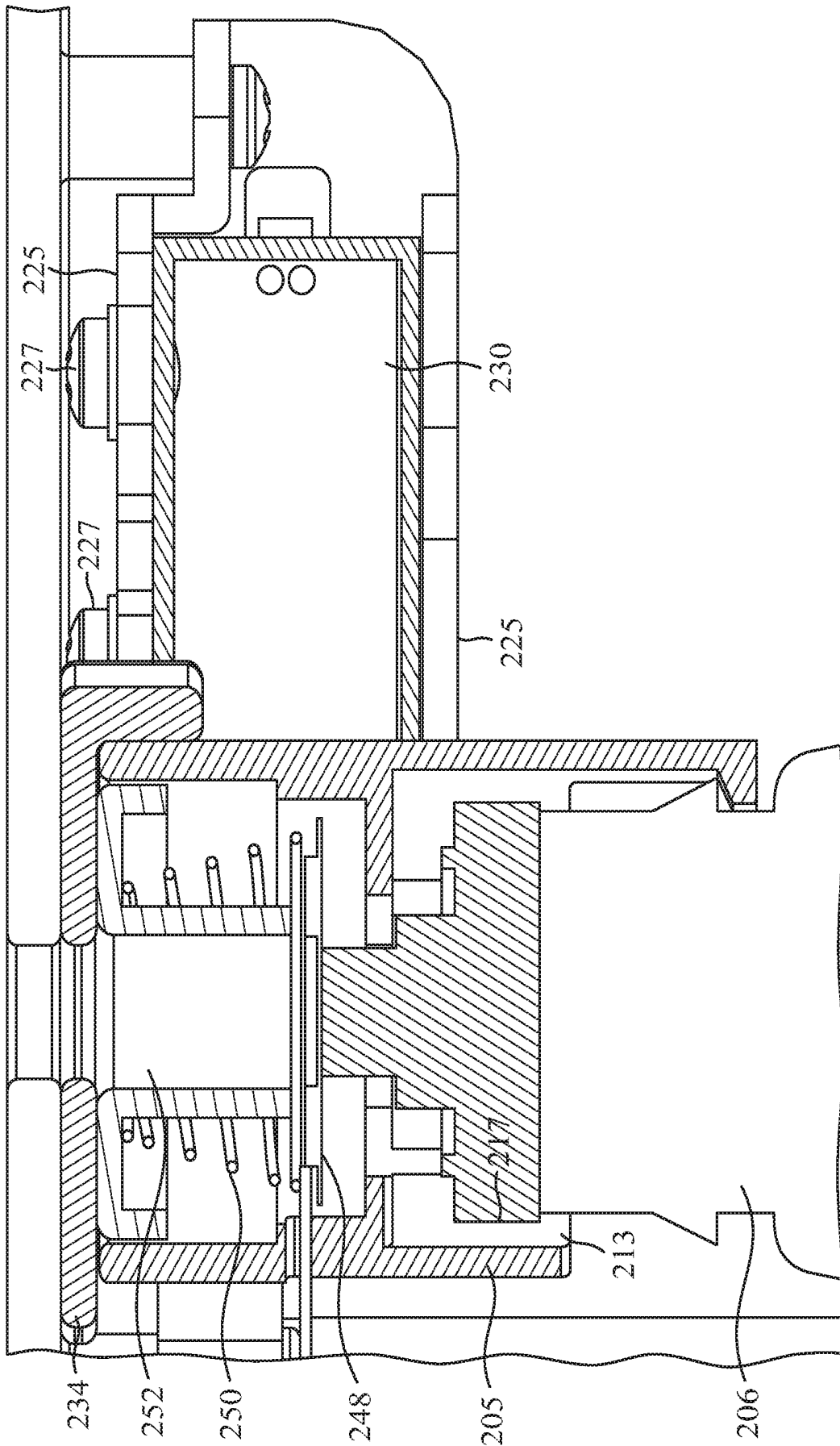

FIG. 13

METHODS AND SYSTEMS OF PAVLOVIAN SLEEP INDUCTION

CROSS-REFERENCE TO RELATED APPLICATIONS

[0001] This application claims the benefit of priority of U.S. Provisional Patent Application Ser. No. 62/749,746, filed on Oct. 30, 2018, and titled "METHODS AND SYSTEMS OF PAVLOVIAN SLEEP-INDUCTION," which is incorporated by reference herein in its entirety.

FIELD OF THE INVENTION

[0002] The present invention generally relates to the field of technologies to aid in sleep, and to counter insomnia. In particular, the present invention is directed to methods and systems for Pavlovian conditioned reflex sleep induction.

BACKGROUND

[0003] Poor sleep has a proven, significantly negative effect on health, well-being, performance, productivity, memory, work satisfaction and mood. For business travelers, consequences of poor sleep can occur at a mission-critical time, when important presentations, meetings and consultations are planned. A 2017 survey of business travelers in the United States documented that 36% of them experienced trouble sleeping in hotels. A 2019 survey documented that 80% of travelers have trouble sleeping, when away from home. Similar situational forms of insomnia can affect airline pilots and crews, shift workers, and professional athletes. Existing solutions to this problem include various devices, relying on use of stimuli intended to induce sleep, and pharmacological solutions. The former solutions rely on purported sleep-inducing properties of the stimuli in question, as evidenced by tenuous and uncertain study results regarding such sleep-inducing effects. The latter solutions vary from relatively ineffective compounds to compounds with significant and well-documented side-effects such as residual drowsiness, lethargy, hangover, tired, sluggish, and/or exhaustive feelings during wake hours, as well as dependency. The use of so-called "sleeping pills" can be associated with stigma for the user.

SUMMARY OF THE DISCLOSURE

[0004] In response to this long-felt human need for assistance in falling asleep, a system is provided which a user can employ to condition himself or herself to fall asleep, in response to a particular scent. Physiological sensors, such as EEG (electroencephalogram) or ECG (electrocardiogram) sensors, are used to detect when a user transitions into predetermined sleep stages or states. As a function of sensed physiological data, an automatic scent diffuser is actuated. The scent diffuser is later deactivated, either upon lapse of a predetermined period of activation or upon detection of a subsequent sleep stage. The user repeats this process while falling asleep on each of a plurality of consecutive nights, for example for 7 nights before commencing a journey. The user thus creates a conditioned reflex association between the scent and their usual, home falling-asleep pattern. Later, for example when first attempting to sleep during a journey, in a different time zone, or in an unfamiliar location, the user can manually activate a scent-producing device, thereby triggering the conditioned reflex of their usual, home falling-asleep process. These and other aspects and

features of non-limiting embodiments of the present invention will become apparent to those having ordinary skill in the art, upon review of the following description of specific non-limiting embodiments of the invention, in conjunction with the accompanying drawings.

[0005] These and other aspects and features of non-limiting embodiments of the present invention will become apparent to those skilled in the art upon review of the following description of specific non-limiting embodiments of the invention in conjunction with the accompanying drawings.

BRIEF DESCRIPTION OF THE DRAWINGS

[0006] For the purpose of illustrating the invention, the drawings show aspects of one or more embodiments of the invention. However, it should be understood that the present invention is not limited to the precise arrangements and instrumentalities shown in the drawings, wherein:

[0007] FIG. 1 is a block diagram illustrating an exemplary embodiment of a system for inducing a Pavlovian conditioned reflex association of a scent with initiation of sleep;

[0008] FIG. 2A is a schematic diagram illustrating a perspective view of an exemplary embodiment of an automatically activated scent diffuser;

[0009] FIG. 2B is a schematic diagram illustrating a cutaway side view of exemplary embodiment of an automatically activated scent diffuser;

[0010] FIG. 3 is a block diagram illustrating an exemplary embodiment of a Pavlovian sleep-induction kit for inducing a Pavlovian association of a scent with sleep initiation;

[0011] FIG. 4 is a flow diagram illustrating an exemplary embodiment of a method of inducing a Pavlovian association of a scent with sleep initiation;

[0012] FIG. 5 is a block diagram of a computing system that can be used to implement any one or more of the methodologies disclosed herein and any one or more portions thereof;

[0013] FIG. 6 is a perspective view of an exemplary embodiment of an automatically activated scent diffuser;

[0014] FIG. 7 is a side view, partly in cross section, of the diffuser of FIG. 6;

[0015] FIGS. 8A & 8B illustrate a bottle-open configuration of the diffuser of FIG. 6;

[0016] FIGS. 9A & 9B illustrate a bottle-closed configuration of the diffuser of FIG. 6;

[0017] FIG. 10A illustrates a piston-retraction movement of a solenoid in the diffuser of FIG. 6;

[0018] FIG. 10B illustrates a piston-extension stroke or movement of the solenoid;

[0019] FIGS. 11A & 11B illustrate, from opposing directions, mechanical connections between the solenoid of FIGS. 10A & 10B, and a bottle holder portion of the diffuser of FIG. 6;

[0020] FIG. 12 is an exploded view, showing components of the bottle holder and solenoid portions of the diffuser of FIG. 6; and

[0021] FIG. 13 is a schematic view, partly in cross section, showing an assembled state of the diffuser components of FIG. 12.

[0022] The drawings are not necessarily to scale and may be illustrated by phantom lines, diagrammatic representations and fragmentary views. In certain instances, details

that are not necessary for an understanding of the embodiments or that render other details difficult to perceive may have been omitted.

DETAILED DESCRIPTION

[0023] In an embodiment, this disclosure describes systems and methods for creating Pavlovian or conditioned reflex association between sleep entry and a scent. At least one physiological sensor may detect one or more physiological parameters of a user, which may be used by a control circuit such as a microprocessor or mobile device to identify a moment when the user is beginning to fall asleep. A control circuit may cause a scent diffuser to release a scent upon detection, which user may smell on a plurality of occasions while falling asleep, thereby creating a Pavlovian association between falling asleep and the scent. A kit, including a user-activated scent diffuser, may subsequently be used by the user to aid in falling asleep; since the user-activated scent diffuser need not communicate with sensors or other equipment to work, the user may be able to carry it anywhere, and use it in any circumstances under which the user wishes to sleep.

[0024] Referring now to FIG. 1, an exemplary embodiment of a system 100 is illustrated, for inducing a Pavlovian or conditioned reflex association of a scent with sleep initiation. System 100 includes at least a physiological sensor 104. At least a physiological sensor 104 may be any device or component that measures a physiological parameter of a user and generates an electrical signal as a function of the measurement. At least a physiological parameter may include any information that may be sensed from user's body, including without limitation any electrical, chemical, optical, auditory, olfactory, kinetic, or other information; at least a physiological parameter may include, without limitation, galvanic skin response or skin conductance response, pulse rate, breathing rate, blood flow, heartbeat signatures, electrolyte type and/or concentration, blood metabolite levels or ratios, blood pH level, position and/or balance, body strain, neurological functioning, brain activity, brain waves, blood pressure, cranial pressure, hydration level, auscultatory information, skin and/or core body temperature, facial emotions, eye muscle movement, body movement, blood volume, inhaled and/or exhaled breath volume, exhaled breath physical and/or chemical composition, reflex response sleepiness, response to external stimuli, swallowing volume, swallowing rate, head position or tilt, internal body sounds, functional near-infrared spectroscopy signals, snoring, and/or other physiological information. Various non-limiting examples of such parameters are described in further detail in this disclosure with regard to exemplary categories and/or embodiments of at least a physiological sensor 104.

[0025] Still referring to FIG. 1, at least a physiological sensor 104 may include, without limitation, at least an electrophysiologic sensor, defined herein as a sensor that detects at least an electrical, magnetic, or electromagnetic parameter, state, or reading regarding body of user. At least an electrophysiologic sensor may include an electrodynamic sensor device configured to sense an electrical activity of the heart of a subject. For example, the electrodynamic sensor may be configured to sense a heart rate or heart rate variability pattern using electrical activity of the heart, for instance using electrocardiography (ECG or EKG), or conductivity. Electrocardiography may include a process of

recording electrical activity of a heart over a period of time using electrodes placed on the skin; electrodes may detect tiny electrical changes on the skin that arise from a heart muscle's electrophysiologic pattern of depolarizing during each heartbeat. An ECG may be used to measure rate and rhythm of heartbeats or other patterns relating to heartbeats, including without limitation heart rate variability (HRV) patterns. Electrodes may be placed in contact with the user's skin using any suitable means, including adhesion or incorporation in a wearable device such as a band of elastic material around user's torso, that places electrodes in contact with user's skin. In some embodiments, direct contact may not be necessary, and electrical functioning may be monitored capacitively, inductively, electromagnetically, optically, or a combination of these approaches. Persons having ordinary skill in the art, upon reviewing the entirety of this disclosure, will be aware of various ways in which EKG data may be collected, consistent with the instant disclosure.

[0026] With continued reference to FIG. 1, at least an electrophysiologic sensor may include a sensor that monitors neurological functioning. As a non-limiting example, electrophysiologic sensor may include one or more sensors that perform an electroencephalogram (EEG); EEG may involve detection of patterns, such as brain waves, otherwise known as neural oscillations. EEG may be performed by detection of electrical patterns in neural activity using electrodes contacting a user's cranium, such as electrodes placed along a forehead of user. Electrodes may be adhered to user or incorporated in a wearable device, such as without limitation an earpiece or item of headgear placing electrodes at cranial locations such as a forehead or temple. In some embodiments, direct contact may not be necessary, and neurological functioning can be monitored capacitively, inductively, electromagnetically, or a combination of these approaches. In some embodiments, brain waves may couple with low frequency acoustical sensors integrated into a head-mounted module, or the like. Persons having ordinary skill in the art, upon reviewing the entirety of this disclosure, will be aware of various ways in which EEG data may be collected, consistently with the instant disclosure.

[0027] Continuing to view FIG. 1, at least an electrophysiologic sensor may include a sensor configured to perform an electrooculogram (EOG); EOG may be defined as an electrophysiologic measurement of eye motion. EOG may be collected using electrodes mounted at or near user's eyes, for instance through use of a mask or other wearable device that contacts the user's eyelids or rests nearby. EOG may be detected through contactless means such as capacitive, inductive, or electromagnetic detection. Alternatively or additionally, at least an electrophysiologic sensor may include electrodes or other sensors for monitoring an electromyogram (EMG) signal measuring electrical activity of muscles or muscular tissue of a user. At least an electrophysiologic sensor may include an electrodermal activity (EDA) sensor, also known as skin conductance, galvanic skin response (GSR) sensor, electrodermal response (EDR) sensor, or the like, which may measure continuous variation in electrical characteristics of skin.

[0028] Still viewing FIG. 1, at least a physiological sensor 104 may include one or more sensors configured to detect arterial or vascular data. For instance and without limitation, at least a physiological sensor 104 may include a photoplethysmography (PPG) sensor, which may sense the body's rate of blood flow using a light-based technology whereby a

light source is emitted through or at tissue containing blood vessels, and light reflected by or transmitted through the tissue is measured. At least a physiological sensor **104** may include an impedance plethysmograph for measuring changes in volume within an organ or body (usually resulting from fluctuations in the amount of blood or air it contains). For example, an impedance plethysmograph to monitor blood pressure in real-time. At least a physiological sensor **104** may include a sensor to detect pulse oximetry, where pulse oximetry is a standard noninvasive technique of estimating blood gas levels. Pulse oximeters typically employ two or more optical wavelengths to estimate the ratio of oxygenated to deoxygenated blood. Similarly, various types of hemoglobin, such as methemoglobin and carboxyhemoglobin may be differentiated by measuring and comparing the optical absorption at key red and near-infrared wavelengths. Additional wavelengths may be incorporated and/or replace conventional wavelengths. For example, by adding additional visible and infrared wavelengths, myoglobin, methemoglobin, carboxyhemoglobin, bilirubin, SpCO.sub.2, and blood urea nitrogen (BUN) may be estimated and/or monitored in real-time in addition to the conventional pulse oximetry.

[0029] With continued reference to FIG. 1, at least a physiological sensor **104** may monitor blood pressure, using, as a non-limiting example, a digital blood pressure monitor; digital blood pressure monitor may include actuators and sonic and pressure transducers placed on the skin, and may measure systolic and/or diastolic pressure, for instance by monitoring a pressure at which a “Korotkoff sound” is first heard (systolic), then disappears (diastolic). This technique may also be used to monitor intra-cranial pressure and other internal pressures. Blood pressure may also be measured by comparing the time between pulses at different regions of the body. At least a physiological sensor **104** may alternatively or additionally include pyroelectric sensor for monitoring heart rate, heart rate variability (HRV) patterns, and the like.

[0030] Still referring to FIG. 1, at least a physiological sensor **104** may include a body temperature sensor, which may be any sensor that acquires a temperature of user's body or a portion thereof. Temperature sensor may include, without limitation one or more infrared sensors, which may be composed of thermoelectric/pyroelectric materials or semiconductor devices, such as photodiodes or photoconductors, thermistors, thermocouples, or any other elements or components used in digital and/or electric thermometers or other temperature sensors. Temperature sensor may detect a skin temperature at one or more locations on user's body. Temperature sensor may contact user, or may detect user temperature remotely, for instance by capturing infrared radiation.

[0031] Continuing to refer to FIG. 1, at least a physiological sensor **104** may include at least a motion sensor. At least a motion sensor may include at least a gyroscope, which may detect orientation changes of the at least a gyroscope; multiple gyroscopes may detect orientation changes with respect to multiple axes, such as three gyroscopes to detect orientation changes with respect to three axes of rotation, or the like. At least a motion sensor may include at least an accelerometer, such as one or more microelectromechanical systems (MEMS) devices. An accelerometer may measure acceleration or position in two or more axes; alternatively or additionally, at least an accelerometer may include a plural-

ity of accelerometers to detect acceleration with respect to a plurality of axes, such as without limitation three accelerometers that detect motion with regard to three dimensional axes. At least a motion sensor may include an inertial measurement unit (IMU), which may include multiple types of motion sensors in a single chip or system. At least a motion sensor may be mounted to one or more parts of user's body to detect motion thereof. Changes in patterns in user motion may indicate a transition by user from one state of wakefulness or sleep to another state; for instance, a step towards a deeper sleep state or in a direction transitioning from waking to sleep, as described in further detail below, and may be accompanied by a decrease in or cessation of movement by user, and/or by an increased regularity of chest movements indicating regular breathing in a pattern indicative of incipient slumber.

[0032] As a further non-limiting example, and still referring to FIG. 1, at least a physiological sensor **104** may include at least a camera. At least a camera may be any electronic device capable of capturing light, whether in visible or non-visible spectra, and transmitting an electrical signal based on the detection. At least a camera may, as a non-limiting example, capture an eye area of a user, to ascertain, based on the analysis of the captured images, whether or not an eye movement occurs; when the eye stops, for instance, the user's sleep state may be determined to be rapid-eye movement (REM) or non-REM sleep state. Similarly, the camera may track user's blink rate, including without limitation user's involuntary blink rate, which may be indicative of increased drowsiness. Camera may detect body movement of user, which may be used similarly to body movements detected by at least a motion sensor; camera may, for instance, capture a sequence of images of user's body and compare images of the sequence of images to determine whether user has moved user's body and, if so, how frequently or to what extent.

[0033] Continuing to refer to FIG. 1, at least a physiological sensor **104** may include at least an acoustic sensor, such as a microphone or the like. At least an acoustic sensor may detect and/or monitor breathing characteristics of user, for instance via auscultatory signal extraction. In an embodiment, an acoustic sensor may be used to sense sounds associated with breathing. Signal processing algorithms may then be used to extract breathing sounds from other sounds and noise, for instance using digital signal filtering or noise elimination processes. This information may be used, as a non-limiting example, to measure and/or track intensity, volume, and speed of breathing, which may in turn be used to determine a user's state of wakefulness, state of sleep, or near-sleep condition. Alternatively or additionally, at least a physiological sensor **104** may monitor breathing using employ pressure transducers. For instance, and without limitation, changes in pressure inside or near the ear associated with breathing may be measured directly and, through signal processing, translated into a breathing monitor. Similarly, optical reflection sensors may be used to monitor pressure by monitoring physical changes in the skin or tissues in response to breathing. For monitoring the physical changes of the tympanic membrane in response to breathing, and hence ascertaining breathing rate, an optical signal extraction approach may be employed. As a further non-limiting example, microphones positioned correctly near a

sleep surface can sometimes pickup and detect a heartbeat and respiration. Microphones can also hear snoring, coughing, or the like.

[0034] Still referring to FIG. 1, at least a physiological sensor **104** is configured to detect at least a physiological parameter of user and transmit a detection signal. Detection signal may be transmitted via wired connection to one or more other elements of system **100** as described below; for instance, and without limitation, at least a physiological sensor **104** may be incorporated in a single electronic device, or mounted on a single chip, with one or other additional components of system **100**. Alternatively or additionally, detection signal may be transmitted to one or more components of system **100** wirelessly. For instance, and without limitation, at least a physiological sensor **104** may include one or more wireless transceivers, which may communicate according to protocols such as BLUETOOTH®, ANT+, Wi-Fi, or ZigBee and may be configured to transmit information wirelessly one or more other components of system **100**.

[0035] Continuing to refer to FIG. 1, system **100** includes an automatically activated scent diffuser **108**. Automatically activated scent diffuser **108** is configured to receive an electronic activation signal and diffuse a scent as a function of the electronic activation signal; the automatically activated scent diffuser **108** may be any device that can selectively release a scent into the air, so that user can smell the scent. Scent diffuser may include a scent source, which may include a material that releases scent molecules into the air. Scent molecules may include any molecules that human olfactory receptors detect as having an aroma. Scent molecules may pass through air to a user's nose by diffusion. Scent molecules may have aromas recognizable to users; aromas may include aromas generally considered pleasant, such as the aromas of fruits, flowers, herbs, pine needles, or the like. Scent source may include a material containing one or more volatile materials that either have the desired aroma or carry molecules having the desired aroma in solution. Scent source may include one or more scent wafers, which may release scent upon exposure to air, for instance by evaporation of volatile materials contained within scent wafer. Scent source may include one or more scent liquids, such as perfumes, essential oils, or the like; scent liquids may be volatile, or contain volatile materials, causing diffusion through evaporation. Scent-diffusing material may include a gas. Scent source may be in any other suitable form, including a film, foam, or gel. Scent source may include a material that releases scent molecules under specific circumstances; for instance, scent source may include a wafer, film, liquid, or other material that releases scent only on exposure to heat, electric current, or the like. As a non-limiting example, scent source may contain a mixture or solution of volatile or scent-diffusing material with a substance that seals the scent-diffusing material at a first temperature, such as room temperature, but changes to release scent-diffusing material at a second temperature, which may be a higher temperature; substance may be waxy, may have a structure that encapsulates scent-diffusing material in small envelopes or capsules of material that will open or rupture upon exposure to heat, or may combine with scent-diffusing material via chemical bonds that release upon heat exposure. Alternatively or additionally, substance may be a material that encapsulates or maintains a chemical bond to scent-diffusing material until exposed to an electric current

or field. In an embodiment, removal of a release stimulation may result in a cessation of diffusion of scent; for instance, where substance encapsulates scent-diffusing material until exposure to ultrasonic vibration, heat or electric currents and/or fields, cessation of heat, ultrasonic vibration, or electric currents and/or fields may cause substance to re-encapsulate scent-diffusing material. Similarly, chemical bonds that are separated by heat, ultrasonic vibration, and/or electric current and/or fields may reform upon cooling or cessation of the electric stimulus. Heat used to release scent-diffusing material may be applied using an electrical heating element, which may be controlled by a control circuit **112**, microprocessor, microcontroller, or the like; electric current and/or field may be similarly provided electrically. Ultrasonic vibration may be applied using any electrically triggered sonic vibration generating component, such as, without limitation, piezoelectric vibrating components. Automatically activated scent diffuser may be located near user's head and/or nose.

[0036] Still viewing FIG. 1, scent-diffusing material may be contained in an enclosed container and selectively released. For instance, where scent-diffusing material includes a liquid or gel, scent-diffusing material may be contained in a cartridge, compartment, or bottle-like component that may be sealed until release is desired. Where scent-diffusing material includes a film, foam, or solid object such as a wafer, scent-diffusing material may be stored in a cartridge, wrapper, or compartment that may be selectively opened when scent diffusion is desired. A scent-diffusing gas may similarly be contained in a cartridge or compartment; scent-diffusing gas may be contained under pressure. Selective opening of enclosed container may include piercing a wrapper, opening a selectively closable aperture, or the like. Alternatively or additionally, liquid, gas, or gel may be released from one or more nozzles, such as spray nozzles; nozzles may be mechanically or electrically actuated in any suitable way, including forcing of scent-diffusing material through nozzles using a pump, impeller, or other pressure source, including pressurized cartridges. Nozzles may be actuated by opening a valve. An aperture of enclosed container may be opened by electrically controlled mechanical movement of a door or lid, for instance using an electric motor or linear actuator, a servo, or the like.

[0037] Continuing to view FIG. 1, automatically activated scent-diffuser may include one or more dispersal mechanisms. Where nozzles are used, dispersal may be aided in part by pressurized ejection from nozzles. Dispersal mechanisms may similarly include an ultrasonic nebulizer, air-blowing component such as a fan, impeller, pump, or micropump, which causes airflow past scent-diffusing material, carrying it and resulting aromas to user's nose or speeding up diffusion to accomplish the same. Automatically activated scent diffuser **108** may be incorporated in a home heating, ventilation, and/or air-conditioning system, permitting air circulation of such a system to aid in dispersal or diffusion of scent molecules. In an embodiment, where automatically activated scent diffuser **108** includes a heater, the heater may cause air currents through convection, which may have a similar effect to air blowing component. One or more dispersal mechanisms may include additional or alternative components, such as a wick, which may draw scent-diffusing material using capillary action from a container or enclosure to exposure to open air, where evaporation may disperse scent-diffusing material or enclosure to exposure to

open air, where evaporation may disperse scent-diffusing material. A dispersal mechanism may include an ultrasonic nebulizer atomizing the scent-diffusing material and dispersing it to open air. Automatically activated scent diffuser may be configured to stop diffusing scent upon reception of a deactivation signal.

[0038] Referring now to FIG. 2A, an exemplary embodiment of an automatically activated scent diffuser 108 is illustrated. Automatically activated scent diffuser 108 may have a housing 200, which may be in any suitable form, including without limitation a box form. Housing 200 may include an air intake 204, which may include or communicate with an aperture or selectively closable aperture of a compartment containing scent-diffusing material as described above. Housing 200 may include a diffusing vent 208, which may include a grid or other covering; diffusing vent 208 may include or communicate with an aperture or selectively closable aperture of a compartment containing scent-diffusing material as described above. Housing 200 may include a manually activated opening 212, such as a hinged and/or latched lid, which may be used to open housing 200 and/or compartment containing scent-diffusing material; manually activated opening 212 may cause scent release when opened, be used to insert additional scent-diffusing material in automatically activated scent diffuser 108, or the like. Referring now to FIG. 2B, housing 200 may contain one or more components of automatically activated scent diffuser 108 as described above, including a transceiver 216, such as a transceiver as described above, an electronic fan controller, an electric fan 220 with a motor, a battery 224, and the like. Housing 200 may include a receptacle for a scent wafer. Housing 200 may include a power switch.

[0039] Still referring to FIG. 2B, in operation, automatically activated scent diffuser 108 may prevent scent diffusion until receipt of an activation signal; for instance, where present, diffusing vent 208 and air intake 204 may be sealed initially, preventing scent dispersal. Upon an electronic activation signal, which may be received via any suitable means, including a signal to transceiver, automatically activated scent diffuser 108 may diffuse scent using any mechanisms, components, or combination thereof; for instance, and without limitation, where automatically activated scent diffuser 108 is as depicted in FIG. 2, an aperture at diffusing vent 208 and/or air intake 204 may be opened and fan may be activated, causing airflow from air intake 204 to diffusing vent 208 to carry scent molecules out into the air, so that user may smell them. In an alternative or additional embodiment, automatically activated scent diffuser 108 may include a scent-diffusing module coupled to, or incorporated into, a mobile device such as, without limitation, an electronic music playback device or a smart phone.

[0040] Referring again to FIG. 1, system 100 includes a control circuit 112. Control circuit 112 may include any electronic circuit that may be configured as described below; for instance, control circuit 112 may include a logic circuit incorporating one or more logic gates. Control circuit 112 may include a microprocessor, microcontroller, or any computing device as described below in reference to FIG. 5. As a non-limiting example, control circuit 112 may include a mobile computing device such as a “smartphone” or the like. Control circuit 112 may be communicatively connected to automatically activated scent diffuser 108 and/or at least a physiological sensor 104, where “communicative connec-

tion” is defined as a relationship between two or more devices or components whereby the two or more devices or components are capable of sending and/or receiving electrical or wireless signals to and/or from each other; for instance, where automatically activated scent diffuser 108 includes a transceiver or other wireless communication device, control circuit 112 may include a transceiver or other wireless communication device capable of communication with the transceiver or other wireless communication device of the automatically activated scent diffuser 108. Alternatively or additionally, control circuit 112 may be connected to automatically activated scent diffuser 108 and/or other components via a wired connection, by way of one or more intermediate devices, or by incorporation in the same component, chip, or circuit as automatically activated scent diffuser 108. Control circuit 112 may be configured to perform any methods or method steps as disclosed herein in any combination, including without limitation method 400 as described in further detail below. As a non-limiting example, control circuit 112 may be configured to receive a detection signal from the at least a physiological sensor 104, determine that the user is entering a hypnagogic state, and transmit the electronic activation signal to the automatically activated scent diffuser 108, as described in further detail below.

[0041] Referring now to FIG. 3, an exemplary embodiment of a Pavlovian conditioned reflex sleep induction kit 300 is illustrated. In an embodiment, kit 300 includes at least a physiological sensor 104 configured to detect at least a physiological parameter of a user and transmit a detection signal; this may be implemented using any components, devices, or processes described above in reference to FIG. 1. Kit 300 includes an automatically activated scent diffuser 108 configured to receive an electronic activation signal and diffuse a scent, in response to the electronic activation signal; this may be implemented using any components, devices, or processes described above in reference to FIG. 1. Kit 300 includes a control circuit 112 configured to receive the detection signal from the at least a physiological sensor 104, determine that the user is entering a hypnagogic state, and transmit the electronic activation signal to the automatically activated scent diffuser 108. Control circuit 112 may be implemented and/or configured using any components, devices, or processes described above in reference to FIG. 1.

[0042] Still referring to FIG. 3, kit 300 includes a user-activated scent diffuser 304 that diffuses the scent upon activation by a user. User-activated scent diffuser 304 may include a scent diffuser that diffuses scent upon activation by user; activation by user, as used herein, means direct activation by a voluntary act on the part of the user, in a process that does not include sensing physiological parameters or determining a user state. For instance, user-activated scent diffuser 304 may include a switch that user turns on, causing release of scent, a manually activated opening 212, such as without limitation manually activated opening 212 depicted in FIG. 2, which exposes scent-diffusing material, a heat source such as a candle or an electric heater that user can apply to substance containing scent-diffusing material, a vibration-generating component to generate ultrasonic vibrations, or the like. User-activated scent diffuser 304 may include a container, such as a portable container, that user may open and/or close manually; container may be constructed of any suitable material, including plastic, paper, metal, wood, or the like. Container may have a form of a box

or wrapper that user opens to release scent. In a non-limiting example, user-activated scent diffuser 304 may include a container such as a box, wrapper, or sealed packet containing a scent wafer as described above, which user may activate by opening the container, and may deactivate by shutting or sealing the container. User-activated scent diffuser 304 may include any mechanism for scent diffusion and/or dispersal described above for automatically activated scent diffuser 108. User-activated scent diffuser 304 may be a separate device from automatically activated scent diffuser; alternatively, automatically activated scent diffuser 108 may function as user-activated scent diffuser by incorporation of one or more controls or features enabling user to activate scent diffusion, for example manually. Scent diffused by user-activated scent diffuser 304 may be identical, or substantially identical, to scent diffused by automatically activated scent diffuser 108. User-activated scent diffuser 304 may include a scent-diffusing module coupled to, or incorporated into, a mobile device such as, without limitation, a smart phone.

[0043] Referring now to FIG. 4, an exemplary embodiment of a method 400 of inducing a Pavlovian association of a scent with sleep initiation is illustrated. At step 405, control circuit 112 detects, using at least a physiological sensor 104, at least a physiological parameter of a user. Detection may be performed using any processes, process steps, and/or components, in any combination, as described above in reference to FIG. 1.

[0044] At step 410, and still referring to FIG. 4, control circuit 112 determines, as a function of the at least a physiological parameter, that the user is entering a hypnagogic state. A “hypnagogic state,” as used herein, is a state wherein a user is in the process of transitioning from waking to sleeping; a user in a hypnagogic state may be neither fully awake nor fully asleep. A hypnagogic state may be state of sleep latency, of imminent sleep, or the like. In an embodiment, detection of user entry into hypnagogic state enables control circuit 112 to target scent diffusion to that state, allowing a precise Pavlovian association between sleep entry and diffused scent to be established; this may be crucial to avoid incorrect associations being formed with, for example, wakefulness, including even drowsy wakefulness under circumstances in which user is trying and failing to fall asleep, or with a state after user has fallen asleep.

[0045] In an embodiment, and still viewing FIG. 4, determining that user is entering a hypnagogic state may further include determining that at least a physiological parameter indicates a state of pre-sleep relaxation, and estimating a time from pre-sleep relaxation to a hypnagogic state. Indication of pre-sleep relaxation may include detection of a change in neural oscillations, such as a detection of decreasing alpha waves, also known as Berger’s waves (neural oscillations in the range of 7.5-12.5 Hertz); as a further non-limiting example, an increase in beta waves, characterized by frequencies on the order of 13-30 Hertz may be an indication of pre-sleep relaxation. Detection of delta waves, having frequencies ranging from 1-4 Hertz, may alternatively or additionally indicate entry into pre-sleep relaxation. Similarly, a decrease in heart rate, pulse rate, blood pressure, a change in Heart Rate Variability pattern, or another cardiovascular indicator may be compared with values associated with pre-sleep relaxation. In an embodiment, control circuit 112 may track patterns of physiological parameters and timing thereof relative to entry into an identifiable sleep

stage. Thus, for instance, a detection of non-REM sleep, REM sleep, or other sleep stages as described below may be used to identify a moment that user has fallen asleep; patterns of physiological indicators such as neural oscillations and/or heart rate, including without limitation heart rate variability (HRV) patterns, may be associated with a time proximal to such detection and may be recorded in memory of control circuit 112. Patterns may be detected by any suitable method for detection of statistical or mathematical relationships, including without limitation machine-learning algorithms such as linear or polynomial regression algorithms. Patterns may be detected using data of a particular user associated with a particular implementation of system 100, and/or using data of multiple users. Control circuit 112 may include, in memory of control circuit 112, an average time from detection of indication of pre-sleep relaxation to detection of entry into a sleep state; average time may be calculated using any modeling or statistical correlation program suitable for detection of patterns of at least a physiological parameter associated with pre-sleep relaxation. In an embodiment, entry into a hypnagogic state may be estimated as occurring at a point between indication of pre-sleep relaxation and a time average time after indication of entry into sleep state, including without limitation a time just before predicted time of entry into sleep state.

[0046] Continuing to view FIG. 4, in an embodiment, determining that the user is entering a hypnagogic state may include detecting a first physiological parameter of the at least a physiological parameter at a first time, detecting a second physiological parameter of the at least a physiological parameter at a second time subsequent to the first time, and determining that the second physiological parameter indicates a greater degree of relaxation than the first physiological parameter. Each of first physiological parameter and second physiological parameter may include any physiological parameter as described above in reference to FIGS. 1-3, including without limitation neural oscillations, heart rate, heart rate variability (HRV) patterns, breathing rate, and the like. Association of first physiological parameter and second physiological parameter with greater and/or lesser degrees of relaxation may be determined using any method as described above; a greater degree of relaxation, for instance, may be associated with a physiological parameter typically detected closer in time to detection of a sleep state, while a lesser degree of relaxation may be associated with a physiological parameter typically detected a greater amount of time prior to detection of a sleep state. As a non-limiting, illustrative example, a decrease in alpha waves may typically be detected ten minutes before detection of a sleep state, while an increase in beta waves may typically be detected five minutes before detection of a sleep state; delta waves may typically be detected two minutes before detection of sleep state. This process may be repeated more than once, with more than one physiological parameter functioning as first or second physiological parameter in the above example.

[0047] In an embodiment, and continuing to refer to FIG. 4, detection of entry into hypnagogic state may include detection of a physiological parameter correlated with entry into hypnagogic state. For instance, where a physiological parameter is nearly always detected as occurring just before detection of a sleep state, such as delta wave activity beginning two minutes before detection of non-REM sleep, determination of entry into hypnagogic state may include

detection of physiological parameter and identification of entry into hypnagogic state at the time of detection.

[0048] Still referring to FIG. 4, determination that user is entering hypnagogic state may include one or more determinations that user is in a sleep state; for instance, as noted above determination of sleep states on earlier occasions may be used to estimate a moment of entry into a hypnagogic state, or to identify a physiological indicator consistent with entry into a hypnagogic state. In embodiment, determination of sleep phase by monitoring an individual during sleep may be referred to as sleep staging. Sleep staging may be performed, as a non-limiting example using the traditional Rechtschaffen & Kales rules, which classify sleep into six separate stages: wake, rapid eye movement (REM) sleep, S1 (light sleep), S2 (light sleep), S3 (deep sleep), and S4 (deep sleep). Alternative systems for sleep staging may be known to persons skilled in the art. Techniques for monitoring physiological changes associated with different stages of sleep may include, without limitation, EEG recordings of brain activity, EOG recordings of eye movement and ocular muscle contractions, EKG recordings of heart beats, heart rate variability, heart rate or heart rate entropy, respiratory rate, body temperature, eye or body movements (actigraphy). As a non-limiting example, relationships between cardiovascular activity and particular sleep stages may be used to identify sleep stages. Physiological interconnections between user's central nervous system and the autonomic nervous system, such as autonomic cardiovascular control at the sinus node level may permit analysis concerning sleep structure based, as a non-limiting example, on noninvasive analysis of heart rate variability, as detected from the electrocardiogram. Moreover, morphological changes in the cardiac electrical complex may occur during respiratory cycles and body position changes. Power spectral analysis of instantaneous heart rate fluctuations may be used to record and/or track three components: high frequency, low frequency and very low frequency, which may be correlates of autonomic nervous system function. Time frequency decomposition of these fluctuations may permit identification of transient physiological phenomena as they occur during sleep or wakefulness. Such components may display differential profiles in the different sleep stages, allowing for classification of sleep stages from an EKG.

[0049] Continuing to view FIG. 4, and as a further non-limiting example, REM sleep may be identified using measurement of eye movements; eye movements as detected using EOG data and/or video footage of eye movements may be compared to eye movements associated with REM sleep. EEG or other neural oscillation data may be used to identify a sleep state; for instance, a high degree of delta-wave activity may be associated with deeper sleep stages, as may a cessation or marked reduction in alpha waves and/or beta waves. Sleep state may further be estimated by one or more additional physiological parameters in combination. For instance, sleep state may be identified using a combination of motion detection, heart rate, heart rhythm, heart rate variability pattern, heart electrophysiologic pattern or motion signature, blood oxygen saturation, temperature, skin temperature, body position, breathing rhythms and/or respiration rate, audio patterns including detection of snoring, and/or skin conductance. Association of one or more physiological parameters with a sleep state may be programmed into memory of control circuit 112 and/or received from another device. Alternatively or additionally, control

circuit 112 may associate one or more physiological parameters with sleep state in a similar manner to methods for determining associations described above; for instance, eye-motion detection may determine that user is in REM sleep, and state of physiological parameters at detection of eye motion correlated with REM sleep may be tracked and used to create further associations.

[0050] At step 415, and still viewing FIG. 4, control circuit 112 triggers a release of a scent; this may be performed using automatically activated scent diffuser 108, using any component, process step, or combination thereof described above in reference to FIGS. 1-3. In an embodiment, scent is not released until triggering; for instance automatically activated scent diffuser 108 may allow no scent, or substantially no scent, to be released and/or detected except upon receipt of electronic activation signal. In an embodiment, this may ensure that user establishes a Pavlovian correlation between scent and sleep entry; where user is exposed to scent only upon entry into hypnagogic state, user may develop a strong Pavlovian association between scent and the act of falling asleep. This may ensure that future exposure to scent will cause user to fall asleep more quickly. In an embodiment, control circuit may detect that user has entered a sleep state and deactivate automatically activated scent diffuser 108. Alternatively or additionally, control circuit 112 may determine that a time limit has passed and deactivate the automatically activated scent diffuser 108 as a function of the determination. Time limit may be calculated from any suitable event, including activation or entry into a sleep stage such as light sleep, REM sleep, and/or deep sleep, detected as described above. Deactivation may, in an embodiment, prevent Pavlovian association of the smell with waking or other events besides falling asleep.

[0051] In operation, and still viewing FIG. 4, method may involve a first period in which steps 405-415 are followed iteratively; for instance, system 100 may be used on a nightly basis for a number of nights to administer scent to user at entry into hypnagogic state, creating an association, via classical conditioning, between the scent and the moment of entry into sleep. User may then employ kit 300 to aid in sleeping; for instance, user may take user-activated scent diffuser 304 while traveling and, at a moment user wishes to sleep, may position user-activated scent diffuser 304 near user and activate scent diffusion. Pavlovian association between scent and sleep entry may cause user to fall asleep more readily than would otherwise be possible, particularly in unfamiliar settings. Kit 300 may advantageously prevent user from having to carry and/or use sensors or other materials; for instance, sensors may be distracting under circumstances where sleep is more difficult, reducing the effectiveness of Pavlovian association, however user may employ system 100 to create the Pavlovian association under ideal sleep circumstances, or on days on which user is especially tired and likely to fall asleep, and then may use kit 300 and/or user-activated scent diffuser 304 to aid in sleeping in more difficult situations. User-activated scent diffuser 304 may require no electricity in an embodiment; as a result, user may be able to carry and use it in situations where electrical power is limited or not present, such as on camping trips or during emergencies or extreme weather events. In addition, the user-activated scent diffuser 304 may enable the user to avoid carrying additional electrical cords, connectors, chargers and electrical plugs including those necessary for use with different international voltages. User-

activated scent diffuser **304** may similarly be used in circumstances where electronic devices and/or wireless communication may be restricted, such as airplanes or hospital rooms.

[0052] It is to be noted that any one or more of the aspects and embodiments described herein may be conveniently implemented using one or more machines (e.g., one or more computing devices that are utilized as a user computing device for an electronic document, one or more server devices, such as a document server, etc.) programmed according to the teachings of the present specification, as will be apparent to those of ordinary skill in the computer art. Appropriate software coding can readily be prepared by skilled programmers based on the teachings of the present disclosure, as will be apparent to those of ordinary skill in the software art. Aspects and implementations discussed above employing software and/or software modules may also include appropriate hardware for assisting in the implementation of the machine executable instructions of the software and/or software module.

[0053] Such software may be a computer program product that employs a machine-readable storage medium. A machine-readable storage medium may be any medium that is capable of storing and/or encoding a sequence of instructions for execution by a machine (e.g., a computing device) and that causes the machine to perform any one of the methodologies and/or embodiments described herein. Examples of a machine-readable storage medium include, but are not limited to, a magnetic disk, an optical disc (e.g., CD, CD-R, DVD, DVD-R, etc.), a magneto-optical disk, a read-only memory “ROM” device, a random access memory “RAM” device, a magnetic card, an optical card, a solid-state memory device, an EPROM, an EEPROM, and any combinations thereof. A machine-readable medium, as used herein, is intended to include a single medium as well as a collection of physically separate media, such as, for example, a collection of compact discs or one or more hard disk drives in combination with a computer memory. As used herein, a machine-readable storage medium does not include transitory forms of signal transmission.

[0054] Such software may also include information (e.g., data) carried as a data signal on a data carrier, such as a carrier wave. For example, machine-executable information may be included as a data-carrying signal embodied in a data carrier in which the signal encodes a sequence of instruction, or portion thereof, for execution by a machine (e.g., a computing device) and any related information (e.g., data structures and data) that causes the machine to perform any one of the methodologies and/or embodiments described herein.

[0055] Examples of a computing device include, but are not limited to, an electronic book reading device, a computer workstation, a terminal computer, a server computer, a handheld device (e.g., a tablet computer, a smartphone, etc.), a web appliance, a network router, a network switch, a network bridge, any machine capable of executing a sequence of instructions that specify an action to be taken by that machine, and any combinations thereof. In one example, a computing device may include and/or be included in a kiosk.

[0056] FIG. 5 shows a diagrammatic representation of one embodiment of a computing device in the exemplary form of a computer system **500** within which a set of instructions for causing a control system, to perform any one or more of the

aspects and/or methodologies of the present disclosure may be executed. It is also contemplated that multiple computing devices may be utilized to implement a specially configured set of instructions for causing one or more of the devices to perform any one or more of the aspects and/or methodologies of the present disclosure. Computer system **500** includes a processor **504** and a memory **508** that communicate with each other, and with other components, via a bus **512**. Bus **512** may include any of several types of bus structures including, but not limited to, a memory bus, a memory controller, a peripheral bus, a local bus, and any combinations thereof, using any of a variety of bus architectures.

[0057] Memory **508** may include various components (e.g., machine-readable media) including, but not limited to, a random-access memory component, a read only component, and any combinations thereof. In one example, a basic input/output system **516** (BIOS), including basic routines that help to transfer information between elements within computer system **500**, such as during start-up, may be stored in memory **508**. Memory **508** may also include (e.g., stored on one or more machine-readable media) instructions (e.g., software) **520** embodying any one or more of the aspects and/or methodologies of the present disclosure. In another example, memory **508** may further include any number of program modules including, but not limited to, an operating system, one or more application programs, other program modules, program data, and any combinations thereof.

[0058] Computer system **500** may also include a storage device **524**. Examples of a storage device (e.g., storage device **524**) include, but are not limited to, a hard disk drive, a magnetic disk drive, an optical disc drive in combination with an optical medium, a solid-state memory device, and any combinations thereof. Storage device **524** may be connected to bus **512** by an appropriate interface (not shown). Example interfaces include, but are not limited to, SCSI, advanced technology attachment (ATA), serial ATA, universal serial bus (USB), IEEE 1394 (FIREWIRE), and any combinations thereof. In one example, storage device **524** (or one or more components thereof) may be removably interfaced with computer system **500** (e.g., via an external port connector (not shown)). Particularly, storage device **524** and an associated machine-readable medium **528** may provide nonvolatile and/or volatile storage of machine-readable instructions, data structures, program modules, and/or other data for computer system **500**. In one example, software **520** may reside, completely or partially, within machine-readable medium **528**. In another example, software **520** may reside, completely or partially, within processor **504**.

[0059] Computer system **500** may also include an input device **532**. In one example, a user of computer system **500** may enter commands and/or other information into computer system **500** via input device **532**. Examples of an input device **532** include, but are not limited to, an alpha-numeric input device (e.g., a keyboard), a pointing device, a joystick, a gamepad, an audio input device (e.g., a microphone, a voice response system, etc.), a cursor control device (e.g., a mouse), a touchpad, an optical scanner, a video capture device (e.g., a still camera, a video camera), a touchscreen, and any combinations thereof. Input device **532** may be interfaced to bus **512** via any of a variety of interfaces (not shown) including, but not limited to, a serial interface, a parallel interface, a game port, a USB interface, a FIREWIRE interface, a direct interface to bus **512**, and any

combinations thereof. Input device 532 may include a touch screen interface that may be a part of or separate from display 536, discussed further below. Input device 532 may be utilized as a user selection device for selecting one or more graphical representations in a graphical interface as described above.

[0060] A user may also input commands and/or other information to computer system 500 via storage device 524 (e.g., a removable disk drive, a flash drive, etc.) and/or network interface device 540. A network interface device, such as network interface device 540, may be utilized for connecting computer system 500 to one or more of a variety of networks, such as network 544, and one or more remote devices 548 connected thereto. Examples of a network interface device include, but are not limited to, a network interface card (e.g., a mobile network interface card, a LAN card), a modem, and any combination thereof. Examples of a network include, but are not limited to, a wide area network (e.g., the Internet, an enterprise network), a local area network (e.g., a network associated with an office, a building, a campus or other relatively small geographic space), a telephone network, a data network associated with a telephone/voice provider (e.g., a mobile communications provider data and/or voice network), a direct connection between two computing devices, and any combinations thereof. A network, such as network 544, may employ a wired and/or a wireless mode of communication. In general, any network topology may be used. Information (e.g., data, software 520, etc.) may be communicated to and/or from computer system 500 via network interface device 540.

[0061] Computer system 500 may further include a video display adapter 552 for communicating a displayable image to a display device, such as display device 536. Examples of a display device include, but are not limited to, a liquid crystal display (LCD), a cathode ray tube (CRT), a plasma display, a light emitting diode (LED) display, and any combinations thereof. Display adapter 552 and display device 536 may be utilized in combination with processor 504 to provide graphical representations of aspects of the present disclosure. In addition to a display device, computer system 500 may include one or more other peripheral output devices including, but not limited to, an audio speaker, a printer, and any combinations thereof. Such peripheral output devices may be connected to bus 512 via a peripheral interface 556. Examples of a peripheral interface include, but are not limited to, a serial port, a USB connection, a FIREWIRE connection, a parallel connection, and any combinations thereof.

[0062] FIG. 6 illustrates another embodiment of the automatically activated scent diffuser 108. The system preferably comprises a generally rectangular lower housing portion 201 which includes a compartment 203 for standard alkaline batteries such as size AA batteries, and an upper housing portion 202 which encloses circuitry and a mounting collar or bottle holder 205 for receiving a generally cylindrical bottle 206 adapted to contain a fragrance fluid. Preferably, a lower peripheral rim 222 of the upper housing portion 202 mates with an upper peripheral rim 221 of the lower housing portion 201, and the two housing portions are secured together by screws, threaded through horizontal flanges 209 formed at respective corners of the peripheral rims. It will be apparent that alternative securing structures can be substituted for the screws, by those having ordinary skill in the art.

[0063] The circuitry mounted in the upper housing portion 202 suitably comprises a voltage regulator 224 (e.g. model D24V10F5 available from Pololu Corp of Las Vegas Nev., USA), a communications module, for example a BLUETOOTH transceiver 226 (such as SparkFun model nRF52832, available from SparkFun Electronics of Niwot, Colo., USA), an ultrasonic transducer PCB (printed circuit board) 228, a solenoid or linear actuator 230, and a solenoid control circuit 232 (available from Ecom of Rehovot, Israel). As in the case of ultrasonic transducers used in home humidifiers, PCB 228 drives a generally annular ultrasonic transducer arranged at an outlet opening of the bottle 205 of fragrance fluid; the transducer serves to nebulize the fluid, in order to emit the fragrance into the ambient air surrounding the user of the diffuser. Also mounted in upper housing portion 202 is the bottle holder 205 for receiving the bottle 206 of fragrance fluid. On top of the bottle holder, there is pivotably secured a horizontally oriented shutter 234, formed with a vertical bore or hole 236. Horizontally oriented shutter 234 is mounted at a corner thereof for rotation on a vertically aligned solenoid pin 237, so that shutter 234 can be rotated, for example about 90 degrees, alternately in a first rotation direction and in a second rotation direction. The solenoid 230 is mechanically coupled to the shutter 234, so that the shutter serves as a valve, opening the bottle when the hole 236 in the shutter is aligned with a central opening 246 at the top of the bottle, and closing the bottle when the hole 236 has been pivoted sideways, out of alignment with the bottle central opening 246. Alternatively, the shutter can be pivoted by an electric servo motor (such as model FS90, available from FeeTech RC Model Co. Ltd. of Shenzhen China).

[0064] FIG. 7 is a side view of the diffuser, showing the housing portions in phantom, in order to show an exemplary configuration of the bottle 205, the bottle holder 206 and the respective circuit boards.

[0065] FIGS. 8A and 8B show, respectively, the diffuser exterior and the diffuser interior when the shutter 234 is aligned to open the bottle 205. FIGS. 9A and 9B show, respectively, the diffuser exterior and diffuser interior when shutter 234 is aligned to close bottle 205 by presenting a solid portion of shutter 234 to the central opening 246 of bottle 205. For example, as shown in FIG. 8B, shutter 234 can have a generally triangular shape with a pivot point at one vertex, subtending an angle of 60 degrees. Hole 236 can be formed near an edge of the triangle, remote from the pivot point. Rotating shutter 234 by 20 degrees or so, for example counterclockwise (viewed from above as in FIG. 9B) brings hole 236 out of alignment with opening 246 of bottle 205, thereby bringing a solid portion of shutter 234 adjacent to opening 246, and closing bottle 205.

[0066] FIG. 10A and FIG. 10B respectively show how solenoid 230 actuates shutter 234 to switch between a first, bottle-open, configuration and a second, bottle-closed, configuration. A coupling between solenoid 230 and shutter 234 includes a vertically aligned central pin 239 and a vertically aligned solenoid pin 237. The pins are each received within a respective cylindrical sleeve, and the sleeves are rigidly connected to each other by a horizontal bridge 238. A lower end of solenoid pin 237 is received in a vertical bore formed in solenoid piston or plunger 240. Energizing the coil within solenoid 230 retracts piston 240, causing it to exert a pulling force as shown by the arrow in FIG. 10A. An annular stop 241 on the exterior of piston 240 limits the distance that the

piston can travel, because stop **241** comes into abutment with an end face of solenoid **230**, as may be seen by comparing FIG. **10B** (extended) with FIG. **10A** (retracted). Central pin **239** is fixed in a portion of bottle holder **205**, so bridge **238** causes the sleeve around pin **239** to rotate, and shutter **234** rotates clockwise until shutter hole **236** is vertically aligned with bottle opening **246**, allowing scented fluid to be released from the bottle. Conversely, when solenoid **230** is de-energized, piston **240** moves outwardly with respect to solenoid **230**, as shown by the arrow in FIG. **10B**, and bridge **238** transmits this motion to the sleeve surrounding central pin **239**, causing shutter **234** to rotate counter-clockwise, thereby closing bottle **206** and stopping release of scented fluid. Bottle **206** is preferably somewhat tapered, larger in diameter near the bottom, and formed near its top with a radially projecting annular collar **217**, beneath which is an annular groove or recess **219**, to facilitate secure gripping by bottle holder **205**.

[0067] FIG. **11A** is a slightly enlarged view similar to FIG. **10B**, showing a flat vertical side face of solenoid **230**, adapted for fastening to a vertical sidewall in the diffuser. FIG. **11B** is a view of the same structure, rotated 180 degrees, to show mechanical connections between bottle holder **205** and solenoid **230**.

[0068] FIG. **12** is an exploded view, showing components which are assembled to couple bottle holder **205** and solenoid **230** together and to perform fragrance release functions. Bottle holder **205** is preferably a molded plastic element, forming a hollow vertical cylinder with a plurality of depending latches or claws **213** which in vertical cross-section are L-shaped, for example three claws spaced at 120 degree circumferential intervals. The claws point radially inward and are radially resilient, so that a bottle **206** can be inserted axially upwardly into holder **205**, and the claws will bow outward momentarily, slide across collar **217** of the bottle, and snap-fit into annular groove **219**, thereby holding bottle **206** securely, even if the entire diffuser structure is subsequently vibrated or moved from place to place.

[0069] Holder **205** is preferably formed with a laterally projecting U-shaped channel **225** adapted to secure solenoid **230** within it. As shown, channel **225** preferably has a horizontal top wall, a horizontal bottom wall, and a connecting vertical sidewall which interconnects the top & bottom walls, at wall edges remote from the hollow cylindrical portion. Channel **225** is dimensioned to snugly receive solenoid **230** between its top & bottom walls, and against its sidewall. Preferably, respective holes are formed in the top wall and in a top wall of solenoid **230**, so that a pair of screws **227** can be inserted through the top wall and into solenoid **230**, to thereby secure solenoid **230** within channel **225**.

[0070] In order to facilitate evaporation and dispersion of scented fluid from bottle **206**, a generally disk-shaped ultrasonic transducer **248** is provided, dimensioned to be received within holder **205**. Such ultrasonic transducers are widely used in residential humidifying devices, and suitable models are well known to those having ordinary skill in the air treatment and fragrance dispensing arts. As previously mentioned, the transducer is suitably driven by a transducer driving circuit board **228**. Optionally, a fan can be provided to help disperse scent droplets produced by the ultrasonic transducer. A coil spring **250** is placed on top of transducer **248**. A leading tube **252** with a top annular flange is placed on top of spring **250**, so that spring **250** can urge leading tube

252 upward toward shutter **234**. This tends to minimize leakage of volatile components of the fragrance fluid from bottle **206** at times when dispensing is not intended. As previously mentioned, a central pin **239** rides within a cylindrical sleeve which is secured to a bottom surface of shutter **234**, and a solenoid pin **237** rides within another cylindrical sleeve connected by a bridge **238** to the central pin's sleeve.

[0071] FIG. **13** is a view, partly in cross-section, showing the components of FIG. **12** in an assembled state, ready for operation.

[0072] Sleep scientists recognize nine sequential electroencephalographic (EEG) stages of sleep. See Tanaka et al., *Statistical Features of Hypnagogic EEC Measured by a New Scoring System*, published 1976 in the academic journal *Sleep*, 19(9): 731-738. Preferred methods of "scoring," or distinguishing between, sleep stages have been defined by the American Academy of Sleep Medicine (AASM), presently located in Darien, Ill., USA.

[0073] According to a first embodiment of the conditioning method of the present invention, using electroencephalogram (EEG) sensors, the user applies EEG electrodes to the head, and lies down to go to sleep. Signals from the EEG electrodes are fed to a computing device, for example to a smart mobile phone running the Apple operating system iOS or the Android operating system. Upon detection of EEG stage 1 (continuous train of alpha waves having a minimum amplitude of 20 microvolts), an electronic activation signal is sent, for example using the BLUETOOTH communications protocol or the ANT+ protocol of Garmin Canada, to automatic scent diffuser **108**, causing solenoid **230** to place shutter **234** in a bottle-open configuration (FIGS. **8A**, **10A**) and causing transducer circuit **228** to operate transducer **248** to nebulize fragrance fluid coming from bottle **206**. Optionally, faster diffusion can be obtained by turning on a small fan (not shown) adjacent to transducer **248**. The diffusion of fragrance continues as the user progresses into EEG stages 2 and 3. Typically, a user will be in stage 2 (alpha waves intermittent but still present for more than 50% of a sampling period) for about three and one half minutes. Upon detection of a beginning of sleep stage 3 (alpha waves intermittent but now present for less than 50% of a sampling period), a countdown timer is set for generation of a deactivation signal to the automatic scent diffuser. As in the case of the activation signal, the deactivation signal is preferably sent via BLUETOOTH or ANT+. Preferably, the countdown timer is set to generate the deactivation signal a predetermined period, e.g. 30 seconds, after the start of sleep stage 3. Alternatively, the duration of the predetermined period can be selected by consulting a lookup table, which associates a particular predetermined characteristic of the user with a respective duration. Upon receipt by diffuser **108** of the deactivation signal, ultrasonic transducer is turned off and solenoid **230** closes shutter **234** (FIG. **10B**), stopping release of fragrance fluid. Since the user is now in a state less susceptible to perception of the fragrance (and thus association of fragrance with sleep), cessation of fragrance emission tends to conserve fragrance fluid until a subsequent falling-asleep session. Preferably, if the user spontaneously awakens during the same night, a new conditioning session is performed. Preferably, at least one conditioning session is conducted on each of a plurality of successive days. Thereby, the user becomes conditioned to relax and fall asleep, each time the fragrance is perceived. Scholars Fujii-

wara et al., in an article entitled Heart Rate Variability-Based Driver Drowsiness Detection and its Validation with EEG, IEEE Transactions on Biomedical Engineering, Vol. 66, No. 6, pages 1769-1778, June 2019, disclose a suitable program for processing EEG sensor data to detect transitions between sleep states.

[0074] According to a second embodiment of the method of the invention, using electrocardiogram (ECG) sensors, the AASM (American Academy of Sleep Medicine) sleep states (wake, Rapid Eye Movement (REM) sleep, and 3 levels of non-REM sleep: NREM1, NREM2, NREM3) are distinguished, using signals from a commercially available fitness sensor, such as the POLAR model H10 which is typically sold with a chest strap. The model H10 is currently available from Polar Electro Inc., located at 15 Grumman Road West, Suite 1200, Bethpage, N.Y. 11714, USA. Other suitable sensors are known to those having ordinary skill in the sleep-stage monitoring art. For simplicity, the non-REM states NREM1, NREM2 and NREM3 are also referred to as "N1, N2, N3." The so-called "RR" intervals between heartbeats are very accurately detected by capturing the signals from the wearable ECG sensors, in order to analyze Heart Rate Variability (HRV). HRV and related parameters (preferably blood pressure and blood vessel size) are processed, to detect physiological changes in the sensor wearer, corresponding to an early N1 sleep state. Detection of that HRV pattern causes activation of the bedside automatic scent diffuser (by a signal sent from a suitable app running on a smart phone, linked to the sensor using the BLUETOOTH protocol or the ANT+ protocol). The activation is maintained for a period of 10 minutes, corresponding to the early N1 state. When 10 minutes has elapsed since sending of the activation signal, a deactivation signal is sent from the app running on the smart phone. For example, the Polar Electro company of Bethpage N.Y. offers a smartphone app under the mark BEAT (US Reg. #2,034,443). Suitable sensor structures are disclosed in one or more of Polar Electro's U.S. Pat Nos. 10,064,581; 10,070,798; 10,146,297; 10,154,129; 10,313,420; 10,314,506; 10,335,636 and US published application 2019-0254524. Automated sleep stage classification using heart rate variability is described in the 12 Sep. 2018 article of Radha et al., entitled LSTM Knowledge Transfer for HRV-based Sleep Staging, arXiv: 1809.06221v1.

[0075] The foregoing has been a detailed description of illustrative embodiments of the invention. Various modifications and additions can be made without departing from the spirit and scope of this invention. Features of each of the various embodiments described above may be combined with features of other described embodiments, as appropriate, in order to provide a multiplicity of feature combinations in associated new embodiments. Furthermore, while the foregoing describes a number of separate embodiments, what has been described herein is merely illustrative of the application of the principles of the present invention. Additionally, although particular methods herein may be illustrated and/or described as being performed in a specific order, the ordering is highly variable within ordinary skill to achieve methods, systems, and software according to the present disclosure. Accordingly, this description is meant to be taken only by way of example, and not to otherwise limit the scope of this invention.

1. A method of inducing a Pavlovian association of a scent with sleep initiation, the method comprising:

- detecting, by a control circuit using at least a physiological sensor, at least a physiological parameter of a user;
 - determining, by the control circuit and as a function of the detected a physiological parameter, a user's entry into a sleep cycle is imminent, wherein the determining comprises comparing the detected physiological parameter to a physiological indicator associated with the user; and
 - triggering, by the control circuit and using a scent diffuser controlled by the logic circuit, a release of a scent when the user's entry into the sleep cycle is determined to be imminent.
2. The method of claim 1, wherein determining that the user is entering a hypnagogic state further comprises:
- determining that the at least a physiological parameter indicates a state of pre-sleep relaxation; and
 - estimating a time from pre-sleep relaxation to a hypnagogic state.
3. The method of claim 1, wherein determining that the user is entering a hypnagogic state further comprises:
- detecting a first physiological parameter of the at least a physiological parameter at a first time;
 - detecting a second physiological parameter of the at least a physiological parameter at a second time subsequent to the first time; and
 - determining that the second physiological parameter indicates a greater degree of relaxation than the first physiological parameter.
4. (Canceled)
5. The method of claim 1, wherein the scent is not released until triggering.
6. The method of claim 1 further comprising deactivating, by the control circuit, the scent diffuser.
7. The method of claim 6 further comprising:
- ascertaining, by the control circuit, that the user has entered the sleep cycle; and
 - deactivating the scent diffuser as a function of the ascertainment.
8. The method of claim 6 further comprising:
- determining, by the control circuit, that a time limit has passed after triggering the release of the scent; and
 - deactivating the automatically activated scent diffuser as a function of the determination.
9. A system for inducing a Pavlovian conditioned reflex association of a scent with sleep initiation, the system comprising:
- a physiological sensor, wherein the physiological sensor is configured to detect at least a physiological parameter of a user and to transmit a detection signal, said detection signal including the detected physiological parameter;
 - an automatically activated scent diffuser, wherein the automatically activated scent diffuser is configured to receive an electronic activation signal and diffuse a scent as a function of the electronic activation signal; and
 - a control circuit configured to receive the detection signal from the at least a physiological sensor, determine, as a function of the received detection signal, that a user's entry into a sleep cycle is imminent, wherein the determining comprises comparing the detected physiological parameter to a physiological indicator associated with the user, and transmit the electronic activation

- signal to the automatically activated scent diffuser when the user's entry into the sleep cycle is determined to be imminent.
10. The system of claim 9, wherein the physiological sensor includes at least an electrophysiologic sensor.
11. The system of claim 10, wherein the at least an electrophysiologic sensor includes an electrocardiogram.
12. The system of claim 10, wherein the at least an electrophysiologic sensor includes an electroencephalogram.
13. The system of claim 9, wherein the physiological sensor includes a body temperature sensor.
14. The system of claim 9, wherein the physiological sensor includes a motion sensor.
15. The system of claim 9, wherein the physiological sensor is incorporated in a wearable device.
16. (canceled)
17. The system of claim 9, wherein the automatically activated scent diffuser includes an aperture with an electronically activated door.
18. The system of claim 9, wherein the automatically activated scent diffuser is further configured to stop diffusing the scent, upon reception of a deactivation signal.
19. The system of claim 18, wherein the control circuit is further configured to transmit, to the automatically activated scent diffuser, the deactivation signal.
20. A Pavlovian conditioned reflex sleep induction kit, the kit comprising:
 a physiological sensor, wherein the at least a physiological sensor is configured to detect at least a physiological parameter of a user and transmit a detection signal, said detection signal indicating the physiological parameter of the user;
- an automatically activated scent diffuser, wherein the automatically activated scent diffuser is configured to receive an electronic activation signal and diffuse a scent as a function of the electronic activation signal; a control circuit configured to receive the detection signal from the physiological sensor, determine, as a function of the received detection signal, that a user's entry into a sleep cycle is imminent, wherein the determining comprises comparing the detected physiological parameter to a physiological indicator associated with the user, and to transmit the electronic activation signal to the automatically activated scent diffuser when the user's entry into the sleep cycle is determined to be imminent; and
 a user-activated scent diffuser that diffuses the scent upon activation by a user.
21. The method of claim 6, wherein said triggering step comprises detecting signals indicative of entry into early sleep stage N1, and, in response thereto, triggering scent diffusion, and
 said deactivating step comprises detecting signals indicative of a transition from sleep stage 2 into sleep stage 3 and, a predetermined period of time thereafter, deactivating scent diffusion.
22. The method of claim 6, wherein said triggering step comprises detecting electrocardiogram (ECG) signals indicative of an early N1 state and, in response thereto, triggering scent diffusion, and said deactivating step comprises measuring passage of a predetermined period of time after said activating step, and then deactivating scent diffusion.
23. The method of claim 22, wherein said predetermined period of time is 10 minutes.
- * * * * *

专利名称(译)	帕夫洛夫睡眠诱导的方法和系统		
公开(公告)号	US20200129727A1	公开(公告)日	2020-04-30
申请号	US16/568627	申请日	2019-09-12
发明人	LAZAROVICH, MARK		
IPC分类号	A61M21/02 A61B5/00 A61B5/01		
CPC分类号	A61B5/01 A61M2230/18 A61M21/02 A61B5/6803 A61M2021/0016 A61B5/4812 A61B5/4809 A61M2230/04 A61B5/0006 A61B5/4818 A61M2230/10 A61B5/0205 A61B5/02405 A61B5/1118 A61B5/165 A61B5/4836 A61M11/005 A61M11/042 A61M2205/3375 A61M2205/3553 A61M2205/3569 A61M2205/3584 A61M2205/3592 A61M2205/505 A61M2205/8206 A61M2209/06 A61M2230/14 A61M2230/205 A61M2230/30 A61M2230/50 A61M2230/63 A61M2230/65 A61M2230/005		
优先权	62/749746 2018-10-24 US		
外部链接	Espacenet USPTO		

摘要(译)

一种巴甫洛夫病条件反射睡眠诱导套件，包括至少一个生理传感器，其中所述至少一个生理传感器被配置为检测用户的至少生理参数并将检测信号传输到自动激活的香气扩散器，其中所述自动激活的香气扩散器扩散器被配置为接收电子激活信号并根据电子激活信号来扩散气味，控制电路被配置为从至少一个生理传感器接收检测信号，以确定用户正在进入催眠状态，并将电子激活信号传输到自动激活的气味扩散器，从而调节用户以响应随后对相同气味的感测。为了以后使用，提供了用户激活的气味扩散器，其在用户激活时扩散相同的气味，从而触发条件反射使其入睡。

