



(19) **United States**

(12) **Patent Application Publication**  
**IMAJO et al.**

(10) **Pub. No.: US 2018/0120937 A1**  
(43) **Pub. Date: May 3, 2018**

(54) **INTERNAL DEVICE OF BRAIN-MACHINE INTERFACE SYSTEM INCLUDING NOISE REDUCTION TECHNIQUE, AND METHOD OF CONTROLLING THE INTERNAL DEVICE**

**Publication Classification**

(51) **Int. Cl.**  
*G06F 3/01* (2006.01)  
*A61B 5/0478* (2006.01)  
*A61B 5/00* (2006.01)  
*A61B 5/04* (2006.01)  
(52) **U.S. Cl.**  
CPC ..... *G06F 3/015* (2013.01); *A61B 5/0478* (2013.01); *A61B 5/0006* (2013.01); *A61B 5/04012* (2013.01); *A61B 5/04012* (2013.01); *A61B 5/6868* (2013.01); *A61B 5/7203* (2013.01)

(71) Applicants: **NIHON KOHDEN CORPORATION**, Tokyo (JP); **OSAKA UNIVERSITY**, Osaka (JP); **NATIONAL INSTITUTE OF INFORMATION AND COMMUNICATIONS TECHNOLOGY**, Tokyo (JP)

(72) Inventors: **Kaoru IMAJO**, Tokyo (JP); **Katsuyoshi SUZUKI**, Tokyo (JP); **Masayuki HIRATA**, Osaka (JP); **Seiji KAMEDA**, Osaka (JP); **Takafumi SUZUKI**, Tokyo (JP); **Hiroshi ANDO**, Tokyo (JP)

(73) Assignees: **NIHON KOHDEN CORPORATION**, Tokyo (JP); **OSAKA UNIVERSITY**, Osaka (JP); **NATIONAL INSTITUTE OF INFORMATION AND COMMUNICATIONS TECHNOLOGY**, Tokyo (JP)

(21) Appl. No.: **15/800,613**

(22) Filed: **Nov. 1, 2017**

(30) **Foreign Application Priority Data**

Nov. 2, 2016 (JP) ..... 2016-215375

(57) **ABSTRACT**

An internal device of a brain-machine interface system includes: an electrode group including N electrodes, N being 2 or more; an amplification element group including N amplification elements; a communicator communicating with an external device; and a controller selectively executing one of: a normal operation mode in which electroencephalogram signals acquired through the N electrodes are supplied to the amplification element group in a manner that each of the N electrodes corresponds to a respective one of the N amplification elements, and N amplified electroencephalogram signals are transmitted; and a noise-reduction operation mode in which an electroencephalogram signal acquired through an M electrode of the electrode group is supplied to the amplification element group in a manner that each M electrode corresponds to respective plural ones of the amplification elements, and an M amplified electroencephalogram signal is transmitted, M being smaller than N.

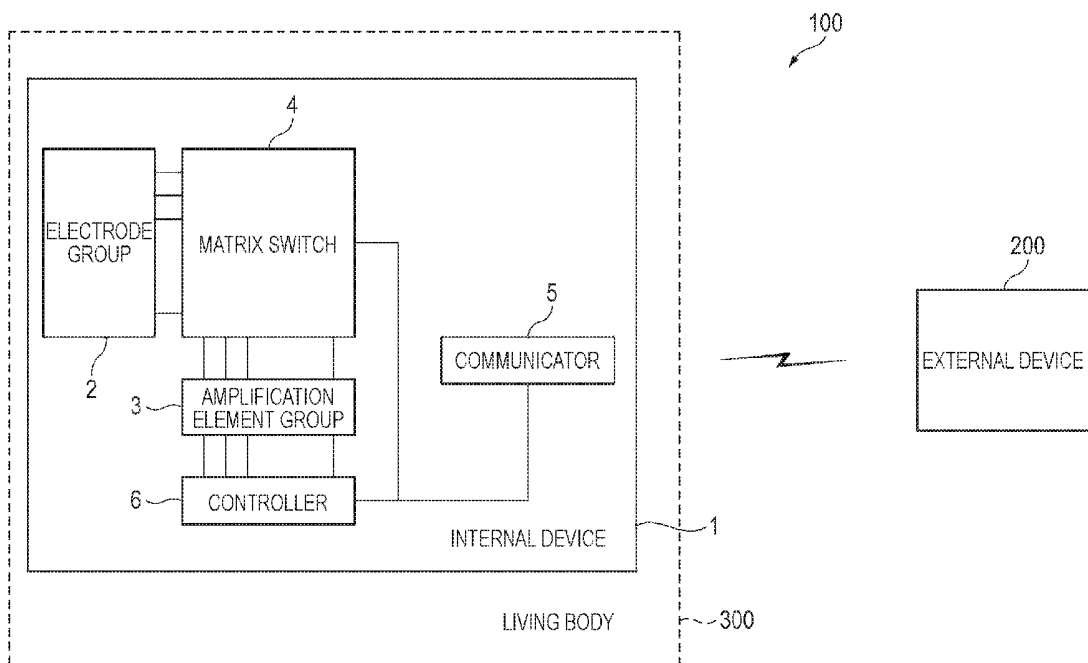

FIG. 1

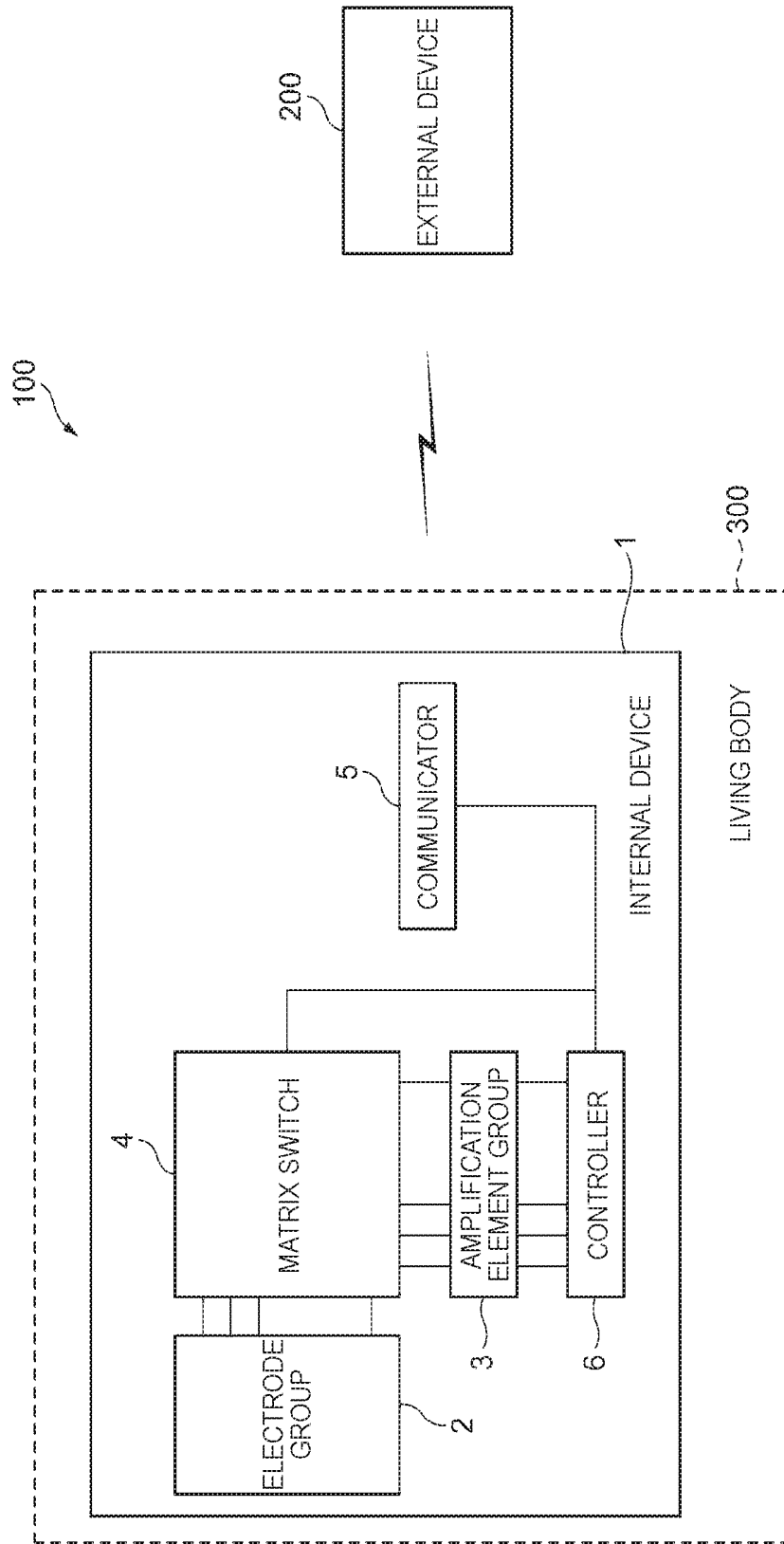
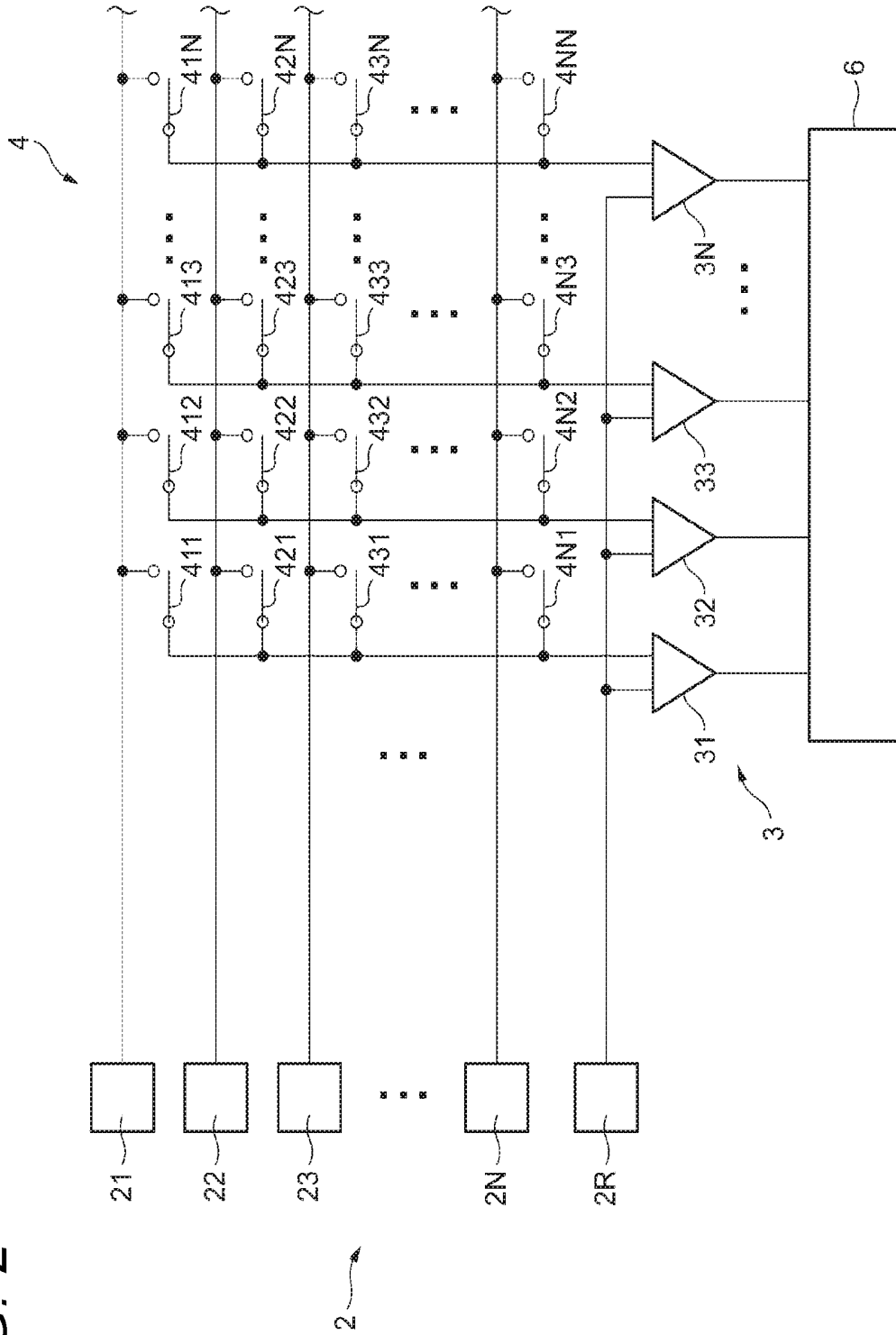

FIG. 2



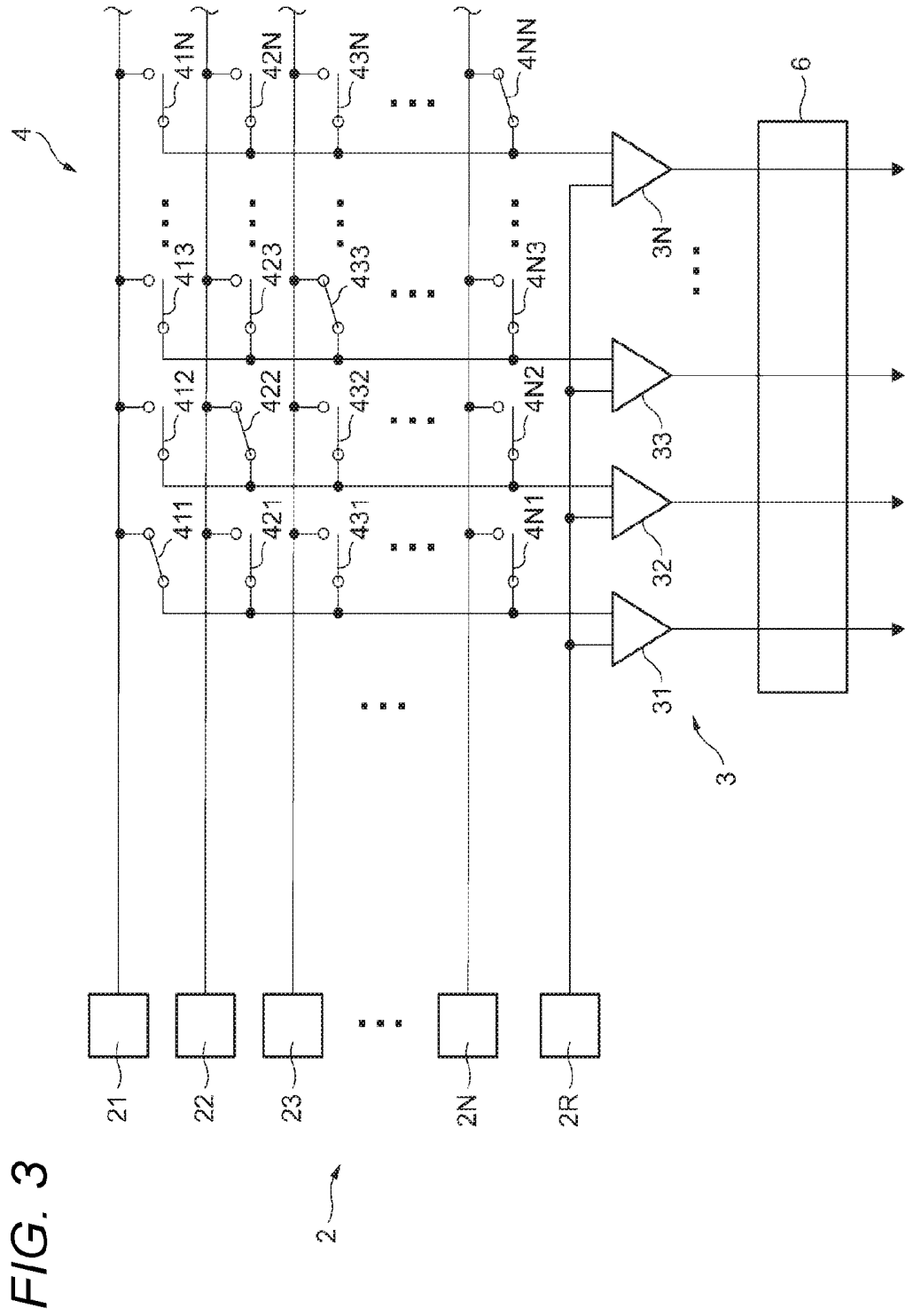

FIG. 3

FIG. 4

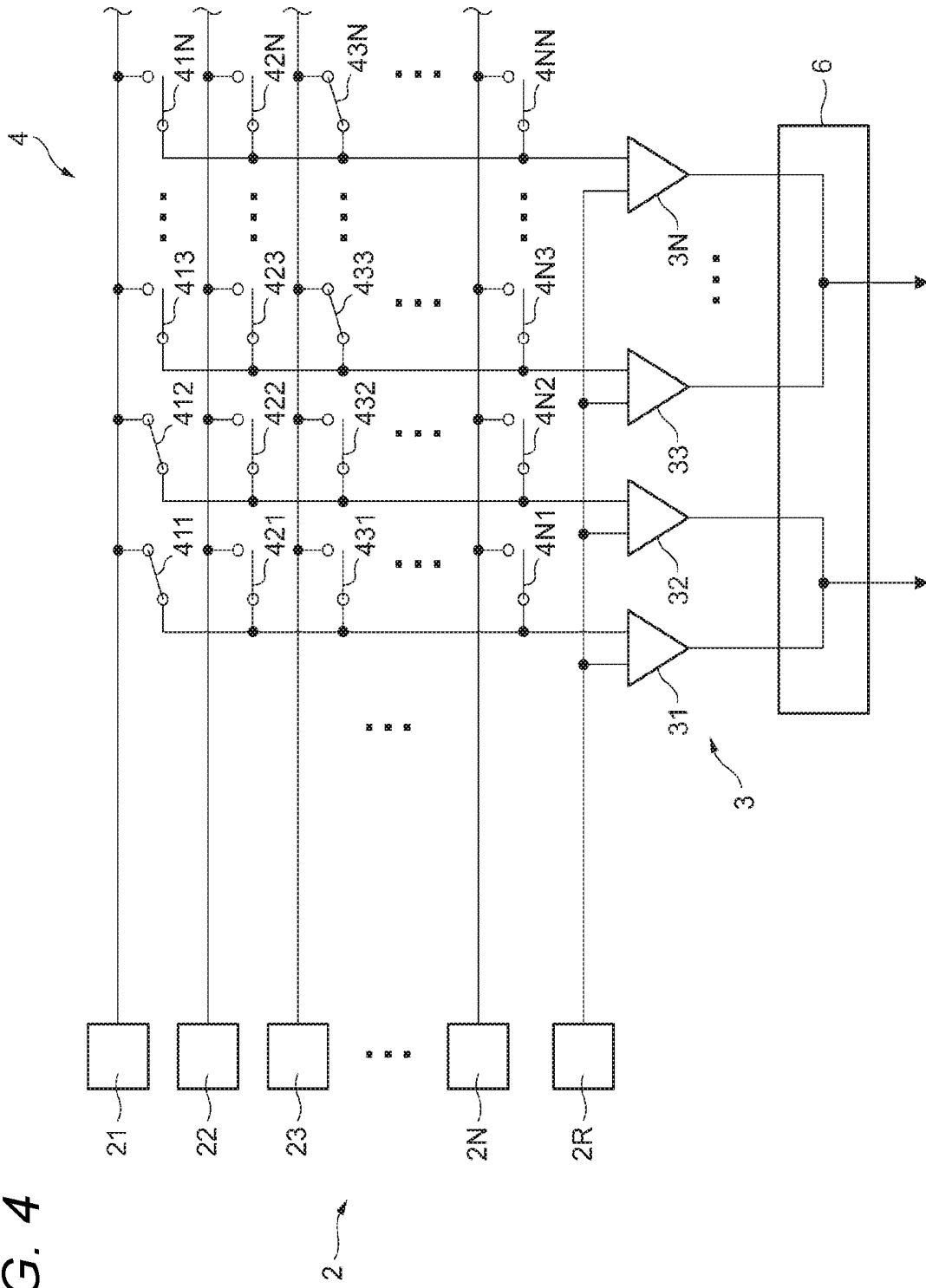

FIG. 5

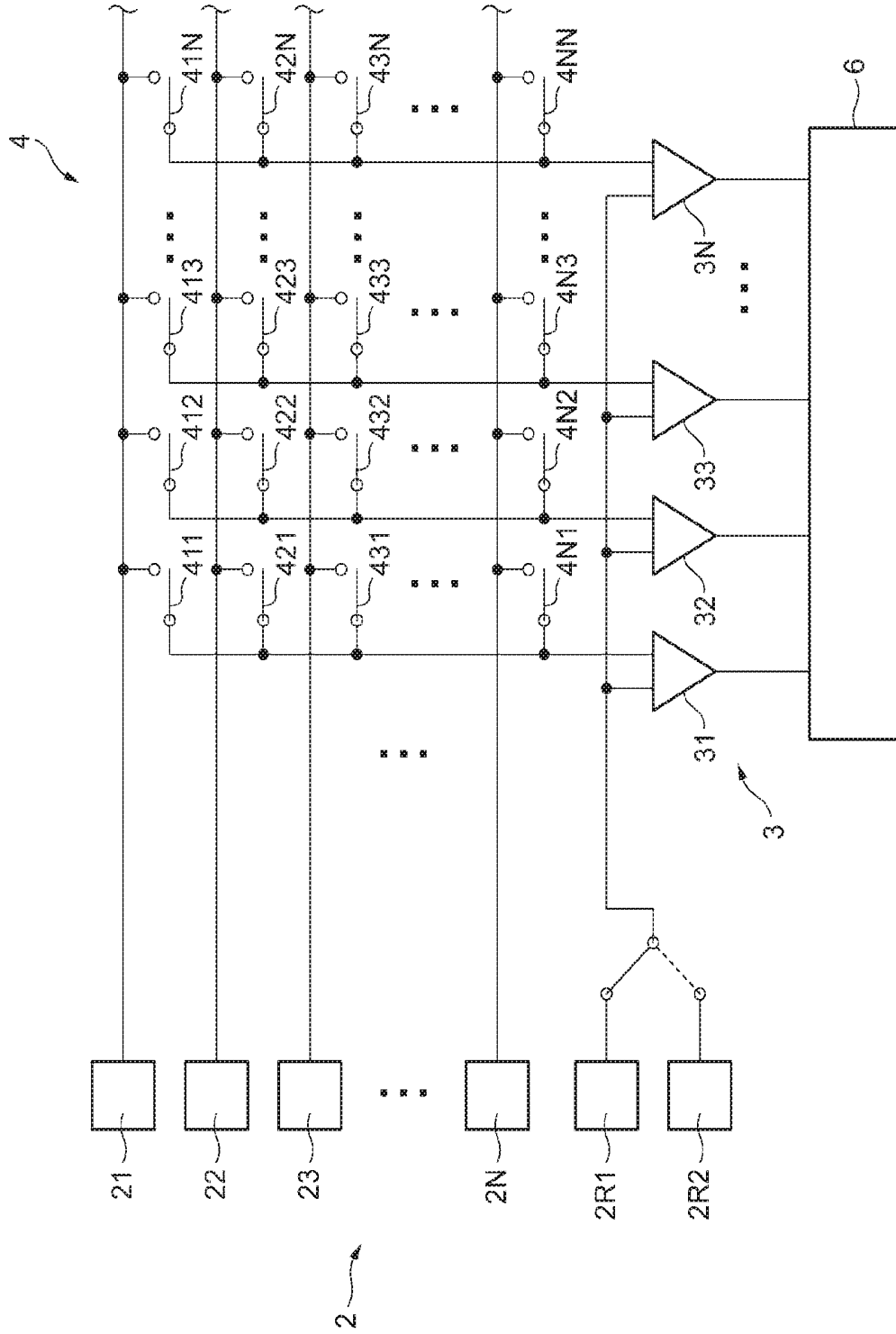

FIG. 6

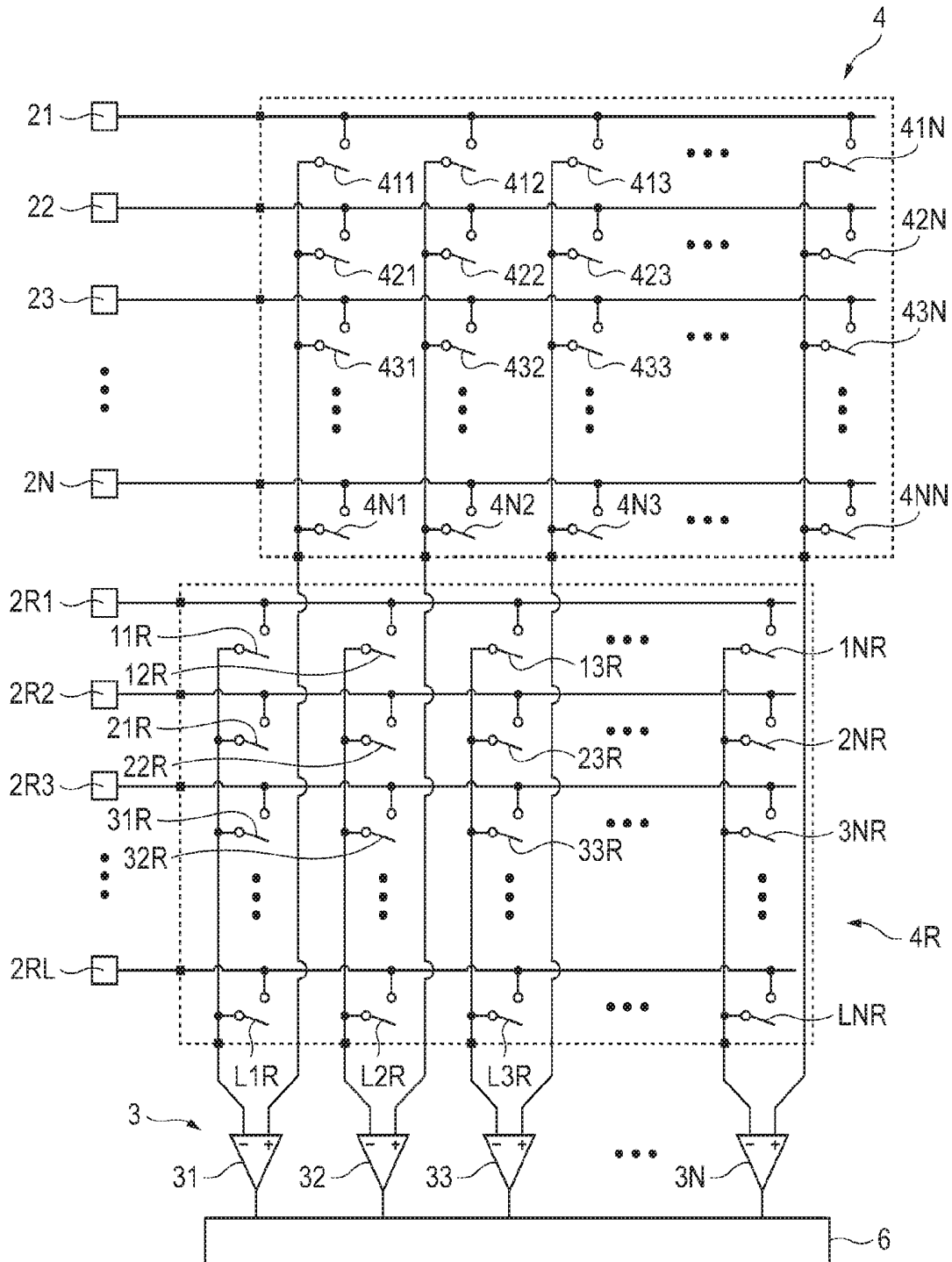

FIG. 7A

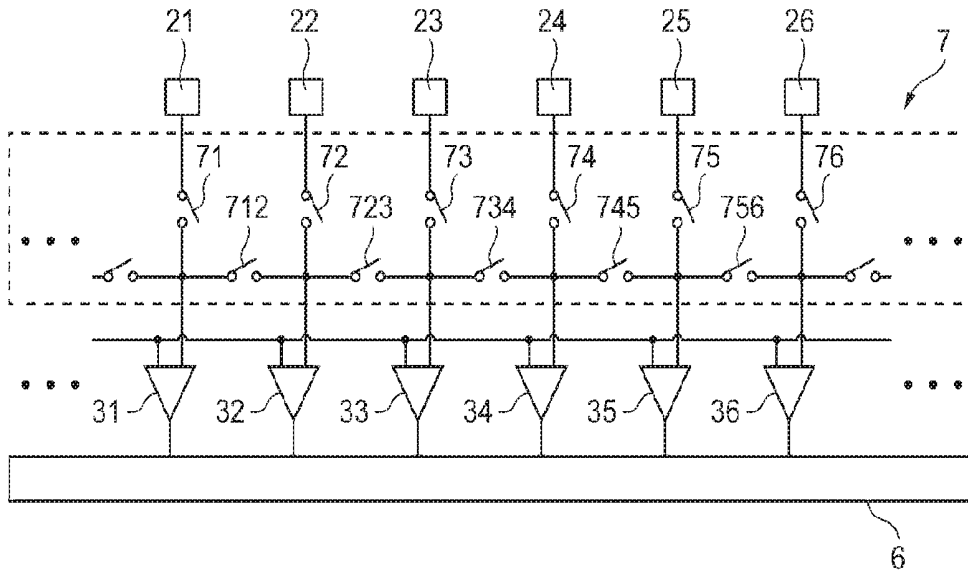
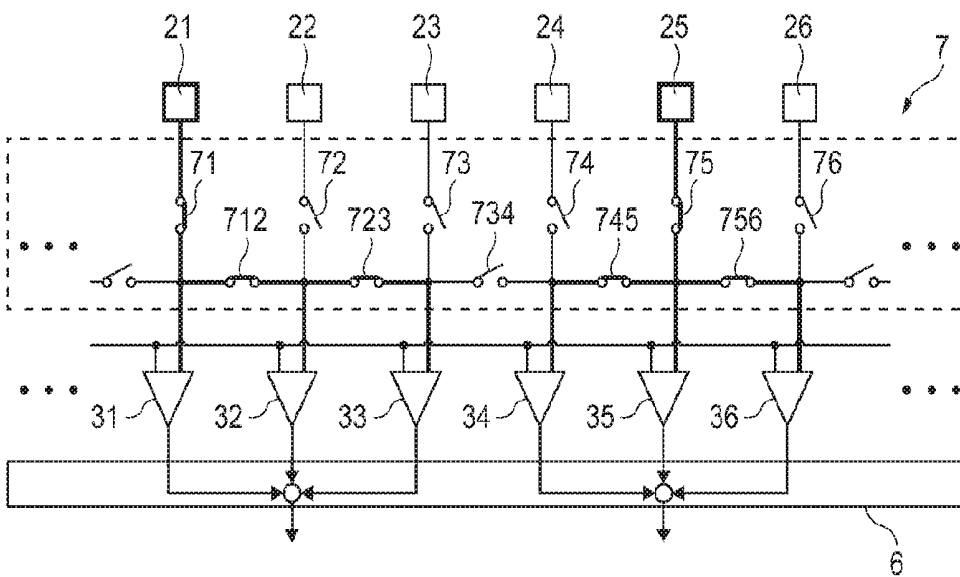

FIG. 7B



**INTERNAL DEVICE OF BRAIN-MACHINE  
INTERFACE SYSTEM INCLUDING NOISE  
REDUCTION TECHNIQUE, AND METHOD  
OF CONTROLLING THE INTERNAL  
DEVICE**

CROSS-REFERENCE TO RELATED  
APPLICATION(S)

[0001] This application is based upon and claims the benefit of priority from prior Japanese patent application No. 2016-215375, filed on Nov. 2, 2016, the entire contents of which are incorporated herein by reference.

BACKGROUND

[0002] The presently disclosed subject matter relates to a brain-machine interface (BMI) system including: an internal device which is to be implanted in the living body; and an external device which is to be placed outside the living body, particularly to the internal device and a method of controlling the internal device.

[0003] An internal device acquires brain waves functioning as a signal source to detect the brain activity, and transmits a signal which corresponds to the brain activity, or that which is obtained by processing the signal, to an external device. The external device operates in accordance with the signal received from the internal device. The internal device disclosed in US 2006/0049957 A1 includes a plurality of electrodes which are to be implanted in the living body to detect brain waves.

[0004] An internal device such as described above is implanted in the brain of a patient with amyotrophic lateral sclerosis (ALS) or the like, and communication with the patient is supported. In ALS, in the case of strong degeneration of upper motor neurons, however, brain waves gradually diminish. In order to adequately acquire diminished electroencephalogram signals, it is necessary to design the low-noise performance of a group of signal amplification elements which are mounted on the internal device, while anticipating the levels of the diminished electroencephalogram signals. When such a design is employed, however, the size increase of the internal device due to the scale enlargement of an amplification circuit, and heat generation due to the increase of power consumption are inevitable. Therefore, the design is not adequate for an implantable type internal device.

SUMMARY

[0005] The presently disclosed subject matter may provide an internal device of a brain-machine interface system and a method of controlling the internal device capable of performing the BMI control for a long period of time, even with respect to a patient in whom the intensity of brain waves is reduced with progression of disease.

[0006] The internal device of a brain-machine interface system, adapted to be implanted in a living body, may include: an electrode group which includes N electrodes acquiring electroencephalogram signals of the living body, wherein N is 2 or more; an amplification element group which includes N amplification elements; a communicator which is configured to wirelessly communicate with an external device; and a controller which is configured to control an electrical connection between the electrode group and the amplification element group, and which is config-

ured to control the communicator, the controller which is configured to selectively execute one of: a normal operation mode in which electroencephalogram signals of the living body that are acquired through the N electrodes of the electrode group are supplied to the amplification element group in a manner that each of the N electrodes corresponds to a respective one of the N amplification elements, and the communicator is caused to wirelessly transmit N amplified electroencephalogram signals; and a noise-reduction operation mode in which an electroencephalogram signal of the living body that is acquired through an M electrode of the electrode group is supplied to the amplification element group in a manner that each M electrode corresponds to respective plural ones of the amplification elements, and the communicator is caused to wirelessly transmit an M amplified electroencephalogram signal, wherein M is smaller than N.

BRIEF DESCRIPTION OF THE DRAWINGS

[0007] FIG. 1 is a block diagram showing the functional configuration of a BMI system which is an embodiment.

[0008] FIG. 2 is a circuit diagram showing a part of an internal device of the BMI system.

[0009] FIG. 3 is a circuit diagram illustrating the operation of the internal device.

[0010] FIG. 4 is a circuit diagram illustrating the operation of the internal device.

[0011] FIG. 5 is a circuit diagram showing a modification of the internal device.

[0012] FIG. 6 is a circuit diagram showing another modification of the internal device.

[0013] FIGS. 7A and 7B are circuit diagrams showing a further modification of the internal device.

DETAILED DESCRIPTION OF EXEMPLARY  
EMBODIMENTS

[0014] Hereinafter, an embodiment will be described in detail with reference to the accompanying drawings.

[0015] FIG. 1 shows the functional configuration of a BMI system 100 of an embodiment. The BMI system 100 includes an internal device 1 and an external device 200. The internal device 1 is configured so as to be used while being implanted in the living body 300 (specifically, the head). The external device 200 is configured so as to be used while being placed outside the living body 300.

[0016] The internal device 1 includes an electrode group 2 including N electrodes. In the following description, N is an integer of 2 or more. Each of the electrodes of the electrode group 2 is configured so as to be attached to a predetermined place of the brain of the living body 300, and acquire an electroencephalogram signal in the place.

[0017] The internal device 1 further includes: an amplification element group 3 including N amplification elements; and a matrix switch 4. The amplification element group 3 is electrically connected to the electrode group 2 through the matrix switch 4. Each of the amplification elements of the amplification element group 3 is configured so as to amplify an input signal, and output the amplified signal.

[0018] The internal device 1 further includes a communicator 5. The communicator 5 is electrically connected to output terminals of the amplification element group 3. The communicator 5 is configured so as to be able to wirelessly communicate with the external device 200.

[0019] The internal device 1 further includes a controller 6. The controller 6 is configured so as to operate the matrix switch 4 to control the electrical connection state between the electrode group 2 and the amplification element group 3. The controller 6 is also configured so as to be able to control the operation of the communicator 5.

[0020] FIG. 2 specifically shows the circuit configuration of a part of the internal device 1. The electrode group 2 includes N electrodes 21, 22, 23, . . . , 2N. The amplification element group 3 includes N amplification elements 31, 32, 33, . . . , 3N.

[0021] The matrix switch 4 includes an N×N number of switch elements. Each of the switch elements is electrically connected to the controller 6 through a signal line which is not shown. Therefore, the controller 6 can control the opening/closing operation of each of the switch elements.

[0022] The matrix switch includes switch elements 411, 412, 413, . . . , 41N. The input ends of the switch elements 411, 412, 413, . . . , 41N are electrically connected to the electrode 21.

[0023] The matrix switch further includes switch elements 421, 422, 423, . . . , 42N. The input ends of the switch elements 421, 422, 423, . . . , 42N are electrically connected to the electrode 22.

[0024] The matrix switch further includes switch elements 431, 432, 433, . . . , 43N. The input ends of the switch elements 431, 432, 433, . . . , 43N are electrically connected to the electrode 23.

[0025] The matrix switch further includes switch elements 4N1, 4N2, 4N3, . . . , 4NN. The input ends of the switch elements 4N1, 4N2, 4N3, . . . , 4NN are electrically connected to the electrode 2N.

[0026] The output ends of the switch elements 411, 421, 431, . . . , 4N1 are electrically output to the amplification element 31. When the switch element 4N1 is closed, for example, the electroencephalogram signal which is acquired by the electrode 2N is supplied to the amplification element 31.

[0027] The output ends of the switch elements 412, 422, 432, . . . , 4N2 are electrically output to the amplification element 32. When the switch element 432 is closed, for example, the electroencephalogram signal which is acquired by the electrode 23 is supplied to the amplification element 32.

[0028] The output ends of the switch elements 413, 423, 433, . . . , 4N3 are electrically output to the amplification element 33. When the switch element 423 is closed, for example, the electroencephalogram signal which is acquired by the electrode 22 is supplied to the amplification element 33.

[0029] The output ends of the switch elements 41N, 42N, 43N, . . . , 4NN are electrically output to the amplification element 3N. When the switch element 41N is closed, for example, the electroencephalogram signal which is acquired by the electrode 21 is supplied to the amplification element 3N.

[0030] The electrode group 2 further includes an electrode 2R. The electroencephalogram signal which is acquired through the electrode 2R is supplied as a reference potential signal to the amplification elements 31, 32, 33, . . . , 3N, respectively. Namely, the electrode 2R is used as the reference potential supply source.

[0031] Each of the amplification elements 31, 32, 33, . . . , 3N is configured so as to amplify the difference between the

input electroencephalogram signal and the reference potential signal, by a predetermined amplification factor, and output the amplified signal. The amplified electroencephalogram signals which are output respectively from the amplification elements 31, 32, 33, . . . , 3N are supplied to the controller 6.

[0032] The controller 6 is configured so as to selectively execute one of a normal operation mode and a noise-reduction operation mode. FIG. 3 shows a configuration example of the matrix switch 4 during execution of the normal operation mode, and FIG. 4 shows a configuration example of the matrix switch 4 during execution of the noise-reduction operation mode.

[0033] When the normal operation mode is executed, the controller 6 causes the electroencephalogram signals of the living body 300 which are acquired through the N electrodes of the electrode group 2, to the N amplification elements of the amplification element group 3, in such a manner that each of the electrodes corresponds to a respective one of the amplification elements.

[0034] As shown in FIG. 3, for example, the controller 6 controls the matrix switch 4 so that the switch elements 411, 422, 433, . . . , 4NN are closed. Therefore, the electroencephalogram signal acquired through the electrode 21 is supplied to the amplification element 31. Similarly, the electroencephalogram signal acquired through the electrode 22 is supplied to the amplification element 32, that acquired through the electrode 23 is supplied to the amplification element 33, and that acquired through the electrode 2N is supplied to the amplification element 3N.

[0035] As a result, the N amplified electroencephalogram signals which are output from the amplification elements 31, 32, 33, . . . , 3N are supplied to the controller 6. The controller 6 relays directly the N amplified electroencephalogram signals which are input thereto, to the communicator 5. Thereafter, the controller 6 causes the communicator 5 to wirelessly transmit the N amplified electroencephalogram signals at a predetermined timing. The amplified electroencephalogram signals which are wirelessly transmitted are received by the external device 200. The external device 200 operates in accordance with the received and amplified electroencephalogram signals.

[0036] The external device 200 may be identical with or different from a device which receives the signals transmitted from the internal device 1, and which executes an operation based on the signals. For example, the external device 200 may be a device which receives the signals transmitted from the internal device 1, and which transmits a control signal that causes another external device to execute the operation based on the transmitted signals.

[0037] When the noise-reduction operation mode is executed, the controller 6 causes the electroencephalogram signals of the living body 300 which are acquired through an M number of electrodes (M is smaller than N) of the electrode group 2, to be supplied to the amplification element group 3 in such a manner that each electrode corresponds to respective plural ones of the amplification elements.

[0038] As shown in FIG. 4, for example, the controller 6 controls the matrix switch 4 so that the switch elements 411, 412, 433, . . . , 43N are closed. Therefore, the electroencephalogram signal acquired through the electrode 21 is supplied in parallel to the amplification elements 31, 32. Similarly, the electroencephalogram signal acquired through

the electrode **23** is supplied in parallel to the amplification element group including the amplification elements **33**, **3N**. In this example, namely,  $M$  is 2.

[0039] Next, the controller **6** performs a process of arithmetically averaging the amplified electroencephalogram signals which are output from the plurality of amplification elements that correspond to each of the  $M$  electrodes. In this example, the amplified electroencephalogram signals which are output from the amplification elements **31**, **32** that correspond to the electrode **21** are arithmetically averaged. Similarly, the amplified electroencephalogram signals which are output from the amplification elements **33**, **3N** that correspond to the electrode **23** are arithmetically averaged. As a result, the controller **6** acquires  $M$  (in the example,  $M$  is 2) arithmetically averaged and amplified electroencephalogram signals.

[0040] It is known that, when a signal with noises is supplied to  $n$  amplification elements, and the  $n$  amplified signals which are output from the  $n$  amplification elements are arithmetically averaged, the noise level of the obtained signal is reduced to  $1/\sqrt{n}$  as compared to that of the signal which has not been arithmetically averaged. In this example, therefore, the noise level can be reduced to  $1/\sqrt{2}$  by arithmetically averaging the amplified electroencephalogram signals which are output from the amplification elements **31**, **32**. In the case where  $m$  amplification elements are included in the amplification element group that includes the amplification elements **33**, **3N**, similarly, the noise level can be reduced to  $1/\sqrt{m}$  by arithmetically averaging amplified electroencephalogram signals output from the amplification element group.

[0041] The controller **6** relays the  $M$  amplified electroencephalogram signals in which the noise level is reduced, to the communicator **5**. Thereafter, the controller **6** causes the communicator **5** to wirelessly transmit the  $M$  amplified electroencephalogram signals at a predetermined timing. The amplified electroencephalogram signals which are wirelessly transmitted are received by the external device **200**. The external device **200** operates in accordance with the received and amplified electroencephalogram signals.

[0042] Next, a method of operating the thus configured internal device **1** will be described. It is assumed that the living body **300** is a patient in whom brain waves diminish with progression of disease. An example of disease is ALS. The internal device **1** is implanted in the head of the patient in a stage where communication with the patient can be well performed.

[0043] The controller **6** first executes the normal operation mode. In the normal operation mode, electroencephalogram signals of the patient are acquired by using the electrode group **2** including as many ( $N$ ) electrodes as possible, and therefore also the number of channels for the amplified electroencephalogram signals which are supplied to the external device **200** through the communicator **5** is maximum. Consequently, a rapid BMI control having a high degree of freedom can be performed.

[0044] With progression of disease, the brain waves of the patient diminish, and the SN ratios of the acquired electroencephalogram signals are lowered. When it is determined that it is difficult to perform a significant BMI control based on the brain waves which are acquired in the normal operation mode, the controller **6** executes the noise-reduction operation mode.

[0045] Specifically,  $M$  electrodes which are to continue to acquire electroencephalogram signals are selected from the  $N$  electrodes of the electrode group **2**. Through observation of the BMI control performed in the normal operation mode, the  $M$  electrodes are selected as an electrode group with higher priority to perform a significant BMI control. The selected  $M$  electrodes may be varied depending on the patient. A signal designating the selected  $M$  electrodes is wirelessly transmitted from the external device **200**, and then received by the communicator **5**. Based on the signal received by the communicator **5**, the controller **6** operates the matrix switch **4**.

[0046] Each of  $M$  electroencephalogram signals in which the SN ratio is lowered is supplied to a plurality of amplification elements. The amplified electroencephalogram signals which are output from the plurality of amplification elements are arithmetically averaged. As a result,  $M$  amplified electroencephalogram signals in which the noise level is lowered as compared with the case of the normal operation mode are obtained. The number of used electrodes, i.e., the channel number is reduced, and therefore it is unavoidable that the degree of freedom of the BMI control is lowered. In brain waves of the patient, however, small changes, which, in the related art, are buried in noise can be distinguished. Even with respect to a patient in whom the intensity of brain waves is reduced with progression of disease, therefore, the possibility of the BMI control can be provided for a long period of time.

[0047] In the embodiment, the function of the controller **6** is realized from software executed by a cooperation of a processor and memory which are communicably connected to each other. Examples of the processor are a CPU and an MPU. Examples of the memory are a RAM and a ROM. However, the function of the controller **6** may be realized by hardware such as an ASIC or an FPGA, or a combination of hardware and software.

[0048] The above-described embodiment is a mere example for facilitating understanding of the presently disclosed subject matter. The configuration of the embodiment may be adequately changed or improved without departing the spirit of the presently disclosed subject matter. It is obvious that equivalents are included within the technical scope of the presently disclosed subject matter.

[0049] In the above-described embodiment, the electroencephalogram signal acquired by the electrode **2R** is supplied as the reference potential signal to each of the amplification elements of the amplification element group **3**. Alternatively, a configuration may be employed in which, as shown in FIG. **5**, one of two electrodes **2R1**, **2R2** (an example of the plurality of reference potential supply sources) is electrically connected to the amplification element group **3** in a switchable manner. The number of switchable electrodes may be 3 or more.

[0050] The internal device **1** is used while being implanted in the living body **300**, and therefore cannot be easily taken out from the body after the operation is started. According to the configuration, even when any failure occurs in the electrode **2R1** which is originally used as the reference potential supply source, the reference potential supply source can be switched to the other electrode **2R2**, so that the amplification element group **3** can continue to operate. Therefore, the number of opportunities of exchanging the internal device **1** which impose a burden on the patient can

be reduced, and the possibility of the BMI control can be provided for a long period of time.

**[0051]** A configuration may be employed that, as shown in FIG. 6, includes a matrix switch 4R in which the above-described function of switching between the electrodes 2R1, 2R2 is more generalized. The matrix switch 4R includes  $L \times N$  switch elements (11R, 12R, . . . , LNR). Here, L is an integer of N or less. The electrode group 2 includes L electrodes 2R1, 2R2, 2R3, . . . , 2RL.

**[0052]** When all switch elements in which the input end is connected to one of the electrodes 2R1 to 2RL (for example, the switch elements 31R to 3NR connected to the electrode 2R3) are closed, the potential which is supplied through the electrode 2R3 is supplied as the reference potential or a differential input to the amplification elements 31 to 3N.

**[0053]** When switch elements which are arbitrarily selected from the switch elements 411 to 4NN included in the matrix switch 4, and the switch elements 11R to LNR included in the matrix switch 4R are closed, alternatively, the electroencephalogram signal acquired by one of the electrodes 21 to 2N, and the reference potential or differential input acquired by one of the electrodes 2R1 to 2RL can be supplied to any one of the amplification elements 31 to 3N.

**[0054]** A switch signal is wirelessly transmitted from the external device 200, and then received by the communicator 5. Based on the received signal, the switching of the reference potential supply sources can be performed by the controller 6. Alternatively, a configuration may be employed in which the controller 6 detects a failure of the original reference potential supply source, and then automatically performs switching of the reference potential supply sources.

**[0055]** In place of the matrix switch 4 in the above-described embodiment, the internal device 1 may include a ladder-type switch circuit network 7 shown in FIG. 7A. In the example, the electrodes 21 to 26 are shown as a part of the electrode group 2, the amplification elements 31 to 36 are shown as a part of the amplification element group 3, and switch elements 71 to 76 and 712 to 756 are shown as a part of the ladder-type switch circuit network 7.

**[0056]** The input end of the switch element 71 is connected to the electrode 21. The output end of the switch element 71 is connected to the amplification element 31. The switch element 712 can connect the output ends of the adjacent switch elements 71, 72 together. Assuming that  $n$  is an arbitrary integer, similarly, the input end of a switch element  $7n$  is connected to an electrode  $2n$ , and the output end of the switch element  $7n$  is connected to an amplification element  $3n$ . Moreover, a switch element  $7n(n+1)$  connects the output end of the switch element  $7n$  to that of a switch element  $7(n+1)$ .

**[0057]** FIG. 7B shows an example of the operation of the thus configured ladder-type switch circuit network 7. When the switch elements 71, 712, 723 are closed, the electroencephalogram signal acquired by the electrode 21 is supplied to the amplification elements 31, 32, 33. When the switch elements 75, 745, 756 are closed, similarly, the electroencephalogram signal acquired by the electrode 25 is supplied to the amplification elements 34, 35, 36.

**[0058]** In the above-described embodiment, the selection of either of the normal operation mode and the noise-reduction operation mode is performed by the controller 6 based on the signal which is received from the external

device 200 by the communicator 5. However, the internal device 1 can be configured so as to detect the noise levels of the electroencephalogram signals acquired by the electrode group 2. In this case, based on the detected noise levels, the controller 6 determines whether a significant BMI control can be performed in the normal operation mode or not. If it is determined that a significant BMI control cannot be performed in the normal operation mode, the controller 6 automatically selects the noise-reduction operation mode.

**[0059]** According to an aspect of the presently disclosed subject matter, in the normal operation mode, electroencephalogram signals of the patient are acquired by using as many (the N number of) electrodes as possible. Therefore, also the number of channels for the amplified electroencephalogram signals which are supplied to the external device through the communicator is maximum. Consequently, a rapid BMI control having a high degree of freedom can be performed.

**[0060]** In the case of a patient in whom brain waves diminish with progression of disease, the SN ratio of an acquired electroencephalogram signal is lowered with the progression of the disease. Upon a timing when it is difficult to perform a significant BMI control based on electroencephalogram signals which are acquired in the normal operation mode, the controller can execute the noise-reduction operation mode. At this time, the M number of electrodes are selected from the N electrodes.

**[0061]** In the noise-reduction operation mode, each of the M electroencephalogram signals in which the SN ratio is lowered is supplied to a plurality of amplification elements. As a result, M amplified electroencephalogram signals in which the noise level is lowered as compared with the case of the normal operation mode are obtained. The number of used electrodes, i.e., the channel number is reduced, and therefore it is unavoidable that the degree of freedom of the BMI control is lowered. In brain waves of the patient, however, small changes, which, in the related art, are buried in noise can be distinguished. Even with respect to a patient in whom the intensity of brain waves is reduced with progression of disease, therefore, the possibility of the BMI control can be provided for a long period of time.

What is claimed is:

1. An internal device of a brain-machine interface system, the internal device adapted to be implanted in a living body, the internal device comprising:

an electrode group which includes N electrodes acquiring electroencephalogram signals of the living body, wherein N is 2 or more;

an amplification element group which includes N amplification elements;

a communicator which is configured to wirelessly communicate with an external device; and

a controller which is configured to control an electrical connection between the electrode group and the amplification element group, and which is configured to control the communicator, the controller which is configured to selectively execute one of:

a normal operation mode in which electroencephalogram signals of the living body that are acquired through the N electrodes of the electrode group are supplied to the amplification element group in a manner that each of the N electrodes corresponds to a respective one of the N amplification elements, and

- the communicator is caused to wirelessly transmit N amplified electroencephalogram signals; and
- a noise-reduction operation mode in which an electroencephalogram signal of the living body that is acquired through an M electrode of the electrode group is supplied to the amplification element group in a manner that each M electrode corresponds to respective plural ones of the amplification elements, and the communicator is caused to wirelessly transmit an M amplified electroencephalogram signal, wherein M is smaller than N.
2. The internal device according to claim 1, wherein the controller is configured to arithmetically average outputs of the amplification elements to acquire the M amplified electroencephalogram signal.
  3. The internal device according to claim 1, further comprising: a plurality of reference potential supply sources, wherein
    - the controller is configured to cause one of the reference potential supply sources to be electrically connected to the amplification element group in a switchable manner.
  4. The internal device according to claim 1, wherein, based on a signal which is received from the external device by the communicator, the controller is configured to execute selection of one of the normal operation mode and the noise-reduction operation mode.
  5. The internal device according to claim 1, wherein, based on noise levels of the acquired electroencephalogram signals, the controller is configured to automatically execute selection of one of the normal operation mode and the noise-reduction operation mode.
  6. A method of controlling an internal device of a brain-machine interface system, the internal device adapted to be implanted in a living body, the method comprising:
    - by a controller of the internal device, selectively executing one of:
      - a normal operation mode in which electroencephalogram signals of the living body that are acquired through N electrodes of an electrode group are supplied to an amplification element group in a manner that each of the N electrodes corresponds to a respective one of N amplification elements of the amplification element group, and N amplified electroencephalogram signals are output, wherein N is 2 or more; and
      - a noise-reduction operation mode in which an electroencephalogram signal of the living body that is acquired through an M electrode of the electrode group is supplied to the amplification element group in a manner that each M electrode corresponds to respective plural ones of the amplification elements of the amplification element group, and an M amplified electroencephalogram signal is output, wherein M is smaller than N.
    7. The method according to claim 6, wherein outputs of the amplification elements are arithmetically averaged by the controller to acquire the M amplified electroencephalogram signal.
    8. The method according to claim 6, further comprising: by the controller, electrically connecting one of a plurality of reference potential supply sources to the amplification element group in a switchable manner.
    9. The method according to claim 6, wherein the selection of one of the normal operation mode and the noise-reduction operation mode is executed by the controller based on a signal which is wirelessly transmitted from an external device.
    10. The method according to claim 6, wherein the selection of one of the normal operation mode and the noise-reduction operation mode is executed by the controller based on noise levels of the acquired electroencephalogram signals.

\* \* \* \* \*

专利名称(译)	包括降噪技术的脑机接口系统的内部装置，以及控制内部装置的方法		
公开(公告)号	<a href="#">US20180120937A1</a>	公开(公告)日	2018-05-03
申请号	US15/800613	申请日	2017-11-01
[标]申请(专利权)人(译)	日本光电工业株式会社 国立大学法人大阪大学 独立行政法人情报通信研究机构		
申请(专利权)人(译)	日本光电公司 大阪大学 国立信息和通信技术		
当前申请(专利权)人(译)	日本光电公司 大阪大学 国家信息与通信技术研究所		
[标]发明人	IMAJO KAORU SUZUKI KATSUYOSHI HIRATA MASAYUKI KAMEDA SEIJI SUZUKI TAKAFUMI ANDO HIROSHI		
发明人	IMAJO, KAORU SUZUKI, KATSUYOSHI HIRATA, MASAYUKI KAMEDA, SEIJI SUZUKI, TAKAFUMI ANDO, HIROSHI		
IPC分类号	G06F3/01 A61B5/0478 A61B5/00 A61B5/04		
CPC分类号	G06F3/015 A61B5/0478 A61B5/0006 A61B5/7203 A61B5/04012 A61B5/6868 A61B2562/0209 A61B5/04004 A61B5/0476		
优先权	2016215375 2016-11-02 JP		
其他公开文献	US10620702		
外部链接	<a href="#">Espacenet</a> <a href="#">USPTO</a>		

#### 摘要(译)

一种脑机接口系统的内部装置包括：包括N个电极的电极组，N为2或更大；包括N个放大元件的放大元件组；与外部设备通信的通信器；以及控制器，选择性地执行下述之一：正常操作模式，其中以N个电极中的每一个对应于N个放大元件中的相应一个的方式将通过N个电极获取的脑电信号提供给放大元件组，以及N放大的脑电波信号被发送；以及降噪运转模式，其中通过电极组的M电极获取的脑电波信号以每个M电极对应于多个放大元件中的相应多个放大元件的方式被提供给放大元件组，并且M放大的脑电图信号被发送，M小于N。

