



US 20170020420A1

(19) **United States**

(12) **Patent Application Publication**

**Shin et al.**

(10) **Pub. No.: US 2017/0020420 A1**

(43) **Pub. Date: Jan. 26, 2017**

(54) **METHOD, APPARATUS AND NON-TRANSITORY COMPUTER-READABLE RECORDING MEDIUM FOR MEASURING PHOTOPLETHYSMOGRAPHY SIGNALS**

**Publication Classification**

(51) **Int. Cl.**  
*A61B 5/1455* (2006.01)  
*A61B 5/00* (2006.01)

(52) **U.S. Cl.**  
 CPC ..... *A61B 5/14552* (2013.01); *A61B 5/7278* (2013.01); *A61B 5/7203* (2013.01); *A61B 5/7221* (2013.01); *A61B 2562/0238* (2013.01)

(71) Applicant: **HUINNO CO., LTD.**, Seoul (KR)

(72) Inventors: **Min-Yong Shin**, Suwon (KR); **Yoon Chul Choi**, Seongnam (KR); **Jin Hong Jeon**, Suwon (KR); **Jee Young Song**, Seoul (KR); **Seong Jun Shin**, Seongnam (KR)

(73) Assignee: **HUINNO CO., LTD.**

(21) Appl. No.: **15/215,127**

(22) Filed: **Jul. 20, 2016**

(30) **Foreign Application Priority Data**

Jul. 20, 2015 (KR) ..... 10-2015-0102695  
 Feb. 26, 2016 (KR) ..... 10-2016-0023632

(57) **ABSTRACT**

Provided herein are methods, apparatuses, and non-transitory computer-readable recording media for measuring photoplethysmography (PPG) signals. Accurate PPG signals can be obtained even in a situation in which brightness of ambient light is not constant due to external light sources, and accuracy of a variety of biological information derivable from the PPG signals can be improved.

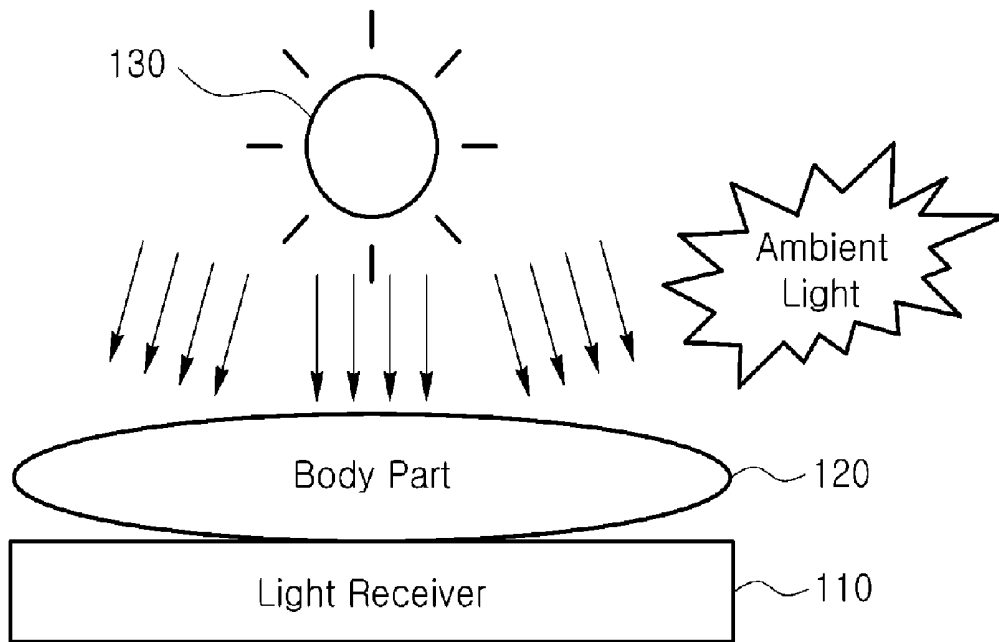

FIG. 1

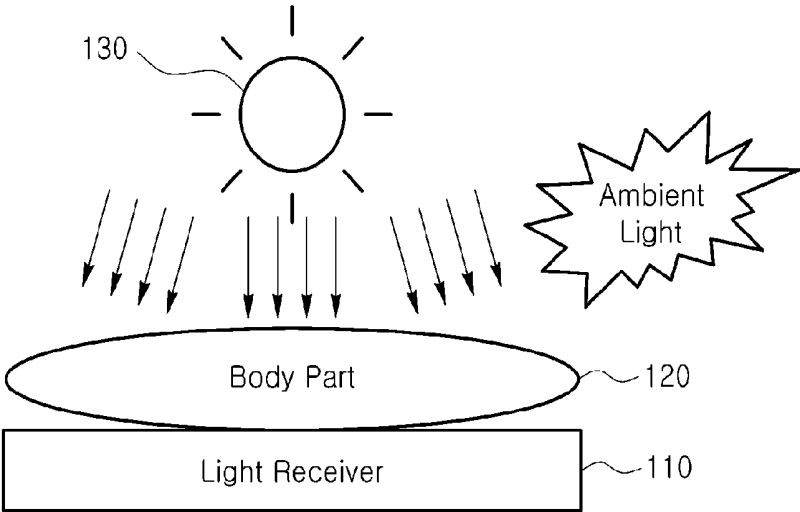
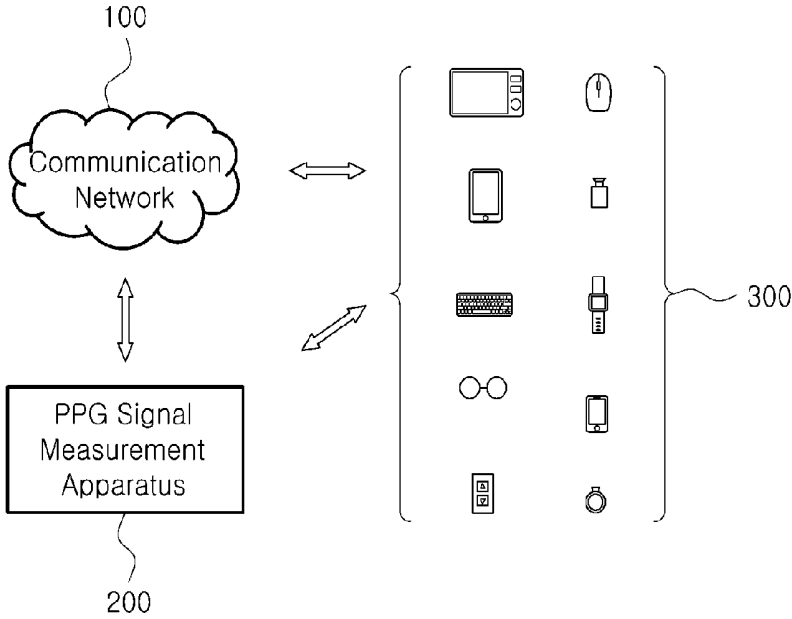
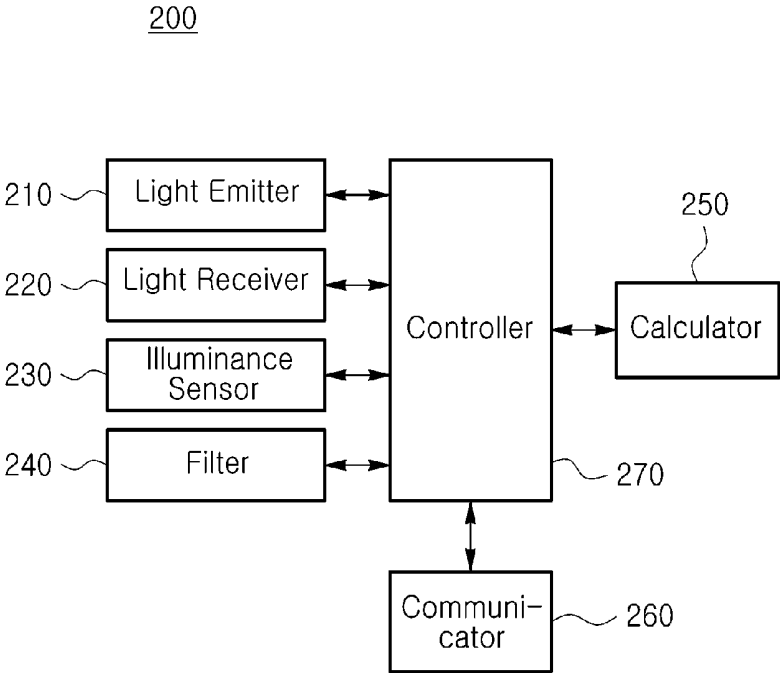

FIG. 2



**FIG. 3**



**FIG. 4**

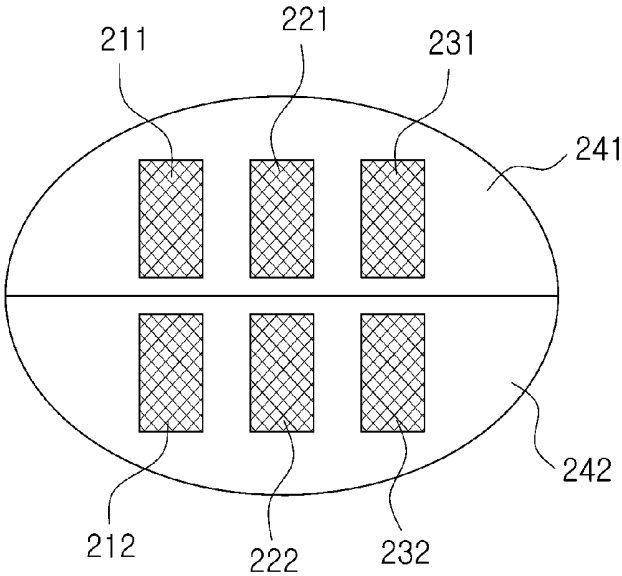
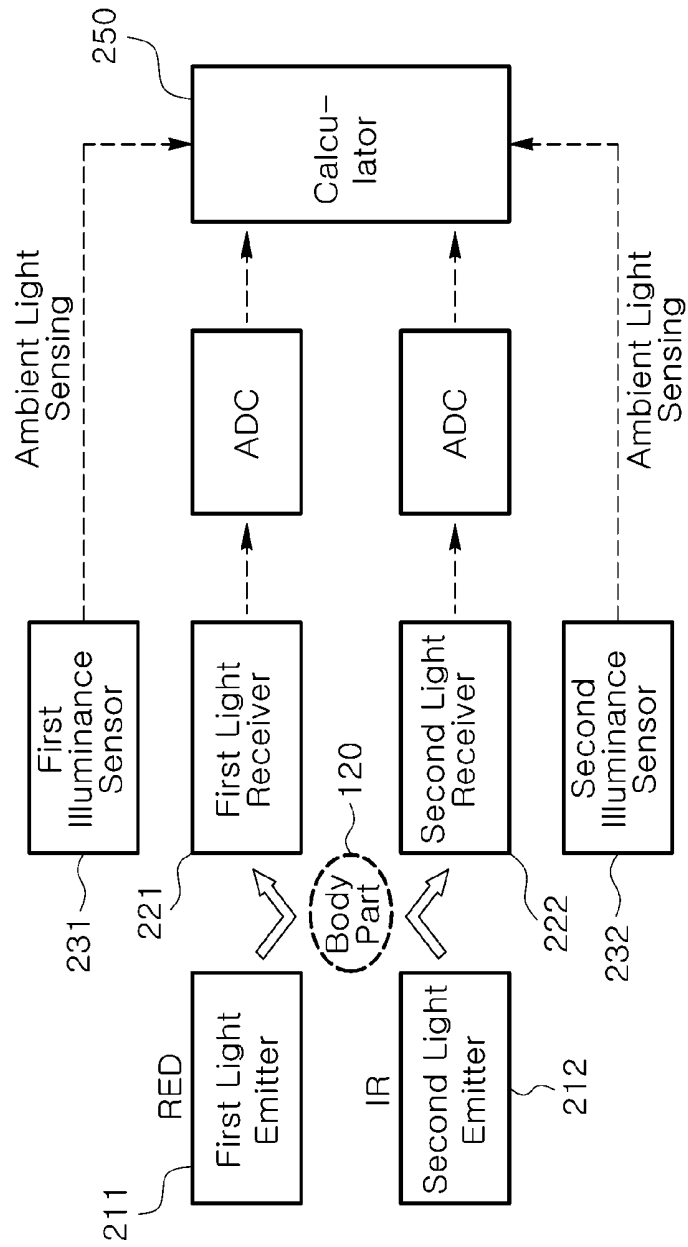

FIG. 5



**METHOD, APPARATUS AND  
NON-TRANSITORY COMPUTER-READABLE  
RECORDING MEDIUM FOR MEASURING  
PHOTOPLETHYSMOGRAPHY SIGNALS**

**CROSS-REFERENCE TO RELATED  
APPLICATIONS**

[0001] This application claims priority to Korean Application No. 10-2015-0102695, filed Jul. 20, 2015, and Korean Application No. 10-2016-0023632, filed Feb. 26, 2016. The applications are incorporated herein by reference.

**FIELD OF THE INVENTION**

[0002] The present invention relates to methods, apparatuses and non-transitory computer-readable recording media for measuring photoplethysmography signals.

**BACKGROUND**

[0003] Due to recent rapid progress in science and technology, the quality of life of all mankind is being enhanced and medical environment has changed a great deal. In the past, once a medical image was taken by means such as X-ray, CT, fMRI or the like, it would take several hours or days to be able to interpret the image.

[0004] However, a picture archive communication system (PACS) has been introduced to enable a medical image to be taken and then transmitted to a monitor screen of a radiology specialist for prompt interpretation. Further, medical equipment for ubiquitous healthcare are wide spread so that patient-performed self-checks on blood glucose and blood pressure are feasible at anytime and anywhere out of hospital, and diabetic or hypertensive patients use the equipment at their home and/or office. Particularly, in the case of hypertension, which is one of the principal causes of various diseases and whose prevalence rate is increasing, there is a need for a system for consistent measurement and real-time notification of blood pressure, and various types of studies associated therewith are being attempted.

[0005] Meanwhile, biological information such as an electrocardiogram, heart rate, body temperature, oxygen saturation level, electromyogram, sweat gland activity, sweat rate, and respiratory rate is obtained on the basis of biosignals respectively acquired from two or more contacts on a human body (not necessarily adjoining each other physically), and thus a technique for properly processing and measuring the biosignals acquired from the contacts on the body is required to obtain biological information.

[0006] Photoplethysmography (PPG) signals are significantly utilized in measuring a variety of biological information on cardiac functions, including blood oxygen saturation levels ( $SpO_2$ ). According to conventional PPG signal measurement techniques that have been used so far, there are technical constraints such as a need for a shielding structure for preventing errors caused by external light sources.

[0007] As a technique for measuring a blood oxygen saturation level ( $SpO_2$ ) using PPG signals, it is possible to sense visible light (e.g., red light, green light, etc.) and infrared light reflected from a human body and calculate an oxygen saturation level on the basis of PPG signals, each corresponding to the sensed visible light and infrared light. The technique is based on a principle that light absorptivity of oxyhemoglobin ( $HbO_2$ ) in blood is greater for infrared light than for visible light.

[0008] FIG. 1 illustrates a situation in which an oxygen saturation level is measured according to the prior art. Referring to FIG. 1, a light receiver 110 of a conventional PPG signal measurement apparatus receives not only light irradiated onto a body part 120 of a user by a light emitter (not shown) and reflected from the body part of the user, but also ambient light irradiated from an external light source 130 such as the sun or a lamp. Because the intensity or brightness of the ambient light irradiated from the external light source 130 can vary greatly according to measurement conditions, it can be difficult to maintain the amount (intensity or brightness) of light received by the light receiver 110.

[0009] The brightness (i.e., illuminance) of light sensed by the light receiver 110 needs to be constantly maintained in order to accurately measure PPG signals (and an oxygen saturation level). In order to address this problem, a shielding structure has been employed in the prior art to shield the parts where light is irradiated and sensed from the external light source. According to the prior art, this causes spatial constraints requiring the shield structure to contain all of the components including the light emitter for irradiating light and the light receiver for sensing light, which causes the size of the measurement apparatus to become excessively large due to the shielding structure.

[0010] Therefore, a technique for accurately measuring PPG signals (and an oxygen saturation level) in a situation in which brightness of ambient light is not constant due to external light sources is desirable.

**SUMMARY**

[0011] Provided herein are methods, apparatuses, and non-transitory computer-readable recording media for accurately measuring photoplethysmography (PPG) signals in a situation in which brightness of ambient light is not constant due to external light sources, by irradiating light of a first wavelength range and light of a second wavelength range onto a body part of a user through a first filter and a second filter, respectively; sensing light of the first wavelength range entering through the first filter and light of the second wavelength range entering through the second filter, respectively; measuring a first illuminance of the light of the first wavelength range entering through the first filter and a second illuminance of the light of the second wavelength range entering through the second filter, respectively; generating a first PPG signal corresponding to the sensed light of the first wavelength range and a second PPG signal corresponding to the sensed light of the second wavelength range; and when a difference between a predetermined reference illuminance and at least one of the first and second measured illuminances is not less than a predetermined level, correcting at least one of the first and second PPG signals with reference to a relative relationship between the predetermined reference illuminance and at least one of the first and second measured illuminances.

[0012] According to one exemplary embodiment, there is provided a method for measuring photoplethysmography (PPG) signals, including the steps of: irradiating light of a first wavelength range and light of a second wavelength range onto a body part of a user, respectively; sensing light of the first wavelength range entering through a first filter and light of the second wavelength range entering through a second filter, respectively, and measuring a first illuminance of the light of the first wavelength range entering through the first filter and a second illuminance of the light of the second

wavelength range entering through the second filter, respectively; generating a first PPG signal corresponding to the sensed light of the first wavelength range and a second PPG signal corresponding to the sensed light of the second wavelength range; and when a difference between a predetermined reference illuminance and at least one of the first and second measured illuminances is not less than a predetermined level, correcting at least one of the first and second PPG signals with reference to a relative relationship between the predetermined reference illuminance and at least one of the first and second measured illuminances.

**[0013]** According to another aspect of the invention, there is provided an apparatus for measuring photoplethysmography

**[0014]** (PPG) signals, comprising: a first light emitter and a second light emitter configured to irradiate light of a first wavelength range and light of a second wavelength range onto a body part of a user, respectively; a first light receiver and a second light receiver configured to sense light of the first wavelength range entering through a first filter and light of the second wavelength range entering through a second filter, respectively; a first illuminance sensor and a second illuminance sensor configured to measure a first illuminance of the light of the first wavelength range entering through the first filter and a second illuminance of the light of the second wavelength range entering through the second filter, respectively; and a calculator configured to generate a first PPG signal corresponding to the sensed light of the first wavelength range and a second PPG signal corresponding to the sensed light of the second wavelength range, and when a difference between a predetermined reference illuminance and at least one of the first and second measured illuminances is not less than a predetermined level, configured to correct at least one of the first and second PPG signals with reference to a relative relationship between the predetermined reference illuminance and at least one of the first and second measured illuminances.

**[0015]** In addition, there are further provided other methods and apparatuses to implement the invention, as well as non-transitory computer-readable recording media having stored thereon computer programs for executing the methods.

**[0016]** According to the invention, PPG signals may be accurately measured even in a situation in which brightness of ambient light is not constant due to external light sources.

**[0017]** According to the invention, accuracy of a variety of biological information derivable from PPG signals may be improved.

**[0018]** According to the invention, a signal corresponding to sensed light may be adaptively corrected on the basis of a measured illuminance, thereby preventing spatial constraints caused by a conventional shielding structure and allowing a PPG signal measurement apparatus to be easily installed in a wearable device having a small size and limited shape.

#### BRIEF DESCRIPTION OF THE DRAWINGS

**[0019]** FIG. 1 illustratively shows a situation in which photoplethysmography (PPG) signals are measured according to the prior art.

**[0020]** FIG. 2 schematically shows the configuration of an entire system according to one embodiment of the invention.

**[0021]** FIG. 3 illustratively shows the internal configuration of a PPG signal measurement apparatus according to one embodiment of the invention.

**[0022]** FIG. 4 illustratively shows the appearance of the PPG signal measurement apparatus according to one embodiment of the invention.

**[0023]** FIG. 5 illustratively shows how PPG signals and an oxygen saturation level are measured according to one embodiment of the invention.

#### DETAILED DESCRIPTION

**[0024]** In the following detailed description of the present invention, references are made to the accompanying drawings that show, by way of illustration, specific embodiments in which the invention may be practiced. These embodiments are described in sufficient detail to enable those skilled in the art to practice the invention. It is to be understood that the various embodiments of the invention, although different from each other, are not necessarily mutually exclusive. For example, specific shapes, structures and characteristics described herein may be implemented as modified from one embodiment to another without departing from the spirit and scope of the invention. Furthermore, it shall be understood that the locations and/or arrangements of individual elements within each of the disclosed embodiments may also be modified without departing from the spirit and scope of the invention. Therefore, the following detailed description is not to be taken in a limiting sense, and the scope of the invention, if properly described, is limited only by the appended claims together with all equivalents thereof. In the drawings, like reference numerals refer to the same or similar functions throughout the several views.

**[0025]** Although one or more exemplary embodiments are described as using a plurality of units to perform the exemplary processes, it is understood that the exemplary processes can also be performed by one or plurality of modules. Additionally, it is understood that the term controller/control unit refers to a hardware device that includes a memory and a processor. The memory is configured to store the modules and the processor is specifically configured to execute said modules to perform one or more processes which are described further below. Any units described herein can be devices and/or structures that are configured to perform the stated functions. Unless specifically stated or obvious from context, as used herein, the term "about" is understood as within a range of normal tolerance in the art, for example within 2 standard deviations of the mean. "About" can be understood as within 10%, 9%, 8%, 7%, 6%, 5%, 4%, 3%, 2%, 1%, 0.5%, 0.1%, 0.05%, or 0.01% of the stated value. Unless otherwise clear from the context, all numerical values provided herein are modified by the term "about."

**[0026]** An entire system for measuring photoplethysmography (PPG) signals according to one embodiment will be discussed in detail below.

**[0027]** FIG. 2 schematically shows the configuration of the entire system according to one embodiment.

**[0028]** As shown in FIG. 2, the entire system according to one embodiment can include a communication network **100**, a PPG signal measurement apparatus **200**, and a device **300**.

**[0029]** First, the communication network **100** according to one embodiment can be implemented regardless of communication modality such as wired and wireless communications, and can be constructed from a variety of communi-

communication networks, such as local area networks (LANs), metropolitan area networks (MANs), and wide area networks (WANs). The communication network **100** described herein can include known short-range wireless communication networks such as Wi-Fi, Wi-Fi Direct, LTE Direct, and Bluetooth. However, the communication network **100** is not necessarily limited thereto, and may at least partially include known wired/wireless data communication networks, known telephone networks, or known wired/wireless television communication networks.

**[0030]** Next, the PPG signal measurement apparatus **200** according to one embodiment can function to accurately measure PPG signals in a situation in which brightness of ambient light is not constant due to external light sources, by irradiating light of a first wavelength range and light of a second wavelength range onto a body part of a user through a first filter and a second filter, respectively; sensing light of the first wavelength range entering through the first filter and light of the second wavelength range entering through the second filter, respectively; measuring a first illuminance of the light of the first wavelength range entering through the first filter and a second illuminance of the light of the second wavelength range entering through the second filter, respectively; generating a first PPG signal corresponding to the sensed light of the first wavelength range and a second PPG signal corresponding to the sensed light of the second wavelength range; and when a difference between a predetermined reference illuminance and at least one of the first and second measured illuminances is not less than a predetermined level, correcting at least one of the first and second PPG signals with reference to a relative relationship between the predetermined reference illuminance and at least one of the first and second measured illuminances.

**[0031]** The functions of the PPG signal measurement apparatus **200** will be discussed in more detail below. Meanwhile, although the PPG signal measurement apparatus **200** has been described as above, the above description is illustrative and it will be apparent to those skilled in the art that at least some of the functions or components required for the PPG signal measurement apparatus **200** can be implemented or included in the device **300**, as necessary.

**[0032]** Lastly, the device **300** according to one embodiment is digital equipment that can function to connect to and then communicate with the PPG signal measurement apparatus **200**, and any type of digital equipment having a memory means and a microprocessor for computing capabilities can be adopted as the device **300**. The device **300** can be a wearable device such as a smart glass, a smart watch, a smart band, a smart ring, and/or a smart necklace, or can be a device such as a smart phone, a smart pad, a desktop computer, a notebook computer, a workstation, a personal digital assistant (PDA), a web pad, and/or a mobile phone. According to one embodiment, the device **300** can include a sensing means, such as one or more sensors, for acquiring a biosignal from a human body, and a display means, such as one or more displays, for providing biological information to a user.

**[0033]** In addition, according to one embodiment, the device **300** can further include an application program for performing the functions provided herein. The application can reside in the device **300** in the form of a program module. The nature of the program module can be generally similar to those of a calculator **250**, a communicator **260**, and a controller **270** of the PPG signal measurement apparatus

**200** to be described below. Here, at least a part of the application can be replaced with a hardware and/or firmware device that can perform substantially equal or equivalent functions, as necessary.

#### Configuration of the PPG Signal Measurement Apparatus

**[0034]** Hereinafter, the internal configuration of the PPG signal measurement apparatus **200** configured in part to implement some or all of the functions of the respective components thereof will be discussed.

**[0035]** FIG. 3 illustrates the internal configuration of the PPG signal measurement apparatus according to one embodiment.

**[0036]** Referring to FIG. 3, the PPG signal measurement apparatus **200** according to one embodiment can include a light emitter **210**, a light receiver **220**, an illuminance sensor **230**, a filter **240**, a calculator **250**, a communicator **260**, and a controller **270**. According to one embodiment, at least some of the calculator **250**, the communicator **260**, and the controller **270** can be program modules to communicate with an external system (not shown). The program modules can be included in the PPG signal measurement apparatus **200** in the form of operating systems, application program modules and other program modules, while they may be physically stored in a variety of known storage devices. Further, the program modules can also be stored in a remote storage device that can communicate with the PPG signal measurement apparatus **200**. Meanwhile, such program modules can include, but are not limited to, routines, sub-routines, programs, objects, components, data structures and the like for performing specific tasks or executing specific abstract data types as will be described below.

**[0037]** FIG. 4 illustrates the appearance of the PPG signal measurement apparatus according to one embodiment.

**[0038]** First, according to one embodiment, the light emitter **210** can function to irradiate light of a first wavelength range and light of a second wavelength range onto a body part (e.g., a finger, wrist, etc.) of a user for which measurement is to be carried out. Specifically, the light emitter **210** according to one embodiment can include a first light emitter **211** for emitting light of the first wavelength range and a second light emitter **212** for emitting light of the second wavelength range, and can consist of light emitting diodes (LEDs) for generating the light of the first wavelength range or the light of the second wavelength range according to a predetermined cycle. For example, the light of the first wavelength range can include visible light of a wavelength range of about 490 nm to 780 nm, and the light of the second wavelength range can include infrared light of a wavelength range of about 800 nm to 980 nm.

**[0039]** Further, according to one embodiment, the light of the first wavelength range and the light of the second wavelength range emitted from the light emitter **210** can be irradiated onto the body part of the user through the first filter **241** and the second filter **242**, respectively. Here, the first and second filters **241** and **242** can consist of filters for selectively transmitting the light of the first wavelength range and the light of the second wavelength range, respectively.

**[0040]** Next, according to one embodiment of the invention, the light receiver **220** can function to sense light of the first wavelength range and light of the second wavelength range, respectively. Specifically, the light receiver **220**

according to one embodiment can include a first light receiver **221** for sensing light of the first wavelength range and a second light receiver **222** for sensing light of the second wavelength range, and can include photodiodes for sensing the light of the first wavelength range or the light of the second wavelength range. According to one embodiment, the light sensed by the light receiver **220** can include the light irradiated by the light emitter **210** and reflected from the body part of the user and ambient light irradiated from external light sources.

**[0041]** Further, according to one embodiment, the light of the first wavelength range and the light of the second wavelength range sensed by the light receiver **220** can enter through the first and second filters **241** and **242**, respectively. As described above, the first and second filters **241** and **242** may consist of filters for selectively transmitting the light of the first wavelength range and the light of the second wavelength range, respectively.

**[0042]** Next, according to one embodiment, the illuminance sensor **230** can function to measure a first illuminance of the light of the first wavelength range entering through the first filter **241** and a second illuminance of the light of the second wavelength range entering through the second filter **242**, respectively. Specifically, the illuminance sensor **230** according to one embodiment can include a first illuminance sensor **231** for sensing the first illuminance and a second illuminance sensor **232** for sensing the second illuminance, and the first and second illuminance sensors **231** and **232** can be disposed around the first and second light receivers **221** and **222**, respectively.

**[0043]** Next, according to one embodiment, the calculator **250** can function to generate a first PPG signal corresponding to the light of the first wavelength range and a second PPG signal corresponding to the light of the second wavelength range.

**[0044]** Further, according to one embodiment, when the difference between a predetermined reference illuminance and at least one of the first and second measured illuminances is not less than a predetermined level, the calculator **250** can function to correct at least one of the first and second PPG signals with reference to a relative relationship between the predetermined reference illuminance and at least one of the first and second measured illuminances.

**[0045]** Specifically, the calculator **250** according to one embodiment can perform correction to scale the intensity of at least one of the first and second PPG signals on the basis of the relative ratio of at least one of the first and second measured illuminances and the predetermined reference illuminance. For example, when the first illuminance measured by the first illuminance sensor **231** is about 2,000 lux and the predetermined reference illuminance is about 1,000 lux, then the intensity of the first PPG signal corresponding to the light of the first wavelength range sensed by the first light receiver **221** can be scaled by about  $\frac{1}{2}$ . For another example, when the second illuminance measured by the second illuminance sensor **232** is about 2,000 lux and the predetermined reference illuminance is about 1,000 lux, then the intensity of the second PPG signal corresponding to the light of the second wavelength range sensed by the second light receiver **222** can be scaled by about  $\frac{1}{3}$ .

**[0046]** PPG signals can thus be accurately measured in a situation in which brightness of ambient light is not constant due to external light sources, without employing a conven-

tional shielding structure causing spatial constraints and consequently making accurate measurement easier, simpler, and less expensive.

**[0047]** Further, according to one embodiment, the calculator **250** may function to calculate a blood oxygen saturation level in the body part of the user with reference to the first and second PPG signals corrected as above.

**[0048]** Specifically, the calculator **250** according to one embodiment can calculate the oxygen saturation level on the basis of a model for oxygen saturation level calculation, which is applicable when the illuminance of the sensed light matches the predetermined reference illuminance. The first and second PPG signals whose intensities are adaptively corrected on the basis of a predetermined reference illuminance as described above can be applied right to the model for oxygen saturation level calculation, and thus the calculator **250** according to one embodiment can calculate the oxygen saturation level with reference to the first and second PPG signals corrected as above and the model for oxygen saturation level calculation.

**[0049]** For example, the model for oxygen saturation level calculation according to one embodiment can be a model for calculating oxygen content of hemoglobin in blood on the basis of the difference between AC components of the first PPG signal (i.e., the signal corresponding to red light) and the second PPG signal (i.e., the signal corresponding to infrared light) corrected as above. However, it is noted that the model for oxygen saturation level calculation is not limited thereto, and can be changed without limitation as long as the objects discussed above can be achieved.

**[0050]** FIG. 5 illustrates how an oxygen saturation level is measured according to one embodiment.

**[0051]** Referring to FIG. 5, the first and second light emitters **211** and **212** according to one embodiment can generate and irradiate red light of a first wavelength range and infrared (IR) light of a second wavelength range onto a body part **120** of a user, respectively. The first and second light receivers **221** and **222** can sense red light of the first wavelength range and infrared light of the second wavelength range reflected from the body part of the user or irradiated from external light sources, respectively.

**[0052]** Referring further to FIG. 5, the first and second illuminance sensors **231** and **232** according to one embodiment can be disposed around the first and second light receivers **221** and **222**, respectively, and may measure the illuminance of the red light of the first wavelength range and that of the infrared light of the second wavelength range.

**[0053]** Referring further to FIG. 5, the calculator **250** according to one embodiment can generate a first PPG signal corresponding to the sensed light of the first wavelength range and a second PPG signal corresponding to the sensed light of the second wavelength range. Further, the calculator **250** according to one embodiment can perform correction to scale the intensity of at least one of the first and second PPG signals on the basis of the relative ratio of a predetermined reference illuminance and at least one of the first and second measured illuminances.

**[0054]** Referring further to FIG. 5, the calculator **250** according to one embodiment can calculate a blood oxygen saturation level of the user with reference to the first and second PPG signals corrected as above.

**[0055]** Next, the communicator **260** according to one embodiment can function to enable the PPG signal measurement apparatus **200** to communicate with an external device.

**[0056]** Lastly, the controller **270** according to one embodiment can function to control data flow among the light emitter **210**, the light receiver **220**, the illuminance sensor **230**, the filter **240**, the calculator **250**, and the communicator **260**. That is, the controller **270** can control inbound data flow or data flow among the respective components of the PPG signal measurement apparatus **200**, such that the light emitter **210**, the light receiver **220**, the illuminance sensor **230**, the filter **240**, the calculator **250**, and the communicator **260** can carry out their particular functions, respectively.

**[0057]** The embodiments as described above can be implemented in the form of program instructions that can be executed by various computer components, and can be stored on a non-transitory computer-readable recording medium. The non-transitory computer-readable recording medium can include program instructions, data files, data structures and the like, separately or in combination. The program instructions stored on the non-transitory computer-readable recording medium can be specially designed and configured for the present invention and/or can be known and available to those skilled in the computer software field. Examples of the non-transitory computer-readable recording medium include the following: magnetic media such as hard disks, floppy disks and magnetic tapes; optical media such as compact disk-read only memory (CD-ROM) and digital versatile disks (DVDs); magneto-optical media such as floptical disks; and hardware devices such as read-only memory (ROM), random access memory (RAM) and flash memory, which are specially configured to store and execute program instructions. Examples of the program instructions include not only machine language codes created by a compiler or the like, but also high-level language codes that can be executed by a computer using an interpreter or the like. The above hardware devices can be configured to operate as one or more software modules to perform the processes of the present invention, and vice versa.

**[0058]** Although the present invention has been described in terms of specific items such as detailed elements as well as the limited embodiments and the drawings, they are only provided to help more general understanding of the invention, and the present invention is not limited to the above embodiments. It will be appreciated by those skilled in the art to which the present invention pertains that various modifications and changes can be made from the above description.

**[0059]** Therefore, the scope of the present invention is not limited to the above-described embodiments, and the entire scope of the appended claims and their equivalents will fall within the scope and spirit of the invention.

What is claimed is:

**1.** A method for measuring photoplethysmography (PPG) signals, comprising:

irradiating light of a first wavelength range and light of a second wavelength range onto a body part of a user, respectively;

sensing light of the first wavelength range entering through a first filter and light of the second wavelength range entering through a second filter, respectively, and measuring a first illuminance of the light of the first wavelength range entering through the first filter and a

second illuminance of the light of the second wavelength range entering through the second filter, respectively;

generating a first PPG signal corresponding to the sensed light of the first wavelength range and a second PPG signal corresponding to the sensed light of the second wavelength range; and

when a difference between a predetermined reference illuminance and at least one of the first and second measured illuminances is not less than a predetermined level, correcting at least one of the first and second PPG signals with reference to a relative relationship between the predetermined reference illuminance and at least one of the first and second measured illuminances.

**2.** The method of claim **1**, wherein, in the correcting step, an intensity of at least one of the first and second PPG signals is scaled on the basis of a relative ratio of the predetermined reference illuminance and at least one of the first and second measured illuminances when the difference between the predetermined reference illuminance and at least one of the first and second measured illuminances is not less than the predetermined level.

**3.** The method of claim **1**, further comprising:

calculating a blood oxygen saturation level in the body part of the user with reference to the first and second corrected PPG signals.

**4.** The method of claim **1**, wherein the first and second filters selectively transmit the light of the first wavelength range and the light of the second wavelength range, respectively.

**5.** The method of claim **1**, wherein the first wavelength range includes a wavelength range of about 490 nm to 780 nm, and the second wavelength range includes a wavelength range of about 800 nm to 980 nm.

**6.** The method of claim **1**, wherein the light of the first wavelength range and the light of the second wavelength range irradiated onto the body part of the user are irradiated onto the body part of the user through the first and second filters, respectively.

**7.** A non-transitory computer-readable recording medium having stored thereon a computer program for executing the method of claim **1**.

**8.** An apparatus for measuring photoplethysmography (PPG) signals, comprising:

a first light emitter and a second light emitter configured to irradiate light of a first wavelength range and light of a second wavelength range onto a body part of a user, respectively;

a first light receiver and a second light receiver configured to sense light of the first wavelength range entering through a first filter and light of the second wavelength range entering through a second filter, respectively;

a first illuminance sensor and a second illuminance sensor configured to measure a first illuminance of the light of the first wavelength range entering through the first filter and a second illuminance of the light of the second wavelength range entering through the second filter, respectively; and

a calculator configured to generate a first PPG signal corresponding to the sensed light of the first wavelength range and a second PPG signal corresponding to the sensed light of the second wavelength range, and when a difference between a predetermined reference illuminance and at least one of the first and second

measured illuminances is not less than a predetermined level, configured to correct at least one of the first and second PPG signals with reference to a relative relationship between the predetermined reference illuminance and at least one of the first and second measured illuminances.

9. The apparatus of claim 8, wherein the calculator is configured to scale an intensity of at least one of the first and second PPG signals on the basis of a relative ratio of the predetermined reference illuminance and at least one of the first and second measured illuminances when the difference between the predetermined reference illuminance and at least one of the first and second measured illuminances is not less than the predetermined level.

10. The apparatus of claim 8, wherein the calculator is configured to calculate a blood oxygen saturation level in the body part of the user with reference to the first and second corrected PPG signals.

11. The apparatus of claim 8, wherein the first and second filters selectively transmit the light of the first wavelength range and the light of the second wavelength range, respectively.

12. The apparatus of claim 8, wherein the first wavelength range includes a wavelength range of about 490 nm to 780 nm, and the second wavelength range includes a wavelength range of about 800 nm to 980 nm.

13. The apparatus of claim 8, wherein the light of the first wavelength range and the light of the second wavelength range irradiated onto the body part of the user are configured to be irradiated onto the body part of the user through the first and second filters, respectively.

\* \* \* \* \*

专利名称(译)	用于测量光电容积脉搏波信号的方法，装置和非暂时性计算机可读记录介质		
公开(公告)号	<a href="#">US20170020420A1</a>	公开(公告)日	2017-01-26
申请号	US15/215127	申请日	2016-07-20
[标]申请(专利权)人(译)	株式会社休一楼		
申请(专利权)人(译)	HUIINNO有限公司		
当前申请(专利权)人(译)	HUIINNO, CO., LTD.		
[标]发明人	SHIN MIN YONG CHOI YOON CHUL JEON JIN HONG SONG JEE YOUNG SHIN SEONG JUN		
发明人	SHIN, MIN-YONG CHOI, YOON CHUL JEON, JIN HONG SONG, JEE YOUNG SHIN, SEONG JUN		
IPC分类号	A61B5/1455 A61B5/00		
CPC分类号	A61B5/14552 A61B5/7278 A61B2562/0238 A61B5/7221 A61B5/7203 A61B5/7214		
优先权	1020150102695 2015-07-20 KR 1020160023632 2016-02-26 KR		
外部链接	<a href="#">Espacenet</a> <a href="#">USPTO</a>		

摘要(译)

本文提供了用于测量光电容积脉搏波描记 ( PPG ) 信号的方法，装置和非暂时性计算机可读记录介质。即使在由于外部光源而环境光的亮度不恒定的情况下也可以获得准确的PPG信号，并且可以提高从PPG信号导出的各种生物信息的精度。

