



(19) **United States**

(12) **Patent Application Publication**
Goering et al.

(10) **Pub. No.: US 2018/0184914 A1**
(43) **Pub. Date: Jul. 5, 2018**

(54) **BODY-WORN BIOMETRIC SENSOR**

A61B 5/04085 (2013.01); *A61B 5/0022*
(2013.01); *A61B 5/6832* (2013.01); *A61B*
5/1118 (2013.01)

(71) Applicant: **Vytal Corporation**, Wichita, KS (US)

(72) Inventors: **Jared Goering**, McPherson, KS (US);
Spencert Steinert, McPherson, KS
(US)

(57) **ABSTRACT**

(21) Appl. No.: **15/397,525**

(22) Filed: **Jan. 3, 2017**

Publication Classification

(51) **Int. Cl.**

A61B 5/0205 (2006.01)
A41D 1/00 (2006.01)
A61B 5/1455 (2006.01)
A61B 5/01 (2006.01)
A61B 5/11 (2006.01)
A61B 5/0408 (2006.01)
A61B 5/00 (2006.01)

(52) **U.S. Cl.**

CPC *A61B 5/02055* (2013.01); *A41D 1/002*
(2013.01); *A61B 5/14552* (2013.01); *A61B*
5/01 (2013.01); *A61B 2560/0214* (2013.01);

Systems and methods for tracking or viewing a user's physiological parameters before, during, and/or after physical activity. In some versions, a sensor device can be worn on a user's body and is configured to detect multiple physiological parameters and to wirelessly communicate with a mobile computing device. Optionally, the detected physiological parameters can be used to determine a selected set of work-out parameters, which can be concurrently displayed on the mobile computing device during the user's exercise/activity or after the exercise period. In some implementations, each of a plurality of users can wear a respective body-worn sensor device, and all of the sensors devices can wireless communicate with a designated mobile computing device for purposes of collectively (and concurrently) monitoring sets of physiological parameters for all of the users during the same workout, practice, or other activity.

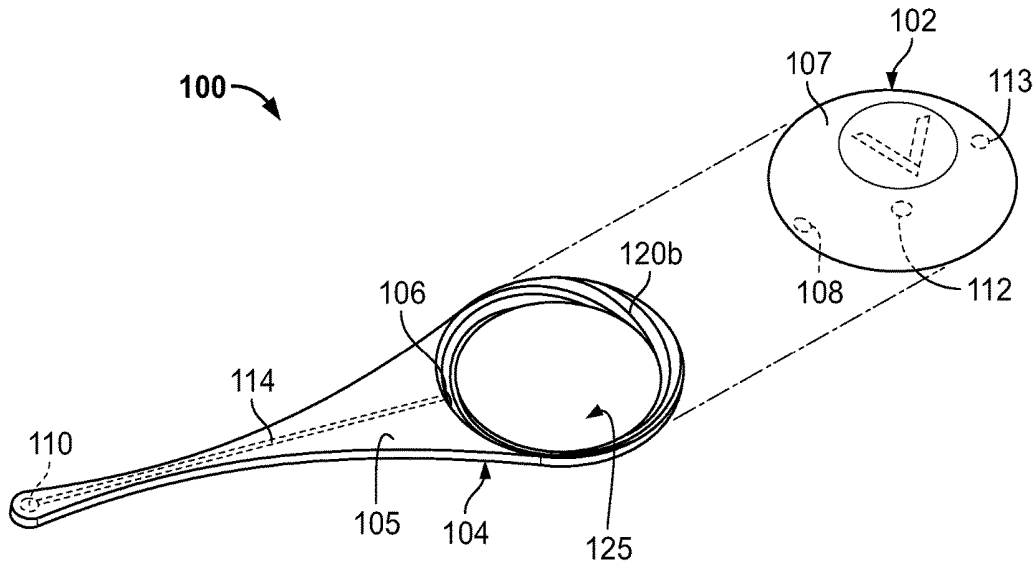

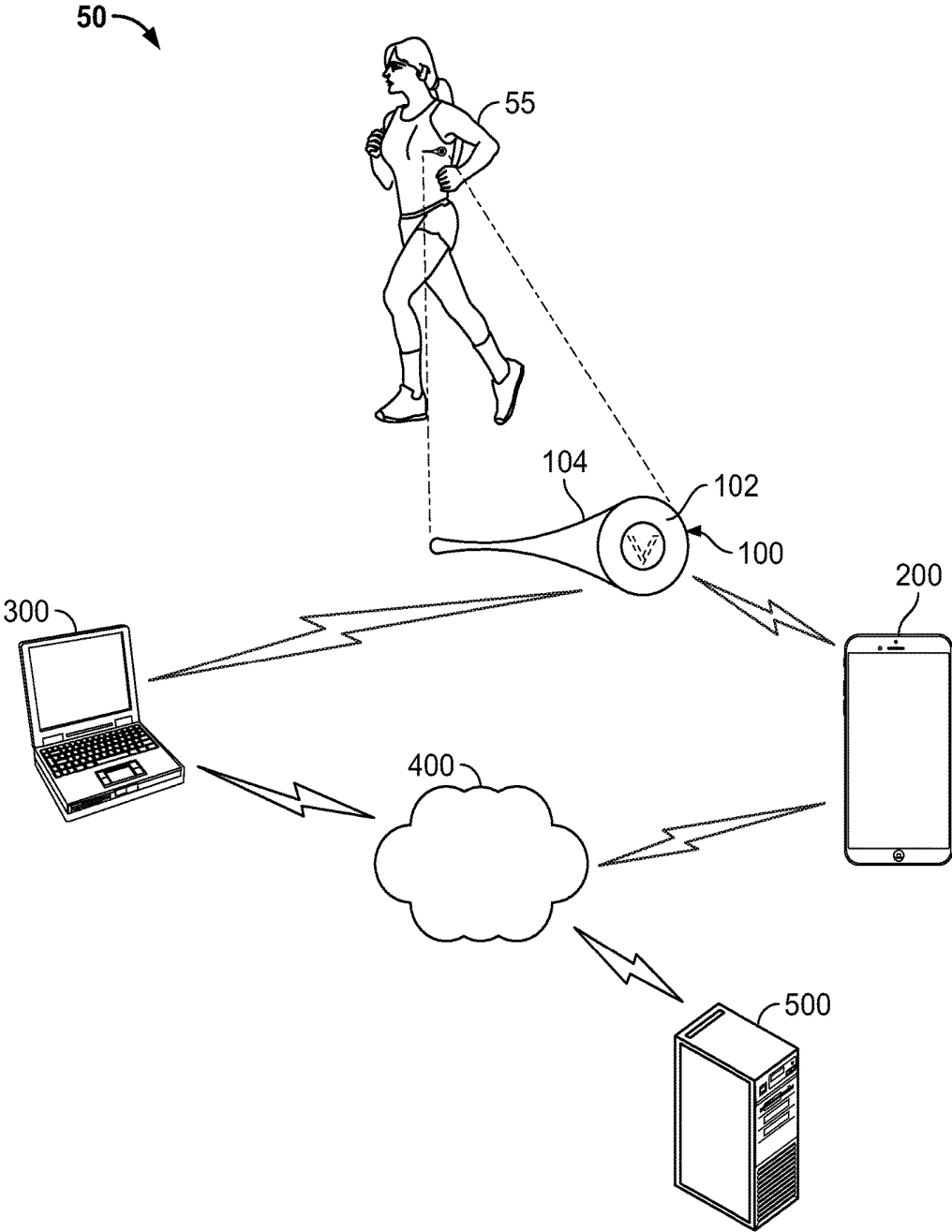

FIG. 1

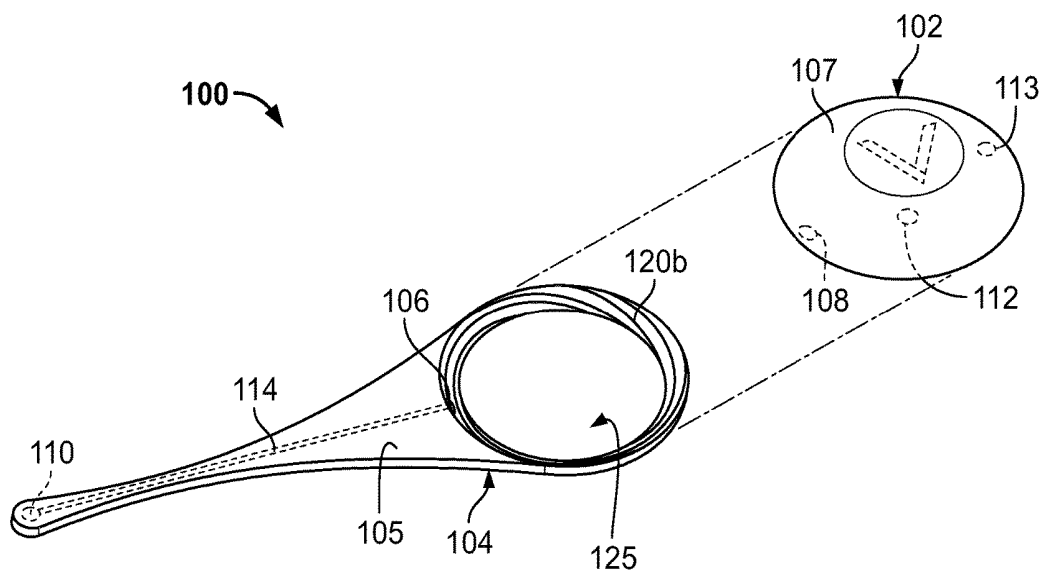

FIG. 2

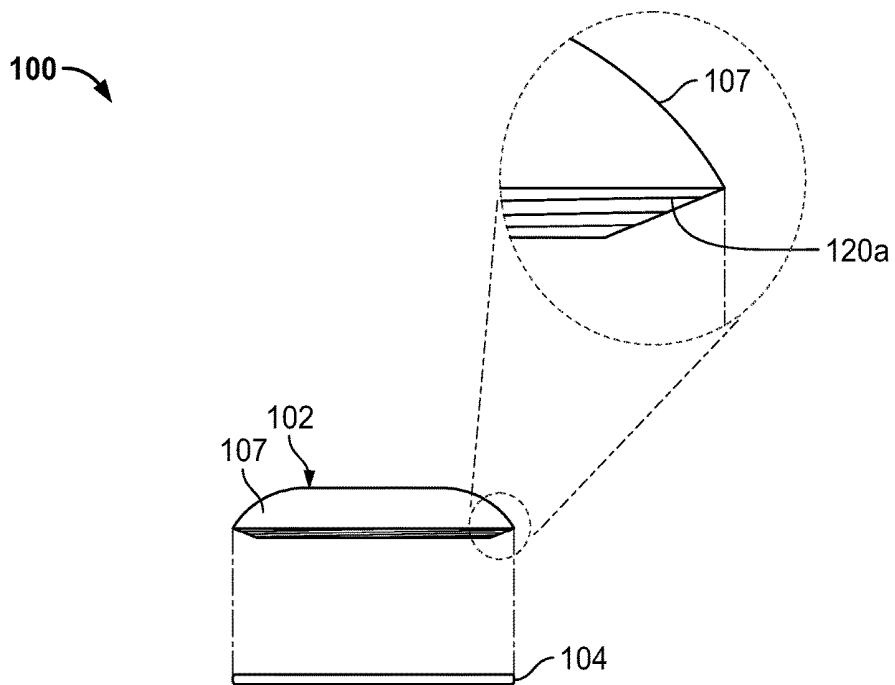

FIG. 3

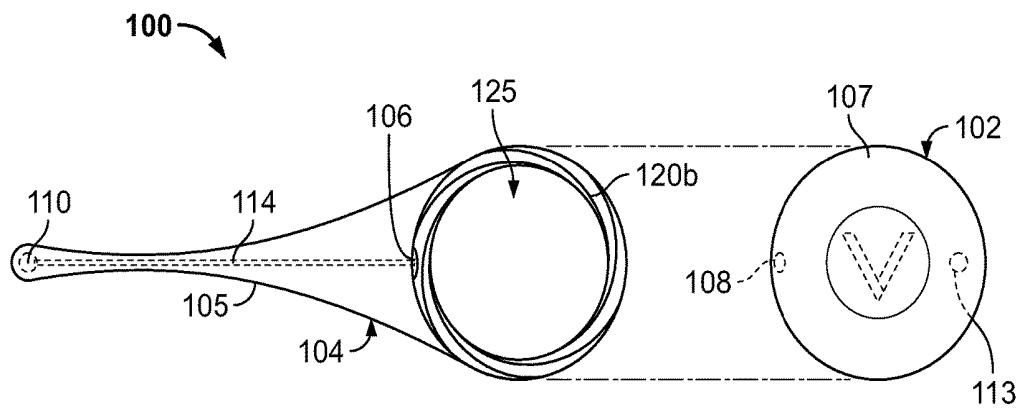

FIG. 4

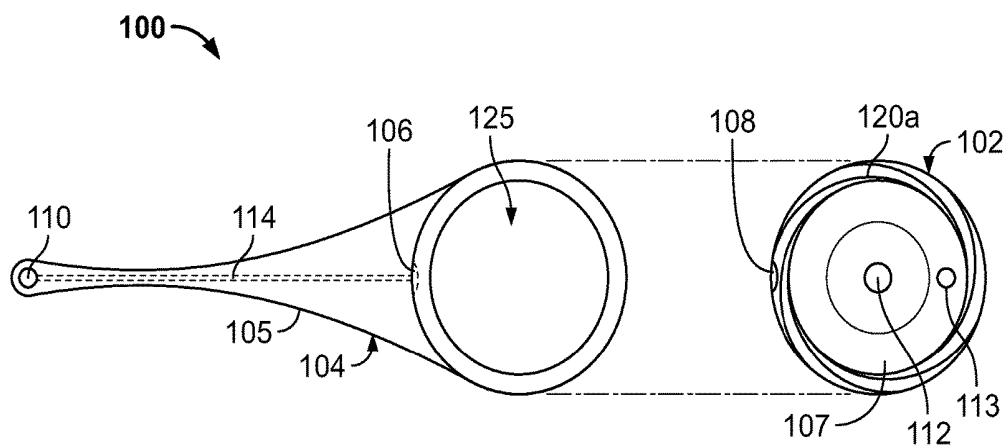

FIG. 5

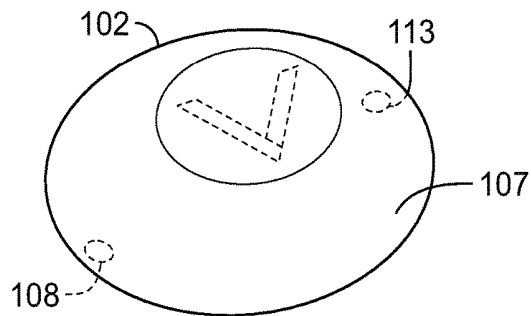

FIG. 6A

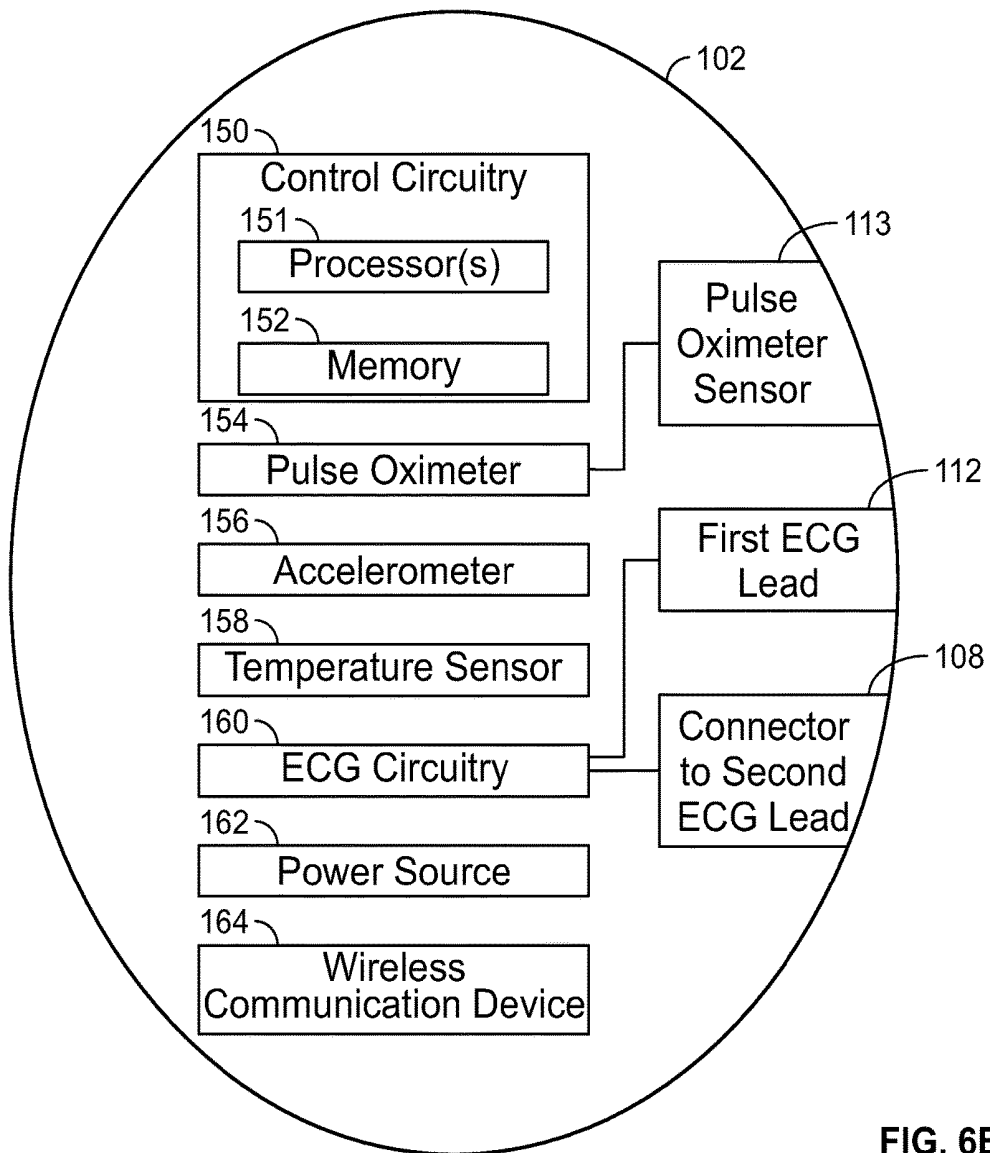

FIG. 6B

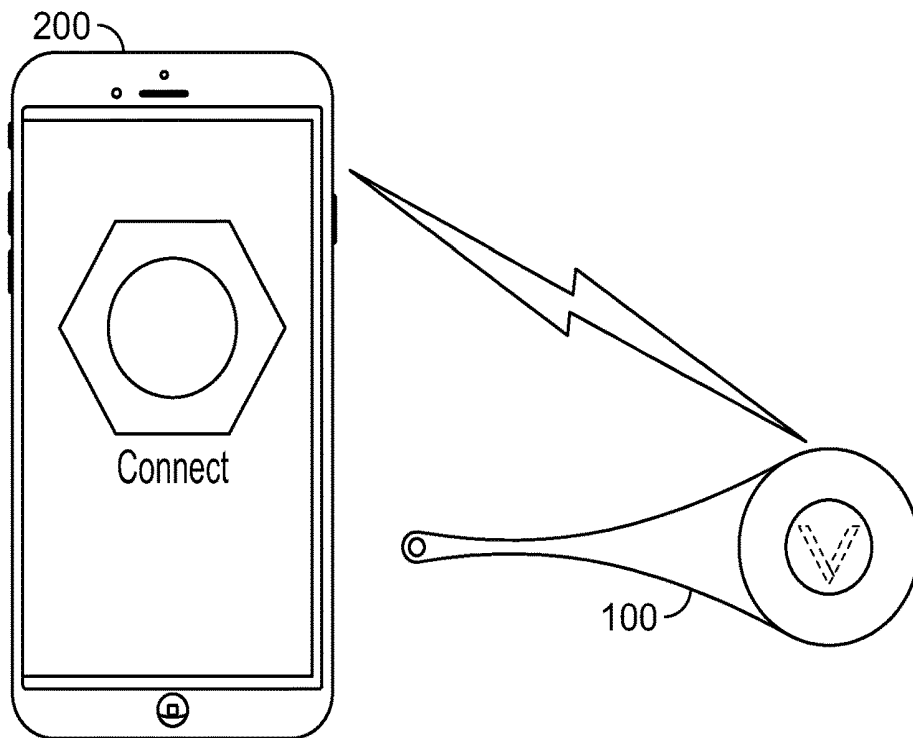

FIG. 7A

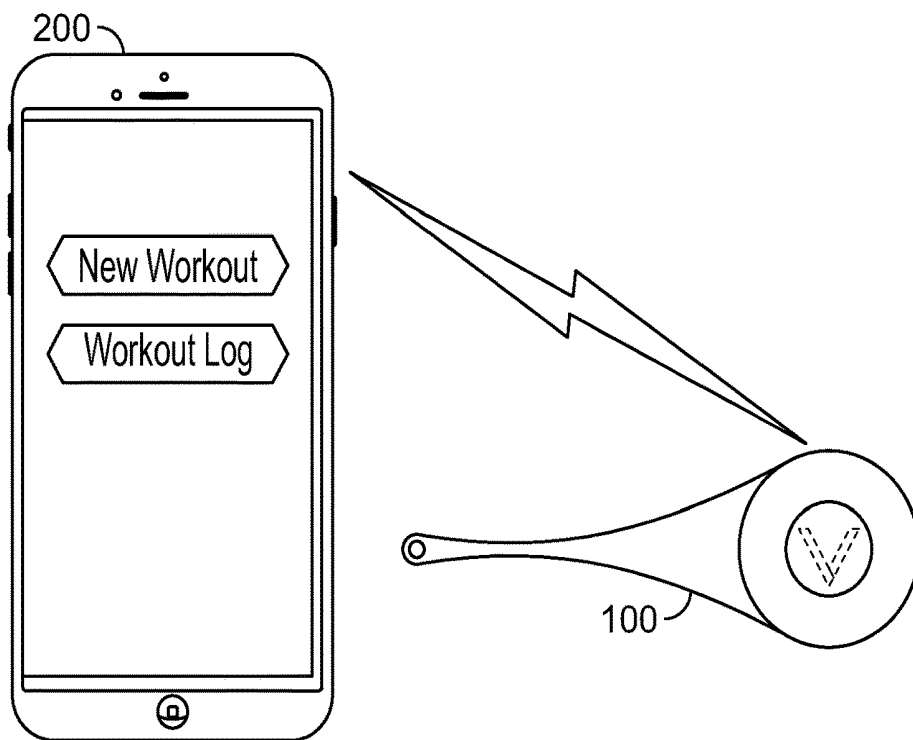

FIG. 7B

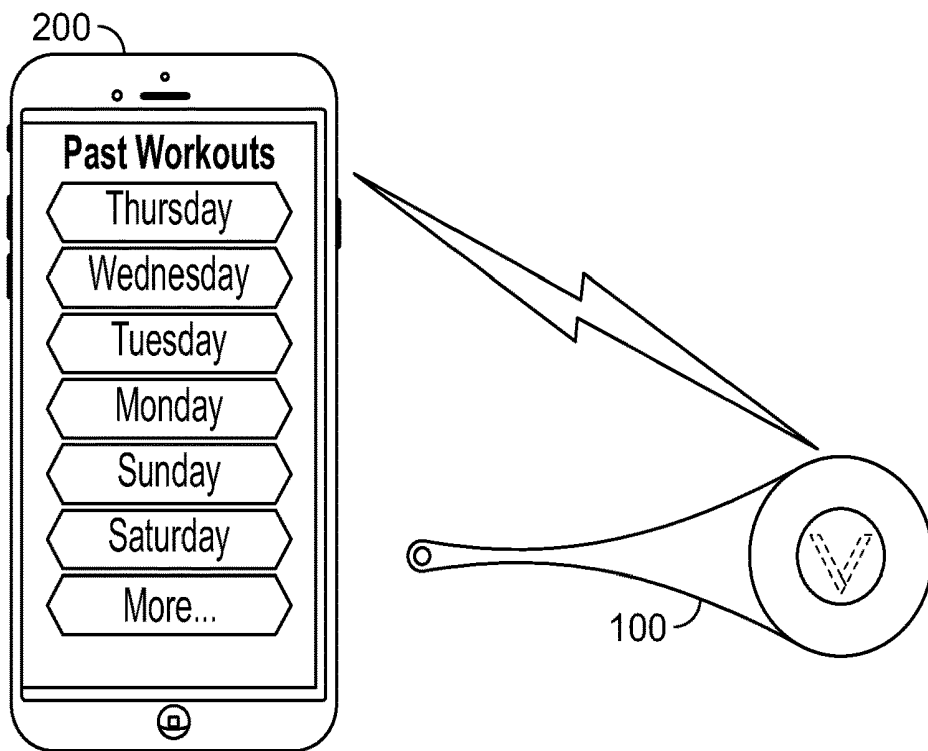

FIG. 7C

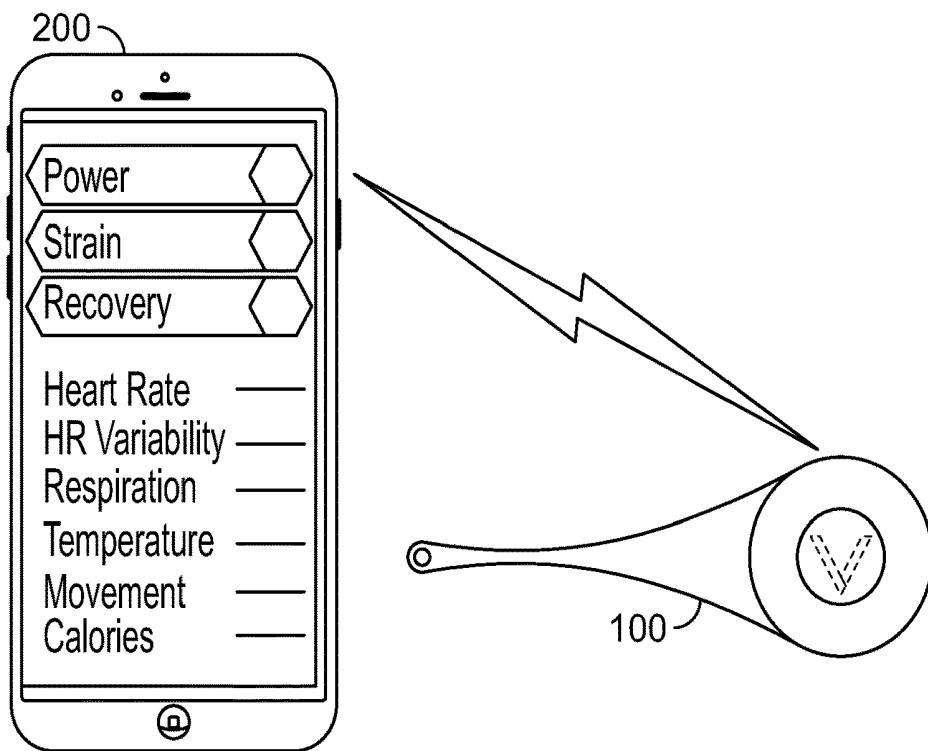

FIG. 7D

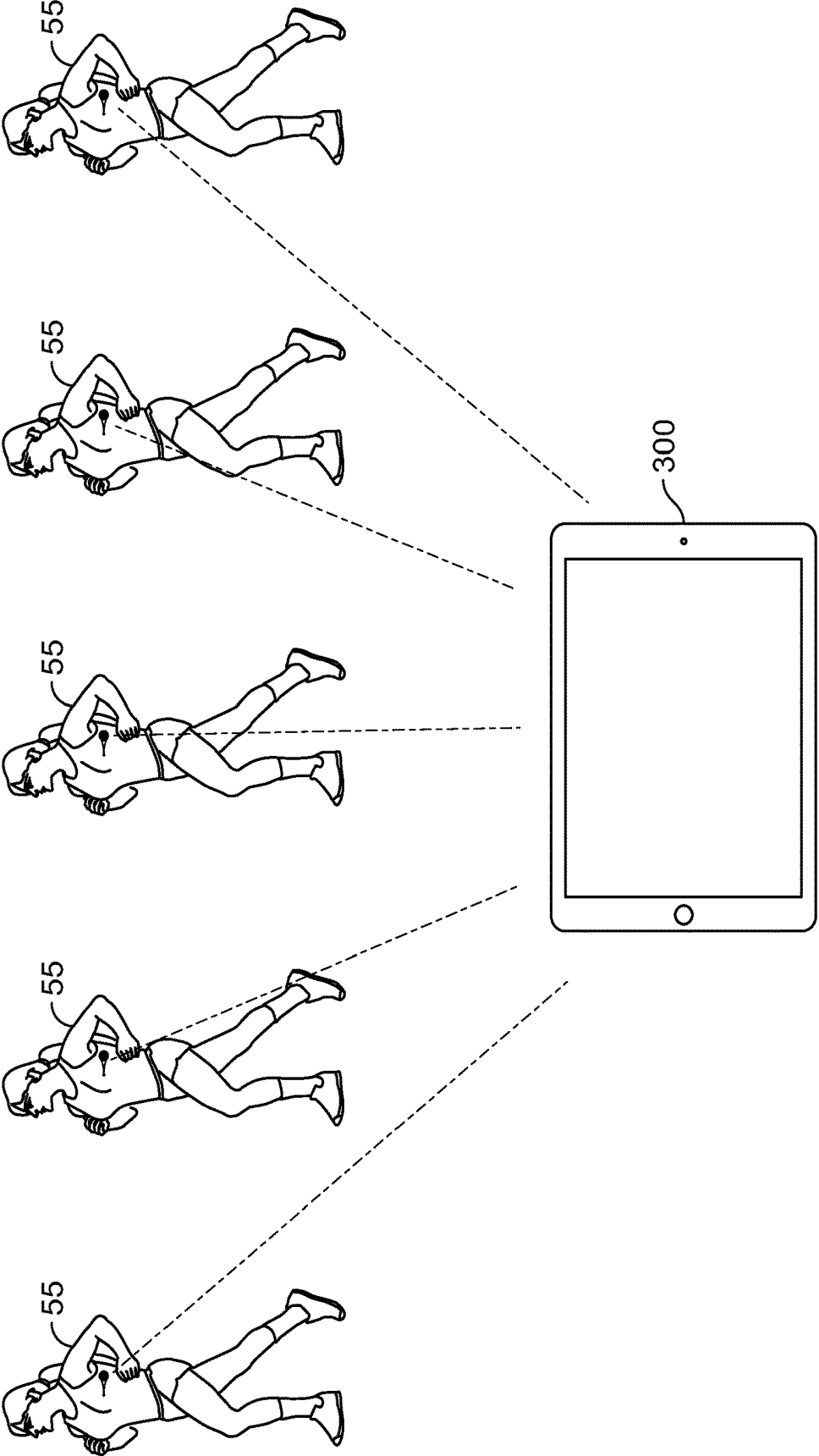

FIG. 8

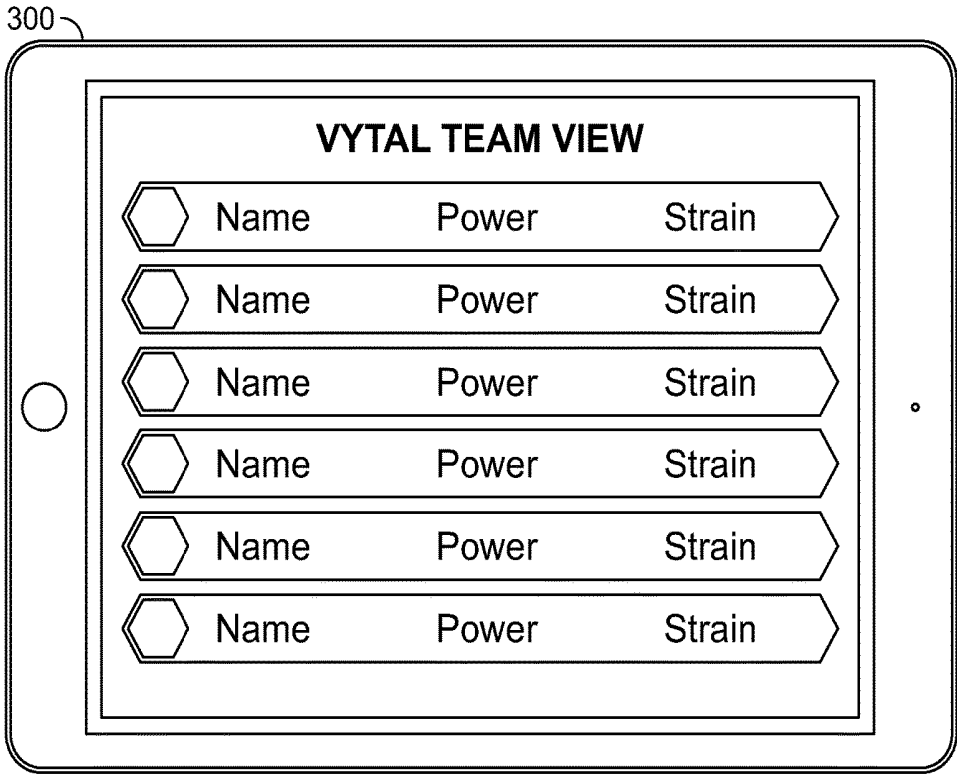

FIG. 9

BODY-WORN BIOMETRIC SENSOR

TECHNICAL FIELD

[0001] This document describes systems and methods for detecting and monitoring physiological parameters, for example, to provide personal or team fitness tracking during exercise or other physical activity.

BACKGROUND

[0002] When a person engages in physical activity, certain bodily process change, including pulse, breathing rate, blood pressure, and body temperature. In some circumstances, a user can carry a personal fitness tracking device, such as a pedometer, to track the user's activity levels over particular periods of time or throughout his or her normal daily activities. Such pedometer devices may be used to provide an estimate of the user's "steps" accumulated over time, the number of "staircases" climbed, and the number of calories used (which is usually calculated via an extrapolation calculation based upon the user's weight). In some cases, these estimated results can be displayed directly on the personal fitness tracking device or via a personal computing device. Such personal fitness tracking devices are commonly provided in a portable housing (including costly electronics and rechargeable batteries) that is mechanically clips to an article of clothing or carried in a pocket, which often leads to such devices being both costly and requiring reusability over many months or years.

SUMMARY

[0003] Some embodiments described herein provide a system and method for tracking and viewing a user's physiological parameters (such as a selected set of exercise parameters indicative of bodily functions during a workout or practice) before, during, and after physical activity. In some versions, a sensor device can be worn on a user's body and is configured to detect multiple physiological parameters and to wirelessly communicate with a mobile computing device, such as a smartphone, tablet, or portable computer. Optionally, the detected physiological parameters can be used to determine a selected set of work-out parameters, such as power, performance, strain, and recovery level, which can be concurrently displayed on the mobile computing device during the user's exercise/activity or after the exercise period for purposes of coaching, comparison to previous exercise periods, or comparison to other users performing the same exercise/activity. In some implementations, each of a plurality of users (e.g., each player on a team) can wear a respective body-worn sensor device, and all of the sensors devices can wireless communicate with a designated mobile computing device, such as a tablet device of a coach, trainer, or judge, for purposes of collectively (and concurrently) monitoring sets of physiological parameters for all of the users during the same workout, practice, or other activity.

[0004] In some embodiments, the sensor device may include a multi-piece design (e.g., a two-piece design in some examples described below) in which the pieces are configured to mechanically and releasably couple together prior to the user's physical activity and to detach from one another after the user's physical activity. Optionally, the body-worn sensor can have a two-piece configuration in which a first piece mechanically and releasably attaches to

a second piece, which is configured to adhere or otherwise attach to the user during the user's physical activity. For example, the first piece can have a housing that contains a power source, processor, memory, a pulse oximeter, an accelerometer, a temperature sensor, electrocardiogram (ECG) detection circuitry, and at least one ECG lead. Also, in this example, the second piece can include a flexible body configured to adhere to the user's skin, at least a second ECG lead, and a connection device for mechanically and releasably mating with the first piece and for providing an electrical connection from the second ECG lead to the first piece. Optionally, the second piece may have a structure that is disposable and non-reusable (e.g., a "single-use" component), while in other embodiments, the second piece may comprise a portion of a user's garment or other reusable body-worn article. Also, the first piece may optionally have a smaller size than the second piece and may be configured to be reused with a series of subsequent second pieces, for example, over a period of days. The body-worn sensor may include mechanical coupling for securing the first piece to the second piece, for example mating threads. The body-worn sensor may include physical structure for attaching to a user's body, for example adhesive.

[0005] In particular embodiments, the body-worn sensor may wirelessly communicate with a computing device, for example a smartphone, tablet, portable computer, or other computing device. The body-worn sensor may communicate with the user's computing device, a monitor's computing device (e.g., computing device of a coach, trainer, judge, or other monitor), or one or more computing devices connected to a computer network. The body-worn sensor may wirelessly communicate physiological parameters, for example blood pressure, pulse, body temperature, and repetitions of a particular physical activity. The computing device may display both physiological parameters and work-out parameters (e.g., parameters such as power, performance, strain, and recovery level), which may be determined based upon the physiological parameters and other factors. Work-out parameters may be determined in the body-worn sensor, in the computing device, or in a different device connected to a computing device via a network. Physiological parameters and work-out parameters may be stored on the network and accessible by the user or a monitor.

[0006] In further embodiments, a plurality of body-worn sensors can wirelessly and contemporaneously communicate with a designated computing device, such as the computing device of a coach, trainer, judge, or other monitor. The monitor's computing device may contemporaneously display physiological or work-out parameters corresponding to the plurality of sensors, which may be worn by a plurality of users competing or participating in a workout, sport, practice, exercise, or other physical activity. Optionally, the monitor may also be a user that wears one of the body-worn sensors.

[0007] Some or all of the embodiments described herein may provide one or more of the following advantages. First, some embodiments allow the user to engage in physical activity while wearing a body-worn sensor in a substantially unencumbered manner. This ensures that the user's physical activity would be nearly the same if performed without wearing the sensor.

[0008] Second, in some embodiments, a user engaged in physical activity can view physiological parameters and work-out parameters in real time on a computing device.

Such a configuration may beneficially assist the user in deciding whether and how to alter his or her physical activity for purposes of an enhanced/personalized training or purposes of safety.

[0009] Third, in some embodiments, a user can track multiple physical-activity sessions over time and compare the same set of physiological parameters and/or work-out parameters among the various physical-activity sessions. This allows a user to vary the number, scope, and intensity of physical-activity sessions as desired.

[0010] Fourth, in some embodiments a user can upload parameters (e.g., the user's physiological parameters and work-out parameters for a selected workout or other physical activity) via a network, enabling a monitor to remotely access and view the user's parameters and enabling the user to archive a larger set of physical-activity sessions in a remote computing device. Such a configuration provides the optional benefit of providing the monitor, who might be more knowledgeable than the user about physical activity even though the monitor is located remotely from the user, with an opportunity to give the user feedback about whether and how to vary the physical-activity sessions.

[0011] Fifth, in some embodiments, a monitor can contemporaneously track multiple users that are each wearing respective body-worn sensors in communication with the monitor's computing device. Such a configuration enables the monitor to compare performance among users and provide different feedback to different users in real time during the training session or other physical activity. Optionally, the monitor's computing device can wirelessly communicate directly with the body-worn sensors carried by the multiple users, or some or all of the body-worn sensors carried by the multiple users can wirelessly communicate with an intermediate computing device that then communicates with the monitor's computing device (e.g., via a network) so that the monitor can track the multiple users during a training session even though some users are located remotely from the monitor.

[0012] The details of one or more embodiments of the invention are set forth in the accompanying drawings and the description herein. Other features, objects, and advantages of the invention will be apparent from the description and drawings, and from the claims.

DESCRIPTION OF THE DRAWINGS

[0013] FIG. 1 is a diagram of a physical activity monitoring system, in accordance with some embodiments provided herein.

[0014] FIG. 2 is a perspective exploded view of a sensor device of the physical activity monitoring system of FIG. 1, in accordance with some embodiments.

[0015] FIG. 3 is a side view of the sensor device of FIG. 2.

[0016] FIG. 4 is a top view of the sensor device of FIG. 2.

[0017] FIG. 5 is a bottom view of the sensor device of FIG. 2.

[0018] FIG. 6A is a perspective view of a first piece of the sensor device of the physical activity monitoring system of FIG. 1, in accordance with some embodiments.

[0019] FIG. 6B is a diagram of internal circuitry and sensor elements housed within the first piece of the sensor device of the physical activity monitoring system of FIG. 1, in accordance with some embodiments.

[0020] FIGS. 7A-7D illustrate example screen shots of a user's computing device of the physical activity monitoring system of FIG. 1, in accordance with some embodiments.

[0021] FIG. 8 depicts a plurality of body-worn sensors in communication with a monitor's computing device of the physical activity monitoring system of FIG. 1, in accordance with some embodiments.

[0022] FIG. 9 illustrates an example screen shot of the monitor's computing device of FIG. 9, in accordance with some embodiments.

DETAILED DESCRIPTION OF ILLUSTRATIVE EMBODIMENTS

[0023] Referring to FIG. 1, some embodiments of a system 50 include a sensor device 100 worn by a user 55 and configured to wirelessly communicate with one or more computing devices 200 and 300, for example, using a short-range communication protocol. As will be described further below, the sensor device 100, which in this embodiment is a body-worn sensor, is equipped with one or more sensor instruments configured to measure one or more physiological parameters of the user 55, and can wirelessly communicate information relating to the measured parameters to the other external devices 200 and 300. The computing devices in communication with the body-worn sensor 100 are dependent on the configuration of the system 50. For example, in some embodiments the system 50 can optionally include one or more of a user's computing device 200, a monitor's computing device 300, a remote server 500 connected to device 200 or 300 via a network 400 (such as the Internet), and other computing devices equipped to receive and store information generated from the sensor device 100. However, such external devices are optional, and some embodiments of the system 50 may have none of, or only a subset of, these aforementioned external devices and networks 200, 300, 400, and 500.

[0024] In particular embodiments, the sensor device 100 wirelessly communicates with at least one computing device 200/300, such as a smartphone, tablet, portable computer, or other computing device. Preferably, each of the computing devices 200/300 is equipped with a wireless communication device (e.g., a short-range communication protocol such as Bluetooth or near-field communication (NFC), a wifi communication device for RF communication with a local wireless network, or the like). As described in more detail below, the sensor device 100 may communicate with the user's computing device 200, the monitor's computing device 300 (e.g., computing device of a coach, trainer, judge, or other monitor), or a one or more computing devices 500 connected to a network 400 for purposes of providing real-time information of the user's physiological parameters during a physical-activity session. For example, the sensor device 100 may be in the form of a body-worn sensor that wirelessly communicates physiological parameters selected from the group consisting of blood pressure, pulse rate, body temperature, and repetitions of a particular physical activity (e.g., steps, lifts, cycles, or the like). The computing device 200, 300, or 500 may display both physiological parameters and work-out parameters, which can be calculated based at least partially upon the physiological parameters detected by the sensor device 100. The work-out parameters may include parameters such as power, performance, strain, and recovery level, any or all of which are preferably determined at the computing device 200, 300, or 500 (or may alternatively be

determined at the sensor device **100** and communicated therefrom). Additionally, the physiological parameters and work-out parameters may be stored at the computing device **200**, **300**, or **500** for subsequent access by the user or a monitor.

[0025] Briefly, in use, the system **50** can provide for tracking and viewing a selected set of exercise parameters indicative of the user's bodily functions during a workout, training session, athletic practice, or other physical activity, which can be monitored and viewed in real time during the user's physical activity and also accessed after the physical activity. For example, the sensor device **100** can be adhered to an athlete's skin during a training session so that a set of sensor instruments (e.g., a pulse oximeter, an accelerometer, a temperature sensor, and an ECG sensing circuit) are mounted to the athlete and arranged to detect a set of parameters. As described in connection with FIGS. 7A-D, the detected physiological parameters can be used to determine a selected set of work-out parameters (e.g., power, performance, strain, and recovery level), and some or all of the physiological parameters and work-out parameters can be concurrently displayed on the mobile computing device **200**, **300** during the user's exercise/activity or after the exercise period for purposes of coaching, comparison to previous exercise periods, or comparison to other users performing the same exercise/activity. As described in connection with FIGS. 8-9, a plurality of users **55** (e.g., each player on a team, competitors in a competition, or another set of users) can wear a respective sensor device **100**, and all of the sensor devices **100** can wirelessly communicate with a designated mobile computing device **300**, such as a tablet device of a coach, trainer, or judge, for purposes of collectively (and concurrently) monitoring sets of physiological parameters for all of the users during the same workout, practice, competition, or other activity.

[0026] Referring now to FIGS. 1-2, some embodiments of the sensor device **100** may include a multi-piece configuration in which a user can mechanically and releasably couple the pieces together prior to the user's physical activity and can detach the pieces from one another after the user's physical activity. For example, in this embodiment, the sensor device **100** comprises a first piece **102** and a second piece **104**. As shown in FIG. 2, the first piece **102** of the sensor device **100** mechanically and releasably attaches to the second piece **104**, and the second piece **104** has a flexible body **105** with an adhesive layer along its lower surface to adhere the user's skin during the user's physical activity. As described in more detail below, the first piece **102** has an external housing **107** that contains (preferably in a sealed, water-tight arrangement) at least a power source, processor, memory, a pulse oximeter, an accelerometer, a temperature sensor, and electrocardiogram (ECG) detection circuitry. The first piece **102** can further include at least a first ECG lead **112** (refer also to FIG. 5) connected to the ECG detection circuitry and exposed along the external housing **107** at a position to engage with the user's skin surface during use. Also, in this embodiment, the flexible body **105** of the second piece **104** has at least a second ECG lead **110** embedded therein with a contact region arranged at a position along the underside of the flexible body **105** to engage with the user's skin surface during use. As described in more detail below, the first and second pieces **102** and **104** have mating electrical connectors **106** and **108** to provide an electrical connection from the second ECG lead **110** to the

the ECG detection circuitry within the first piece **102**. The sensor device **100** may include mechanical releasably coupling **120**, such as mating threads **120a-b**, so that the first piece **102** is capable of being physically mounted with and directly connected to the second piece **104** in a removable manner. In some embodiments, the first portion **102** may be reusable, and the second portion **104** may be disposable.

[0027] In this embodiment, the second piece **104** has a structure that is disposable and non-reusable (referred to as a "single-use" component). For example, the second piece **104** may have one or more structural features that hinder reuse of the second piece **104** after being worn by the user for a first period, such as the adhesive layer on the underside of the flexible body **105** being configured to maintain its bond with the user's skin only during the first period of time, but not a subsequent period of time after removal from the user's skin. Optionally, the flexible body **105** of the second piece **104** may have an outer periphery that provides a substantially "tear-drop" shape, which enhances a number of features of the sensor device **100** (e.g., providing a length-wise extension to space the second ECG lead **110** further away from the first ECG lead **112** (on the first piece **102**), providing an increased surface area along the underside of the flexible body for improved adhesion to the user's skin, and providing a streamlined shape so that the second piece **104** can be conveniently adhered in a variety of different locations on the user's body). In other embodiments, the second piece **104** may be a garment, or be part of a garment, such as a shirt. As shown in FIG. 2, the first piece **102** in this embodiment has a smaller size than the second piece **104** such that the first piece **102** is configured to nest within an aperture **125** of the second piece **104**. As described in more detail below, the first piece **102** may be configured to be reused with a series of subsequent second pieces **104**, for example, over a period of days, such as 3 days to 10 days, and preferably a period of 7 days to 10 days, at which time the battery life of the first piece **102** is expired. In alternative embodiments, the first piece **102** may be equipped with a rechargeable power source so that it can be reused over a greater period of time (e.g., greater than 10 days).

[0028] Referring now to FIGS. 2-5, sensor device **100** may include mechanical releasably coupling **120**, such as mating threads **120a-b**, so that the first piece **102** is capable of being physically mounted with and directly connected to the second piece **104** in a removable manner. In some embodiments, a first electrical connector **108** is positioned on the first piece **102** so that the first electrical connector **108** aligns with a second electrical connector **106** on the second piece **104** when the first piece **102** is coupled to the second piece **104**. In some embodiments, the first piece **102** is configured to nest within an aperture **125** in the second piece **104**. The aperture **125** can be equipped with a female thread, which is configured to mate with a corresponding male thread on the exterior of the first piece **102** (e.g., along a lower inwardly tapered periphery of the second piece **104**). The mating threaded engagement (or other attachment mechanism) can be configured with a predefined stop/lock location so that, when the first piece **102** is mechanically secured to the second piece **104**, the first electrical connector **108** aligns with the second electrical connector **106** to provide a hard-wired electrical connection between the second ECG lead **110** (proximate to the opposite end of the second piece **104**) and the ECG detection circuitry **160** within the first piece **102**). The first piece **102** may also include a first ECG lead

112, preferably on a surface of the first piece **102** so that the first ECG lead **112** contacts the skin of a user **55**. In such embodiments, the second ECG lead **110** and the first ECG lead **112** may be spaced apart from one another (yet both in contact with the user's skin and interconnected together via other components) by a separation distance of about 1 to 8 inches, and preferably about 3-5 inches in the depicted embodiment. The first piece **102** may also include a pulse oximeter sensor **113**, preferably with at least a portion on a surface of first piece **102** so that the pulse oximeter sensor **113** contacts the skin of a user **55**. Other sensors may optionally be included.

[0029] Sensor device **100** may be 1 to 8 inches long (a maximum extending from the tip of the second piece **104** to the opposite end), and is preferably 3-5 inches long in the embodiment depicted in FIGS. 2-5. The first piece **102** may have a maximum dimension (e.g., the diameter in this embodiment) that is one-half inch to two inches, and preferably about one inch in the embodiment depicted in FIGS. 2-5. The first piece **102** may weigh up to 3 or 4 ounces, is preferably less than two ounces, and weighs 0.25-1 ounces in the embodiment depicted in FIGS. 2-5. In the preferred embodiment, the length of the second piece **104** is configured such that a second ECG lead **110** on the second piece **104** may be at a predefined distance from a first ECG lead **112** on the first piece **102** such that ECG detection circuitry **160** operates effectively. The second piece **104** may weigh up to 2 or 3 ounces, and preferably less than one ounce in the embodiment depicted in FIGS. 2-5. The second piece **104** may include a flexible body **105**, which in this embodiment, comprises a flexible web of polymer material with a biocompatible adhesive layer for attachment to the skin of user **55**.

[0030] Referring now to FIGS. 6A-B, the first piece **102** of the sensor device **100** can have a relatively small disc-shaped form. Preferably, the first piece **102** has a size that is small enough to reduce the likelihood of encumbering the user **55** during his or her physical activity. Additionally, the first piece **102** has a size sufficient to house control circuitry **150**, multiple physiological sensor instruments **154**, **156**, **158**, **160**, a power source **162**, and a wireless communication device **164**.

[0031] Control circuitry **150** may include at least one processor **151** and memory **152**. Control circuitry **150** may be configured to receive data, physiological parameters, and/or work-out parameters from one or more physiological sensor instruments **154**, **156**, **158**, **160**; store data, physiological parameters, and/or work-out parameters in memory **152**; and convert data or physiological parameters from one or more physiological sensor instruments **154**, **156**, **158**, **160** into other physiological parameters or work-out parameters.

[0032] Sensor device **100** may include at least one accelerometer **156**. Accelerometer **156** may optionally detect a user's physical movements, such as whether the user has started or stopped running. Thus, a benefit of some embodiments is to detect and measure the user's physical movements.

[0033] Sensor device **100** may include a pulse oximeter **154** including a pulse oximeter sensor **113**. Pulse oximeter sensor **113** may be structurally separate but in electrical continuity with pulse oximeter **154**, or pulse oximeter sensor **113** may be integrated with pulse oximeter sensor **154**. Pulse oximeter **154** may measure both the user's heartrate or pulse, and the user's oxygen saturation. Preferably, pulse oximeter

154 utilizes an infrared light-emitting diode and measures the amount of infrared light that the user's blood absorbs. Some components or functions of pulse oximeter **154** may be located or performed in control circuitry **150** (for example, in some embodiments, the absorption data can be converted into an oxygen saturation value using the control circuitry).

[0034] During physical activity, a user's heartrate or pulse typically increases relative to the intensity of the physical activity. For example, a user's resting heartrate may be as low as 40-50 beats per minute, but as high as 180-200 beats per minute during intense physical activity. During physical activity, a user's oxygen saturation may fluctuate or decrease slightly. For example, a user's resting oxygen saturation may be approximately 98%, but may fluctuate or drop a few percent during physical activity. If oxygen saturation drops below 90%, the user may experience hypoxia. Thus, a benefit of some embodiments may be to detect a potentially dangerous drop in a user's oxygen saturation.

[0035] In some embodiments, sensor device **100** includes a temperature sensor **158** that can measure a user's body temperature, either directly or indirectly. For example, in the preferred embodiment, temperature sensor **158** includes a thermocouple, which may detect a voltage change induced by the thermoelectric effect. In other embodiments, temperature sensor **158** may include a resistance thermometer, an infrared thermometer, or a bimetallic thermometer. Temperature sensor **158** may include a temperature sensor lead capable of contacting the user's skin for, among other things, improved accuracy of temperature readings.

[0036] During and after physical activity, a user's body temperature may change. Physical activity causes a person's muscles to generate more heat than when the person is at rest. Natural bodily processes such as increased perspiration often help dissipate the extra heat generated by the muscles. Environmental conditions such as ambient temperature and humidity may affect these natural bodily processes. For example, a user that is conducting physical activity in a hot and humid environment may experience a rise in body temperature, which could lead to overheating, heat exhaustion, or dehydration. When a user engaged in physical activity for an extended period of time (e.g. more than 30 minutes), quickly stops (e.g. does not "cool down"), the user's muscles may quickly stop generating more heat, but the natural bodily processes that cool the body may not stop as quickly. This may cause post-exercise hypothermia. Thus, a benefit of some embodiments may be to detect both dangerously high and dangerously low body temperatures during or after physical activity.

[0037] In some embodiments, sensor device **100** includes an electrocardiogram (ECG) detection circuitry **160**. The sensor device **100** may include a first ECG lead **112**, which may be on the first piece **102**, and a second ECG lead **110**, which may be on the second piece **104**, to operate with ECG detection circuitry **160**. The second ECG lead **110** may be capable of being electrically connected to the first piece **102** via a connection **114** and connector **106**. Generally, ECG detection circuitry **160** operates by detecting at the skin the electrical signals that stimulate the heart. ECG detection circuitry **160** may detect, among other things, the electrical signals of the user's heart, blood pressure, and/or pulse.

[0038] During physical activity, a user's pulse typically increases, as previously discussed. During physical activity, a user's blood pressure may increase as well. For example,

a user's systolic pressure may increase as the heart works to deliver increased amounts of blood to the muscles. A user that engages in regular physical activity (e.g. at least 3 times per week for at least 30 minutes each session) may strengthen his or her heart and/or cardiovascular system, thereby lowering the user's pulse and blood pressure during successive physical-activity sessions. Thus, a benefit of some embodiments may be to track a user's pulse and blood pressure over successive physical-activity sessions. ECG detection circuitry **160** may also detect electrical signals indicative of a heart abnormality (e.g. arrhythmia). Thus, a benefit of some embodiments may be to detect heart and/or cardiovascular abnormalities.

[0039] Sensor device **100** may include a power source **162**, which may preferably be a non-rechargeable battery. For example, power source **162** may be a disc-shaped non-rechargeable battery, with an electrical potential of approximately 2-5 volts, and a size of approximately one-quarter inch to one and one-half inches in diameter. Power source **162** may also be a rechargeable power source, such as a rechargeable battery, capable of being removed from sensor device **100** for recharging. Power source **162** may also be rechargeable power source capable of being recharged without removing power source **162** from sensor device **100** or the first piece **102**.

[0040] In some embodiments, sensor device **100** may include a wireless communication device **164**, which may preferably include a Bluetooth communication device with an antenna and communication circuitry. Wireless communication device **164** may optionally include a near-field communication (NFC) device and/or a wifi communication device. Wireless communication device **164** may be capable of sending and receiving data, physiological parameters and/or work-out parameters between sensor device **100** and computing devices **200**, **300**. For example, a user **55** may conduct physical activity with computing device **200** within the range of wireless communication device **164** (e.g., going for a run while carrying a smartphone in an armband). Transmission of data, physiological parameters and/or work-out parameters may occur contemporaneously with the user's physical activity, or after the user has completed his or her physical-activity session.

[0041] Referring now to FIGS. 7A-D, in some embodiments, sensor device **100** may be configured to wirelessly communicate with computing device **200**, **300**. Optionally, computing device **200**, **300** may be a mobile computing device, such as a smartphone. Computing device **200**, **300** may include a user interface (e.g., a display screen) that enables the user to establish a wireless connection between computing device **200**, **300** and sensor device **100**, for example as shown in FIG. 7A. Computing device **200**, **300** may be configured to store data, physiological parameters and/or workout parameters. The user interface of computing device **200**, **300** may enable the user to view data, physiological parameters and/or workout parameters from a plurality of physical-activity sessions, such as workouts from previous days of the week, for example as shown in FIGS. 7B-7C. Computing device **200**, **300** may include a user interface that displays data, physiological parameters and/or workout parameters. For example, computing device **200**, **300** may display power, strain, recovery, heart rate or pulse, or temperature or body temperature, for example as shown in FIG. 7D.

[0042] Referring now to FIGS. 8-9, in other embodiments, a plurality of sensor devices **100** can wirelessly and contemporaneously communicate with a designated computing device **300**, such as the computing device of a coach, trainer, judge, or other monitor. Computing device **200**, **300** may include a user interface (e.g., a display screen) for a monitor (e.g., a coach or judge), enabling a monitor to view data, physiological parameters and/or workout parameters corresponding to each user **55**. The monitor's computing device **300** may contemporaneously display physiological or work-out parameters corresponding to the plurality of sensor devices **100**, which may be worn by a plurality of users **55** competing or participating in a workout, sport, practice, exercise, or other physical activity. Optionally, the monitor may also be a user **55** that wears one of the body-worn sensors.

What is claimed is:

1. A body-worn sensor comprising: a first piece that houses a power source, memory, a processor, a pulse oximeter, a temperature sensor, an accelerometer, ECG detection circuitry, a wireless communication device, and a first ECG lead; and a second piece mechanically and releasably attachable to the first piece and including a flexible body with a second ECG lead embedded therein for communication with the ECG detection circuitry housed within the first piece.

2. The body-worn sensor of claim 1, wherein the second piece includes a biocompatible adhesive layer along an underside of the flexible body to contact a skin surface such that the second piece is disposable and non-reusable after adhesion to a user's body.

3. The body-worn sensor of claim 2, wherein the first piece comprises an exterior housing configured to nest within a corresponding aperture defined by the second piece, the exterior housing of the first piece having an attachment mechanism to mechanically and releasably secure to the second piece, wherein the first piece is reusable with a series of second pieces having a form factor the same as said second piece.

4. The body-worn sensor of claim 3, wherein the attachment mechanism comprises a mating threaded engagement with a predefined lock location so that, when the first piece is mechanically secured to the second piece, a first electrical connector exposed along an exterior of the first piece aligns with a second electrical connector exposed along the corresponding aperture defined by the second piece to provide a hardwired electrical connection between the second ECG lead embedded within the flexible body of the second piece and the ECG detection circuitry within the housing of the first piece.

5. The body-worn sensor of claim 4, wherein the first ECG lead of the first piece extends to a first lead end at an exterior lower surface of the housing of the first piece so that the first ECG lead contacts the skin surface when the flexible body of the second piece is adhered to the skin surface, and wherein the second ECG lead extends through the flexibly body of the second piece to a second lead end at an exterior lower surface of the flexible body of the second piece such that the second lead end of the second ECG lead and the first lead end of the first ECG lead are spaced apart from one another by a separation distance of about 2.5-5 inches.

6. The body-worn sensor of claim 4, wherein the flexibly body of the second piece has an outer periphery with tear-drop shape.

7. The body-worn sensor of claim 1, wherein the second piece comprises a garment.

8. The body-worn sensor of claim 1, wherein the power source is a rechargeable battery.

9. A system for wirelessly communicating multiple physiological parameters to a computing device, comprising:

a mobile computing device having a user interface display screen and a first wireless communication device;

a physiological sensor device wearable on a user's skin, comprising:

a first piece housing a power source, memory, a processor, a pulse oximeter, a temperature sensor, an accelerometer, an ECG detection circuitry, and a second wireless communication device to communicate with the first wireless communication device of the mobile computing device; and

a second piece mechanically and releasably attachable coupled to the first piece and comprising a flexible body with an adhesive layer such that the second piece retains the first piece in a position against the user's skin when the physiological sensor device is worn on the user's skin;

wherein the physiological sensor device wirelessly communicates with the mobile computing device to transmit a set of physiological parameters to the mobile computing device, and at least one physiological parameter is displayed on the user interface display of the mobile computing device.

10. The system of claim 9, wherein the physiological sensor device further comprises a first ECG lead and a second ECG lead.

11. The system of claim 10, wherein the second piece of the physiological sensor device is disposable.

12. The system of claim 9, further comprising a second physiological sensor device, and wherein the mobile computing device is a monitor's computing device that contemporaneously receives physiological parameters from first and second physiological sensor devices.

13. A process for using at least one body-worn physiological sensor device comprising:

wirelessly communicating at least one physiological parameter from a physiological sensor device to a computing device comprising a first wireless communication device, wherein the physiological sensor device is worn on a user's skin and further includes:

a first piece housing a power source, memory, a processor, a pulse oximeter, a temperature sensor, an accelerometer, an ECG detection circuitry, and a second wireless communication device to communicate with the first wireless communication device of the computing device; and

a second piece mechanically and releasably attachable coupled to the first piece and comprising a flexible body with an adhesive layer such that the second piece retains the first piece in a position against the user's skin when the physiological sensor device is worn on the user's skin;

displaying the at least one physiological parameter on a user interface display of the computing device; and

displaying at least one work-out parameter on the user interface display of the computing device.

14. The process of claim 13, wherein said at least one work-out parameter is a calculated value based at least in part on a physiological parameter detected by the physiological sensor device.

15. The process of claim 14, wherein the first ECG lead of the first piece extends to a first lead end at an exterior lower surface of the first piece so that the first ECG lead contacts the user's skin when the flexible body of the second piece is adhered to the user's skin, and wherein the second ECG extends through the flexible body of the second piece to a second lead end at an exterior lower surface of the flexible body of the second piece such that the second lead end of the second ECG lead and the first lead end of the first ECG lead are spaced apart from one another by a separation distance of about 2.5-5 inches.

16. The process of claim 15, wherein the flexibly body of the second piece has an outer periphery with a tear-drop shape.

17. The process of claim 13, wherein the computing device comprises a mobile computing device that wirelessly communicates with the physiological sensor device via a short-range wireless communication protocol.

18. A process for contemporaneously using a set of physiological sensor devices, comprising:

contemporaneously and wirelessly communicating a plurality of physiological parameters from a set of physiological sensor devices to a computing device while each of the physiological sensor devices is worn in contact with a skin surface of a respective user;

correlating each physiological parameter to each physiological sensor device;

contemporaneously displaying the physiological parameters on a user interface display of a computing device; and

contemporaneously displaying a plurality of work-out parameters on the user interface display of the computing device.

19. The process of claim 18, wherein each of the physiological sensor devices includes:

a first piece housing a power source, memory, a processor, a pulse oximeter, a temperature sensor, an accelerometer, an ECG detection circuitry, and a wireless communication device to communicate with the computing device; and

a second piece mechanically and releasably attachable coupled to the first piece and comprising a tear-drop shaped, flexible body with an adhesive layer such that the second piece retains the first piece in a position against the user's skin when the physiological sensor device is worn on the user's skin.

20. The process of claim 19, wherein the computing device comprises a mobile computing device that wirelessly communicates with the set of physiological sensor devices via a short-range wireless communication protocol.

* * * * *

专利名称(译)	身体佩戴的生物识别传感器		
公开(公告)号	US20180184914A1	公开(公告)日	2018-07-05
申请号	US15/397525	申请日	2017-01-03
[标]发明人	GOERING JARED STEINERT SPENCERT		
发明人	GOERING, JARED STEINERT, SPENCERT		
IPC分类号	A61B5/0205 A41D1/00 A61B5/1455 A61B5/01 A61B5/11 A61B5/0408 A61B5/00		
CPC分类号	A61B5/02055 A41D1/002 A61B5/14552 A61B5/01 A61B2560/0214 A61B5/04085 A61B5/0022 A61B5/6832 A61B5/1118 A61B5/024 A61B5/0402 A61B5/6802 A61B2505/09 A61B2562/0219 G16H40/67		
其他公开文献	US10646120		
外部链接	Espacenet USPTO		

摘要(译)

用于在身体活动之前，期间和/或之后跟踪或查看用户的生理参数的系统和方法。在一些版本中，传感器设备可以佩戴在用户的身体上并且被配置为检测多个生理参数并且与移动计算设备无线通信。可选地，检测到的生理参数可以用于确定所选择的一组锻炼参数，其可以在用户的锻炼/活动期间或锻炼期之后同时显示在移动计算设备上。在一些实施方式中，多个用户中的每一个可以佩戴相应的身体佩戴的传感器设备，并且所有传感器设备可以与指定的移动计算设备无线通信，以共同（并且同时）监视所有生理参数的集合。在相同的锻炼，练习或其他活动中的用户。

