



US008840564B2

(12) **United States Patent**
Pinhas et al.

(10) **Patent No.:** **US 8,840,564 B2**
(45) **Date of Patent:** **Sep. 23, 2014**

(54) **MONITORING A CONDITION OF A SUBJECT**

(71) Applicant: **EarlySense Ltd.**, Ramat Gan (IL)

(72) Inventors: **Itzhak Pinhas**, Holon (IL); **Avner Halperin**, Ramat Gan (IL); **Daniel H. Lange**, Kfar Vradim (IL)

(73) Assignee: **Early Sense Ltd.**, Ramat Gan (IL)

(*) Notice: Subject to any disclaimer, the term of this patent is extended or adjusted under 35 U.S.C. 154(b) by 0 days.

(21) Appl. No.: **14/150,115**

(22) Filed: **Jan. 8, 2014**

(65) **Prior Publication Data**

US 2014/0171816 A1 Jun. 19, 2014

Related U.S. Application Data

(63) Continuation of application No. 13/921,915, filed on Jun. 19, 2013, now Pat. No. 8,679,030, which is a continuation of application No. 13/107,772, filed on May 13, 2011, now Pat. No. 8,491,492, which is a continuation-in-part of application No. 11/782,750, filed on Jul. 25, 2007, now Pat. No. 8,403,865, and a continuation-in-part of application No. 11/552,872, filed on Oct. 25, 2006, now abandoned, application No. 14/150,115, which is a continuation-in-part of application No. 13/863,293, filed on Apr. 15, 2013, which is a continuation of application No. 11/552,872, filed on Oct. 25, 2006, now abandoned.

(60) Provisional application No. 60/731,934, filed on Nov. 1, 2005, provisional application No. 60/784,799, filed on Mar. 23, 2006, provisional application No. 60/843,672, filed on Sep. 12, 2006.

(51) **Int. Cl.**

A61B 5/08 (2006.01)
A61B 5/00 (2006.01)
A61B 5/113 (2006.01)
A61B 5/0205 (2006.01)

(52) **U.S. Cl.**

CPC **A61B 5/0205** (2013.01); **A61B 5/7282** (2013.01); **A61B 5/113** (2013.01); **A61B 5/0816** (2013.01)

USPC **600/529**; 600/534

(58) **Field of Classification Search**

USPC 600/529, 534
See application file for complete search history.

(56) **References Cited**

U.S. PATENT DOCUMENTS

3,890,958 A 6/1975 Fister
4,122,838 A 10/1978 Leonard

(Continued)

FOREIGN PATENT DOCUMENTS

EP 0853918 7/1998
EP 0860803 8/1998

(Continued)

OTHER PUBLICATIONS

"Breathing easier with asthma", pp. 1-46, http://www.ihc.com/xp/ihc/documents/clinical1/101/3/1/asthma_breathe.pdf.

(Continued)

Primary Examiner — Nicole F Lavert

(74) *Attorney, Agent, or Firm* — Roach Brown McCarthy & Gruber, P.C.; Kevin D. McCarthy

(57) **ABSTRACT**

Apparatus and methods are described, including a method for monitoring an onset of a respiratory episode in a subject. A plurality of respirations of the subject are sensed without contacting the subject, and a plurality of respiration signals corresponding to the plurality of respirations are generated. The plurality of respiration signals are combined to provide a characteristic respiration parameter of the subject. The onset of the respiratory episode is predicted from the characteristic respiration parameter. Other applications are also described.

7 Claims, 7 Drawing Sheets

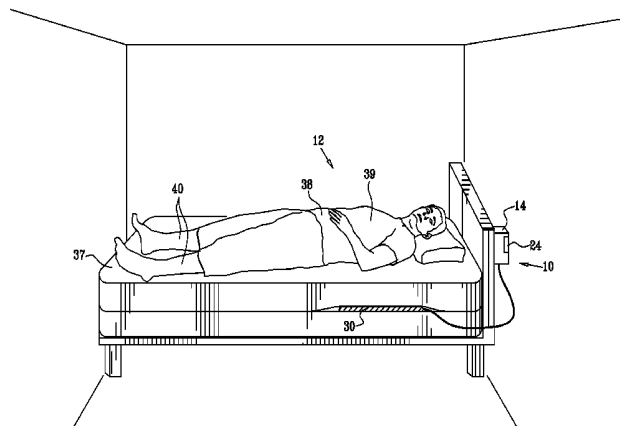

(56)

References Cited

U.S. PATENT DOCUMENTS

4,301,879	A	11/1981	Dubow	6,368,287	B1	4/2002	Hadas
4,338,950	A	7/1982	Barlow, Jr.	6,375,621	B1	4/2002	Sullivan
4,494,553	A	1/1985	Sciarra	6,375,623	B1	4/2002	Gavriely
4,657,025	A	4/1987	Orlando	6,383,142	B1	5/2002	Gavriely
4,657,026	A	4/1987	Tagg	6,402,691	B1	6/2002	Peddicord
4,686,999	A	8/1987	Snyder	6,409,661	B1	6/2002	Murphy
4,738,264	A	4/1988	Orlando	6,436,057	B1	8/2002	Goldsmith
4,757,825	A	7/1988	Diamond	6,450,957	B1	9/2002	Yoshimi
4,817,610	A	4/1989	Lee	6,454,719	B1	9/2002	Greenhut
4,832,038	A	5/1989	Arai	6,468,234	B1	10/2002	Van der Loos
4,926,866	A	5/1990	Lee	6,485,441	B2	11/2002	Woodward
5,002,060	A	3/1991	Nedivi	6,498,652	B1	12/2002	Varshneya
5,010,772	A	4/1991	Bourland	6,512,949	B1	1/2003	Combs
5,025,791	A	6/1991	Niwa	6,517,497	B2	2/2003	Rymut
5,076,281	A	12/1991	Gavish	6,527,729	B1	3/2003	Turcott
5,107,845	A	4/1992	Guern	6,544,173	B2	4/2003	West
5,111,826	A	5/1992	Nasiff	6,544,174	B2	4/2003	West
5,137,033	A	8/1992	Norton	6,547,743	B2	4/2003	Brydon
5,235,989	A	8/1993	Zomer	6,551,252	B2	4/2003	Sackner
5,253,656	A	10/1993	Rincoe	6,561,978	B1	5/2003	Conn
5,276,432	A	1/1994	Travis	6,579,232	B2	6/2003	Sakamaki
5,309,921	A	5/1994	Kisner	6,585,645	B2	7/2003	Hutchinson
5,309,922	A	5/1994	Schechter	6,589,188	B1	7/2003	Street
5,319,363	A	6/1994	Welch	6,599,251	B2	7/2003	Chen
5,368,026	A	11/1994	Swedlow	6,600,949	B1	7/2003	Turcott
5,393,935	A	2/1995	Hasty	6,616,606	B1	9/2003	Petersen
5,448,996	A	9/1995	Bellin	6,630,568	B1	10/2003	Johnson
5,479,939	A	1/1996	Ogino	6,631,281	B1	10/2003	Kastle
5,515,865	A	5/1996	Scanlon	6,641,542	B2	11/2003	Cho
5,520,176	A	5/1996	Cohen	6,646,556	B1	11/2003	Smith
5,522,382	A	6/1996	Sullivan	6,662,032	B1	12/2003	Gavish
5,540,734	A	7/1996	Zabara	6,666,830	B1	12/2003	Lehrman
5,590,650	A	1/1997	Genova	6,719,708	B1	4/2004	Jansen
5,620,003	A	4/1997	Sepponen	6,725,074	B1	4/2004	Kastle
5,662,106	A	9/1997	Swedlow	6,731,311	B2	5/2004	Bufe
5,684,460	A	11/1997	Scanlon	6,745,060	B2	6/2004	Diab
5,687,734	A	11/1997	Dempsey	6,751,498	B1	6/2004	Greenberg
5,699,038	A	12/1997	Ulrich	6,752,766	B2	6/2004	Kowallik
5,730,140	A	3/1998	Fitch	6,754,516	B2	6/2004	Mannheimer
5,738,102	A	4/1998	Lemelson	6,790,183	B2	9/2004	Murphy
5,743,263	A	4/1998	Baker, Jr.	6,821,258	B2	11/2004	Reed
5,797,852	A	8/1998	Karakasoglu	6,822,564	B2	11/2004	Al-Ali
5,800,337	A	9/1998	Gavish	6,827,670	B1	12/2004	Stark
5,800,360	A	9/1998	Kisner	6,830,548	B2	12/2004	Bonnet
5,853,005	A	12/1998	Scanlon	6,840,907	B1	1/2005	Brydon
5,879,313	A	3/1999	Raviv	6,856,141	B2	2/2005	Ariav
5,902,250	A	5/1999	Verrier	6,878,121	B2	4/2005	Krausman
5,944,680	A	8/1999	Christopherson	6,893,404	B2	5/2005	Ragnarsdottir
5,957,861	A	9/1999	Combs	6,955,647	B2	10/2005	Rice
5,964,720	A	10/1999	Pelz	6,980,679	B2	12/2005	Jeung
5,989,193	A	11/1999	Sullivan	6,984,207	B1	1/2006	Sullivan
6,014,346	A	1/2000	Malone	6,984,993	B2	1/2006	Ariav
6,015,388	A	1/2000	Sackner	6,988,989	B2	1/2006	Weiner
6,033,370	A	3/2000	Reinbold	7,022,072	B2	4/2006	Fox
6,036,660	A	3/2000	Toms	7,025,729	B2	4/2006	de Chazal
6,047,203	A	4/2000	Sackner	7,077,810	B2	7/2006	Lange
6,062,216	A	5/2000	Corn	7,283,161	B2	10/2007	Someya
6,064,910	A	5/2000	Andersson	7,304,580	B2	12/2007	Sullivan
6,080,106	A	6/2000	Lloyd	7,314,451	B2	1/2008	Halperin
6,090,037	A	7/2000	Gavish	7,390,299	B2	6/2008	Weiner
6,093,146	A	7/2000	Filangeri	7,396,331	B2	7/2008	Mack
6,104,949	A	8/2000	Pitts Crick	7,396,333	B2	7/2008	Stahmann
6,126,595	A	10/2000	Amano	7,415,297	B2	8/2008	Al-Ali
6,134,970	A	10/2000	Kumakawa	7,428,468	B2	9/2008	Takemura
6,135,970	A	10/2000	Kadhiresan	7,431,700	B2	10/2008	Aoki
6,157,850	A	12/2000	Diab	7,433,827	B2	10/2008	Rosenfeld
6,168,568	B1	1/2001	Gavriely	7,439,856	B2	10/2008	Weiner
6,198,394	B1	3/2001	Jacobsen	7,454,359	B2	11/2008	Rosenfeld
6,223,064	B1	4/2001	Lynn	7,508,307	B2	3/2009	Albert
6,239,706	B1	5/2001	Yoshiike	7,572,225	B2	8/2009	Stahmann
6,259,355	B1	7/2001	Chaco	7,610,094	B2	10/2009	Stahmann
6,261,238	B1	7/2001	Gavriely	7,629,890	B2	12/2009	Sullivan
6,290,654	B1	9/2001	Karakasoglu	7,666,151	B2	2/2010	Sullivan
6,325,761	B1	12/2001	Jay	7,689,440	B2	3/2010	Brown
6,352,517	B1	3/2002	Flock	7,704,215	B2	4/2010	Lewicke
				7,778,851	B2	8/2010	Schoenberg
				7,860,583	B2	12/2010	Condurso
				7,880,606	B2	2/2011	Al-Ali
				7,896,813	B2	3/2011	Sowelam

(56)

References Cited

U.S. PATENT DOCUMENTS

7,938,782 B2 5/2011 Stahmann
 7,952,475 B2 5/2011 Ivanov
 7,959,574 B2 6/2011 Bardy
 8,016,480 B2 9/2011 Lozinski
 8,376,954 B2 2/2013 Lange
 8,403,865 B2 3/2013 Halperin
 2001/0005773 A1 6/2001 Larsen
 2002/0058155 A1 5/2002 Guofang
 2002/0077554 A1 6/2002 Schwartz
 2002/0082486 A1 6/2002 Lavery
 2002/0086870 A1 7/2002 Radulovacki
 2002/0097155 A1 7/2002 Cassel
 2002/0099303 A1 7/2002 Bardy
 2002/0106709 A1 8/2002 Potts
 2002/0150957 A1 10/2002 Slotman
 2002/0196148 A1 12/2002 Nunome
 2003/0004403 A1 1/2003 Drinan
 2003/0004423 A1 1/2003 Lavie
 2003/0018276 A1 1/2003 Mansy
 2003/0045806 A1 3/2003 Brydon
 2003/0125612 A1 7/2003 Fox
 2003/0135127 A1 7/2003 Sackner
 2003/0139678 A1 7/2003 Hoiium
 2003/0153831 A1 8/2003 Zumeris
 2003/0199945 A1 10/2003 Ciulla
 2004/0010202 A1 1/2004 Nakatani
 2004/0073098 A1 4/2004 Geva
 2004/0082874 A1 4/2004 Aoki
 2004/0111040 A1 6/2004 Ni
 2004/0111045 A1 6/2004 Sullivan
 2004/0116784 A1 6/2004 Gavish
 2004/0133079 A1 7/2004 Mazar
 2004/0166541 A1 8/2004 Guo
 2004/0210155 A1 10/2004 Takemura
 2004/0225226 A1 11/2004 Lehrman
 2004/0230105 A1 11/2004 Geva
 2005/0027216 A1 2/2005 Guillemaud
 2005/0043644 A1 2/2005 Stahmann
 2005/0061315 A1 3/2005 Lee
 2005/0074361 A1 4/2005 Tanoshima
 2005/0080349 A1 4/2005 Okada
 2005/0085734 A1 4/2005 Tehrani
 2005/0085866 A1 4/2005 Tehrani
 2005/0096557 A1 5/2005 Vosburgh
 2005/0102165 A1 5/2005 Oshita
 2005/0119586 A1 6/2005 Coyle
 2005/0124864 A1 6/2005 Mack
 2005/0165284 A1 7/2005 Gefen
 2005/0168341 A1 8/2005 Reeder
 2005/0192508 A1 9/2005 Lange
 2005/0201970 A1 9/2005 Hu
 2005/0240091 A1 10/2005 Lynn
 2006/0020295 A1 1/2006 Brockway
 2006/0028350 A1 2/2006 Bhai
 2006/0063982 A1 3/2006 Sullivan
 2006/0084848 A1 4/2006 Mitchnick
 2006/0089856 A1 4/2006 Kadhiresan
 2006/0129047 A1 6/2006 Ruotoistenmaki
 2006/0152378 A1 7/2006 Lokhorst
 2006/0155167 A1 7/2006 Elliott
 2006/0195025 A1 8/2006 Ali
 2006/0220885 A1 10/2006 Bock
 2006/0258952 A1 11/2006 Stahmann
 2007/0024451 A1 2/2007 Albert
 2007/0032733 A1 2/2007 Burton
 2007/0118054 A1 5/2007 Pinhas
 2007/0139678 A1 6/2007 Horita
 2007/0156031 A1 7/2007 Sullivan
 2007/0177785 A1 8/2007 Raffy
 2007/0249952 A1 10/2007 Rubin
 2007/0257564 A1 11/2007 Kitade
 2007/0276202 A1 11/2007 Raisanen
 2008/0004904 A1 1/2008 Tran
 2008/0005838 A1 1/2008 Wan Fong
 2008/0033304 A1 2/2008 Dalal

2008/0114260 A1 5/2008 Lange
 2008/0275349 A1 11/2008 Halperin
 2009/0164239 A1 6/2009 Hayter
 2009/0299229 A1 12/2009 Johnson
 2010/0217618 A1 8/2010 Piccirillo
 2010/0234705 A1 9/2010 Lynn
 2011/0046498 A1 2/2011 Klap
 2011/0112442 A1 5/2011 Meger
 2011/0282216 A1 11/2011 Shinar
 2012/0253142 A1 10/2012 Meger
 2013/0174345 A1 7/2013 Leu
 2014/0012099 A1 1/2014 Halperin
 2014/0046209 A1 2/2014 Klap

FOREIGN PATENT DOCUMENTS

GB 2329966 4/1999
 JP 5323635 12/1993
 JP 08-080285 3/1996
 JP 08-225210 9/1996
 JP 2001-037739 2/2001
 JP 2001-145605 5/2001
 JP 2001-327549 11/2001
 JP 2002-336207 11/2002
 JP 2004-049388 2/2004
 JP 2005-021450 1/2005
 JP 2005-095307 4/2005
 JP 2005-143661 6/2005
 JP 2005-160876 6/2005
 JP 2005-237479 9/2005
 JP 2005-279113 10/2005
 WO 86/05965 10/1986
 WO 96/08197 3/1996
 WO 97/40748 11/1997
 WO 99/04691 2/1999
 WO 99/32537 7/1999
 WO 01/73718 10/2001
 WO 01/80727 11/2001
 WO 03/013355 2/2003
 WO 03/057025 7/2003
 WO 2004/006768 1/2004
 WO 2004/091378 10/2004
 WO 2004/114193 12/2004
 WO 2005/028029 3/2005
 WO 2005/037077 4/2005
 WO 2005/037366 4/2005
 WO 2005/055824 6/2005
 WO 2005/074361 8/2005
 WO 2006/008743 1/2006
 WO 2006/054306 5/2006
 WO 2006/082589 8/2006
 WO 2006/137067 12/2006
 WO 2007/052108 5/2007
 WO 2007/081629 7/2007
 WO 2008/135985 11/2008
 WO 2009/138976 11/2009
 WO 2012/077113 6/2012

OTHER PUBLICATIONS

"British guidelines on management of asthma: a national clinical guideline", British Thoracic Society, Scottish Intercollegiate Guidelines Network, Revised edition, Apr. 2004, pp. 1-92.
 "Does my child have asthma?" Solano Asthma Coalition, American Lung Association of the East Bay (http://www.alaebay.org/misc_pdf/solano_asthma_coalition_child_asthma.pdf).
 "Managing asthma", http://kidshealth.org/pageManager.jsp?dn=KidsHealth&lic=1&ps=107&cat_id=143&article_set=2.
 "Medical Mutual clinical practice guidelines for asthma: 2004," Medical Mutual (Cleveland, OH), (<http://www.medmutual.com/provider/pdf/resources/asthma4.pdf>).
 "Non-invasive fiber-optic sensor technology for monitoring sleep apnea and SIDS", <http://www.kidsource.com/products/fiber.optic.Sids.html>.
 "Peak flow learning center", <http://www.njc.org/disease-info/diseases/asthma/living/tools/peak/index/asp>.
 "Signs and symptoms of asthma", <http://www.indianchestociety.org/symptomsofasthma.htm>.

(56)

References Cited

OTHER PUBLICATIONS

- Alihanka, J. et al., "A new method for long-term monitoring ballistocardiogram, heart rate, and respiration", *Am J Physiol Regul Integ Comp Physiol* 1981; 240: 384-92.
- Alihanka, J. et al., "A static charge sensitive bed. A new method for recording body movement during sleep", *Electroencephalography and Clinical Neurophysiology* 1979; 46(6): 731-4.
- Ancoli-Israel S. et al., (2003) The role of actigraphy in the study of sleep and circadian rhythms. *Sleep*. 26(3):342-92.
- Baren, Jill M. et al., "Current Concepts in the ED treatment of pediatric Asthma", *Respiratory Medicine Consensus Reports* (Thomson American Health Consultants, Dec. 28, 2003), pp. 1-12.
- Bentur, L. et al., "Wheeze monitoring in children for assessment of nocturnal asthma and response to therapy", *Eur respire J* 2003; 21: 621-6.
- Bilmes et al., (1998) a gentle tutorial of the EM algorithm and its application to parameter estimation for gaussian mixture and hidden markov models. *International Computer Science Institut*, pp. 1-13.
- Brenner, Barry E. et al., "The clinical presentation of acute asthma in adults and children", In Brenner, BE, ed. *Emergency Asthma* (New York: Marcel Dekker 1994; pp. 201-232).
- Butter CD. et al., (1978) Fiber optics strain gauge. *Appl Opt.* 17(18): 2867-9.
- Chaboyer W et al., (2008) Predictors of adverse events in patients after discharge from the intensive care unit. *Am J Crit Care*. 17:255-63.
- Chan et al., Prosafe a multisensory remote monitoring system for the elderly or the handicapped, *Independent Living for Persons with Disabilities and Elderly People: ICOST, 2003 1st International Conference on Smart Homes and Health Telematics*.
- Chang, A.B. et al., "Cough, airway inflammation, and mild asthma exacerbation", *Archives of disease in childhood* 2002; 86:270-5.
- Delmore G. et al., (1977) The role of augmented breaths (sighs) in bronchial asthma attacks. *Pflugers Arch*. 372(1):1-6.
- Dempster AP. et al., (1977) Maximum likelihood from incomplete data via the Em algorithm. *Journal of the Royal statistical Society* 39(1):1-38.
- E. Campo, M. Chan, Detecting abnormal behaviour by real-time monitoring of patients, *AAAI Technical Report WS-02-02*. Compilation copyright © 2002.
- Fieselmann JF et al., (1993) Respiratory rate predicts cardiopulmonary arrest for internal medicine inpatients. *J Gen Intern Med* 8(7):354-60.
- Fitzpatrick MF. et al., (1991) Morbidity in nocturnal asthma: sleep quality and daytime cognitive performance. *Thorax*. 46(8):569-73.
- Fitzpatrick, MF. et al., (1993) "Snoring, asthma and sleep disturbances in Britain: a community based survey", *ERS Journal Ltd.*, pp. 531-5..25
- Hark et al., (2005) Spontaneous sigh rates during sedentary activity: watching television vs reading. *Ann Allergy Asthma Immunol*. 94(2):247-50.
- Hogan J., (2006) Why don't nurses monitor the respiratory rates of patients? *Br J Nurs* 15(9):489-92.
- Hori et al., (2001) Proposed supplements and amendments to 'A Manual of Standardized Terminology, Techniques and Scoring System for Sleep Stages of Human Subjects', the Rechtschaffen & Kales (1968) standard. *Psychiatry Clin Neurosci*. 55(3):305-10.
- Hsu, J.Y. et al., "Coughing frequency in patients with persistent cough; Assessment using a 24 hour ambulatory recorder", *Eur Respir J* 1994; 7: 1246-53.
- Hudgel et al., (1984) Mechanics of the respiratory system and breathing pattern during sleep in normal humans. *J Appl Physiol*. 56(1): 133-7.
- Jobanputra et al., (1991) Management of acute asthma attacks in general practice. *Br J Gen Pract*. Oct. 1991;41 (351):410-3.
- Kandtelhardt, J.W., T. Penzel, S. Rostig, H. F. Becker, S. Halvin, and A. Bunde, Breathing during REM and non-REM sleep: correlated versus uncorrelated behavior, *25 Physica. A.*, vol. 319, pp. 447-457, 2003.
- Kap-Ho Seo et al., "Bed-type robotic system for the bedridden", *advanced Intelligent Mechatronics, Proceedings, 2005 IEEE/ASME International Conference on Monterey, CA Jul. 24-28, 2005*. Piscataway, NK, USA pp. 1170-5.
- Kapsali et al., (2000) Potent bronchoprotective effect of deep inspiration and its absence in asthma. *J Appl Physiol*. 89 (2):711-20.
- Katz et al., (1986) Detection of preterm labor by ambulatory monitoring of uterine activity: a preliminary report. *Obstet Gynecol*. Dec. 1986;68(6): 773-8.
- Korpas, J. et al., "Analysis of the cough sound: an overview", *Pulmonary Pharmacology* 1996; 9: 261-8.
- Li, Q. and A. Barron, "Mixture density estimation," *Advances in neural information processing systems*, vol. 12, pp. 279-285, MIT press, 2000.
- Lim TO. et al., (1992) Morbidity associated with asthma and audit of asthma treatment in out-patient clinics. *Singapore Med J*. 33(2):174-6.
- Mack, David et al., "Non-invasive analysis of physiological signals: NAPS: A low cost, passive monitoring for sleep quality and related applications", *University of Virginia Health System*. pp. 1-9.
- Madge PJ et al., (1995) Home nebuliser use in children with asthma in two Scottish Health Board Areas. *Scott Med J*. 40(5):141-3.
- Mintzer, Rich., "What the teacher should know about asthma attacks", http://www.familyeducation.com/article/print10,1303,65-415,00.html?obj_gra.
- O'Connor CJ et al., "Identification of endotracheal tube malpositions using computerized analysis of breath sounds via electronic stethoscopes," *Anesth Analg* 2005;101:735-9.
- Oppenheim, AN., and R.W. Schafer, *Discrete-Time Signal Processing*, Prentice Hall, 1989, pp. 311-312.
- Pirriila, P. et al., "Objective assessment of cough", *Eur respire J* 1995; 8: 1949-56.
- Plaut, Thomas F., "Tracking and treating asthma in young children", *J Respir Dis Pediatrician* 2003; 5(2): 67-72.
- Pomeranz et al., (1985) Assessment of autonomic function in humans by heart rate spectral analysis. *Am J Physiol* 248(1 Pt 2): H151-3.
- Poteet, Jackie, "Asthma". <http://www.nku.edu/~rad350/asthmajp.html>.
- Salmi et al., (1986) "Automatic analysis of sleep records with static charge sensitive bed", *Electroencephalography and Clinical Neurophysiology*, pp. 84-7.
- Salmi, Tapani et al., "Long-term recording and automatic analysis of cough using filtered acoustic signals and movements on static charge sensitive bed", *Chest* 1988; 94: 970-5.
- Schwartz, (1978) Estimating the dimension of a model. *The Annals of Statistics* 6(2):461-4.
- Shinar Z. et al., (2001) Automatic detection of flow-wave-sleep using heart rate variability. *Computers in cardiology* 28:593-6.
- Shochat, Michael et al., "PedemaTOR: Innovative method for detecting pulmonary edema at the pre-clinical stage", http://www.isrased.info/rsmn_rabinovich/pedemator.htm.
- Sorvoja, H. and Myllyla, R., "Noninvasive blood pressure measurement methods," *Molecular and Quantum Acoustics*. vol. 27, 2006.
- Staderini, Enrico M., (2002) *UWB Radars in Medicine*, *IEEE Aerospace and Electronic Systems Magazine*, 17(1):13-18.
- Stegmaier-Stracca, Peter A. et al., Cough detection using fuzzy classification, *Proceeding of the 1995 ACM Symposium on Applied Computing*, Nashville, TN: 440-4.
- Tamura T. et al., "A system for monitoring temperature distribution in bed and its application to the assessment of body movement", *Physiological Measurement*, Institute of Physics Publishing, Bristol, GB 1993; 14(1): 33-41.
- Thorpe C.W. et al., (1992) "Towards a quantitative description of asthmatic cough sounds", *Eur Respir J* 5(6):685-92.
- Van Der Loos, H.F. Michiel et al., "Unobstrusive vital signs monitoring from a multisensory bed sheet", *RESNA 2001*, Reno, NV, Jun. 22-26, 2001, pp. 218-20.
- Van Der Loos, H.F.M. et al., "Development of sensate and robotic bed technologies for vital signs monitoring and sleep quality improvement", *Abstract, Autonomous Robots*, 2003;15(1) <http://www.ingenta.com/isi/searching/Expand/ingenta?pub=infobike:/klu/auro/2003/00000015/00000001/05126829>.

(56)

References Cited

OTHER PUBLICATIONS

Van Hirtum A. et al., (2002) Autoregressive acoustical modeling of free field cough sound, Proc Int Conference on Acoustics, Speech and Signal Processing, Volume 1, pp. 493-496, Orlando, USA.
Waris, M. et al., "A new method for automatic wheeze detection", Technology and Health Care 1998; 6:33-40.
Watanabe et al., (2004) "Noncontact method for sleep stage estimation", IEEE transactions on Biomedical Engineering 10(51):1735-48.

Whitney, C.W., Gottlieb DJ, Redline S, Norman RG, Dodge RR, Shahar E, Surovec S and Nieto FJ, "Reliability of scoring respiratory disturbance indices and sleep staging," Sleep, Nov. 2, 1998; 21(7): 749-757.

Yien HW et al., (1997) Spectral analysis of systemic arterial pressure and heart rate signals as a prognostic tool for the prediction of patient outcome in the intensive care unit. Crit Care Med. 25(2):258-66.

Yongjoon et al., (2005) "Air matters sensor system with balancing tube for unconstrained measurement of respiration and heart beat movements", Physiol Meas, pp. 413-22.

FIG. 1

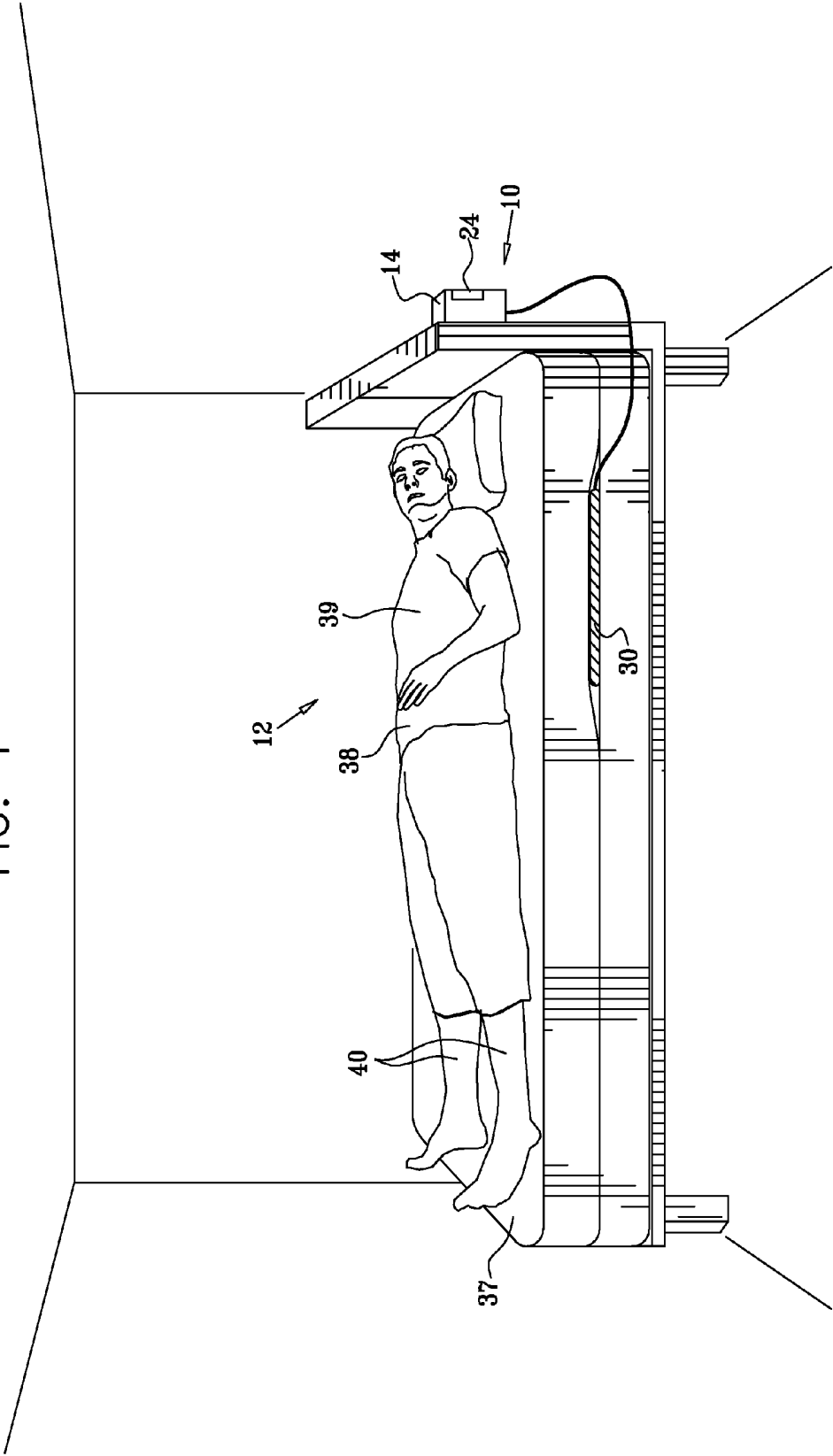

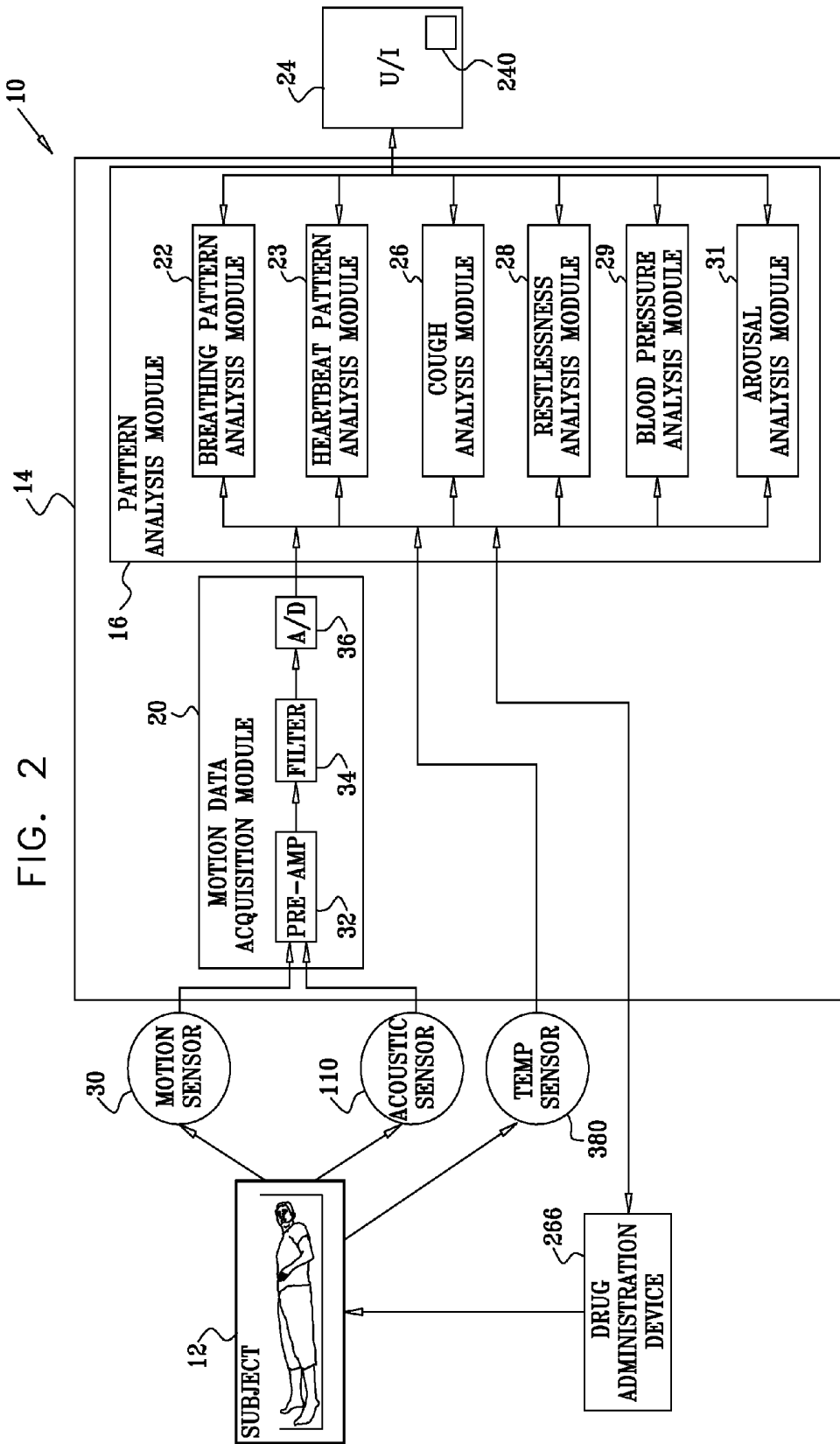

FIG. 3A

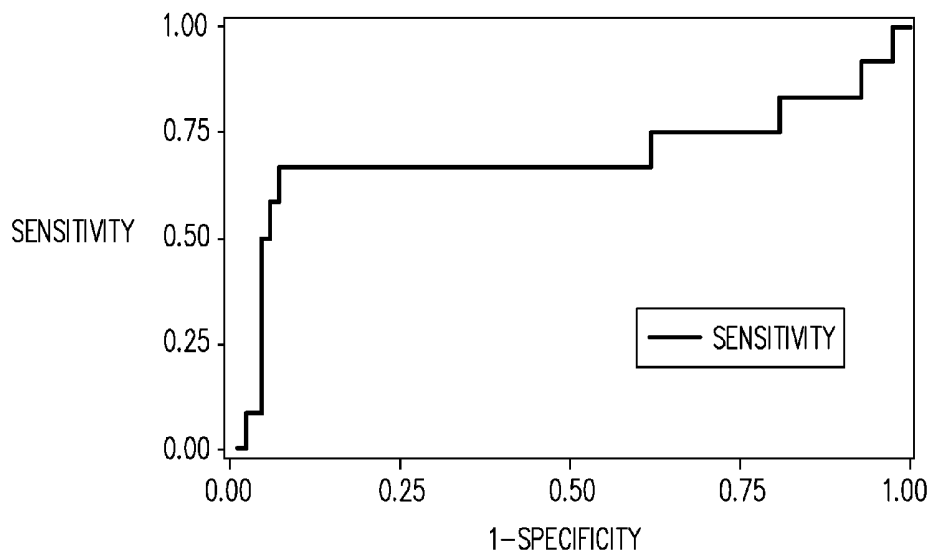

FIG. 3B

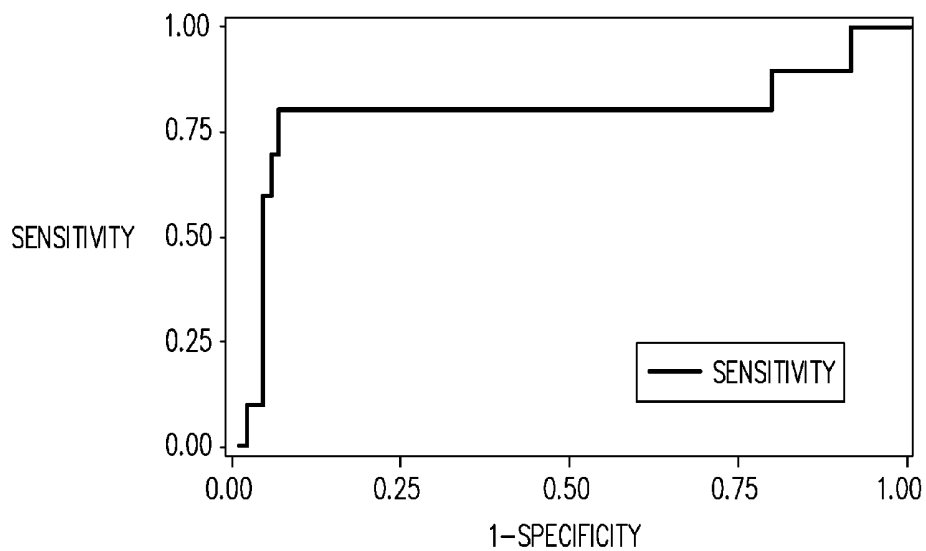

FIG. 3C

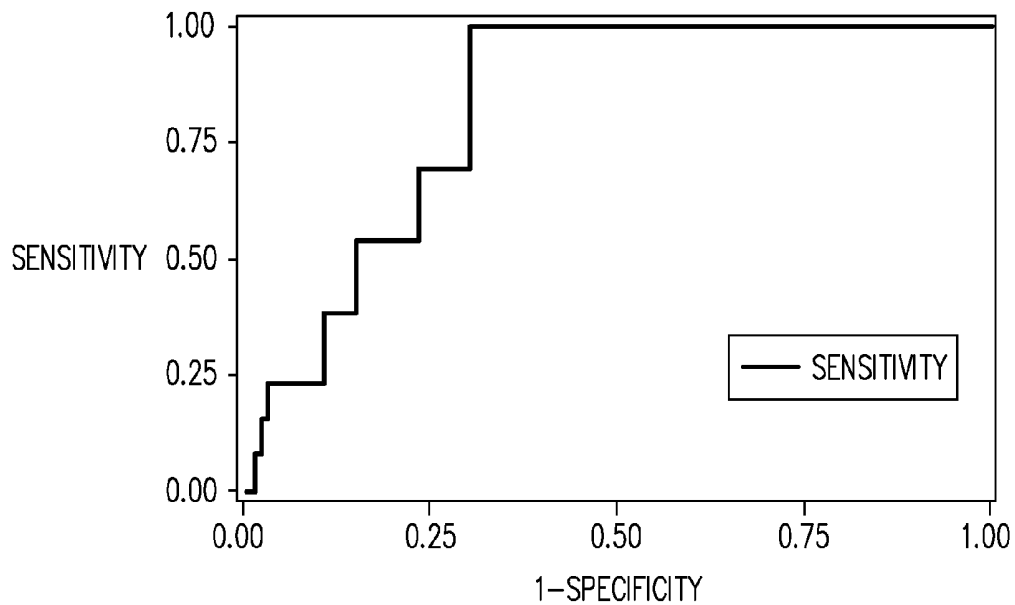
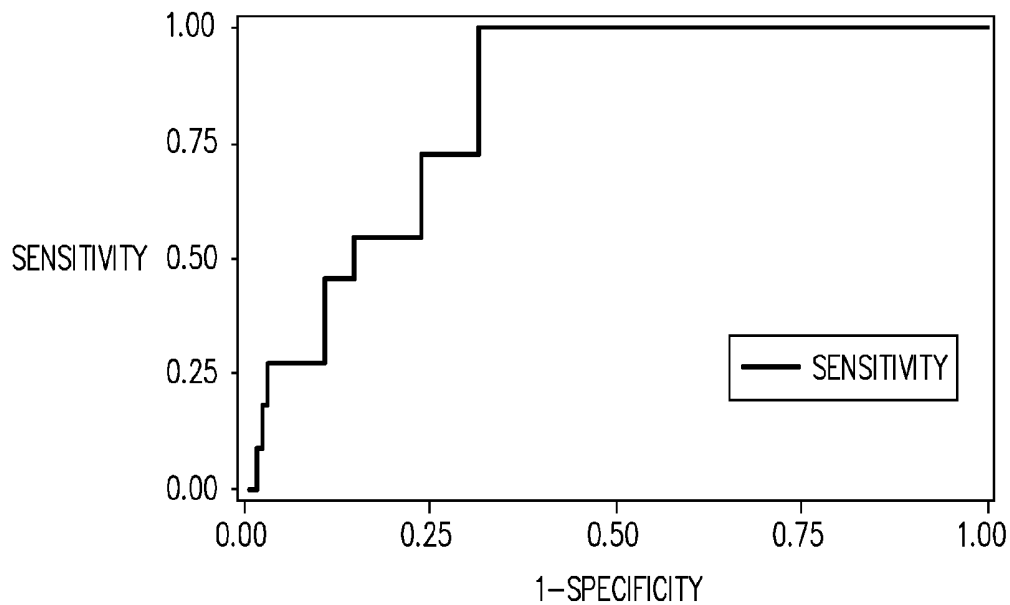

FIG. 3D



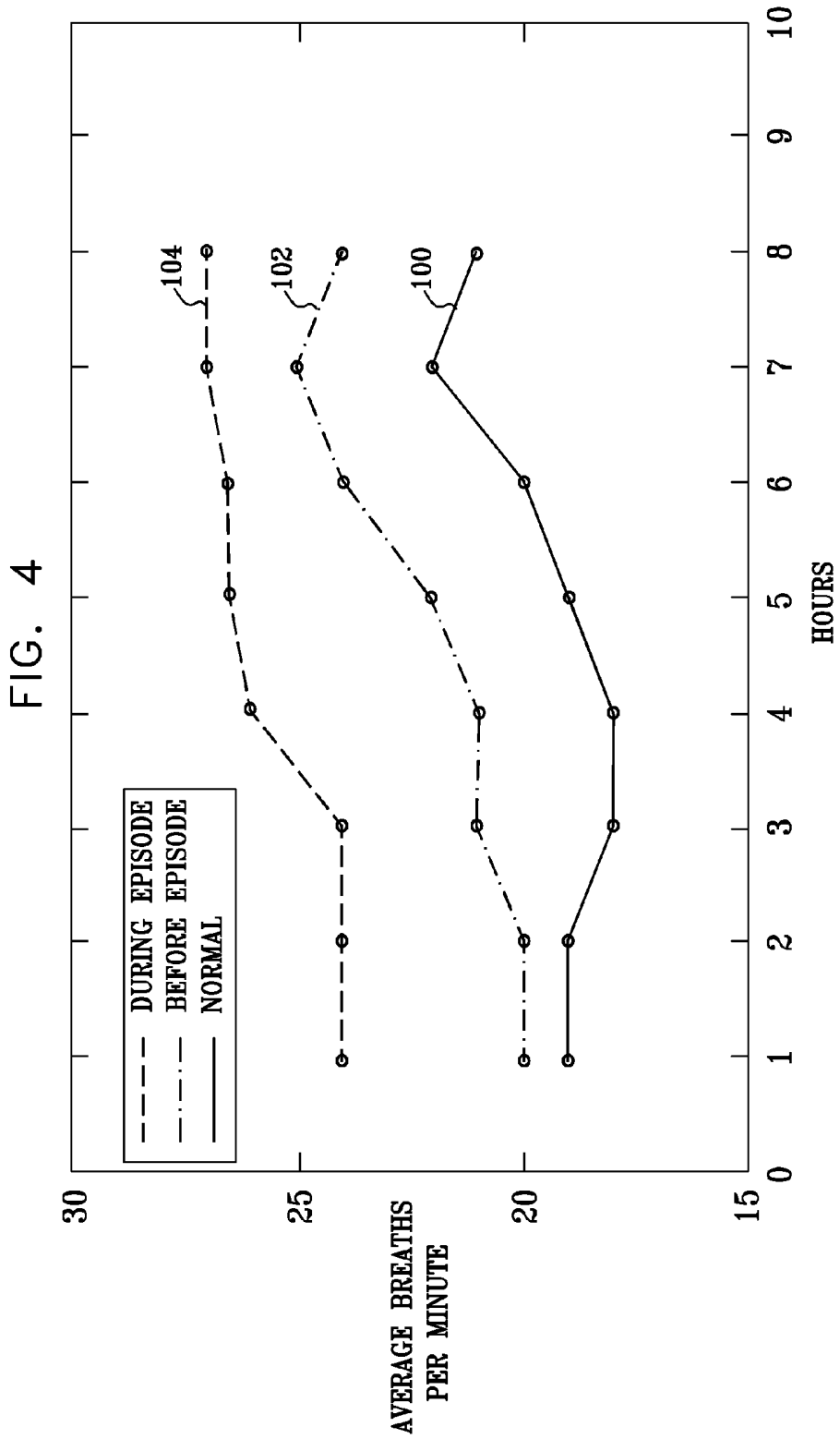

FIG. 5

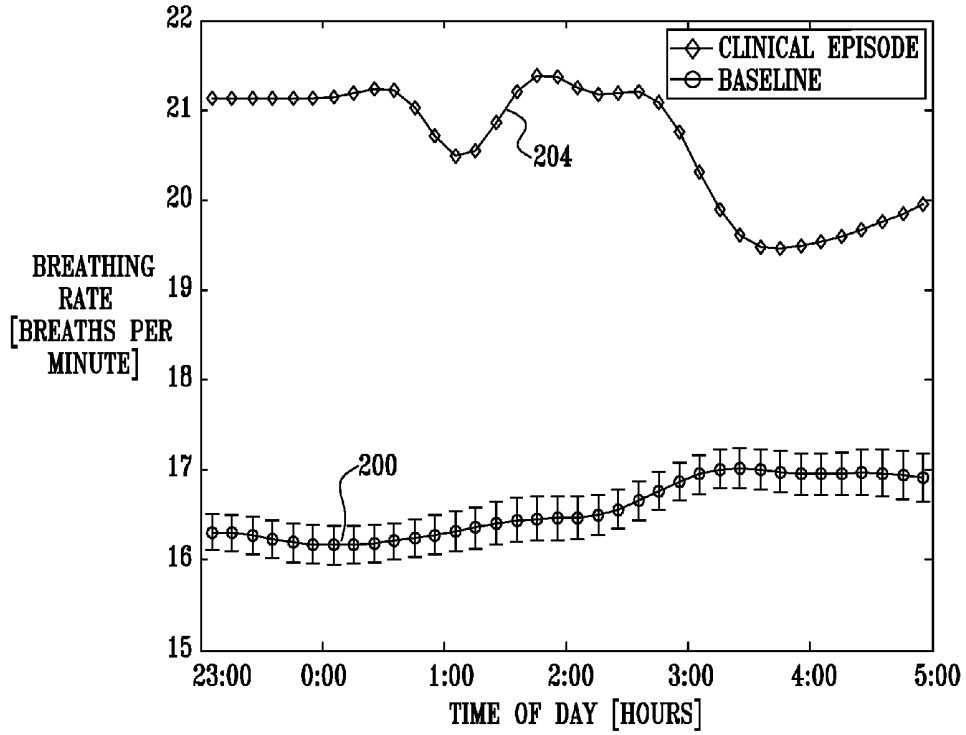

FIG. 6

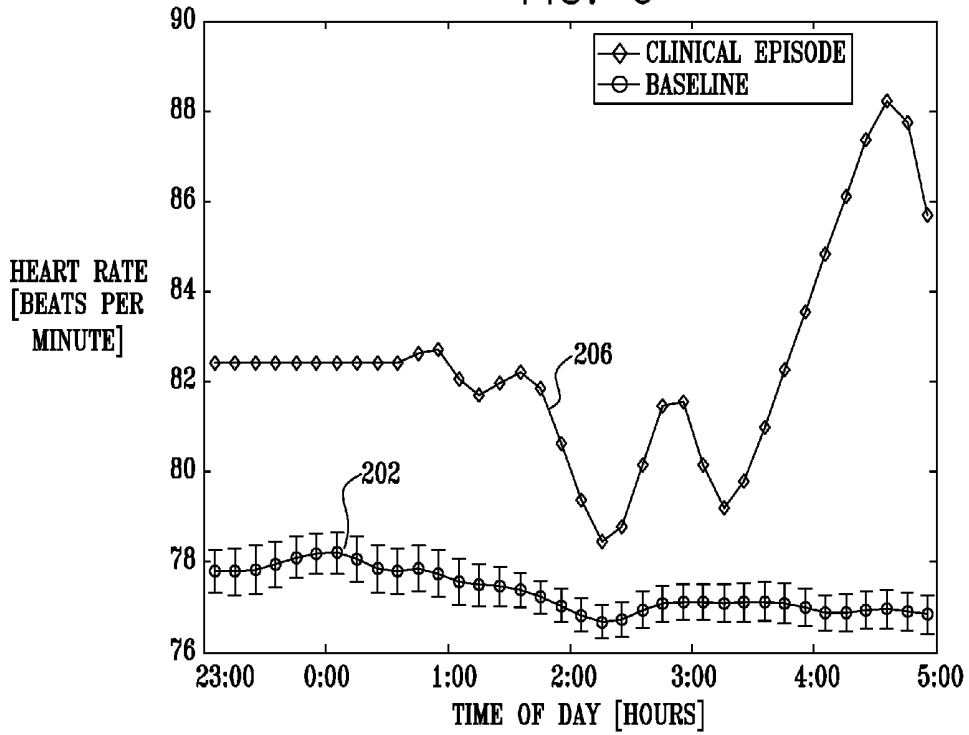
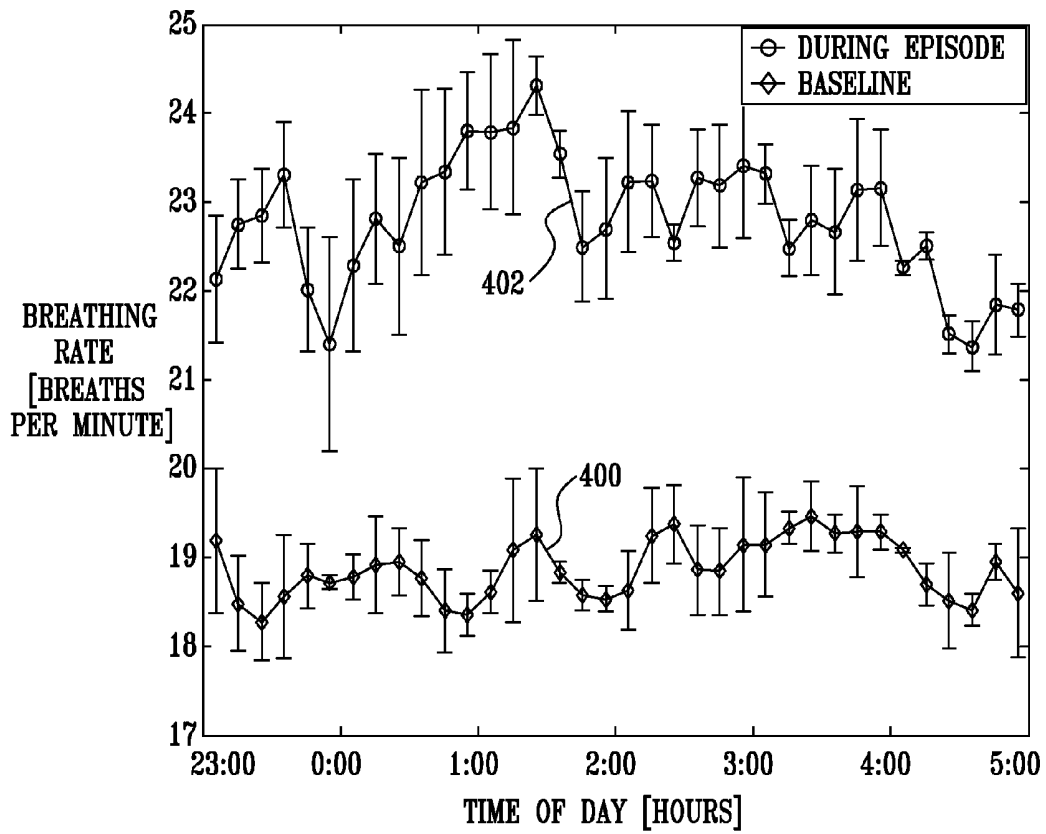

FIG. 7



MONITORING A CONDITION OF A SUBJECT**CROSS-REFERENCES TO RELATED APPLICATIONS**

The present application is:

(i) a continuation of U.S. patent application Ser. No. 13/921,915 to Shinar (published as US 2013/0281866), filed Jun. 19, 2013, which is a continuation of U.S. patent application Ser. No. 13/107,772 to Shinar (now U.S. Pat. No. 8,491,492), filed May 13, 2011, which:

is a continuation-in-part of U.S. patent application Ser. No. 11/782,750 to Halperin (now U.S. Pat. No. 8,403,865), filed Jul. 25, 2007; and

is a continuation-in-part of U.S. patent application Ser. No. 11/552,872 to Pinhas (published as US 2007/0118054), filed Oct. 25, 2006, now abandoned, which claims the benefit of (a) U.S. Provisional Patent Application 60/731,934 to Halperin, filed Nov. 1, 2005, (b) U.S. Provisional Patent Application 60/784,799 to Halperin filed Mar. 23, 2006, and (c) U.S. Provisional Patent Application 60/843,672 to Halperin, filed Sep. 12, 2006; and

(ii) a continuation-in-part of U.S. patent application Ser. No. 13/863,293 to Lange, published as US 2013/0245502, which is a continuation of U.S. patent application Ser. No. 11/552,872 to Pinhas (published as US 2007/0118054), filed Oct. 25, 2006, now abandoned, which claims the benefit of (a) U.S. Provisional Patent Application 60/731,934 to Halperin, filed Nov. 1, 2005, (b) U.S. Provisional Patent Application 60/784,799 to Halperin filed Mar. 23, 2006, and (c) U.S. Provisional Patent Application 60/843,672 to Halperin, filed Sep. 12, 2006.

All of the above-mentioned applications are incorporated herein by reference.

FIELD OF EMBODIMENTS OF THE INVENTION

Some applications of the present invention relate generally to predicting and monitoring physiological conditions. Specifically, some applications relate to methods and apparatus for monitoring a subject by monitoring the subject's respiration rate and/or the subject's heart rate.

BACKGROUND

Chronic diseases are often expressed by episodic worsening of clinical symptoms. Preventive treatment of chronic diseases reduces the overall dosage of required medication and associated side effects, and lowers mortality and morbidity. Generally, preventive treatment should be initiated or intensified as soon as the earliest clinical symptoms are detected, in order to prevent progression and worsening of the clinical episode and to stop and reverse the pathophysiological process. Therefore, the ability to accurately monitor pre-episodic indicators increases the effectiveness of preventive treatment of chronic diseases.

Many chronic diseases cause systemic changes in vital signs, such as breathing and heartbeat patterns, through a variety of physiological mechanisms. For example, common respiratory disorders, such as asthma, chronic obstructive pulmonary disease (COPD), and cystic fibrosis (CF), are direct modifiers of breathing and/or heartbeat patterns. Other chronic diseases, such as diabetes, epilepsy, and certain heart conditions (e.g., congestive heart failure (CHF)), are also known to modify cardiac and breathing activity. In the case of certain heart conditions, such modifications typically occur

because of pathophysiologies related to fluid retention and general cardiovascular insufficiency. Other signs such as coughing and sleep restlessness are also known to be of importance in some clinical situations.

Many chronic diseases induce systemic effects on vital signs. For example, some chronic diseases interfere with normal breathing and cardiac processes during wakefulness and sleep, causing abnormal breathing and heartbeat patterns.

Breathing and heartbeat patterns may be modified via various direct and indirect physiological mechanisms, resulting in abnormal patterns related to the cause of modification. Some respiratory diseases, such as asthma, and some heart conditions, such as CHF, are direct breathing modifiers. Other metabolic abnormalities, such as hypoglycemia and other neurological pathologies affecting autonomic nervous system activity, are indirect breathing modifiers.

Asthma is a chronic disease with no known cure. Substantial alleviation of asthma symptoms is possible via preventive therapy, such as the use of bronchodilators and anti-inflammatory agents. Asthma management is aimed at improving the quality of life of asthma patients.

Monitoring of lung function is viewed as a major factor in determining an appropriate treatment, as well as in patient follow-up. Preferred therapies are often based on aerosol-type medications to minimize systemic side-effects. The efficacy of aerosol type therapy is highly dependent on patient compliance, which is difficult to assess and maintain, further contributing to the importance of lung-function monitoring.

Asthma episodes usually develop over a period of several days, although they may sometimes seem to appear unexpectedly. The gradual onset of the asthmatic episode provides an opportunity to start countermeasures to stop and reverse the inflammatory process. Early treatment at the pre-episode stage may reduce the clinical episode manifestation considerably, and may even prevent the transition from the pre-clinical stage to a clinical episode altogether.

Two techniques are generally used for asthma monitoring. The first technique, spirometry, evaluates lung function using a spirometer, an instrument that measures the volume of air inhaled and exhaled by the lungs. Airflow dynamics are measured during a forceful, coordinated inhalation and exhalation effort by the patient into a mouthpiece connected via a tube to the spirometer. A peak-flow meter is a simpler device that is similar to the spirometer, and is used in a similar manner. The second technique evaluates lung function by measuring nitric-oxide concentration using a dedicated nitric-oxide monitor. The patient breathes into a mouthpiece connected via a tube to the monitor.

Efficient asthma management requires daily monitoring of respiratory function, which is generally impractical, particularly in non-clinical or home environments. Peak-flow meters and nitric-oxide monitors provide a general indication of the status of lung function. However, these monitoring devices do not possess predictive value, and are used as during-episode markers. In addition, peak-flow meters and nitric-oxide monitors require active participation of the patient, which is difficult to obtain from many children and substantially impossible to obtain from infants.

CHF is a condition in which the heart is weakened and unable to circulate blood to meet the body's needs. The subsequent buildup of fluids in the legs, kidneys, and lungs characterizes the condition as congestive. The weakening may be associated with either the left, right, or both sides of the heart, with different etiologies and treatments associated with each type. In most cases, it is the left side of the heart which fails, so that it is unable to efficiently pump blood to the systemic circulation. The ensuing fluid congestion of the lungs results

in changes in respiration, including alterations in rate and/or pattern, accompanied by increased difficulty in breathing and tachypnea.

Quantification of such abnormal breathing provides a basis for assessing CHF progression. For example, Cheyne-Stokes Respiration (CSR) is a breathing pattern characterized by rhythmic oscillation of tidal volume with regularly recurring periods of alternating apnea and hyperpnea. While CSR may be observed in a number of different pathologies (e.g., encephalitis, cerebral circulatory disturbances, and lesions of the bulbar center of respiration), it has also been recognized as an independent risk factor for worsening heart failure and reduced survival in patients with CHF. In CHF, CSR is associated with frequent awakening that fragments sleep, and with concomitant sympathetic activation, both of which may worsen CHF. Other abnormal breathing patterns may involve periodic breathing, prolonged expiration or inspiration, or gradual changes in respiration rate usually leading to tachypnea.

SUMMARY OF EMBODIMENTS

For some applications of the present invention, a subject's respiration rate is monitored for a duration of time of greater than two hours. A parameter of the subject's respiration rate over the time duration, such as the median respiration rate, the mean respiration rate, the maximum respiration rate, and/or a pattern of the respiration rate is determined. The parameter is compared to the same parameter as determined on a previous day during a time period that overlaps with (e.g., is substantially the same as, or partially overlaps with) the time period based upon which the parameter of respiration was determined on the present day. For example, the parameter is compared to the same parameter as determined on a previous day for the same time duration and at the same period (e.g., the same time) of the day. For example, the mean respiration rate over a time duration of three hours, between the times of 8 pm and 11 pm on the present day, may be compared with the mean respiration rate over a time duration of three hours between the times of 8 pm and 11 pm on the previous day. In response thereto, the likelihood of the subject subsequently undergoing an adverse clinical event is determined. Typically, it is determined that the subject is likely to undergo an adverse clinical event by determining that the difference between the parameter of respiration (e.g., the mean respiration rate) of the present day and of the previous day is greater than a threshold amount, e.g., by determining that the parameter of respiration of the present day and that of the previous day are substantially different. Typically, in response to determining that the subject is likely to undergo an adverse clinical event, an alert is generated.

For some applications, the techniques described in the above paragraph with respect to the subject's respiration rate are applied with respect to the subject's heart rate and/or with respect to the subject's respiration rate and the subject's heart rate. For example, it may be determined that the subject is likely to undergo an adverse clinical event by determining that the difference between a parameter of the subject's cardiac cycle (e.g., the mean heart rate over a time duration of greater than two hours at a given period of the day) of the present day and of a previous day is greater than a threshold amount, e.g., by determining that the parameter of the cardiac cycle of the present day and that of the previous day are substantially different. Or, it may be determined that the subject is likely to undergo an adverse clinical event by determining that the difference between a parameter of the subject's cardiac cycle of the present day and of a previous day is

greater than a threshold amount, and the difference between a parameter of the subject's respiration of the present day and of a previous day is greater than a threshold amount.

For some applications of the present invention, a subject's motion is monitored for a duration of time of greater than two hours. A parameter of the subject's motion, such as total duration that the subject is in motion, or percentage of time that the subject is in motion, over the time duration is determined. The parameter is compared to the same parameter as determined on a previous day during a time period that overlaps with (e.g., is substantially the same as, or partially overlaps with) the time period based upon which the parameter of respiration was determined on the present day. For example, the parameter is compared to the same parameter as determined on a previous day for the same time duration and at the same period (e.g., the same time) of the day. For example, the total time that the subject is in motion, or percentage of time that the subject is in motion over a time duration of three hours, between the times of 8 pm and 11 pm on the present day, may be compared with the total time that the subject is in motion, or percentage of time that the subject is in motion over a time duration of three hours between the times of 8 pm and 11 pm on the previous day. In response thereto, the likelihood of the subject subsequently undergoing an adverse clinical event is determined. Typically, it is determined that the subject is likely to undergo an adverse clinical event by determining that the difference between the parameter of motion of the present day and of the previous day is greater than a threshold amount, e.g., by determining that the parameter of motion of the present day and that of the previous day are substantially different. Typically, in response to determining that the subject is likely to undergo an adverse clinical event, an alert is generated.

For some applications, the threshold of the cardiac cycle (described hereinabove) is set responsively to a detected respiration rate, and/or responsively to a detected parameter of the subject's motion. Alternatively or additionally, the threshold of the parameter of the subject's respiration (described hereinabove) is set responsively to the detected heart rate, and/or responsively to a detected parameter of the subject's motion. Further alternatively or additionally, the threshold of the parameter of the subject's motion (described hereinabove) is set responsively to the detected heart rate, and/or responsively to the detected respiration rate.

There is therefore provided, in accordance with some applications of the present invention, apparatus, including:

- a mechanical sensor configured to detect a physiological signal of a subject without contacting or viewing the subject or clothes that the subject is wearing;

- a control unit configured to:

- receive the physiological signal from the sensor over a time duration of at least two hours at a given period of at least one first baseline day,

- determine a physiological parameter of the subject based upon the received physiological signal of the first baseline day;

- receive the physiological signal from the sensor over a time duration of at least two hours at a given period of a second day, the period over which the subject's physiological signal is detected on the second day overlapping with the period over which the subject's physiological signal is detected on the first baseline day;

- determine a physiological parameter of the subject based upon the received physiological signal of the second day;

compare the physiological parameter based upon the received physiological signal of the second day to the baseline physiological parameter of the subject; and generate an alert in response to the comparison; and an output unit configured to output the alert.

For some applications, the physiological sensor is configured to detect the physiological signal of the subject by detecting a respiration rate of the subject.

For some applications, the physiological sensor is configured to detect the physiological signal of the subject by detecting a heart rate of the subject.

For some applications, the physiological sensor is configured to detect the physiological signal of the subject by detecting a parameter of motion of the subject.

There is further provided, in accordance with some applications of the present invention, apparatus, including:

a sensor configured to detect a respiration signal indicative of a respiration rate of a subject; and
a control unit configured to:

receive the detected respiration signal from the sensor over a time duration of at least two hours at a given period of at least one first respiration-rate baseline day;

determine a baseline parameter of the subject's respiration based upon the received respiration signal of the first respiration-rate baseline day;

receive the detected respiration signal from the sensor over a time duration of at least two hours at a given period of a second day, the period over which the subject's respiration is detected on the second day overlapping with the period over which the subject's respiration is detected on the first respiration-rate baseline day;

determine a parameter of the subject's respiration based upon the received respiration signal of the second day; compare the parameter of the subject's respiration based upon the received respiration signal of the second day to the baseline parameter of the subject's respiration; and generate an alert in response to the comparison; and an output unit configured to output the alert.

For some applications, the control unit is configured to determine the baseline parameter of respiration by determining a baseline respiration pattern based upon the received respiration signal of the first respiration-rate baseline day, and the control unit is configured to determine the parameter of the subject's respiration based upon the received respiration signal of the second day by determining a respiration pattern based upon the received respiration signal of the second day.

For some applications:

the control unit is configured to determine the baseline parameter of respiration by determining a parameter selected from the group consisting of: a mean respiration rate, a maximum respiration rate, and a median respiration rate, based upon the received respiration signal of the first respiration-rate baseline day, and

the control unit is configured to determine the parameter of the subject's respiration based upon the received respiration signal of the second day by determining a parameter selected from the group consisting of: a mean respiration rate, a maximum respiration rate, and a median respiration rate, based upon the received respiration signal of the second day.

For some applications, the control unit is configured to:

receive a heart-rate signal from the sensor indicative of a heart rate of the subject over a time duration of at least two hours at a given period of at least one first heart-rate baseline day;

determine a baseline parameter of the subject's cardiac cycle based upon the received heart-rate signal of the first heart-rate baseline day;

receive a heart-rate signal from the sensor indicative of a heart rate of the subject over a time duration of at least two hours at the given period of the second day, the period over which the subject's heart rate is detected on the second day overlapping with the period over which the subject's heart rate is detected on the first heart-rate baseline day;

determine a parameter of the subject's cardiac cycle based upon the received heart-rate signal of the second day; and

compare the parameter of the subject's cardiac cycle based upon the received heart-rate signal of the second day to the baseline parameter of the cardiac cycle, and

generate the alert by generating the alert in response to (a) the comparison of the parameter of the subject's respiration based upon the received respiration signal of the second day to the baseline parameter of the subject's respiration, and (b) the comparison of the parameter of the subject's cardiac cycle based upon the received heart-rate signal of the second day to the baseline parameter of the subject's cardiac cycle.

For some applications, the control unit is configured to:

receive a motion signal from the sensor indicative of motion of the subject over a time duration of at least two hours at a given period of at least one first motion-parameter baseline day;

determine a baseline parameter of the subject's motion based upon the received motion signal of the first motion-parameter baseline day;

receive a motion signal from the sensor indicative of motion of the subject over a time duration of at least two hours at the given period of the second day, the period over which the subject's motion is detected on the second day overlapping with the period over which the subject's motion is detected on the first motion-parameter baseline day;

determine a parameter of the subject's motion based upon the received motion signal of the second day; and compare the parameter of the subject's motion based upon the received motion signal of the second day to the baseline parameter of motion, and

generate the alert by generating the alert in response to (a) the comparison of the parameter of the subject's respiration based upon the received respiration signal of the second day to the baseline parameter of the subject's respiration, and (b) the comparison of the parameter of the subject's motion based upon the received motion signal of the second day to the baseline parameter of the subject's motion.

For some applications, the control unit is configured to compare the parameter of the subject's respiration based upon the received respiration signal of the second day to the baseline parameter of the subject's respiration by determining whether the parameter of the subject's respiration based upon the received respiration signal of the second day differs from the baseline parameter of the subject's respiration by more than a threshold amount.

For some applications, the control unit is configured to:

receive a heart-rate signal from the sensor indicative of a heart rate of the subject; and set the threshold in response to the detected heart-rate signal.

For some applications, the control unit is configured to:

receive a motion signal from the sensor indicative of a motion of the subject; and

set the threshold in response to the detected motion signal.

There is additionally provided, in accordance with some applications of the present invention, apparatus, including:

a sensor configured to detect a heart-rate signal indicative of a heart rate of a subject; and

a control unit configured to:

receive the detected heart-rate signal from the sensor over a time duration of at least two hours at a given period of at least one first heart-rate baseline day;
 determine a baseline parameter of the subject's cardiac cycle based upon the received heart-rate signal of the first heart-rate baseline day;
 receive the detected heart-rate signal from the sensor over a time duration of at least two hours at a given period of a second day, the period over which the subject's heart rate is detected on the second day overlapping with the period over which the subject's heart rate is detected on the first heart-rate baseline day;
 determine a parameter of the subject's cardiac cycle based upon the received heart-rate signal of the second day;
 compare the parameter of the subject's cardiac cycle based upon the received heart-rate signal of the second day to the baseline parameter of the subject's cardiac cycle;
 and
 generate an alert in response to the comparison; and
 an output unit configured to output the alert.

For some applications, the control unit is configured to:
 receive a motion signal from the sensor indicative of motion of the subject over a time duration of at least two hours at a given period of at least one first motion-parameter baseline day;

determine a baseline parameter of the subject's motion based upon the received motion signal of the first motion-parameter baseline day;

receive a motion signal from the sensor indicative of motion of the subject over a time duration of at least two hours at the given period of the second day, the period over which the subject's motion is detected on the second day overlapping with the period over which the subject's motion is detected on the first motion-parameter baseline day;

determine a parameter of the subject's motion based upon the received motion signal of the second day; and

compare the parameter of the subject's motion based upon the received motion signal of the second day to the baseline parameter of motion, and

generate the alert by generating the alert in response to (a) the comparison of the parameter of the subject's cardiac cycle based upon the received heart-rate signal of the second day to the baseline parameter of the subject's cardiac cycle, and (b) the comparison of the parameter of the subject's motion based upon the received motion signal of the second day to the baseline parameter of the subject's motion.

For some applications, the control unit is configured to compare the parameter of the subject's cardiac cycle based upon the received heart-rate signal of the second day to the baseline parameter of the subject's cardiac cycle by determining whether the parameter of the subject's cardiac cycle based upon the received heart-rate signal of the second day differs from the baseline parameter of the subject's cardiac cycle by more than a threshold amount.

For some applications, the control unit is configured to:
 receive a respiration signal from the sensor indicative of a respiration rate of the subject; and
 set the threshold in response to the detected respiration signal.

For some applications, the control unit is configured to:
 receive a motion signal from the sensor indicative of a motion of the subject; and

set the threshold in response to the detected motion signal.
 There is further provided, in accordance with some applications of the present invention, apparatus, including:

a sensor configured to detect a motion signal indicative of motion of a subject; and

a control unit configured to:

receive the detected motion signal from the sensor over a time duration of at least two hours at a given period of at least one first motion-parameter baseline day;

determine a baseline parameter of the subject's motion based upon the received motion signal of the first motion-parameter baseline day;

receive the detected motion signal from the sensor over a time duration of at least two hours at a given period of a second day, the period over which the subject's motion is detected on the second day overlapping with the period over which the subject's motion is detected on the first motion-parameter baseline day;

determine a parameter of the subject's motion based upon the received motion signal of the second day;

compare the parameter of the subject's motion based upon the received motion signal of the second day to the baseline parameter of the subject's motion; and

generate an alert in response to the comparison; and
 an output unit configured to output the alert.

For some applications, the control unit is configured to compare the parameter of the subject's motion based upon the received motion signal of the second day to the baseline parameter of the subject's motion by determining whether the parameter of the subject's motion based upon the received motion signal of the second day differs from the baseline parameter of the subject's motion by more than a threshold amount.

For some applications, the control unit is configured to:

receive a respiration signal from the sensor indicative of a respiration rate of the subject; and set the threshold in response to the detected respiration signal.

For some applications, the control unit is configured to:

receive a heart-rate signal from the sensor indicative of a heart rate of the subject; and

set the threshold in response to the detected heart-rate signal.

There is additionally provided, in accordance with some applications of the present invention, a method including:

detecting a respiration rate of a subject over a time duration of at least two hours at a given period of at least one first respiration-rate baseline day;

determining a baseline parameter of the subject's respiration based upon the detected respiration rate for the first respiration-rate baseline day;

detecting a respiration rate of the subject over a time duration of at least two hours at a given period of a second day, the period over which the subject's respiration is detected on the second day overlapping with the period over which the subject's respiration is detected on the first respiration-rate baseline day;

determining a parameter of the subject's respiration based upon the detected respiration rate on the second day;

comparing the parameter of the subject's respiration based upon the detected respiration rate on the second day to the baseline parameter of the subject's respiration; and
 generating an alert in response to the comparison.

There is further provided, in accordance with some applications of the present invention, a method including:

detecting a heart rate of a subject over a time duration of at least two hours at a given period of at least one first heart-rate baseline day;

determining a baseline parameter of the subject's cardiac cycle based upon the detected heart rate for the first heart-rate baseline day;

detecting a heart rate of the subject over a time duration of at least two hours at a given period of a second day, the period

over which the subject's heart rate is detected on the second day overlapping with the period over which the subject's heart rate is detected on the first heart-rate baseline day;

determining a parameter of the subject's cardiac cycle based upon the detected heart rate on the second day;

comparing the parameter of the subject's cardiac cycle based upon the detected heart rate on the second day to the baseline parameter of the subject's cardiac cycle; and

generating an alert in response to the comparison.

There is additionally provided, in accordance with some applications of the present invention, a method including:

detecting motion of a subject over a time duration of at least two hours at a given period of at least one first motion-parameter baseline day;

determining a motion parameter of the subject's respiration based upon the detected motion for the first motion-parameter baseline day;

detecting motion of the subject over a time duration of at least two hours at a given period of a second day, the period over which the subject's motion is detected on the second day overlapping with the period over which the subject's motion is detected on the first motion-parameter baseline day;

determining a parameter of the subject's motion based upon the motion detected on the second day;

comparing the parameter of the subject's motion based upon the motion detected on the second day to the baseline parameter of the subject's motion; and

generating an alert in response to the comparison.

There is further provided, in accordance with some applications of the present invention, a method including:

detecting a physiological signal of a subject over a time duration of at least two hours at a given period of at least one first baseline day, without contacting or viewing the subject or clothes that the subject is wearing;

determining a physiological parameter of the subject based upon the detected physiological signal for the first baseline day;

detecting the physiological signal of the subject over a time duration of at least two hours at a given period of a second day, the period over which the subject's physiological signal is detected on the second day overlapping with the period over which the physiological signal is detected on the first baseline day;

determining a physiological parameter of the subject based upon the detected physiological signal on the second day;

comparing the physiological parameter based upon the detected physiological signal on the second day to the baseline physiological parameter of the subject; and

generating an alert in response to the comparison.

The present invention will be more fully understood from the following detailed description of embodiments thereof, taken together with the drawings, in which:

BRIEF DESCRIPTION OF THE DRAWINGS

FIG. 1 is a schematic illustration of a system for monitoring a chronic medical condition of a subject, in accordance with some applications of the present invention;

FIG. 2 is a schematic block diagram illustrating components of a control unit of the system of FIG. 1, in accordance with some applications of the present invention;

FIGS. 3A-D are graphs showing the results of experiments conducted, in accordance with some applications of the present invention;

FIG. 4 is a graph illustrating breathing rate patterns of a chronic asthma patient, which is the same as FIG. 4 of U.S. Pat. No. 7,077,810 to Lange, which is incorporated herein by reference;

FIGS. 5 and 6 are graphs of exemplary baseline and measured breathing rate and heart rate nighttime patterns, respectively, which are generally similar to FIGS. 6 and 7 of U.S. Pat. No. 7,314,451 to Halperin, which is incorporated herein by reference; and

FIG. 7 is a graph of baseline and breathing rate nighttime patterns, respectively, which is the same as FIG. 23 of U.S. Pat. No. 7,314,451 to Halperin.

DETAILED DESCRIPTION OF EMBODIMENTS

Reference is made to FIG. 1, which is a schematic illustration of a system 10 for monitoring a chronic medical condition of a subject 12, in accordance with some applications of the present invention. System 10 typically comprises a mechanical sensor 30 (e.g., a motion sensor), a control unit 14, and a user interface 24. For some applications, user interface 24 is integrated into control unit 14, as shown in the figure, while for other applications, the user interface and control unit are separate units. For some applications, motion sensor 30 is integrated into control unit 14, in which case user interface 24 is either also integrated into control unit 14 or remote from control unit 14.

FIG. 2 is a schematic block diagram illustrating components of control unit 14, in accordance with some applications of the present invention. Control unit 14 typically comprises a motion data acquisition module 20 and a pattern analysis module 16. Pattern analysis module 16 typically comprises one or more of the following modules: a breathing pattern analysis module 22, a heartbeat pattern analysis module 23, a cough analysis module 26, a restlessness analysis module 28, a blood pressure analysis module 29, and an arousal analysis module 31. For some applications, two or more of analysis modules 20, 22, 23, 26, 28, 29, and 31 are packaged in a single housing. For other applications, the modules are packaged separately (for example, so as to enable remote analysis by one or more of the pattern analysis modules of breathing signals acquired locally by data acquisition module 20). For some applications, user interface 24 comprises a dedicated display unit such as an LCD or CRT monitor. Alternatively or additionally, user interface 24 includes a communication line for relaying the raw and/or processed data to a remote site for further analysis and/or interpretation.

For some applications of the present invention, data acquisition module 20 is adapted to non-invasively monitor breathing and heartbeat patterns of subject 12. Breathing pattern analysis module 22 and heartbeat pattern analysis module 23 are adapted to analyze the respective patterns in order to (a) predict an approaching clinical event, such as an asthma attack or heart condition-related lung fluid buildup, and/or (b) monitor the severity and progression of a clinical event as it occurs. For some applications, breathing pattern analysis module 22 and heartbeat pattern analysis module 23 are adapted to analyze the respective patterns in order to determine a likelihood of an approaching adverse clinical event without necessarily identifying the nature of the event. User interface 24 is adapted to notify subject 12 and/or a healthcare worker of the predicted or occurring event. Prediction of an approaching clinical event facilitates early preventive treatment, which generally reduces the required dosage of medication, and/or lowers mortality and morbidity. When treating asthma, such a reduced dosage generally minimizes the side-

effects associated with high dosages typically required to reverse the inflammatory condition once the event has begun.

For some applications of the present invention, pattern analysis module 16 combines parameter data generated from two or more of analysis modules 20, 22, 23, 26, 28, 29, and analyzes the combined data in order to predict and/or monitor a clinical event. For some applications, pattern analysis module 16 derives a score for each parameter based on the parameter's deviation from baseline values (either for the specific patient or based on population averages). Pattern analysis module 16 combines the scores, such as by taking an average, maximum, standard deviation, or other function of the scores. The combined score is compared to one or more threshold values (which may be predetermined) to determine whether an event is predicted, currently occurring, or neither predicted nor occurring, and/or to monitor the severity and progression of an occurring event. For some applications, pattern analysis module 16 learns the criteria and/or functions for combining the individual parameter scores for the specific patient or patient group based on personal history. For example, pattern analysis module 16 may perform such learning by analyzing parameters measured prior to previous clinical events.

Although system 10 may monitor breathing and heartbeat patterns at any time, for some conditions it is generally most effective to monitor such patterns during sleep at night. When the subject is awake, physical and mental activities unrelated to the monitored condition often affect breathing and heartbeat patterns. Such unrelated activities generally have less influence during most night sleep. For some applications, system 10 monitors and records patterns throughout all or a large portion of a night. The resulting data set generally encompasses typical long-term respiratory and heartbeat patterns, and facilitates comprehensive analysis. Additionally, such a large data set enables rejection of segments contaminated with movement or other artifacts, while retaining sufficient data for a statistically significant analysis.

Reference is again made to FIG. 2. Data acquisition module 20 typically comprises circuitry for processing the raw motion signal generated by motion sensor 30, such as at least one pre-amplifier 32, at least one filter 34, and an analog-to-digital (A/D) converter 36. Filter 34 typically comprises a band-pass filter or a low-pass filter, serving as an anti-aliasing filter with a cut-off frequency of less than one half of the sampling rate. The low-passed data is typically digitized at a sampling rate of at least 10 Hz and stored in memory. For example, the anti-aliasing filter cut-off may be set to 5 Hz and the sampling rate set to 40 Hz.

Reference is again made to FIG. 1. Typically, motion sensor 30 detects one or more physiological signal of the subject without contacting or viewing the subject or clothes that the subject is wearing. For some applications of the present invention, motion sensor 30 comprises a pressure gauge (e.g., a piezoelectric sensor) or a strain gauge (e.g., a silicon or other semiconductor strain gauge, or a metallic strain gauge), which is typically adapted to be installed in, on, or under a reclining surface 37 upon which the subject lies, e.g., sleeps, and to sense breathing- and heartbeat-related motion of the subject. "Pressure gauge," as used in the claims, includes, but is not limited to, all of the gauges mentioned in the previous sentence. Typically, reclining surface 37 comprises a mattress, a mattress covering, a sheet, a mattress pad, and/or a mattress cover. For some applications, motion sensor 30 is integrated into reclining surface 37, e.g., into a mattress, and the motion sensor and reclining surface are provided together as an integrated unit. For some applications, motion sensor 30 is adapted to be installed in, on, or under reclining surface 37 in a vicinity of an abdomen 38 or chest 39 of subject 12.

Alternatively or additionally, motion sensor 30 is installed in, on, or under reclining surface 37 in a vicinity of a portion of subject 12 anatomically below a waist of the subject, such as in a vicinity of legs 40 of the subject. For some applications, such positioning provides a clearer pulse signal than positioning the sensor in a vicinity of abdomen 38 or chest 39 of the subject. For some applications, motion sensor 30 comprises a fiber optic sensor, for example, as described by Butter and Hocker in *Applied Optics* 17: 2867-2869 (Sep. 15, 1978).

For some applications, the pressure or strain gauge is encapsulated in a rigid compartment, which typically has a surface area of at least 10 cm², and a thickness of less than 5 mm. The gauge output is channeled to an electronic amplifier, such as a charge amplifier typically used with piezoelectric accelerometers and capacitive transducers to condition the extremely high output impedance of the transducer to a low impedance voltage suitable for transmission over long cables. The strain gauge and electronic amplifier translate the mechanical vibrations into electrical signals. Alternatively, the strain gauge output is amplified using a Wheatstone bridge and an amplifier such as Analog Device Module Numbers 3B16, for a minimal bandwidth, or 3B18, for a wider bandwidth (National Instruments Corporation, Austin, Tex., USA).

For some applications of the present invention, motion sensor 30 comprises a grid of multiple pressure or strain gauge sensors, adapted to be installed in, on, or under reclining surface 37. The use of such a grid, rather than a single gauge, may improve breathing and heartbeat signal reception.

Breathing pattern analysis module 22 is adapted to extract breathing patterns from the motion data, and heartbeat pattern analysis module 23 is adapted to extract heartbeat patterns from the motion data. Alternatively or additionally, system 10 comprises another type of sensor, such as an acoustic or air-flow sensor, attached or directed at the subject's face, neck, chest and/or back.

For some applications of the present invention, the subject's respiration rate is monitored for a duration of time of greater than two hours (e.g., greater than three hours, greater than four hours, greater than five hours, or greater than six hours). Breathing pattern analysis module 22 determines a parameter of the subject's respiration rate over the time duration, such as the median respiration rate, the mean respiration rate, the maximum respiration rate, and/or a respiration rate pattern. Module 22 compares the determined parameter to the same parameter as determined on a previous day during a time period that overlaps with the time period based upon which the parameter of respiration was determined on the present day. For example, the parameter is compared to the same parameter as determined on a previous day for the same time duration and at the same period (e.g., the same time) of the day.

For example, the mean respiration rate over a time duration of three hours, between the times of 8 pm and 11 pm on the present day, may be compared with the mean respiration rate over a time duration of three hours between the times of 8 pm and 11 pm on the previous day. In response thereto, the likelihood of the subject subsequently undergoing an adverse clinical event is determined. Typically, it is determined that the subject is likely to undergo an adverse clinical event by determining that the difference between the parameter of respiration (e.g., the mean respiration rate) of the present day and of the previous day is greater than a threshold amount. Typically, in response to determining that the subject is likely to undergo an adverse clinical event, an alert is generated by user interface 24.

For some applications, the period of to the day which is compared to the same period of the previous day is a time period, e.g., between 8 pm and 11 pm, as described hereinabove. Alternatively, the period may be defined with respect to the subject's circadian clock, e.g., the period may be the first three hours of the subject's sleep, or from the beginning of the second hour of the subject's sleep to the end of the fifth hour of the subject's sleep.

For some applications, heartbeat pattern analysis module 23 applies generally similar analysis to the subject's heart rate to that described hereinabove with respect to the breathing pattern analysis module 22. For example, module 23 may determine that the subject is likely to undergo an adverse clinical event by determining that the difference between a parameter of the subject's cardiac cycle (e.g., the mean heart rate over a time duration of greater than two hours at a given period of the day) on the present day and that of a previous day is greater than a threshold amount. For some applications, control unit 24 determines that the subject is likely to undergo an adverse clinical event by determining that the difference between a parameter of the subject's cardiac cycle on the present day and that of a previous day is greater than a threshold amount, and the difference between a parameter of the subject's respiration on the present day and that of the previous day is greater than a threshold amount.

As described hereinabove, for some applications, breathing pattern analysis module 22 and heartbeat pattern analysis module 23 are adapted to analyze the respective patterns in order to determine a likelihood of an approaching adverse clinical event without necessarily identifying the nature of the event. Thus, for some applications, in response to determining that the subject is likely to undergo an adverse clinical event, the user interface generates a generic alert signal, in order to indicate to a healthcare professional that an adverse clinical event is imminent.

For some applications, system 10 applies generally similar analysis to a different physiological parameter of the subject to that described hereinabove with respect to the breathing pattern analysis module 22. For example, the system may apply the analysis to a parameter of the subject's motion, such as the total time that the subject is in motion, or percentage of time that the subject is in motion over a given time duration.

Reference is now made to FIGS. 3A-D, which are graphs showing the results of experiments conducted, in accordance with some applications of the present invention. EarlySense Ltd. (Israel) manufactures the EverOn™ system, which is a contact-less piezoelectric sensor placed under a subject's mattress that provides continuous measurement of heart rate and respiration rate of the subject, generally in accordance with the techniques described hereinabove.

A non-interventional study was conducted in two internal medicine departments (Sheba Medical Center and Meir Medical Center, both in Israel). Patients who were admitted due to an acute respiratory condition were enrolled on the study. Patients were monitored by the EverOn™ sensor and followed for major clinical episodes. A major clinical event was defined as death, transfer to ICU, or intubation and mechanical ventilation on the floors. Out of 149 patients included in the study, 96 patients had a length of stay that allowed at least one comparable time window. Ten major clinical events were recorded for these patients. Retrospective analysis of continuous respiratory and heart signal recording was performed. The median respiration rate and heart rate over 6-hour time durations (00-06, 06-12, 12-18, and 18-24) were compared to the median respiration rate and heart rate over a corresponding 6-hour time duration on the previous day. Similarly, the maximum respiration rate and heart rate

over 6-hour time durations (00-06, 06-12, 12-18, and 18-24) were compared to the maximum respiration rate and heart rate over a corresponding 6-hour time duration on the previous day. Retrospective receiver operating characteristic (ROC) curve analysis was applied to the results to determine the sensitivity, specificity, positive predictive value, and negative predictive value of using respective thresholds (i.e., thresholds for the difference between median or maximum respiration rate or heart rate and those of the previous day) for determining the likelihood of a subject undergoing (a) any adverse clinical event, i.e., either a major or a moderate clinical event (such as a non-major respiratory event requiring immediate intervention, e.g., bilevel positive airway pressure (BIPAP) or continuous positive airway pressure (CPAP)), or (b) a major clinical event.

Table 1 (shown below) shows the results of the ROC curve analysis of respective combinations of median heart rate and respiration rate thresholds (i.e., thresholds for the difference between median heart rate and respiration rate and those of the previous day) with respect to determining the likelihood of a subject undergoing any adverse clinical event, i.e., either a major or a moderate clinical event.

TABLE 1

Threshold Heart rate (beats per minute) – Respiration rate (breaths per minute))	Sensitivity	Specificity	PPV	NPV
14 – 3	67	82	35	95
14 – 4	67	82	35	95
14 – 5	67	86	40	95
14 – 6	58	89	44	94
16 – 3	67	87	42	95
16 – 4	67	87	42	95
16 – 5	67	89	47	95
16 – 6	58	93	54	94
18 – 3	67	89	47	95
18 – 4	67	89	47	95
18 – 5	67	90	50	95
18 – 6	58	94	58	94
20 – 3	67	94	62	95
20 – 4	67	94	62	95
20 – 5	67	95	67	95
20 – 6	58	98	78	94
22 – 3	67	94	62	95
22 – 4	67	94	62	95
22 – 5	67	95	67	95
22 – 6	58	98	78	94

Table 2 (shown below) shows the results of the ROC curve analysis of respective combinations of median heart rate and respiration rate (i.e., thresholds for the difference between median heart rate and respiration rate and those of the previous day) thresholds with respect to determining the likelihood of a subject undergoing a major clinical event.

Threshold (Heart rate (beats per minute) – Respiration rate (breaths per minute))	Sensitivity	Specificity	PPV	NPV
–3	80	83	35	97
14 – 4	80	83	35	97
14 – 5	80	86	40	97
14 – 6	70	90	44	96
16 – 3	80	87	42	97

-continued

Threshold (Heart rate (beats per minute) – Respiration rate (breaths per minute))	Sensitivity	Specificity	PPV	NPV
16 – 4	80	87	42	97
16 – 5	80	90	47	97
16 – 6	70	93	54	96
18 – 3	80	90	47	97
18 – 4	80	90	47	97
18 – 5	80	91	50	98
18 – 6	70	94	58	96
20 – 3	80	94	62	98
20 – 4	80	94	62	98
20 – 5	80	95	67	98
20 – 6	70	98	78	97
22 – 3	80	94	62	98
22 – 4	80	94	62	98
22 – 5	80	95	67	98
22 – 6	70	98	78	97

It is noted with respect to Tables 1 and 2 that the greatest sum of sensitivity and specificity is for thresholds of 20 or 22 for median heart rate in combination with a threshold of 5 for median respiration rate, both for predicting all adverse clinical events (i.e., major and minor adverse clinical events), and for predicting major clinical events.

Thus, for some applications of the present invention, a subject's heart rate and respiration rate are monitored. The median (or mean, or maximum) heart rate and respiration rate over a time duration of more than two hours and less than eight hours (e.g., greater than three hours, greater than four hours, greater than five hours, or greater than six hours) is determined and is compared to the median (or mean, or maximum) heart rate and respiration rate over a similar time duration at a similar period of the day (e.g., at the same time of day) on at least one previous day (e.g., the previous day). In response to determining (a) that the median (or mean, or maximum) heart rate on the present day differs from that of the previous day by a threshold amount of more than 15 beats per minute, e.g., more than 18 beats per minute, and (b) that the median (or mean, or maximum) respiration rate of the present day differs from that of the previous day by a threshold amount of more than 3 breaths per minute, e.g., more than 4 breaths per minute, then an alert is generated in order to indicate that an adverse clinical event is likely to occur.

Table 3 (shown below) shows the results of the ROC curve analysis of respective maximum heart rate thresholds (i.e., thresholds for the difference between the maximum heart rate and that of the previous day) with respect to determining the likelihood of a subject undergoing a major or a moderate clinical event.

TABLE 3

Heart rate threshold (beats per minute)	Sensitivity	Specificity	Sum of Sensitivity and Specificity
0.00	1.00	0.00	1.00
0.25	1.00	0.01	1.01
1.00	1.00	0.02	1.02
3.00	0.92	0.07	0.99
4.00	0.83	0.11	0.94
4.50	0.83	0.17	1.00
5.00	0.83	0.19	1.02
6.00	0.75	0.25	1.00

TABLE 3-continued

Heart rate threshold (beats per minute)	Sensitivity	Specificity	Sum of Sensitivity and Specificity
7.00	0.75	0.32	1.07
8.00	0.75	0.38	1.13
8.50	0.67	0.46	1.13
9.00	0.67	0.48	1.14
10.00	0.67	0.54	1.20
11.00	0.67	0.62	1.29
11.50	0.67	0.70	1.37
12.00	0.67	0.71	1.38
13.00	0.67	0.75	1.42
13.50	0.67	0.79	1.45
14.00	0.67	0.80	1.46
15.00	0.67	0.82	1.49
16.00	0.67	0.85	1.51
17.00	0.67	0.86	1.52
18.00	0.67	0.87	1.54
19.00	0.67	0.89	1.56
20.00	0.67	0.90	1.57
21.00	0.67	0.92	1.58
22.00	0.67	0.93	1.60
22.75	0.58	0.93	1.51
25.00	0.58	0.94	1.52
27.00	0.50	0.95	1.45
28.00	0.42	0.95	1.37
29.00	0.33	0.95	1.29
30.75	0.17	0.95	1.12
32.00	0.08	0.95	1.04
33.00	0.08	0.96	1.05
34.00	0.08	0.98	1.06
53.00	0.00	0.98	0.98
56.00	0.00	0.99	0.99

It is noted with respect to Table 3 that the greatest sum of sensitivity and specificity is for a heart rate threshold of 22 beats per minute, for predicting major and moderate adverse clinical events. FIG. 3A shows the ROC curve for a heart rate threshold of 22 with respect to predicting a likelihood of either a major or a moderate adverse clinical event. The area under the curve is 0.70 with a standard deviation of 0.11 and a p-value of 0.026.

Table 4 (shown below) shows the results of the ROC curve analysis of respective maximum heart rate thresholds (i.e., thresholds for the difference between the maximum heart rate and that of the previous day) with respect to determining the likelihood of a subject undergoing a major clinical event.

TABLE 4

Heart rate threshold (beats per minute)	Sensitivity	Specificity	Sum of Sensitivity and Specificity
0.00	1.00	0.00	1.00
0.25	1.00	0.01	1.01
1.00	1.00	0.02	1.02
3.00	1.00	0.08	1.08
4.00	0.90	0.12	1.02
4.50	0.90	0.17	1.07
5.00	0.90	0.20	1.10
6.00	0.80	0.26	1.06
7.00	0.80	0.33	1.13
8.00	0.80	0.38	1.18
8.50	0.80	0.48	1.28
9.00	0.80	0.49	1.29
10.00	0.80	0.55	1.35
11.00	0.80	0.63	1.43
11.50	0.80	0.71	1.51
12.00	0.80	0.72	1.52
13.00	0.80	0.76	1.56
13.50	0.80	0.79	1.59

TABLE 4-continued

Heart rate threshold (beats per minute)	Sensitivity	Specificity	Sum of Sensitivity and Specificity
14.00	0.80	0.80	1.60
15.00	0.80	0.83	1.63
16.00	0.80	0.85	1.65
17.00	0.80	0.86	1.66
18.00	0.80	0.87	1.67
19.00	0.80	0.90	1.70
20.00	0.80	0.91	1.71
21.00	0.80	0.92	1.72
22.00	0.80	0.93	1.73
22.75	0.70	0.93	1.63
25.00	0.70	0.94	1.64
27.00	0.60	0.95	1.55
28.00	0.50	0.95	1.45
29.00	0.40	0.95	1.35
30.75	0.20	0.95	1.15
32.00	0.10	0.95	1.05
33.00	0.10	0.97	1.07
34.00	0.10	0.98	1.08
53.00	0.00	0.98	0.98
56.00	0.00	0.99	0.99

It is noted with respect to Table 4 that the greatest sum of sensitivity and specificity is for a heart rate threshold of 22 beats per minute for predicting major adverse clinical events. FIG. 3B shows the ROC curve for a heart rate threshold of 22 with respect to predicting a likelihood of a major adverse clinical event. The area under the curve is 0.79 with a standard deviation of 0.11 and a p-value of 0.0024.

In general, in accordance with the indications provided by the data in Tables 3 and 4 and in FIGS. 3A and 3B, a subject's heart rate is monitored. The median (or mean, or maximum) heart rate over a time duration of more than two hours and less than eight hours (e.g., greater than three hours, greater than four hours, greater than five hours, or greater than six hours) is determined and is compared to the median (or mean, or maximum) heart rate over a similar time duration at a similar period of the day (e.g., at the same time of day) on at least one previous day (e.g., the previous day). In response to determining (a) that the median (or mean, or maximum) heart rate of the present day differs from that of the previous day by a threshold amount of more than 15 beats per minute (e.g., more than 18 beats per minute, e.g., more than 20 beats per minute), and/or less than 30 beats per minute, then an alert is generated in order to indicate that an adverse clinical event is likely to occur.

Table 5 (shown below) shows the results of the ROC curve analysis of respective maximum respiration rate thresholds (i.e., thresholds for the difference between the maximum respiration rate and that of the previous day), with respect to determining the likelihood of a subject undergoing a major or a moderate clinical event.

TABLE 5

Respiration rate threshold (breaths per minute)	Sensitivity	Specificity	Sum of Sensitivity and Specificity
0.00	1.00	0.00	1.00
0.50	1.00	0.05	1.05
1.00	1.00	0.06	1.06
1.50	1.00	0.24	1.24
2.00	1.00	0.26	1.26
3.00	1.00	0.43	1.43

TABLE 5-continued

Respiration rate threshold (breaths per minute)	Sensitivity	Specificity	Sum of Sensitivity and Specificity
3.50	1.00	0.58	1.58
4.00	1.00	0.59	1.59
5.00	1.00	0.70	1.70
6.00	0.69	0.76	1.46
6.50	0.54	0.83	1.37
6.75	0.54	0.85	1.39
7.00	0.46	0.85	1.31
7.50	0.38	0.89	1.28
8.00	0.31	0.89	1.20
9.00	0.23	0.92	1.15
10.00	0.23	0.92	1.16
12.00	0.23	0.93	1.16
16.00	0.23	0.97	1.20
18.00	0.15	0.97	1.13
19.00	0.08	0.98	1.06
24.00	0.00	0.98	0.98
35.00	0.00	0.99	0.99

It is noted with respect to Table 5 that the greatest sum of sensitivity and specificity is for a respiration rate threshold of 5 breaths per minute, for predicting major and moderate adverse clinical events. FIG. 3C shows the ROC curve for a respiration rate threshold of 5 with respect to predicting a likelihood of either a major or a moderate adverse clinical event. The area under the curve is 0.84 with a standard deviation of 0.04, and a p-value of 0.000049.

Table 6 (shown below) shows the results of the ROC curve analysis of respective respiration rate thresholds (i.e., thresholds for the difference between the maximum respiration rate and that of the previous day), with respect to determining the likelihood of a subject undergoing a major clinical event.

TABLE 6

Respiration rate threshold (breaths per minute)	Sensitivity	Specificity	Sum of Sensitivity and Specificity
0.00	1.00	0.00	1.00
0.50	1.00	0.05	1.05
1.00	1.00	0.06	1.06
1.50	1.00	0.23	1.23
2.00	1.00	0.26	1.26
3.00	1.00	0.42	1.42
3.50	1.00	0.57	1.57
4.00	1.00	0.58	1.58
5.00	1.00	0.69	1.69
6.00	0.73	0.76	1.49
6.50	0.55	0.83	1.37
6.75	0.55	0.84	1.39
7.00	0.55	0.85	1.40
7.50	0.45	0.89	1.35
8.00	0.36	0.89	1.26
9.00	0.27	0.92	1.19
10.00	0.27	0.93	1.20
12.00	0.27	0.93	1.21
16.00	0.27	0.97	1.24
18.00	0.18	0.98	1.16
19.00	0.09	0.98	1.07
24.00	0.00	0.98	0.98
35.00	0.00	0.99	0.99

It is noted with respect to Table 6 that the greatest sum of sensitivity and specificity is for a respiration rate threshold of 5 breaths per minute for predicting major adverse clinical events. FIG. 3D shows the ROC curve for a respiration rate threshold of 5 with respect to predicting a likelihood of a

major adverse clinical event. The area under the curve is 0.85 with a standard deviation of 0.04, and a p-value of 0.00012.

In general, in accordance with the indications provided by the data in Tables 5 and 6 and in FIGS. 3C and 3D, a subject's respiration rate is monitored. The median (or mean, or maximum) respiration rate over a time duration of more than two hours and less than eight hours (e.g., greater than three hours, greater than four hours, greater than five hours, or greater than six hours) is determined and is compared to the median (or mean, or maximum) respiration rate over a similar time duration at a similar period of the day (e.g., at the same time of day) on at least one previous day (e.g., the previous day). In response to determining (a) that the median (or mean, or maximum) respiration rate of the present day differs from that of the previous day by a threshold amount of more than 3 breaths per minute (e.g., more than 4 breaths per minute), and/or less than 10 breaths per minute (e.g., less than eight, or less than six breaths per minute), then an alert is generated in order to indicate that an adverse clinical event is likely to occur.

For some applications, the techniques described herein are used in combination with the techniques described in one or more of the following references, both of which are incorporated herein by reference:

U.S. Pat. No. 7,077,810 to Lange; and/or

U.S. Pat. No. 7,314,451 to Halperin.

For example, for some applications, as is generally described in U.S. Pat. No. 7,077,810 to Lange, pattern analysis module 22 is configured to predict the onset of an asthma attack or a different clinical event, and/or monitor its severity and progression. Module 22 typically analyzes changes in breathing rate and in breathing rate variability patterns in combination to predict the onset of an asthma attack. Although breathing rate typically slightly increases prior to the onset of an attack, this increase alone is not always a specific marker of the onset of an attack. Therefore, in order to more accurately predict the onset of an attack, and monitor the severity and progression of an attack, module 22 typically additionally analyzes changes in breathing rate variability patterns. For some applications, module 22 compares one or more of the following patterns to respective baseline patterns, and interprets a deviation from baseline as indicative of (a) the onset of an attack, and/or (b) the severity of an attack in progress:

a slow trend breathing rate pattern. Module 22 interprets as indicative of an approaching or progressing attack an increase vs. baseline, for example, for generally healthy subjects, an attenuation of the typical segmented, monotonic decline of breathing rate typically over at least 1 hour, e.g., over at least 2, 3, or 4 hours, or the transformation of this decline into an increasing breathing rate pattern, depending on the severity of the attack;

a breathing rate variability pattern. Module 22 interprets as indicative of an approaching or progressing attack a decrease in breathing rate variability. Such a decrease generally occurs as the onset of an episode approaches, and intensifies with the progression of shortness of breath during an attack;

a breathing duty-cycle pattern. Module 22 interprets a substantial increase in the breathing duty-cycle as indicative of an approaching or progressing attack. Breathing duty-cycle patterns include, but are not limited to, inspirium time/total breath cycle time, expirium time/total breath cycle time, and (inspirium+expirium time)/total breath cycle time; and

interruptions in breathing pattern such as caused by coughs, sleep disturbances, or waking. Module 22 quan-

tifies these events, and determines their relevance to prediction of potential asthma attacks.

Reference is made to FIG. 4, which is a graph illustrating breathing rate patterns of a chronic asthma patient, and which is the same as FIG. 4 of U.S. Pat. No. 7,077,810 to Lange. Breathing of the asthma patient was monitored during sleep on several nights. The patient's breathing rate was averaged for each hour of sleep (excluding periods of rapid eye movement (REM) sleep). During the first approximately two months that the patient was monitored, the patient did not experience any episodes of asthma. A line 100 is representative of a typical slow trend breathing pattern recorded during this non-episodic period, and thus represents a baseline slow trend breathing rate pattern for this patient. It should be noted that, unlike the monotonic decline in breathing rate typically observed in non-asthmatic patients, the baseline breathing rate pattern of the chronically asthmatic patient of the experiment reflects an initial decline in breathing rate during the first few hours of sleep, followed by a gradual increase in breathing rate throughout most of the rest of the night.

Lines 102 and 104 were recorded on two successive nights at the conclusion of the approximately two-month period, line 102 on the first of these two nights, and line 104 on the second of these two nights. The patient experienced an episode of asthma during the second of these nights. Lines 102 and 104 thus represent a pre-episodic slow trend breathing rate pattern and an episodic slow trend breathing rate pattern, respectively. As can be seen in the graph, the patient's breathing rate was substantially elevated vs. baseline during all hours of the pre-episodic night, and even further elevated vs. baseline during the episodic night.

Using techniques described herein, the pattern of line 102 is compared with the baseline pattern of line 100, in order to predict that the patient may experience an asthmatic episode. The pattern of line 104 is compared with the baseline pattern of line 100 in order to assess a progression of the asthmatic episode.

In accordance with the data shown in FIG. 4, for some applications, a subject's respiration is detected on first and second days over similar time durations and at similar time periods (e.g., during the first two, three four, five, or six hours of the subject's sleep). A parameter of the subject's respiration based upon the detected respiration rate on the second day is compared with that of the first day. An alert is generated in response to the comparison indicating that an adverse clinical event is approaching, e.g., in response to determining that the difference between the median, the mean, and/or the maximum respiration rate on the second day and that of the first day exceeds a threshold.

For some applications, techniques as described in U.S. Pat. No. 7,314,451 to Halperin are used in conjunction with the techniques described herein. For example, for some applications, system 10 monitors and records patterns throughout all or a large portion of a night. The resulting data set generally encompasses typical long-term respiratory and heartbeat patterns, and facilitates comprehensive analysis. Additionally, such a large data set enables rejection of segments contaminated with movement or other artifacts, while retaining sufficient data for a statistically significant analysis.

Although breathing rate typically slightly increases prior to the onset of an asthma attack (or a different adverse clinical event), this increase alone is not always a specific marker of the onset of an attack. Therefore, in order to more accurately predict the onset of an attack, and monitor the severity and progression of an attack, in an embodiment of the present invention, breathing pattern analysis module 22 additionally analyzes changes in breathing rate variability patterns. For

some applications, module 22 compares one or more of the following patterns to respective baseline patterns, and interprets a deviation from baseline as indicative of (a) the onset of an attack, and/or (b) the severity of an attack in progress:

- a slow trend breathing rate pattern. Module 22 interprets as indicative of an approaching or progressing attack an increase vs. baseline, for example, for generally healthy subjects, an attenuation of the typical segmented, monotonic decline of breathing rate typically over at least 1 hour, e.g., over at least 2, 3, or 4 hours, or the transformation of this decline into an increasing breathing rate pattern, depending on the severity of the attack;
- a breathing rate pattern. Module 22 interprets as indicative of an approaching or progressing attack an increase or lack of decrease in breathing rate during the first several hours of sleep, e.g., during the first 2, 3, or 4 hours of sleep.
- a breathing rate variability pattern. Module 22 interprets a decrease in breathing rate variability as indicative of an approaching or progressing attack. Such a decrease generally occurs as the onset of an episode approaches, and intensifies with the progression of shortness of breath during an attack;
- a breathing duty-cycle pattern. Module 22 interprets a substantial increase in the breathing duty-cycle as indicative of an approaching or progressing attack. Breathing duty-cycle patterns include, but are not limited to, inspirium time/total breath cycle time, expirium time/total breath cycle time, and (inspirium+expirium time)/total breath cycle time;
- a change in breathing rate pattern towards the end of night sleep (typically between about 3:00 A.M. and about 6:00 A.M.); and
- interruptions in breathing pattern such as caused by coughs, sleep disturbances, or waking. Module 22 quantifies these events, and determines their relevance to prediction of potential asthma attacks.

Pattern analysis modules 22 and 23 typically determine baseline patterns by analyzing breathing and/or heart rate patterns, respectively, of the subject during non-symptomatic nights. Alternatively or additionally, modules 22 and 23 are programmed with baseline patterns based on population averages. For some applications, such population averages are segmented by characteristic traits such as age, height, weight, and gender.

Reference is again made to FIG. 4, which is a graph illustrating breathing rate patterns of a chronic asthma patient, measured during an experiment conducted in accordance with an embodiment of the present invention. Using techniques described herein, breathing pattern analysis module 22 compares the pattern of line 102 with the baseline pattern of line 100, in order to predict that the patient may experience an asthmatic episode. Module 22 compares the pattern of line 104 with the baseline pattern of line 100 in order to assess a progression of the asthmatic episode.

For some applications of the present invention, the deviation from baseline is defined as the cumulative deviation of the measured pattern from the baseline pattern. A threshold indicative of a clinical condition is set equal to a certain number of standard errors (e.g., one standard error). Alternatively or additionally, other measures of deviation between measured and baseline patterns are used, such as correlation coefficient, mean square error, maximal difference between the patterns, and the area between the patterns. Further alternatively or additionally, pattern analysis module 16 uses a weighted analysis emphasizing specific regions along the patterns, for example, by giving increased weight (e.g.,

double weight) to an initial portion of sleep (e.g., the first two hours of sleep) or to specific hours, for example as morning approaches (e.g., the hours of 3:00-6:00 a.m.).

Reference is now made to FIGS. 5 and 6, which are graphs of exemplary baseline and measured breathing rate and heart rate nighttime patterns, respectively, and which are generally similar to FIGS. 6 and 7 of U.S. Pat. No. 7,314,451 to Halperin, which is incorporated herein by reference. Lines 200 and 202 (FIGS. 5 and 6, respectively) represent normal baseline patterns in the absence of an asthma attack. The bars represent one standard error. Lines 204 and 206 (FIGS. 5 and 6, respectively) represent patterns during nights prior to an onset of an asthma attack. Detection of the change in pattern between lines 200 and 202 and lines 204 and 206, respectively, enables the early prediction of the approaching asthma attack, or other approaching adverse clinical events.

For some applications of the present invention, pattern analysis module 16 is configured to predict the onset of a clinical manifestation of heart failure, and/or monitor its severity and progression. Module 16 typically determines that an episode is imminent when the module detects increased breathing rate accompanied by increased heart rate, and/or when the monitored breathing and/or heartbeat patterns have specific characteristics that relate to heart failure, such as characteristics that are indicative of apnea, Cheyne-Stokes Respiration (CSR), and/or periodic breathing.

In accordance with the data shown in FIG. 5, for some applications, a subject's respiration is detected on first and second days over similar time durations and at similar time periods (e.g., during the first two, three four, five, or six hours of the subject's sleep). A parameter of the subject's respiration based upon the detected respiration rate on the second day is compared with that of the first day. An alert is generated in response to the comparison indicating that an adverse clinical event is approaching, e.g., in response to determining that the difference between the median, the mean, and/or the maximum respiration rate on the second day and that of the first day exceeds a threshold.

In accordance with the data shown in FIG. 6, for some applications, a subject's heart rate is detected on first and second days over similar time durations and at similar time periods (e.g., during the first two, three, four, five, or six hours of the subject's sleep). A parameter of the subject's cardiac cycle based upon the detected heart rate on the second day is compared with that of the first day. An alert is generated in response to the comparison indicating that an adverse clinical event is approaching, e.g., in response to determining that the difference between the median, the mean, and/or the maximum heart rate on the second day and that of the first day exceeds a threshold.

In accordance with the data shown in FIGS. 5 and 6, for some applications, a subject's respiration rate and heart rate are detected on first and second days over similar time durations and at similar time periods (e.g., during the first two, three four, five, or six hours of the subject's sleep). A parameter of the subject's respiration based upon the detected respiration rate on the second day is compared with that of the first day, and a parameter of the subject's cardiac cycle based upon the detected heart rate on the second day is compared with that of the first day. An alert is generated in response to the comparisons indicating that an adverse clinical event is approaching, e.g., in response to determining that (a) the difference between the median, the mean, and/or the maximum respiration rate on the second day and that of the first day exceeds a threshold, and/or (b) the difference between the median, the mean, and/or the maximum heart rate on the second day and that of the first day exceeds a threshold.

Reference is now made to FIG. 7, which is the same as FIG. 23 of U.S. Pat. No. 7,314,451 to Halperin, which is incorporated herein by reference. FIG. 7 is a graph of baseline and breathing rate nighttime patterns, respectively, measured in accordance with some applications of the present invention. A line 400 represents a normal baseline pattern in the absence of Cheyne-Stokes Respiration, and a line 402 represents a pattern during a night during CSR. The bars represent one standard error. In accordance with the data shown in FIG. 7, for some applications, a subject's respiration is detected on first and second days over similar time durations and at similar time periods (e.g., during the first two, three four, five, or six hours of the subject's sleep). A parameter of the subject's respiration based upon the detected respiration rate on the second day is compared with that of the first day. An alert is generated in response to the comparison indicating that an adverse clinical event is approaching, e.g., in response to determining that the difference between the median, the mean, and/or the maximum respiration rate on the second day and that of the first day exceeds a threshold.

For some applications, techniques described herein are used in conjunction with techniques as are generally described in US 2007/0118054 to Pinhas, which is incorporated herein by reference. For example, as is described with reference to FIG. 18 of US 2007/0118054 to Pinhas, for some applications, system 10 is adapted to monitor multiple clinical parameters such as respiration rate, heart rate, cough occurrence, body movement, deep inspirations, expiration/inspiration ratio, of subject 12. Pattern analysis module 16 is adapted to analyze the respective patterns in order to identify a change in the baseline pattern of the clinical parameters. In some cases, this change, a new baseline that is significantly different from the previous baseline indicates, for example, a change in medication and provides the caregiver or healthcare professional with feedback on the efficacy of treatment.

For some applications, system 10 calculates the average respiration rate and heart rate for predefined time segments. Such time segments can be minutes, hours, or days. By analyzing the history of the patient the system can calculate the correlation of respiration rate and heart rate patterns. When an onset of an asthma attack approaches the correlation of heart rate and respiration rate pattern shows a clear change. For each night the respiration rate and heart rate in sleep during the hours of 11:00 pm to 6:00 am (or over a different time period) is averaged. For each date, a respiration vector of length N with the average respiration rate of the last N nights and a heart rate vector of length N with the average heart rate for the last N nights is defined. N is typically between 3 and 30, for example 10. The correlation coefficient of the heart rate vector and the respiration vector is calculated for each date by system 10. A moving window of several days is used to calculate correlation coefficient changes between the respiration and heart rate vectors. A steady correlation coefficient pattern over at least several days is required to identify a significant change of correlation coefficient from one time interval to another. A significant change is defined as a change in the correlation coefficient level of a magnitude larger than the typical correlation coefficient variation in the previous time interval, e.g., a change larger than 3 standard deviations of the correlation coefficient signal in the previous time inter-

val. System 10 identifies such a significant change as an indication of an approaching clinical event.

As described in US 2007/0118054 to Pinhas, for some applications, during sleep, sleep stage is identified using techniques described therein. For each identified sleep stage, the average respiration rate, heart rate and other clinical parameters are calculated. This data is compared to baseline defined for that subject for each identified sleep stage, in order to identify the onset or progress of a clinical episode.

For some applications, for each night, for each hour (or for longer durations of time, such as more than two hours, as described hereinabove) of sleep, counted from the onset of sleep, the average respiration rate, heart rate and other clinical parameters are calculated. This data is compared to baseline in order to identify the onset or progress of a clinical episode.

For some applications, for each night, for each hour (or for longer durations of time, such as more than two hours, as described hereinabove), the average respiration rate, heart rate and other clinical parameters are calculated. This data is compared to baseline in order to identify the onset or progress of a clinical episode. For example, the average respiration rate in sleep during 2:00 AM-3:00 AM is calculated and compared to baseline for that subject in order to identify the onset or progress of a clinical episode.

It will be appreciated by persons skilled in the art that the present invention is not limited to what has been particularly shown and described hereinabove. Rather, the scope of the present invention includes both combinations and subcombinations of the various features described hereinabove, as well as variations and modifications thereof that are not in the prior art, which would occur to persons skilled in the art upon reading the foregoing description.

The invention claimed is:

1. A method for monitoring an onset of a respiratory episode in a subject, the method comprising:
 - sensing a plurality of respirations of the subject without contacting the subject and generating a plurality of respiration signals corresponding to the plurality of respirations;
 - combining the plurality of respiration signals to provide a characteristic respiration parameter of the subject; and predicting the onset of the respiratory episode from the characteristic respiration parameter.
2. The method as recited in claim 1, wherein the combining comprises synchronized averaging.
3. The method as recited in claim 2, wherein the synchronized averaging comprises aligning the plurality of respiration signals.
4. The method as recited in claim 3, wherein the aligning comprises aligning a respiration signal attribute.
5. The method as recited in claim 1, wherein the combining the plurality of respiration signals to provide a characteristic respiration parameter comprises calculating a respiration score from the plurality of respiration signals.
6. The method as recited in claim 1, wherein the method is practiced without contacting or viewing clothes the subject is wearing.
7. The method as recited in claim 1, wherein the method is practiced without requiring compliance of the subject.

* * * *

专利名称(译)	监测受试者的状况		
公开(公告)号	US8840564	公开(公告)日	2014-09-23
申请号	US14/150115	申请日	2014-01-08
[标]申请(专利权)人(译)	EARLYSENSE		
申请(专利权)人(译)	EARLYSENSE LTD.		
当前申请(专利权)人(译)	早期SENSE LTD.		
[标]发明人	PINHAS ITZHAK HALPERIN AVNER LANGE DANIEL H		
发明人	PINHAS, ITZHAK HALPERIN, AVNER LANGE, DANIEL H.		
IPC分类号	A61B5/08 A61B5/00 A61B5/0205 A61B5/113		
CPC分类号	A61B5/0205 A61B5/7282 A61B5/113 A61B5/0816 A61B5/4806 A61B5/02 A61B5/11 A61B5/024 A61B5/4839 A61B5/7275 A61B5/02405 A61B5/08 A61B5/14532 A61B5/746 A61B5/7278 A61B5/0823 A61B5/4818 A61B5/6892 G16H20/40 G16H40/63 G16H50/30		
代理人(译)	麦卡锡KEVIN D.		
优先权	60/784799 2006-03-23 US 60/843672 2006-09-12 US 60/731934 2005-11-01 US		
其他公开文献	US20140171816A1		
外部链接	Espacenet USPTO		

摘要(译)

描述了装置和方法，包括用于监测受试者中呼吸发作的发作的方法。在不接触对象的情况下感测对象的多个呼吸，并且生成与多个呼吸对应的多个呼吸信号。组合多个呼吸信号以提供受试者的特征呼吸参数。从特征呼吸参数预测呼吸事件的发作。还描述了其他应用。

