



US009420956B2

(12) **United States Patent**
Gopalakrishnan et al.

(10) **Patent No.:** **US 9,420,956 B2**
(45) **Date of Patent:** **Aug. 23, 2016**

(54) **METHODS AND SYSTEMS FOR**
ARRHYTHMIA TRACKING AND SCORING

(71) Applicant: **AliveCor, Inc.**, San Francisco, CA (US)
(72) Inventors: **Ravi Gopalakrishnan**, San Francisco, CA (US); **Lev Korzinov**, San Francisco, CA (US); **Fei Wang**, San Francisco, CA (US); **Euan Thomson**, San Francisco, CA (US); **Nupur Srivastava**, San Francisco, CA (US); **Omar Dawood**, San Francisco, CA (US); **Iman Abuzeid**, San Francisco, CA (US); **David E Albert**, San Francisco, CA (US)

(73) Assignee: **ALIVECOR, INC.**, San Francisco, CA (US)

(*) Notice: Subject to any disclaimer, the term of this patent is extended or adjusted under 35 U.S.C. 154(b) by 0 days.

(21) Appl. No.: **14/569,513**

(22) Filed: **Dec. 12, 2014**

(65) **Prior Publication Data**

US 2015/0164349 A1 Jun. 18, 2015

Related U.S. Application Data

(60) Provisional application No. 61/915,113, filed on Dec. 12, 2013, provisional application No. 61/953,616, filed on Mar. 14, 2014, provisional application No. 61/969,019, filed on Mar. 21, 2014, provisional application No. 61/970,551, filed on Mar. 26, 2014, provisional application No. 62/014,516, filed on Jun. 19, 2014.

(51) **Int. Cl.**
A61B 5/02 (2006.01)
A61B 5/04 (2006.01)

(Continued)

(52) **U.S. Cl.**
CPC **A61B 5/02055** (2013.01); **A61B 5/0022** (2013.01); **A61B 5/0245** (2013.01);

(Continued)

(58) **Field of Classification Search**
USPC 600/508-509
See application file for complete search history.

(56) **References Cited**

U.S. PATENT DOCUMENTS

3,717,857 A 2/1973 Evans
3,731,311 A 5/1973 Williams

(Continued)

FOREIGN PATENT DOCUMENTS

CH 675675 A5 10/1990
CN 101828915 A 9/2010

(Continued)

OTHER PUBLICATIONS

Adidas miCoach Pacer Review: Like Nike+, Only Better; printed from website <http://gizmodo.com/5479456/adidas>. printed on Mar. 4, 2010. 5 pages.

(Continued)

Primary Examiner — Nicole F Lavert

(74) *Attorney, Agent, or Firm* — Wilson Sonsini Goodrich & Rosati

(57) **ABSTRACT**

A dashboard centered around arrhythmia or atrial fibrillation tracking is provided. The dashboard includes a heart or cardiac health score that can be calculated in response to data from the user such as their ECG and other personal information and cardiac health influencing factors. The dashboard also provides to the user recommendations or goals, such as daily goals, for the user to meet and thereby improve their heart or cardiac health score. These goals and recommendations may be set by the user or a medical professional and routinely updated as his or her heart or cardiac health score improves or otherwise changes. The dashboard is generally displayed from an application provided on a smartphone or tablet computer of the user.

21 Claims, 16 Drawing Sheets

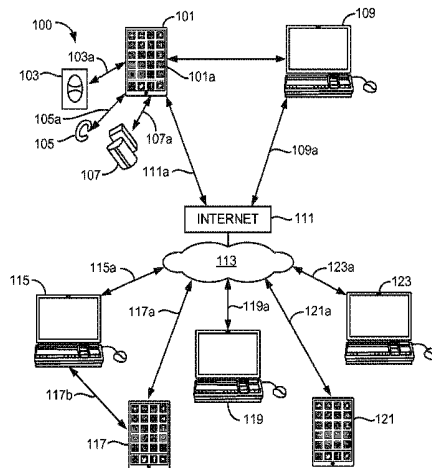

(51)	Int. Cl.								
	<i>A61B 5/0205</i>	(2006.01)		5,191,891 A		3/1993	Righter		
	<i>A61B 5/024</i>	(2006.01)		5,201,321 A		4/1993	Fulton		
	<i>A61B 5/0245</i>	(2006.01)		5,218,969 A		6/1993	Bredesen et al.		
	<i>A61B 5/046</i>	(2006.01)		5,226,424 A		7/1993	Bible		
	<i>A61B 5/00</i>	(2006.01)		5,238,001 A		8/1993	Gallant et al.		
	<i>A61B 5/021</i>	(2006.01)		D341,659 S		11/1993	Homayoun et al.		
	<i>A61B 5/0452</i>	(2006.01)		5,259,387 A		11/1993	DePinto		
	<i>A61B 5/11</i>	(2006.01)		5,301,679 A		4/1994	Taylor		
	<i>G06F 19/00</i>	(2011.01)		5,304,186 A		4/1994	Semler et al.		
(52)	U.S. Cl.			5,313,953 A		5/1994	Yomtov et al.		
	CPC	<i>A61B5/02405</i> (2013.01); <i>A61B 5/02416</i>		5,321,618 A		6/1994	Gessman		
		(2013.01); <i>A61B 5/046</i> (2013.01); <i>A61B</i>		5,333,616 A		8/1994	Mills et al.		
		<i>5/6898</i> (2013.01); <i>A61B 5/7264</i> (2013.01);		5,336,245 A		8/1994	Adams et al.		
		<i>A61B 5/7275</i> (2013.01); <i>G06F 19/3418</i>		5,337,752 A		8/1994	Reeves		
		(2013.01); <i>A61B 5/021</i> (2013.01); <i>A61B</i>		5,339,824 A		8/1994	Engira		
		<i>5/02438</i> (2013.01); <i>A61B 5/0452</i> (2013.01);		5,343,869 A		9/1994	Pross et al.		
		<i>A61B 5/1118</i> (2013.01); <i>A61B 5/681</i> (2013.01);		5,343,870 A		9/1994	Gallant et al.		
		<i>G06F 19/322</i> (2013.01); <i>G06F 19/3487</i>		5,348,008 A		9/1994	Bornn et al.		
		(2013.01)		5,360,005 A		11/1994	Wilk		
(56)	References Cited			5,365,935 A		11/1994	Righter et al.		
	U.S. PATENT DOCUMENTS			5,410,587 A		4/1995	Grunwell		
				5,417,222 A		5/1995	Dempsey et al.		
				5,433,736 A		7/1995	Nilsson		
				5,452,356 A		9/1995	Albert		
				5,466,246 A		11/1995	Silvian		
				5,467,773 A		11/1995	Bergelson et al.		
				5,481,255 A		1/1996	Albert et al.		
				5,503,158 A		4/1996	Coppock et al.		
				5,518,001 A		5/1996	Snell		
				5,522,396 A		6/1996	Langer et al.		
				5,539,705 A		7/1996	Akerman et al.		
				D372,785 S		8/1996	Sabri et al.		
				5,544,661 A		8/1996	Davis et al.		
				5,551,953 A		9/1996	Lattin et al.		
				5,561,712 A		10/1996	Nishihara		
				5,568,448 A		10/1996	Tanigushi et al.		
				5,579,284 A		11/1996	May		
				D377,983 S		2/1997	Sabri et al.		
				5,608,723 A		3/1997	Felsenstein		
				5,634,468 A		6/1997	Platt et al.		
				5,652,570 A		7/1997	Lepkofker		
				5,661,699 A		8/1997	Sutton		
				5,675,325 A		10/1997	Taniguchi et al.		
				5,678,562 A		10/1997	Sellers		
				5,701,894 A		12/1997	Cherry et al.		
				5,704,364 A		1/1998	Saltzstein et al.		
				5,724,025 A		3/1998	Tavori		
				5,730,143 A		3/1998	Schwarzberg		
				5,735,285 A		4/1998	Albert et al.		
				5,742,251 A		4/1998	Gerber		
				5,748,103 A		5/1998	Flach et al.		
				5,764,763 A		6/1998	Jensen et al.		
				5,772,586 A		6/1998	Heinonen et al.		
				5,818,788 A		10/1998	Kimura et al.		
				5,825,718 A		10/1998	Ueki et al.		
				5,827,179 A		10/1998	Lichter et al.		
				5,840,020 A		11/1998	Heinonen et al.		
				5,844,997 A		12/1998	Murphy, Jr.		
				5,861,018 A		1/1999	Feierbach		
				5,873,369 A		2/1999	Laniado et al.		
				5,876,351 A		3/1999	Rohde		
				5,877,675 A		3/1999	Rebstock et al.		
				5,889,730 A		3/1999	May		
				5,929,761 A		7/1999	Van Der Laan et al.		
				D414,870 S		10/1999	Saltzstein et al.		
				5,970,388 A		10/1999	Will		
				5,976,083 A		11/1999	Richardson et al.		
				5,982,297 A		11/1999	Welle		
				5,983,127 A		11/1999	DePinto		
				6,008,703 A		12/1999	Perrott et al.		
				6,024,705 A		2/2000	Schlager et al.		
				6,037,704 A		3/2000	Welle		
				6,047,257 A		4/2000	Dewaele		
				6,048,319 A		4/2000	Hudgins et al.		
				D427,315 S		6/2000	Saltzstein et al.		
				6,072,396 A		6/2000	Gaukel		
				6,083,248 A		7/2000	Thompson		
				6,084,510 A		7/2000	Lemelson et al.		
				6,102,856 A		8/2000	Groff et al.		

(56)

References Cited

U.S. PATENT DOCUMENTS

6,153,532	A	11/2000	Dow et al.	7,548,623	B2	6/2009	Manabe
6,159,147	A	12/2000	Lichter et al.	7,596,405	B2	9/2009	Kurzweil et al.
6,198,394	B1	3/2001	Jacobsen et al.	7,603,148	B2	10/2009	Michalak
6,224,548	B1	5/2001	Gopinathan et al.	7,647,185	B2	1/2010	Tarassenko et al.
6,236,889	B1	5/2001	Soykan et al.	7,654,148	B2	2/2010	Tomlinson, Jr. et al.
6,264,614	B1	7/2001	Albert et al.	7,657,479	B2	2/2010	Henley
6,282,440	B1	8/2001	Brodnick et al.	7,668,589	B2	2/2010	Bauer
6,282,441	B1	8/2001	Raymond et al.	7,689,437	B1	3/2010	Teller et al.
6,289,238	B1	9/2001	Besson et al.	7,701,895	B2	4/2010	Gehasie et al.
6,319,201	B1	11/2001	Wilk	7,733,224	B2	6/2010	Tran
6,343,049	B1	1/2002	Toda	7,742,808	B2	6/2010	Nissila et al.
6,363,139	B1	3/2002	Zurek et al.	7,806,832	B2	10/2010	Gallagher et al.
6,364,834	B1	4/2002	Reuss et al.	7,819,814	B2	10/2010	Gavriely et al.
6,366,871	B1	4/2002	Geva	7,846,104	B2	12/2010	MacQuarrie et al.
6,377,843	B1	4/2002	Naydenov et al.	7,846,106	B2	12/2010	Andrews et al.
6,418,394	B1	7/2002	Puolakanaho et al.	7,904,160	B2	3/2011	Brodnick et al.
6,433,689	B1	8/2002	Hovind et al.	7,945,064	B2	5/2011	O'Brien et al.
6,453,164	B1	9/2002	Fuller et al.	7,946,959	B2	5/2011	Shum et al.
6,478,736	B1	11/2002	Mault	7,955,273	B2	6/2011	Rahe-Meyer
6,485,416	B1	11/2002	Platt et al.	7,983,749	B2	7/2011	Warren
6,507,734	B1	1/2003	Berger et al.	8,019,609	B2	9/2011	Tamir et al.
6,513,532	B2	2/2003	Mault et al.	8,034,006	B2	10/2011	Celik-Butler et al.
6,549,756	B1	4/2003	Engstrom	8,062,090	B2	11/2011	Atsmon et al.
6,558,320	B1	5/2003	Causey, III et al.	8,078,136	B2	12/2011	Atsmon et al.
6,579,231	B1	6/2003	Phipps	8,078,278	B2	12/2011	Penner
6,595,929	B2	7/2003	Stivoric et al.	8,126,526	B2	2/2012	Kitajima et al.
6,600,471	B2	7/2003	Lee et al.	8,126,566	B2	2/2012	Stahmann et al.
6,605,038	B1	8/2003	Teller et al.	8,126,728	B2	2/2012	Dicks et al.
6,612,985	B2	9/2003	Eiffert et al.	8,130,093	B2	3/2012	Mazar et al.
6,616,613	B1	9/2003	Goodman	8,150,750	B2	4/2012	Ray
6,636,761	B2	10/2003	Brodnick	8,160,276	B2	4/2012	Liao et al.
6,685,633	B2	2/2004	Albert et al.	8,165,677	B2	4/2012	Von Arx et al.
6,717,983	B1	4/2004	Toda	8,216,136	B2	7/2012	Addison et al.
6,790,178	B1	9/2004	Mault et al.	8,224,429	B2	7/2012	Prstojevich et al.
6,804,558	B2	10/2004	Haller et al.	8,265,907	B2	9/2012	Nanikashvili et al.
6,820,057	B1	11/2004	Loch et al.	8,275,553	B2	9/2012	Ochs et al.
6,845,263	B2	1/2005	Kawaguchi	8,275,635	B2	9/2012	Stivoric et al.
6,893,396	B2	5/2005	Schulze et al.	8,282,550	B2	10/2012	Rasdal et al.
6,928,535	B2	8/2005	Yamashita et al.	8,285,356	B2	10/2012	Bly et al.
6,950,681	B2	9/2005	Hofmann	8,301,232	B2	10/2012	Albert et al.
6,970,737	B1	11/2005	Brodnick et al.	8,301,236	B2	10/2012	Baumann et al.
6,987,965	B2	1/2006	Ng et al.	8,323,188	B2	12/2012	Tran
7,018,339	B2	3/2006	Birnbaum et al.	8,328,718	B2	12/2012	Tran
7,020,508	B2	3/2006	Stivoric et al.	8,332,233	B2	12/2012	Ott et al.
7,031,745	B2	4/2006	Shen	8,364,250	B2	1/2013	Moon et al.
7,061,381	B2	6/2006	Forcier et al.	8,369,936	B2	2/2013	Farringdon et al.
7,103,407	B2	9/2006	Hjelt et al.	8,374,688	B2	2/2013	Libbus et al.
7,107,095	B2	9/2006	Manolas	8,449,471	B2	5/2013	Tran
7,108,659	B2	9/2006	Ross et al.	8,500,636	B2	8/2013	Tran
7,153,262	B2	12/2006	Stivoric et al.	8,509,882	B2	8/2013	Albert et al.
7,162,294	B2	1/2007	Rowlandson et al.	8,519,835	B2	8/2013	Dunko
7,188,151	B2	3/2007	Kumar et al.	8,543,185	B2	9/2013	Yuen et al.
7,222,054	B2	5/2007	Geva	8,548,770	B2	10/2013	Yuen et al.
7,236,818	B2	6/2007	McLeod et al.	8,700,137	B2	4/2014	Albert
7,257,448	B2	8/2007	Crowe et al.	8,755,871	B2	6/2014	Weng et al.
7,260,429	B2	8/2007	Siejko et al.	8,923,958	B2	12/2014	Gupta et al.
7,261,690	B2	8/2007	Teller et al.	8,951,189	B2	2/2015	Osorio
7,285,090	B2	10/2007	Stivoric et al.	8,951,192	B2	2/2015	Osorio
7,319,425	B2	1/2008	Fiorenza et al.	8,974,396	B1	3/2015	Brady et al.
7,324,836	B2	1/2008	Steenstra et al.	8,977,347	B2	3/2015	Mestha et al.
7,349,574	B1	3/2008	Sodini et al.	9,026,202	B2	5/2015	Albert
7,351,207	B2	4/2008	Priemer	2001/0027384	A1	10/2001	Schulze et al.
7,354,400	B2	4/2008	Asafusa et al.	2001/0031998	A1	10/2001	Nelson et al.
7,382,247	B2	6/2008	Welch et al.	2001/0051766	A1	12/2001	Gazdzinski
7,383,297	B1	6/2008	Atsmon et al.	2002/0016541	A1	2/2002	Glossop
7,398,115	B2	7/2008	Lynn	2002/0032386	A1	3/2002	Sackner et al.
7,415,304	B2	8/2008	Rowlandson et al.	2002/0111556	A1	8/2002	Wegner
7,444,116	B2	10/2008	Ivanov et al.	2002/0143576	A1	10/2002	Nolvak et al.
7,460,899	B2	12/2008	Almen	2003/0004425	A1	1/2003	Narimatsu et al.
7,502,643	B2	3/2009	Farringdon et al.	2003/0093002	A1	5/2003	Kuo
7,509,159	B2	3/2009	Xue et al.	2003/0107487	A1	6/2003	Korman et al.
7,515,043	B2	4/2009	Welch et al.	2003/0117987	A1	6/2003	Brebner
7,515,044	B2	4/2009	Welch et al.	2003/0149344	A1	8/2003	Nizan
7,520,860	B2	4/2009	Guion-Johnson et al.	2003/0193839	A1	10/2003	Singh
7,542,878	B2	6/2009	Nanikashvili	2004/0034284	A1	2/2004	Aversano et al.
				2004/0044292	A1	3/2004	Yasushi et al.
				2004/0059205	A1	3/2004	Carlson et al.
				2004/0117212	A1	6/2004	Kong et al.
				2004/0120356	A1	6/2004	Davenport et al.

(56)

References Cited

U.S. PATENT DOCUMENTS

2004/0143403 A1 7/2004 Brandon et al.
 2004/0215088 A1 10/2004 Hubelbank
 2004/0215094 A1 10/2004 Baumer et al.
 2004/0220487 A1 11/2004 Vyshedskiy et al.
 2004/0220488 A1 11/2004 Vyshedskiy et al.
 2004/0225199 A1 11/2004 Evanyk et al.
 2004/0228217 A1 11/2004 Szeto
 2004/0236819 A1 11/2004 Anati et al.
 2004/0266407 A1 12/2004 Lee et al.
 2004/0266480 A1 12/2004 Hjelt et al.
 2005/0014531 A1 1/2005 Findikli
 2005/0027207 A1 2/2005 Westbrook et al.
 2005/0078533 A1 4/2005 Vyshedskiy et al.
 2005/0124864 A1 6/2005 Mack et al.
 2005/0234353 A1 10/2005 Xue et al.
 2006/0022833 A1 2/2006 Ferguson et al.
 2006/0047215 A1 3/2006 Newman et al.
 2006/0173259 A1 8/2006 Flaherty et al.
 2006/0190045 A1 8/2006 Marcus et al.
 2006/0193270 A1 8/2006 Gehasie et al.
 2006/0252999 A1 11/2006 Devaul et al.
 2007/0021677 A1 1/2007 Markel
 2007/0027386 A1 2/2007 Such et al.
 2007/0032731 A1 2/2007 Lovejoy et al.
 2007/0063850 A1 3/2007 Devaul et al.
 2007/0106179 A1 5/2007 Bagha et al.
 2007/0156060 A1 7/2007 Cervantes
 2007/0254604 A1 11/2007 Kim
 2007/0265038 A1 11/2007 Kim
 2008/0009759 A1 1/2008 Chetham et al.
 2008/0058670 A1 3/2008 Mainini
 2008/0112885 A1 5/2008 Okunev et al.
 2008/0146890 A1 6/2008 LeBoeuf et al.
 2008/0171945 A1 7/2008 Dotter
 2008/0177162 A1 7/2008 Bae et al.
 2008/0198872 A1 8/2008 Pierce
 2008/0214903 A1 9/2008 Orbach
 2008/0228045 A1 9/2008 Gao et al.
 2008/0293453 A1 11/2008 Atlas et al.
 2009/0010461 A1 1/2009 Klinghult et al.
 2009/0024045 A1 1/2009 Prakash et al.
 2009/0037575 A1 2/2009 Crystal et al.
 2009/0117883 A1 5/2009 Coffing et al.
 2009/0144080 A1 6/2009 Gray et al.
 2009/0149767 A1 6/2009 Rossetti
 2009/0156908 A1 6/2009 Belalcazar et al.
 2009/0171170 A1 7/2009 Li et al.
 2009/0209873 A1 8/2009 Pinter et al.
 2009/0273467 A1 11/2009 Elixmann et al.
 2009/0279389 A1 11/2009 Irie
 2009/0287067 A1 11/2009 Dorogusker et al.
 2009/0306485 A1 12/2009 Bell
 2009/0312655 A1 12/2009 Lo
 2010/0027379 A1 2/2010 Saulnier et al.
 2010/0033303 A1 2/2010 Dugan et al.
 2010/0035927 A1 2/2010 Ojika et al.
 2010/0042008 A1 2/2010 Amitai et al.
 2010/0049006 A1 2/2010 Magar et al.
 2010/0049037 A1 2/2010 Pinter et al.
 2010/0063381 A1 3/2010 Greiser
 2010/0069735 A1 3/2010 Berkner
 2010/0076276 A1 3/2010 Gilland
 2010/0094152 A1 4/2010 Semmlow
 2010/0113950 A1 5/2010 Lin et al.
 2010/0148956 A1 6/2010 Song et al.
 2010/0184479 A1 7/2010 Griffin, Jr.
 2010/0204758 A1 8/2010 Boon et al.
 2010/0208434 A1 8/2010 Kim et al.
 2010/0217099 A1 8/2010 Leboeuf et al.
 2010/0217100 A1 8/2010 Leboeuf et al.
 2010/0217345 A1 8/2010 Wolfe et al.
 2010/0234746 A1 9/2010 Sebelius et al.
 2010/0256509 A1 10/2010 Kuo et al.
 2010/0256976 A1 10/2010 Atsmon et al.
 2010/0281261 A1 11/2010 Razzell

2010/0298711 A1 11/2010 Pedersen et al.
 2010/0324378 A1 12/2010 Tran et al.
 2010/0331631 A1 12/2010 MacLaughlin
 2011/0015496 A1 1/2011 Sherman et al.
 2011/0035927 A1 2/2011 Griffin et al.
 2011/0060251 A1 3/2011 Verma et al.
 2011/0066042 A1 3/2011 Pandia et al.
 2011/0117529 A1 5/2011 Barash et al.
 2011/0134725 A1 6/2011 Su et al.
 2011/0160601 A1 6/2011 Wang et al.
 2011/0182445 A1 7/2011 Atsmon et al.
 2011/0208076 A1 8/2011 Fong et al.
 2011/0235466 A1 9/2011 Booij et al.
 2011/0275950 A1 11/2011 Xue et al.
 2011/0288425 A1 11/2011 Stewart
 2011/0301435 A1 12/2011 Albert et al.
 2011/0301439 A1 12/2011 Albert et al.
 2012/0051187 A1 3/2012 Paulson et al.
 2012/0053424 A1 3/2012 Kenalty et al.
 2012/0071734 A1 3/2012 Shimuta et al.
 2012/0101396 A1 4/2012 Solosko et al.
 2012/0108916 A1 5/2012 Riftine
 2012/0123891 A1 5/2012 Patel
 2012/0127833 A1 5/2012 Ghen et al.
 2012/0143018 A1 6/2012 Skidmore et al.
 2012/0147921 A1 6/2012 Conti et al.
 2012/0157019 A1 6/2012 Li
 2012/0158090 A1 6/2012 Chavan et al.
 2012/0171963 A1 7/2012 Tsfaty
 2012/0172689 A1 7/2012 Albert et al.
 2012/0179056 A1 7/2012 Moulder et al.
 2012/0197148 A1* 8/2012 Levitan A61B 5/02405
 600/515
 2012/0285588 A1 11/2012 Sheppard
 2012/0316413 A1 12/2012 Liu et al.
 2013/0003852 A1 1/2013 Yamamoto
 2013/0030259 A1 1/2013 Thomsen et al.
 2013/0085364 A1 4/2013 Lu et al.
 2013/0122810 A1 5/2013 Kaufman
 2013/0156194 A1 6/2013 Tanioka
 2013/0159699 A1 6/2013 Torkkel
 2013/0197320 A1 8/2013 Albert et al.
 2013/0236980 A1 9/2013 Moretti et al.
 2013/0261414 A1 10/2013 Tal et al.
 2013/0289366 A1 10/2013 Chua et al.
 2013/0331663 A1 12/2013 Albert et al.
 2014/0050321 A1 2/2014 Albert et al.
 2014/0066798 A1 3/2014 Albert
 2014/0128758 A1 5/2014 Galloway et al.
 2014/0194760 A1 7/2014 Albert
 2014/0228665 A1 8/2014 Albert
 2014/0276162 A1 9/2014 Albert et al.
 2015/0018660 A1 1/2015 Thomson et al.
 2015/0087952 A1 3/2015 Albert et al.
 2015/0265164 A1 9/2015 Gopalakrishnan et al.
 2015/0297134 A1 10/2015 Albert et al.
 2016/0071392 A1 3/2016 Hankey et al.

FOREIGN PATENT DOCUMENTS

CN 201918016 U 8/2011
 CN 102347804 A 2/2012
 CN 105338892 A 2/2016
 DE 2506936 A1 9/1976
 DE 4212670 A1 1/1994
 EP 0631226 A1 12/1994
 EP 1181888 B1 9/2007
 EP 1238633 B1 10/2008
 EP 2030565 A1 3/2009
 EP 2116183 B1 2/2012
 EP 2986204 A1 2/2016
 FR 2740426 A1 4/1997
 GB 2181554 A 4/1987
 GB 2408105 A 5/2005
 JP S59122032 A 7/1984
 JP S59190742 A 10/1984
 JP S63072231 A 4/1988
 JP S63294044 A 11/1988
 JP H01244328 A 9/1989

(56)

References Cited

FOREIGN PATENT DOCUMENTS

JP	H05167540	A	7/1993
JP	H06-326669	A	11/1994
JP	2002191562	A	7/2002
JP	2002261731	A	9/2002
JP	2003010177	A	1/2003
JP	2005295378	A	10/2005
JP	2012065073	A	3/2012
KR	20100059198	A	6/2010
MX	2009011781	A	5/2011
WO	WO-8200910	A1	3/1982
WO	WO-8805282	A1	7/1988
WO	WO-9008361	A1	7/1990
WO	WO-9206551	A1	4/1992
WO	WO-9731437	A1	8/1997
WO	WO-9838611	A1	9/1998
WO	WO-9944494	A1	9/1999
WO	WO-0041620	A1	7/2000
WO	WO-0147597	A2	7/2001
WO	WO-0157619	A2	8/2001
WO	WO-02080762	A1	10/2002
WO	WO-03075118	A2	9/2003
WO	WO-03094720	A1	11/2003
WO	WO-2004037080	A1	5/2004
WO	WO-2006001005	A2	1/2006
WO	WO-2006021956	A2	3/2006
WO	WO-2007014545	A2	2/2007
WO	WO-2007088315	A1	8/2007
WO	WO-2008005015	A1	1/2008
WO	WO-2008066682	A2	6/2008
WO	WO-2010025166	A1	3/2010
WO	WO-2010099066	A2	9/2010
WO	WO-2010108287	A1	9/2010
WO	WO-2010113354	A1	10/2010
WO	WO-2010144626	A1	12/2010
WO	WO-2011006356	A1	1/2011
WO	WO-2011008838	A1	1/2011
WO	WO-2011014292	A1	2/2011
WO	WO-2011022942	A1	3/2011
WO	WO-2011040877	A1	4/2011
WO	WO-2011040878	A1	4/2011
WO	WO-2011113070	A1	9/2011
WO	WO-2011137375	A2	11/2011
WO	WO-2011156374	A2	12/2011
WO	WO-2012046158	A1	4/2012
WO	WO-2012108895	A1	8/2012
WO	WO-2012129413	A1	9/2012
WO	WO-2012160550	A1	11/2012
WO	WO-2013028960	A1	2/2013
WO	WO-2013036307	A1	3/2013
WO	WO-2013066642	A1	5/2013
WO	WO-2013093690	A1	6/2013
WO	WO-2013122788	A1	8/2013
WO	WO-2013138500	A1	9/2013
WO	WO-2013155196	A2	10/2013
WO	WO-2013192166	A1	12/2013
WO	WO 2014/172451		10/2014

OTHER PUBLICATIONS

Australian Design Awards. Heartplus Micro; printed from website <http://www.designawards.com/au>; printed on Apr. 12, 2002. 6 pages.

Bajaj, M.D.; "Event Recording in Ambulatory Patients with Syncope Events"; University of Kansas; Wichita, Kansas; (no date); pp. 15-18; printed on or before Apr. 14, 2010.

Bluetooth. Headset Profile (HSP), printed from website <http://bluetooth.com/English/Technology/Works/Pates/HSP.aspx>, printed on May 12, 2010.

Bramanti et al., Multichannel telemetric system for biomedical signals via switched telephone lines, *Medical and Biological Engineering and Computing*, Sep. 1982, vol. 20, No. 5, pp. 653-656.

Burke, "A Micropower Dry-Electrode ECG Preamplifier", *IEEE Transactions on Biomedical Engineering*, Feb. 2000, vol. 47, No. 2, pp. 155-162.

Card Guard CG-6108 ACT Ambulatory Cardiac Telemetry Brochure; Card Guard; The Telemedicine Company; Switzerland; 2006; 2 pages.

Cardiocomm Solutions; GEMS AIR. (PC based ECG management) printed from website <http://www.cardiocommsolutions.com>; printed on Mar. 19, 2010; 1 page.

Charuvastra. Transtelephonic Cardiac Event Recording for Arrhythmia Surveillance; printed from website <http://tchin.org/resource-room/c-art>. printed on Mar. 26, 2010. 2 pages.

Cheng, Allen C.; "Real-Time Cardiovascular Diseases Detection on a Smartphone"; Departments of Electrical and Computer Engineering, Bioengineering, Neurological Surgery and Computer Science; University of Pittsburgh; Pittsburgh, PA; printed on or before Apr. 14, 2010.

Co-pending U.S. Appl. No. 14/692,563, filed Apr. 21, 2015.

Co-pending U.S. Appl. No. 14/730,122, filed Jun. 3, 2015.

Co-pending U.S. Appl. No. 61/800,879, filed Mar. 15, 2013.

Co-pending U.S. Appl. No. 61/872,555, filed Aug. 30, 2013.

Co-pending U.S. Appl. No. 61/874,806, filed Sep. 6, 2013.

Co-pending U.S. Appl. No. 61/915,113, filed Dec. 12, 2013.

Creative. PC-80B Portable ECG Monitor w/sd card extension slot; printed from website www.amazon.com/Portable-Monitor-extension-leather-shipping/dp/B0010jWKUE; printed on Feb. 4, 2010. 5 pages.

Deveau, "Health Care eyes smart phones to heal ills"; printed from the website <http://www.theQiobeandmail.com> on Sep. 17, 2009, 4 pages.

Dinh. Heart activity monitoring on smartphone. IPCBEE-Int conf Biomedical Eng and Technol. Jun. 17-19, 2011. 11:45-49.

Dobrev, et al., Bootstrapped two-electrode biosignal amplifier, *Med Bio Eng Comput*, 2008, 7 pages.

Dolan; Qualcomm launches ECG smartphone program in China; Sep. 8, 2011; 11 pgs.; retrieved Mar. 19, 2014 from the internet (<http://mobihealthnews.com/13092/qualcomm-launches-ecg-smartphone-program-in-china/>).

Elert, Glenn (Editor); *Frequency Range of Human Hearing*; The Physics Factbook; web version as of Mar. 29, 2010; 2 pgs.; printed Jun. 6, 2012 (<http://web.archive.org/web/20100329141847/http://hypertextbook.com/facts/2003/ChrisDAmbrose.shtml>).

European search report and opinion dated Nov. 21, 2014 for EP Application No. 11865699.0.

Favorite Plus. Handheld ECG Monitor—Handheld Easy EKG Monitor; printed from website www.favoriteplus.com/easy-ecg-handheld-monitor-fp; printed on Feb. 4, 2010; 2 pages.

Favorite Plus. Handheld ECG Monitor—Handheld EKG Monitor at Favoriteplus.com; printed from website www.favoriteplus.com/handheld-ecg-ekg-monitor; printed on Feb. 4, 2010; 3 pages.

Favorite Plus. Handheld ECG Monitor—Handheld EKG Monitor InstantCheck; printed from website <http://www.favoriteplus.com/instantcheck-hand-held-ecg-ekg-monitor>; printed on Feb. 4, 2010; 2 pages.

Ferrick, M.D.; "Holter Monitoring and cardiac Event Recording in Assessing Symptomatic Patients"; Albert Einstein College of Medicine; Bronx, New York; (no date) pp. 11-14. printed on or before Apr. 14, 2010.

FREE2MOVE. Vitaphone 2300; www.free2move.us/News/NewsVitaphone240105.htm printed May 12, 2010.

Fulford-Jones, et al., "A Portable Low-Power, Wireless Two-Lead EKG System", Division of Engineering and Applied Sciences, Harvard University, Sep. 2004, 4 pages.

Garabelli et al. Accuracy and Novelty of an Inexpensive iPhone-based Event Recorder (Presented Poster/Abstract) Heart Rhythm 2012, 23rd Annual Scientific Session. SP23. Innovation Poster Session II. No. IA02-1; May 11, 2012.

GBI PORTAL. Qualcomm's wireless reach mHealth project to improve cardiovascular disease in resource scarce China; Feb. 17, 2012; 7 pgs. Retrieved Mar. 19, 2014 from www.intergrall.com/2012/02/17/qualcooma-wireless-reach-mhealth-project-to-improve-cardiovascular-disease-in-resource-scarce-china/.

GE; Healthcare., "Marquette heart rate turbulence analysis program", 2005, DC-0160-12.05-EN-US. 4 pages.

(56)

References Cited

OTHER PUBLICATIONS

- Gillette, M.D.; "Diagnosis of Pediatric Arrhythmias with Event Recording"; Medical University of South Carolina; Charleston, South Carolina; (no date); pp. 25-32; printed on or before Apr. 14, 2010.
- Grier, James W.; "How to use 1-lead ECG recorders to obtain 12-lead resting ECGs and exercise ("stress") ECGs"; Department of Biological Sciences; printed from website <http://www.ndsu.edu/pubweb/rvgrier/>; printed on 06/07/21010; 13 pages.
- Hannaford, Kat; "How to Turn Your iPhone Into a Laser, Fan or Flashlight"; printed from website <http://m.qizmodo.com/5534904>; printed on Feb. 3, 2011.
- Hartmann, "ECG Front-End Design is Simplified with MicroConverter" Analog Dialogue, Nov. 2003, vol. 37, pp. 1-5.
- Hayes, M.D.; "Approaches to Diagnosing Transient Arrhythmias" An Overview; Mayo Clinic; Rochester Minnesota; (no date); pp. 7-10; printed on or before Apr. 14, 2010.
- Hearing Loss Assoc. of Kentuckiana; Decibel Ratings/Hazardous Time Exposures of Common Noise (excerpt from Survivor's Manual); web version as of Oct. 5, 2008; 2 pgs.; printed Jun. 6, 2012 (<http://web.archive.org/web/20081005143856/http://www.hearinglossky.org/hlasurvival1.html>).
- Huang, Tina; Age-related hearing loss; Minnesota Medicine; 90(10); pp. 48-50; Oct. 2007; printed Jun. 6, 2012 from: <http://www.minnesotamedicine.com/PastIssues/PastIssues2007/October2007/CiicalHuangOctober2007.aspx>.
- IMEC News; IMEC extends flexible ECG patch to enable arrhythmia detection; printed from website <http://www2.imec.be/imec/> printed on Aug. 18, 2009 1 page.
- INSTROMEDIX. Cardiac Event Recording FAQ's; Instromedix A Card Guard Company, San Diego, CA.; printed from website www.instromedix.com/pdf/products/cardiac; printed on or before Apr. 14, 2010.
- INSTROMEDIX. The Arrhythmia Monitoring System; King of Hearts Express AF Recorder Brochure from Instromedix. A CardGuard Company; Rosemont IL; 2004. 3 pages.
- "International search report and written opinion dated Apr. 30, 2015 for PCT/US2014/070170".
- International search report and written opinion dated Feb. 12, 2015 for PCT Application No. US2014/054414.
- International search report and written opinion dated Feb. 17, 2012 for PCT/US2011/039445.
- International search report and written opinion dated Apr. 27, 2012 for PCT/US2011/053708.
- International search report and written opinion dated May 15, 2013 for PCT/US2013/023370.
- International search report and written opinion dated Dec. 17, 2013 for PCT/US2013/055458.
- International search report dated Sep. 1, 2014 for PCT/US2014/034350.
- Jenkins II, W.; Time/Frequency Relationships for an FFT-Based Acoustic Modem; Naval Postgraduate School; pp. 1-1 02; Sep. 2010 (http://edocs.nps.edu/npspubs/scholarly/theses/2010/Sep/1_OSep_Jenkins.pdf) printed Oct. 2, 2013.
- Kim, et al., "Detection of Atrial Fibrillation Episodes using Multiple Heart Rate Variability Features in Different Time Periods", 2008, 4 pages.
- Koerner. The Author's Metrics; Wired Magazine Article; New York, NY; Jul. 2009; p. 93-126.
- Kumar, M.D., "Zio Patch", printed from website <http://www.irhythmtech.com/zio-solution/zio-gach/>; printed on Apr. 12, 2010.
- Kumarak, Greg; "Visa officially announces their case that turns your iPhone into a credit card (and we've got pies!)" May 17, 2010; printed from website www.mobilecrunch.com printed on Feb. 3, 2011.
- Lau, et al. iPhone ECG application for community screening to detect silent atrial fibrillation: A novel technology to prevent stroke. Int J Cardiol. Apr. 30, 2013;165(1):193-4.
- Lau, et al. Performance of an Automated iPhone ECG Algorithm to Diagnose Atrial Fibrillation in a Community AF Screening Program (Search-AF). Heart, Lung and Circulation. 2013; 22:S205.
- Lau et al. Validation of an iPhone ECG application suitable for community screening for silent atrial fibrillation—A novel way to prevent stroke (Presentation Abstract 16810); American Heart Association 2012 Scientific Sessions and Resuscitation Science Symposium; 126(1); Nov. 20, 2012.
- Leijdekkers et al., "Trial Results of a Novel Cardiac Rhythm Management System using Smart Phones and wireless ECG Sensors", Proceedings of the th International Con. on Smart homes and health Telematics., Jul. 1-3, 2009, Tours, France.
- Levkov et al., "Removal of power-line interference from the ECG: a review of the subtraction procedure" BioMedical Engineering Online 2005, printed from website <http://www.biomedical-engineeringonline.com/content/4/1/50> pp. 1-18.
- Lin; et al., "An intelligent telecardiology system using a wearable and wireless ECG to detect atrial fibrillation.", May 2010, 14(3), 723-33.
- Lowres, et al. Screening Education and Recognition in Community Pharmacies of Atrial Fibrillation to prevent stroke in a ambulant population aged >=65 years (Search-AF stroke prevention study); a cross-sectional study protocol. BMJ Open Jun. 25, 2012; 2(3); pii: e001355. doi: 10.1136/bmjopen-2012-001355.
- M MED Choice. Handheld ECG Monitor Brochure; M Med Choice, Beijing Choice Electronic Technology Co., LTD. published on or before Apr. 14, 2010.
- M MED Choice. Handheld ECG Monitor MD100A1; printed from website <http://www.choicemed.com/products/show.asp>; printed on Dec. 28, 2009; 2 pages.
- M MED Choice. Handheld ECG Monitor MD100B; printed from website <http://www.choicemed.com/products/show.asp>; printed on Dec. 28, 2009. 2 pages.
- M Med Choice printed from website <http://www.choicemed.com/1xwm.asp>; printed on Dec. 28, 2009. 1 page.
- MacFarlane, et al. Resting 12-lead ECG electrode placement and associated problems; SCST update 1995; 15pgs. Printed Feb. 18, 2014 from www.scst.org.uk/resources/RESTING_12.pdf.
- Mauvila ECG Tutorial; Basic ECG Interpretation Tutorial; Sections 1-12; printed from website <http://mauvila.com/ECG/ecg.htm>. printed on Mar. 26, 2010. 56 pages.
- Medgadget. Zio Patch Wins Medical Design Award MedGadget internet journal of emerging medical technologies, printed from website http://medaadaet.com/archives/2010/04/zio_patch_wins_medical_design_award_1.html.
- MiCardioMobile; Remote Wireless Cardiac Rehabilitation Monitoring printed from website <http://alivetec.cable.nu/cardiomobile>. printed on or before Apr. 14, 2010.
- Mobility Mind. Use your Treo 650 as a portable ECG monitoring device, Mobility Mind Celebrating mobile Internet lifestyle and culture, Sep. 14, 2005, printed from website <http://www.treotoday.net/2005/09/14-use-your-treo-650-as-a-portable-ecg-monitoring-device/>.
- Modem Protocols Explained; <ftp://kermit.columbia.edu/kermit/cu/protocol.html>; 5 pgs.; printed Oct. 2, 2013.
- Modem Tutorial; <http://www.Isu.edu/OCS/its/unix/tutorial/ModemTutorial/ModemTutorial.html>; 2 pgs.; printed Oct. 2, 2013.
- Muench, Frederick, PhD; "HRV: The Manufacturers and Vendors Speak; The portable StressEraser Heart Rate Variability Biofeedback Device: Background and Research". Biofeedback vol. 36 Issue 1, pp. 35-39. published Spring 2008.
- Murph. RedEye mini converts iPhone, iPad or iPod touch into IR-beaming universal remote; printed from website <http://www.engadget.com/2010/03/02/redeye/>; printed on Mar. 2, 2010; 3 pages.
- Nam et al.; An Ultrasonic Sensor Based Low-Power Acoustic Modem for Underwater Communication in Underwater Wireless Sensor Networks; Computer Network Lab, Dept. of Elec. Eng., Korea Univ.; pp. 494-504; Dec. 2007. (http://nesl.ee.ucla.edu/fw/torres/home/Dropbox/good_paper_mico_controller.pdf); 11 pgs.; printed Oct. 2, 2013).
- Neuroreille; Audiometry; web version as of Oct. 14, 2008; 1 pg.; printed Jun. 6, 2012 (<http://www.neuroreille.com/promenade/english/audiometry/audiometry.htm>).

(56)

References Cited

OTHER PUBLICATIONS

- New Professional Quality ECG/EKG Portable Heart Monitor; printed from website <http://cgibay.com/ws/eBayISAPI.dll>. printed on Feb. 4, 2010. 3 pages.
- Notice of allowance dated Jan. 8, 2014 for U.S. Appl. No. 14/015,303.
- Notice of allowance dated Jan. 27, 2014 for U.S. Appl. No. 14/015,303.
- Notice of allowance dated Feb. 26, 2014 for U.S. Appl. No. 14/015,303.
- Notice of allowance dated May 23, 2014 for U.S. Appl. No. 13/108,738.
- Notice of allowance dated Jul. 9, 2013 for U.S. Appl. No. 12/796,188.
- Notice of allowance dated Aug. 28, 2012 for U.S. Appl. No. 13/420,520.
- Notice of allowance dated Dec. 4, 2013 for U.S. Appl. No. 14/015,303.
- Office action dated Jan. 2, 2014 for U.S. Appl. No. 13/108,738.
- “Office action dated May 18, 2015 for U.S. Appl. No. 13/752,048.”
- Office action dated Jun. 18, 2012 for U.S. Appl. No. 13/420,520.
- Office action dated Sep. 12, 2014 for U.S. Appl. No. 13/108,738.
- Office action dated Oct. 6, 2014 for U.S. Appl. No. 14/252,044.
- Office action dated Oct. 29, 2012 for U.S. Appl. No. 12/796,188.
- Office action dated Nov. 19, 2014 for U.S. Appl. No. 13/969,446.
- Omron Portable ECG EKG Handheld HCG-801 Monitor; printed from website <http://www.amazon.com/Omron-Portable-Handheld-HCG-801-Monitor/dp/B0019WH3EO> printed on Feb. 24, 2010. 5 pages.
- Omron Portable ECG Monitor; printed from website <http://www.target.com/gp/detail.html>; printed on Mar. 26, 2010. 1 page.
- Oresko, et al., “Detecting Cardiovascular Diseases via Real-Time Electrocardiogram Processing on a Smartphone”, 2009 Workshop on Biomedicine in Computing: Systems, Architectures, and Circuits, pp. 13-16.
- Perez, Sarah; No NFC? No Problem; New Startup Zoosh Provides Workaround Technology (Jun. 20, 2011); printed on or before Jun. 27, 2011 from website; 2 pgs.; (<http://www.readwriteweb.com/archives/>).
- Prystowsky, M.D.; “Chairmans Introduction”; Duke University Medical Center; Indianapolis, Indiana. (no date). pp. 5-6. printed on or before Apr. 14, 2010.
- Prystowsky, M.D.; “Chairmans Summary”; Duke University Medical Center; Indianapolis Indiana; (no date); pp. 39-40. printed on or before Apr. 14, 2010.
- Prystowsky, M.D., “The Clinical Application, Diagnostic Yield and Cost Considerations of Cardiac Event Recorders”, Indianapolis, Indiana (no date) pp. 19-23. printed on or before Apr. 14, 2010.
- Puurtinen, et al., Best Electrode Locations for a Small Bipolar ECG Device: Signal Strength Analysis of Clinical Data, *Annals of Biomedical Engineering*, vol. 37, Nos. 2, Feb. 2009 (© 2008) pp. 331-336.
- Raju Heat-Rate and EKG Montior and EKG Monitor Using the MSP430FG439, SLAA280-Oct. 2005-Revised Sep. 2007, 11 pages. READ-My-HEART. ECG Machine Handheld Read MyHeart; (product item No. HH-3413) printed from website <http://www.helioliving.com/ECH-Machi ne-Handheld-ReadMyHeart>; printed on Feb. 4, 2010; 1 page.
- Readmyheart Personal Handheld ECG Monitor with Free Illustration Book & Free Electrodes V2.2; printed from website <http://www.amazon.com/Readmyheart-Personal-Handheld-illustrator-Electrodes/dp/B0010AN63W>; printed on Mar. 26, 2010; 4 pages.
- Ricker. Square payment dongle demoed for iPhone totting hippies and you (video); printed from website <http://www.engadget.com/2010/01/18/square-payment>; print on Jan. 18, 2010; 6 pages.
- Rockwood. The Networked Body Magazine Article from FAST TALK Magazine Jul./Aug. 2009; pp. 19-26.
- Salahuddin, et al., “Ultra Short Term Analysis of Heart Rate Variability using Normal Sinus Rhythm and Atrial Fibrillation ECG Data”, *Engineering in Medicine and Biology Society*, Aug. 2007, pp. 4656-4659.
- Saxon, et al. iPhone rhythm strip—the implications of wireless and ubiquitous heart rate monitoring. *JACC*; 59(13): E726; Mar. 2012.
- Saxon. Ubiquitous Wireless ECG Recording: A Powerful Tool Physicians Should Embrace. *J Cardiovasc Electrophysiol*. 24(4): pp. 480-483; Apr. 2013.
- Semler, M.D.; “The Future of Cardiac Event Monitoring”; St. Vincent Hospital and Medical Center; Portland Oregon; (no date); pp. 33-37; printed on or before Apr. 14, 2010.
- SFO Medical. Choice Portable Handheld ECG EKG Monitor; printed from website <http://www.amazon.com/Choice-Portable-Handheld-ECG-Monitor/dp/B001Q74VOM>; printed on Mar. 26, 2010; 1 page.
- Shenzhen New Element Med. Equipment. Wireless ECG Monitoring System, printed from website http://www.alibaba.com/product-gs/248168581/Wireless_ECG_Monitoring_system.html, printed on Mar. 26, 2010.
- Shumaker, J.; Designing an Ultrasonic Modem for Robotic Communications; Army Research Laboratory; 26 pgs.; Mar. 2009 (<http://www.dtic.mil/cgi-bin/GetTRDoc?AD=ADA499556>) printed Oct. 2, 2013.
- Smith. Smartphone may keep the cardiologist away, *The Independent. Health & Families*, Mar. 5, 2010, printed from website <http://www.independent.co.uk/life-style/health-and-families/healthnews/smartphone-may-keep-the-cardiologist-away-1916652.html>, printed on Mar. 26, 2010.
- Stevens, “Apple’s Seamlessly Embedded Heart Rate Monitor could turn the iPhone into a new-age mood ring”, printed from the website <http://www.enaadaet.com> on May 6, 2010, 3 pages.
- Taleb Medical. Observer Hand-held ECG Monitor MD100B; (no date); printed on or before Apr. 14, 2010.
- Tei, et al., New index of combined systolic and diastolic myocardial performance: a simple and reproducible measure of cardiac function—a study in normals and dilated cardiomyopathy; *J Cardiol.*; 26(6):357-366; Dec. 1995.
- Texas Instruments. Information for Medical Applications, “Biophysical Monitoring-Electrocardiogram (ECG) Front End”, Apr. 2004, 2 pages.
- Tschida. Power A’s New Case Turns Your iPhone Into A Universal Remote; printed from website <http://appadvice.com/appnn>; printed on Mar. 1, 2010. 2 pages.
- U.S. Appl. No. 13/752,048, filed Jan. 28, 2013.
- U.S. Appl. No. 13/964,490, filed Aug. 12, 2013.
- U.S. Appl. No. 13/969,446, filed Aug. 16, 2013.
- U.S. Appl. No. 14/015,303, filed Aug. 30, 2013.
- U.S. Appl. No. 14/217,032, filed Mar. 17, 2014.
- U.S. Appl. No. 14/252,044, filed Apr. 14, 2014.
- U.S. Appl. No. 14/254,310, filed Apr. 16, 2014.
- U.S. Appl. No. 14/328,962, filed Jul. 11, 2014.
- U.S. Appl. No. 14/479,105, filed Sep. 5, 2014.
- U.S. Appl. No. 14/494,191, filed Sep. 23, 2014.
- Vanhemert, Kyle; “XWave Headset Lets You Control iPhone Apps With Your BRAIN”; Sep. 8, 2010; printed from website <http://gizmodo.com>; printed on Sep. 8, 2010.
- Vitaphone. Telemedicine since 1999: Modern health management is our special subject. 3 pgs. Retrieved Mar. 19, 2014 from www.vitaphone.de/en/company/history-of-vitaphone/.
- Wikimedia Laboratories; Acoustics; web archive version dated Jan. 25, 2009; 2 pgs.; printed Jun. 6, 2012 (<http://liveweb.archive.org/http://en.labs.wikimedia.org/wiki/Acoustics>).
- Wikipedia; Aliasing; web version as of Apr. 3, 2011; 5 pgs.; printed Jun. 6, 2012 (<http://liveweb.archive.org/http://en.wikipedia.org/w/index.php?title=Aliasing&oldid=422141882>).
- Wikipedia; Hearing Range; web version as of Feb. 6, 2010; 5 pgs.; printed Jun. 6, 2012 (http://web.archive.org/web/20100206213741/http://en.wikipedia.org/wiki/Hearing_range).
- Wikipedia. “Pulse oximetry”, printed from website <http://en.wikipedia.org> on May 10, 2010, 4 pages.
- Wisneski, C.; Ultrasonic Local Area Communication; <http://alummi.media.mit.edu/~wiz/ultracom.html>; 2 pgs.; printed Oct. 2, 2013.

(56)

References Cited

OTHER PUBLICATIONS

Woodward et al; "Bio-Potential-To-Frequency Converter/Modulator"; Electronic Design. Aug. 1999. p. 117.

Ziegler, Chris; "EPI Life phone sports ECG function, can let doctors know if you're gonna make it"; printed from website www.enoadoet.com/2010/06/; Jun. 17, 2010.

Chinese Patent Application No. 2013800135500 First Office Action dated Oct. 20, 2015.

International preliminary report on patentability dated Jul. 29, 2014 for PCT/US2013/023370.

International search report dated Dec. 10, 2013 for PCT/US2013/057576.

U.S. Appl. No. 13/964,490 Office Action dated Dec. 21, 2015.

U.S. Appl. No. 14/730,122 Office Action dated Feb. 24, 2016.

PCT/US2014/054414 International Preliminary Report on Patentability mailed Mar. 17, 2016.

* cited by examiner

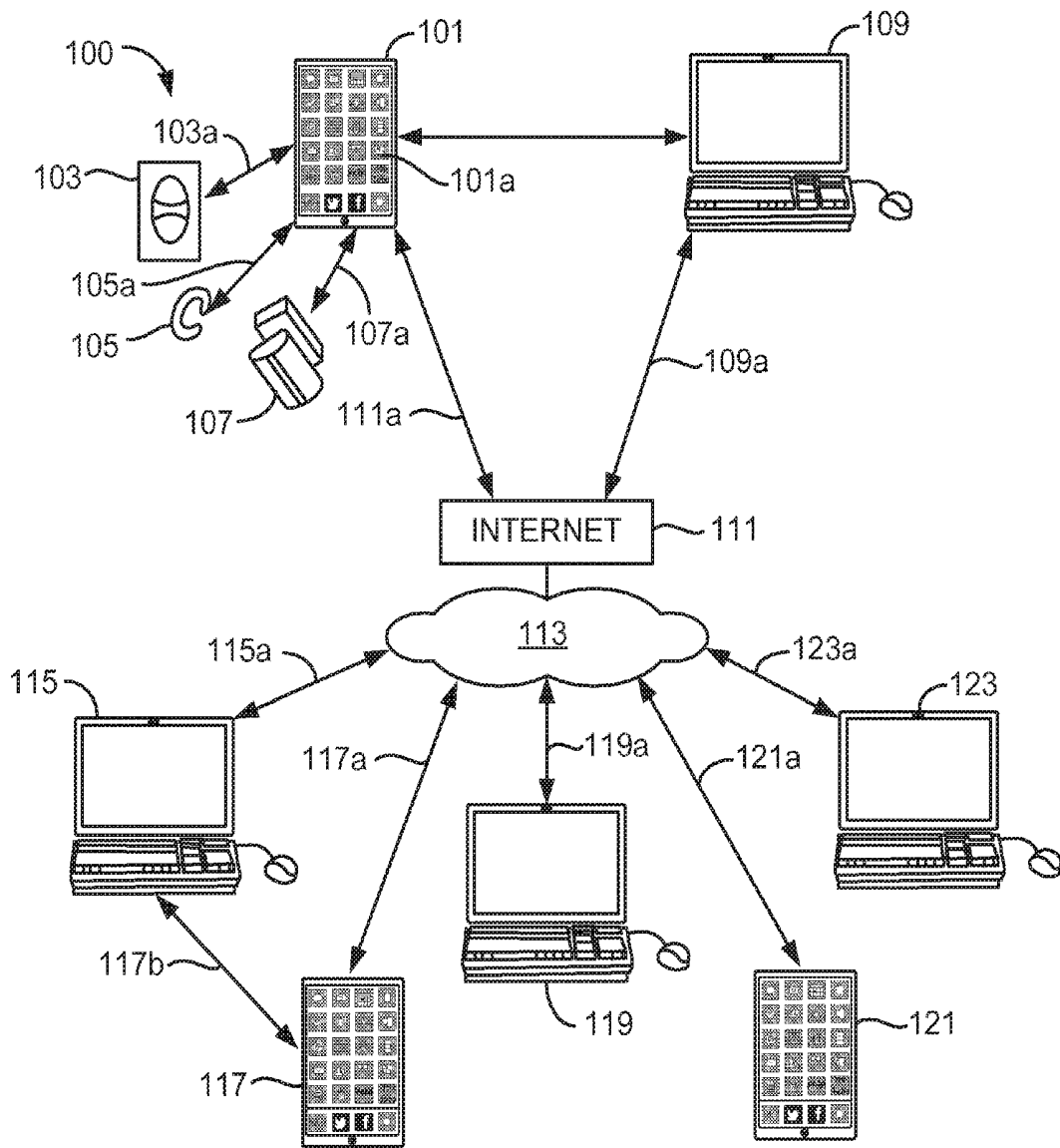

FIG. 1

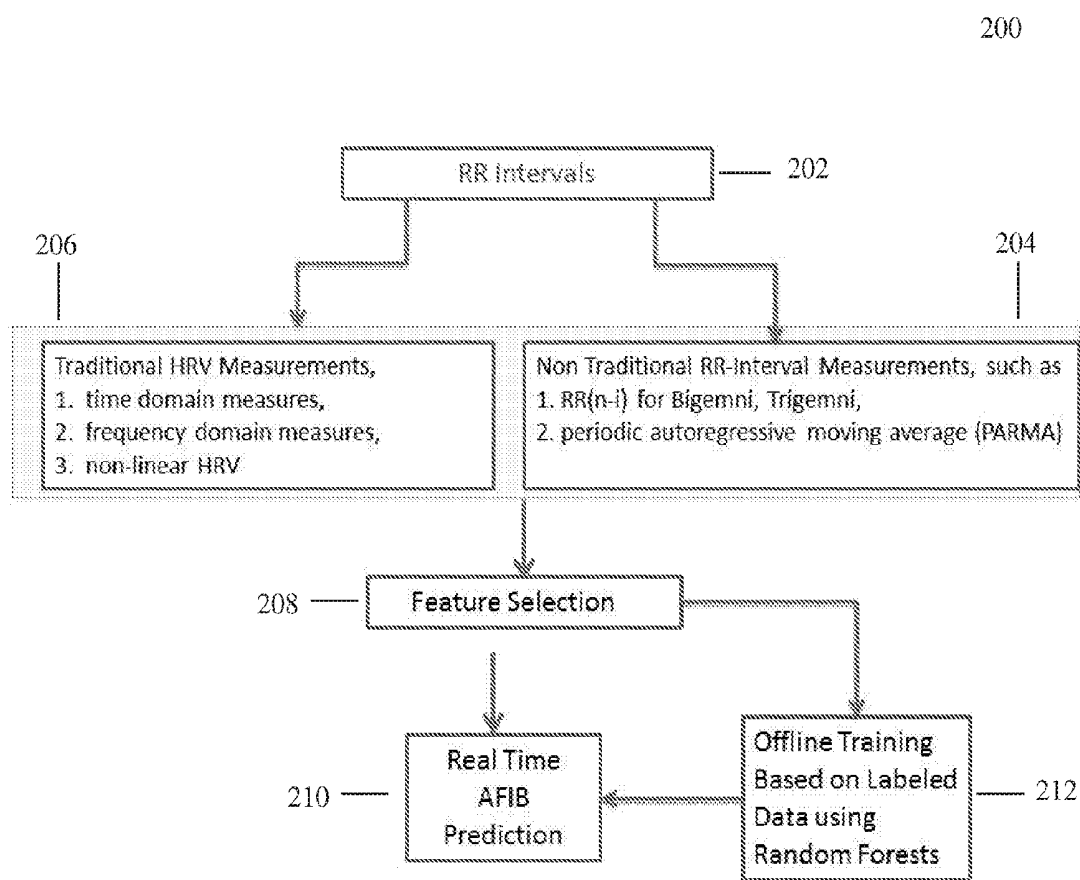

FIG. 2

300

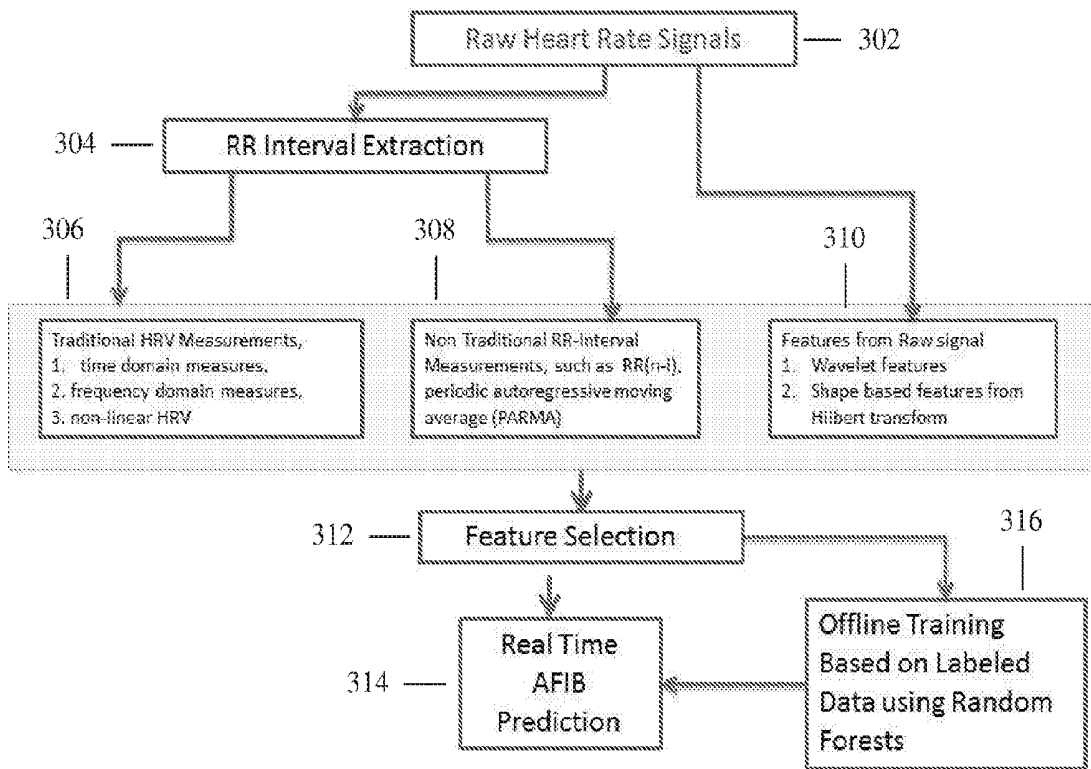

FIG. 3

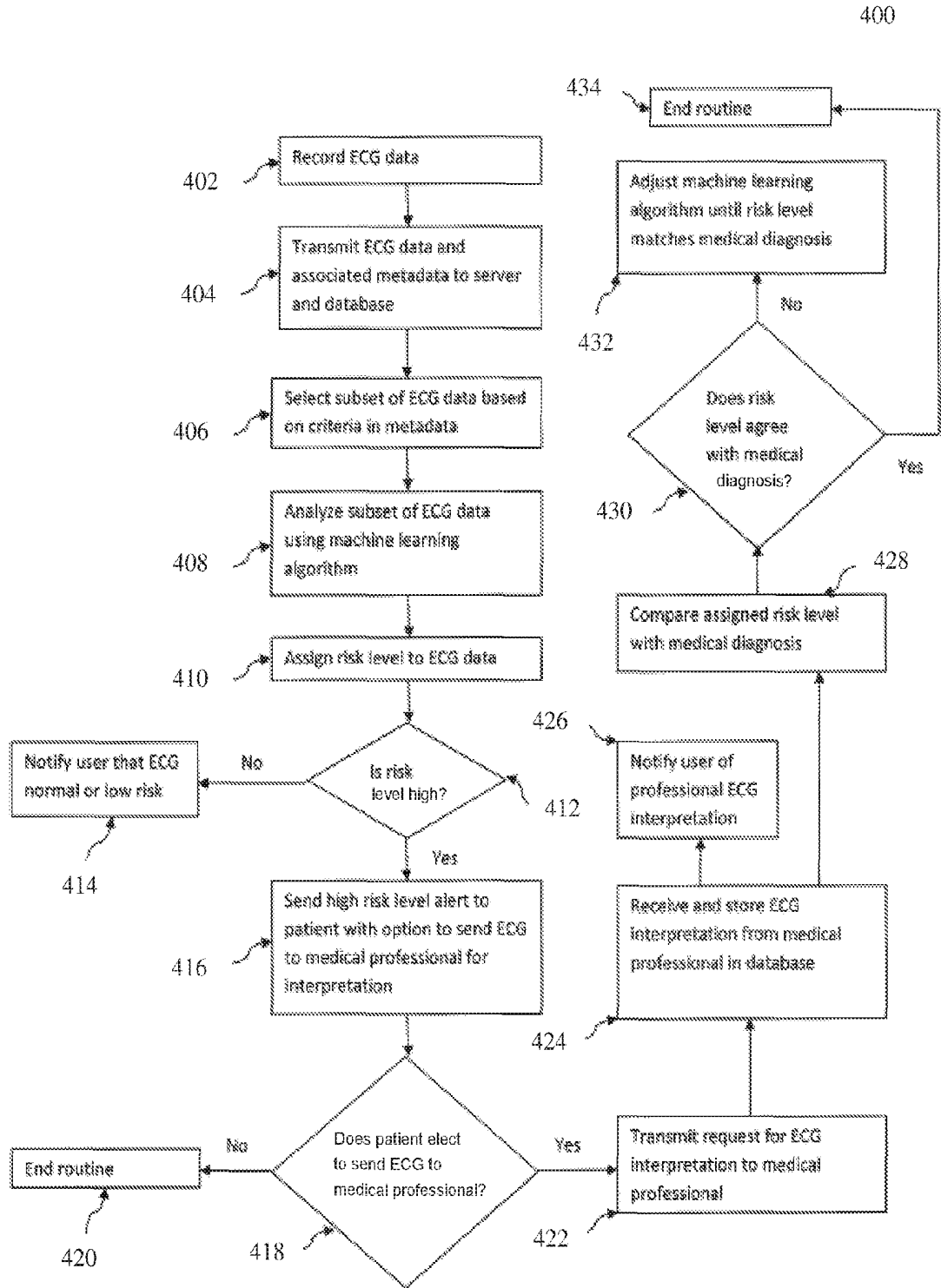

FIG. 4

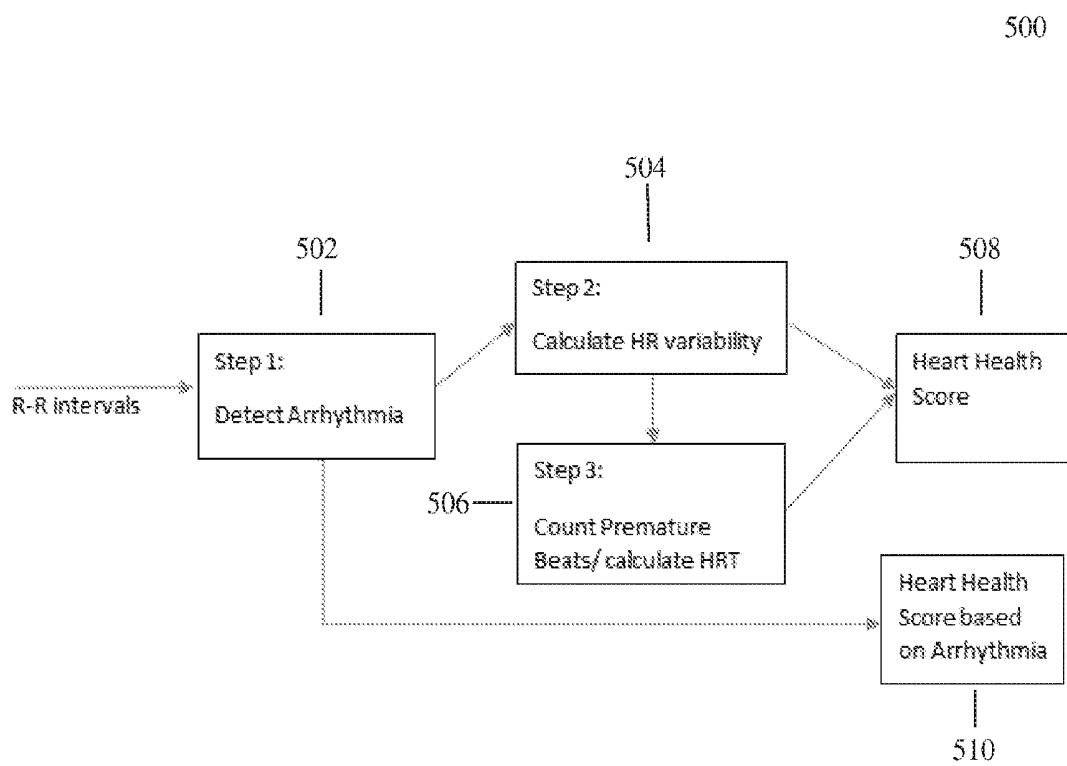

FIG. 5

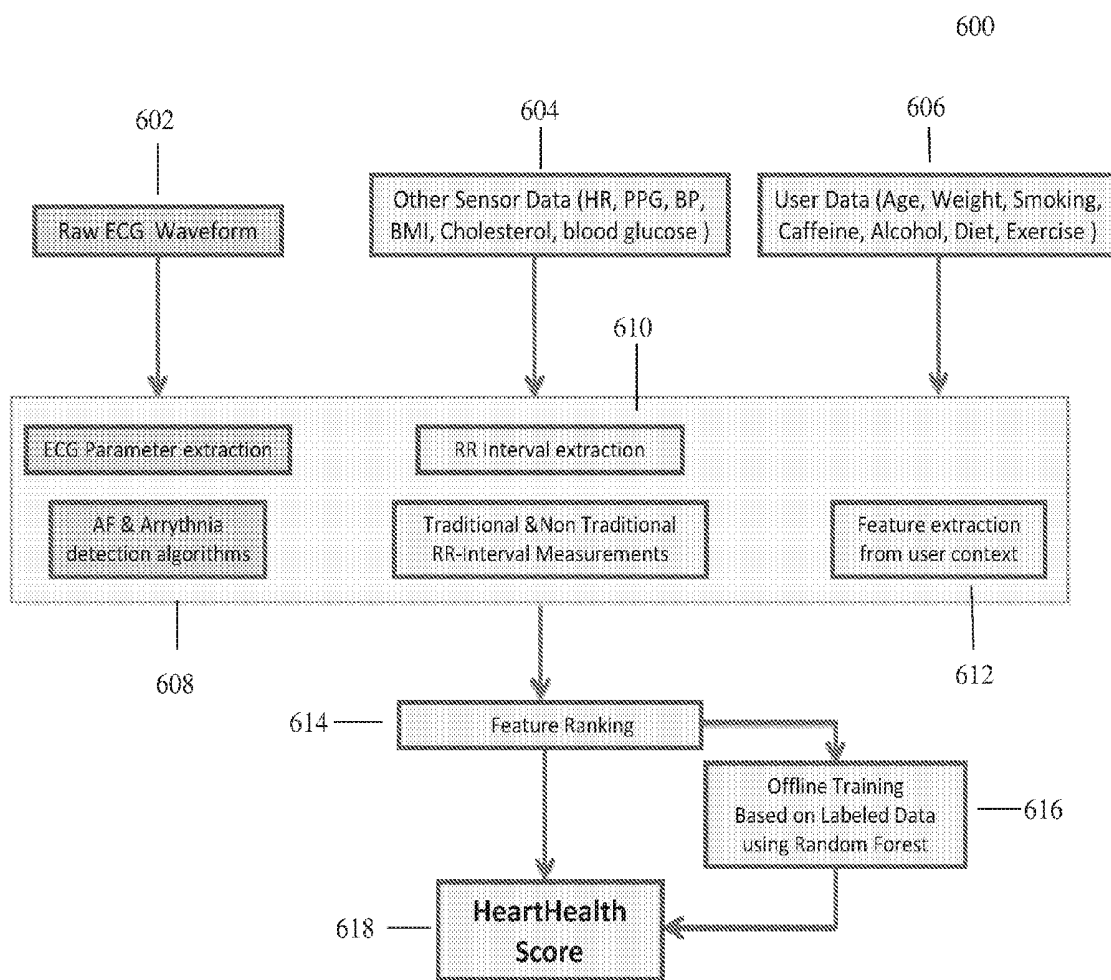

FIG. 6

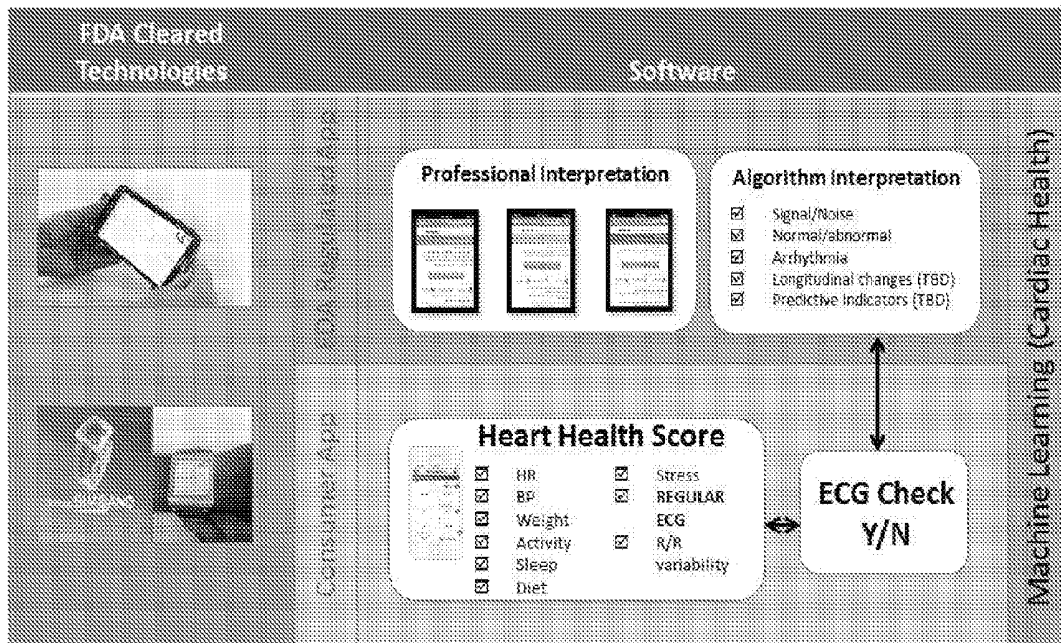

FIG. 7

Consumer Application transition to Medical Application

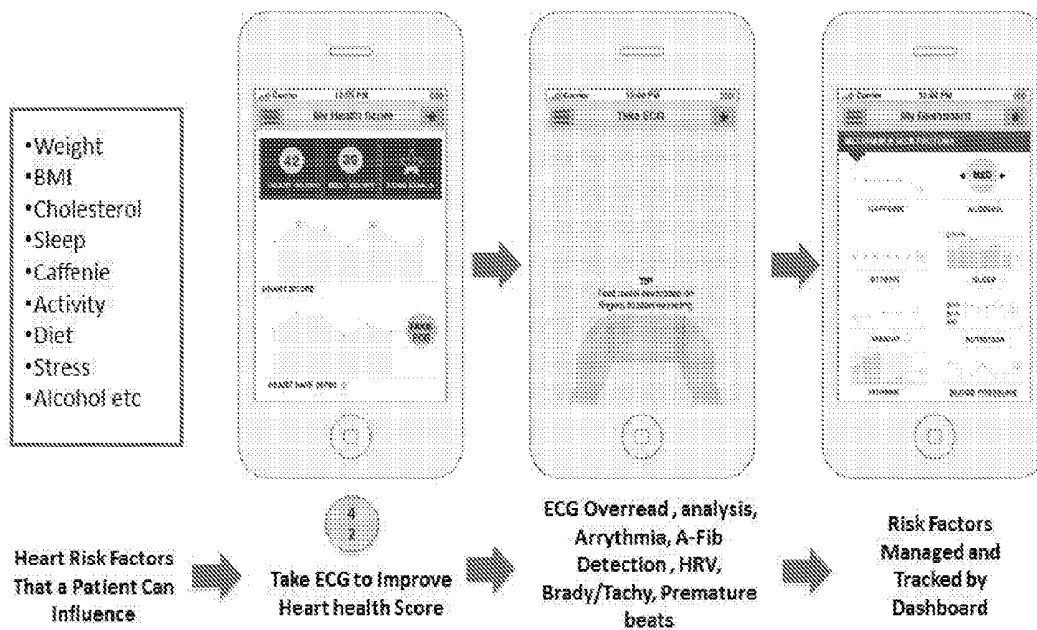

FIG. 8

900

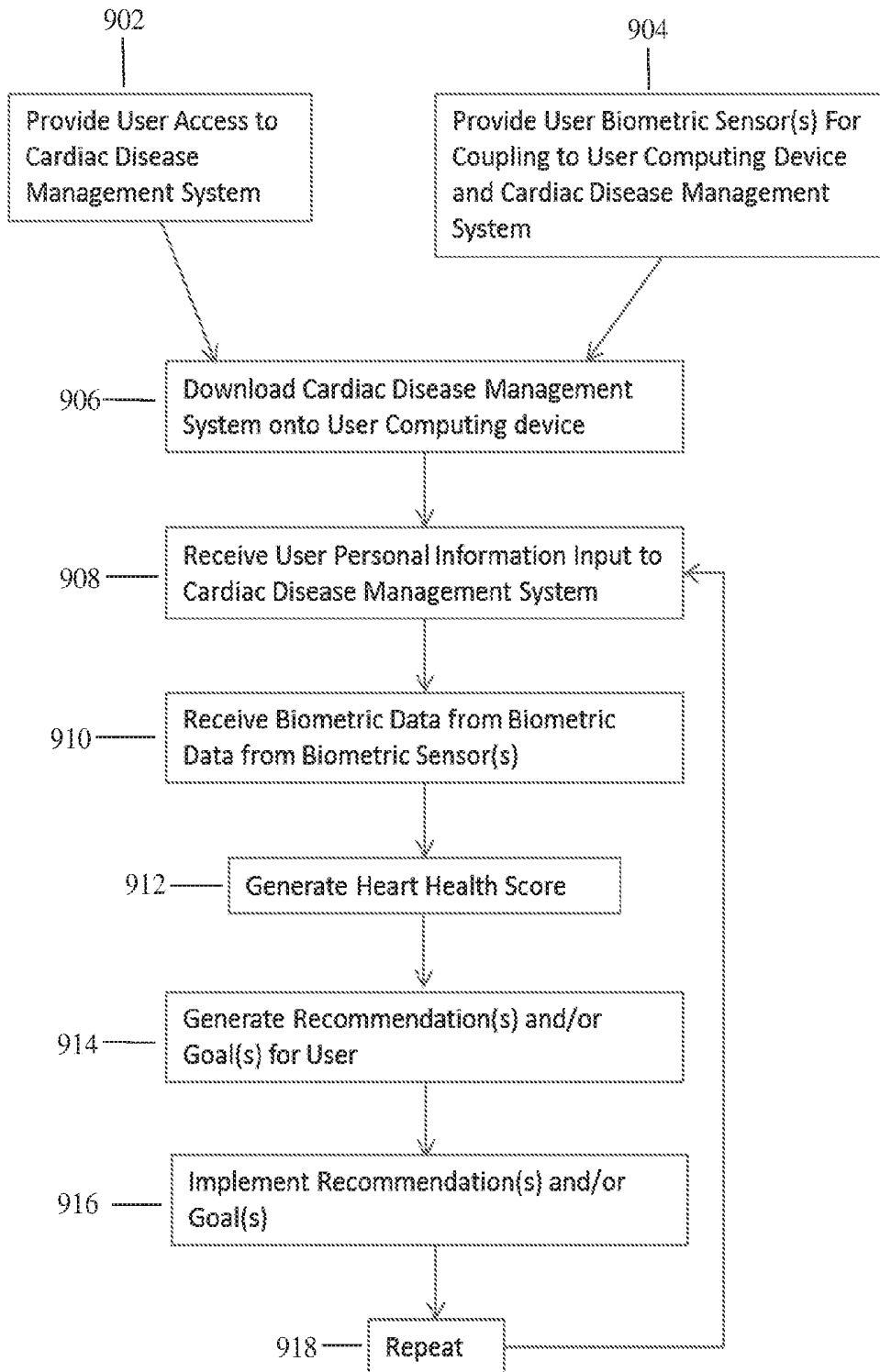

FIG. 9

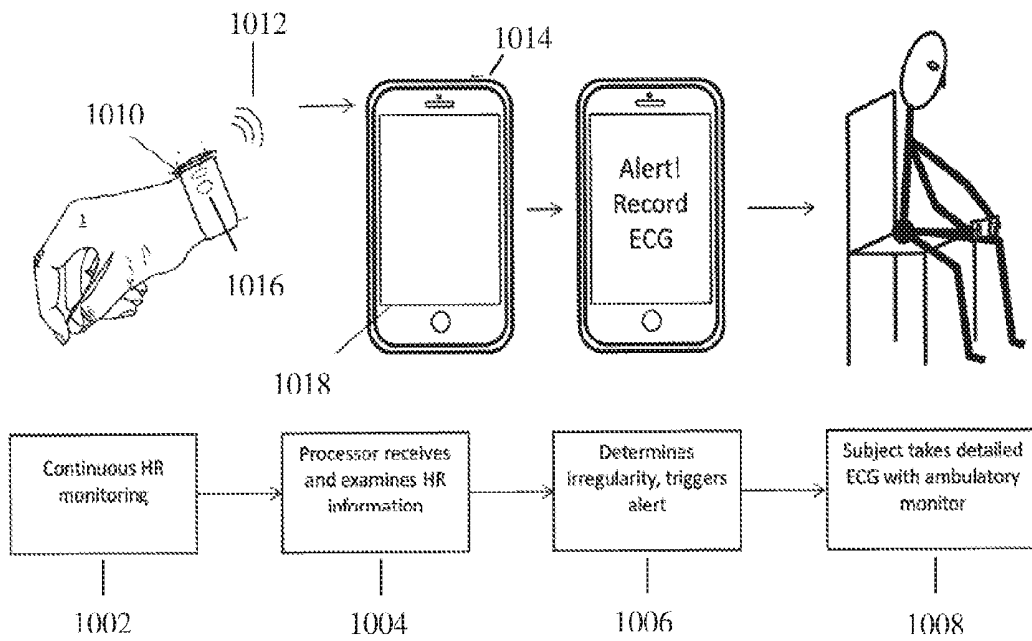

FIG. 10

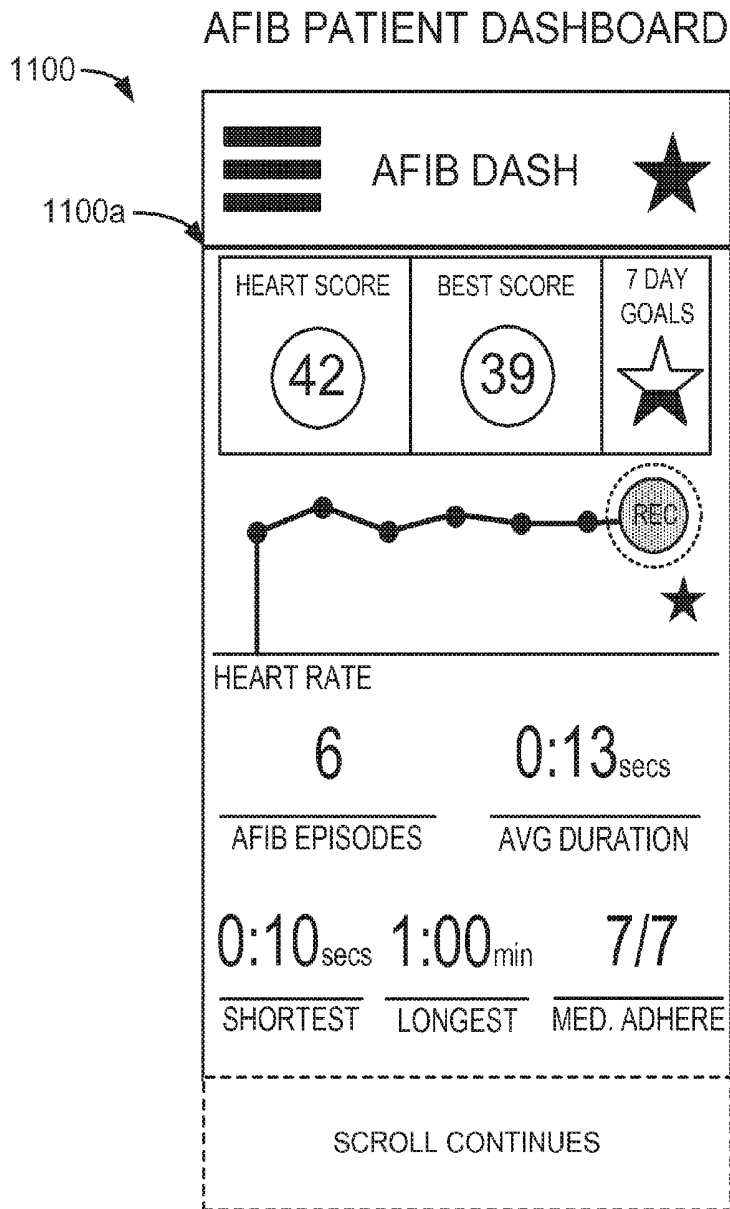

FIG. 11

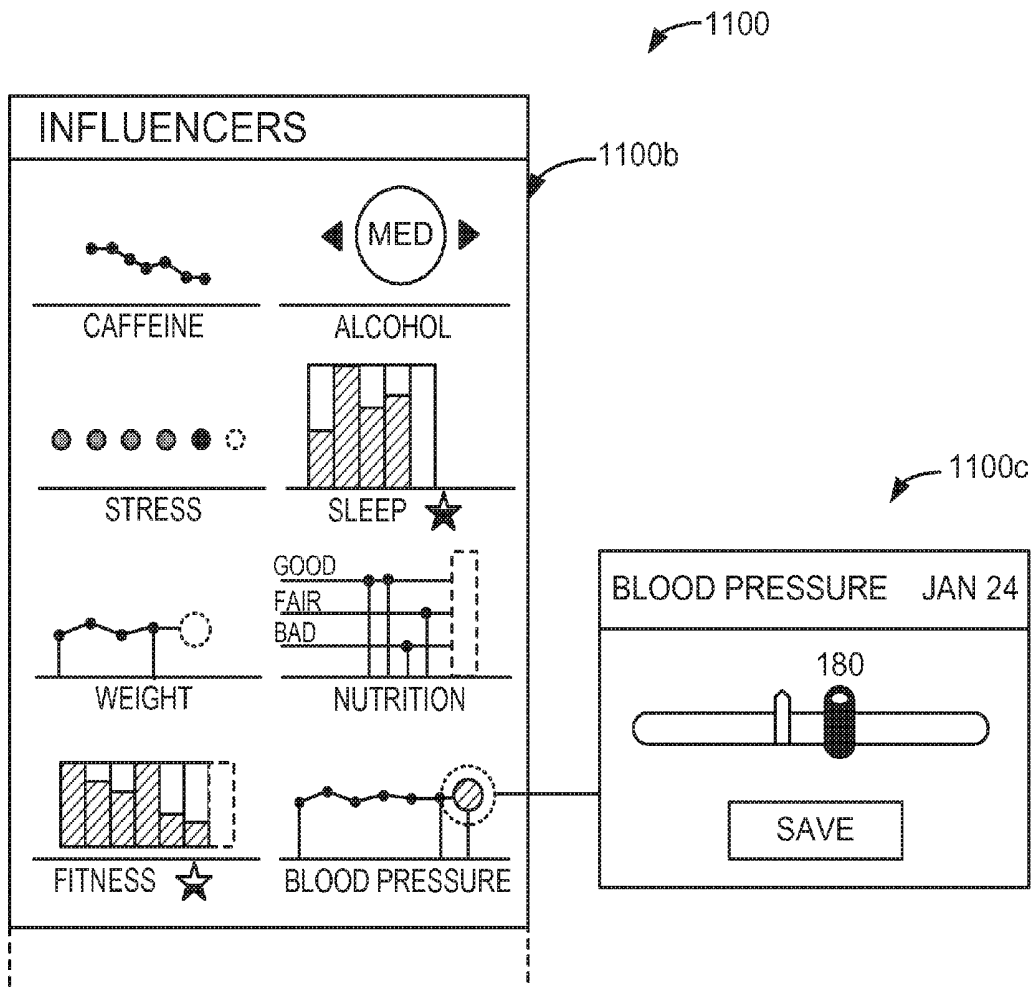

FIG. 11A

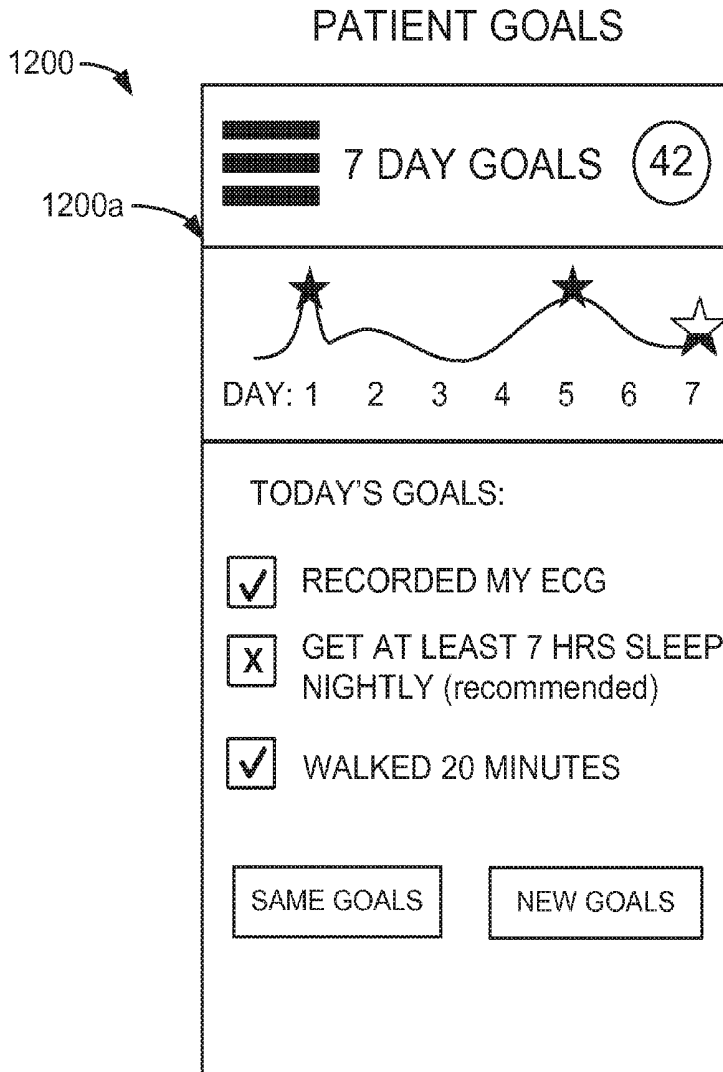

FIG. 12

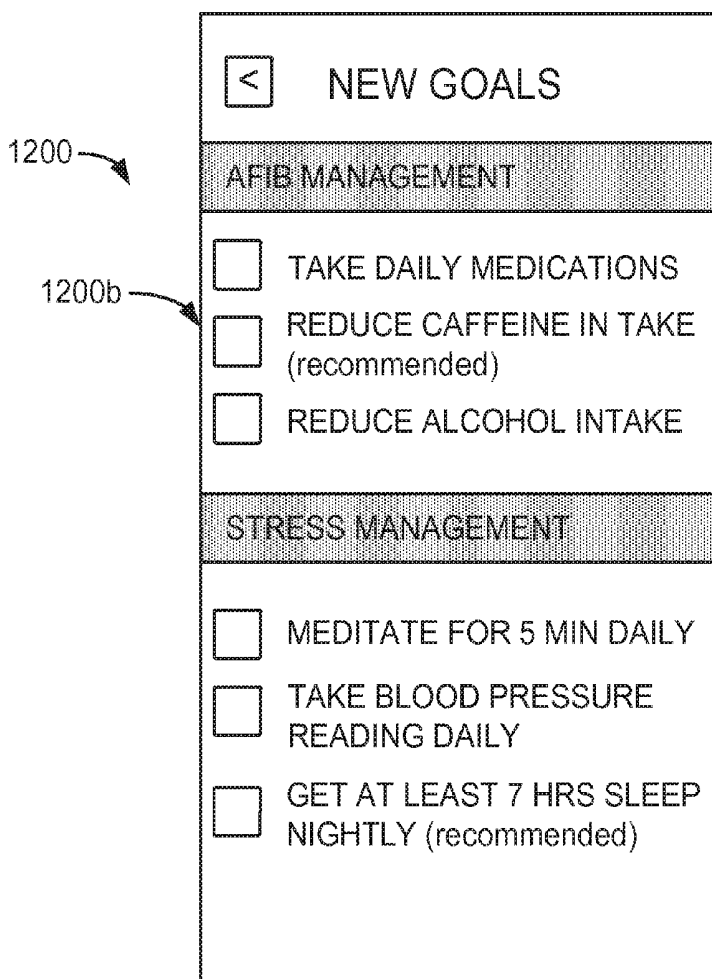

FIG. 12A

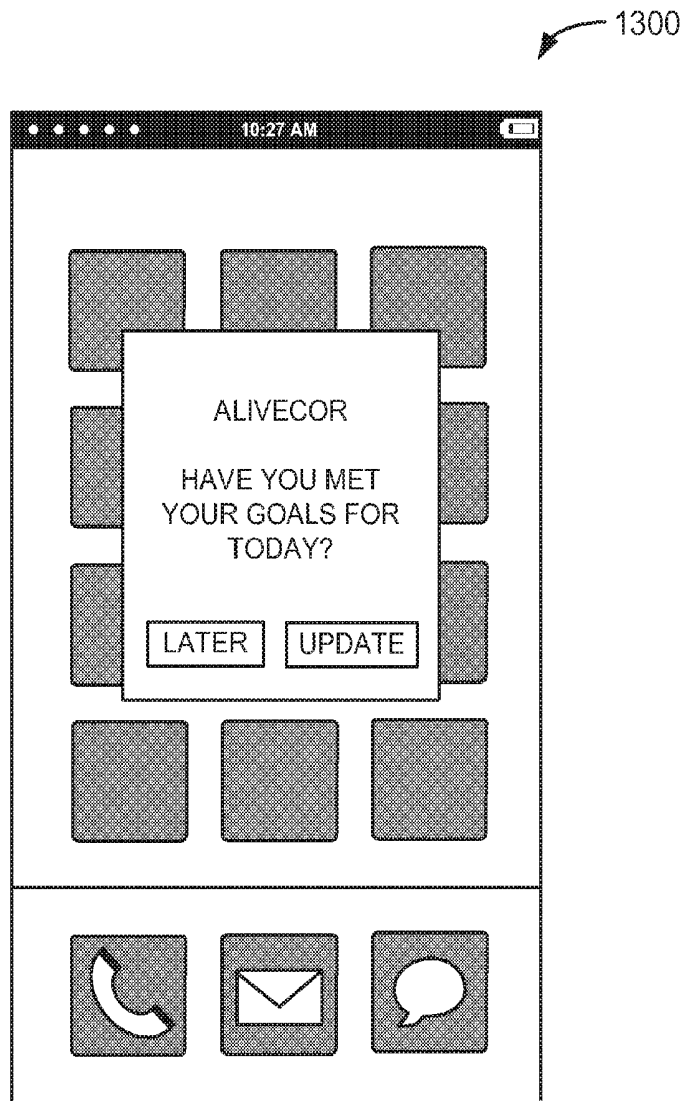

FIG. 13

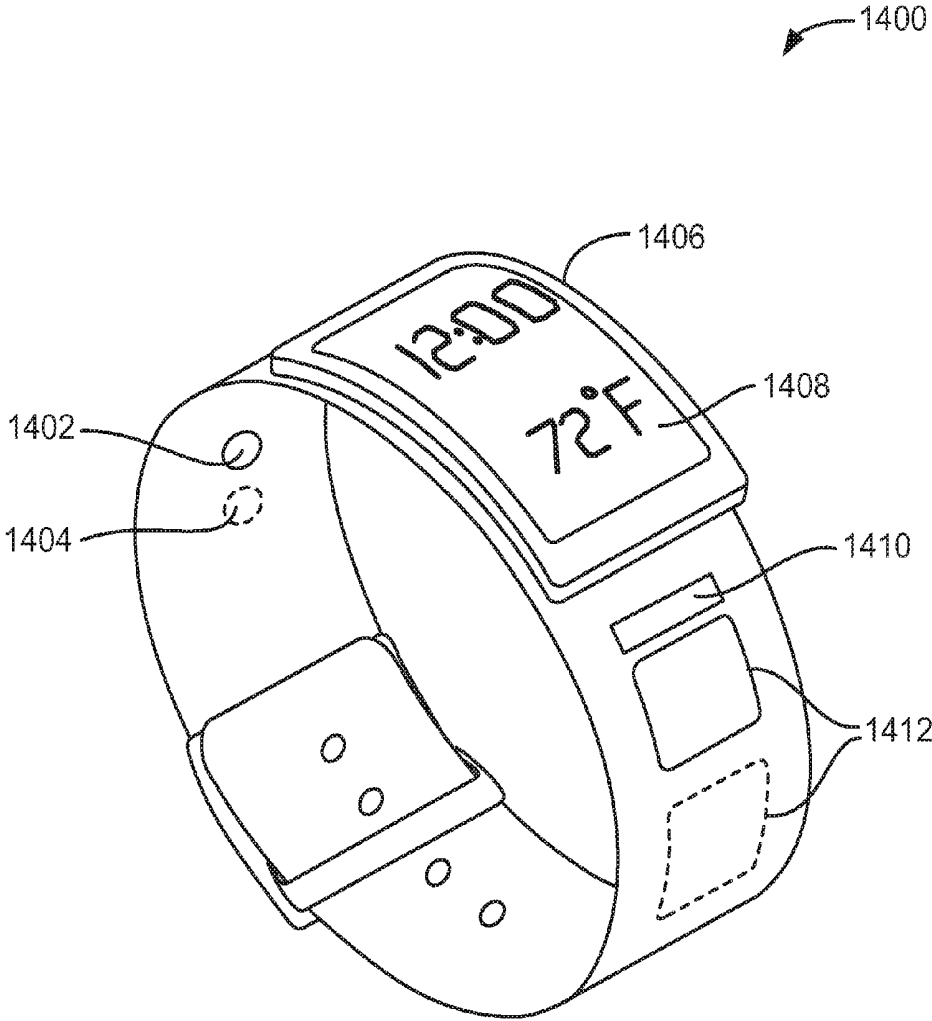

FIG. 14

METHODS AND SYSTEMS FOR ARRHYTHMIA TRACKING AND SCORING

CROSS-REFERENCE

This application claims the benefit of U.S. Provisional Application No. 61/915,113, filed Dec. 12, 2013, which application is incorporated herein by reference, U.S. Provisional Application No. 61/953,616 filed Mar. 14, 2014, U.S. Provisional Application No. 61/969,019, filed Mar. 21, 2014, U.S. Provisional Application No. 61/970,551 filed Mar. 26, 2014 which application is incorporated herein by reference, and U.S. Provisional Application No. 62/014,516, filed Jun. 19, 2014, which application is incorporated herein by reference.

BACKGROUND

The present disclosure relates to medical devices, systems, and methods. In particular, the present disclosure relates to methods and systems for managing health and disease such as cardiac diseases including arrhythmia and atrial fibrillation.

Cardiovascular diseases are the leading cause of death in the world. In 2008, 30% of all global death can be attributed to cardiovascular diseases. It is also estimated that by 2030, over 23 million people will die from cardiovascular diseases annually. Cardiovascular diseases are prevalent in the populations of high-income and low-income countries alike.

Arrhythmia is a cardiac condition in which the electrical activity of the heart is irregular or is faster (tachycardia) or slower (bradycardia) than normal. Although many arrhythmias are not life-threatening, some can cause cardiac arrest and even sudden cardiac death. Atrial fibrillation is the most common cardiac arrhythmia. In atrial fibrillation, electrical conduction through the ventricles of heart is irregular and disorganized. While atrial fibrillation may cause no symptoms, it is often associated with palpitations, shortness of breath, fainting, chest pain or congestive heart failure. Atrial fibrillation is also associated with atrial clot formation, which is associated with clot migration and stroke.

Atrial fibrillation is typically diagnosed by taking an electrocardiogram (ECG) of a subject, which shows a characteristic atrial fibrillation waveform

To treat atrial fibrillation, a patient may take medications to slow heart rate or modify the rhythm of the heart. Patients may also take anticoagulants to prevent atrial clot formation and stroke. Patients may even undergo surgical intervention including cardiac ablation to treat atrial fibrillation.

Often, a patient with arrhythmia or atrial fibrillation is monitored for extended periods of time to manage the disease. For example, a patient may be provided with a Holter monitor or other ambulatory electrocardiography device to continuously monitor a patient's heart rate and rhythm for at least 24 hours.

Current ambulatory electrocardiography devices such as Holter monitors, however, are typically bulky and difficult for subjects to administer without the aid of a medical professional. For example, the use of Holter monitors requires a patient to wear a bulky device on their chest and precisely place a plurality of electrode leads on precise locations on their chest. These requirements can impede the activities of the subject, including their natural movement, bathing, and showering. Once an ECG is generated, the ECG is sent to the patient's physician who may analyze the ECG and provide a diagnosis and other recommendations. Currently, this process often must be performed through hospital administrators and

health management organizations and many patients do not receive feedback in an expedient manner.

SUMMARY

Disclosed herein are devices, systems, and methods for managing health and disease such as cardiac diseases, including arrhythmia and atrial fibrillation. In particular, a cardiac disease and/or rhythm management system, according to aspects of the present disclosure, allows a user to conveniently document their electrocardiograms (ECG) and other biometric data and receive recommendation(s) and/or goal(s) generated by the system or by a physician in response to the documented data. The cardiac disease and/or rhythm management system can be loaded onto a local computing device of the user, where biometric data can be conveniently entered onto the system while the user may continue to use the local computing device for other purposes. A local computing device may comprise, for example, a computing device worn on the body (e.g. a head-worn computing device such as a Google Glass, a wrist-worn computing device such as a Samsung Galaxy Gear Smart Watch, etc.), a tablet computer (e.g. an Apple iPad, an Apple iPod, a Google Nexus tablet, a Samsung Galaxy Tab, a Microsoft Surface, etc.), a smartphone (e.g. an Apple iPhone, a Google Nexus phone, a Samsung Galaxy phone, etc.)

A portable computing device or an accessory thereof may be configured to continuously measure one or more physiological signals of a user. The heart rate of the user may be continuously measured. The continuous measurement may be made with a wrist or arm band or a patch in communication with the portable computing device. The portable computing device may have loaded onto (e.g. onto a non-transitory computer readable medium of the computing device) and executing thereon (e.g. by a processor of the computing device) an application for one or more of receiving the continuously measured physiological signal(s), analyzing the physiological signal(s), sending the physiological signal(s) to a remote computer for further analysis and storage, and displaying to the user analysis of the physiological signal(s). The heart rate may be measured by one or more electrodes provided on the computing device or accessory, a motion sensor provided on the computing device or accessory, or by imaging and lighting sources provided on the computing device or accessory. In response to the continuous measurement and recordation of the heart rate of the user, parameters such as heart rate (HR), heart rate variability (R-R variability or HRV), and heart rate turbulence (HRT) may be determined. These parameters and further parameters may be analyzed to detect and/or predict one or more of atrial fibrillation, tachycardia, bradycardia, bigeminy, trigeminy, or other cardiac conditions. A quantitative heart health score may also be generated from the determined parameters. One or more of the heart health score, detected heart conditions, or recommended user action items based on the heart health score may be displayed to the user through a display of the portable computing device.

The biometric data may be uploaded onto a remote server where one or more cardiac technicians or cardiac specialists may analyze the biometric data and provide ECG interpretations, diagnoses, recommendations such as lifestyle recommendations, and/or goals such as lifestyle goals for subject. These interpretations, diagnoses, recommendations, and/or goals may be provided to the subject through the cardiac disease and/or rhythm management system on their local computing device. The cardiac disease and/or rhythm management system may also include tools for the subject to track

their biometric data and the associated interpretations, diagnoses, recommendations, and/or goals from the cardiac technicians or specialists.

An aspect of the present disclosure includes a dashboard centered around arrhythmia or atrial fibrillation tracking. The dashboard includes a heart score that can be calculated in response to data from the user such as their ECG and other personal information such as age, gender, height, weight, body fat, disease risks, etc. The main driver of this heart score will often be the incidence of the user's atrial fibrillation. Other drivers and influencing factors include the aforementioned personal information. The heart score will be frequently related to output from a machine learning algorithm that combines and weights many if not all of influencing factors.

The dashboard will often display and track many if not all of the influencing factors. Some of these influencing factors may be entered directly by the user or may be input by the use of other mobile health monitoring or sensor devices. The user may also use the dashboard as an atrial fibrillation or arrhythmia management tool to set goals to improve their heart score.

The dashboard may also be accessed by the user's physician (e.g. the physician prescribing the system to the user, another regular physician, or other physician) to allow the physician to view the ECG and biometric data of the user, view the influencing factors of the user, and/or provide additional ECG interpretations, diagnoses, recommendations, and/or goals.

Another aspect of the present disclosure provides a method for managing cardiac health. Biometric data of a user may be received. A cardiac health score may be generated in response to the received biometric data. One or more recommendations or goals for improving the generated cardiac health score may be displayed to the user. The biometric data may comprise one or more of an electrocardiogram (ECG), dietary information, stress level, activity level, gender, height, weight, age, body fat percentage, blood pressure, results from imaging scans, blood chemistry values, or genotype data. The recommendations or goals may be updated in response to the user meeting the displayed recommendations or goals. The user may be alerted if one or more recommendations or goals have not been completed by the user, for example if the user has not completed one or more recommendations or goals for the day.

The analysis applied may be through one or more of the generation of a heart health score or the application of one or more machine learning algorithms. The machine learning algorithms may be trained using population data of heart rate. The population data may be collected from a plurality of the heart rate monitoring enabled portable computing devices or accessories provided to a plurality of users. The training population of users may have been previously identified as either having atrial fibrillation or not having atrial fibrillation prior to the generation of data for continuously measured heart rate. The data may be used to train the machine learning algorithm to extract one or more features from any continuously measured heart rate data and identify atrial fibrillation or other conditions therefrom. After the machine learning algorithm has been trained, the machine learning algorithm may recognize atrial fibrillation from the continuously measured heart rate data of a new user who has not yet been identified as having atrial fibrillation or other heart conditions. One or more of training population data or the trained machine learning algorithm may be provided on a central computing device (e.g. be stored on a non-transitory computer readable medium of a server) which is in communica-

tion with the local computing devices of the users and the application executed thereon (e.g. through an Internet or an intranet connection.)

A set of instructions for managing cardiac health may be downloaded from the Internet. These set of instructions may be configured to automatically generate the cardiac health score. The cardiac health score may be generated using a machine learning algorithm. The machine learning algorithm may generate the cardiac health score of the user and/or the recommendations and/or goals in response to biometric data from a plurality of users. The set of instructions may be configured to allow a medical professional to access the received biometric data. The cardiac health score and/or the recommendations and/or goals may be generated by the medical professional.

The set of instructions may be stored on a non-transitory computer readable storage medium of one or more of a body-worn computer, a tablet computer, a smartphone, or other computing device. These set of instructions may be capable of being executed by the computing device. When executed, the set of instructions may cause the computing device to perform any of the methods described herein, including the method for managing cardiac health described above.

Another aspect of the present disclosure provides a system for managing cardiac health. The system may comprise a sensor for recording biometric data of a user and a local computing device receiving the biometric data from the sensor. The local computing device may be configured to display a cardiac health score and one or more recommendations or goals for the user to improve the cardiac health score in response to the received biometric data.

The system may further comprise a remote server receiving the biometric data from the local computing device. One or more of the local computing device or the remote server may comprise a machine learning algorithm which generates one or more of the cardiac health score or the one or more recommendations or goals for the user. The remote server may be configured for access by a medical professional. Alternatively or in combination, one or more of the cardiac health score or one or more recommendations or goals may be generated by the medical professional and provided to the local computing device through the remote server.

The sensor may comprise one or more of a hand-held electrocardiogram (ECG) sensor, a wrist-worn activity sensor, a blood pressure monitor, a personal weighing scale, a body fat percentage sensor, a personal thermometer, a pulse oximeter sensor, or any mobile health monitor or sensor. Often, the sensor is configured to be in wireless communication with the local computing device. The local computing device comprises one or more of a personal computer, a laptop computer, a palmtop computer, a tablet computer, a smartphone, a body-worn computer, or the like. The biometric data may comprise one or more of an electrocardiogram (ECG), dietary information, stress level, activity level, gender, height, weight, age, body fat percentage, or blood pressure.

Other physiological signals or parameters such as physical activity, heart sounds, blood pressure, blood oxygenation, blood glucose, temperature, activity, breath composition, weight, hydration levels, an electroencephalograph (EEG), an electromyography (EMG), a mechanomyogram (MMG), an electrooculogram (EOG), etc. may also be monitored. The user may also input user-related health data such as age, height, weight, body mass index (BMI), diet, sleep levels, rest levels, or stress levels. One or more of these physiological signals and/or parameters may be combined with the heart rate data to detect atrial fibrillation or other conditions. The

machine learning algorithm may be configured to identify atrial fibrillation or other conditions in response to heart rate data in combination with one or more of the other physiological signals and/or parameters for instance. Triggers or alerts may be provided to the user in response to the measured physiological signals and/or parameters. Such triggers or alerts may notify the user to take corrective steps to improve their health or monitor other vital signs or physiological parameters. The application loaded onto and executed on the portable computing device may provide a health dash board integrating and displaying heart rate information, heart health parameters determined in response to the heart rate information, other physiological parameters and trends thereof, and recommended user action items or steps to improve health.

INCORPORATION BY REFERENCE

All publications, patents, and patent applications mentioned in this specification are herein incorporated by reference to the same extent as if each individual publication, patent, or patent application was specifically and individually indicated to be incorporated by reference.

BRIEF DESCRIPTION OF THE DRAWINGS

The novel features of the subject matter disclosed herein are set forth with particularity in the appended claims. A better understanding of the features and advantages of the present disclosure will be obtained by reference to the following detailed description that sets forth illustrative embodiments, in which the principles of the disclosure are utilized, and the accompanying drawings of which:

FIG. 1 shows a system for cardiac disease and rhythm management;

FIG. 2 shows a flow chart of a method **200** for predicting and/or detecting atrial fibrillation from R-R interval measurements;

FIG. 3 shows a flow chart of a method for predicting and/or detecting atrial fibrillation from R-R interval measurements and for predicting and/or detecting atrial fibrillation from raw heart rate signals;

FIG. 4 shows an embodiment of the system and method of the ECG monitoring described herein;

FIG. 5 shows a flow chart of an exemplary method to generate a heart health score in accordance with many embodiments;

FIG. 6 shows an exemplary method of generating a heart score;

FIG. 7 shows a schematic diagram of the executed application described herein;

FIG. 8 shows exemplary screenshots of the executed application;

FIG. 9 shows an exemplary method for cardiac disease and rhythm management;

FIG. 10 shows an exemplary method for monitoring a subject to determine when to record an electrocardiogram (ECG);

FIG. 11 shows an exemplary screenshot of a first aspect of a dashboard application;

FIG. 11A shows an exemplary screenshot of a second aspect of a dashboard application;

FIG. 12 shows an exemplary screenshot of a first aspect of a goals and recommendations page of the cardiac disease and rhythm management system interface or mobile app;

FIG. 12A shows an exemplary screenshot of a second aspect of a goals and recommendations page of the cardiac disease and rhythm management system interface or mobile app;

FIG. 13 shows an exemplary screenshot of a user's local computing device notifying the user with a pop-up notice to meet their daily recommendations and goals; and

FIG. 14 shows an embodiment comprising a smart watch which includes at least one heart rate monitor and at least one activity monitor.

DETAILED DESCRIPTION

Devices, systems, and methods for managing health and disease such as cardiac diseases, including arrhythmia and atrial fibrillation, are disclosed. In particular, a cardiac disease and/or rhythm management system, according to aspects of the present disclosure, allows a user to conveniently document their electrocardiograms (ECG) and other biometric data and receive recommendation(s) and/or goal(s) generated by the system or by a physician in response to the documented data.

The term "atrial fibrillation," denoting a type of cardiac arrhythmia, may also be abbreviated in either the figures or description herein as "AFIB."

FIG. 1 shows a system **100** for cardiac disease and rhythm management. The system **100** may be prescribed for use by a user or subject such as being prescribed by the user or subject's regular or other physician or doctor. The system **100** may comprise a local computing device **101** of the user or subject. The local computing device **101** may be loaded with a user interface, dashboard, or other sub-system of the cardiac disease and rhythm management system **100**. For example, the local computing device **101** may be loaded with a mobile software application ("mobile app") **101a** for interfacing with the system **100**. The local computing device may comprise a computing device worn on the body (e.g. a head-worn computing device such as a Google Glass, a wrist-worn computing device such as a Samsung Galaxy Gear Smart Watch, etc.), a tablet computer (e.g. an Apple iPad, an Apple iPod, a Google Nexus tablet, a Samsung Galaxy Tab, a Microsoft Surface, etc.), a smartphone (e.g. an Apple iPhone, a Google Nexus phone, a Samsung Galaxy phone, etc.).

The local computing device **101** may be coupled to one or more biometric sensors. For example, the local computing device **101** may be coupled to a handheld ECG monitor **103**. The handheld ECG monitor **103** may be in the form of a smartphone case as described in co-owned U.S. patent application Ser. No. 12/796,188 (now U.S. Pat. No. 8,509,882), Ser. Nos. 13/107,738, 13/420,520 (now U.S. Pat. No. 8,301,232), Ser. Nos. 13/752,048, 13/964,490, 13/969,446, 14/015,303, and 14/076,076, the contents of which are incorporated herein by reference.

In some embodiments, the handheld ECG monitor **103** may be a handheld sensor coupled to the local computing device **101** with an intermediate protective case/adaptor as described in U.S. Provisional Application No. 61/874,806, filed Sep. 6, 2013, the contents of which are incorporated herein by reference. The handheld ECG monitor **103** may be used by the user to take an ECG measurement which the handheld ECG monitor **103** may send to the local computing device by connection **103a**. The connection **103a** may comprise a wired or wireless connection (e.g. a WiFi connection, a Bluetooth connection, a NFC connection, an ultrasound signal transmission connection, etc.). The mobile software application **101a** may be configured to interface with the one or more biometric sensors including the handheld ECG monitor **103**.

The local computing device **101** may be coupled to a wrist-worn biometric sensor **105** through a wired or wireless connection **105a** (e.g. a WiFi connection, a Bluetooth connec-

tion, a NFC connection, an ultrasound signal transmission connection, etc.). The wrist-worn biometric sensor **105** may comprise an activity monitor such as those available from Fitbit Inc. of San Francisco, Calif. or a Nike FuelBand available from Nike, Inc. of Oregon. The wrist-worn biometric sensor **105** may also comprise an ECG sensor such as that described in co-owned U.S. Provisional Application No. 61/872,555, the contents of which is incorporated herein by reference.

The local computing device **101** may be coupled to other biometric devices as well such as a personal scale or a blood pressure monitor **107**. The blood pressure monitor **107** may communicate with the local device **101** through a wired or wireless connection **107a** (e.g. a WiFi connection, a Bluetooth connection, a NFC connection, an ultrasound signal transmission connection, etc.).

The local computing device **101** may directly communicate with a remote server or cloud-based service **113** through the Internet **111** via a wired or wireless connection **111a** (e.g. a WiFi connection, a cellular network connection, a DSL Internet connection, a cable Internet connection, a fiber optic Internet connection, a T1 Internet connection, a T3 Internet connection, etc.). Alternatively or in combination, the local computing device **101** may first couple with another local computing device **109** of the user, such as a personal computer of the user, which then communicates with the remote server or cloud-based service **113** via a wired or wireless connection **109a** (e.g. a WiFi connection, a cellular network connection, a DSL Internet connection, a cable Internet connection, a fiber optic Internet connection, a T1 Internet connection, a T3 Internet connection, etc.) The local computing device **109** may comprise software or other interface for managing biometric data collected by the local computing device **101** or the biometric data dashboard loaded on the local computing device **101**.

Other users may access the patient data through the remote server or cloud-based service **113**. These other users may include the user's regular physician, the user's prescribing physician who prescribed the system **100** for use by the user, other cardiac technicians, other cardiac specialists, and system administrators and managers. For example, a first non-subject user may access the remote server or cloud-based service **113** with a personal computer or other computing device **115** through an Internet connection **115a** (e.g. a WiFi connection, a cellular network connection, a DSL Internet connection, a cable Internet connection, a fiber optic Internet connection, a T1 Internet connection, a T3 Internet connection, etc.). Alternatively or in combination, the first non-subject user may access the remote server or cloud-based service **113** with a local computing device such as a tablet computer or smartphone **117** through an Internet connection **117a**. The tablet computer or smartphone **117** of the first non-subject user may interface with the personal computer **115** through a wired or wireless connection **117b** (e.g. a WiFi connection, a Bluetooth connection, a NFC connection, an ultrasound signal transmission connection, etc.). Further, a second non-subject user may access the remote server or cloud-based service **113** with a personal computer or other computing device **119** through an Internet connection **119a** (e.g. a WiFi connection, a cellular network connection, a DSL Internet connection, a cable Internet connection, a fiber optic Internet connection, a T1 Internet connection, a T3 Internet connection, etc.). Further, a third non-subject user may access the remote server or cloud-based service **113** with a tablet computer or smartphone **121** through an Internet connection **121a** (e.g. a WiFi connection, a cellular network connection, a DSL Internet connection, a cable Internet connection, a

fiber optic Internet connection, a T1 Internet connection, a T3 Internet connection, etc.). Further, a fourth non-subject user may access the remote server or cloud-based service **113** with a personal computer or other computing device **123** through an Internet connection **123a** (e.g. a WiFi connection, a cellular network connection, a DSL Internet connection, a cable Internet connection, a fiber optic Internet connection, a T1 Internet connection, a T3 Internet connection, etc.). The first non-subject user may comprise an administrator or manager of the system **100**. The second non-subject user may comprise a cardiac technician. The third non-subject user may comprise a regular or prescribing physician of the user or subject. And, the fourth non-subject user may comprise a cardiac specialist who is not the user or subject's regular or prescribing physician. Generally, many if not all of the communication between various devices, computers, servers, and cloud-based services will be secure and HIPAA-compliant.

Aspects of the present disclosure provide systems and methods for detecting and/or predicting atrial fibrillation or other arrhythmias of a user by applying one or more machine learning-based algorithms. A portable computing device (or an accessory usable with the portable computing device) may provide R-R intervals and/or raw heart rate signals as input to an application loaded and executed on the portable computing device. The raw heart rate signals may be provided using an electrocardiogram (ECG) in communication with the portable computing device or accessory such as described in U.S. Ser. No. 13/964,490 filed Aug. 12, 2013, Ser. No. 13/420,520 filed Mar. 14, 2013, Ser. No. 13/108,738 filed May 16, 2011, and Ser. No. 12/796,188 filed Jun. 8, 2010. Alternatively or in combination, the raw heart rate signals may be provided using an on-board heart rate sensor of the portable computing device or by using photoplethysmography implemented by an imaging source and a light source of the portable computing device. Alternatively or in combination, the raw heart rate signals may be from an accessory device worn by the user or attached to the user (e.g. a patch) and which is in communication with the portable computing device. Such wearable accessory devices may include Garmin's Vivofit Fitness Band, Fitbit, Polar Heart Rate Monitors, New Balance's Balance Watch, Basis B1 Band, MIO Alpha, Withings Pulse, LifeCORE Heart Rate Monitor strap, and the like.

R-R intervals may be extracted from the raw heart rate signals. The R-R intervals may be used to calculate heart rate variability (HRV) which may be analyzed in many ways such as using time-domain methods, geometric methods, frequency-domain methods, non-linear methods, long term correlations, or the like as known in the art. Alternatively or in combination, the R-R intervals may be used for non-traditional measurements such as (i) determining the interval between every other or every three R-waves to evaluate for bigeminy or trigeminy or (ii) the generation of a periodic autoregressive moving average (PARMA).

The machine learning based algorithm(s) may allow software application(s) to identify patterns and/or features of the R-R interval data and/or the raw heart rate signals or data to predict and/or detect atrial fibrillation or other arrhythmias. These extracted and labelled features may be features of HRV as analyzed in the time domain such as SDNN (the standard deviation of NN intervals calculated over a 24 hour period), SDANN (the standard deviation of the average NN intervals calculated over short periods), RMSSD (the square root of the mean of the sum of the squares of the successive differences between adjacent NNs), SDDSD (the standard deviation of the successive differences between adjacent NNs), NN50 (the number of pairs of successive NNs that differ by more than 50 ms), pNN50 (the proportion of NN50 divided by total number

of NNs), NN20 (the number of pairs of successive NNs that differ by more than 20 ms), pNN20 (the proportion of NN20 divided by the total number of NNs), EBC (estimated breath cycle), NNx (the number of pairs of successive NNs that differ by more than x ms), pNNx (the proportion of NNx divided by the number of NNs), or other features known in the art. Alternatively or in combination, the extracted and labelled features may comprise a nonlinear transform of R-R ratio or R-R ratio statistics with an adaptive weighting factor. Alternatively or in combination, the extracted and labelled features may be features of HRV as analyzed geometrically such as the sample density distribution of NN interval durations, the sample density distribution of differences between adjacent NN intervals, a Lorenz plot of NN or RR intervals, degree of skew of the density distribution, kurtosis of the density distribution, or other features known in the art. Alternatively or in combination, the extracted and labelled features may be features of HRV in the frequency domain such as the power spectral density of different frequency bands including a high frequency band (HF, from 0.15 to 0.4 Hz), low frequency band (LF, from 0.04 to 0.15 Hz), and the very low frequency band (VLF, from 0.0033 to 0.04 Hz), or other frequency domain features as known in the art. Alternatively or in combination, the extracted and labelled features may be non-linear features such as the geometric shapes of a Poincaré plot, the correlation dimension, the nonlinear predictability, the pointwise correlation dimension, the approximate entropy, and other features as known in the art. Other features from the raw heart rate signals and data may also be analyzed. These features include for example a generated autoregressive (AR) model, a ratio of consecutive RR intervals, a normalized ratio of consecutive RR intervals, a standard deviation of every 2, 3, or 4 RR intervals, or a recurrence plot of the raw HR signals, among others.

The features of the analysis and/or measurement may be selected, extracted, and labelled to predict atrial fibrillation or other arrhythmias in real time, e.g. by performing one or more machine learning operation. Such operations can be selected from among an operation of ranking the feature(s), classifying the feature(s), labelling the feature(s), predicting the feature(s), and clustering the feature(s). Alternatively or in combination, the extracted features may be labelled and saved for offline training of a machine learning algorithm or set of machine learning operations. For example, the operations may be selected from any of those above. Any number of machine learning algorithms or methods may be trained to identify atrial fibrillation or other conditions such as arrhythmias. These may include the use of decision tree learning such as with a random forest, association rule learning, artificial neural network, inductive logic programming, support vector machines, clustering, Bayesian networks, reinforcement learning, representation learning, similarity and metric learning, sparse dictionary learning, or the like.

The systems and methods for detecting and/or predicting atrial fibrillation or other conditions such as arrhythmias described herein may be implemented as software provided as a set of instructions on a non-transitory computer readable medium. A processor of a computing device (e.g. a tablet computer, a smartphone, a smart watch, a smart band, a wearable computing device, or the like) may execute this set of instructions to receive the input data and detect and/or predict atrial fibrillation therefrom. The software may be downloaded from an online application distribution platform such as the Apple iTunes or App Store, Google Play, Amazon App Store, and the like. A display of the computing device may notify the user whether atrial fibrillation or other arrhythmias has been detected and/or if further measurements are required

(e.g. to perform a more accurate analysis). The software may be loaded on and executed by the portable computing device of the user such as with the processor of the computing device.

The machine learning-based algorithms or operations for predicting and/or detecting atrial fibrillation or other arrhythmias may be provided as a service from a remote server which may interact or communicate with a client program provided on the computing device of the user, e.g. as a mobile app. The interaction or communication may be through an Application Program Interface (API). The API may provide access to machine learning operations for ranking, clustering, classifying, and predicting from the R-R interval and/or raw heart rate data, for example.

The machine learning-based algorithms or operations, provided through a remote server and/or on a local application on a local computing device, may operate on, learn from, and make analytical predictions from R-R interval data or raw heart rate data, e.g. from a population of users. The R-R interval or raw heart rate data may be provided by the local computing device itself or an associated accessory, such as described in U.S. Ser. No. 13/964,490 filed Aug. 12, 2013, Ser. No. 13/420,520 filed Mar. 14, 2013, Ser. No. 13/108,738 filed May 16, 2011, and Ser. No. 12/796,188 filed Jun. 8, 2010. Thus, atrial fibrillation and other arrhythmias or other heart conditions can be in a convenient, user-accessible way.

FIG. 2 shows a flow chart of a method 200 for predicting and/or detecting atrial fibrillation from R-R interval measurements. In a step 202, an R-R interval of a user is obtained. In a step 204, the obtained R-R interval is analyzed using one or more traditional heart rate variability measurements such as, for example, time domain measures, frequency domain measures, and non-linear heart rate variability. In a step 206, the obtained R-R interval is analyzed using one or more non-traditional heart rate variability measurements such as, for example, RR (n-i) for Bigeminy and Trigeminy detection, and the generation of a periodic autoregressive moving average (PARMA). In a step 208, a feature selection occurs. In a step 210, a real time prediction or detection of atrial fibrillation, and/or in a step 212, the heart rate variability measurements may be labelled and saved for offline training of a machine learning algorithm or set of machine learning operations, and then may be subsequently used to make a real time prediction and/or detection of atrial fibrillation.

FIG. 3 shows a flow chart of a method 300 for predicting and/or detecting atrial fibrillation from R-R interval measurements and for predicting and/or detecting atrial fibrillation from raw heart rate signals. In a step 302, raw heart rate signals are obtained from, for example, an ECG of a user. In a step 304, R-R intervals are obtained from the obtained raw heart signals. In a step 306, the obtained R-R interval is analyzed using one or more traditional heart rate variability measurements such as, for example, time domain measures, frequency domain measures, and non-linear heart rate variability. In a step 308, the obtained R-R interval is analyzed using one or more non-traditional heart rate variability measurements such as, for example, RR (n-i) for bigeminy and trigeminy detection, and the generation of a periodic autoregressive moving average (PARMA). In a step 310, features from the obtained heart rate features are analyzed using one or more of wavelet features and shape based features from a Hilbert transform. In a step 312, a feature selection occurs. In a step 314, a real time prediction or detection of atrial fibrillation, and/or in a step 316, the heart rate variability measurements may be labelled and saved for offline training of a machine learning algorithm or set of machine learning opera-

tions, and then may be subsequently used to make a real time prediction and/or detection of atrial fibrillation.

Although the above steps show methods 200 and 300 in accordance with many embodiments, a person of ordinary skill in the art will recognize many variations based on the teaching described herein. The steps may be completed in a different order. Steps may be added or deleted. Some of the steps may comprise sub-steps. Many of the steps may be repeated as often as beneficial to the user or subject.

One or more of the steps of method 200 and 300 may be performed with circuitry, for example, one or more of a processor or a logic circuitry such as a programmable array logic for a field programmable gate array. The circuitry may be programmed to provide one or more of the steps of methods 200 and 300, and the program may comprise program instructions stored on a non-transitory computer readable medium or memory or programmed steps of the logic circuitry such as the programmable array logic or the field programmable gate array, for example.

Aspects of the present disclosure provide systems and methods for monitoring one or more physiological parameters and providing a trigger message to the user if the one or more physiological parameter meets a pre-determined or learned threshold(s). Two or more of the physiological parameters may be combined to provide a trigger message. That is, a particular trigger message may be provided to the user if two or more pre-determined threshold(s) for the physiological parameter(s) are met.

Table 1 below shows an exemplary table of physiological parameters that may be measured (left column), features of interest to be measured or threshold types to be met (middle column), and exemplary trigger messages (right column).

TABLE 1

Physiological Parameter	Measurements/Threshold	Sample Trigger Messages
Heart Rate	Heart Rate Variability (HRV), Non-linear Transformation of RR Intervals	Measure ECG; See Your Doctor
Heart Sound	Sound Features	Abnormal Heart Sound; Measure ECG; See Your Doctor
Blood Pressure	Upper and Lower Thresholds	High/Low Blood Pressure; Take BP Medication; Exercise; See Your Doctor
Blood Oxygenation	O2 Saturation, O2 Saturation Variability	High Risk of Hypoventilation; High Risk of Sleep Disorder such as Apnea; See Your Doctor
Blood Glucose	Upper and Lower Thresholds	High Risk of Hypoglycemia; See Your Doctor
Temperature	Temperature, Temperature Changes	Fever; Take OTC Fever Medication; See Your Doctor
Physical Activity (accelerometer data)	Gait, Chest Compressions, Speed, Distance	Monitor Senior or Infant Posture, e.g. if senior/infant has fallen
Electrocardiogram (ECG)	ECG Features (E.g. QT, QRS, PR intervals, HRV, etc.)	High Risk of Certain Cardiac Diseases; Sleep apnea; See Your Doctor
Breath Content (Breathalyzer data)	Percentage of the Certain Chemicals	High Risk of Certain Dental Disease, Diabetes, etc.; See Your Doctor

The machine learning based algorithms or operations as described herein may be used to determine the appropriate trigger thresholds in response to the raw physiological data input and/or user-input physiological parameters (e.g. age, height, weight, gender, etc.). Features of the raw physiological data input may be selected, extracted, labelled, clustered, and/or analyzed. These processed features may then be analyzed using one or more machine learning operation such as ranking the feature(s), classifying the feature(s), predicting

the feature(s), and clustering the feature(s). The various machine learning algorithms described herein may be used to analyze the features to detect and predict health conditions and generate recommendations or user action items to improve the health of the user. For instance, the machine learning algorithms may be trained to identify atrial fibrillation or other conditions in response to the non-heart rate physiological parameter(s) such as age, gender, body mass index (BMI), activity level, diet, and others in combination with the raw heart rate data and HRV that can be extracted therefrom.

The systems and methods for monitoring one or more physiological parameters and providing a trigger message to the user if the one or more physiological parameter meets a pre-determined threshold(s) described herein may be implemented as software provided as a set of instructions on a non-transitory computer readable medium. A processor of a computing device (e.g. a tablet computer, a smartphone, a smart watch, a smart band, a wearable computing device, or the like) may execute this set of instructions to receive the input data and detect and/or predict atrial fibrillation therefrom. The software may be downloaded from an online application distribution platform such as the Apple iTunes or App Store, Google Play, Amazon App Store, and the like. The software may be loaded on and executed by the portable computing device of the user such as with the processor of the computing device. The software may also provide both the triggering application described herein and the heart rate monitoring and analysis for detecting atrial fibrillation or other heart conditions described herein.

In an embodiment, a method and system for longitudinal monitoring of a patient's or any consumer's (after referred to

as "patient") health using various ECG monitoring devices is described herein. The ECG monitoring devices generate ECG signal data which can be stored in a database for further analysis. The ECG data, which can be stored in a database along with other patient information, can be analyzed by a processing device, such as a computer or server, using various algorithms.

Various ECG monitoring or recording devices, hereinafter referred to as ECG monitoring devices, can be used to record

the ECG data. For example, the ECG monitoring device can be a handheld, portable, or wearable smartphone based device, as described in U.S. Pat. No. 8,301,232, which is herein incorporated by reference in its entirety for all purposes. A smartphone based device, or a device having wireless or cellular telecommunication capabilities, can transmit the ECG data to a database or server directly through the internet. These types of ECG monitoring devices as well as other ECG monitoring devices include portable devices, wearable recording devices, event recorders, and Holter monitors. Clinical or hospital based ECG recording devices can also be used and integrated into the system. Such devices may be able to transmit stored ECG data through a phone line or wirelessly through the internet or cellular network, or may need to be sent to a data collection center for data collection and processing. The ECG data can be tagged with the type of ECG monitoring device used to record the data by, for example, including it in metadata for indexing and searching purposes.

The ECG monitoring devices can be single lead devices or multiple lead devices, where each lead generally terminates with an electrode. Some embodiments may even be leadless and have electrodes that are integrated with the body or housing of the device, and therefore have a predetermined relationship with each other, such as a fixed spacing apart from each other. The orientation and positioning of the single lead in a single lead device or of each lead of the multiple lead device or of the electrodes of the leadless device can be transmitted with the ECG data. The lead and/or electrode placement may be predetermined and specified to the patient in instructions for using the device. For example, the patient may be instructed to position the leads and/or electrodes with references to one or more anatomical landmarks on the patient's torso. Any deviation from the predetermined lead and/or electrode placement can be noted by the patient or user when transmitting the ECG data. The lead and electrode placement may be imaged using a digital camera, which may be integrated with a smart phone, and transmitted with the ECG data and stored in the database. The lead and electrode placement may be marked on the patient's skin for imaging and for assisting subsequent placement of the leads and electrodes. The electrodes can be attached to the skin using conventional methods which may include adhesives and conducting gels, or the electrodes may simply be pressed into contact with the patient's skin. The lead and electrode placement may be changed after taking one recording or after recording for a predetermined or variable amount of time. The ECG data can be tagged with the numbers of leads and/or electrodes and the lead and/or electrode placement, including whether adhesives and/or conducting gels were used. Again, this information can be included in metadata for indexing and searching purposes.

The ECG signal data can be continuously recorded over a predetermined or variable length of time. Continuous ECG recording devices can record for up to 1, 2, 3, 4, 5, 6, 7, 8, 9, 10, 11, 12, 13, or 14 days. Alternatively or additionally, the ECG data can be recorded on demand by the patient at various discrete times, such as when the patient feels chest pains or experiences other unusual or abnormal feelings. The on demand ECG recorder can have a memory buffer that can record a predetermined amount of ECG data on a rolling basis, and when activated by the patient to record a potential event, a predetermined amount of ECG data can be saved and/or transmitted. The predetermined amount of ECG data can include a predetermined amount of ECG data before activation and a predetermined amount of ECG data after activation such that a window of ECG data is captured that

encompasses the potential event. The time period between ECG recordings may be regular or irregular. For example, the time period may be once a day, once a week, once a month, or at some other predetermined interval. The ECG recordings may be taken at the same or different times of days, under similar or different circumstances, as described herein. One or more baseline ECGs can be recorded while the patient is free of symptoms. The baseline ECGs can be periodically recorded and predetermined intervals and/or on-demand. The same ECG recording device or different ECG recording devices may be used to record the various ECG of a particular patient. All this information may be tagged to or associated with the ECG data by, for example, including it in the metadata for indexing and searching purposes.

The ECG data can be time stamped and can be annotated by the patient or health care provider to describe the circumstances during which the ECG was recorded, preceding the ECG recording, and/or following the ECG recording. For example, the system and device can have a user interface for data entry that allows the patient to enter in notes regarding the conditions and circumstances surrounding the ECG recording. This additional data can be also included as metadata for indexing and searching purposes. For example, location, food, drink, medication and/or drug consumption, exercise, rest, sleep, feelings of stress, anxiety, pain or other unusual or abnormal feelings, or any other circumstance that may affect the patient's ECG signal can all be inputted into the device, smart phone, computer or other computing device to be transmitted to the server or database along with the ECG data. The annotated data can also include the patient's identity or unique identifier as well as various patient characteristics including age, sex, race, ethnicity, and relevant medical history. The annotated data can also be time stamped or tagged so that the ECG data can be matched or correlated with the activity or circumstance of interest. This also allows comparison of the ECG before, after and during the activity or circumstance so that the effect on the ECG can be determined.

The ECG data and the associated metadata can be transmitted from the device to a server and database for storage and analysis. The transmission can be real-time, at regular intervals such as hourly, daily, weekly and any interval in between, or can be on demand. The metadata facilitates the searching, organizing, analyzing and retrieving of ECG data. Comparison and analysis of a single patient's ECG data can be performed, and/or comparison of ECG data between patients can be performed. For example, the metadata can be used to identify and select a subset of ECG data where an activity or circumstance, such as the taking of medication, occurred within a predetermined amount of time to the ECG data. The components of the ECG signal data, such as the P wave, T wave, and QRS complex and the like, the amplitudes of the components, the ratios between the components, the width of the components, and the delay or time separation between the components, can be extracted, compared, analyzed, and stored as ECG features. For example, the P wave and heart rate can be extracted and analyzed to identify atrial fibrillation, where the absence of P waves and/or an irregular heart rate may indicate atrial fibrillation. The extracted ECG features can also be included in the metadata for indexing and searching.

The changes in the ECG signal over time in view of the activities and circumstances can be compared with changes over time and circumstances observed within a database of ECG's. Comparisons may include any comparison of data derived from any other ECG signal or any database of ECG's or any subset of ECG data, or with data derived from any database of ECG's. Changes in any feature of the ECG signal

over time may be used for a relative comparison with similar changes in any ECG database or with data derived from an ECG database. The ECG data from the baseline ECG and the ECG data from a potential adverse event can be compared to determine the changes or deviations from baseline values. In addition, both the baseline ECG and the ECG data recorded from the patient can be compared to one or more predetermined template ECGs which can represent a normal healthy condition as well as various diseased conditions, such as myocardial infarction and arrhythmias.

The comparisons and analysis described herein can be used to draw conclusions and insights into the patient's health status, which includes potential health issues that the patient may be experiencing at the time of measurement or at future times. Conclusions and determinations may be predictive of future health conditions or diagnostic of conditions that the patient already has. The conclusions and determinations may also include insights into the effectiveness or risks associated with drugs or medications that the patient may be taking, have taken or may be contemplating taking in the future. In addition, the comparisons and analysis can be used to determine behaviors and activities that may reduce or increase risk of an adverse event. Based on the comparisons and analysis described herein, the ECG data can be classified according to a level of risk of being an adverse event. For example, the ECG data can be classified as normal, low risk, moderate risk, high risk, and/or abnormal. The normal and abnormal designation may require health care professional evaluation, diagnosis, and/or confirmation.

Diagnosis and determination of an abnormality, an adverse event, or a disease state by physicians and other health care professionals can be transmitted to the servers and database to be tagged with and associated with the corresponding ECG data. The diagnosis and determination may be based on analysis of ECG data or may be determined using other tests or examination procedures. Professional diagnosis and determinations can be extracted from the patient's electronic health records, can be entered into the system by the patient, or can be entered into the system by the medical professional. The conclusions and determinations of the system can be compared with actual diagnosis and determinations from medical professions to validate and/or refine the machine learning algorithms used by the system. The time of occurrence and duration of the abnormality, adverse event or disease state can also be included in the database, such that the ECG data corresponding with the occurrence and/or the ECG data preceding and/or following the abnormality, adverse event or disease state can be associated together and analyzed. The length of time preceding or following the abnormality may be predetermined and be up to 1 to 30 days, or greater than 1 to 12 months. Analysis of the time before the abnormality, adverse event or disease state may allow the system to identify patterns or correlations of various ECG features that precede the occurrence of the abnormality, adverse event or disease state, thereby providing advance detection or warning of the abnormality, adverse event or disease state. Analysis of the time following the abnormality, adverse event or disease state can provide information regarding the efficacy of treatments and/or provide the patient or physician information regarding disease progression, such as whether the patient's condition is improving, worsening or staying the same. The diagnosis and determination can also be used for indexing by, for example, including it in the metadata associated with the corresponding ECG data.

As described herein, various parameters may be included in the database along with the ECG data. These may include the patient's age, gender, weight, blood pressure, medica-

tions, behaviors, habits, activities, food consumption, drink consumption, drugs, medical history and other factors that may influence a patient's ECG signal. The additional parameters may or may not be used in the comparison of the changes in ECG signal over time and circumstances.

The conclusions, determinations, and/or insights into the patient's health generated by the system may be communicated to the patient directly or via the patient's caregiver (doctor or other healthcare professional). For example, the patient can be sent an email or text message that is automatically generated by the system. The email or text message can be a notification which directs the patient to log onto a secure site to retrieve the full conclusion, determination or insight, or the email or text message can include the conclusion, determination or insight. Alternatively or additionally, the email or text message can be sent to the patient's caregiver. The notification may also be provided via an application on a smartphone, tablet, laptop, desktop or other computing device.

As described herein, the system can identify behaviors, habits, activities, foods, drinks, medications, drugs, and the like which are associated with the patient's abnormal ECG readings. In addition to informing the patient of these associations, the system can provide instructions or recommendations to the patient to avoid these behaviors, habits, activities, foods, drinks, medications, drugs, and the like which are associated with the patient's abnormal ECG readings. Similarly, the system can identify behaviors, habits, activities, foods, drinks, medications, drugs, and the like which are associated with normal or improving ECG readings, and can instruct or recommend that the patient perform these behaviors, habits, and activities and/or consume these foods, drinks, medications, and drugs. The patient may avoid a future healthcare issue, as instructed or recommended by the system, by modifying their behavior, habits or by taking any course of action, including but not limited to taking a medication, drug or adhering to a diet or exercise program, which may be a predetermined course of action recommended by the system independent of any analysis of the ECG data, and/or may also result from insights learned through this system and method as described herein. In addition, the insights of the system may relate to general fitness and or mental wellbeing.

The ECG data and the associated metadata and other related data as described herein can be stored in a central database, a cloud database, or a combination of the two. The data can be indexed, searched, and/or sorted according to any of the features, parameters, or criteria described herein. The system can analyze the ECG data of a single patient, and it can also analyze the ECG data of a group of patients, which can be selected according to any of the features, parameters or criteria described herein. When analyzing data from a single patient, it may be desirable to reduce and/or correct for the intra-individual variability of the ECG data, so that comparison of one set of ECG data taken at one particular time with another set of ECG data taken at another time reveals differences resulting from changes in health status and not from changes in the type of ECG recording device used, changes in lead and electrode placement, changes in the condition of the skin (i.e. dry, sweaty, conductive gel applied or not applied), and the like. As described above, consistent lead and electrode placement can help reduce variability in the ECG readings. The system can also retrieve the patient's ECG data that were taken under similar circumstances and can analyze this subset of ECG data.

FIG. 4 illustrates an embodiment of the system and method 400 of ECG monitoring described herein. The system can be implemented on a server or computer having a processor for

executing the instructions described herein, which can be stored in memory. In step 402, ECG data can be recorded using any of the devices described herein for one or more patients. In step 404, the ECG data is transmitted along with associated metadata to a server and database that stores the ECG data. In step 406, a subset of the ECG data can be selected based on criteria in the metadata, such as user identity, time, device used to record the ECG data, and the like. In step 408, the subset of ECG data can be analyzed using a machine learning algorithm, which can assign a risk level to the ECG data in step 410. The system can then determine whether the risk level is high, as shown in step 412. If the risk level is low, the user can be notified that the ECG is normal or low risk, as shown in step 414. If the risk level is high, a high risk level alert can be sent to the patient with the option of sending the ECG to the medical professional for interpretation, as shown in step 416. The system then waits for the user's response to determine whether the patient elects to send the ECG to the medical professional for interpretation, as shown in step 418. If the patient does not wish to send the ECG to the medical professional for interpretation, the system can end the routine at this point, as shown in 420. If the patient does elect to send the ECG to the medical professional for interpretation, the request can be transmitted to the medical professional in step 422. The request to the medical professional can be sent to a workflow auction system as described in U.S. Provisional Application No. 61/800,879, filed Mar. 15, 2013, which is herein incorporated by reference in its entirety for all purposes. Once the medical professional has interpreted the ECG, the system can receive and store the ECG interpretation from the medical professional in the database, as shown in step 424. The system can then notify the user of the professional ECG interpretation, which can be sent to or accessed by the user, as shown in step 426. Additionally, the system can compare the assigned risk level with the medical diagnosis in step 428 and can determine whether the risk level determined by the system agrees with the medical diagnosis in step 430. If the risk level does not agree with the medical diagnosis, the machine learning algorithm can be adjusted until the risk level matches the medical diagnosis, as shown in step 432. If the risk level does agree with the medical diagnosis, the routine can be ended as shown in step 434.

Although the above steps show a method 400 in accordance with many embodiments, a person of ordinary skill in the art will recognize many variations based on the teaching described herein. The steps may be completed in a different order. Steps may be added or deleted. Some of the steps may comprise sub-steps. Many of the steps may be repeated as often as beneficial to the user or subject.

One or more of the steps of a method 400 may be performed with circuitry, for example, one or more of a processor or a logic circuitry such as a programmable array logic for a field programmable gate array. The circuitry may be programmed to provide one or more of the steps of a method 400, and the program may comprise program instructions stored on a non-transitory computer readable medium or memory or programmed steps of the logic circuitry such as the programmable array logic or the field programmable gate array, for example.

Aspects of the present disclosure provide systems and methods for generating a heart health score in response to continuously measured or monitored physiological parameter(s). The score may be given a quantitative value such as be graded from A to F or 0 to 100 for example (e.g. a great score may be an A or 100, a good score may be a B or 75, a moderate score may be a C or 50, a poor score may be a D or 25, and a failing score may be an F or 0.) If an arrhythmia is detected,

the score may be below 50 for example. Other scoring ranges such as A to Z, 1 to 5, 1 to 10, 1 to 1000, etc. may also be used. Arrhythmia may be detecting using the machine learning based operations or algorithms described herein.

FIG. 5 shows a flow chart of an exemplary method 500 to generate a heart health score in accordance with many embodiments.

In a step 502, an arrhythmia is detected. If an arrhythmia is detected (e.g. using the methods and/or algorithms disclosed herein), then the heart health score generated will be below 50. Depending on the severity of the arrhythmia detected, the heart score may be calculated or assigned within the ranges according to the table below in Table 2.

TABLE 2

Arrhythmia	Heart Health score
ATRIAL FIBRILLATION, HR below 100	30-45
ATRIAL FIBRILLATION, HR above 100	15-30
Sinus Tachycardia	20-40
Supraventricular Tachycardia	20-40
Bradycardia	20-40
Bigeminy, Trigeminy	30-50
Short runs of High Heart Rate (VTACH suspect)	10-30

In a step 504 a Heart Rate Variability (HRV) is calculated. HRV can be an indicator of heart health. The value for HRV value for a healthy heart is typically higher than HRV for an unhealthy heart. Also, HRV typically declines with age and may be affected by other factors, like stress, lack of physical activity, etc. HRV may be measured and analyzed using the methods described above. HRV may be calculated in the absence of arrhythmia, which may improve the accuracy of the HRV measurement. HRV may be determined and further analyzed as described above.

In a step 506, premature beats are counted and Heart Rate Turbulence (HRT) is calculated. Premature beats in the sequence of R-R intervals may be detected. Also, R-R intervals typically tend to recover at a certain pace after a premature beat. Using these two parameters (prematurity and pace of R-R recovery), HRT parameters may be calculated. There may be known deviations of HRT parameters associated with patients with risk of Congestive Heart Failure (CHF). These deviations, however, may be used to estimate an inverse measure. The number of premature beats per day (or per hour) may also be used as a measure of heart health. A low number of premature beats may indicate better heart health. In summary, the heart health score may be generated by combining at least heart rate variability (HRV), the number of premature beats, and heart rate turbulence (HRT). This combination (in the absence of arrhythmia) may provide an accurate estimate of how healthy the heart of the user is.

In a step 508, a heart health score is generated, and in a step 510, a heart health score is generated based on an arrhythmia. To initially generate the score, a few hours (e.g. 2-5 hours) of measured R-R intervals may be required. A more accurate score may be generated after a week of continuous R-R interval measurements. Longer data sets may be required to detect significant arrhythmias as they may usually be detected within the first 7-8 days of monitoring.

Although the above steps show a method 500 in accordance with many embodiments, a person of ordinary skill in the art will recognize many variations based on the teaching described herein. The steps may be completed in a different order. Steps may be added or deleted. Some of the steps may comprise sub-steps. Many of the steps may be repeated as often as beneficial to the user or subject.

One or more of the steps of a method **500** may be performed with circuitry, for example, one or more of a processor or a logic circuitry such as a programmable array logic for a field programmable gate array. The circuitry may be programmed to provide one or more of the steps of a method **500**, and the program may comprise program instructions stored on a non-transitory computer readable medium or memory or programmed steps of the logic circuitry such as the programmable array logic or the field programmable gate array, for example.

FIG. **6** shows a further method **600** of generating a heart score. In addition to the parameters which may be derived from the heart rate data described above, the heart health score may also be generated in response to further physiological parameters as shown in FIG. **6**.

In a step **602**, a raw ECG waveform is obtained. In a step **608**, ECG parameters are extracted from the raw ECG waveform data and arrhythmia prediction and/or detection algorithms are run to analyze the obtained raw ECG waveform data.

In a step **604**, physiological parameters may be measured using a sensor of the user's local computing device or an accessory thereof. Such measured physiological parameters may include blood pressure, user activity and exercise level, blood oxygenation levels, blood sugar levels, an electrocardiogram, skin hydration or the like of the user. These physiological parameters may be measured over time such as over substantially the same time scale or length as the measurement of heart rate. In a step **610**, an R-R interval is extracted and both traditional and non-traditional heart rate measures are used to analyze the measured heart rate and physiological parameters.

In a step **606**, additional physiological parameters for determining the heart health score may be input by the user. These parameters may include the age, the gender, the weight, the height, the body type, the body mass index (BMI), the personal medical history, the family medical history, the exercise and activity level, the diet, the hydration level, the amount of sleep, the cholesterol level, the alcohol intake level, the caffeine intake level, the smoking status, and the like of the user. For example, the heart health score may be weighted by age and/or gender to provide the user an accurate assessment of his or her heart health in response to the heart rate data. In a step **612**, feature extraction is used to analyze the inputted physiological parameters.

In a step **614** feature ranking and/or feature selection occurs. In a step **618**, a real time prediction or detection of atrial fibrillation, and/or in a step **616**, the heart rate variability measurements may be labelled and saved for offline training of a machine learning algorithm or set of machine learning operations, and then may be subsequently used to make a real time prediction and/or detection of atrial fibrillation. A plurality of heart health scores may be generated by a plurality of users to generate a set of population data. This population data may be used to train the machine learning algorithms described herein such that the trained algorithm may be able to detect and predict atrial fibrillation or other health conditions from user data.

Although the above steps show a method **600** in accordance with many embodiments, a person of ordinary skill in the art will recognize many variations based on the teaching described herein. The steps may be completed in a different order. Steps may be added or deleted. Some of the steps may comprise sub-steps. Many of the steps may be repeated as often as beneficial to the user or subject.

One or more of the steps of a method **600** may be performed with circuitry, for example, one or more of a processor

or a logic circuitry such as a programmable array logic for a field programmable gate array. The circuitry may be programmed to provide one or more of the steps of a method **600**, and the program may comprise program instructions stored on a non-transitory computer readable medium or memory or programmed steps of the logic circuitry such as the programmable array logic or the field programmable gate array, for example.

The systems and methods for generating a heart health score in response to continuously measured or monitored physiological parameter(s) may comprise a processor of a computing device and software. A processor of a computing device (e.g. a tablet computer, a smartphone, a smart watch, a smart band, a wearable computing device, or the like) may execute this set of instructions to receive the input data and detect and/or predict atrial fibrillation therefrom. The software may be downloaded from an online application distribution platform such as the Apple iTunes or App Store, Google Play, Amazon App Store, and the like. A display of the computing device may notify the user of the calculated heart health score and/or if further measurements are required (e.g. to perform a more accurate analysis).

FIG. **7** shows a schematic diagram of the executed application described herein. The heart health score may be provided on a software application such as a mobile app downloaded from an application distribution platform and executed on a local computing device of the user as described above. This executed application may instruct the user to take active steps in response to a poor or moderate heart health score. For example, the instructions to the user may be to make a corrective measure such as to modify his or her diet, exercise pattern, sleep pattern, or the like. Alternatively or in combination, the instructions to the user may be to take a further step such as to take an electrocardiogram (e.g. to verify the presence of an arrhythmia), enroll in an electrocardiogram over-read service, or schedule an appointment with a physician or other medical specialist. If the heart health score is below a desired threshold for good heart health, the executed application may link the user to a second execute application with further application features. Alternatively or in combination, these further features may be unlocked on the first executed application if the heart health score is below the threshold. In at least some cases, a prescription or verification from a medical professional may also be required to unlock the further application features.

FIG. **8** shows screenshots of the executed application. The further features unlocked may include the ability to read electrocardiogram (ECG) data from a sensor coupled to the local computing device and display the electrocardiogram (ECG) in real-time and/or detect and alert for atrial fibrillation based on the electrocardiogram (ECG) in real-time (e.g. as described in U.S. application Ser. Nos. 12/796,188, 13/108,738, 13/420,540, and 13/964,490). As shown in FIG. **8**, these further features may include an electrocardiogram (ECG) over-read service such as that described in U.S. application Ser. No. 14/217,032. The first executed application may comprise a consumer software application and the second executed application may comprise a medical professional or regulated software application or set of features of the first executed application. As described herein and shown in FIG. **8**, the executed application may provide a dash board to track the heart health of the user and show risk factors which may be monitored and tracked by the user. The dash board may be provided with further features such as that described in U.S. Ser. No. 61/915,113 (filed Dec. 12, 2013).

FIG. **9** shows a method **900** for cardiac disease and rhythm management, which may, for example, be implemented with

the system **100** described herein. In a step **902**, a user or subject is provided access to a cardiac disease and/or rhythm management system such as system **100**. Step **902** may comprise prescribing the use of the system **100** for the user or subject. In a step **904**, the user or subject is provided one or more biometric sensors. These biometric sensor(s) may couple to a computing device of the user or subject, e.g. a personal desktop computer, a laptop computer, a tablet computer, a smartphone, etc., and associated software loaded thereon.

In a step **906**, the user or subject downloads the cardiac disease and/or rhythm management system software onto their computing device. For example, the system software may comprise a mobile software application (“mobile app”) downloaded from the Apple App Store, Google Play, Amazon Appstore, BlackBerry World, Nokia Store, Windows Store, Windows Phone Store, Samsung Apps Store, and the like. The downloaded system software, e.g. mobile app **101a**, may be configured to interface with the biometric sensors provided to the user or subject in the step **154**.

In a step **908**, personal information input to the cardiac disease management system is received. For example, the user or subject may enter his or her gender, height, weight, diet, disease risk factors, etc. into the mobile app **101a**. Alternatively or in combination, this personal information may be input on behalf of the user or subject, for example, by a physician of the user or subject.

In a step **910**, biometric data is received from the biometric sensors provided to the user or subject. For example, the system **100** and the mobile app **101a** may receive ECG data and heart rate from handheld sensor **103**, activity data from wrist-worn activity sensor **105**, blood pressure and heart rate data from mobile blood pressure monitor **107a**, and other data such as weight and body fat percentage data from a “smart” scale in communication with the local computing device **101**.

In a step **912**, a cardiac health score is generated. The cardiac health score can be generated by considering and weighing one or more influencing factors including the incidence of atrial fibrillation or arrhythmia as detected by the handheld ECG monitor, the heart rate of the user or subject, the activity of the user or subject, hours of sleep and rest of the user or subject, blood pressure of the user or subject, etc. Often, the incidence of atrial fibrillation or arrhythmia will be weighed the most. The cardiac health score may be generated by a physician or a machine learning algorithm provided by the remote server or cloud-based service **113**, for example. A plurality of users and subject may concurrently use the cardiac health and/or rhythm management system **100** and the machine learning algorithm may, for example, consider population data and trends to generate an individual user or subject’s cardiac health score.

In a step **914**, one or more recommendations or goals is generated for the user or subject based on or in response to the generated cardiac health score. These recommendation(s) and/or goal(s) may be generated automatically based on or in response to the biometric and personal information of the user or subject. For example, the machine learning algorithm may generate these recommendation(s)/goal(s). Alternatively or in combination, a physician or other medical specialist may generate the recommendation(s) and/or goal(s), for example, based on or in response to the biometric and personal information of the user or subject. The physician or other medical professional may access the patient data through the Internet as described above.

In a step **916**, the patient implements many if not all of the recommendation(s) and/or goal(s) provided to him or her. And in a step **916**, steps **908** to **916** may be repeated such that

the user or subject may iteratively improve their cardiac health score and their overall health.

Although the above steps show method **900** of managing cardiac disease and/or rhythm in accordance with many embodiments, a person of ordinary skill in the art will recognize many variations based on the teaching described herein. The steps may be completed in a different order. Steps may be added or deleted. Some of the steps may comprise sub-steps. Many of the steps may be repeated as often as beneficial to the user or subject.

One or more of the steps of the method **900** may be performed with circuitry, for example, one or more of a processor or a logic circuitry such as a programmable array logic for a field programmable gate array. The circuitry may be programmed to provide one or more of the steps of the method **900**, and the program may comprise program instructions stored on a non-transitory computer readable medium or memory or programmed steps of the logic circuitry such as the programmable array logic or the field programmable gate array, for example.

In some embodiments, the heart rate information (or an extracted portion of HR information) may be used to compare to a database of similar information that has been correlated with cardiac events. For example, heart rate information may be compared to a database of HR information extracted for ECG recordings of patients known to be experiencing cardiac problems. Thus, patterns of heart rate information taken from a subject may be compared to patterns of cardiac information in a database. If there is a match (or a match within a reasonable closeness of fit), the patient may be instructed to record an ECG, e.g. using an ambulatory ECG monitor. This may then provide a more detailed view of the heart. This method may be particularly useful, as it may allow recording and/or transmission and/or analysis of detailed electrical information about the heart at or near the time (or shortly thereafter) when a clinically significant cardiac event is occurring. Thus, the continuous monitoring may allow a subject to be alerted immediately upon an indication of the potential problem (e.g. an increase in HRV suggestive of a cardiac dysfunction). This may allow the coupling of continuous HR monitoring with ECG recording and analysis for disease diagnosis and disease management.

FIG. **10** illustrates one variation of a method for monitoring a subject to determine when to record an electrocardiogram (ECG). In FIG. **10**, a subject is wearing a continuous heart rate monitor (configured as a watch **1010**, including electrodes **1016**), shown in step **1002**. The heart rate monitor transmits (wirelessly **1012**) heart rate information that is received by the smartphone **1018**, as shown in step **1004**. The smartphone includes a processor that may analyze the heart rate information **1004**, and when an irregularity is determined, may indicate **1006** to the subject that an ECG should be recorded. In FIG. **10**, an ambulatory ECG monitor **1014** is attached (as a case having electrodes) to the phone **1018**. The user may apply the ECG monitor as to their body (e.g. chest, between arms, etc.) **1008** to record ECGs that can then be saved and/or transmitted for analysis.

FIGS. **11** and **11A** show screenshots of an atrial fibrillation dashboard **1100** of a user interface for the cardiac disease and/or rhythm management system **100**. FIG. **11** shows a top portion **1100a** of the atrial fibrillation dashboard **1100** while FIG. **10A** shows a bottom portion **1100b** of the atrial fibrillation dashboard **1100**.

The top portion **1100a** of the atrial fibrillation dashboard **1100** as shown in FIG. **10** may display the current cardiac health score of the user or subject, a recent best cardiac health score of the user or subject, and a completion percentage of

recommendation(s) and/or goal(s) for the user or subject. The user or subject may tap any one of the cardiac health score displays or the recommendation(s) and/or goal(s) displays to access more detailed information regarding the calculated health score(s) or recommendation(s) and/or goal(s), respectively. The top portion **1100a** may also show an ECG of the user or subject and a button which may be tapped to record the ECG of the user or subject for the day. As discussed with reference to FIG. 1, the ECG may be recorded with a handheld sensor **103** in communication with the local computing device **100**. The top portion **1000a** may also show the number of atrial fibrillation episodes and the average duration of these atrial fibrillation episodes. This number and duration may be generated automatically by software or logic of the mobile app **101a** based on or in response to the ECG measurements taken by the user or subject. Alternatively or in combination, a physician may access the atrial fibrillation dashboard **1100** of an individual user or subject, evaluate his or her ECGs, and provide the number of atrial fibrillation episodes and their duration to the mobile app **101a** or other software loaded on the local computing device **101** of the user or subject. The shortest and longest durations of the atrial fibrillation episodes may also be shown by the top portion **1100a** as well as the user or subject's daily adherence to a medication regime.

The bottom portion **1100b** of the atrial fibrillation dashboard **1100** as shown in FIG. 10A may display one or more influencers which influence how the cardiac health score is generated. These influencers may include, for example, caffeine intake, alcohol intake, stress levels, sleep levels, weight, nutrition, fitness and activity levels, and blood pressure. Data for these influencers may be input automatically by one or more biometric sensors coupled to the local computing device **101** and/or the mobile app **101a**. Alternatively or in combination, the data for these influencers may be input manually by the user or subject by tapping on the respective influencer display. For example, tapping on the blood pressure display area may cause a slider input **1100c** for blood pressure to pop up. The user or subject may use the slider to enter and save his or her blood pressure for the day. Similar pop-ups or user-selected inputs may be provided for the other influencers. For example, the user or subject may enter his or her daily caffeine or alcohol intake, stress and sleep levels, nutrition levels, or activity and fitness levels (e.g. low/bad, medium/so-so, or high/good based on the user's age, gender, height, weight, etc. as can be indicated by an instruction page of the mobile app **101a**). The influencer displays may also show the goal progression of the user or subject.

FIGS. 12 and 12A show screenshots of a goals and recommendations page **1200** of the cardiac disease and rhythm management system interface or mobile app **101a**. A top portion **1200a** of the goals and recommendations page **1100** may comprise a listing of 7-day goals for the user or subject. The top portion **1200a** may further comprise everyday goals for the user or subject which often cannot be removed or changed. The user or subject can check off these goals or recommendations as he or she meets them. The top portion **1200a** may track goal completion percentage over a 7-day period. The user or subject can set the same goals for the next day and/or set new goals.

A bottom portion **1200b** of the goals and recommendations page **1200** may comprise a listing of new goals which the user or subject may add. The new goals may be categorized into goals or recommendations for atrial fibrillation management, stress management, and/or other categories. For example, goals for atrial fibrillation management may include taking daily medications, reducing caffeine intake, and reducing alcohol intake. And, goals for stress management may

include meditate for 5 minutes daily, take blood pressure reading daily, and getting at least 7 hours of sleep nightly. Using the goals and recommendations page **1200**, the user or subject can set their goals for the week. One or more of these goals may be automatically recommended to the user or subject or be recommended by a physician having access to the dashboard **1100**. For example, goals may be recommended based on last week's progress. The completion of recommended goals can result in the user or subject earning more "points," in effect gamifying health and cardiac rhythm management for the user or subject. Alternatively or in combination, the goals may be set by a physician having access to the dashboard **1100**.

FIG. 13 shows a screenshot of a user's local computing device notifying the user with a pop-up notice **1300** to meet their daily recommendations and goals. By tapping on the pop-up notice, **1300**, the user or subject can be taken to the atrial fibrillation dashboard where the user or subject can update or otherwise manage their cardiac health.

FIG. 14 shows an embodiment comprising a smart watch **1400** which includes at least one heart rate monitor **1402** and at least one activity monitor **1404**. One or more processors are coupled to one or more non-transitory memories of the smart watch and configured to communicate with the heart rate monitor **1402** and the activity monitor **1404**. The one or more processors are further coupled to an output device **1408**. Processor executable code is stored on the one or more memories and when executed by the one or more processors causes the one or more processors to determine if heart rate and activity measurements represent an advisory condition for recording an ECG, and generate and send notification signals through the output device **1408** when an advisory condition for recording an ECG is determined.

For example, presently available smart watches include motion sensors such as pedometers. Pedometers can be based on an accelerometer or electromechanical mechanism such as a pendulum, magnetic reed proximity switch, and a spring suspended lever arm with metal-on-metal contact. Modern accelerometers are often small micro electro-mechanical systems and are well known by those skilled in the art. Heart rate monitors are readily available with smart phones as well as smart watches. One type uses an optical sensor to detect the fluctuation of blood flow. The signal can be amplified further using, for example, a microcontroller to count the rate of fluctuation, which is actually the heart rate.

An advisory condition for recording an ECG may occur due to, for example, large continuing fluctuations in heart rate. An advisory condition for recording an ECG can also occur when a measured heart rate increases rapidly without a corresponding increase in activity monitored by, for example, an accelerometer. By comparing measured heart rate changes with measured activity changes, the presently disclosed software or "app" minimizes false alarms are minimized. ECG devices are described in U.S. Ser. No. 12/796,188, filed Jun. 8, 2010, now U.S. Pat. No. 8,509,882, hereby expressly incorporated herein by reference in its entirety. The ECG device can be present in a smart watch band or a smart phone. In one embodiment, the ECG device includes an electrode assembly configured to sense heart-related signals upon contact with a user's skin, and to convert the sensed heart-related signals to an ECG electric signal. The ECG device transmits an ultrasonic frequency modulated ECG signal to a computing device such as, for example, a smartphone. Software running on the computing device or smartphone digitizes and processes the audio in real-time, where the frequency modulated ECG signal is demodulated. The ECG can be further processed using algorithms to calculate heart rate and identify arrhythmias.

The ECG, heart rate, and rhythm information can be displayed on the computer or smartphone, stored locally for later retrieval, and/or transmitted in real-time to a web server via a 2G/3G/4G, WiFi or other Internet connection. In addition to the display and local processing of the ECG data, the computer or smartphone can transmit, in real-time, the ECG, heart rate and rhythm data via a secure web connection for viewing, storage and further analysis via a web browser interface.

In another embodiment, the converter assembly of an ECG device is integrated with, and electrically connected to the electrode assembly and is configured to convert the electric ECG signal generated by electrode assembly to a frequency modulated ECG ultrasonic signal having a carrier frequency in the range of from about 18 kHz to about 24 kHz. It is sometimes desirable to utilize a carrier frequency in the 20 kHz to 24 kHz range. The ultrasonic range creates both a lower noise and a silent communication between the acquisition electronics and the computing device such as the smartphone, notebook, smart watch and the like.

A kit can include downloadable software such as an “app” for detecting an advisory condition for recording an ECG and an ECG device. The ECG device can be present on a watch band for replacing a specific band on a smart watch. The ECG device can also be provided on a smart phone back plate for replacing an existing removable smartphone back. In another configuration, the ECG device is usable as a smartphone protective case.

Software on the smartphone or smart watch can also combine data and signals from other sensors built into the smartphone or smart watch such as a GPS.

While preferred embodiments of the present disclosure have been shown and described herein, it will be obvious to those skilled in the art that such embodiments are provided by way of example only. Numerous variations, changes, and substitutions will now occur to those skilled in the art without departing from the subject matter described herein. It should be understood that various alternatives to the embodiments of the subject matter described herein may be employed in practicing the subject matter described herein. It is intended that the following claims define the scope of the disclosure and that methods and structures within the scope of these claims and their equivalents be covered thereby.

What is claimed is:

1. A method of evaluating health of a heart of a user, the method comprising
 - receiving heart rate information from a heart rate sensor located on a surface of a wearable computing device worn by a user;
 - transmitting said heart rate information to a processor of said wearable computing device;
 - determining an irregular heart rate variability (HRV) value, with said processor, in response to said received heart rate information; and
 - sensing an electrocardiogram of said user with said wearable computing device in response to said irregular HRV value.
2. The method of claim 1, comprising generating a Heart Health Score based on said determined HRV value and on or more of said sensed electrocardiogram, a determined presence of an arrhythmia, a number of premature beats, a frequency of said premature beats, and a Heart Rate Turbulence (HRT) value.
3. The method of claim 2, further comprising displaying said Heart Health Score with a display of said wearable computing device.

4. The method of claim 1, wherein said heart rate information is measured by said heart rate sensor continuously for at least 2 hours.

5. The method of claim 4, wherein said heart rate information is measured by said heart rate sensor continuously for at least 7 days.

6. The method of claim 2, wherein said Heart Health Score ranges from a low of 1 to a high of 100.

7. The method of claim 1, wherein said wearable computing device comprises a smartband or a smartwatch.

8. The method of claim 2, wherein said heart health score is transmitted to a remote server or cloud server, and wherein said heart health score is accessible on said remote server or said cloud server to other users.

9. The method of claim 1, wherein said step of sensing said electrocardiogram comprises providing an indication to said user to sense said electrocardiogram.

10. The method of claim 9, wherein said indication comprises an alert.

11. The method of claim 1, comprising providing said user with an indication to input physiologic information associated with said received heart rate information into said wearable computing device.

12. A method of determining a presence of an arrhythmia of a user, said method comprising

- receiving heart rate information from a heart rate sensor located on a surface of a wearable computing device worn by a user;
- transmitting said heart rate information to a processor of said wearable computing device;
- determining an heart rate variability (HRV) value, with said processor, in response to said received heart rate information;
- determining a presence of an atrial fibrillation of said user in response to said determined heart rate variability (HRV) value; and
- sensing an electrocardiogram with said wearable computing device in response to said presence of said atrial fibrillation.

13. The method of claim 12, further comprising displaying to said user an alert on said display of said wearable device if said presence of said atrial fibrillation is determined.

14. The method of claim 12, comprising receiving heart rate information from a plurality of heart rate sensors coupled to a plurality of users.

15. The method of claim 14, further comprising training a machine learning algorithm to recognize a presence of an atrial fibrillation of an individual user of the plurality of users in response to said heart rate information from the plurality of heart rate sensors.

16. The method of claim 15, wherein said plurality of users have been previously identified as having atrial fibrillation or as having no atrial fibrillation.

17. The method of claim 15, wherein determining said presence of said atrial fibrillation of said user in response to said determined heart rate (HRV) value comprises determining said presence of said atrial fibrillation of said user using said trained machine learning algorithm.

18. The method of claim 12, comprising receiving activity level data associated with said received heart rate information from an activity level sensor on said wearable computing device.

19. The method of claim 12, wherein said presence of said atrial fibrillation is determined in part by comparing said determined HRV value with said received activity level.

20. The method of claim 19, wherein said step of sensing said electrocardiogram comprises providing an indication to said user to sense said electrocardiogram.

21. The method of claim 20, wherein said indication comprises an alert.

5

* * * * *

专利名称(译)	用于心律失常追踪和评分的方法和系统		
公开(公告)号	US9420956	公开(公告)日	2016-08-23
申请号	US14/569513	申请日	2014-12-12
[标]申请(专利权)人(译)	阿利弗克公司		
申请(专利权)人(译)	ALIVECOR INC.		
当前申请(专利权)人(译)	ALIVECOR INC.		
[标]发明人	GOPALAKRISHNAN RAVI KORZINOV LEV WANG FEI THOMSON EUAN SRIVASTAVA NUPUR DAWOOD OMAR ABUZEID IMAN ALBERT DAVID E		
发明人	GOPALAKRISHNAN, RAVI KORZINOV, LEV WANG, FEI THOMSON, EUAN SRIVASTAVA, NUPUR DAWOOD, OMAR ABUZEID, IMAN ALBERT, DAVID E		
IPC分类号	A61B5/02 A61B5/04 A61B5/0205 A61B5/024 A61B5/0245 A61B5/046 A61B5/00 A61B5/021 A61B5/0452 A61B5/11 G06F19/00		
CPC分类号	A61B5/02405 A61B5/0245 A61B5/02416 A61B5/046 A61B5/7264 A61B5/6898 G06F19/3418 A61B5/0022 A61B5/02055 A61B5/7275 A61B5/681 A61B5/021 A61B5/02438 A61B5/0452 A61B5/1118 G06F19/322 G06F19/3487 A61B5/746 G06F19/3481 G16H10/60 G16H15/00 G16H20/40 G16H50/20 G16H50/30 G06F19/00 G16H40/63 G16H40/67		
代理机构(译)	WILSON SONSINI盈丰 & ROSATI		
优先权	61/915113 2013-12-12 US 61/953616 2014-03-14 US 61/969019 2014-03-21 US 61/970551 2014-03-26 US 62/014516 2014-06-19 US		
其他公开文献	US20150164349A1		
外部链接	Espacenet USPTO		

摘要(译)

提供以心律失常或心房颤动跟踪为中心的仪表板。仪表板包括心脏或心脏健康评分，其可以响应于来自用户的数据（例如他们的ECG和其他个人信息以及心脏健康影响因素）来计算。仪表板还向用户提供建议或目标，例如每日目标，供用户满足并由此改善他们的心脏或心脏健康评分。这些目标和建议可以由用户或医疗专业人员设定，并且随着他或她的心脏或心脏健康评分改善或以其他方式改变而定期更新。仪表板通常从在用户的智能手机或平板电脑上提供的应用程序显示。

