



US 20150216474A1

(19) **United States**
(12) **Patent Application Publication**
Riley et al.

(10) **Pub. No.: US 2015/0216474 A1**
(43) **Pub. Date: Aug. 6, 2015**

(54) **APPARATUSES FOR SUPPORTING AND MONITORING A CONDITION OF A PERSON**

A61B 5/0476 (2006.01)
G08B 21/04 (2006.01)
A61B 5/0205 (2006.01)
A61B 5/11 (2006.01)

(71) Applicant: **Hill-Rom Services, Inc.**, Batesville, IN (US)

(52) **U.S. CL.**
CPC *A61B 5/4809* (2013.01); *A61B 5/0205* (2013.01); *A61B 5/1118* (2013.01); *A61B 5/4815* (2013.01); *A61B 5/0476* (2013.01); *A61B 5/1115* (2013.01); *A61B 5/7282* (2013.01); *A61B 5/6891* (2013.01); *G08B 21/0453* (2013.01); *G08B 21/06* (2013.01); *A61B 5/02405* (2013.01)

(72) Inventors: **Carl W. Riley**, Milan, IN (US); **Timothy J. Receveur**, Guilford, IN (US); **David L. Ribble**, Indianapolis, IN (US)

(21) Appl. No.: **14/689,588**

(22) Filed: **Apr. 17, 2015**

Related U.S. Application Data

(63) Continuation of application No. 14/011,833, filed on Aug. 28, 2013, now Pat. No. 9,044,204, which is a continuation of application No. 12/881,285, filed on Sep. 14, 2010, now Pat. No. 8,525,680.

(60) Provisional application No. 61/243,714, filed on Sep. 18, 2009, provisional application No. 61/243,741, filed on Sep. 18, 2009, provisional application No. 61/243,806, filed on Sep. 18, 2009, provisional application No. 61/243,825, filed on Sep. 18, 2009.

Publication Classification

(51) **Int. Cl.**
A61B 5/00 (2006.01)
G08B 21/06 (2006.01)

(57) **ABSTRACT**

A person monitoring system is operable to predict the onset of an adverse condition of a person. The system receives first information corresponding to a feature of a person support apparatus and second information corresponding to a physiological characteristic of the person. The system calculates a condition score as a function of the first and second information. In some instances, the system alerts a caregiver if the condition score exceeds a predetermined threshold. Alternatively or additionally, the person monitoring system alerts a caregiver when a person supported on a person support apparatus is regaining consciousness by monitoring one or more of a change in position, a heart rate, and a respiration rate. A person monitoring system that monitors a person's quality of sleep and presents information concerning the quality of sleep to one or more interested parties is also disclosed.

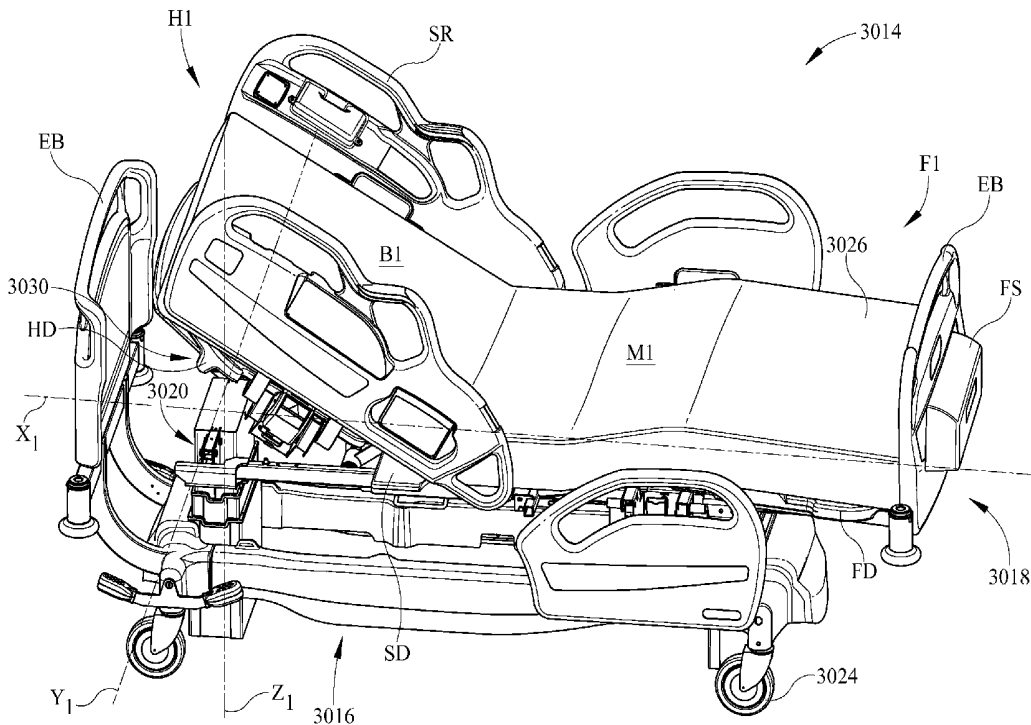

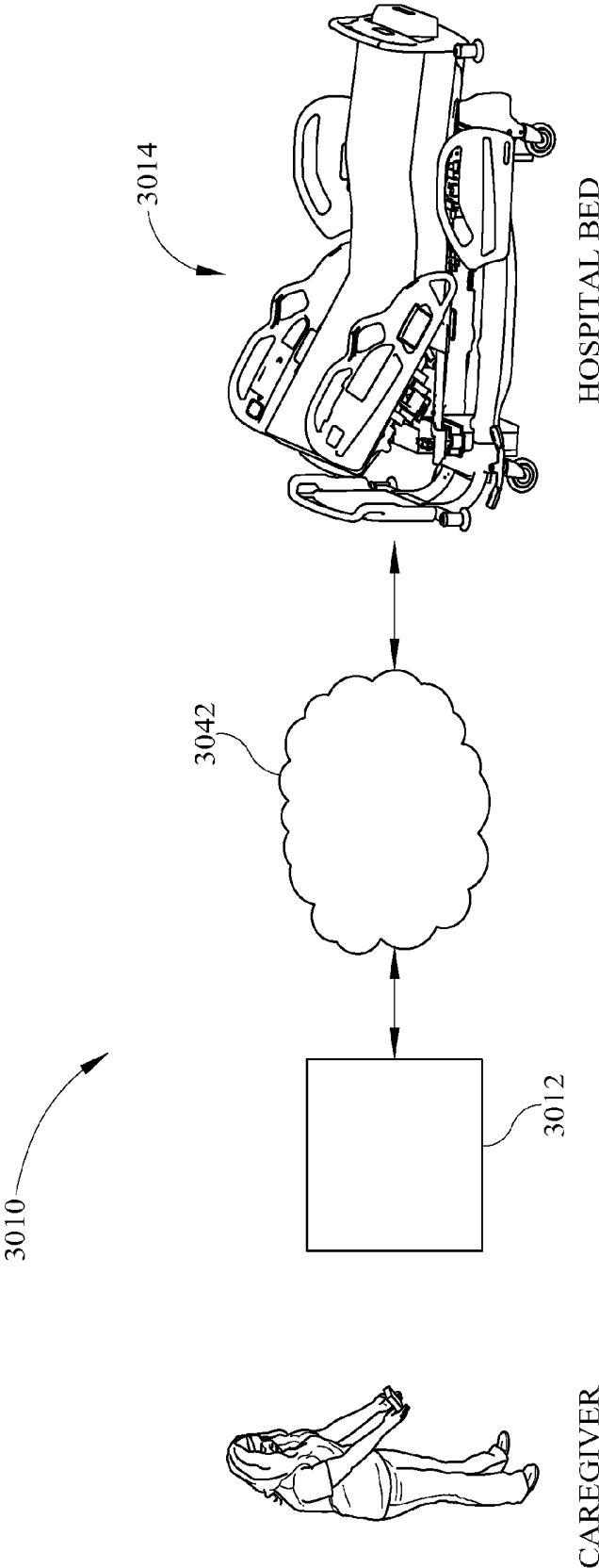

FIG. 1

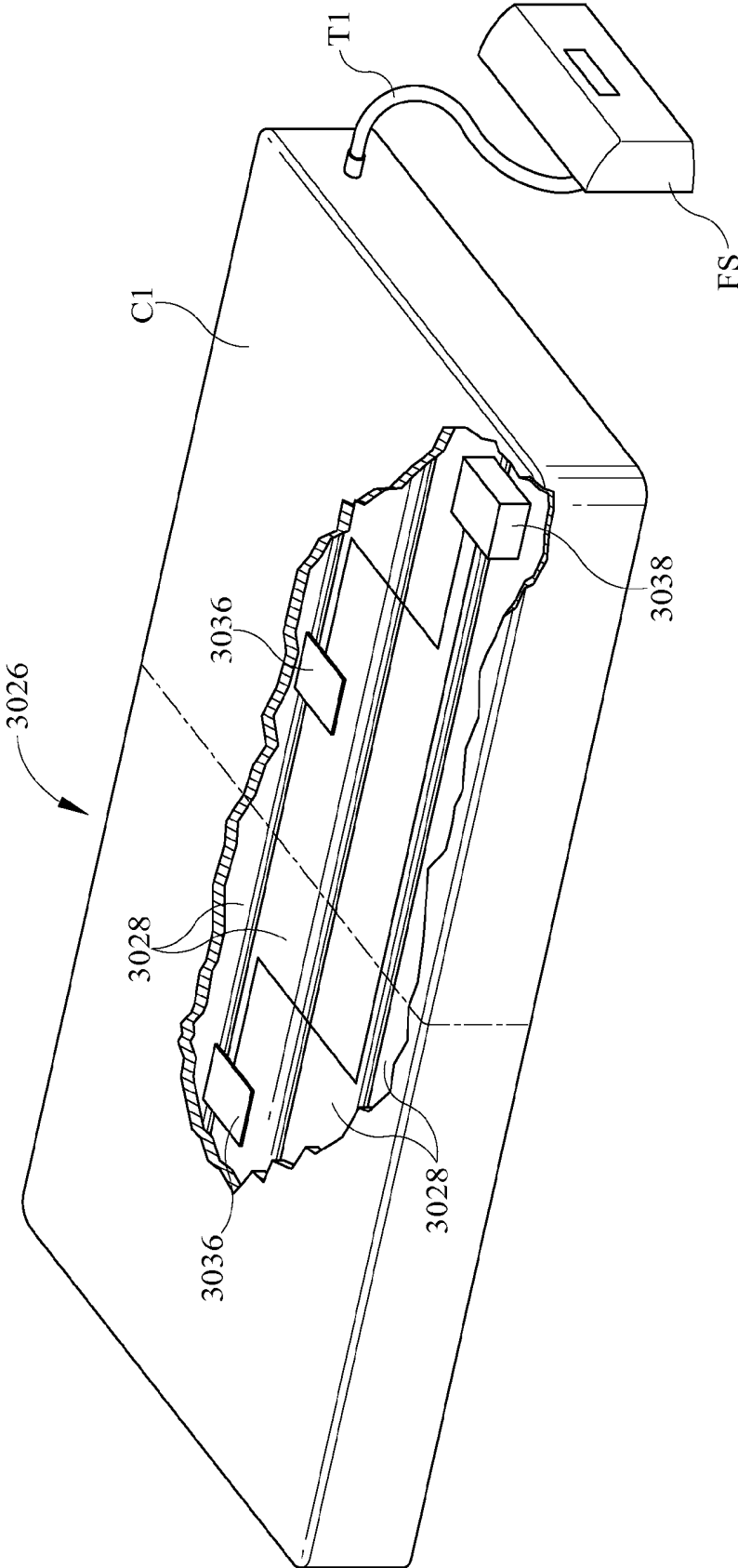

FIG. 3

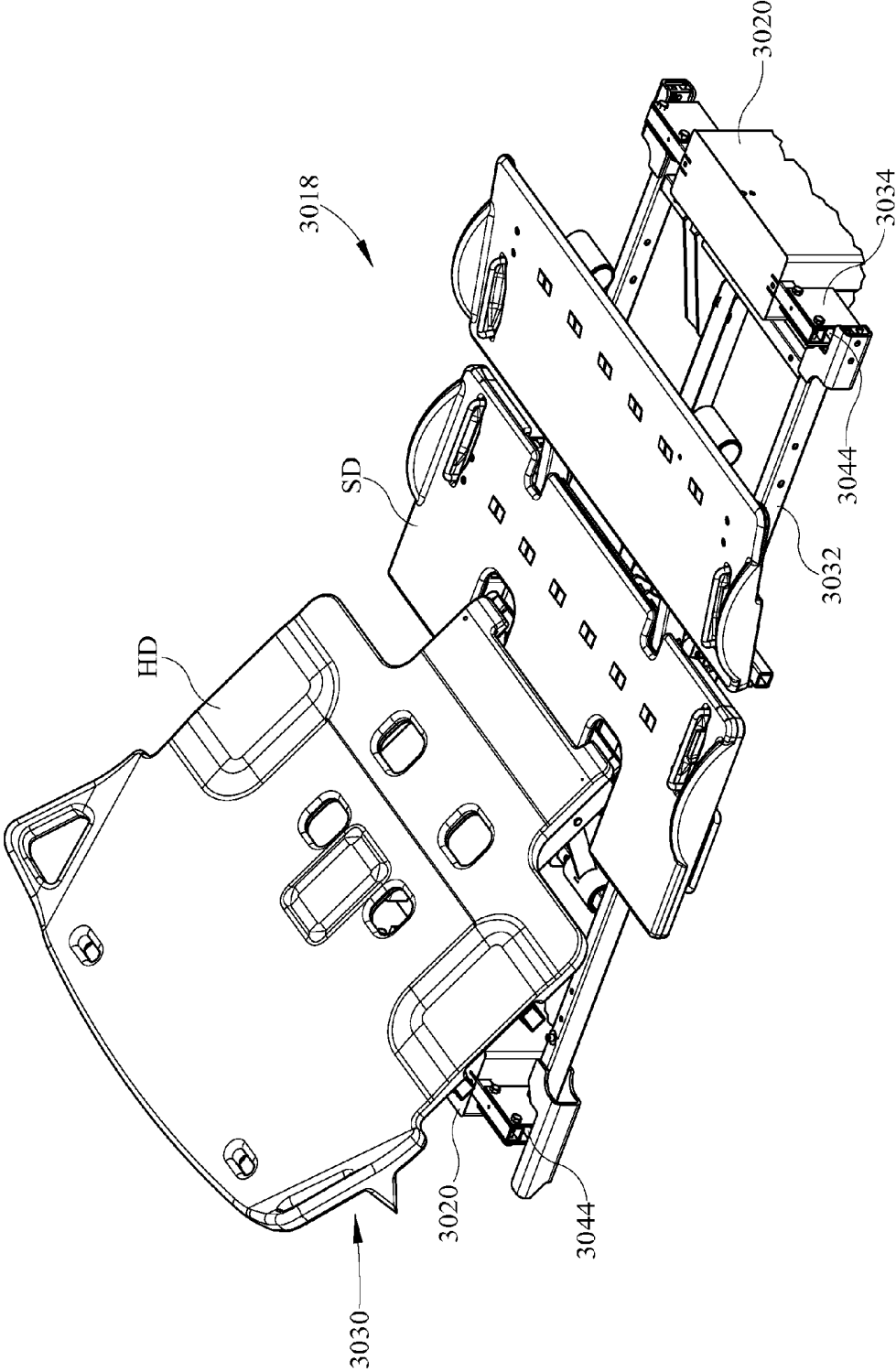

FIG. 4

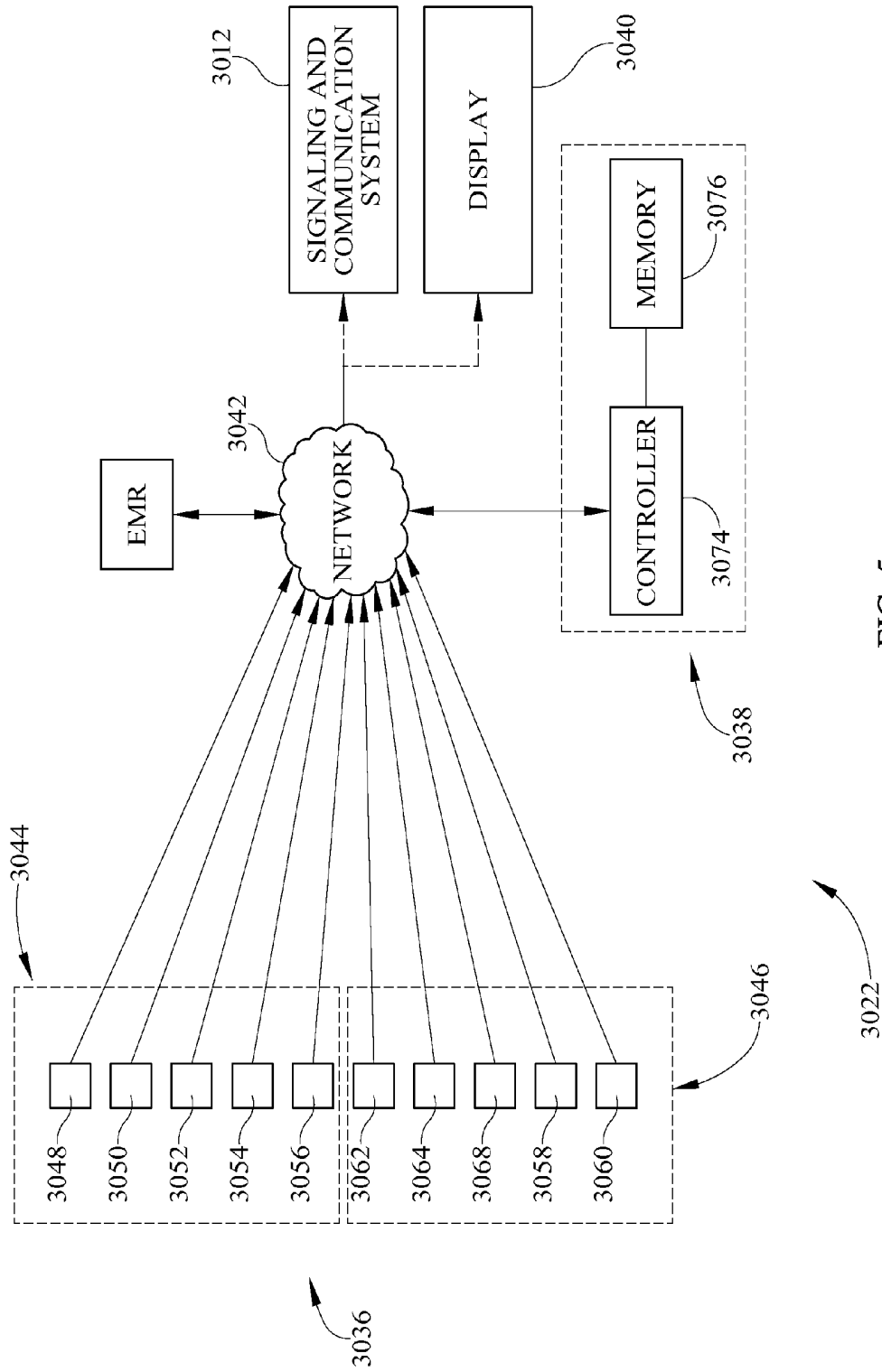

FIG. 5

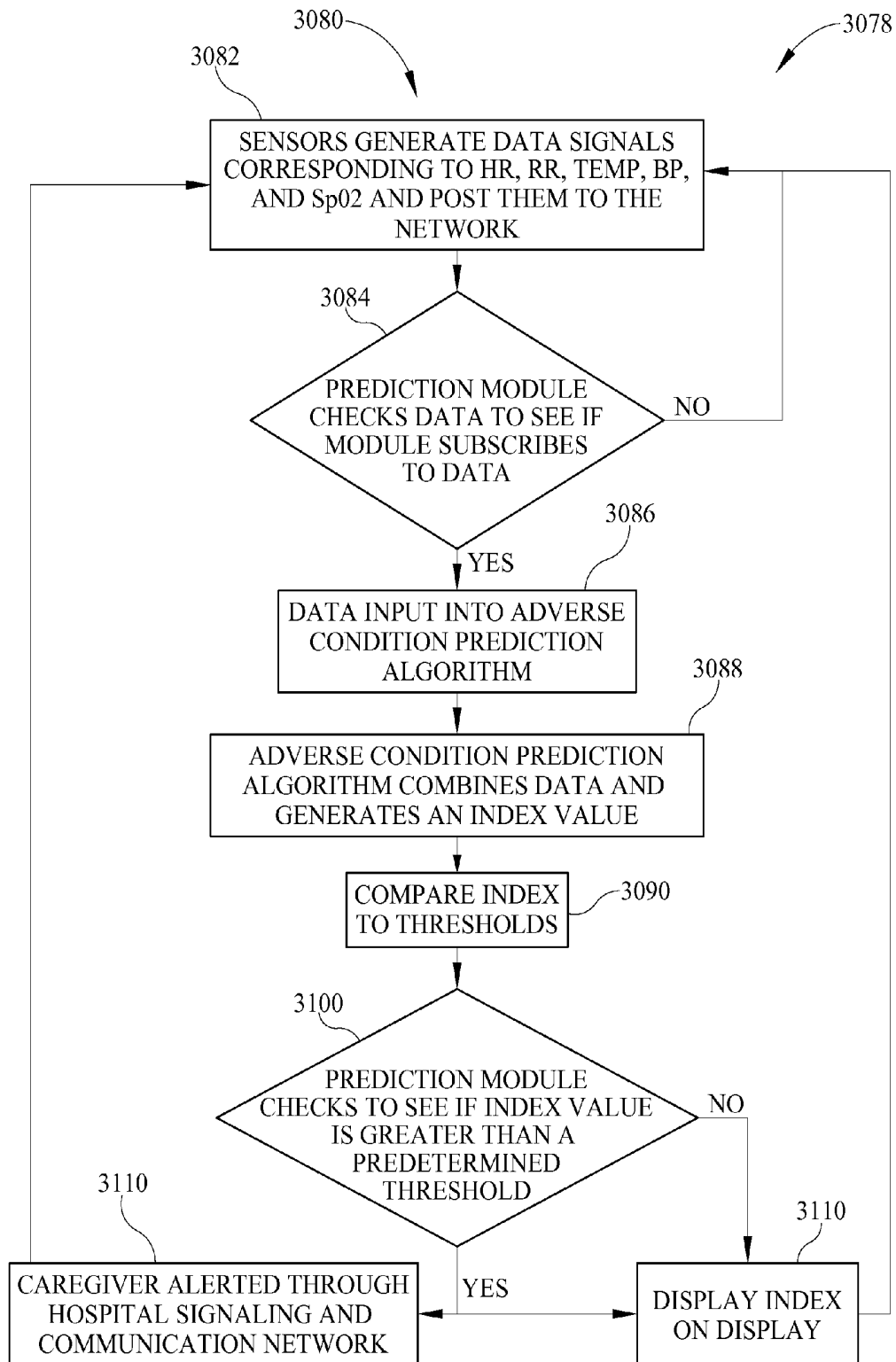

FIG. 6

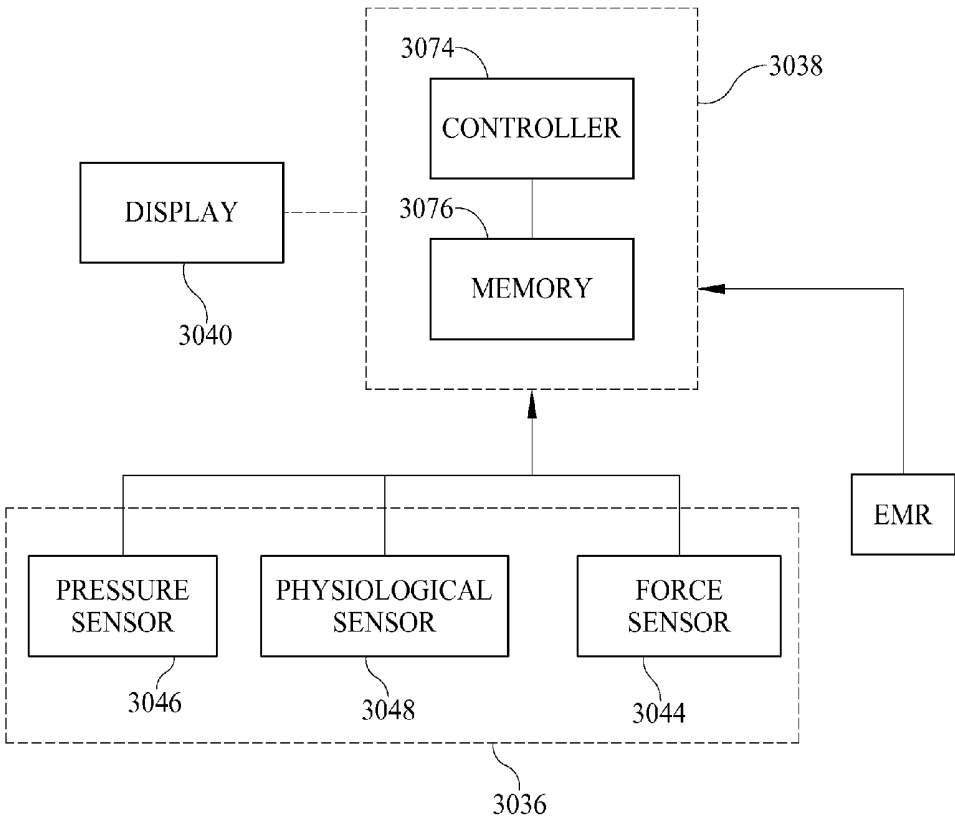

FIG. 7

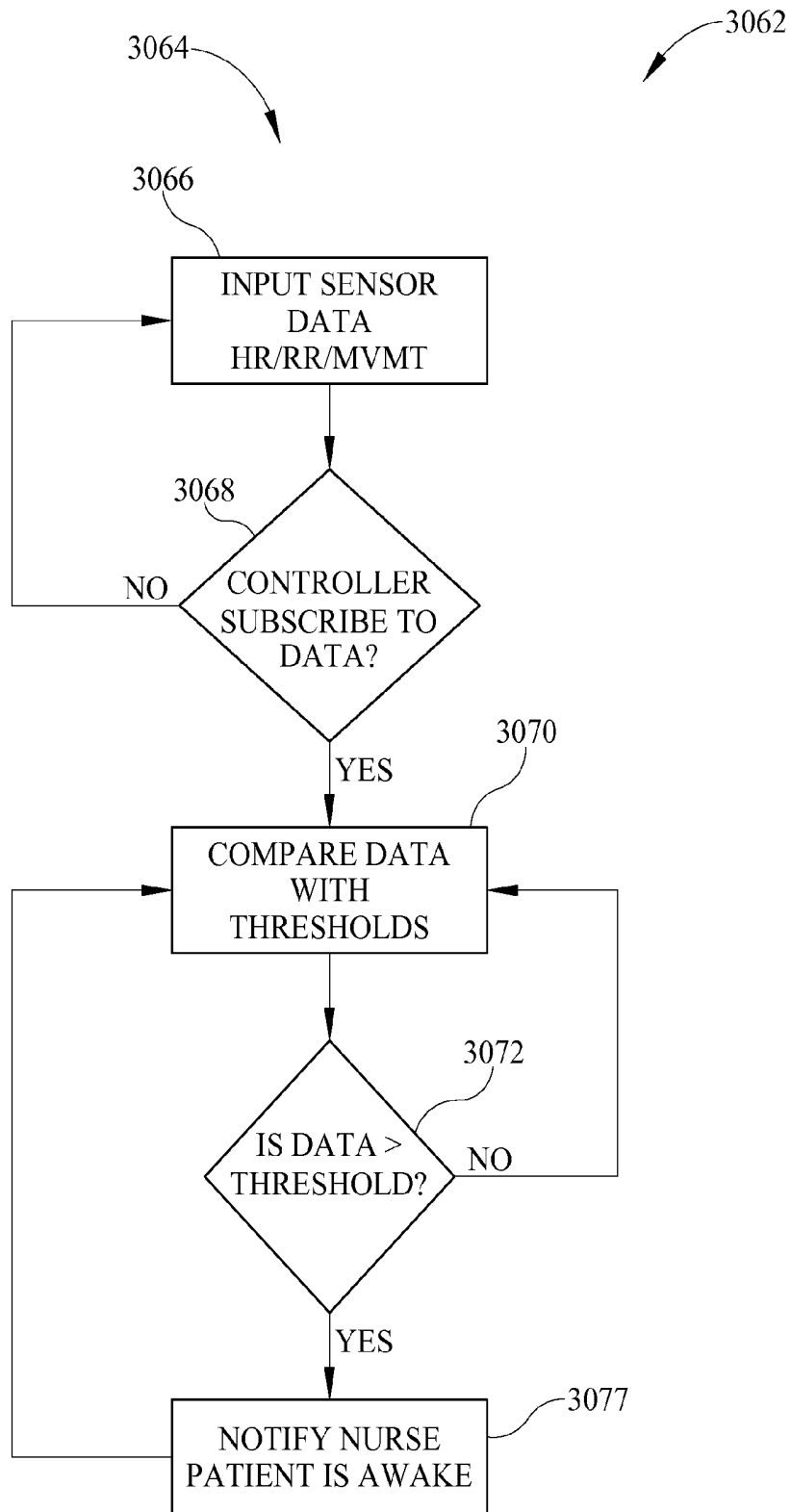

FIG. 8

APPARATUSES FOR SUPPORTING AND MONITORING A CONDITION OF A PERSON

CROSS-REFERENCE TO RELATED APPLICATIONS

[0001] The present application is a continuation of U.S. application Ser. No. 14/011,833, filed Aug. 28, 2013, now U.S. Pat. No. _____, which is a continuation of U.S. application Ser. No. 12/881,285, filed Sep. 14, 2010, now U.S. Pat. No. 8,525,680, which claims the benefit, under 35 U.S.C. §119(e), of U.S. Provisional Application Nos. 61/243,714; 61/243,741; 61/243,806; and 61/243,825; each of which was filed Sep. 18, 2009 and each of which is hereby incorporated by reference herein.

[0002] The present application relates to U.S. application Ser. No. 12/881,252, filed Sep. 14, 2010 and titled "Sensor Control for Apparatuses for Supporting and Monitoring a Person," now published as U.S. Patent Application Publication No. 2011/0068928 A1.

BACKGROUND

[0003] This disclosure relates to person support apparatuses. More particularly, but not exclusively, the present disclosure relates to person support apparatuses that incorporate or are used with vital signs monitoring devices and movement detection systems.

[0004] Person support apparatuses can include beds, chairs, stretchers, seats, mattresses, therapy surfaces, furniture, and the like, or other apparatuses that support a person. Hospital beds and stretchers, hospital mattresses, and wheelchairs are examples of such apparatuses that support persons. Consumer beds, chairs, and furniture are also examples of such person support apparatuses, as are seats for vehicles, businesses, and venues.

[0005] Vital signs monitors monitor one or more physiological parameters of a person, such as body temperature, pulse rate, heart rate, blood pressure, and respiratory rate, as well as other body signs, such as end-tidal CO₂, SpO₂ (saturation of oxygen in arterial blood flow, sometimes referred to as pulse oximetry), and other indicators of the person's physiological state. Movement and/or position detection systems monitor the movement of a person to determine if they are attempting to exit the support apparatus. Movement and/or position detection systems are sometimes included as part of a hospital bed.

[0006] While various systems have been developed, there is still a need for further contributions and improvements in these areas of technology, particularly with regard to predicting the onset of an adverse condition prior to the occurrence of the condition.

SUMMARY

[0007] The present disclosure includes one or more of the features recited in the appended claims and/or the following features which, alone or in any combination, may comprise patentable subject matter.

[0008] A person monitor system may include a person support apparatus configured to support a person. The person support apparatus may have at least one first sensor sensing first information corresponding to a feature of the person support apparatus. The system may have a second sensor sensing second information corresponding to a physiological characteristic of the person. A controller of the monitor sys-

tem may receive the first information sensed by the first sensor and the second information sensed by the second sensor. The controller may calculate a condition score as a function of the first information and the second information. A communication system may be coupled to the controller. The communication system may alert a caregiver in response to the condition score violating a predetermined threshold condition.

[0009] The person support apparatus may comprise a hospital bed, for example. The first sensor may be included as part of a patient position monitoring system of the hospital bed and the first information may include patient movement information. In some embodiments, the first sensor may include at least one load cell. The first sensor may be located inside an interior region of a mattress of the hospital bed. The second sensor may also be located inside an interior region of the mattress.

[0010] The condition score may comprise a modified early warning score (MEWS) having different integers assigned to a portion of the MEWS depending upon whether a patient is alert (A), responsive to voice (V), responsive to pain (P), or unresponsive (U). The patient movement information may be used by the controller to automatically assign an appropriate integer corresponding to the A portion or the U portion of the MEWS.

[0011] The controller may initiate a voice query to the person and, if the person answers the voice query orally or by engaging a user input, then the controller may automatically assign an appropriate integer corresponding to the V portion of the MEWS. The controller may control inflation and deflation of an inflatable cuff or sleeve placed on a limb of the person. If the patient movement information indicates sufficient patient movement by the patient in response to inflation of the cuff or sleeve, then the controller may automatically assign an appropriate integer corresponding to the P portion of the MEWS. The second sensor may comprise a plurality of sensors sensing the person's systolic blood pressure, heart rate, respiration rate, and temperature, each of which is used by the controller to calculate the MEWS.

[0012] The person support apparatus may comprise a hospital bed that includes a graphical display to display the condition score. The graphical display may be, for example, a touchscreen display that is used by a caregiver to control functions of the person support apparatus. The second sensor may include at least one contact sensor that contacts the person and that operates to sense a first physiological condition and at least one contact-less sensor that is spaced from the person and that operates to sense a second physiological condition. The at least one contact sensor and the at least one contact-less sensor may be included as part of the hospital bed. The controller may receive patient information from the patient's electronic medical record (EMR) and the condition score may also be a function of the patient information.

[0013] Also according to this disclosure, a person monitor system may comprise a person support apparatus supporting a person, the person support apparatus having a sensor that senses information regarding at least one of a change in position, a heart rate, and a respiration rate of the person on the person support apparatus, and a controller receiving the information sensed by the sensor, the controller determining if the patient is awake by comparing the information to a predetermined threshold, and the controller initiating an alert to a caregiver in response to the patient becoming awake.

[0014] The controller may determine the person's sleep quality by processing the information. The system may further comprise a display coupled to the controller and displaying data about the person's sleep quality. The display may be mounted to the person support apparatus. The person support apparatus may comprise a hospital bed and the sensor may be included as a part of a patient movement monitoring system of the hospital bed.

[0015] Further according to this disclosure, a person monitor system may include a person support apparatus that may, in turn, have a sensor that senses information regarding at least one of a change in position, a heart rate, and a respiration rate of the person on the person support apparatus. The system may further include a controller that may receive the information sensed by the sensor and that may determine the person's sleep quality by processing the information. A display may also be included and data about the person's sleep quality may be displayed on the display.

[0016] The data about the person's sleep quality may include at least one of time until sleep onset, amount of times awoken during a sleep cycle, amount of times the person exited the person support apparatus during the cycle, amount of movement during the sleep cycle regardless of stage of sleep, amount of time in each stage of sleep, and amount of sleep apnea occurrences. The person support apparatus may comprise a hospital bed to which the display may be mounted.

[0017] Some embodiments may include a control system for a person support system configured to receive input signals from at least one of a sensor and an electronic medical record (EMR), generate a condition score as a function of the input that can correspond to the likelihood of an adverse condition occurring, and alert a caregiver when the condition score exceeds a predetermined threshold.

[0018] Additional features, which alone or in combination with any other feature(s), such as those listed above and/or those listed in the claims, can comprise patentable subject matter and will become apparent to those skilled in the art upon consideration of the following detailed description of various embodiments exemplifying the best mode of carrying out the embodiments as presently perceived.

BRIEF DESCRIPTION OF THE DRAWINGS

[0019] Referring now to the illustrative examples in the drawings, wherein like numerals represent the same or similar elements throughout:

[0020] FIG. 1 is a diagrammatic view of person monitoring system according to one or more principles of the present disclosure;

[0021] FIG. 2 is a perspective side view of the person support apparatus of the person monitoring system of FIG. 1 according to one illustrative embodiment;

[0022] FIG. 3 is a perspective side view of a person support surface that can be supported on the person support apparatus of FIG. 2 according to one illustrative embodiment;

[0023] FIG. 4 is a perspective side view of the upper frame of the person support apparatus of FIG. 2 according to one illustrative embodiment;

[0024] FIG. 5 is diagrammatic view of a control system of the person support apparatus of FIG. 2 according to one illustrative embodiment including a controller and a plurality of sensors;

[0025] FIG. 6 is a flow chart illustrating a procedure that can be executed by the controller of the control system of FIG. 5 according to one illustrative embodiment;

[0026] FIG. 7 is a diagrammatic view of a control system of the person support apparatus of FIG. 2 according to one illustrative embodiment including a controller and a plurality of sensors; and

[0027] FIG. 8 is a flow chart showing a procedure executed by the controller of the control system of FIG. 7 according to one illustrative embodiment.

DETAILED DESCRIPTION

[0028] While the present disclosure can take many different forms, for the purpose of promoting an understanding of the principles of the disclosure, reference will now be made to the embodiments illustrated in the drawings, and specific language will be used to describe the same. No limitation of the scope of the disclosure is thereby intended. Various alterations, further modifications of the described embodiments, and any further applications of the principles of the disclosure, as described herein, are contemplated.

[0029] One illustrative embodiment includes a control system coupled to a person support system configured to receive input signals corresponding to at least one of bed status information, person position, electronic medical record information, and physiological information, generate a condition score corresponding to the likelihood of an adverse condition occurring, and alert a caregiver when the condition score exceeds a predetermined threshold.

[0030] A person monitor system 3010 according to one illustrative embodiment of the current disclosure is shown in FIG. 1. The person monitor system 3010 includes a signaling and communication system 3012 in communication with a person support apparatus 3014. The person monitor system 3010 is configured to provide caregivers with information about a person supported on the person support apparatus 3014 through the signaling and communication system 3012. In one illustrative embodiment, the signaling and communication system 3012 comprises a patient/nurse call system 3012 that, in some embodiments, includes patient stations capable of generating hospital calls and a remote master station which prioritizes and store the calls. One example of such a system is disclosed in U.S. Pat. No. 5,561,412 issued on Oct. 1, 1996 to Novak et al., which is incorporated by reference herein in its entirety. Another example of such a system is disclosed in U.S. Pat. No. 4,967,195 issued on May 8, 2006 to Shipley, which is incorporated by reference herein in its entirety.

[0031] In some embodiments, the signaling and communication system 3012 includes a system 3012 for transmitting voice and data in packets over a network with any suitable number of intra-room networks that can couple a number of data devices to an audio station, where the audio station couples the respective intra-room network to a packet based network. One example of such a system is disclosed in U.S. Pat. No. 7,315,535 issued on Jan. 1, 2008 to Schuman, which is incorporated by reference herein in its entirety. Another example of such a system is disclosed in U.S. Patent Publication No. 2008/0095156 issued on Apr. 24, 2008 to Schuman, which is incorporated by reference herein in its entirety.

[0032] According to some embodiments, the signaling and communication system 3012 includes a patient/nurse call system, a nurse call/locating badge, an electronic medical record (EMR) database, and one or more computers programmed with work-flow process software. One example of such a system is disclosed in U.S. Patent Publication No. 2008/0094207 published on Apr. 24, 2008 to Collins, Jr. et al.,

which is incorporated by reference herein in its entirety. Another example of such a system is disclosed in U.S. Patent Publication No. 2007/0210917 published on Sep. 13, 2007 to Collins, Jr. et al., which is incorporated by reference herein in its entirety. Yet another example of such a system is disclosed in U.S. Pat. No. 7,319,386 published on Jan. 15, 2008 to Collins, Jr. et al., which is incorporated by reference herein in its entirety. It should be appreciated that the workflow process software can be the NaviCare® software available from Hill-Rom Company, Inc. It should also be appreciated that the workflow process software can be the system disclosed in U.S. Pat. No. 7,443,303 issued on Oct. 28, 2008 to Spear et al., which is incorporated by reference herein in its entirety. It should further be appreciated that the badge can be of the type available as part of the ComLinx™ system from Hill-Rom Company, Inc. It should also be appreciated that the badge can also be of the type available from Vocera Communications, Inc.

[0033] According to some embodiments, the remote signaling and communication system **3012** is configured to organize, store, maintain and facilitate retrieval of bed status information, along with the various non-bed calls placed in a hospital wing or ward, and remotely identify and monitor the status and location of the person support apparatus, patients, and caregivers. One example of such a system is disclosed in U.S. Pat. No. 7,242,308 issued on Jul. 10, 2007 to Ulrich et al., which is incorporated by reference herein in its entirety. It should be appreciated that the remote status and location monitoring can be the system disclosed in U.S. Pat. No. 7,242,306 issued on Jul. 10, 2007 to Wildman et al., which is incorporated by reference herein in its entirety. It should also be appreciated that the remote status and location monitoring can be the system disclosed in U.S. Patent Publication No. 2007/0247316 published on Oct. 25, 2007 to Wildman et al., which is incorporated by reference herein in its entirety.

[0034] The person support apparatus **3014** according to one illustrative embodiment of the current disclosure is shown in FIG. 2. The person support apparatus **3014** includes a head section **H1**, where the head and a portion of the torso of a person are to be positioned, and a foot section **F1**, where the feet of a person are to be positioned. The person support apparatus **3014** includes a lower frame **3016** or base **3016**, an upper frame **3018**, a plurality of supports **3020**, and a control system **3022**. It should be appreciated that the person support apparatus **3014** can include only one support **3016**. The lower frame **3016** includes at least one lower frame section supported by casters **3024**. The supports **3020** are lift mechanisms **3020** that define a vertical axis **Z1** which extends through the lower frame **3016** and the upper frame **3018** and are configured to move the upper frame **3018** with respect to the lower frame **3016**. It should be appreciated that the supports **3020** can be at least one fixed column (not shown), if desired. It should also be appreciated that, in some embodiments, the supports **3020** move the upper frame **3018** to a Trendelenburg/reverse Trendelenburg position and/or rotate the upper frame **3014** from side to side with respect to the lower frame **3012**.

[0035] The person support apparatus **3014** supports a person support surface **3026** on the upper frame **3018** as shown in FIGS. 2 and 3. The person support surface **3026** is configured to support a person (not shown) in multiple articulated positions. The person support surface **3026** includes a back portion **B1** and a main portion **M1**. The person support surface **3026** includes an outer cover or ticking **C1** that covers

one or more support sections and/or layers having foam and/or fluid bladders **3028**. In some embodiments, the person support surface **3026** delivers therapy to the person, such as, for example, through sequential inflation/deflation of the fluid bladders **3028**, rapid changes in pressure of the fluid in the fluid bladders **3028**, passing fluid through the person support surface **3026**, and/or various other techniques. For example, in various embodiments, one or more portions of the surface **3026** provide alternating pressure therapy, continuous lateral rotation therapy, low air loss therapy, boost assistance, percussion/vibration therapy, and/or other therapies. It should also be appreciated that, in some embodiments, the person support surface **3026** includes a coverlet (not shown) that overlies another person support surface **3026** and is configured to deliver therapy to a person supported thereon. The person support surface **3026** receives fluid from a fluid supply **FS** connected to the person support surface **3026** by a connecting tube **T1**. In some embodiments, the fluid supply **FS** is a gas blower and is configured to vary at least one of a rate and a temperature of fluid supplied to the person support surface **3026**.

[0036] The upper frame **3018** defines a longitudinal axis **X1** that extends at least the length of the person support apparatus **3014** through the head end **H1** and the foot end **F1** along the lateral center of the upper frame **3018**, and a lateral axis **Y1** that is perpendicular to the longitudinal axis **X1** and extends at least the width of the person support apparatus **3014** through the longitudinal center of the upper frame **3018** as shown in FIGS. 2 and 4. The upper frame **3018** includes a deck **3030**, an intermediate frame **3032**, and an upper frame base **3034** that couples with the supports **3020** and supports the deck **3030** and the intermediate frame **3032**. It should be appreciated that the upper frame **3018** includes a footboard **FB**, a head board **HB**, and/or siderails **SR** in some embodiments. The deck **3030** is comprised of multiple sections, such as, a head deck section **HD**, a seat deck section **SD**, and a foot deck section **FD**, that are pivotably coupled to one another and/or the intermediate frame **3032** and articulate about the lateral axis **Y1**.

[0037] The control system **3022** is configured to control various functions of the person support apparatus **3014** and/or communicate with the signaling and communication system **3012** as shown in FIG. 5. It should be appreciated that the control system **3022** can be configured to be controlled through the signaling and communication system **3012**, if desired. In one illustrative embodiment, the control system **3022** is configured to articulate the deck **3030** with respect to the intermediate frame **3032**. In some embodiments, the control system **3022** is configured to administer therapy to a person supported on the person support apparatus **3014**. According to some embodiments, the control system **3022** is configured to alert caregivers when a person is exiting the person support apparatus **3014**.

[0038] It is contemplated by this disclosure that the control system **3022** is configured to predict the onset of an adverse condition and alert a caregiver. In some embodiments contemplated herein, the control system **2022** is configured to alert caregivers when a person is regaining consciousness. Alerting the caregiver when a person is regaining consciousness can be helpful in instances where the person is unconscious when admitted to a hospital and is, for example, secured to the person support apparatus, being tube fed, has broken or lost a limb, and/or lost their sight, because the person can become anxious upon regaining consciousness

and can cause additional trauma to themselves before a caregiver can arrive to calm them and/or explain what is going on.

[0039] The control system 3022 includes a plurality of sensors 3036, control modules 3038, and a display 3040 as shown in FIG. 5. The sensors 3036 and/or the control modules 3038 are coupled to the upper frame 3018 in some embodiments. It should be appreciated that the sensors 3036 and/or the control modules 3038 can be coupled to the lower frame 3016, supports 3020, and/or incorporated within or coupled to the person support surface 3020 in other embodiments, if desired. In one illustrative embodiment, the sensors 3036, control modules 3038, and the display 3040 are directly connected to one another. In another illustrative embodiment, the sensors 3036, control modules 3038, and the display 3040 are operatively connected to one another through a network 3042.

[0040] The network 3042 facilitates communication between the various modules 3038, sensors 3036, displays 3040, and/or other equipment operatively connected to the network 3042. In one illustrative embodiment, the network 3042 comprises a CAN network on a person support apparatus 3014. In another illustrative embodiment, the network 3042 is part of the signaling and communication system 3012. In some embodiments, the network 3042 comprises a Serial Peripheral Interface (SPI) network. It should be appreciated that the network 3042 can be other types of networks or communication protocols that can facilitate communication between two or more devices. It should also be appreciated that the module 3038 can be configured to connect to the network 3042 wirelessly, if desired. In one illustrative embodiment, the control module 3038 negotiates with the network 3042 to be a network node. According to some embodiments contemplated by this disclosure, the control modules 3038 can be located at or on any node on the network 3042 and/or distributed across multiple nodes on the network 3042.

[0041] In the illustrative example, the sensors 3036 are operatively connected to the control modules 3038 and include sensors that contact the person (contact sensors 3044) and/or sensors that do not contact the person (contact-less sensors 3046) as shown in FIG. 5. In one illustrative embodiment, the contact sensors 3044 contact a person's tissue to measure the desired parameter. In another illustrative embodiment, the contact-less sensors 3046 are integrated into the person support surface 3026. It should be appreciated that the contact-less sensors 3046 can be integrated into the portion of the ticking C1 contacting the person, if desired. In some embodiments, the contact-less sensors 3046 are coupled to at least one of the upper frame 3018, the supports 3020, and/or the lower frame 3016. It should be appreciated that the contact-less sensors 3046 can be coupled to the casters 3024 and/or engaged by the casters 3024, if desired.

[0042] The sensors 3036 are configured to sense a variety of parameters, including, but not limited to, for example, a person's physiological information, a position of a person on the person support apparatus 3014 and/or person support surface 3026, a pressure of the fluid inside the bladders 3028 in the person support surface 3026, or other various parameters. In one illustrative embodiment, the contact sensors 3044 include blood pressure sensors 3048 that are configured to sense the person's blood pressure; oxygen saturation level (SpO₂) sensors 3050 that are configured to sense the amount of hemoglobin binding sites in the person's bloodstream occupied by

oxygen; temperature sensors 3052 that are configured to sense the person's body temperature; heart rate sensors 3054 that are configured to sense the rate at which a person's heart contracts; and respiration rate sensors 3056 that are configured to sense the person's breathing rate as shown in FIG. 5. It should be appreciated that the SpO₂ sensors 3050 comprise a pulse oximeter device in some embodiments. It should be appreciated that the contact sensors 3044 are configured to measure other physiological and biochemical parameters in other embodiments.

[0043] In some embodiments, the contact-less sensors 3046 include one or more of the following: force sensors 3058 configured to sense the force profile and/or distribution of a person supported on a person support apparatus 3014; pressure sensors 3060 configured to measure the pressure in or among the bladders 3028; temperature sensors 3062 configured to sense the person's body temperature; heart rate sensors 3064 configured to sense the rate at which the person's heart contracts; respiration rate sensors 3066 configured to sense the person's breathing rate; and other sensors configured to sense information corresponding to the status of the person-support apparatus 3014, such as, for example, the angle of the head deck section HD with respect to the longitudinal axis X1 as shown in FIG. 5.

[0044] In some embodiments, the force sensors 3058 are load cells 3058 that couple the intermediate frame 3032 to the upper frame base 3034 proximate the corners of the upper frame 3018 and are configured to measure the weight of a person on the person support apparatus 3014. Alternatively or additionally, the force sensors 3058 comprise piezoelectric sensors and/or elongated sensor strips or arrays 3058 in some embodiments. In some embodiments, the pressure sensors 3060 are coupled between the bladders 3028 such that they allow communication between adjacent bladders 3028. In some embodiments, pressure sensors 3060 are situated within the bladders 3028 and measure the pressure within the bladder 3028.

[0045] In some embodiments, the heart rate sensors 3064 and respiration rate sensors 3066 are integrated into the surface 3026. In some embodiments contemplated herein, the heart rate sensors 3064 and respiration rate sensors 3066 are force sensors 3058 and/or pressure sensors 3060. It will be appreciated that the sensors 3036 are configured to sense various other physiological characteristics. In some embodiments, the heart rate sensors 3064 and respiration rate sensors 3066 are pressure-strip sensors disposed on the fluid bladders 3028 along an axis parallel to the lateral axis Y1 and/or along an axis parallel to the longitudinal axis X1.

[0046] The control modules 3038 can each be configured to perform different operations, if desired. According to this disclosure, a single control module 3038 can be configured to perform the multiple different operations if desired. Optionally, a single control module 3038 can be configured to perform operations independently or in conjunction with at least one other control module 3038. In one contemplated embodiment, one control module 3038, such as, a person position monitor module (not shown) (PPM), is configured to detect the position of a person on the person support apparatus 3014. Alternatively or additionally, a second control module 3038, such as a therapy control module (not shown), is configured to sense and/or modify the pressure within the fluid bladders 3028. Optionally, a third control module 3038, such as a physiological parameter monitor (not shown), is configured to detect a person's physiological information. In some

embodiments, a fourth control module **3038**, such as a wake up detector (not shown), is configured to detect when a person is regaining consciousness.

[0047] The control modules **3038** are implemented using software or hardware. In some embodiments, the control modules **3038** are implemented in software and are configured to perform one or more operations. In some embodiments, for example, the modules **3038** are configured to communicate via a memory mailbox where information from one module is sent to the memory address of a recipient module. In other embodiments, the software modules are configured to push information in a memory location, such as, a stack, that the control modules **3038** monitor or periodically check for information that the software modules subscribe to.

[0048] In contemplated embodiments, the control module **3038** is implemented using hardware. The control module **3038** includes a controller **3074** or processor **3074** and memory **3076** as shown in FIG. 5. The controller **3074** is provided as a single component or a collection of operatively coupled components; and can be comprised of digital circuitry, analog circuitry, or a hybrid combination of both of these types. When of a multi-component form, controller **3074** has one or more components remotely located relative to the others. The controller **3074** can include multiple processing units arranged to operate independently, in a pipeline processing arrangement, in a parallel processing arrangement, and/or such different arrangement as would occur to those skilled in the art.

[0049] In some embodiments, processor **3074** is a programmable microprocessing device of a solid-state, integrated circuit type that includes one or more processing units and memory. The controller **3074** can include one or more signal conditioners, modulators, demodulators, Arithmetic Logic Units (ALUs), Central Processing Units (CPUs), limiters, oscillators, control clocks, amplifiers, signal conditioners, filters, format converters, communication ports, clamps, delay devices, memory devices, and/or different circuitry or functional components as would occur to those skilled in the art to perform the desired communications. In some embodiments, the controller **3074** includes a computer network interface to communicate among various system components and/or components not included in the depicted system, as desired. The listed examples are not intended to be an exhaustive list of structures that are within the scope of controller **3074**, but are instead only a non-exhaustive list of such structures which can have substantial differences in the manner in which they are implemented and/or operate.

[0050] The controller **3074** is configured to receive input signals corresponding to signals from the sensors **3036** and/or output signals from other modules **3038** via the network **3042**. The information is stored in the memory **3076**, which is operatively coupled to the controller **3074** as shown in FIG. 5. It should be appreciated that the memory **3076** is integrated into the controller in some embodiments. The controller **3074** is configured to execute operating logic **3078** that defines various control, management, and/or regulation functions. This operating logic **3078** can be in the form of software, firmware, and/or dedicated hardware, such as, a series of programmed instructions, code, electronic files, or commands using general purpose or special purpose programming languages or programs that are executed on one or more general purpose or special purpose computers, processors,

other control circuitry, or networks; a hardwired state machine; and/or a different form as would occur to those skilled in the art.

[0051] In the illustrative embodiment, the controller **3074** includes operating logic **3078** in the form of procedure **3080**, for example, as shown in the flowchart of FIG. 6. Procedure **3080** includes operations/conditionals shown at blocks **3082**, **3084**, **3086**, and **3088**. Procedure **3080** is used to generate a condition score corresponding to the condition of a person, which is compared to a threshold in order to predict the onset of an adverse condition.

[0052] The thresholds are established in accordance with hospital specific standard protocols and/or are generic thresholds that can be modified as desired. In some embodiments, the preset thresholds that are set by standard hospital specific protocols, which are automatically selected based on information present in a person's electronic medical record (EMR), in patient profiles, and/or based on the condition score generated by the procedure **3080**. Alternatively or additionally, the thresholds are set by a caregiver through an interface (not shown) on the person-support apparatus **3014** by manually selecting the protocols or modifying the generic thresholds. In some contemplated embodiments, the thresholds are automatically modified based on information in the person's electronic medical record (EMR). It should be appreciated that the thresholds can be person specific and can be incorporated into the person's EMR. It should also be appreciated that the thresholds can be incorporated into a patient profile that can be used for multiple people with similar characteristics. In some embodiments, the thresholds are modified by a caregiver through the signaling and communication system **3012**.

[0053] Illustrative procedure **3080** begins with operation **3082** where, in one illustrative embodiment, the sensors **3036** post electronic data signals corresponding to at least one of an event and an amount on the network **3042**. In some embodiments, the sensors **3036** post electronic data signals to a memory mailbox or register (not shown) where the modules **3038** are implemented in software. In some embodiments, sensors **3036** post data signals substantially continuously and, in other embodiments, sensors **3036** post data signals at predetermined intervals. The data signals from sensors **3036** are representative of heart rate, respiration rate, temperature, blood pressure and/or SpO₂ as indicated at block **3082** of FIG. 6. Data signals corresponding to features of the person support apparatus **3014** are also posted to the network such as, for example, signals from force sensors **3044** of a patient position and/or movement monitoring system of apparatus **3014** and are used in a similar manner as signals from sensors **3036** in procedure **3080**.

[0054] In the conditional of block **3084**, the controller **3074** examines each of the data signals posted by the sensors **3036** on the network **3042** and determines if the associated module **3038** subscribes to the data. If the module **3038** does not subscribe to the data, then the algorithm returns to block **3082** and awaits more incoming data.

[0055] If at block **3084** it is determined that module **3038** subscribes to the data, the algorithm proceeds to the operation of block **3086** and the data is input into an algorithm that is used to predict an adverse event or condition. In some embodiments, the data signals can be used to select one or more standard hospital specific protocols, which, in some instances, have predetermined thresholds associated therewith. Alternatively or additionally, the data signals can be

input into an algorithm that is used to select the hospital specific protocols and/or to set the predetermined thresholds associated with the protocols.

[0056] In the operation of block **3088**, the controller **3074** executes the algorithm to generate a condition score corresponding to the condition of the person and/or to generate a graphic representative of the condition of the person. In one embodiment, the algorithm receives inputs from the contactless sensors **3046** corresponding to the heart rate, respiration rate, and temperature of a person, and inputs from the contact sensors **3044** corresponding to the blood pressure and SpO₂ of a person. It should be understood that all of the inputs can be from the contact sensors **3044** in other embodiments. The controller **3074** processes the data inputs in accordance with the algorithm to calculate the condition score and/or generate the graphic.

[0057] In some embodiments, the algorithm combines the inputs into a data point, which is used to calculate a condition score constituting a one-dimensional visualization space based on the distance of the data point in a multi-dimensional measurement space, whose coordinates are defined by values of the inputs, from a normal point. In other contemplated embodiments, the algorithm maps the inputs from an n-dimensional measurement space to an m-dimensional visualization space using a dimensionality reduction mapping technique, and displays the m-dimensional visualization space on the display **3040**. One example of such a system using this algorithm and technique is disclosed in U.S. Pat. No. 7,031,857 issued on Apr. 18, 2006 to Tarassenko et al., which is hereby incorporated by reference herein in its entirety. One condition score in accordance with the teachings of U.S. Pat. No. 7,031,857 is known as a Visensia® index that can be produced by the Visensia® system sold by OBS Medical, for example. The Visensia® index creates a score based on heart rate, respiration rate, blood pressure, temperature, and SpO₂ data.

[0058] Based on the foregoing, it will be understood that the Visensia® index is a condition score that is based on, or a function of, only a person's physiological data. According to this disclosure, some or all of the physiological data used to calculate the Visensia® index is obtained by one or more sensors included as part of the person support apparatus **3014**. This distinguishes over the known prior art. To the extent that some of the physiological data needed to calculate a condition score, such as the Visensia® index, is obtained by equipment and/or sensors that are not included as part of person support apparatus **3014**, such data is transmitted to controller **3074** in accordance with this disclosure for the purpose of calculating the condition score. For example, data is transmitted to controller **3074** from a person's EMR in some instances as suggested diagrammatically in FIG. 5. In other instances, person support apparatus **3014** is communicatively coupled to physiological monitoring equipment that is co-located with apparatus **3014** to obtain the needed data for calculating a condition score. In the preceding examples, controller **3074** automatically initiates the queries to obtain the needed data from the EMR or co-located equipment and/or picks up the needed data from network transmissions. Thus, controller **3074** automatically calculates the condition score without the need for any further actions on the part of caregivers or users. However, it is within the scope of this disclosure for some or all of the needed physiological data to be entered by a caregiver using a user interface of the apparatus **3014**.

[0059] In another contemplated embodiment, the condition score comprises a modified early warning score (MEWS). According to this disclosure, the data needed to calculate the MEWS is obtained from sensors included as part of person support apparatus **3014**, obtained via manual user inputs, obtained from separate monitoring equipment that communicates with controller **3074** of apparatus **3014**, and/or obtained from the person's EMR. The MEWS is a known score calculated based on the following table:

	Score						
	3	2	1	0	1	2	3
Systolic BP	<70	71-80	81-100	101-199	—	>200	—
Heart rate (BPM)	—	<40	41-50	51-100	101-110	111-129	>130
Respiratory rate (RPM)	—	<9	—	9-14	15-20	21-29	>30
Temperature (° C.)	—	<35	—	35.0-38.4	—	>38.5	—
AVPU	—	—	—	A	V	P	U

[0060] In the MEWS table, the various integers in the column headings are added together based on the various readings for the person of the data corresponding to the rows of the table. A score of 5 or greater indicates a likelihood of death. With regard to the systolic blood pressure, heart rate, respiratory rate, and temperature portions of the MEWS, those pieces of information are obtained using sensors **3036** of person support apparatus **3014** and/or using the other manners of obtaining a person's physiological data as discussed above. It is contemplated by this disclosure that the AVPU portion of the MEWS is obtained using information from the person support apparatus **3014** as discussed below.

[0061] The AVPU portion of the MEWS indicates whether a person is alert (A), responsive to voice (V), responsive to pain (P), or unresponsive (U). As discussed above, the person support apparatus **3014** in some embodiments comprises a hospital bed having a patient position monitoring system including sensors, such as load cells, piezoelectric sensors, and/or force sensitive resistors (FSR's) which sense a patient's position and/or movement. In accordance with this disclosure, the patient movement information is used by the controller to automatically assign an appropriate integer corresponding to the A portion or the U portion of the AVPU line of the MEWS depending upon the amount of movement of the patient. For example, if the patient has not moved for a threshold amount of time, such as fifteen minutes or an hour or some threshold greater than or less than these particular times, then the integer associated with the U portion of the AVPU line of the MEWS is assigned automatically by controller **3074**. If the patient has moved by a threshold amount within a particular time period, then the integer associated with the A portion of the AVPU line of the MEWS is assigned automatically by controller **3074**.

[0062] It is contemplated by this disclosure that the controller **3074** initiates a voice query to the person in some embodiments. If the person answers the voice query orally or by engaging a designated user input, such as pressing a particular button mentioned in the voice query, then the controller **3074** automatically assigns an appropriate integer corresponding to the V portion of the MEWS. The voice query is a pre-recorded message in some embodiments. The voice query is initiated by controller **3074** if the person has been

inactive for the threshold period of time. In other words, in some embodiments, the voice query is initiated only after the conditions for assigning the U portion of the MEWS has been satisfied. Thus, if the person responds properly to the voice query, the AVPU portion of the MEWS is assigned as V rather than U. Apparatus 3014, therefore, has speakers or similar such sound-producing devices through which the voice query is played and, in some instances, a microphone that picks up the person's oral response. Appropriate interactive voice recognition (IVR) software is provided in such embodiments.

[0063] With regard to determining whether to select the P portion of the AVPU line of the MEWS score, apparatus 3014 is operated to inflict some amount of discomfort to the patient and then monitors the person's response, such as an oral response or movement. For example, in some embodiments, apparatus 3014 includes an inflatable cuff or sleeve placed on a limb of the person and the controller 3074 controls inflation and deflation of the cuff or sleeve. If the patient movement information indicates sufficient patient movement by the patient in response to inflation of the cuff or sleeve, then the controller automatically assigns the appropriate integer corresponding to the P portion of the AVPU line of the MEWS. Alternatively or additionally, a microphone is used to determine if the patient expresses an audible pain or discomfort sound at which point the integer associated with the P portion of the AVPU line of the MEWS is assigned. The steps for determining whether to assign the P integer are performed only after the steps for determining whether to assign the U integer and/or the V integer in some embodiments. That is, operating the person apparatus 3014 so as to cause the patient some discomfort is only done as a last resort. In assigning the AVPU integer in the MEWS, it will be appreciated that it is the lowest pertinent integer that is assigned. Clearly, an alert person would also be responsive to voice for example.

[0064] The MEWS and Visensia® index discussed above are just a couple of examples of condition scores according to this disclosure. The teachings of this disclosure are intended to be broadly applicable to all types of condition scores.

[0065] Referring once again to FIG. 6, in the operation of block 3090, the controller 3074 compares the calculated condition score (referred to sometimes in FIG. 6 as an "index value" or simply an "index") with the predetermined thresholds to determine at least one of the likelihood that an adverse condition will occur, an amount of time before an adverse condition will occur, and/or how close the condition score is to the threshold.

[0066] In the conditional of block 3100, if the controller 3074 determines that the condition score is greater than the threshold, then, in one illustrative embodiment, a status update including the condition score is communicated to a caregiver through the signaling and communication system 3012 and/or is displayed on the display 3040 as indicated at block 3110. That is, if the condition score exceeds the threshold, then, in some embodiments, at least one of the condition score and an alert signal are communicated to a caregiver. In other embodiments, the alert condition may correspond to the condition score being less than, rather than greater than, a particular threshold. The term "greater than" is intended to cover one or both of a greater than situation and a greater than or equal to situation and the term "less than" is intended to cover one or both of a less than situation and a less than or equal to situation.

[0067] As alluded to above, in some embodiments, the condition score and/or alert signal are communicated to a

caregiver through the signaling and communication system 3012. Alternatively or additionally, the condition score and/or alert signal are displayed on the display 3040. In still other embodiments, the condition score and/or alert signal are communicated to the Visensia® Alert system sold by OBS Medical. In further embodiments, the condition score is communicated to and stored in the person's EMR.

[0068] The display 3040 is any suitable display such as a liquid crystal display, touch screen display, plasma screen, light emitting diode display, cathode ray tube display, or other conventional display. The display 3040 is operable to display multiple parameters thereon along with the condition score in some embodiments. In some contemplated embodiments, the display 3040 displays physiological and/or biochemical information sensed by contact sensors 3044 along with the condition score. Thus, it is within the scope of this disclosure for the display 3040 to display physiological and/or biochemical information on the display 3040 along with the condition score. In yet other embodiments, the display 3040 displays bed status information and/or graphics, for example, a head deck section HD angle or PPM armed indicator, on the display along with the condition score. In still other contemplated examples, the display 3040 displays bed status information and/or graphics along with patient condition graphics, such as, pie charts. Other information that is displayable on the display 3040 includes force profile information and/or graphics, person position information and/or graphics, weight, and other physiological information.

[0069] Referring now to FIGS. 7 and 8, the sensors 3036 are operatively coupled to the control modules 3038 and are configured to sense various parameters, including, but not limited to, for example, a person's physiological information, a position of a person on the person support apparatus 3014 and/or person support surface 3026, a pressure of the fluid inside the bladders 3028 in the person support surface 3026, or other various parameters. As mentioned above, the sensors 3036 can be sensors configured to contact the tissue of a person and/or sensors configured to not contact the tissue of a person. In some embodiments, the sensors 3036 are force sensors 3044 coupled to the upper frame 3018 and are configured to measure force on the upper frame 3018 as shown in FIGS. 4 and 7. In some embodiments, the sensors 3036 are force sensors 3044 that measure force on the upper frame 3018 and are positioned between the intermediate frame 3032 and the upper frame base 3034 so as to couple the intermediate frame 3032 and deck 3030 to the upper frame base 3034.

[0070] In some contemplated embodiments, the sensors 3036 are force sensors 3044 integrated into the person support surface 3026 and configured to measure changes in force on the person support surface 3026 as shown in FIG. 4. Alternatively or additionally, the force sensors 3044 are coupled to the supports 3020 and/or the lower frame 3016. Sensors 3044 integrated into the casters 3024 and/or engaged by the casters 3024 are also within the scope of this disclosure. In some embodiments, the force sensors 3044 are load cells that are coupled proximate the corners of the intermediate frame 3032. In other embodiments, the sensors 3044 are piezoelectric sensors and/or elongated sensor strips or arrays 3038. It will be appreciated that the force sensors 3044 comprising other force sensor types can be provided and positioned in other locations on the upper frame 3018 and/or within the person support surface 3026.

[0071] In some embodiments, the sensors 3036 are pressure sensors 3046 integrated into the person support surface

3026 and configured to measure the pressure in or among the fluid bladders 3028 in the person support surface 3026 as shown diagrammatically in FIG. 7. The pressure sensors 3046 are coupled between the bladders 3028 in some embodiments such that they can allow communication between adjacent bladders 3028. It should be appreciated that the pressure sensors can be situated within the bladders 3028 and/or otherwise positioned to measure the pressure within the bladder 3028. Pressure sensors 3046 coupled to bladders 3028 via pneumatic tubes, hoses, or other types of conduits are contemplated by this disclosure as well.

[0072] In some embodiments, the sensors 3036 are physiological sensors 3048 integrated into the person support surface 3026 and configured to measure various physiological parameters of a person supported on the person support surface 3026 as suggested in FIG. 7. Optionally, the physiological sensors 3048 can be coupled to the upper frame 3018, the supports 3020, and/or the lower frame 3016 in lieu of being coupled to the mattress 3046. As indicated above, the force sensor 3044 and/or pressure sensor 3046 are configured to sense physiological parameters in some embodiments. For example, one or more of the physiological sensors 3048 are used to sense the heart rate and/or respiration rate of a person supported on the person support surface 3026 in some embodiments. Alternatively or additionally, one or more of the physiological sensors 3048 are configured to sense the temperature of the person. In some embodiments, the physiological sensors 3048 are configured to sense the weight of the person on the person support surface 3026. In some embodiments, the physiological sensors 3048 are pressure-strip sensors disposed on the fluid bladders 3028 along an axis parallel to the lateral axis Y1 and/or along an axis parallel with the longitudinal axis X1.

[0073] In some embodiments, one or more of the sensors 3036 produces an analog data signal and is connected directly to the controller 3074. In other embodiments, one or more of the sensors 3036 produce a digital data signal, e.g., a serial digital data signal, and are connected to the network 3042, e.g., SPI network, to communicate with the controller 3074. The data signals can be stored in the memory 3076, which is operatively coupled with the controller 3074. As mentioned above, the memory 3076 is integrated into the controller 3074 in some embodiments.

[0074] In some embodiments, the controller 3074 executes operating logic 3062 that defines various control, management, and/or regulation functions as shown in FIG. 8. This operating logic 3062 can be in the form of software, firmware, and/or dedicated hardware, such as, a series of programmed instructions, code, electronic files, or commands using general purpose or special purpose programming languages or programs that can be executed on one or more general purpose or special purpose computers, processors, other control circuitry, or networks; a hardwired state machine; and/or a different form as would occur to those skilled in the art.

[0075] In one illustrative embodiment, the controller 3074 includes operating logic 3062 in the form of procedure 3064, for example, as shown in the flowchart of FIG. 8. Procedure 3064 includes operations/conditionals as indicated at blocks 3066, 3068, 3070, 3072 and 3074. Procedure 3064 is used to determine when a person is regaining consciousness by comparing the heart rate (HR), respiration rate (RR), and/or movement of the person to predetermined thresholds.

[0076] The thresholds are established in accordance with hospital specific standard protocols in some embodiments

and/or are generic thresholds that can be modified by caregivers or automatically in other embodiments. In some embodiments, the preset thresholds that are set by standard hospital specific protocols, which in some instances are automatically selected based on information present in a person's electronic medical record (EMR), in patient profiles, and/or based on condition scores/indexes. In other embodiments, the thresholds are set by a caregiver through an interface (not shown) on the person-support apparatus 3014 by manually selecting the protocols or modifying the generic thresholds. In yet another contemplated embodiment, the thresholds are automatically modified based on the person's EMR. It is within the scope of this disclosure for the thresholds to be person specific and possibly incorporated into the person's EMR. In some embodiments, the thresholds are incorporated into a patient profile that is used for multiple people with similar characteristics. In some contemplated embodiments, the thresholds are modified by a caregiver through the signaling and communication system 3012. Alternatively or additionally, the thresholds are modified or established by, for example, setting an initial threshold and acknowledging whether the person is asleep or waking up to teach the system what the appropriate thresholds are to the particular person.

[0077] Procedure 3064 begins with operation 3066 where, in some embodiments, the force sensors 3044 and the physiological sensors 3048 post, i.e., load or place, electronic data signals corresponding to at least one of an event and an amount on the network 3042. According to contemplated embodiments, at least one of the force sensors 3044 and the physiological sensors 3048 post electronic data signals on the network 3042 either directly or via other circuitry of the person support apparatus 3014. Alternatively or additionally, at least one of the force sensors 3044 and the physiological sensors 3048 post electronic data signals to a memory mailbox or register. As mentioned above, the force sensors 3044 and/or the physiological sensors 3048 post data signals continuously in some embodiment and/or at predetermined intervals in other embodiments.

[0078] In the conditional of block 3068, the control modules 3038 examine the data signals posted by the force sensors 3044 and the physiological sensors 3048 on the network 3042 and determine if the module 3038 subscribes to the data. If the module 3038 subscribes to the data then the data is input into the operating logic 3062 and algorithm 3064 proceeds to block 3070. If the module 3038 does not subscribe to the data, then the algorithm 3064 returns to block 3066 as shown in FIG. 8.

[0079] In the operation of block 3070, the controller 3074 compares the posted data with one or more predetermined thresholds to determine if and how much a person has moved with respect to the surface 3020 and/or whether the person's respiration rate and/or heart rate has increased or decreased.

[0080] In the conditional of block 3072, if any one or more of the thresholds are exceeded, the controller 3074 generates an alert signal as indicated in the operation of block 3077 and communicates the alert to a caregiver through the signaling and communication system 3012 that the person is about to regain consciousness. In some embodiments, the controller 3074 also communicates to the caregiver data regarding patient movement, such as a force profile, the heart rate, and/or the respiration rate and the amount that each has changed. In some embodiments, the controller 3074 communicates the alert signal to a display 3040 coupled to the person support apparatus 3014. In some embodiments, the controller

3074 communicates the alert signal wirelessly or through the signaling and communication system **3012** to one or more of a caregiver station, a mobile paging device, a cellular phone, a pendant, or remote display (not shown). It should be appreciated that the controller **3074** can also communicate the alert signal through an intercom system (not shown), if desired. In some contemplated embodiments, the controller **3074** activates a light (not shown) coupled to the person support apparatus **3014** and/or situated outside the hospital room to alert a caregiver that the patient is about to regain consciousness.

[0081] According to this disclosure, person support apparatus **3014** reports information regarding a person's sleep quality. Such information is displayed on display **3040** in some embodiments. Alternatively or additionally, the sleep quality information is transmitted to the person's EMR. Also alternatively or additionally, the sleep quality information is displayed on the screen of a remote computer device. Thus, the sleep quality information is communicated through system **3012** in some embodiments to one or more of a caregiver station, a mobile paging device, a cellular phone, a pendant, or remote display of the type mentioned above. The sleep quality information is determined by controller **3074** via analysis of information sensed by sensors **3036** included in the mattress or bed frame of apparatus **3014**.

[0082] Sleep quality is determined in a number of ways such as by analysis of one or more of the following: 1) restlessness as measured by a bed mounted accelerometer or by the load cells of a bed's patient position and/or movement monitoring system, 2) heart rate variability, 3) respiratory rate variability, and/or 4) electroencephalograph (EEG) readings. There are known techniques for determining whether a person is deep stage sleep (stages III and IV), which are regarded as the most restful stages of sleep, by monitoring one or more these parameters, particularly by monitoring parameters **2-4**. Other aspects of sleep quality that are contemplated by this disclosure for monitoring and/or displaying and/or reporting and/or storing in a person's EMR including the following: 1) time until sleep onset (e.g., time it takes from when a person is ready to sleep until the person is actually asleep), 2) the amount of times the person has awoken during a sleep cycle, 3) the amount of times the person exited the person support apparatus during the cycle, 4) the amount of movement or restlessness during the sleep cycle regardless of stage of sleep, 5) the amount of time in each stage of sleep (i.e., states I-IV) including the amount of time deep sleep (stages III and IV), and 6) the amount of sleep apnea occurrences.

[0083] The sleep quality information provides an indication about a person's comfort during their stay at a healthcare facility, for example. Some health and healing rates are tied to quality and amount of sleep. Thus, the sleep quality information informs caregivers about the sleep that patients are getting, which assists in determining the type of everyday treatment the patients should receive. Also, sleep quality information can potentially be helpful in clearing up any arguments or complaints that a patient may have with a caregiver or hospital administrator regarding the patient's inability to get any sleep because of noise in the halls, caregiver interruptions, and so forth. Details of a sleep quality monitoring, display and reporting system are shown and described in U.S. Patent Application Publication No. 2010/0099954 A1 which is assigned to Zeo, Inc. and which is hereby incorporated by reference herein. According to this disclosure, a system similar to or even substantially the same as that disclosed in the '954 publication is integrated into a hospital bed.

[0084] Any theory, mechanism of operation, proof, or finding stated herein is meant to further enhance understanding of principles of the present disclosure and is not intended to make the present disclosure in any way dependent upon such theory, mechanism of operation, illustrative embodiment, proof, or finding. It should be understood that while the use of the word preferable, preferably or preferred in the description above indicates that the feature so described can be more desirable, it nonetheless can not be necessary and embodiments lacking the same can be contemplated as within the scope of the disclosure, that scope being defined by the claims that follow.

[0085] In reading the claims it is intended that when words such as "a," "an," "at least one," "at least a portion" are used there is no intention to limit the claim to only one item unless specifically stated to the contrary in the claim. When the language "at least a portion" and/or "a portion" is used the item can include a portion and/or the entire item unless specifically stated to the contrary.

[0086] While embodiments of the disclosure have been illustrated and described in detail in the drawings and foregoing description, the same are to be considered as illustrative and not restrictive in character, it being understood that only the selected embodiments have been shown and described and that all changes, modifications and equivalents that come within the spirit of the disclosure as defined herein or by any of the following claims are desired to be protected.

1. A method of predicting when a person supported on a bed is going to wake from an unconscious state, the method comprising:

sensing a change in position, a heart rate, or a respiration rate of the person on the bed with at least one sensor that is other than an acoustic sensor and that is included as part of the bed;

determining if at least one of the change in position, the heart rate, and the respiration rate is beyond a predetermined threshold; and

posting a person status signal to a network, wherein the person status signal is indicative of a conscious state or an unconscious state of the person.

2. The method of claim 1, wherein the person status signal indicative of the conscious state of the person is posted to the network when the difference between the first position and the second position, the first heart rate and the second heart rate, or the first respiration rate and the second respiration rate is greater than the predetermined threshold.

3. The method of claim 1, wherein the person status signal indicative of the unconscious state of the person is loaded on the network when the difference between the first force and the second force, the first heart rate and the second heart rate, or the first respiration rate and the second respiration rate is less than the predetermined threshold.

4. The method of claim 1, wherein the predetermined threshold is based on the person's electronic medical record.

5. The method of claim 1, wherein the predetermined threshold is set based on a patient profile.

6. The method of claim 1, further comprising controlling at least one function of the bed as a function of the person status signal.

7. The method of claim 1, wherein the at least one sensor is integrated into a person contacting surface of a person support surface of the bed.

8. The method of claim 1, wherein the at least one sensor is integrated into a frame of the bed.

9. The method of claim 1, wherein the at least one sensor is integrated into a bladder of a person support surface of the bed.

10. The method of claim 1, wherein the at least one sensor comprises at least one force sensor.

11. The method of claim 10, wherein the at least one force sensor comprises a load cell.

12. The method of claim 1, wherein the at least one sensor comprises at least one elongated sensor strip.

13. The method of claim 1, wherein the at least one sensor comprises at least one piezoelectric sensor.

14. The method of claim 1, wherein the at least one sensor is integrated into at least one caster of the bed.

15. The method of claim 1, wherein the threshold is set by a caregiver using an interface of the bed.

16. The method of claim 1, further comprising transmitting sleep quality information from the bed.

17. The method of claim 16, wherein the sleep quality information is determined based on one or more of the following: restlessness as measured by change of position of the

person, heart rate variability, respiratory rate variability, or electroencephalograph (EEG) readings.

18. The method of claim 16, wherein the sleep quality information is based on one or more of the following: time until sleep onset, the amount of times the person has awoken during a sleep cycle, or the amount of times the person exited the bed during the sleep cycle.

19. The method of claim 1, wherein determining if at least one of the change in position, the heart rate, and the respiration rate is beyond a predetermined threshold comprises determining that two of the change in position, the heart rate, and the respiration rate are beyond respective predetermined thresholds.

20. The method of claim 1, wherein determining if at least one of the change in position, the heart rate, and the respiration rate is beyond a predetermined threshold comprises determining that all three of the change in position, the heart rate, and the respiration rate are beyond respective predetermined thresholds.

* * * * *

专利名称(译)	用于支持和监视人的状况的装置		
公开(公告)号	US20150216474A1	公开(公告)日	2015-08-06
申请号	US14/689588	申请日	2015-04-17
[标]申请(专利权)人(译)	希尔 - 罗姆服务股份有限公司		
申请(专利权)人(译)	HILL-ROM SERVICES , INC.		
当前申请(专利权)人(译)	HILL-ROM SERVICES , INC.		
[标]发明人	RILEY CARL W RECEVEUR TIMOTHY J RIBBLE DAVID L		
发明人	RILEY, CARL W. RECEVEUR, TIMOTHY J. RIBBLE, DAVID L.		
IPC分类号	A61B5/00 G08B21/06 A61B5/0476 G08B21/04 A61B5/0205 A61B5/11		
CPC分类号	A61B5/4809 A61B5/0205 A61B5/1118 A61B5/4815 A61B5/0476 A61B5/0816 A61B5/7282 A61B5/6891 G08B21/0453 G08B21/06 A61B5/02405 A61B5/1115 A61B5/02055 A61B5/1113 A61B5/1117 A61B5/1126 A61B5/6887 A61B5/6892 A61B5/024 A61G7/005		
优先权	61/243714 2009-09-18 US 61/243741 2009-09-18 US 61/243806 2009-09-18 US 61/243825 2009-09-18 US		
其他公开文献	US9549705		
外部链接	Espacenet USPTO		

摘要(译)

人监测系统可操作以预测人的不利状况的发作。系统接收与人支持设备的特征相对应的第一信息和与人的生理特征相对应的第二信息。系统根据第一和第二信息计算条件分数。在一些情况下，如果状况分数超过预定阈值，则系统警告护理人员。可选地或另外地，当人员支持设备上支持的人通过监视位置，心率和呼吸率的变化中的一个或多个来恢复意识时，人员监视系统警告护理人员。还公开了一种监视人的睡眠质量并向一个或多个相关方呈现关于睡眠质量的信息的人监测系统。

