



US010524705B2

(12) **United States Patent**
Bechtel et al.

(10) **Patent No.:** **US 10,524,705 B2**
(45) **Date of Patent:** ***Jan. 7, 2020**

(54) **TISSUE OXIMETRY PROBE WITH TISSUE MARKING FEATURE**

5/72 (2013.01); *A61B 5/7246* (2013.01); *A61B 5/7282* (2013.01); *A61B 5/74* (2013.01);
(Continued)

(71) Applicant: **ViOptix, Inc.**, Fremont, CA (US)

(58) **Field of Classification Search**
None
See application file for complete search history.

(72) Inventors: **Kate LeeAnn Bechtel**, Pleasant Hill, CA (US); **Joseph Anthony Heanue**, Oakland, CA (US); **Lester John Lloyd**, Orinda, CA (US)

(56) **References Cited**

(73) Assignee: **ViOptix, Inc.**, Newark, CA (US)

U.S. PATENT DOCUMENTS

(*) Notice: Subject to any disclaimer, the term of this patent is extended or adjusted under 35 U.S.C. 154(b) by 468 days.

4,223,680 A 9/1980 Jobsis
4,286,599 A 9/1981 Hahn et al.
(Continued)

This patent is subject to a terminal disclaimer.

FOREIGN PATENT DOCUMENTS

(21) Appl. No.: **15/214,355**

JP 5261088 10/1993
JP 10216115 A 8/1998
(Continued)

(22) Filed: **Jul. 19, 2016**

OTHER PUBLICATIONS

(65) **Prior Publication Data**
US 2016/0324453 A1 Nov. 10, 2016

Alexandrakis, et al., "Accuracy of the Diffusion Approximation in Determining the Optical Properties of a Two-Layer Turbid Medium," *Applied Optics*, vol. 37, No. 31, Nov. 1, 1998, pp. 7403-7409.

Related U.S. Application Data

(Continued)

(63) Continuation of application No. 13/887,213, filed on May 3, 2013, now Pat. No. 9,392,978.
(Continued)

Primary Examiner — Eric F Winakur
Assistant Examiner — Marjan Fardanesh
(74) *Attorney, Agent, or Firm* — Aka Chan LLP

(51) **Int. Cl.**
A61B 5/1455 (2006.01)
A61B 90/00 (2016.01)
(Continued)

(57) **ABSTRACT**

(52) **U.S. Cl.**
CPC *A61B 5/14551* (2013.01); *A61B 5/0059* (2013.01); *A61B 5/0075* (2013.01); *A61B 5/1455* (2013.01); *A61B 5/1459* (2013.01); *A61B 5/1495* (2013.01); *A61B 5/14546* (2013.01); *A61B 5/14552* (2013.01); *A61B*

An intraoperative tissue oximetry device includes a tissue marker that includes one or more pens or one or more similar ink sources, such that the tissue marker can mark tissue according to oxygen saturation measurements made by the tissue oximetry device, thereby visually delineating regions of potentially viable tissue from regions of potentially nonviable tissue.

20 Claims, 11 Drawing Sheets

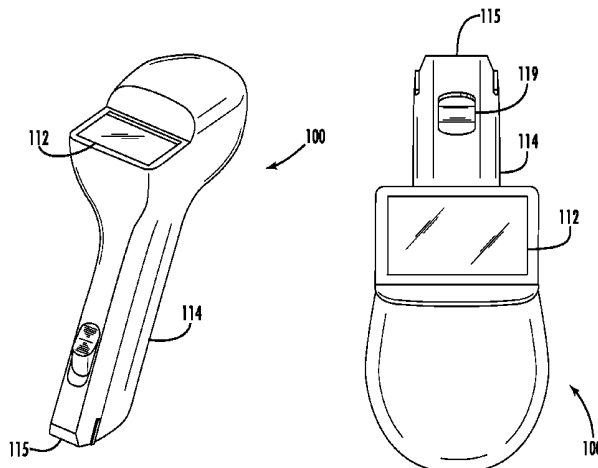

Related U.S. Application Data

- (60) Provisional application No. 61/642,395, filed on May 3, 2012, provisional application No. 61/642,393, filed on May 3, 2012, provisional application No. 61/642,389, filed on May 3, 2012, provisional application No. 61/642,399, filed on May 3, 2012, provisional application No. 61/682,146, filed on Aug. 10, 2012.

(51) Int. Cl.

A61B 5/1495 (2006.01)

A61B 5/00 (2006.01)

A61M 35/00 (2006.01)

A61B 5/145 (2006.01)

A61B 90/11 (2016.01)

A61B 5/1459 (2006.01)

A61B 90/30 (2016.01)

(52) U.S. Cl.

CPC *A61B 5/742* (2013.01); *A61B 5/7405* (2013.01); *A61B 5/7475* (2013.01); *A61B 90/11* (2016.02); *A61B 90/39* (2016.02); *A61M 35/003* (2013.01); *A61B 2090/065* (2016.02); *A61B 2090/306* (2016.02); *A61B 2090/395* (2016.02); *A61B 2560/0431* (2013.01); *A61B 2560/0475* (2013.01); *A61B 2562/0271* (2013.01); *A61B 2562/166* (2013.01)

(56)

References Cited

U.S. PATENT DOCUMENTS

5,088,493	A	2/1992	Giannini et al.
5,218,962	A	6/1993	Mannheimer et al.
5,517,301	A	5/1996	Dave
5,517,987	A	5/1996	Tsuchiya
5,690,113	A	11/1997	Sliwa et al.
6,056,692	A	5/2000	Schwartz
6,070,093	A	5/2000	Oosta et al.
6,078,833	A	6/2000	Hueber
6,197,034	B1	3/2001	Gvozdic et al.
6,285,904	B1	9/2001	Weber et al.
6,453,183	B1	9/2002	Walker
6,516,209	B2	2/2003	Cheng et al.
6,549,284	B1	4/2003	Boas et al.
6,587,701	B1	7/2003	Stranc et al.
6,587,703	B2	7/2003	Cheng et al.
6,597,931	B1	7/2003	Cheng et al.
6,708,048	B1	3/2004	Chance
6,735,458	B2	5/2004	Cheng et al.
6,766,188	B2	7/2004	Soller
6,839,580	B2	1/2005	Zonios et al.
7,247,142	B1	7/2007	Elmandjra et al.
7,254,427	B2	8/2007	Cho et al.
7,344,587	B2	3/2008	Kahn et al.
D567,949	S	4/2008	Lash et al.
7,355,688	B2	4/2008	Lash
D568,479	S	5/2008	Mao et al.
7,657,293	B2	2/2010	Lash et al.
8,798,700	B1	8/2014	Heaton et al.
2002/0019587	A1	2/2002	Cheng et al.
2002/0179094	A1	12/2002	Perlow
2004/0111016	A1	6/2004	Casscells et al.
2004/0260161	A1	12/2004	Melker
2005/0177069	A1	8/2005	Takizawa et al.
2005/0250998	A1	11/2005	Huiku

2005/0277818	A1	12/2005	Myers
2006/0129037	A1	6/2006	Kaufman et al.
2007/0149886	A1	6/2007	Kohls
2007/0225605	A1	9/2007	Swanbom
2008/0015422	A1	1/2008	Wessel
2008/0015424	A1	1/2008	Bernreuter
2008/0139908	A1	6/2008	Kurth
2008/0181715	A1	7/2008	Cohen
2008/0319290	A1	12/2008	Mao et al.
2009/0234209	A1	9/2009	Lash et al.
2009/0275805	A1	11/2009	Lane et al.
2010/0010486	A1	1/2010	Mehta et al.
2011/0028814	A1	2/2011	Petersen et al.
2011/0046458	A1	2/2011	Pinedo et al.
2011/0205535	A1	8/2011	Soller et al.
2011/0224518	A1	9/2011	Tindi et al.
2011/0237911	A1	9/2011	Lamego et al.

FOREIGN PATENT DOCUMENTS

JP	11244268	A	12/1999
JP	2006109964		4/2006
KR	1020000075056		12/2000
KR	1020090016744		2/2009
WO	2011008382		1/2011

OTHER PUBLICATIONS

Cen, et al., "Optimization of Inverse Algorithm for Estimating the Optical Properties of Biological Materials Using Spatially-Resolved Diffuse Reflectance," *Inverse Problems in Science and Engineering*, vol. 18, No. 6, Sep. 2010, pp. 853-872.

Dam, et al., "Determination of Tissue Optical Properties from Diffuse Reflectance Profiles by Multivariate Calibration," *Applied Optics*, vol. 37, No. 4, Feb. 1, 1998, pp. 772-778.

Farrell, et al., "Influence of Layered Tissue Architecture on Estimates of Tissue Optical Properties Obtained from Spatially Resolved Diffuse Reflectometry," *Applied Optics*, vol. 37, No. 10, Apr. 1, 1998, pp. 1958-1972.

Fawzi, et al., "Determination of the Optical Properties of a Two-Layer Tissue Model by Detecting Photons Migrating at Progressively Increasing Depths," *Applied Optics*, vol. 42, No. 31, Nov. 1, 2003, pp. 6398-6411.

Kienle, et al., "Spatially Resolved Absolute Diffuse Reflectance Measurements for Noninvasive Determination of the Optical Scattering and Absorption Coefficients of Biological Tissue," *Applied Optics*, vol. 35, No. 13, May 1, 1996, pp. 2304-2314.

Nichols, et al., "Design and Testing of a White-Light, Steady-State Diffuse Reflectance Spectrometer for Determination of Optical Properties of Highly Scattering Systems," *Applied Optics*, vol. 36, No. 1, Jan. 1, 1997, pp. 93-104.

Seo, et al., "Perturbation and Differential Monte Carlo Methods for Measurement of Optical Properties in a Layered Epithelial Tissue Model," *Journal of Biomedical Optics*, vol. 12(1), 014030, Jan./Feb. 2007, pp. 1-15.

Tseng, et al., "In Vivo Determination of Skin Near-Infrared Optical Properties Using Diffuse Optical Spectroscopy," *Journal of Biomedical Optics*, vol. 13(1), 014016, Jan./Feb. 2008, pp. 1-7.

Tseng, et al., "Analysis of a Diffusion-Model-Based Approach for Efficient Quantification of Superficial Tissue Properties," *Optics Letters*, vol. 35, No. 22, Nov. 15, 2010, pp. 3739-3741.

Mittnacht, et al., "Methylene Blue Administration is Associated with Decreased Cerebral Oximetry Values," *Anesthesia & Analgesia*, Aug. 2008, vol. 105, No. 2, pp. 549-550.

Hueber, Dennis et al., "New Optical Probe Designs for Absolute (Self-Calibrating) NIR Tissue Hemoglobin Measurements," in *Proceedings of Optical Tomography and Spectroscopy of Tissue III*, vol. 3597, 618-631(Jan. 1999).

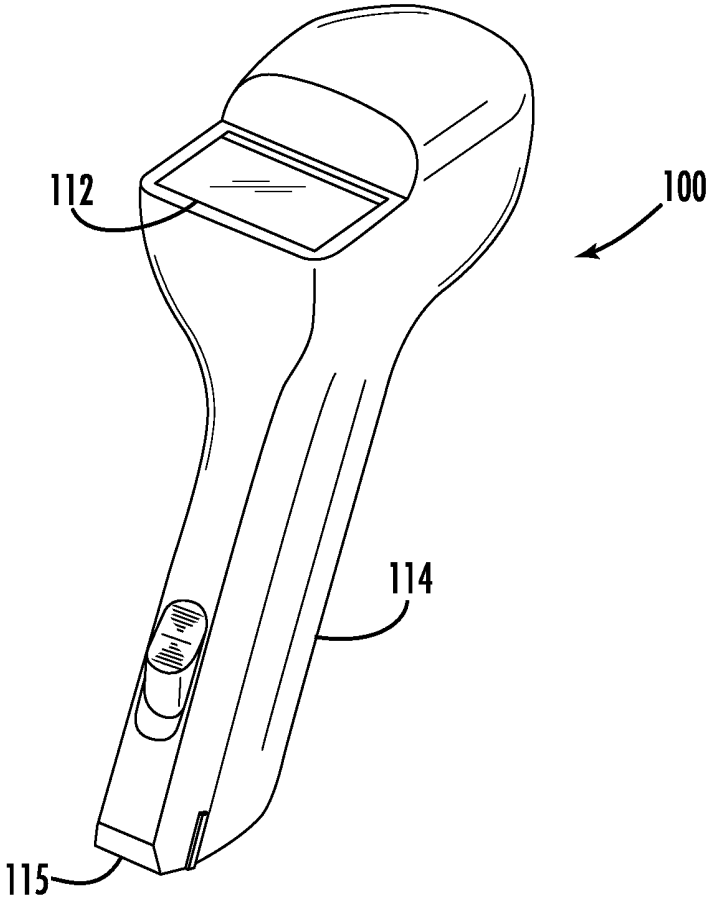

FIG. 1A

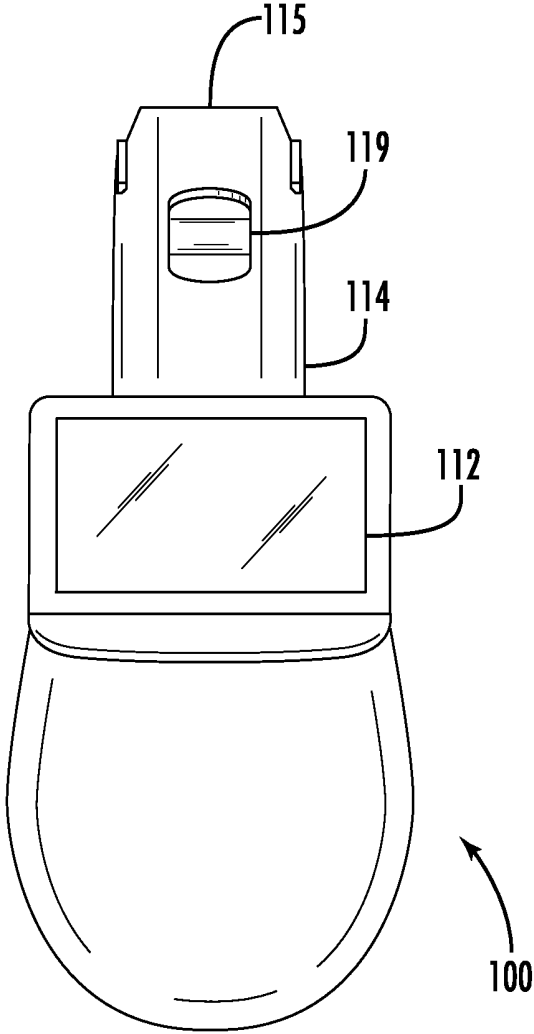

FIG. 1B

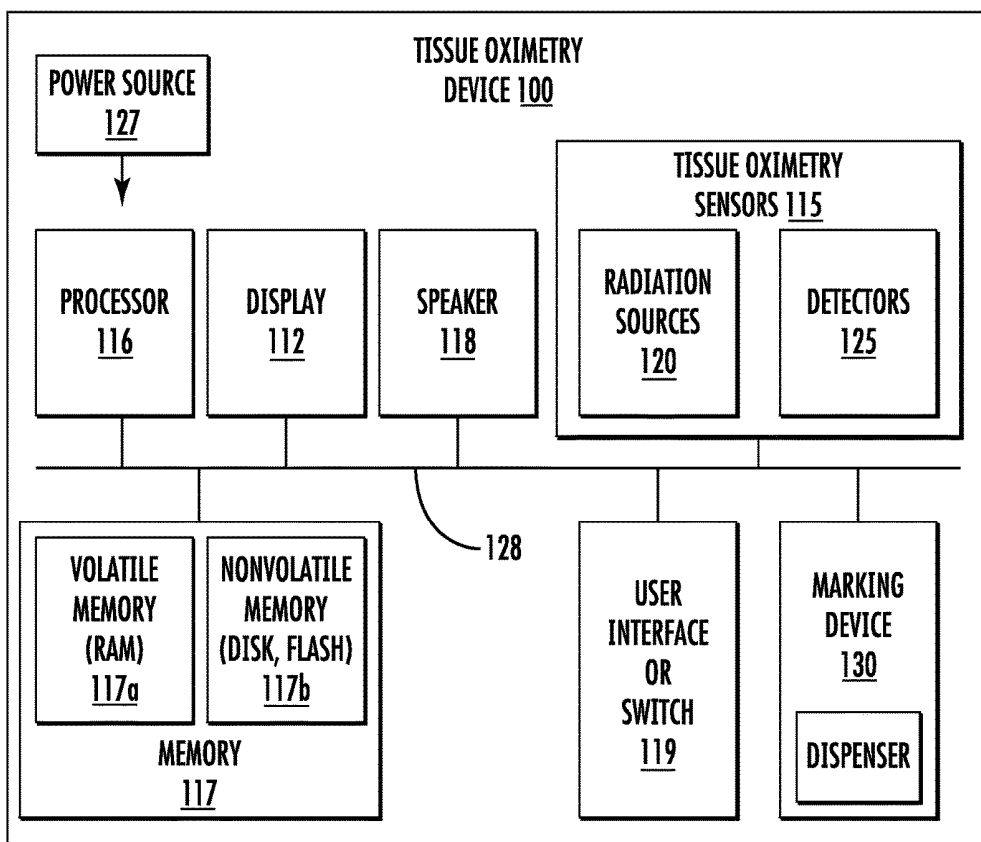

FIG. 1C

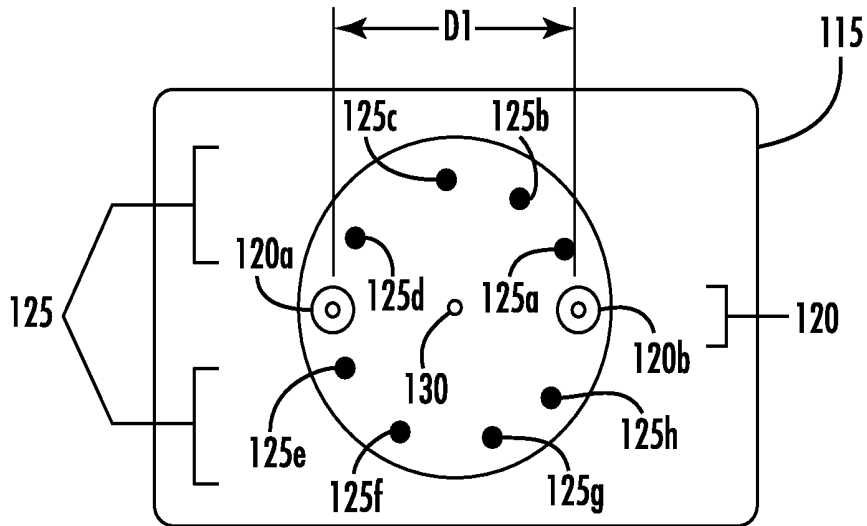

FIG. 2A

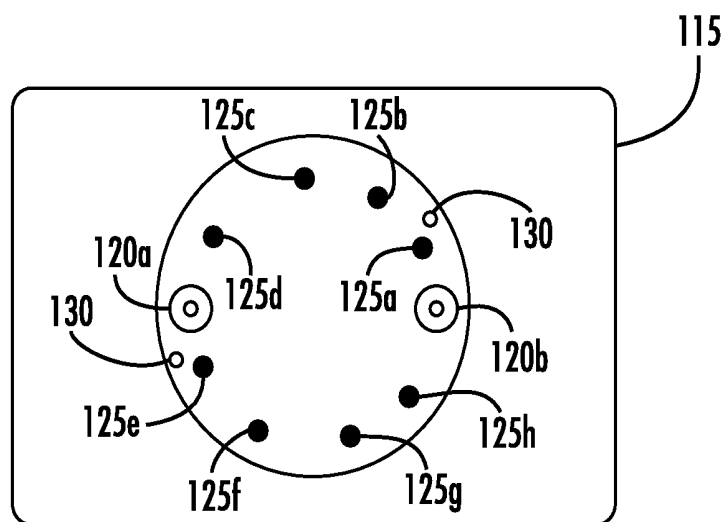

FIG. 2B

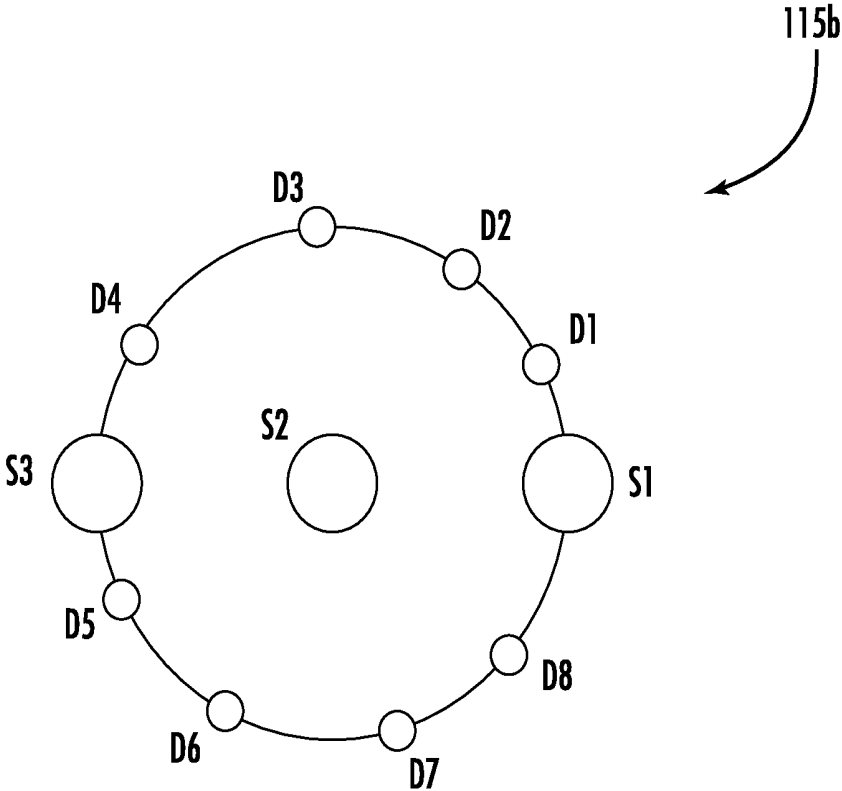
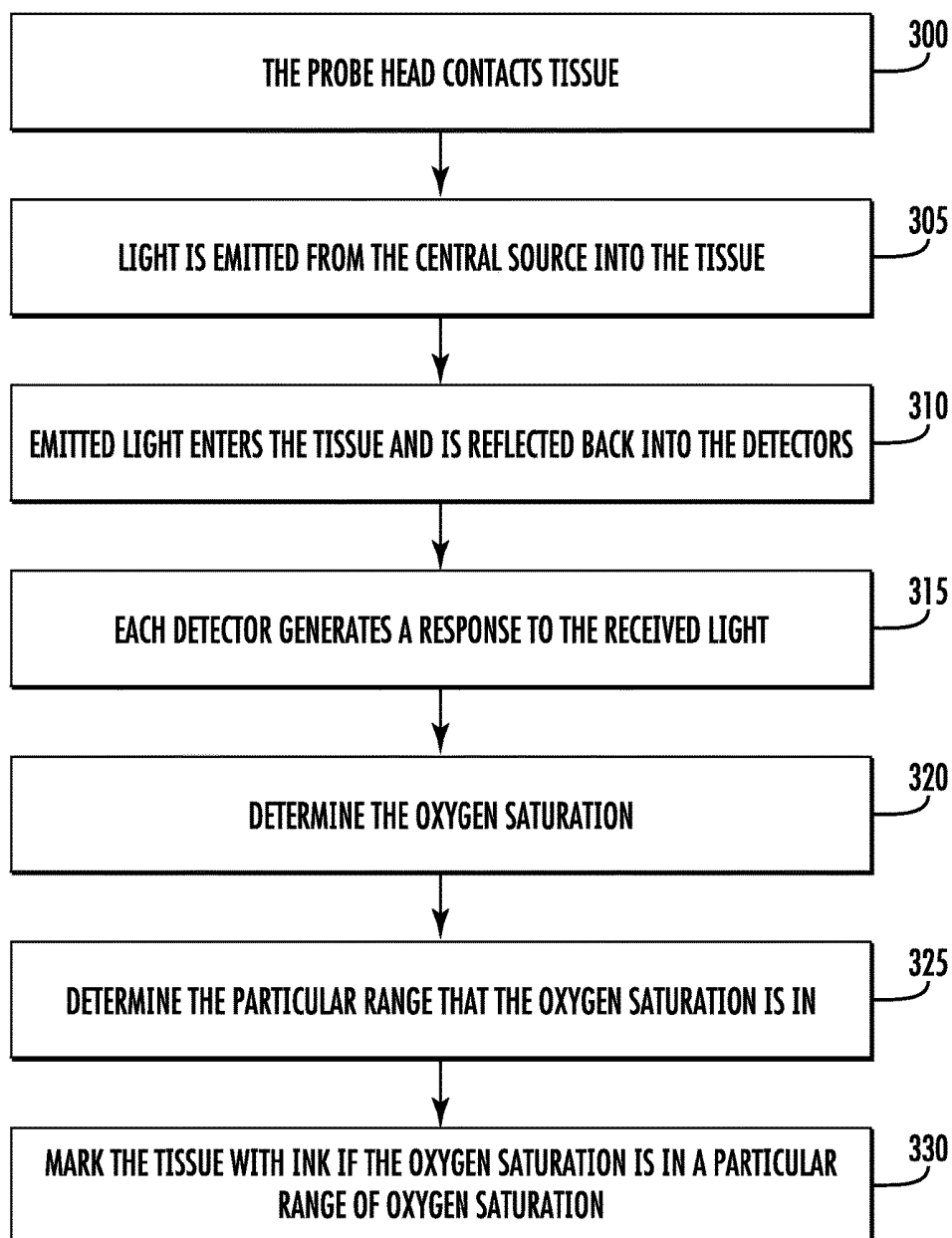

FIG. 2C

**FIG. 3**

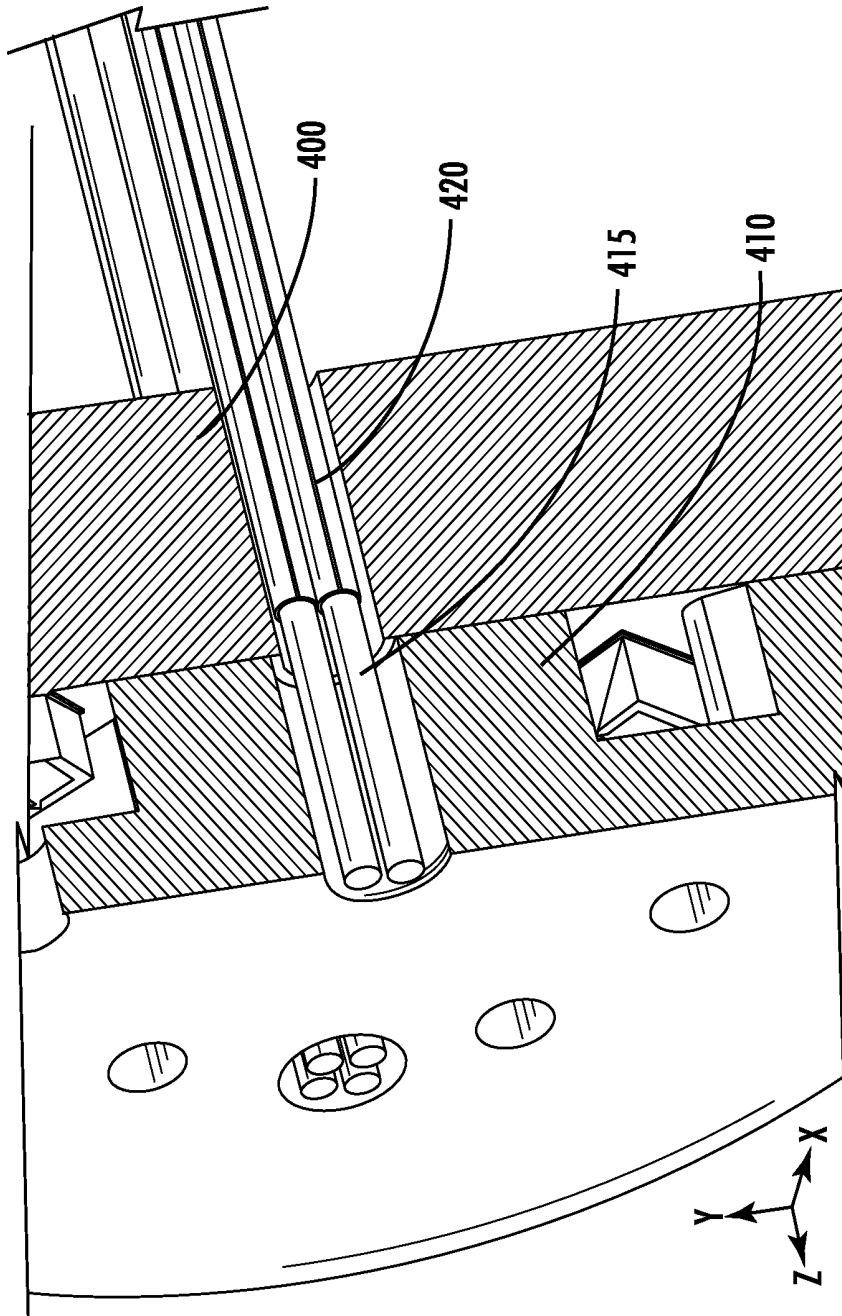

FIG. 4

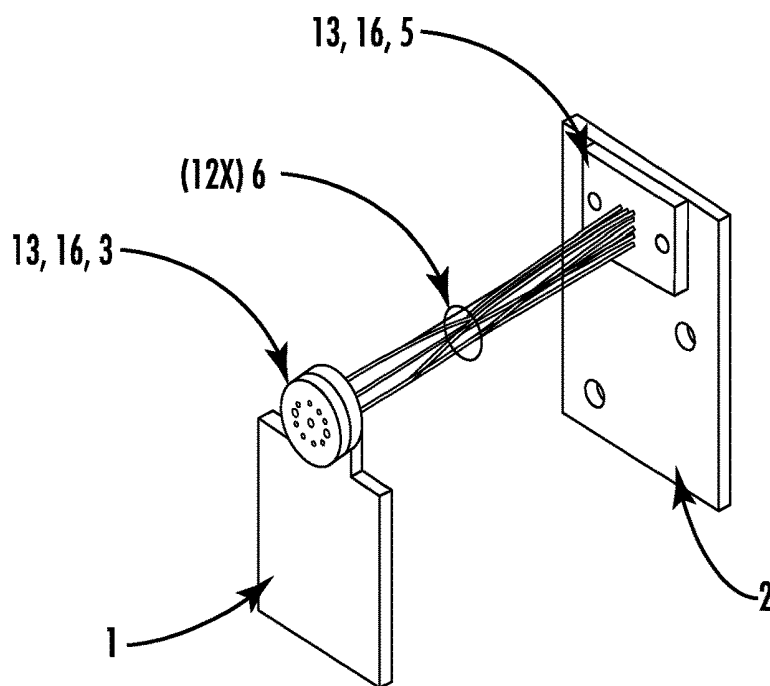

FIG. 5

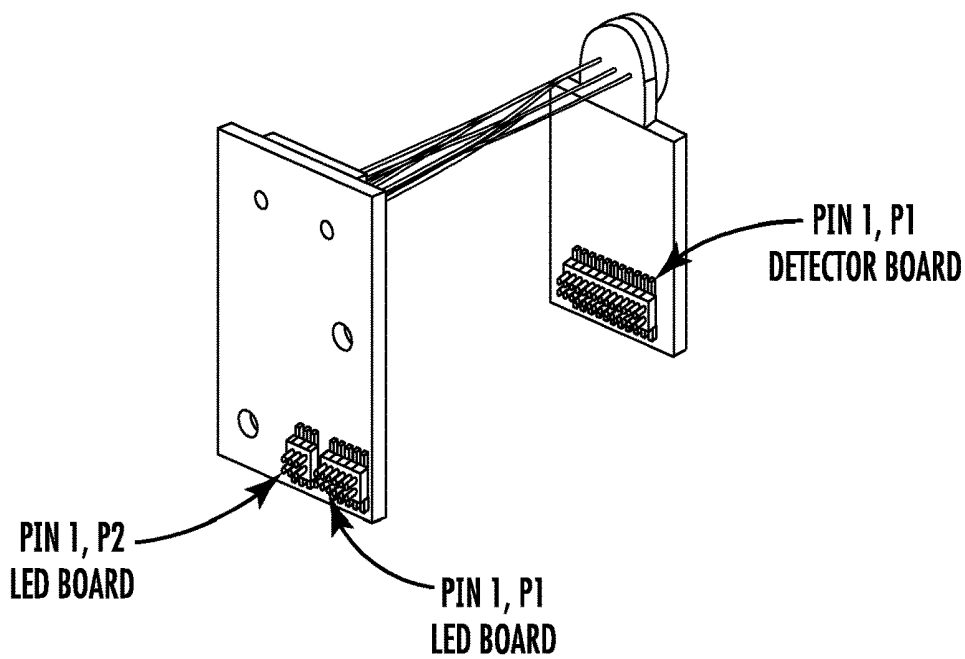
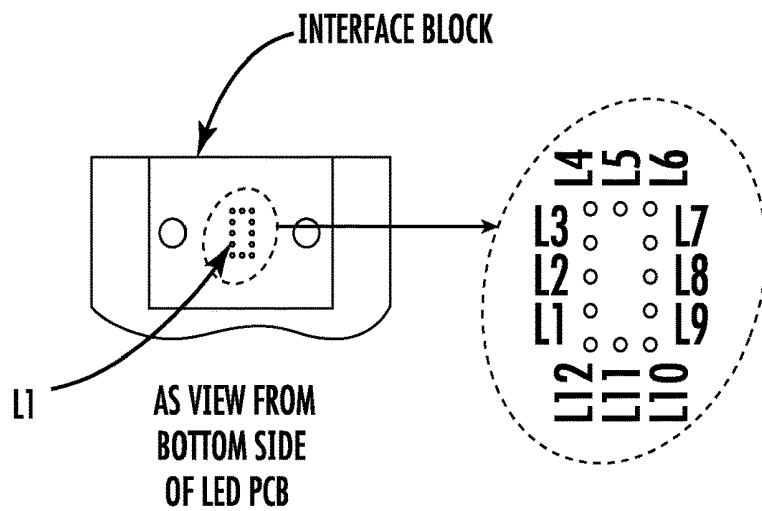
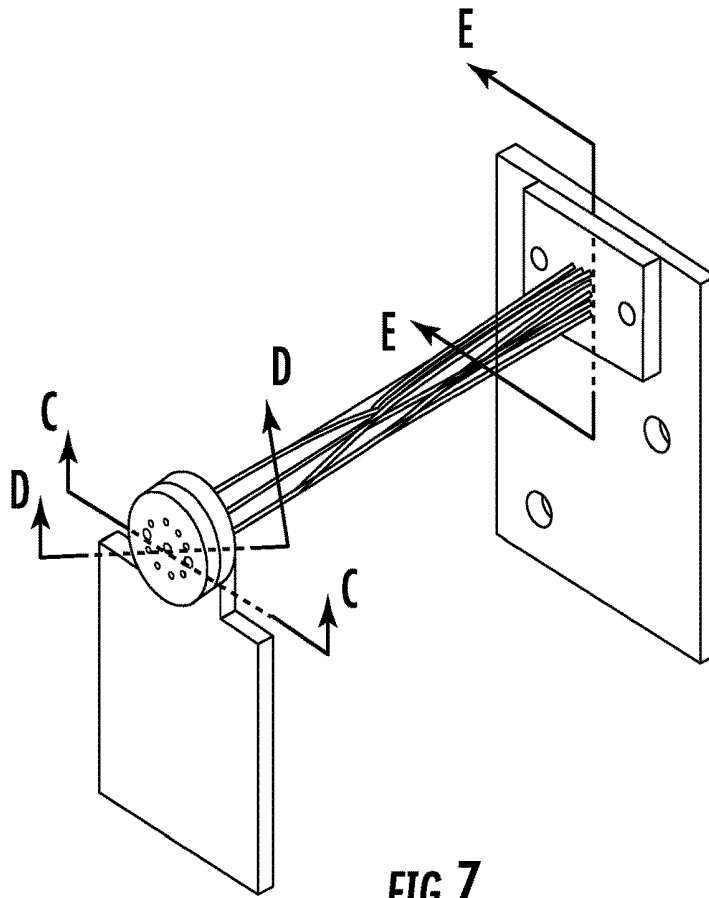

FIG. 6





WINDOW LOCATION

FIG. 9

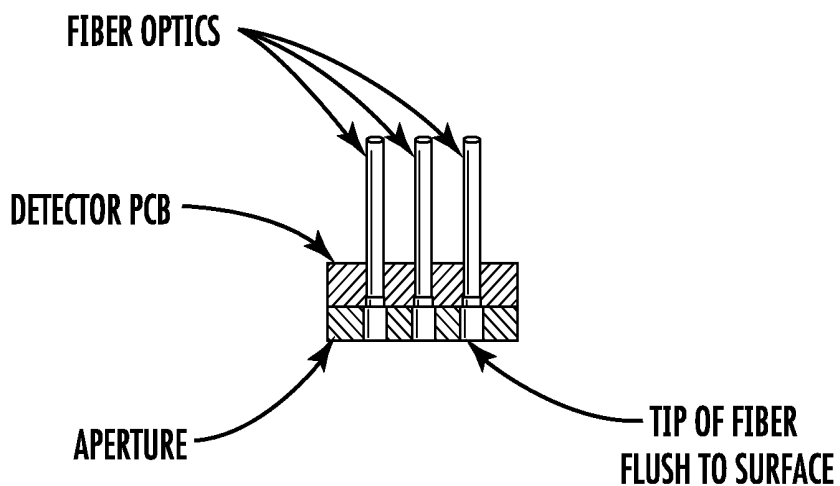

FIG. 10

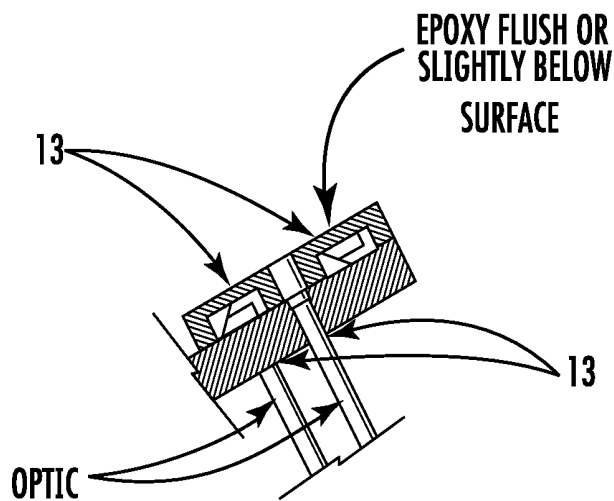

FIG. 11

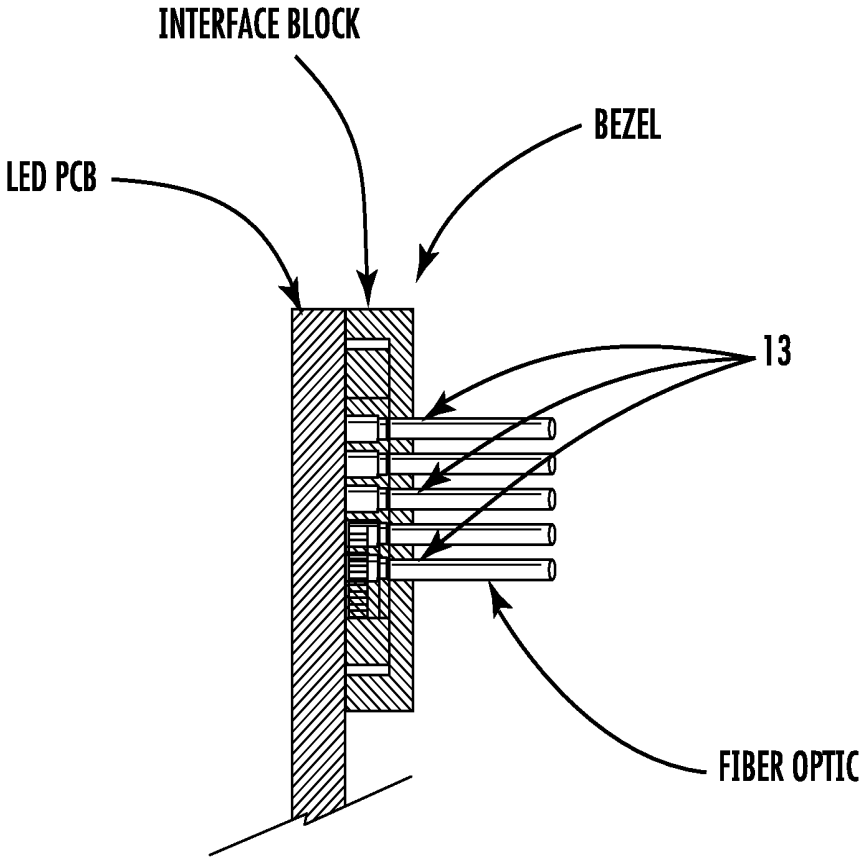

FIG. 12

TISSUE OXIMETRY PROBE WITH TISSUE MARKING FEATURE

This patent application is a continuation of U.S. patent application Ser. No. 13/887,213, filed May 3, 2015, issued as U.S. Pat. No. 9,392,978 on Jul. 19, 2016, which claims the benefit of U.S. patent applications 61/642,389, 61/642,393, 61/642,395, and 61/642,399, filed May 3, 2012, and 61/682,146, filed Aug. 10, 2012. These applications are incorporated by reference along with all other references cited in this application.

BACKGROUND OF THE INVENTION

The present invention relates generally to optical systems that monitor oxygen levels in tissue. More specifically, the present invention relates to an optical probe that includes light sources, detectors, and a marking apparatus for marking local tissue regions that are probed by the optical probe.

Oximeters are medical devices used to measure oxygen saturation of tissue in humans and living things for various purposes. For example, oximeters are used for medical and diagnostic purposes in hospitals and other medical facilities (e.g., surgery, patient monitoring, or ambulance or other mobile monitoring, such as for hypoxia); sports and athletics purposes at a sports arena (e.g., professional athlete monitoring); personal or at-home monitoring of individuals (e.g., general health monitoring, or personal training, such as for a marathon); and veterinary purposes (e.g., animal monitoring).

In particular, assessing a patient's oxygenation state is important as it is an indicator of the state of the patient's health. Thus, oximeters are often used in clinical settings, such as during surgery and recovery, where it may be suspected that the patient's tissue oxygenation state is unstable. For example, in reconstruction surgeries, it is desirable to distinguish between tissue that is viable and non-viable to save as much viable tissue as possible. Via the use of oximeters, physicians can attempt to distinguish between viable and non-viable tissue. However, physicians typically have to remember a map of viable tissue and non-viable tissue, which may slow down medical procedures.

Pulse oximeters and tissue oximeters are two types of oximeters that operate on different principles. A pulse oximeter requires a pulse in order to function. A pulse oximeter typically measures the absorbance of light due to pulsing arterial blood. In contrast, a tissue oximeter does not require a pulse in order to function, and can be used to make oxygen saturation measurements of a tissue flap that has been disconnected from a blood supply.

Human tissue, as an example, includes a variety of molecules that can interact with light via scattering or absorption (e.g., via light-absorbing chromophores). Such chromophores include oxygenated and deoxygenated hemoglobins, melanin, water, lipid, and cytochrome. Oxygenated and deoxygenated hemoglobins are the most dominant chromophores in the spectrum range of 600 nanometers to 900 nanometers. Light absorption differs significantly for oxygenated and deoxygenated hemoglobins at certain wavelengths of light. Tissue oximeters can measure oxygen levels in human tissue by exploiting these light-absorption differences.

Despite the success of existing oximeters, there is a continuing desire to improve oximeters by, for example, improving measurement accuracy; reducing measurement

time; lowering cost; reducing size, weight, or form factor; reducing power consumption; and for other reasons, and any combination of these.

Therefore, there is a need for oximeters that have improved form factors and that relieve physicians and medical personal of having to remember of map of tissue scanned by an oximeter.

BRIEF SUMMARY OF THE INVENTION

An intraoperative tissue oximetry device includes a pen or pens or similar ink source (or sources) such that tissue can be marked according to oxygenation measurements made by the tissue oximetry device, thereby visually delineating regions of potentially viable tissue from regions of potentially nonviable tissue.

According to an embodiment, the device is a handheld, self-contained, oximeter device. The oximeter probe is contained within a single housing including all the components, so that it is self-contained. No external connections via wires or wireless connectivity are needed. The probe has a compact size and is relatively light weight so that it can be held easily by a person's hand. The probe can include a handle for a person's hand to grip, or fingers to grip.

The probe includes a plurality of light sources configured to generate and emit light into a portion of an extended tissue region, and a plurality of detectors having a circular arrangement and configured to detect the light subsequent to reflection from the portion and generate reflectance data based on detection of the light. The handheld, self-contained, oximeter further includes a processor configured to determine the oxygen saturation of the portion based on the reflectance data, and includes a tissue marker. The tissue marker includes a dispenser that is located at substantially a center of a circle of the circular arrangement where the dispenser is configured to deposit ink onto the portion to indicate that the probe has probed the portion.

According to a specific embodiment, the dispenser is configured to deposit ink based on one or more ranges of the oxygen saturation. The processor may be configured to determine whether the oxygen saturation is in the one or more ranges and control the dispenser to deposit the ink based on the one or more ranges that the oxygen saturation is in.

According to a specific embodiment, the dispenser is configured to deposit a plurality of colors of ink; the processor is configured to control the tissue marker to deposit the colors of ink based on ranges of the oxygen saturation; and the ranges of the oxygen saturation are respectively associated with the colors of the ink. The processor may be configured to control the tissue marker to deposit the ink onto the portion, or alternatively, a user selection device, such as a switch, is configured to be activated by a user to control the tissue marker to deposit the ink.

According to another embodiment, a handheld, self-contained, oximeter includes a probe that in-turn includes: (i) a plurality of light sources configured to generate and emit light into a portion of an extended tissue region, and (ii) a plurality of detectors that has a circular arrangement and is configured to detect the light subsequent to reflection from the portion and generate reflectance data based on detection of the light. The handheld, self-contained, oximeter further includes a processor configured to determine oxygen saturation of the portion based on the reflectance data. The handheld, self-contained, oximeter further includes a tissue marker having a plurality of dispensers. The dispensers are

located outside of a circle of the circular arrangement and are configured to deposit ink onto the portion to indicate that the portion has been probed by the probe.

According to one embodiment, a method of operation of a handheld, self-contained oximeter includes emitting light into tissue, detecting the light subsequent to reflection of the light from the tissue, and generating reflectance data based on detecting the light. The method further includes determining an oxygen saturation of the tissue based on the reflectance data, and determining a range of oxygen saturation from a plurality of ranges of oxygen saturation in which the oxygen saturation lies. The method includes marking the tissue with ink based on the range that the oxygen saturation is in.

Oximeter embodiments of the present invention are capable of accurately measuring oxygenation saturation of tissue and marking regions of the tissue to indicate their viability or nonviability. Relatively quickly and easily determining viability from the markings is useful for a plastic surgeon, for example, where in intraoperative situations the plastic surgeon must quickly make determinations to distinguish between tissue that can be used for reconstruction and tissue that should be removed.

With the incorporation of the tissue marker, the tissue oximetry device may be used to fully examine multiple regions of tissue for viability prior to the creation of further surgical incisions or the removal or reconstruction of tissue. The tissue marker of the present invention allows for relatively precisely marking regions of tissue based on their oxygen saturation readings thus alleviating physicians from having to recall exactly which tissue may be considered viable based on oxygenation measurements once the physician has set aside the tissue oximetry device or has moved the tissue oximetry device to other tissue regions.

In an implementation, an oximeter probe is contained within a single housing. The oximeter probe includes: a number of light or radiation sources, positioned on a probe face of the housing, configured to generate and emit light or radiation into a portion of an extended tissue region; a number of detectors, positioned on the probe face, wherein the detectors are positioned in a circular arrangement and configured to detect the light subsequent to reflection from the portion; a processor, connected to the light sources and detectors, configured to process reflectance data received from the detectors and determine oxygen saturation of the portion based on the reflectance data; a battery power source, contained within the housing and connected to the light sources, detectors, and processor; and a tissue marking component having a dispenser or inking tip or head, connected to the probe face, where the dispenser is located within the circular arrangement (e.g., inside the circle) and is configured to deposit ink onto the portion, thereby indicating that the portion has been evaluated by the probe.

In another implementation, a method of operating an oximeter probe includes: emitting light into tissue from radiation sources positioned on a probe face of the oximeter probe housing; detecting the light subsequent to reflection of the light from the tissue using from detectors sources positioned on a probe face of an oximeter probe housing; generating reflectance data based on detecting the light by way of a processor contained with the oximeter probe housing; using the processor (e.g., without needing to use an external processor), determining an oxygen saturation of the tissue based on the reflectance data; using the processor, determining a range of oxygen saturation from a plurality of ranges of oxygen saturation in which the oxygen saturation lies; and marking the tissue with ink (or other fluid) based on

the range in which the oxygen saturation is in using ink (or other fluid) stored in a reservoir contained within the oximeter probe housing and a inking tip positioned on the probe face.

Other objects, features, and advantages of the present invention will become apparent upon consideration of the following detailed description and the accompanying drawings, in which like reference designations represent like features throughout the figures.

BRIEF DESCRIPTION OF THE DRAWINGS

FIGS. 1A and 1B show a simplified perspective view and a top view, respectively, of a tissue oximetry device according to one embodiment.

FIG. 1C shows a block diagram of the tissue oximetry device.

FIG. 2A shows a simplified end view of a tissue oximetry probe of the tissue oximetry device according to one embodiment where the ink dispenser is centered on the tissue oximetry probe.

FIG. 2B shows a simplified end view of the tissue oximetry probe where first and second dispensers are located outside of a circle of detectors.

FIG. 2C shows a tissue oximetry probe geometry for robust calibration and self-correction. In this figure, S2-detector distances are all equal and there are 14 unique distances between S1-detectors and S3-detectors combined (S1D1=S3D5 and S1D5=S3D1).

FIG. 3 shows a high-level flow diagram of a method for marking tissue to indicate ranges of oxygen saturation of the tissue.

FIG. 4 shows a cross-sectional view of the probe sensor assembly of the tissue oximetry device in one implementation.

FIGS. 5-6 show views of an LED board and a detector board of the probe sensor assembly 115. There are optical fiber connections between the LED and detector boards, which connect to the sensor openings.

FIGS. 7-12 show fiber optic connections of the probe sensor assembly in an implementation of the tissue oximeter device.

FIG. 8 shows the interface block of the LED PCB.

FIG. 9 shows the window location in the detector PCB for the sources S1, S2, and S3, as viewed from the component side of the detector PCB.

FIG. 10 shows a first cross-sectional view of the probe sensor assembly of FIG. 7.

FIG. 11 shows a second cross-sectional view of the probe sensor assembly of FIG. 7.

FIG. 12 shows a third cross-sectional view of view of the probe sensor assembly FIG. 7 where the optical fibers connect to the LED PCB.

DETAILED DESCRIPTION OF THE INVENTION

The present invention relates generally to a tissue oximetry device for measuring oxygen saturation in a local tissue volume. More specifically, the present invention relates to a wireless, handheld, tissue oximetry device that has self-contained optics (lights sources and detectors), computer processing, a display, a power-supply, and a tissue marker for marking tissue as the tissue is probed by the self-contained optics.

FIGS. 1A and 1B are a simplified perspective view and a top view, respectively, of a tissue oximetry device 100

according to one embodiment. The figures show an enclosure or housing of an oximeter probe device. Tissue oximetry device **100** is configured to make tissue oximetry measurements, such as intraoperatively and postoperatively.

In an implementation, the tissue oximetry device is handheld device and can make tissue oximetry measurements and display these measurements, without needing to connect to another external component either via a cable or wirelessly. The electronics to make measurements and calculations is contained entirely within the housing of the tissue oximetry device. The device may be a standalone handheld tissue oximetry device, without a cable or wireless connection.

Tissue oximetry device **100** may be a handheld device that includes a tissue oximetry probe **115** (also referred to as a sensor head), which may be positioned at an end of a sensing arm **114**. Tissue oximetry device **100** is configured to measure the oxygen saturation of tissue by emitting light, such as red and near-infrared light, from tissue oximetry probe **115** into tissue, and collecting light reflected from the tissue at the tissue oximetry probe.

Tissue oximetry device **100** may include a display **112** or other notification device (e.g., a speaker for audible notification) that notifies a user of oxygen saturation values measured by the tissue oximetry device. While tissue oximetry probe **115** is described as being configured for use with tissue oximetry device **100**, which is a handheld device, tissue oximetry probe **115** may be used with other tissue oximetry devices, such as a modular tissue oximetry device where the tissue oximetry probe is at the end of a cable device that couples to a base unit. The cable device might be a disposable device that is configured for use with a single patient and the base unit might be a device that is configured for repeated use. Such modular tissue oximetry devices are well understood by those of skill in the art and are not described further.

Tissue oximetry device **100** does not require a pulsing blood flow to make an oxygen saturation measurement as compared with pulse oximeters that require a pulsing blood flow to make such measurements. While the description of the example embodiments is directed toward tissue oximetry probes that do not require a pulsing blood flow for oxygen saturation measurements, embodiments of the present invention are not so limited and may be utilized with pulse oximeters.

FIG. 1C is a block diagram that shows tissue oximetry device **100** in further detail according to one embodiment. The components of device **100** are contained in a single enclosure or housing. Tissue oximetry device **100** may include display **112**, a processor **116**, a memory **117**, a speaker **118** (described briefly above), one or more input devices **119** (e.g., one or more switches, input buttons, keypad, display **112**, if for example, the display is a touch screen, or the like), a set of light sources **120**, a set of detectors **125**, a power source **127**, and a tissue marker **130**. Processor **116** may be a microcontroller, a microprocessor, control logic, a multicore processor, or the like, and may control the operation of light sources **120** and detectors **125**. Processor **116** may also control the operation of tissue marker **130**. Memory **117** may include a variety of memories, such as a volatile memory **117a** (e.g., a RAM), a nonvolatile memory **117** (e.g., a disk, Flash, PROM, or others), or both. User input may be by way of the input devices **119** (e.g., switches, touchpad, or the like).

Power source **127** can be a battery, such as a disposable battery. Disposable batteries are discarded after their stored charge is expended. Some disposable battery chemistry technologies include alkaline, zinc carbon, or silver oxide.

The battery has sufficient stored charged to allow use of the tissue oximetry device for several hours. After use, the tissue oximetry device is discarded.

In other implementations, the battery can also be rechargeable where the battery can be recharged multiple times after the stored charge is expended. Some rechargeable battery chemistry technologies include nickel cadmium (NiCd), nickel metal hydride (NiMH), lithium ion (Li-ion), and zinc air. The battery can be recharged, for example, via an AC adapter with cord that connects to the handheld unit. The circuitry in the tissue oximetry device can include a recharger circuit (not shown). Batteries with rechargeable battery chemistry may be sometimes used as disposable batteries, where the batteries are not recharged but disposed of after use.

Aspects of the invention may include software executable code or firmware (e.g., code stored in a read only memory or ROM chip). The software executable code or firmware may embody algorithms used in making oxygen saturation measurements of the tissue. The software executable code or firmware may include code to implement a user interface by which a user uses the system, displays results on the display, and selects or specifies parameters that affect the operation of the system.

The components may be linked together via a bus **128**, which may be the system bus architecture of tissue oximetry device **100**. Although this figure shows one bus that connects to each component, the busing is illustrative of any interconnection scheme serving to link these components or other components included in tissue oximetry device **100**. For example, speaker **118**, according to one specific implementation, could be connected to a subsystem through a port or have an internal direct connection to processor **116**.

The foregoing listed components may be housed in a mobile housing (see FIG. 1A) of tissue oximetry device **100**. However, different implementations of tissue oximetry device **100** may include alternative housing (such as the cables and the base units of modular oximeters described briefly above) and may include any number of the listed components, in any combination or configuration, and may also include other components not shown.

Tissue Oximetry Probe

FIG. 2A is a simplified end view of tissue oximetry probe **115** according to one embodiment. Tissue oximetry probe **115** is configured to contact tissue (e.g., a patient's skin) for which a tissue oximetry measurement is to be made. Tissue oximetry probe **115** includes the set of light sources **120** and the set of detectors **125**. The set of light sources **120** may include two or more light sources, such as light sources **120a** and **120b**.

Light sources **120** may be linearly positioned across tissue oximetry probe **115** and detectors **125** may be arranged in an arc or a circle (i.e., circular arrangement) on the tissue oximetry probe. More specifically, light sources **120** may be arranged linearly, such as on a line (e.g., a diameter) that bisects a circle on which detectors **125** may be arranged. The light sources **120a** and **120b** are spaced a distance $D1$ apart where $D1$ may range from about 3 millimeters to about 10 millimeters. That is, the circle on which detectors **125** are arranged may have a diameter of about 3 millimeters to about 10 millimeters (e.g., 4 millimeters according to one specific embodiment). While detectors **125** are described as being arranged in an arc or circle, tissue oximetry device **100** may have other configurations of detectors, such as linear, square, rectangular, ovoid, pseudo-random, or others.

Propagation depth increases with increasing source-to-detector distance, with 4-5 millimeters generally being a

sufficient upper limit between light sources **120a** and detectors **125** to ensure few detected photons propagated in lower tissue layers. For example, these distances between light sources **120** and detectors **125** limits reflectance data to light that propagated within the top layer of tissue where little or no underlying subcutaneous fat or muscular layers contribute to the reflectance data.

The set of detectors **125** may include four or more detectors. According to a specific embodiment, the set of detectors **125** includes eight detectors **125a**, **125b**, **125c**, **125d**, **125e**, **125f**, **125g**, and **125h** as shown. Detectors **125** are solid-state detectors and may be mounted to a PCB (not shown). Further, detectors **125** may be combined devices or discrete devices.

In a specific implementation, detectors **125** are positioned with respect to outer light sources **120a** and **120c** such that four or more (e.g., fourteen) unique source-to-detector distances are created. With greater numbers of source-to-detector distances, this can be used to obtain greater accuracy, faster calibration, and redundancy (when duplicate source-to-detector distances are provided). At least two source-to-detectors distances are 1.5 millimeters or closer, and at least two more two source-to-detectors distances are 2.5 millimeters or farther.

In other words, a first source-to-detector distance is about 1.5 millimeters or less. A second source-to-detector distance is about 1.5 millimeters or less. A third source-to-detector distance is about 2.5 millimeters or greater. A fourth source-to-detector distance is about 2.5 millimeters or greater. There can be various numbers of sources and detector arrangements to obtain these four source-to-detector distances, such as one source and four detectors, two sources and two detectors, one detector and four sources, or other arrangements and combinations.

For example, an implementation includes at least two sources and at least two detectors, where a maximum distance between a source and a detector is about 4 millimeters (or about 5 millimeters). At least two source-to-detector are about 2.5 millimeters or greater. At least two source-to-detector distances are about 1.5 millimeters or less.

When a greater number of sources and detectors are used, greater numbers of source-to-detector distances are available. As discussed, these can be used to provide greater accuracy, faster calibration, or redundancy, or a combination. The arrangement of the sources and detectors can be in circular pattern, such as at points along the arc of a circle with radius (e.g., 4 millimeters, or 5 millimeters). In an implementation, a tolerance of the detector or source positions on the arc is within 10 microns of the arc curve. In other implementations, the tolerance is within about 0.25 millimeters.

Tissue Marking

Turning now to tissue marker **130**, tissue oximetry probe **115** includes at least a dispenser portion of tissue marker **130**. FIG. 2 shows an end view of the dispenser that can dispense a marking material on a local tissue region (e.g., of an extended portion of tissue) that has been probed by tissue oximetry device **100**. The location of the marking material on tissue allows a user to subsequently identify the particular, local tissue region that has been probed.

The dispenser may be located at a variety positions on the face of tissue oximetry probe **115**. According to one specific embodiment, the dispenser is located between light sources **120a** and **120b**, and may be located at the approximate center of the circular arrangement of detectors **125**. With the dispenser at the approximate center of light sources **120** and

detectors **125**, a mark made by the dispenser will be substantially at a center of the local tissue region that has been probed by tissue oximetry device **100**. With the mark at the center of the probed tissue region, the mark is not displaced from the location on the local tissue region probed.

According to one implementation, tissue marker **130** includes one or more dispensers that may be located at different positions on the head of tissue oximetry probe **115**. FIG. 2B shows an embodiment where two dispensers are located “outside” of light sources **120** and detectors **125**. That is, the dispensers are located at the ends of radii that are longer than the radii of light sources **120** and detectors **125**. Further, the dispensers may lie on a line that passes through the center of the circle of the circular arrangement of dispensers **125**. With the dispensers located along such a line, marks made by these dispensers allow a user to readily identify the region between the marks as the local tissue region that has been probed by tissue oximetry device **100**.

While the dispensers shown in FIGS. 2A and 2B are shown as relatively localized devices (e.g., pen, pens, inker, inkers, and the like) that may be configured to mark tissue with relatively small marks (e.g., dots), a dispenser may be an extended device configured to make an extended mark, such as a line. For example, a dispenser may be an extended device configured to mark tissue with a circle or other closed shape, or may mark tissue with an open shape, such as a u-shape, a v-shape, or others.

The dispenser may be fixed within tissue oximetry probe **115** or may be configured to be lowered when tissue is marked. Various mechanical or electromechanical devices may be utilized by tissue oximetry probe **115** for lowering the dispenser. Such mechanical and electro-mechanical devices are well understood by those of skill in the art and are not described in detail herein.

Tissue marker **130** may mark tissue with a variety inks having a variety of colors, such as gentian violet, which is the tissue marking ink approved by the FDA. Variations in the gentian violet chemistry constituents can give different characteristics to the ink and cause changes in color or shade. Any of these colors or shades of gentian violet may be utilized by tissue marker **130**.

One or more of the ink colors utilized by tissue oximetry device **100** may indicate one or more oxygen saturation ranges. For example, tissue marker **130** might be configured to: (i) mark tissue with a first color of ink if the tissue’s oxygen saturation is at or below a first threshold, (ii) mark the tissue with a second color of ink if the tissue’s oxygen saturation is above the first threshold and at or below a second threshold, and (iii) mark the tissue with a third color of ink if the tissue’s oxygen saturation is above the second threshold. The foregoing example describes the use of three colors of ink for marking tissue for visually identifying three ranges of oxygen saturation, however more or fewer colors may be utilized by tissue marker **130** for identifying more or fewer oxygen saturation ranges.

Processor **116** may determine the oxygen saturation of a local tissue region based on an analysis of the reflection data that has been generated by detectors **125**, and may control tissue marker **130** to mark the local tissue region with a select color of ink that identifies the range that the oxygen saturation is within. Tissue marker **130** may include a variety of devices that provide marking material having one or more colors, such as ink reservoirs, pens, or the like. U.S. patent application Ser. No. 12/178,359, filed Jul. 23, 2008, of Heaton, titled “Oximeter with Marking Feature”, which is incorporated by reference in its entirety, describes a variety

of devices that are configured for marking tissue with one or more colors of marking material.

A reservoir of the marking device can be connected to the dispenser, such as through tubing or channels, and is contains ink or other fluid (e.g., ink) dispensed through the dispenser. Ink can be urged from the reservoir to and through the dispenser and deposited on skin through pressure or low-frequency sound (such using a piezoelectric transducer). The reservoir is contained within the same housing as the processor, battery, sources, detectors, and other components of the oximeter probe. For the disposable probe, the reservoir is not refillable.

According to one alternative, tissue marker **130**, under control of processor **116**, marks tissue for one or more oxygen saturation ranges, but does not mark the tissue for one or more other oxygen saturation regions. For example, tissue marker **130** might mark a local tissue region if the oxygen saturation of the local tissue region is at or below a threshold level, or alternatively might not mark the local tissue region if the oxygen saturation level is above the threshold level. Markings that are made on tissue according to the above method allow a user to relatively quickly identify tissue that might have a low chance of viability if the threshold level is relatively low. Alternatively, tissue marker **130** might mark a local tissue region if the oxygen saturation of the local tissue region is at or above a threshold level, and might not mark the local tissue region if the oxygen saturation level is below the threshold level. Marks made from this method allow a user to relatively quickly identify tissue that might have a relatively high chance of viability if the threshold level is relatively high.

Information for the foregoing described threshold levels (i.e., ranges) may be stored in memory **117** and accessed by processor **116** for use. The threshold levels may be stored in memory **117** during manufacture of tissue oximetry device **100**, or may be stored in the memory thereafter. For example, tissue oximetry device **100** may be configured to receive a user input for one or more user defined threshold levels and store information for these threshold levels in memory **117**. One or more input devices **119** (or the like) may be configured to receive a user input for a user defined threshold level and for storing the user defined threshold level in memory **117**.

FIG. **2C** shows an implementation of the geometry of a tissue oximetry probe **115b** for robust calibration and self-correction. The S2-detector (second source to detector) distances are all equal for tissue oximetry probe geometry **115b**. There are 14 unique distances between S1-detectors (first source to detectors) and S3-detectors (third source to detectors) combined for tissue oximetry probe geometry **115b**. Further, the distance between the first source and first detector is equal to the distance between the third source and the fifth detector (S1D1=S3D5), and the distance between the first source and fifth detector is equal to the distance between the third source and the first detector (S1D5=S3D1).

FIG. **3** is a high-level flow diagram of a method for marking tissue to indicate ranges of oxygen saturation of the tissue. The high-level flow diagram represents one example embodiment. Steps may be added to, removed from, or combined in the high-level flow diagram without deviating from the scope of the embodiment.

At **300**, tissue oximetry probe **115** contacts the tissue. Light (e.g., near-infrared light) is emitted from one or more of the light sources **120**, step **305**, into the tissue and at least some of the light is reflected back by the tissue. Each detector **125** receives a portion of the light reflected from the

tissue, step **310**, and each detector generates reflectance data (i.e., a response) for the portion of reflected light received, step **315**. At **320**, processor **305** determines an oxygen saturation value for the tissue based on the reflectance data. At **325**, processor **116** determines a range of oxygen saturation from a plurality of ranges of oxygen saturation in which the oxygen saturation lies. At **330**, processor **116** controls tissue marker **130** to mark the tissue with ink based on a range in which the oxygen saturation is in. For example, the processor may be configured to control the dispenser to mark the tissue with ink if the oxygen saturation is in a first range of oxygen saturation, but not mark the tissue if the oxygen saturation is in a second range of oxygen saturation where the first range and second range are different, such as not overlapping ranges. While the foregoing example embodiment, discusses the utilization of two ranges of oxygen saturation by the tissue oximetry device, the tissue oximetry device may utilize more than two ranges of oxygen saturation for determining whether to mark the tissue with ink.

According to one embodiment, the processor may control the dispenser to mark the tissue with a specific color of ink based on the range of oxygen saturation that the oxygen saturation is in. The particular color of ink allows a user to relatively quickly determine the ranges of oxygen saturation for the tissue without the need for re-probing the tissue or looking at a chart of the tissue that includes oxygen saturation values and matching the chart to the tissue.

FIG. **4** shows a cross-sectional view of a probe sensor assembly **115** of the tissue oximetry device in one implementation. The probe sensor assembly includes a printed circuit board (PCB) **400** with an aperture **410**. There are optic fibers having fiber cores **415** where each fiber core is positioned within a jacket. The optical fibers run through the PCB.

FIGS. **5-6** show views of an LED board and a detector board of the probe sensor assembly **115**. There are optical fiber connections between the LED and detector boards, which connect to the sensor openings.

FIGS. **7-12** show the fiber optic connections of the probe sensor assembly **115** in an implementation. FIG. **8** shows the interface block of the LED PCB.

FIG. **9** shows the window location in the detector PCB for the sources S1, S2, and S3, as viewed from the component side of the detector PCB. FIG. **10** shows the cross-sectional view C-C of FIG. **7** where the optical fibers enter the detector PCB and the tips of the optical fibers are flush with the surface of the aperture plate. FIG. **11** shows the cross-sectional view D-D of FIG. **7**. FIG. **12** shows the cross-sectional view E-E of FIG. **7** where the optical fibers connect to the LED PCB of the probe sensor assembly.

Tissue oximetry device **100** may be configured to allow a user to manually control the tissue oximetry device to mark tissue, allow processor **116** to control marking the tissue, or both. For example, one of input devices **119** may be configured to control tissue marker **130** to mark a local tissue region if a user activates the input device. The input device may be conveniently located for a user to operate tissue oximetry device **100** to make an oxygen saturation measurement, and operate the input device without moving tissue oximetry probe **115** from the local tissue region that was probed.

Tissue oximetry device **100** may be switched between the processor controlled method of marking tissue and the manually controlled method (e.g., activating one of the switches) of marking tissue. One or more other of input

devices **119** may be configured for switching tissue oximetry device **100** between these two methods of marking tissue.

This description of the invention has been presented for the purposes of illustration and description. It is not intended to be exhaustive or to limit the invention to the precise form described, and many modifications and variations are possible in light of the teaching above. The embodiments were chosen and described in order to best explain the principles of the invention and its practical applications. This description will enable others skilled in the art to best utilize and practice the invention in various embodiments and with various modifications as are suited to a particular use. The scope of the invention is defined by the following claims.

The invention claimed is:

1. A device comprising:

an oximeter probe contained within a single housing comprising:

a plurality of light sources comprising a first light source and a second light source, coupled to a probe face of the housing, configured to generate and emit light into a portion of an extended tissue region, wherein the sources are arranged along a line;

a first plurality of detectors, coupled to the probe face, wherein the first detectors are positioned on a first side of the line;

a second plurality of detectors, coupled to the probe face, wherein the second detectors are positioned on a second side of the line, opposite to the first side;

a first detector of the first plurality of detectors, wherein a first distance is from the first detector to the first source, a second distance is from the first detector to the second source, and the first distance is greater than the second distance;

a second detector of the second plurality of detectors, wherein a third distance is from the second detector to the first source, a fourth distance is from the second detector to the second source, and the fourth distance is greater than the third distance;

a third detector of the first plurality of detectors, wherein a fifth distance is from the third detector to the first source, a sixth distance is from the third detector to the second source, the fifth distance is different from the first distance and the second distance, and the sixth distance is different from the first distance and the second distance;

a fourth detector of the second plurality of detectors, wherein a seventh distance is from the fourth detector to the first source, an eighth distance is from the fourth detector to the second source, the seventh distance is different from the first, second, and fifth distances, and the eighth distance is different from the first, second, and sixth distances, and wherein the first distance is greater than the fifth, sixth, seventh, and eighth distances, and the second distance is less than the fifth, sixth, seventh, and eighth distances;

a processor, coupled to the light sources and detectors, configured to process reflectance data received from the detectors and determine oxygen saturation of the portion based on the reflectance data; and

a tissue marking component having a dispenser, coupled to the probe face, wherein the dispenser is located within an arrangement of the detectors and is configured to deposit ink onto the portion, thereby indicating that the portion has been evaluated by the probe.

2. The device of claim **1** wherein the arrangement of detectors is a noncircular arrangement.

3. The device of claim **1** wherein the oximeter probe contained within the single housing comprises a display visible from an exterior surface of the housing, the processor is adapted to process the reflectance data received from the detectors for radiation emitted into tissue by the sources, determine an oxygen saturation value for the tissue based on the reflectance data, control the display to display an indicator for the oxygen saturation value, control the tissue marking component for dispensing a first marking material from the dispenser if the oxygen saturation value is within a first range of oxygen saturation values and not within a second range of oxygen saturation values, and the first and second ranges of oxygen saturation values are different ranges.

4. The device of claim **3** wherein the processor is adapted to control the tissue marking component for dispensing a second marking material from the dispenser onto the tissue if the oxygen saturation value is within the second range of oxygen saturation values, and the first and second marking materials have first and second colors that are different colors.

5. The device of claim **3** wherein the device is a handheld, standalone unit, when the handheld device is used, the housing comprising the processor, and the display of the device is cradled on a pulicue between a thumb and forefinger of a hand of a user while the display is at a proximal end of the device and a tip portion of the housing extends in a distal direction to a distal end of the device, and while the device is in the user's hand, the user positions the probe face that is at the distal end of the device on the tissue to be measured.

6. The device of claim **1** wherein the second distance is the same as the third distance.

7. The device of claim **1** wherein the first distance is the same as the fourth distance and the second distance is the same as the third distance.

8. The device of claim **1** wherein the arrangement of detectors is a circular arrangement.

9. The device of claim **1** wherein the light sources are positioned on the line, separated by a ninth distance, and the ninth distance is greater than the first distance and the fourth distance.

10. A device comprising:

an oximeter probe contained within a single housing comprising:

a plurality of source structures comprising a first source structure and a second source structure, located on a probe face of the housing, configured to emit light into a portion of an extended tissue region, wherein the sources structures are arranged along a line on the probe face;

a plurality of detector structures, located on the probe face, wherein the detector structures are configured to detect the light subsequent to reflection from the portion;

a first detector structure and a third detector structure of the plurality of detector structures are located on a first side of the line and a second detector structure and a fourth detector structure of the plurality of detector structures are located on a second side of the line, wherein

a first distance is from the first detector structure to the first source structure, a second distance is from the first detector structure to the second source structure, and the first distance is greater than the second distance, a third distance is from the second detector structure to the first source structure, a fourth distance is from the

second detector structure to the second source structure, and the fourth distance is greater than the third distance,

a fifth distance is from the third detector structure to the first source structure, a sixth distance is from the third detector structure to the second source structure, the fifth distance is different from the first distance and the second distance, and the sixth distance is different from the first distance and the second distance,

a seventh distance is from the fourth detector structure to the first source structure, an eighth distance is from the fourth detector structure to the second source structure, the seventh distance is different from the first, second, and fifth distances, and the eighth distance is different from the first, second, and sixth distances,

the first distance is greater than the fifth, sixth, seventh, and eighth distances, and

the second distance is less than the fifth, sixth, seventh, and eighth distances;

a processor contained within the single housing configured to process reflectance data for the light collected by the detector structures and determine an oxygen saturation of the portion based on the reflectance data; and

a tissue marking component having a dispenser, coupled to the probe face, wherein the dispenser is located within an arrangement of the detector structures and is configured to deposit ink onto the portion, thereby indicating that the portion has been evaluated by the probe.

11. The device of claim 10 wherein the first distance is greater than the fifth, sixth, seventh, and eighth distances, and the second distance is less than the fifth, sixth, seventh, and eighth distances.

12. The device of claim 11 wherein the first distance is the same as the fourth distance, and the second distance is the same as the third distance.

13. The device of claim 10 wherein the processor is adapted to process the reflectance data received from the detector structures for radiation emitted into tissue by the source structures, determine an oxygen saturation value for the tissue based on the reflectance data, control the tissue marking component for dispensing a first marking material from the dispenser if the oxygen saturation value is within a first range of oxygen saturation values and not within a second range of oxygen saturation values, and the first and second ranges of oxygen saturation values are different ranges.

14. The device of claim 13 wherein the processor is adapted to control the tissue marking component for dispensing a second marking material from the dispenser onto the tissue if the oxygen saturation value is within the second range of oxygen saturation values, and the first and second marking materials have first and second colors that are different colors.

15. The device of claim 10 wherein the device is a handheld, standalone unit, when the handheld device is used, the housing comprising the processor and a display of the device is cradled on a pulcruc between a thumb and forefinger of a hand of a user while the display is at a proximal end of the device and a tip portion of the housing extends in a distal direction to a distal end of the device, and while the device is in the user's hand, the user positions the probe face that is at the distal end of the device on the tissue to be measured.

16. A device comprising:
an oximeter probe contained within a single housing comprising:

a plurality of source structures, located on a probe face of the housing, configured to emit light into a portion of an extended tissue region, wherein the source structures are arranged along a line on the probe face;

a plurality of detector structures, located on the probe face, wherein the detector structures are positioned in an arrangement and configured to detect the light subsequent to reflection from the portion, wherein there are an equal number of detector structures on either side of the line, and wherein a first distance is from a first detector structure of the plurality of detector structures to a first source structure of the plurality of source structures, a second distance is from the first detector structure to a second source structure of the plurality of source structures, and the first distance is greater than the second distance,

a third distance is from a second detector structure of the plurality of detector structures to the first source structure, a fourth distance is from the second detector structure to the second source structure, and the fourth distance is greater than the third distance,

a fifth distance is from a third detector structure of the plurality of detector structures to the first source structure, a sixth distance is from the third detector structure to the second source structure, the fifth distance is different from the first distance and the second distance, and the sixth distance is different from the first distance and the second distance,

a seventh distance is from a fourth detector structure of the plurality of detector structures to the first source structure, an eighth distance is from the fourth detector structure to the second source structure, the seventh distance is different from the first, second, and fifth distances, and

the eighth distance is different from the first, second, and sixth distances;

a processor contained within the single housing configured to process reflectance data for the light collected by the detector structures and determine an oxygen saturation of the portion based on the reflectance data;

a display visible from an exterior of the single housing and coupled to the processor; and

a tissue marking component having a dispenser, coupled to the probe face, wherein the dispenser is located on the line and is configured to deposit ink onto the portion, thereby indicating that the portion has been evaluated by the probe.

17. The device of claim 16 wherein the dispenser is positioned between the source structures.

18. The device of claim 16 wherein the processor is adapted to process the reflectance data received from the detector structures for radiation emitted into tissue by the source structures, determine an oxygen saturation value for the tissue based on the reflectance data, control the tissue marking component for dispensing a first marking material from the dispenser if the oxygen saturation value is within a first range of oxygen saturation values and not within a second range of oxygen saturation values, and the first and second ranges of oxygen saturation values are different ranges.

19. The device of claim 16 wherein the device is a handheld, standalone unit, when the handheld device is used, the housing comprising the processor and display, of the device is cradled on a pulcruc between a thumb and forefinger of a hand of a user while the display is at a

proximal end of the device and a tip portion of the housing extends in a distal direction to a distal end of the device, and while the device is in the user's hand, the user positions the probe face that is at the distal end of the device on the tissue to be measured.

5

20. The device of claim **16** comprising:
a first source diode and a second source diode;
a first optical fiber optically coupled between the first source diode and the first source structure; and
a second optical fiber optically coupled between the
second source diode and the second source structure,
wherein the first optical fiber transmits radiation emitted by the first source diode to the first source structure, and the second optical fiber transmits radiation emitted by the second source diode to the second source structure.

10

15

* * * * *

专利名称(译)	具有组织标记功能的组织血氧饱和度探头		
公开(公告)号	US10524705	公开(公告)日	2020-01-07
申请号	US15/214355	申请日	2016-07-19
[标]申请(专利权)人(译)	维奥普蒂克斯公司		
申请(专利权)人(译)	VIOPTIX INC.		
当前申请(专利权)人(译)	VIOPTIX INC.		
[标]发明人	BECHTEL KATE LEEANN HEANUE JOSEPH ANTHONY LLOYD LESTER JOHN		
发明人	BECHTEL, KATE LEEANN HEANUE, JOSEPH ANTHONY LLOYD, LESTER JOHN		
IPC分类号	A61B5/1455 A61B5/1459 A61B90/11 A61B5/145 A61M35/00 A61B5/00 A61B90/00 A61B5/1495 A61B90/30		
CPC分类号	A61B90/39 A61B5/742 A61B90/11 A61B5/0059 A61B5/7475 A61M35/003 A61B5/7405 A61B5/1455 A61B5/14546 A61B5/1459 A61B5/14552 A61B5/14551 A61B5/1495 A61B5/7246 A61B5/72 A61B5/74 A61B5/7282 A61B5/0075 A61B2090/395 A61B2562/0271 A61B2560/0475 A61B2090/065 A61B2090/306 A61B2560/0431 A61B2562/166		
优先权	61/642395 2012-05-03 US 61/642393 2012-05-03 US 61/642389 2012-05-03 US 61/642399 2012-05-03 US 61/682146 2012-08-10 US		
其他公开文献	US20160324453A1		
外部链接	Espacenet		

摘要(译)

术中组织血氧饱和度测定装置包括组织标记物，该组织标记物包括一支或多支笔或一种或多种类似的墨水源，使得该组织标记物可以根据组织血氧饱和度测定装置进行的氧饱和度测量来标记组织，从而在视觉上描绘出潜在可行的区域 来自潜在无效组织区域的组织。

