



US009152765B2

(12) **United States Patent**
Gilham et al.

(10) **Patent No.:** **US 9,152,765 B2**
(45) **Date of Patent:** **Oct. 6, 2015**

- (54) **MULTI-DISPLAY BEDSIDE MONITORING SYSTEM**
- (71) Applicant: **Spacelabs Healthcare**, Snoqualmie, WA (US)
- (72) Inventors: **Jeffrey Jay Gilham**, Sammamish, WA (US); **Patrick Jensen**, Sammamish, WA (US); **Michael Brendel**, Issaquah, WA (US); **Katherine Stankus**, Woodinville, WA (US)
- (73) Assignee: **Spacelabs Healthcare LLC**, Snoqualmie, WA (US)
- (*) Notice: Subject to any disclaimer, the term of this patent is extended or adjusted under 35 U.S.C. 154(b) by 0 days.

- (21) Appl. No.: **14/165,193**
- (22) Filed: **Jan. 27, 2014**

- (65) **Prior Publication Data**
US 2014/0203937 A1 Jul. 24, 2014

- Related U.S. Application Data**
- (63) Continuation of application No. 13/052,883, filed on Mar. 21, 2011, now Pat. No. 8,674,837.
- (60) Provisional application No. 61/315,967, filed on Mar. 21, 2010.

- (51) **Int. Cl.**
G08B 23/00 (2006.01)
G06F 19/00 (2011.01)
(Continued)

- (52) **U.S. Cl.**
CPC **G06F 19/3406** (2013.01); **A61B 5/002** (2013.01); **G06F 3/1438** (2013.01); **G06F 19/322** (2013.01); **G06F 19/345** (2013.01); **G06F 19/3487** (2013.01); **G09G 2380/08** (2013.01)

- (58) **Field of Classification Search**
CPC G06F 19/3406; G06F 19/322; G06F 2380/08
USPC 340/573.1, 573.4, 691.1, 540, 541, 3.2; 600/324, 347, 384, 509, 515
See application file for complete search history.

- (56) **References Cited**
U.S. PATENT DOCUMENTS
2,912,858 A 11/1959 Fuller
3,517,639 A 6/1970 Whitsel
(Continued)

- FOREIGN PATENT DOCUMENTS
CN 1688256 10/2005
CN 101194278 6/2008
(Continued)

- OTHER PUBLICATIONS
Chinese Office Action, Patent Application No. 201180025170X, Issued Apr. 21, 2014, First OA.
(Continued)

Primary Examiner — Tai T Nguyen
(74) *Attorney, Agent, or Firm* — Novel IP

(57) **ABSTRACT**
The present specification discloses systems and methods for patient monitoring using a multitude of display regions, at least two of which have the capability to simultaneously display real time patient waveforms and vital statistics as well as provide display for local and remote software applications. In one example, a primary display shows real time patient waveforms and vital statistics while a customizable secondary display shows trends, cumulative data, laboratory and radiology reports, protocols, and similar clinical information. Additionally, the secondary display can launch local and remote applications such as entertainment software, Internet and email programs, patient education software, and video conferencing applications. The dual display allows caregivers to simultaneously view real time patient vitals and aggregated data or therapy protocols, thereby increasing hospital personnel efficiency and improving treatment, while not compromising the display of critical alarms or other data.

18 Claims, 11 Drawing Sheets

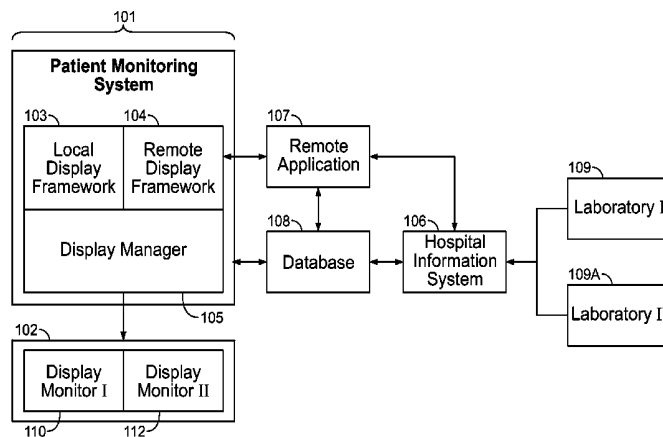

(51)	Int. Cl.							
	<i>G06F 3/14</i>	(2006.01)						
	<i>A61B 5/00</i>	(2006.01)						
(56)	References Cited							
	U.S. PATENT DOCUMENTS							
	3,618,592 A	11/1971	Stewart	6,131,571 A	10/2000	Lampotang		
	3,673,863 A	7/1972	Spacek	6,134,537 A	10/2000	Pao		
	3,938,551 A	2/1976	Henkin	6,146,523 A	11/2000	Kenley		
	4,064,826 A	12/1977	Pauli	6,155,255 A	12/2000	Lambert		
	4,148,312 A	4/1979	Bird	6,322,502 B1	11/2001	Schoenberg		
	4,167,115 A	9/1979	Stoever	6,338,823 B1	1/2002	Furukawa		
	4,513,294 A	4/1985	Anderson	6,339,732 B1	1/2002	Phoon		
	4,557,216 A	12/1985	Demyon	6,347,310 B1	2/2002	Passera		
	4,625,731 A	12/1986	Quedens	6,383,136 B1	5/2002	Jordan		
	4,630,486 A	12/1986	Miles	6,396,583 B1	5/2002	Clare		
	4,697,450 A	10/1987	Bachman	6,424,860 B1	7/2002	Karlsson		
	4,869,253 A	9/1989	Craig	6,435,690 B1	8/2002	Till		
	4,903,222 A	2/1990	Carter	6,443,889 B1	9/2002	Groth		
	4,944,305 A	7/1990	Takatsu	D467,001 S	12/2002	Buczek		
	4,991,576 A	2/1991	Henkin	6,488,029 B1	12/2002	Hood		
	5,087,906 A	2/1992	Eaton	6,536,430 B1	3/2003	Smith		
	5,101,851 A	4/1992	Abadi	6,554,238 B1	4/2003	Hibberd		
	5,144,898 A	9/1992	Posly	6,571,227 B1	5/2003	Agrafiotis		
	5,197,480 A	3/1993	Gebhardt	6,571,792 B1	6/2003	Hendrickson		
	5,213,108 A	5/1993	Bredesen	6,591,694 B2	7/2003	Tsai		
	5,231,981 A	8/1993	Schreiber	6,600,662 B1	7/2003	Emmert		
	5,233,975 A	8/1993	Choate	6,647,341 B1	11/2003	Golub		
	5,262,944 A	11/1993	Weisner	6,650,779 B2	11/2003	Vachtrsvanos		
	5,291,182 A	3/1994	Wiseman	6,674,837 B1	1/2004	Taskar		
	5,311,908 A	5/1994	Barone	6,692,258 B1	2/2004	Kurzweil		
	5,319,363 A	6/1994	Welch	6,692,436 B1	2/2004	Bluth		
	5,322,069 A	6/1994	Gallant	6,699,187 B2	3/2004	Webb		
	5,331,549 A	7/1994	Crawford, Jr.	6,702,754 B2	3/2004	Ogura		
	5,339,826 A	8/1994	Schmidt	6,715,722 B2	4/2004	Roberts		
	5,348,008 A	9/1994	Born	6,735,648 B2	5/2004	Onishi		
	5,373,746 A	12/1994	Bloss	6,771,172 B1	8/2004	Robinson		
	5,419,332 A	5/1995	Sabbah	6,804,656 B1	10/2004	Rosenfeld		
	5,438,983 A	8/1995	Falcone	6,824,539 B2	11/2004	Novak		
	5,467,954 A	11/1995	Wekell	6,829,501 B2	12/2004	Nielsen		
	5,473,536 A	12/1995	Wimmer	6,931,795 B1	8/2005	Baloga		
	5,482,050 A	1/1996	Smokoff	6,933,931 B2	8/2005	Lubarsky, Jr.		
	5,497,766 A	3/1996	Foster	6,985,762 B2	1/2006	Brashears		
	5,502,853 A	4/1996	Singleton	7,006,865 B1 *	2/2006	Cohen et al. 607/5		
	5,515,083 A	5/1996	Casebolt	7,013,833 B2	3/2006	Lemberger		
	5,553,296 A	9/1996	Forrest	7,024,569 B1	4/2006	Wright		
	5,558,418 A	9/1996	Lambright	7,031,857 B2	4/2006	Tarassenko		
	5,563,495 A	10/1996	Tomiyori	7,038,588 B2	5/2006	Boone		
	5,584,291 A	12/1996	Vapola	7,076,435 B1	7/2006	McKeag		
	5,586,909 A	12/1996	Saba	7,081,091 B2	7/2006	Merrett		
	5,633,457 A	5/1997	Kilar	RE39,233 E	8/2006	McGrath		
	5,682,526 A	10/1997	Smokoff	7,096,864 B1	8/2006	Mayer		
	5,687,717 A	11/1997	Halpern	7,111,852 B2	9/2006	Woods		
	5,692,494 A	12/1997	Pernetti	7,117,438 B2	10/2006	Wallace		
	5,715,813 A	2/1998	Guevrekian	7,137,951 B2	11/2006	Pilarski		
	5,718,235 A	2/1998	Golosarsky	7,193,233 B2	3/2007	Smith		
	5,724,025 A	3/1998	Tavori	7,223,007 B1	5/2007	Fredley		
	5,724,985 A	3/1998	Snell	7,256,708 B2	8/2007	Rosenfeld		
	5,749,367 A	5/1998	Gamlyn	7,267,666 B1	9/2007	Duchon		
	5,765,842 A	6/1998	Phaneuf	7,282,029 B1	10/2007	Poulsen		
	5,779,305 A	7/1998	Hocking	7,315,825 B2	1/2008	Rosenfeld		
	5,787,298 A	7/1998	Broedner	7,336,980 B1	2/2008	Kaikuranta		
	5,800,360 A	9/1998	Kisner	7,360,454 B2	4/2008	Kawashima		
	5,819,741 A	10/1998	Karlsson	7,371,214 B2	5/2008	Kouchi		
	5,855,550 A	1/1999	Lai	7,386,340 B2	6/2008	Schlegel		
	5,868,133 A	2/1999	DeVries	7,468,032 B2	12/2008	Stahmann		
	5,904,328 A	5/1999	Leveridge	7,469,601 B2	12/2008	Sugi		
	5,956,013 A	9/1999	Raj	D589,959 S	4/2009	Han		
	5,975,081 A	11/1999	Hood	7,516,924 B2	4/2009	White		
	6,005,767 A	12/1999	Ku	7,523,040 B2	4/2009	Kirchhoff		
	6,024,089 A	2/2000	Wallace	7,529,083 B2	5/2009	Jeong		
	6,048,044 A	4/2000	Biggel	7,540,187 B1	6/2009	Dillon		
	6,050,940 A	4/2000	Braun	7,566,307 B2	7/2009	Inukai		
	6,063,028 A	5/2000	Luciano	7,621,500 B2	11/2009	Ishizaki		
	6,096,025 A	8/2000	Borders	7,751,878 B1	7/2010	Merkle		
	6,099,093 A	8/2000	Spence	7,756,722 B2	7/2010	Levine		
				7,945,452 B2	5/2011	Fathallah		
				8,027,846 B2 *	9/2011	Schoenberg et al. 705/2		
				8,147,419 B2 *	4/2012	Krauss et al. 600/529		
				8,344,847 B2	1/2013	Moberg		
				2001/0001179 A1	5/2001	Healy		
				2001/0018332 A1	8/2001	Lustila		
				2001/0027791 A1	10/2001	Wallace		
				2001/0034475 A1	10/2001	Flach		
				2002/0026941 A1	3/2002	Biondi		

(56)		References Cited			
		U.S. PATENT DOCUMENTS			
				2007/0120763	A1 5/2007 De
				2007/0176931	A1 8/2007 Tivig
				2007/0180140	A1 8/2007 Welch
				2007/0199388	A1 8/2007 Furkert
				2007/0255116	A1 11/2007 Mehta
				2007/0265533	A1 11/2007 Tran
				2007/0276277	A1 11/2007 Booth
				2008/0033254	A1 2/2008 Kamath
				2008/0039701	A1 2/2008 Ali
				2008/0051667	A1 2/2008 Goldreich
				2008/0154909	A1 6/2008 Dam
				2008/0167569	A1 7/2008 Ermes
				2008/0170287	A1 7/2008 Champion
				2008/0177160	A1 7/2008 Al Ali
				2008/0177397	A1 7/2008 Davlin
				2008/0221418	A1 9/2008 Al-Ali
				2008/0228089	A1 9/2008 Cho
				2008/0249376	A1 10/2008 Zaleski
				2008/0251003	A1 10/2008 Boston
				2008/0271736	A1 11/2008 Leonard
				2008/0275309	A1 11/2008 Stivoric
				2008/0281168	A1 11/2008 Gibson
				2008/0281170	A1 11/2008 Eshelman
				2008/0287763	A1 11/2008 Hayter
				2008/0294057	A1 11/2008 Parlikar
				2008/0310600	A1 12/2008 Clawson
				2008/0319331	A1 12/2008 Zizzo
				2009/0005703	A1 1/2009 Fasciano
				2009/0015116	A1 1/2009 Arceta
				2009/0024008	A1 1/2009 Brunner
				2009/0054743	A1 2/2009 Stewart
				2009/0069642	A1 3/2009 Gao
				2009/0076345	A1 3/2009 Manicka
				2009/0099480	A1 4/2009 Salgo
				2009/0117784	A1 5/2009 Wu
				2009/0124239	A1 5/2009 Tsuei
				2009/0131805	A1* 5/2009 O'Brien et al. 600/485
				2009/0133609	A1 5/2009 Nethken
				2009/0149901	A1 6/2009 Jayne
				2009/0182204	A1 7/2009 Semler
				2009/0192541	A1 7/2009 Ortiz
				2009/0193315	A1 7/2009 Gower
				2009/0200902	A1 8/2009 McKay
				2009/0206713	A1 8/2009 Vilkas
				2009/0209849	A1 8/2009 Rowe
				2010/0004539	A1 1/2010 Chen
				2010/0007588	A1 1/2010 Zygmunt
				2010/0056875	A1 3/2010 Schoenberg
				2010/0094096	A1 4/2010 Petruzzelli
				2010/0137729	A1 6/2010 Pierry
				2010/0164452	A1 7/2010 Ruan
				2010/0175695	A1 7/2010 Jamison
				2010/0179400	A1 7/2010 Brauker
				2010/0233891	A1 9/2010 Broeksteeg
				2010/0238138	A1 9/2010 Goertz
				2010/0261979	A1 10/2010 Kiani
				2010/0294405	A1 11/2010 Longinotti-Buitoni
				2010/0298656	A1 11/2010 McCombie
				2010/0298718	A1 11/2010 Gilham
				2010/0324380	A1 12/2010 Perkins
				2010/0324384	A1 12/2010 Moon
				2011/0004071	A1 1/2011 Faiola
				2011/0088694	A1 4/2011 Tobia
				2011/0130798	A1 6/2011 Elghazzawi
				2011/0152629	A1 6/2011 Eaton
				2011/0164074	A1 7/2011 Frank
				2011/0245579	A1 10/2011 Bruggeman
				2011/0257489	A1 10/2011 Banet
				2011/0279383	A1 11/2011 Wilson
				2011/0279958	A1 11/2011 Clark
				2012/0030610	A1 2/2012 DiPerna
				2012/0075327	A1 3/2012 Mackenzie
				2012/0105233	A1 5/2012 Bobey
				2012/0127103	A1 5/2012 Qualey
				2012/0209984	A1 8/2012 Gonzalez-Banos
2002/0032386	A1 3/2002	Sackner			
2002/0108011	A1 8/2002	Tanha			
2002/0161291	A1 10/2002	Kianl			
2002/0193679	A1 12/2002	Malave			
2002/0196141	A1*	Boone et al.	340/540		
2003/0028118	A1 2/2003	Dupree			
2003/0029451	A1 2/2003	Blair			
2003/0037786	A1 2/2003	Biondi			
2003/0076015	A1 4/2003	Ehrenreich			
2003/0114836	A1 6/2003	Estes			
2003/0117296	A1 6/2003	Seely			
2003/0120164	A1 6/2003	Nielsen			
2003/0130590	A1 7/2003	Bui			
2003/0135087	A1 7/2003	Hickle			
2003/0145854	A1 8/2003	Hickle			
2003/0171898	A1 9/2003	Tarassenko			
2003/0191373	A1 10/2003	Blike			
2003/0209246	A1 11/2003	Schroeder			
2003/0210780	A1 11/2003	Pratt			
2003/0216621	A1 11/2003	Alpert			
2003/0231460	A1 12/2003	Moscovitch			
2003/0233129	A1 12/2003	Matos			
2004/0011938	A1 1/2004	Oddsden			
2004/0015079	A1 1/2004	Berger			
2004/0021705	A1 2/2004	Baker			
2004/0024303	A1 2/2004	Banks			
2004/0032426	A1 2/2004	Rutledge			
2004/0054261	A1 3/2004	Kamatagi			
2004/0054295	A1 3/2004	Ramseth			
2004/0102687	A1 5/2004	Brashears			
2004/0103001	A1 5/2004	Mazar			
2004/0116813	A1 6/2004	Selzer			
2004/0117209	A1 6/2004	Brown			
2004/0118404	A1 6/2004	Wallace			
2004/0147818	A1 7/2004	Levy			
2004/0153257	A1 8/2004	Munk			
2004/0158132	A1 8/2004	Zaleski			
2004/0172222	A1 9/2004	Simpson			
2004/0186357	A1 9/2004	Soderberg			
2004/0221077	A1 11/2004	Yen			
2004/0236192	A1 11/2004	NecolaShehada			
2004/0249298	A1 12/2004	Selevan			
2004/0249673	A1 12/2004	Smith			
2005/0005932	A1 1/2005	Berman			
2005/0010165	A1 1/2005	Hickle			
2005/0033124	A1 2/2005	Kelly			
2005/0038332	A1 2/2005	Saidara			
2005/0038821	A1 2/2005	Wallen			
2005/0054920	A1 3/2005	Washburn			
2005/0059924	A1 3/2005	Katz			
2005/0065417	A1 3/2005	Ali			
2005/0113650	A1 5/2005	Pacione			
2005/0124866	A1 6/2005	Elaz			
2005/0139213	A1 6/2005	Blike			
2005/0146431	A1 7/2005	Hastings			
2005/0151640	A1 7/2005	Hastings			
2005/0251232	A1 11/2005	Hartley			
2006/0004475	A1 1/2006	Brackett			
2006/0022096	A1 2/2006	Chan			
2006/0042635	A1 3/2006	Niklewski			
2006/0058591	A1 3/2006	Garboski			
2006/0094970	A1 5/2006	Drew			
2006/0155206	A1 7/2006	Lynn			
2006/0199618	A1 9/2006	Steer			
2006/0226992	A1 10/2006	Al-Ali			
2006/0258926	A1 11/2006	Ali			
2006/0280621	A1 12/2006	Kinugawa			
2007/0007418	A1 1/2007	Lubbers			
2007/0028921	A1 2/2007	Banner			
2007/0032749	A1 2/2007	Overall			
2007/0044578	A1 3/2007	Jones			
2007/0051861	A1 3/2007	Teramachi			
2007/0060869	A1 3/2007	Tolle			
2007/0093784	A1 4/2007	Leonard			
2007/0107728	A1 5/2007	Ricciardelli			

(56)

References Cited

U.S. PATENT DOCUMENTS

2012/0232398 A1 9/2012 Roham
2013/0267861 A1 10/2013 Vassallo

FOREIGN PATENT DOCUMENTS

EP 0686900 A2 12/1995
EP 1054338 11/2000
EP 1852060 11/2007
GB 2389290 A 12/2003
JP 07163527 6/1995
JP 2003210422 7/2003
WO 9415523 7/1994
WO 9918705 4/1999
WO 03091841 11/2003
WO 03102850 12/2003
WO 2006094055 A2 9/2006
WO 2010126916 11/2010
WO 2010126916 A1 11/2010
WO 2011001302 A1 1/2011
WO 2011046636 A1 4/2011
WO 2011047363 A1 4/2011
WO 2011119512 A1 9/2011
WO 2012068564 A2 5/2012
WO 2012068565 A2 5/2012
WO 2012068567 5/2012
WO 2012068568 A2 5/2012
WO 2012083276 A2 6/2012
WO 2012083281 A1 6/2012
WO 2012125135 A1 9/2012
WO 2012128808 A2 9/2012
WO 2012158720 A1 11/2012
WO 2013056171 A2 4/2013
WO 2013173520 A2 11/2013
WO 2013173521 A2 11/2013
WO 2014055660 A1 4/2014
WO 2014194193 12/2014

OTHER PUBLICATIONS

Office Action Dated May 31, 2013 for U.S. Appl. No. 13/052,883.
International Search Report for PCT/US2011/029278, Aug. 2, 2011.
International Search Report for PCT/US2013/063087, Mar. 6, 2014.
Supplementary European Search Report, Nov. 25, 2009, Spacelabs Medical, PCT/US2006/007269.
Schoenberg, Roy, MD; Sands, Daniel Z., MD MPH; Safran, Charles, MD; Center for Clinical Computing, Beth Israel Deaconess Medical Center, Harvard Medical School, "Making ICU Alarms Meaningful: a comparison of traditional vs. trend-based algorithms" (AMIA '99 Annual Symposium), 1999, pp. 1-5.
International Search Report for PCT/US06/07269, Aug. 28, 2006.
International Preliminary Report on Patentability, PCT/US2006/007269, Sep. 11, 2007, Spacelabs Medical.
Notice of Allowance dated Oct. 31, 2014 for U.S. Appl. No. 12/114,689.

International Search Report for PCT/US10/32635, Jul. 23, 2010.
Office Action dated Feb. 26, 2015 for U.S. Appl. No. 12/768,714.
Office Action dated Aug. 14, 2014 for U.S. Appl. No. 12/768,714.
Office Action dated Nov. 21, 2013 for U.S. Appl. No. 12/768,714.
Office Action dated Jun. 18, 2012 for U.S. Appl. No. 12/768,714.
Office Action dated Jan. 17, 2013 for U.S. Appl. No. 12/768,714.
International Search Report for PCT/US2011/61557, Apr. 23, 2012.
International Search Report for PCT/US2011/061554, Feb. 14, 2014.
International Search Report for PCT/US2011/061555, Apr. 17, 2012.
International Search Report for PCT/US2011/061558, Aug. 10, 2012.
International Preliminary Report on Patentability for PCT/US2011/061554, Feb. 25, 2014.
IntelliVue Patient Monitor; MP20/30, MP40/50, MP60/70/80/90, Release G.0 with Software Revision G.0x.xx (PHILIPS) Sep. 2008; pp. 4, 10, 19, 20, 46-49, 82, 326, 348, 420, 422, 424, 452; Accessed on Sep. 30, 2013: <http://www.mc.vanderbilt.edu/documents/nursingeducationresources/files/MP20-MP90%20Instructions%20for%20Use%20Manual%20Rev_G_0%20%20English%20M8000-9001K.pdf>.
Office Action dated Nov. 12, 2014 for U.S. Appl. No. 13/300,462.
Notice of Allowance dated Jan. 28, 2015 for U.S. Appl. No. 13/300,478.
International Search Report, PCT/US2011/028007, Jul. 11, 2011, International Search Authority.
International Preliminary Report on Patentability, PCT/US2011/028007, Sep. 17, 2013, International Search Authority.
Office Action dated Nov. 21, 2014 for U.S. Appl. No. 13/045,539.
International Preliminary Report on Patentability, PCT/US12/38000, Nov. 13, 2013.
International Search Report for PCT/US12/38000, Oct. 23, 2012.
International Search Report for PCT/US10/34025, Aug. 9, 2010.
Notice of Allowance dated Mar. 13, 2015 for U.S. Appl. No. 12/906,081.
International Search Report for PCT/US2012/060125, Apr. 19, 2013.
International Search Report for PCT/US2010/052977, Mar. 18, 2011.
International Search Report for PCT/US2011/065676, Sep. 20, 2012.
International Search Report for PCT/US2011/065678, Jun. 29, 2012.
International Search Report, PCT/US2011/065685, May 8, 2012, International Search Authority.
International Preliminary Report on Patentability, PCT/US2011/065678, Jun. 18, 2013, International Search Authority.
International Preliminary Report on Patentability, PCT/US2011/065685, Jun. 18, 2013.
Office Action dated Sep. 22, 2014 for U.S. Appl. No. 13/329,186.
Notice of Allowance dated Jan. 8, 2015 for U.S. Appl. No. 13/329,259.
International Search Report for PCT/US2014/040225, Nov. 5, 2014.
International Search Report for PCT/US2013/041246, Dec. 9, 2013.
International Search Report for PCT/US2013/041247, Jan. 10, 2014.

* cited by examiner

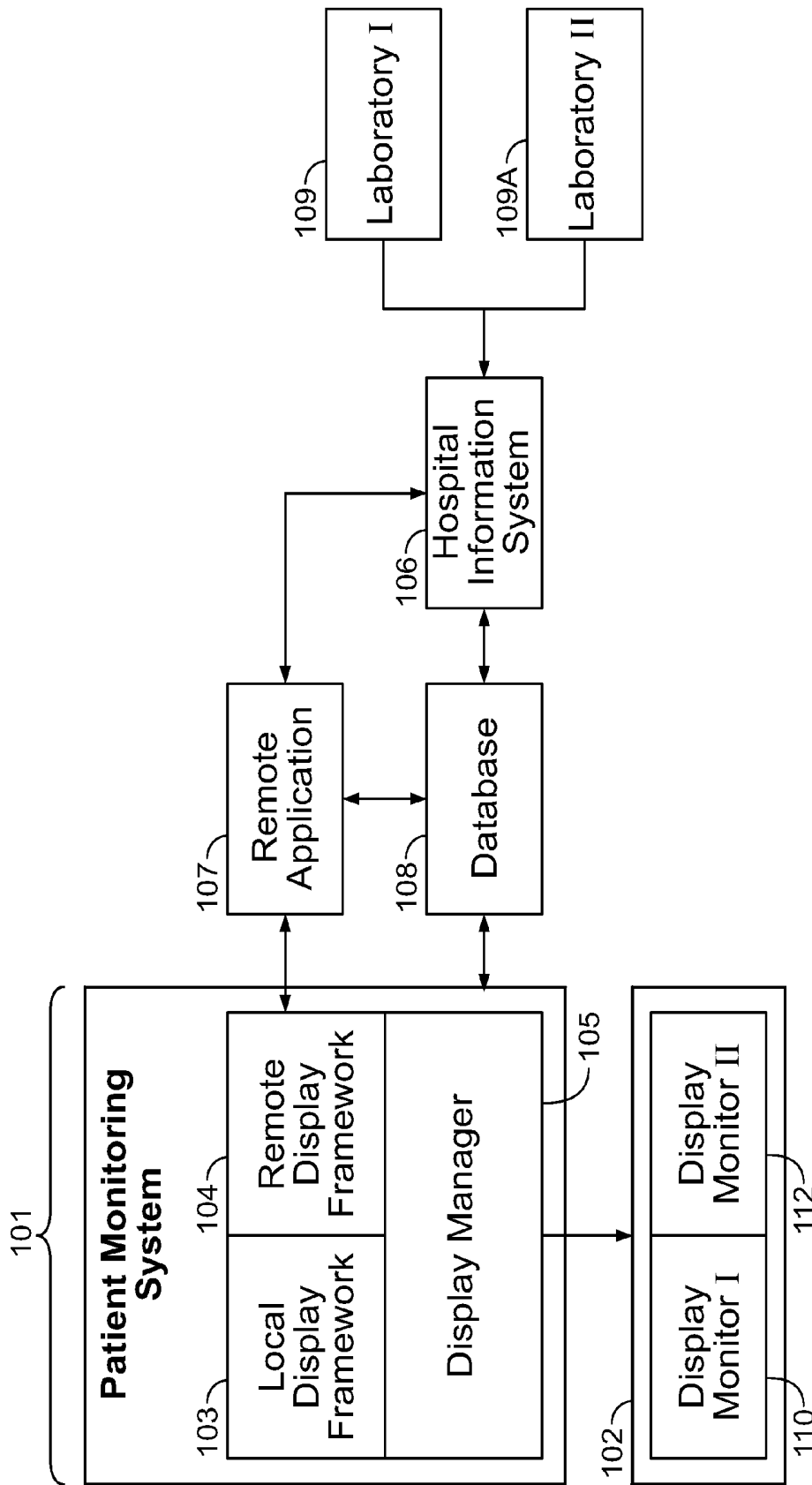

FIG. 1

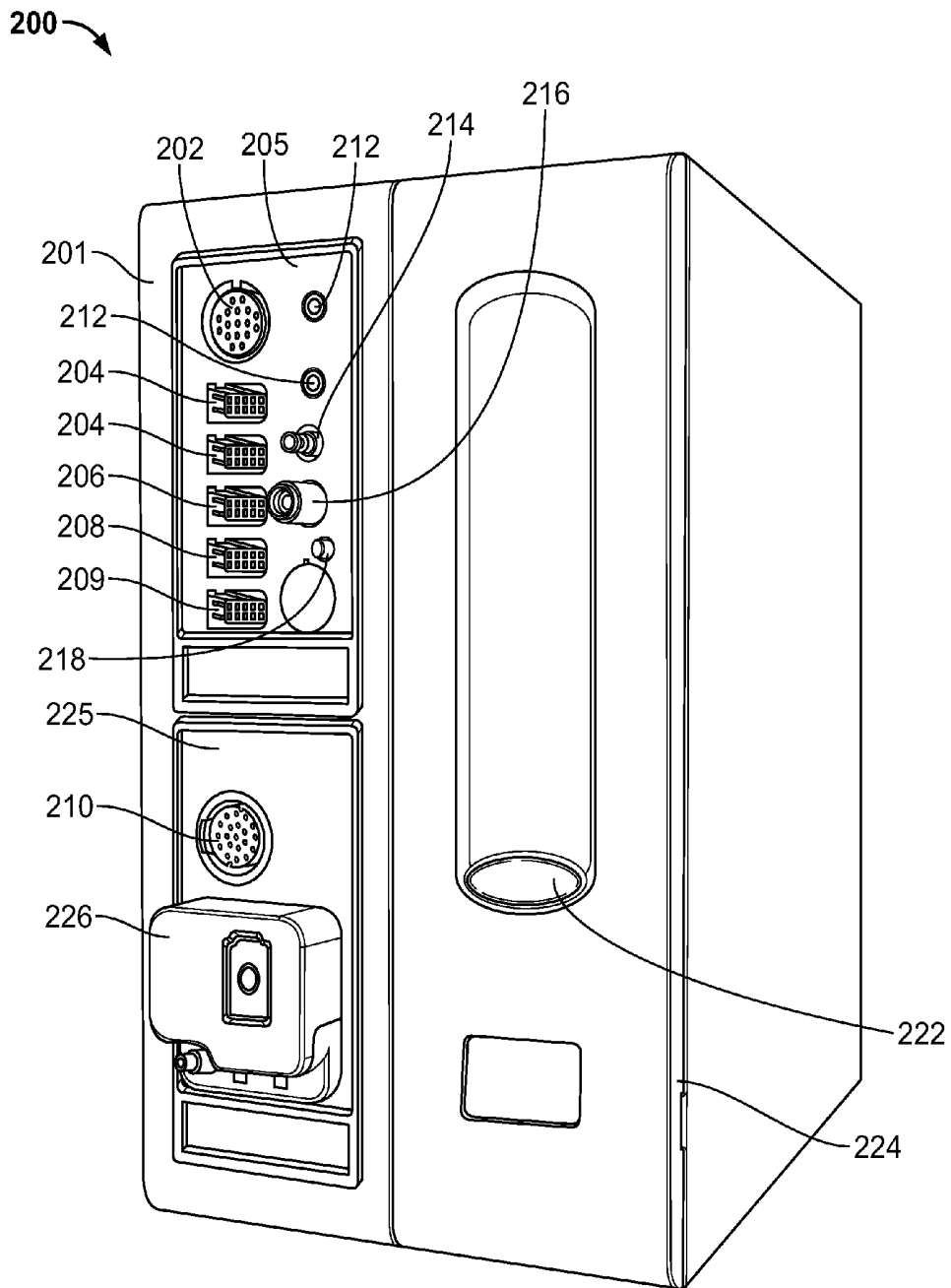

FIG. 2

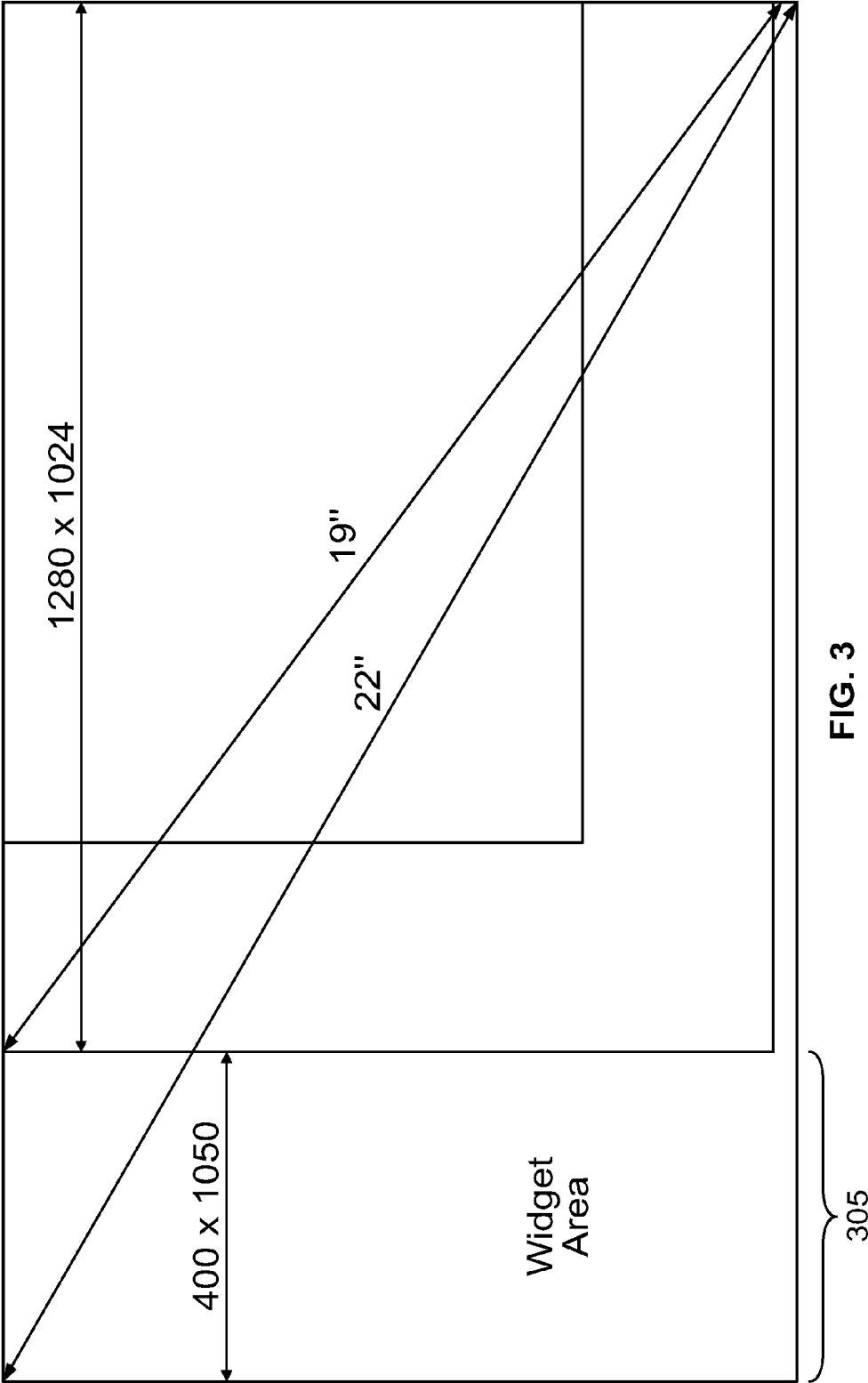

FIG. 3

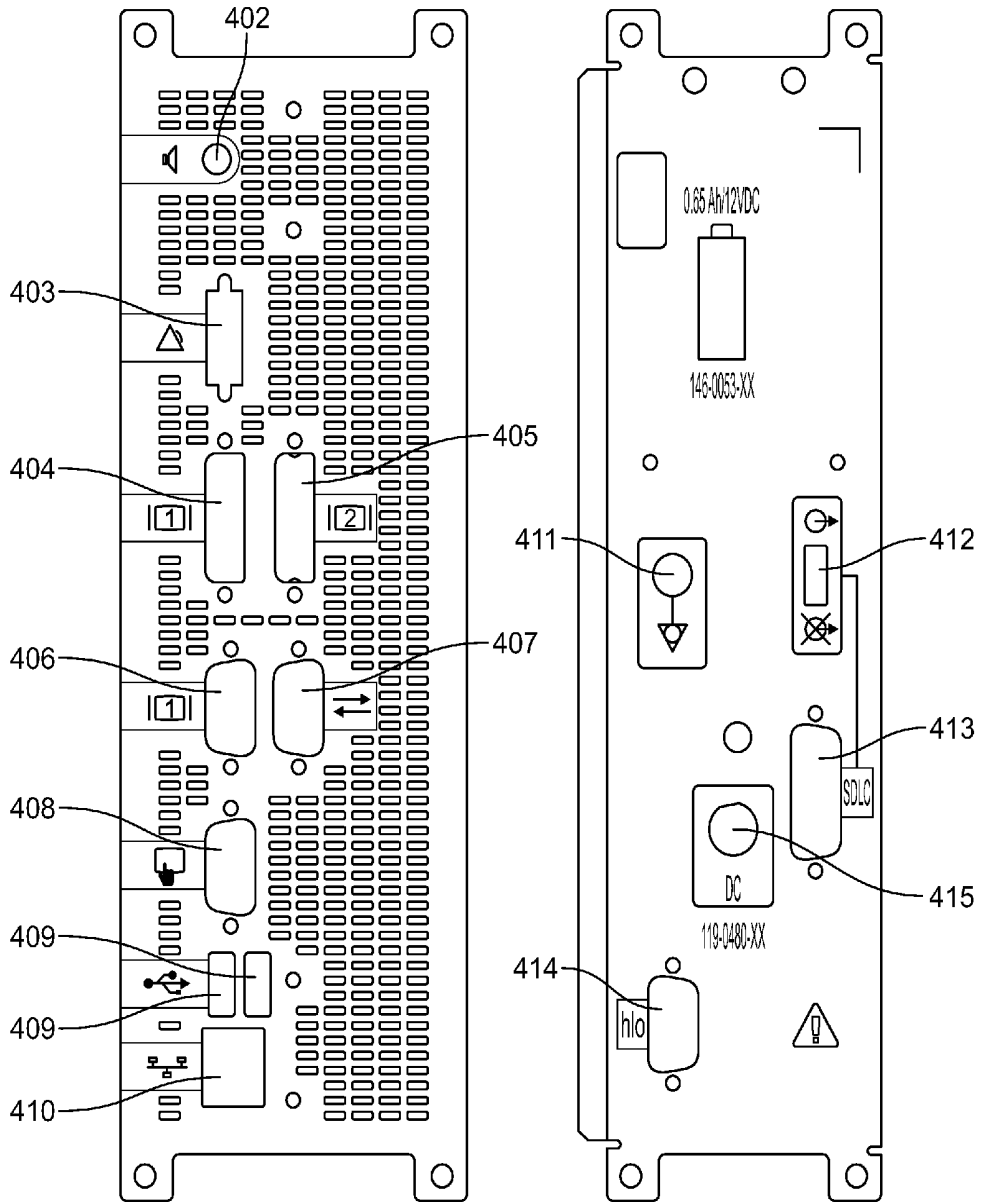

FIG. 4

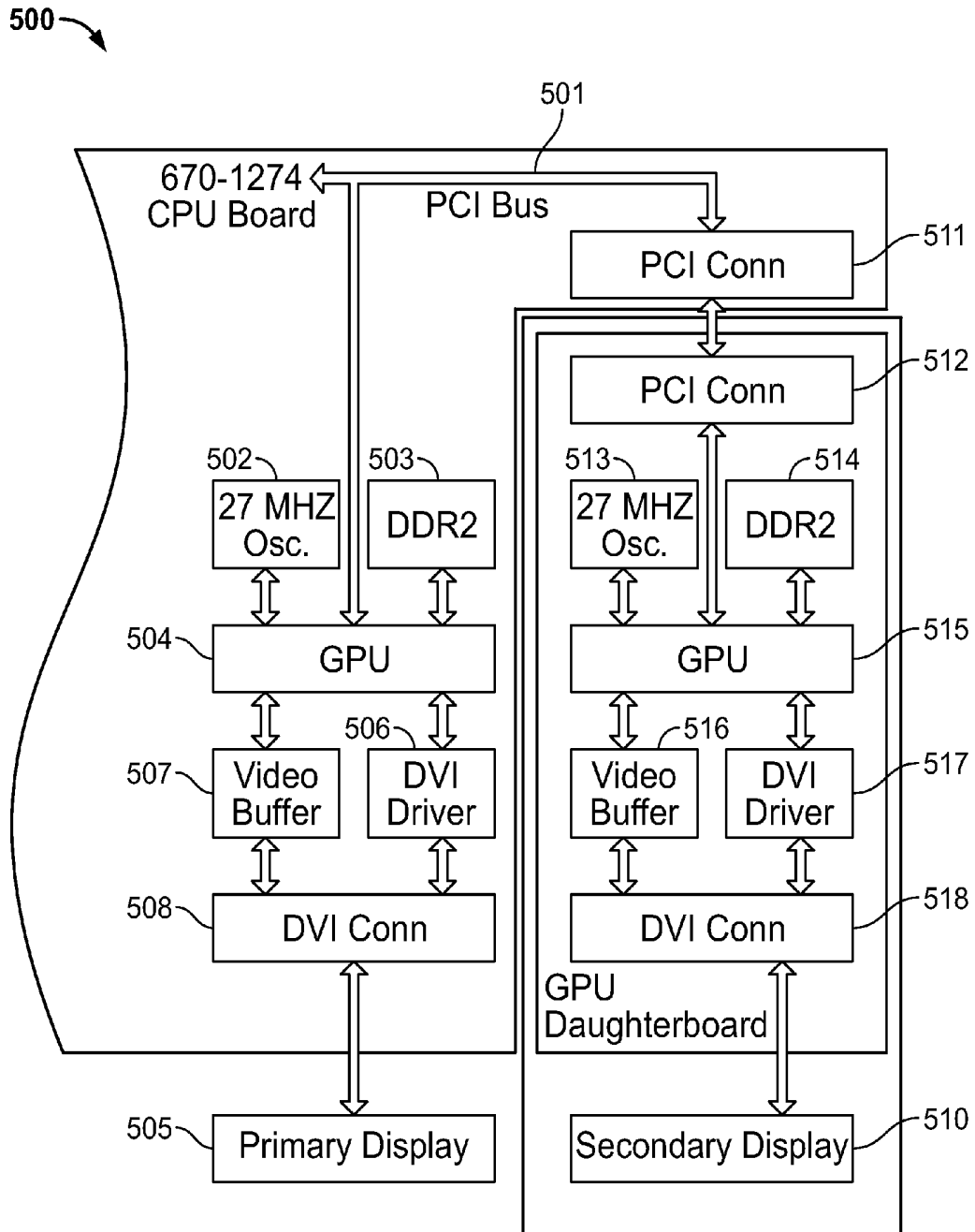

FIG. 5

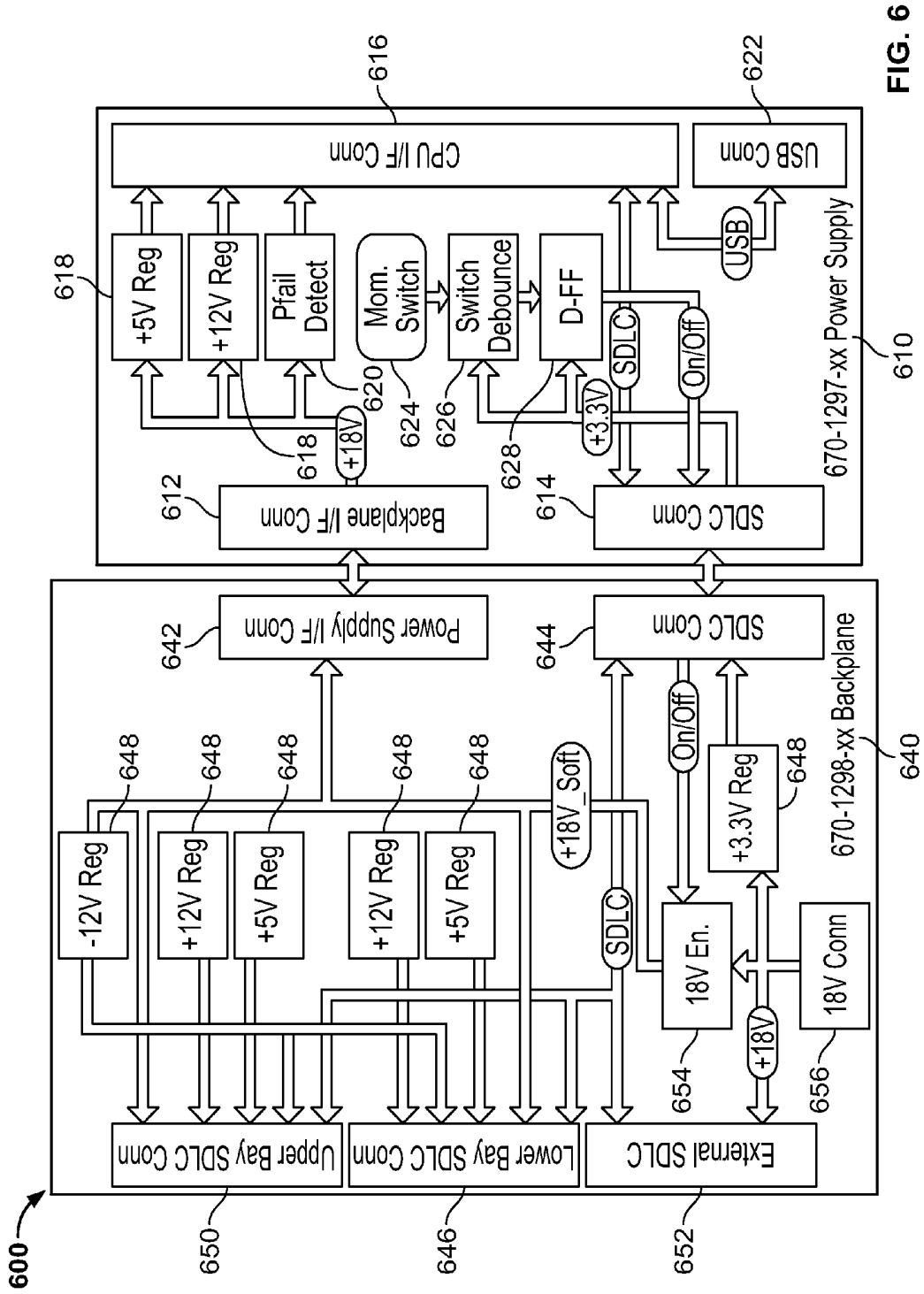
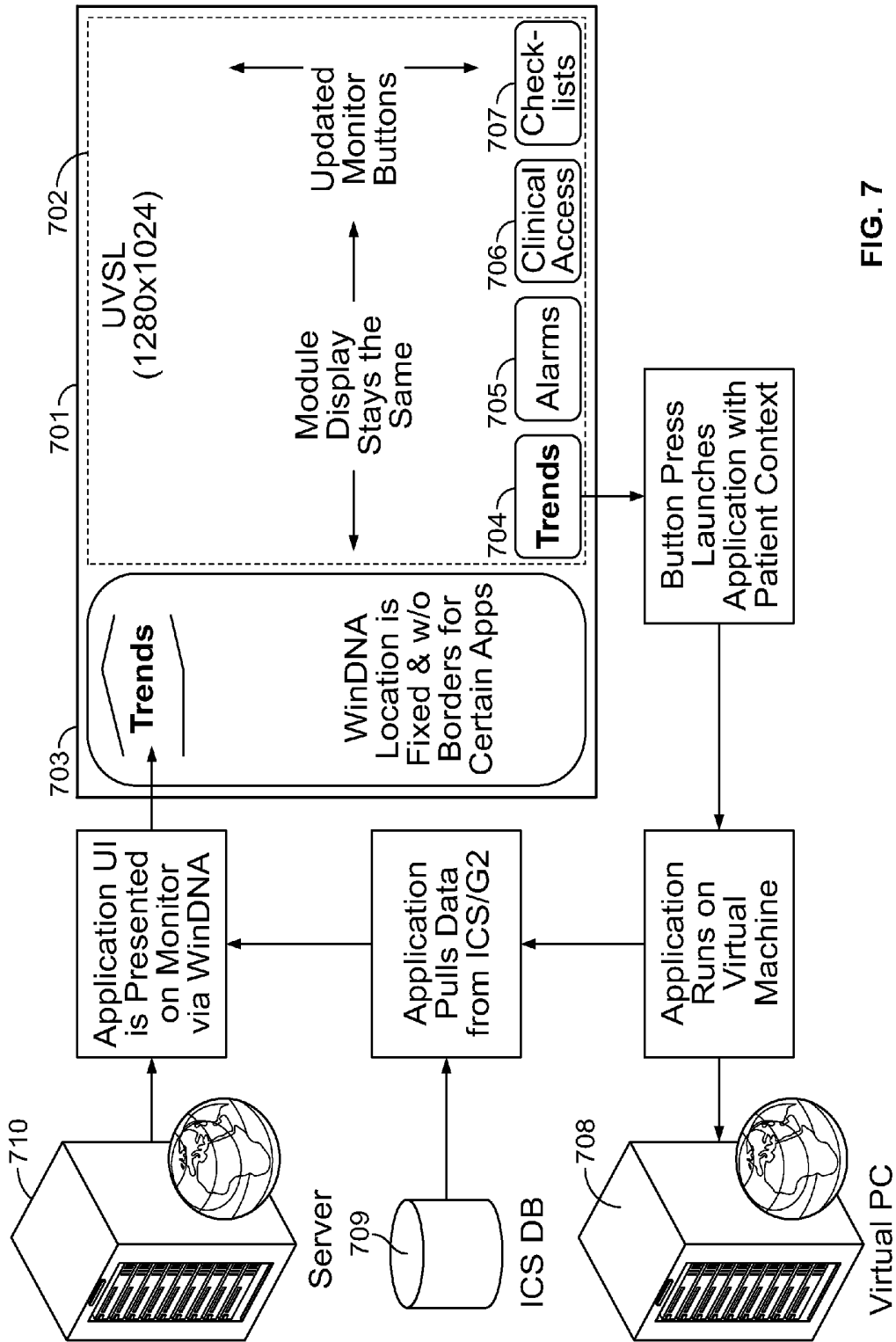

FIG. 6



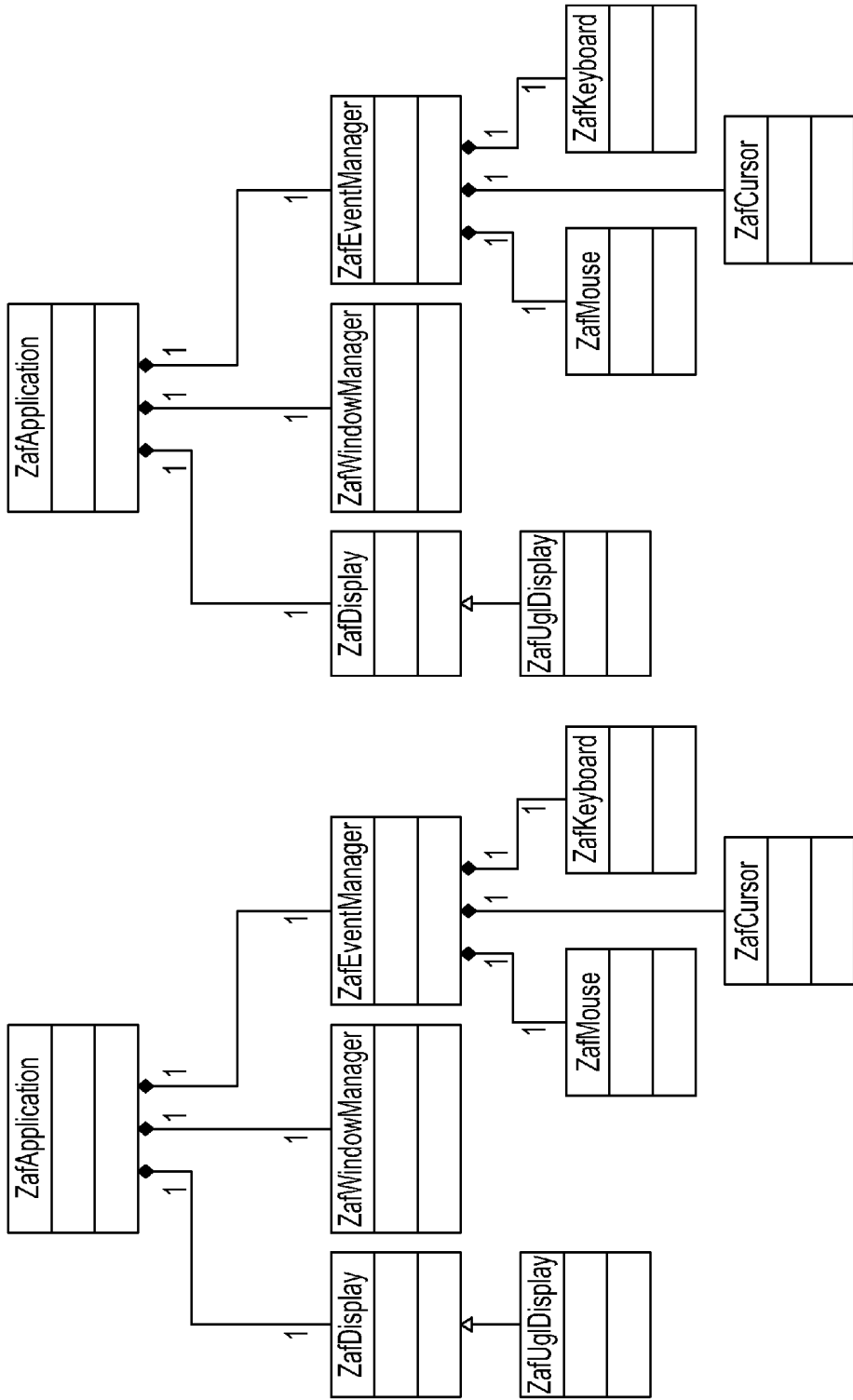

FIG. 8

The Zaf Application Class
will have Multiple
ZafDisplay and Window
Manager Objects that
can Drive Multiple Displays
(1 per Display)

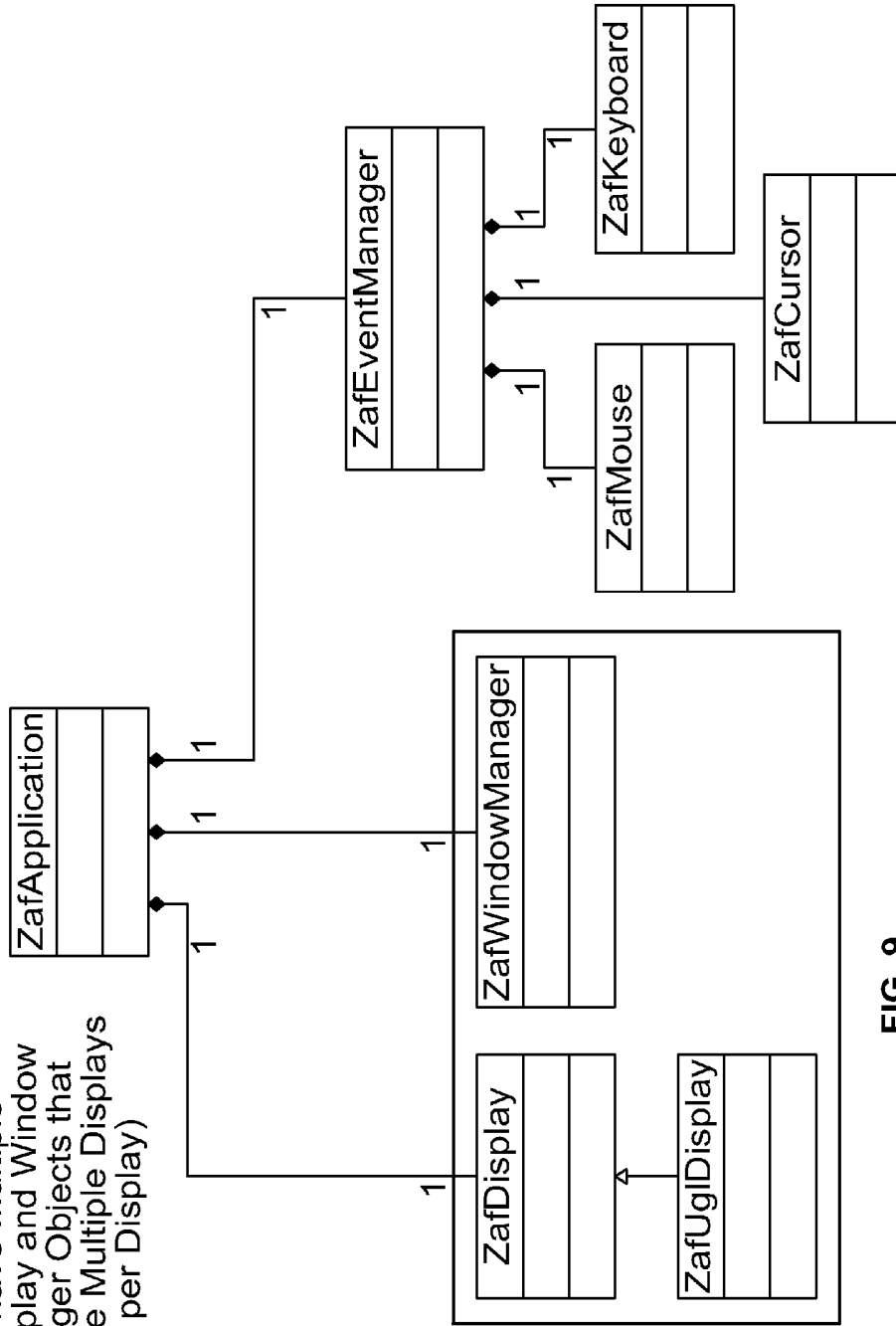

FIG. 9

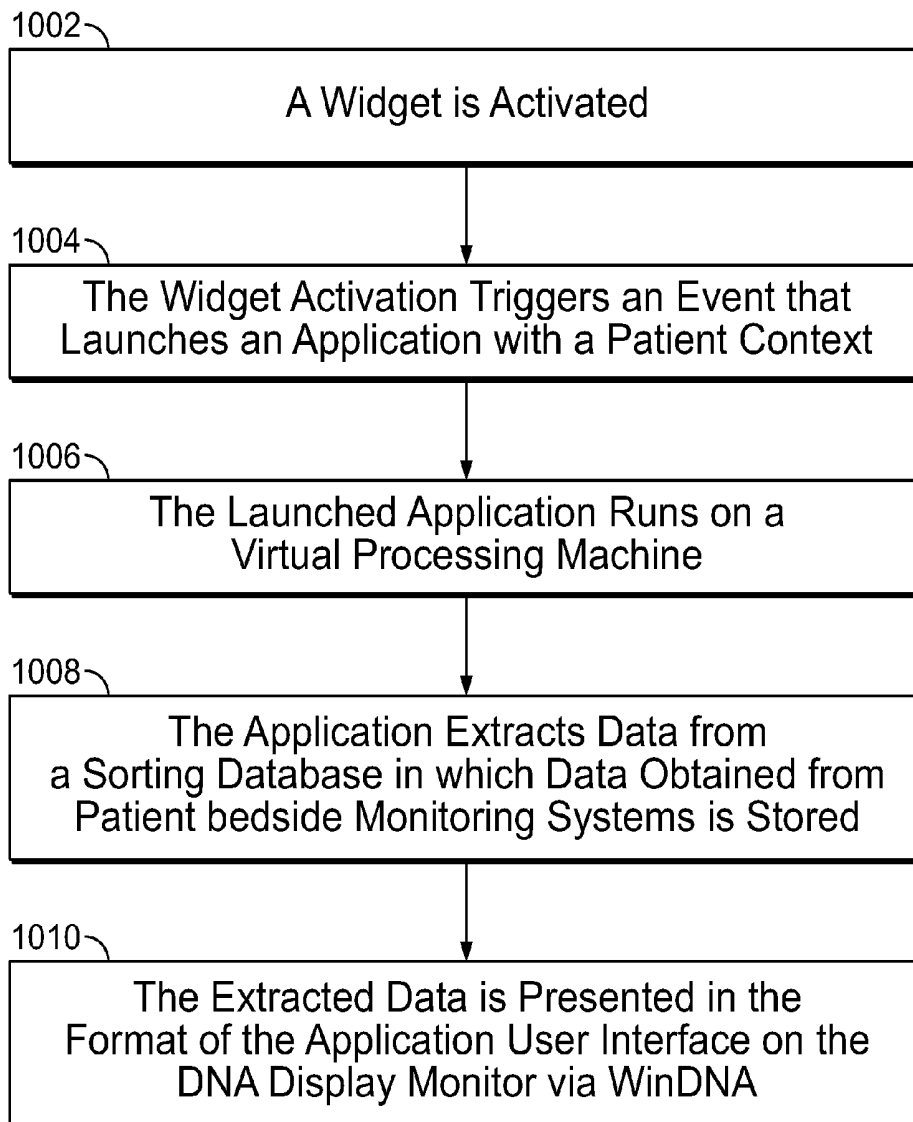

FIG. 10

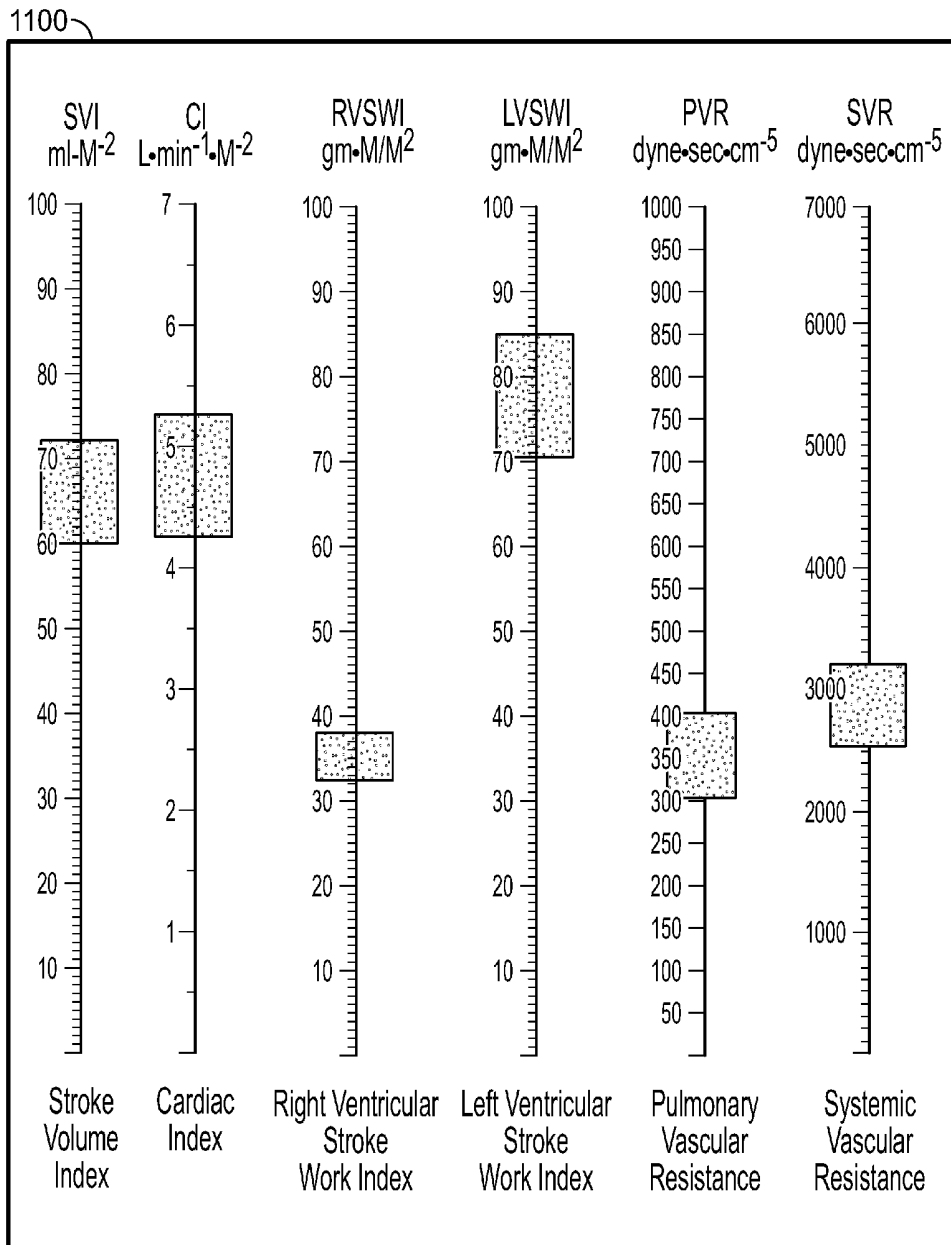

FIG. 11

MULTI-DISPLAY BEDSIDE MONITORING SYSTEM

CROSS-REFERENCE

The present specification is a continuation of U.S. patent application Ser. No. 13/052,883, issued as U.S. Pat. No. 8,674,738, which relies on U.S. Patent Provisional No. 61/315,967, filed on Mar. 21, 2010, for priority and is incorporated herein by reference.

FIELD OF INVENTION

The present specification relates to patient monitoring systems. More particularly, the present specification relates to a system and method of patient monitoring using dual display bedside monitors that are connected to a hospital information system and have the capability to simultaneously display real time patient waveforms and vital statistics as well as provide display for local and remote software applications.

BACKGROUND OF THE INVENTION

Conventional patient bedside monitors are connected to various vital statistics measuring/monitoring devices and display the real time patient vital statistics, such as pulse rate and blood pressure, among other variables, continuously. Usually, the displayed vital statistics are not recorded in the monitor, and hence, once they disappear from a display, the information is not further cached, buffered, or otherwise stored, and therefore lost. In cases where the monitor records displayed information and presents it in the form of patient health trends, the display of real time vital statistics is obscured.

In a hospital environment, patient specific information such as blood test reports and X-ray reports, among other data, are generated at sites remote to the patient bedside. Such information is usually stored in the hospital information system and may be accessed by caregivers as and when required from a central server. The caregivers may be required to carry the information in paper form in order to study/compare it in context with the real time patient vital statistics. As the volume of paper being carried by the caregiver increases, the chances of delay in diagnosis/treatment due to delay in finding a relevant piece of information, increase as well. Also, some piece of patient information may not be available with the caregiver at any given time and may cause a delay or an error in diagnosis and treatment.

Hence, there is need for a patient bedside monitor which is capable of connecting with the hospital information system and displaying all the information related to a specific patient. There is need for a bedside monitor which can display all the patient related information available with the hospital at the same time and without obscuring the real time display of the patient's vital statistics. There is need for a smart bedside monitor that can provide analyses of the patient's health information over a specified period of time corresponding to any pre-defined criteria set by a caregiver.

Furthermore, there is a need for a multi-purpose display that can be partially under a user's control but not supersede or compromise critical functions, such as the display of key monitored physiological parameters or issuance of alarms in relation to monitored events. The multi-purpose display enables a single physical display unit to perform multiple functions, thereby avoiding taking up excessive hospital

room space by additional display units, while not undermining, sacrificing, or compromising the core function of a physiological display.

SUMMARY OF THE INVENTION

The present specification is directed toward a dual display bedside monitor that is connected to a hospital information system and has the capability to simultaneously display real time patient waveforms and vital statistics as well as provide a display for local and remote software applications.

In one embodiment, the present specification is directed toward a system for measuring and displaying a multitude of patient physiological parameters using dual displays at the bedside comprising the following: a patient monitoring system containing various ports for connection of a multitude of physiological parameter measuring devices; a dual display device connected to said patient monitoring system; a database in communication with said patient monitoring system; a hospital information system in communication with said dual display device and said database; and, a plurality of laboratories in communication with said hospital information system.

In one embodiment, the physiological parameter measuring devices include ECG, IBP, NIBP, SpO₂, cardiac output, temperature, capnography, BIS, SvO₂, and EEG measuring devices.

In one embodiment, the dual display device comprises a separate primary display and a separate secondary display. In another embodiment, the dual display device comprises a single display with a first screen area dedicated as a primary display and a second screen area dedicated as a secondary display. In yet another embodiment, the dual display device comprises a separate primary display and a tablet PC that acts as a separate secondary display which connects to the patient bedside monitor.

In various embodiments, the separate primary display, separate secondary display, and single display each measure 19 inches diagonally. In other embodiments, the displays each measure 22 inches diagonally. In another embodiment, the separate primary display measures 19 inches diagonally and the separate secondary display measures 22 inches diagonally. In yet another embodiment, the separate primary display measures 22 inches diagonally and the separate secondary display measures 19 inches diagonally.

In various embodiments, the separate primary display, separate secondary display, and single display each have a screen resolution of 1280×1024 pixels. In another embodiment, the separate primary display has a screen resolution of 1024×768 pixels and separate secondary display has a screen resolution of 1280×1024 pixels.

In one embodiment, the primary display continuously renders measured real time patient waveforms and vital signs and the secondary display renders user specified applications. In another embodiment, both the primary and secondary displays are capable of rendering user specified applications but the primary display is reserved for real time monitoring when an event of significance occurs. In another embodiment, both the primary and secondary displays are capable of rendering real time monitoring information during an event of significance.

In one embodiment, in which there is only a single display, the entirety of the single display is capable of rendering user specified applications. In one embodiment, the user specified applications are minimized during an event of significance, allowing real time monitoring information to be displayed. In another embodiment, a message is displayed on top of the

user specified applications, and said user specified applications are minimized if said message is not acknowledged within a predetermined period of time, allowing real time monitoring information to be displayed. In yet another embodiment, the user specified applications are minimized after a predetermined period of inactivity, allowing real time monitoring information to be displayed. In various embodiments, the predetermined period of time is 1, 3, 5, or 15 minutes.

In one embodiment, an event of significance refers to a plurality of caregiver-predetermined states or scenarios, or occurs whenever a set of values falls outside caregiver-predetermined thresholds or rules. In one embodiment, events of significance are managed by a clinical context manager. In one embodiment, the clinical context manager, based upon the current clinical context, launches local or remote applications.

In one embodiment, the primary display further renders alarm state and technical and medical status information. In one embodiment, the user specified applications rendered by the secondary display comprises information aggregated from said database and said hospital information system. The user specified applications rendered by the secondary display can also comprise local and remote software applications. A plurality of user defined widgets is used to access aggregate data or launch applications. The local and remote software applications can comprise one or more of the following: entertainment software, internet or other network connectivity, patient education software, email applications, and video conferencing applications. In one embodiment, the local software applications are hosted on the dual display bedside monitor. In one embodiment, the remote software applications are hosted on a remote computing device such as a separate bedside monitor, a central workstation, or a physician's office PC.

In one embodiment, the dual display device runs in patient mode when a caregiver is not present and runs in caregiver mode when a caregiver is using the system. Clinical settings are inaccessible while the system is in patient mode. The caregiver has access to clinical settings while the system is in caregiver mode. A caregiver is able to gain access to caregiver mode by entering a credential or password, or by swiping an RFID badge.

In one embodiment, the database comprises at least one storage memory that resides locally within said dual display device and at least one storage memory that resides externally from said dual display device.

In one embodiment, the present specification is directed toward a method for measuring and displaying a multitude of patient physiological parameters using dual displays at the bedside comprising the following steps: measuring a plurality of patient physiological parameters using a multitude of measuring devices attached to a bedside patient monitoring system; transmitting measured data from said patient monitoring system to connected dual display device; displaying real time information on a primary display of said dual display device; additionally transmitting said data from patient monitoring system to a connected database for storing; transmitting some or all of stored data from said database to a hospital information system; transmitting additional patient information gathered from a plurality of laboratories to said hospital information system; and, displaying remote software applications and information aggregated from said database and hospital information system on a secondary display of said dual display device.

In one embodiment, real time patient vital statistics, alarm states, and technical and medical status are continuously dis-

played on said primary display of said dual display device. Some or all of the real time data is concurrently stored on the database. The stored data is transmitted from the database to the hospital information system via standard output formats such as HL7, Medibus. In one embodiment, the stored data is transmitted from the database to the hospital information system at predetermined intervals. In one embodiment, the stored data is accessed via customizable queries to the database.

In another embodiment, the present specification discloses a display system for displaying critical patient data and/or non-critical data, comprising: a plurality of ports configured to connect said display system to a plurality of physiological parameter measuring devices; at least one port configured to connect said display system to at least one network; a display screen comprising a plurality of pixels divided into a first display region and a second display region, wherein said first display region displays data from a first video buffer and wherein said second display region displays data from a second video buffer; and a controller for directing non-critical data to said first video buffer and said second video buffer, wherein, in response to a triggering event, said controller stops directing non-critical data to the first video buffer and directs critical patient data to the first video buffer.

Optionally, the triggering event is at least one of an alarm, a physiological parameter exceeding a predefined threshold, a passage of time, a physiological parameter falling below a predefined threshold, or a detected disconnection of a sensor. In response to the triggering event, the controller automatically stops directing non-critical data to the first video buffer and directs critical patient data to the first video buffer. The detected disconnection of a sensor comprises a disconnected ECG electrode. The physiological parameter falling below a predefined threshold comprises a weakening pulse oximeter signal. The non-critical data comprises laboratory data, prescribed medication, patient educational data, advertising, historical patient health status, historical alarm data, video data, audio data, or email data. The non-critical data is transmitted to the display system, via the at least one network and said at least one port, from a remotely located database. The critical patient data comprises at least one of data a) indicative of a patient's health status requiring immediate attention from a health care provider, b) indicative of a patient's health status which should be brought to the attention of a health care provider but which is not time-critical, or c) designated by a health care provider as requiring substantially constant display. The physiological parameter measuring devices comprise ECG, blood pressure, SpO₂, cardiac output, temperature, capnography, BIS, SvO₂, or EEG measuring devices.

In another embodiment, the present specification discloses a display system for displaying critical patient data and non-critical data, comprising: a plurality of ports configured to connect said display system to a plurality of physiological parameter measuring devices; at least one port configured to connect said display system to at least one network; a display screen comprising a plurality of pixels divided into a first display region, having a first pixel count, and a second display region, having a second pixel count, wherein said first display region displays data from a first video buffer and wherein said second display region displays data from a second video buffer; and a controller for directing non-critical data to said first video buffer and for directing critical patient data to said second video buffer, wherein, in response to a triggering event, said controller decreases the first pixel count, thereby decreasing the first display region size, and increases said second pixel count, thereby increasing said second display region size.

Optionally, the triggering event is at least one of an alarm, a physiological parameter exceeding a predefined threshold, a passage of time, a physiological parameter falling below a predefined threshold, or a detected disconnection of a sensor. In response to the triggering event, the controller automatically stops directing non-critical data to the first video buffer and directs critical patient data to the first video buffer. The detected disconnection of a sensor comprises a disconnected ECG electrode. The physiological parameter falling below a predefined threshold comprises a weakening pulse oximeter signal. The non-critical data comprises laboratory data, prescribed medication, patient educational data, advertising, historical patient health status, historical alarm data, video data, audio data, or email data. The non-critical data is transmitted to the display system, via the at least one network and said at least one port, from a remotely located database. The critical patient data comprises at least one of data a) indicative of a patient's health status requiring immediate attention from a health care provider, b) indicative of a patient's health status which should be brought to the attention of a health care provider but which is not time-critical, or c) designated by a health care provider as requiring substantially constant display. The physiological parameter measuring devices comprise ECG, blood pressure, SpO₂, cardiac output, temperature, capnography, BIS, SvO₂, or EEG measuring devices. The critical patient data comprises a predefined set of values generated in real-time from said physiological parameter measuring devices.

In another embodiment, the present specification discloses a method for concurrently displaying non-critical data and a multitude of patient physiological parameters being monitored in real-time on a display screen, having a plurality of pixels divided into a first display region with a first pixel count and a second display region with a second pixel count, comprising: receiving monitored data from a plurality of patient physiological parameters; receiving stored data from at least one data network; buffering critical patient data in a first video buffer; buffering non-critical data in a second video buffer; displaying critical patient data in said first display region, wherein said first display region is in data communication with said first video buffer and not said second video buffer; displaying non-critical data in said second display region, wherein said second display region is in data communication with said second video buffer and not said first video buffer; and in response to a triggering event, decreasing the first pixel count, thereby decreasing the first display region size, and increasing said second pixel count, thereby increasing said second display region size.

Optionally, the triggering event is at least one of an alarm, a physiological parameter exceeding a predefined threshold, a passage of time, a physiological parameter falling below a predefined threshold, or a detected disconnection of a sensor. The non-critical data comprises laboratory data, prescribed medication, patient educational data, advertising, historical patient health status, historical alarm data, video data, audio data, or email data. The critical patient data comprises at least one of data a) indicative of a patient's health status requiring immediate attention from a health care provider, b) indicative of a patient's health status which should be brought to the attention of a health care provider but which is not time-critical, or c) designated by a health care provider as requiring substantially constant display.

The aforementioned and other embodiments of the present invention shall be described in greater depth in the drawings and detailed description provided below.

BRIEF DESCRIPTION OF THE DRAWINGS

These and other features and advantages of the present specification will be further appreciated, as they become bet-

ter understood by reference to the detailed description when considered in connection with the accompanying drawings:

FIG. 1 is a block diagram illustrating an environment in which the dual display monitor is used, in accordance with an embodiment of the present invention;

FIG. 2 illustrates a patient monitoring system, as shown in FIG. 1, that is employed, in one embodiment, to support and/or control dual display functionality;

FIG. 3 is a block diagram illustrating screen size and usage differences of the dual display monitor among multiple embodiments of the present invention;

FIG. 4 illustrates the rear panel of a patient monitoring system that is employed, in one embodiment, to support and/or control dual display functionality;

FIG. 5 illustrates a block diagram of the video configuration of the dual display monitor, in accordance with an embodiment of the present invention;

FIG. 6 illustrates a block diagram of the power configuration of the patient monitoring system that is employed, in one embodiment, to support and/or control dual display functionality;

FIG. 7 illustrates a block diagram of the data access and display architecture of one embodiment of the present invention;

FIG. 8 illustrates an architectural block diagram of the dual display monitors, in accordance with an embodiment of the present invention;

FIG. 9 illustrates an architectural block diagram of the dual display monitors, in accordance with another embodiment of the present invention;

FIG. 10 is a flowchart illustrating the events that take place upon activation of a widget on a display monitor, in accordance with an embodiment of the present invention; and

FIG. 11 illustrates a plot of hemodynamic indices displayed on a display monitor, in accordance with an embodiment of the present invention.

DETAILED DESCRIPTION OF THE INVENTION

The present specification provides a dual display monitor which can be set up at a patient bedside to provide aggregated medical information related to the patient along with the patient's real time vital statistics. One of the two displays continuously shows the real time patient monitoring information whereas the other is used to display information such as when medicines were delivered, show lab results in reference to vital signs, and provide access to other remote hospital applications, typically only accessible via separate data terminals. The dual display monitor is connected to the hospital information system and has the capability of displaying local software applications and remote software applications via remote display software, such as, software made available by Citrix™. In addition, the dual display monitor can be connected to a central monitor configuration that can include up to four additional displays. These additional displays can be used to monitor more patients, display additional data, and/or host other applications.

The present specification is directed towards multiple embodiments. The following disclosure is provided in order to enable a person having ordinary skill in the art to practice the invention. Language used in this specification should not be interpreted as a general disavowal of any one specific embodiment or used to limit the claims beyond the meaning of the terms used therein. The general principles defined herein may be applied to other embodiments and applications without departing from the spirit and scope of the invention. Also, the terminology and phraseology used is for the purpose

of describing exemplary embodiments and should not be considered limiting. Thus, the present specification is to be accorded the widest scope encompassing numerous alternatives, modifications and equivalents consistent with the principles and features disclosed. For purpose of clarity, details relating to technical material that is known in the technical fields related to the invention have not been described in detail so as not to unnecessarily obscure the present invention.

FIG. 1 is a block diagram illustrating an environment in which the dual display monitor is used in accordance with one embodiment of the present invention. The dual display monitor 102, comprising a first display monitor 110 and a second display monitor 112, is installed by a patient's bedside and is connected to the patient monitoring system 101 through a display manager 105 included within said patient monitoring system 101. In various embodiments, the patient monitoring system 101 includes ports for a plurality of measuring devices, which includes but is not limited to, ports for blood pressure monitoring systems, heart rate monitoring systems, and pulse oximeter monitoring systems. The display manager 105 interfaces with a local display framework 103 and a remote display framework 104, both of which are also included within the patient monitoring system 101. The remote display framework 104 communicates with a remote application 107 which in turn collects information from a database 108 and a hospital information system (HIS) 106. The HIS 106 has access to data received from a plurality of laboratories 109, 109A. Data received from the laboratories 109, 109A comprises blood test reports, X-ray scan reports, among other data. The patient monitoring system 101 also interfaces directly with said database 108 and in turn, the HIS 106.

Patient monitoring information is fed to database 108 where the information is sorted and, in one embodiment, a subset of the information is fed to the hospital information system 106. First display monitor 110 displays real time patient vital statistics as obtained from the patient monitoring system 101. Real time patient statistics comprise, for example, numeric data (such as heart rate, systolic blood pressure, and cardiac output), alarm states (when a patient's current status violates a preconfigured alarm state) and other technical and medical status (such as anomalistic weakening of pulse oximeter signal or disconnection of ECG electrode(s)).

Database 108 comprises at least one storage memory that resides locally within the dual display monitor 102 as well as at least one storage memory external to the monitor 102 residing in proximity or remotely from the monitor 102. Thus, in one embodiment, some or all of the patient vital statistics data, communicated and displayed real-time by first display monitor 110, is also stored in local data storage residing within the dual display monitor 102. This locally stored patient data, in one embodiment, is used to create trend displays and to allow review of alarm data in clinical context. In one embodiment, at least a portion of the entire patient vital statistics data stored in local data storage residing within the dual display monitor is also available for posting to the hospital information system. Additionally or in alternate embodiments, some or all of the patient vital statistics data is communicated over a network for storage in a database that is external to the dual display monitor 102. The storage capacity of such an external database is typically large to accumulate data over a long period of time. Persons of ordinary skill in the art should appreciate that the external database may reside on a computer/server in proximity to the dual display monitor 102 and/or on a computer/server remote from the dual display monitor 102.

Data from the external database is exported to the hospital information system 106 using standard output formats such as HL7, Medibus. In one embodiment, data from the external database is pushed out to the hospital information system 106 at predetermined intervals. Additionally, the data is also accessible via queries to the external database, which in one embodiment, may be customized.

Second display monitor 112 displays information aggregated from the database 108 and the hospital information system 106. Information such as the patient's health trends, drug effects on the patient's vital statistics, lab results, among other data, are displayed on the second display monitor 112, provided by at least one or more underlying local or remote software programs. Hence, the information displayed on the second display monitor 112 enables caregivers to understand and analyze the patient's progress and response to drugs and hence, effectively respond to changes in the patient.

In one embodiment, local and remote software applications accessed on the dual display monitor 102 enable viewing of patient data stored in the external database in a way that enhances monitoring functionality at the patient bedside. For example, an ECG waveform review application, hosted on the monitor 102, allows waveform records over the last 72 hours to be reviewed, edited, forwarded and re-stored. In another example, a database application enables retrieval of readings from laboratories 109 and trends them for display. Persons of ordinary skill in the art should appreciate that such software applications may reside locally or be hosted on a separate bedside monitor, a central workstation or at a physician's office PC. In each case the patient data is retrieved from the external database and the editing session is run on the appropriately connected computer. Additionally, in further embodiments, the local and remote software applications accessed on the dual display monitor 102 also comprise applications other than those just related to providing patient monitoring functionality. For example, such software could be an entertainment; Internet or other network connectivity; or a patient education application or an email or video conferencing application or any other value-added application that would be advantageously evident to those of ordinary skill in the art. In one embodiment, fixed screen zones are established for patient applications. For example, patients are not allowed to cover up vital signs displays or they are restricted to using the second display monitor 112, in one embodiment, for email, video conference, or other patient activities.

In one embodiment, the dual display monitor 102 can be enabled in either patient mode or caregiver mode. In patient mode clinical settings cannot be changed but a controlled list of approved software applications, such as entertainment or patient education, can be run. The monitor is in patient mode unless a caregiver is in the room. Thus, for example, when the patient is in the room unattended the monitor would typically be in patient mode. The mode can be changed remotely by a caregiver. To change into caregiver mode the monitor is enabled to take a credential, password or RFID badge. In one embodiment, context sensitive disabling or minimization of patient mode is enabled. Thus, in the event of a change in clinical state [for example a certain alarm class (high priority)] the patient's application is disabled or minimized until cleared by a caregiver. Ideally, this would be configurable by the caregiver by alarm type or alarm class.

The dual display functionality of the monitor 102 of the present invention enables optimization between the display of real-time patient monitoring data and therefore related alarm contexts and the display of information from local or remote software applications accessed on the monitor 102.

Optimization is achieved by providing adequate screen real estate through a plurality of scenarios, such as, in the following various embodiments, wherein in a first embodiment, first display 110 is used for full time real-time monitoring while second display 112 is used for full time hosted application viewing. In another embodiment, first display 110 and second display 112 are both available for hosted application viewing but first display 110 is reserved for real-time monitoring when an “event of significance” occurs. In yet another embodiment, first display 110 and second display 112 are both available for monitoring during an “event of significance”.

It should be appreciated that the presently disclosed system enables critical patient data, defined as data which a) is indicative of a patient health status requiring immediate attention from a health care provider or that is otherwise time-critical, b) is indicative of a patient health status which should be brought to the attention of a health care provider but which may not be time-critical, and/or c) is designated by a health care provider as requiring substantially constant display, to be displayed alongside non-critical data, defined as data which does not constitute critical patient data, without compromising the display of the critical patient data. It should further be appreciated that the functionality described herein is effectuated by a controller implementing a plurality of instructions, stored in memory local or remote from the display, and executed by at least one processor.

In another embodiment, there is only one display but a portion is pre-allocated as application display area. In another embodiment, there are two, three, four, or more separately controlled display regions in a single physical display. In another embodiment, there are two, three, four, or more separately controlled display regions in two or more physical displays. It should be appreciated that a display area or region can be a region of pixels located in one or more physical displays.

In yet another embodiment, there is only one display and applications can take all of the screen area but surrender control during an “event of significance”. In this case, it is possible that a caregiver is running a software application and hiding/covering some or all of the monitor’s real-time vital information when a patient’s status changes. In such cases, in one embodiment, the monitor is enabled to minimize all applications for certain types of patient events. Thus, certain events (alarms of a certain type or priority) automatically minimize all applications thus displaying the monitoring message. In another embodiment, the application is left running but a message (which must be responded to) is posted on top of any and all applications. If the message is not responded to, then the application is automatically minimized. Still alternatively, all applications could be minimized automatically after a configurable time out. Thus, in the event an application user leaves the application running (covering some or all of the real-time vitals monitoring functionality), the application is minimized after a period of no-activity. In various embodiments, the period of inactivity is set to 1, 3, 5, 15, or any other user determined value. For example, assuming a 3 minute inactivity threshold, if a user accesses an application and enters data for 5 minutes, the application will not minimize because of the activity. When the user is called away from the monitor, after 3 minutes the application will be minimized automatically.

Persons of ordinary skill in the art should appreciate that an “event of significance” could be a plurality of predefined states/scenarios/thresholds/rules. In one embodiment, an “event of significance” is user defined (such as, for example, Heart rate > 140 bpm, Systolic blood pressure > 150 or < 90). In another embodiment, an “event of significance” is defined by

an arbitrarily complex set of rules to define when non-critical applications should surrender to the real-time monitor. In yet another embodiment, the “event of significance” is based on alarm status (such as: any alarm, any high priority alarm, and any medium or higher priority alarm). In still yet another embodiment, the “event of significance” is capable of being overruled by a user. Thus, a user may override and run an application by deciding that an alarm is actually not real.

In one embodiment, “events of significance” related functions are managed by a software module, hereinafter referred to as the ‘clinical context manager’. The clinical context manager monitors the patient state and continuously compares it to the rules that have been established (defaults or user defined). Accordingly, the context manager signals hosted software applications to be displayed or minimized.

Further, based on the patient’s state, the context manager can trigger additional activities, which may be default behaviors or they may be configured by the user. They may be configured based on alarm type or severity, or they may be based on clinical indexes that are currently being monitored. The additional activities that are triggered may be of several different types, such as, but not limited to, the following:

- a) logging additional data into the local or external database
- b) launching an application that retrieves additional information from a local or external database and presents the current state in a clinical context in the application area.
 1. For example, where a patient’s blood pressure is dropping gradually, the patient’s change in state is noted by the clinical context manager and an application is launched that retrieves the complete blood pressure history and plots the recent change in context to the historical record. This data is displayed in the application window.
 2. Where a patient is a diabetic, a user may select a default clinical context of diabetes for this patient (or it may be selected automatically if the diabetes diagnosis was retrieved from a health record). These activities are user configurable. Part of the “diabetes” clinical context default rules may be to retrieve most recent blood sugar reading in the event of successive low pressure readings. In this case, multiple low readings would trigger an application to retrieve the extended blood pressure history and the extended laboratory and blood draw data and present this data in an application window. A clinician who then checked on the patient would see the current monitoring status and the relevant data presented in a clinically appropriate manner.
 3. In another example, the primary display is displaying ECG, SpO2 and NIBP values for a patient. Initially, the patient is in normal sinus rhythm but over time begins to develop an increasing number of abnormally conducted beats. The clinical context manager launches a trending application (either locally on the monitor or on a remote workstation) that renders a trend graph of the number of abnormal beats versus time for the last few hours. This trend will draw the attention of the caregiver to a parameter that the clinical context manager has determined is changing.
 4. In yet another example, the clinical context manager will launch a trending application if a patient’s mean heart rate increases by more than 15%. In this example, the trending application will display the patient’s heart rate for the last 6 hours and render the data at 30 second resolution with updates in real time.

FIG. 2 illustrates a patient monitoring system, as shown in FIG. 1, that is employed, in one embodiment, to support and/or control dual display functionality; The patient monitoring system 200 supports the connection of two display units such as video display units (VDU), liquid crystal display (LCD) screen, among any other display type known in the art. The patient monitoring system 200, which in one embodiment comprises first module 205 and second module 225, is provided with a plurality of ports on a panel 201 for enabling connection with display units, a hospital database, and other networks.

First module 205 comprises a plurality of ports that provide interfaces to patient connected cables, transducers or sensors. In one embodiment, port 202 is the connector for an ECG cable. This cable is connected to the electrodes on the patient and ECG analysis is performed by the patient monitor.

In one embodiment, port 204 is a connector for an Invasive Pressure cable. This cable is connected to a catheter placed inside the patient.

In one embodiment, port 206 is a connector for connecting an appropriate SpO₂ cable. The cable is connected to a SpO₂ sensor and attached to the patient. The pulse oximeter function is inside the patient monitor.

In one embodiment, port 208 is a connector for a cardiac output cable, which would attach to a catheter put into the patient. The cardiac output analysis is performed by the patient monitor.

In one embodiment, port 209 is a connector for a dual temperature cable. The temperature analysis is performed by the patient monitor.

In one embodiment, port 212 is a high level output designed to provide an external analog interface to an ECG or Invasive pressure waveform.

In one embodiment, port 214 is a connector to an adult NIBP adapter hose.

In one embodiment, port 216 is a connector to a neonatal NIBP adapter hose.

In one embodiment, button 218 is provided to enable a "Stop" NIBP control.

In one embodiment, ports 210 and 226 of second module 225 are related to a capnography gas analyzer. Port 210 is a connector which attaches to the patient for mainstream capnography. Port 226 is a connector for side stream capnography. The second module 225 could be used for any of a number of different specialty monitoring applications such as BIS (bispectral index), SVO₂ or EEG, as manufactured by Spacelabs Healthcare LLC.

Persons of ordinary skill in the art should appreciate that the patient monitoring system 200 of the present invention allows appropriate interfaces for connectivity to additional and/or alternate medical/patient monitoring devices that are manufactured by third party vendors. For this purpose, a plurality of connections or ports may be provided a panel of the patient monitoring system 200, hereinafter referred to as flexports or data interfaces, to third party devices or networks. For example, there could be a case where a particular respirator or a pulse oximeter made by a third party vendor/manufacturer needs to be used. For devices which use the flexport interface, the data is then displayed on the patient monitoring system 200 (such as in the form of waveforms, numeric data, indices and/or alarms) and can be trended and reviewed along with the other data. Data from these flexport devices can also be exported to an external database (as described with reference to database 108 of FIG. 1). Similarly, connections to a network and connections to the two video outputs for the display monitors can be found on the back panel.

In one embodiment, and as mentioned with respect to FIG. 1, the dual display monitor 200 supports a first display unit and a second display unit, which in one embodiment are 19 inches with a 4x3 ratio, and wherein the resolution of real-time patient monitoring display is 1024x768 and that of software application display is 1280x1024 pixels. In another embodiment, the two display units measure 22 inches diagonally and have a 16x9 (wide aspect) ratio. FIG. 3 is a block diagram illustrating screen size and usage differences of the dual display monitor among multiple embodiments of the present invention. In one embodiment, in which both display units measure 22 inches, both display units have a resolution of 1280x1024 pixels. In one embodiment, in which both display units measure 22 inches, the vertical screen height of both monitors is approximately the same as that of the 19 inch display units, and the extra horizontal screen space 305 is reserved for widgets. In one embodiment, the vertical screen height of the 22 inch display units differs from that of the 19 inch display units by +/-0.2 inches. In an embodiment, a single mouse control and a single keyboard control is provided as input devices for both the displays. Input may also be provided via 'touch screen' functionality provided to the two displays.

In an embodiment, the application display presents remote or virtual applications. In various embodiments, there are a number of controls that allow caregivers to decide how they want to see the information. In an embodiment, caregivers may preset the application display screen. For example, if all cardiologists want to see the same data, the application display screen may be preset to a standard cardiology data display. A caregiver may choose an option entitled 'cardiology' and obtain all cardiology related information available with the hospital information system with or without any specific patient context. In an embodiment options presented on the monitor screen may be selected by using voice recognition technology based on radio frequency identification (RFID).

In various embodiments the application display screen is a multi-purpose device/monitor that may be used as a high definition television (HDTV), as a user interface for sending emails, as an interface for patient education, as a user interface for running bedside applications (patient entered data such as pain score), as a screen for playing video games, for conducting mental acuity tests, among other optional activities. In an embodiment, the application display can be a tablet PC that is provided to a clinician that connects to patient bedside monitor. Thus, the second display may not be on the monitor 200, but may be provided remotely to the caregiver.

Referring again to FIG. 2, a power switch 222 is provided on a panel for turning the dual display monitor 200 on or off. In one embodiment, the power switch 222 is secured to the power supply board by elastomer prongs and is positioned between the power supply board and a panel bezel. The power switch 222 is back lit for enabling easy viewing of the monitor's power status. An extra universal serial bus (USB) port 224 is provided on a side of the front panel 201 for connecting any ancillary monitoring device or a supported USB accessory.

FIG. 4 illustrates the rear panel of a patient monitoring system that is employed, in one embodiment, to support and/or control dual display functionality. As discussed above, a panel of the patient monitoring system may contain a plurality of flexports or data interfaces for connectivity to additional and/or alternate third party patient monitoring devices. In one embodiment, a panel includes an audio output port 402 and an alarm relay output port 403. The panel also includes a first DVI video output port 404 and a second DVI video output port 405 for a second independent display. A VGA video

output port **406** is also included for connecting a display. The panel additionally includes serial port **407** and another serial port **408** for an external touchscreen. Two USB-A ports **409** and an Ethernet port **410** are also included. The panel includes an equipotential terminal **411**, SDLC terminator switch **412**, SDLC/Power output **413**, and high level analog output **414**. In addition, the panel contains a DC power input port **415** for connection of a power cable to the patient monitoring system.

FIG. 5 illustrates a block diagram of the video configuration of the dual display monitor **500**, in accordance with an embodiment of the present invention. A PCI data bus **501** carries data transmitted from a processor to one of two displays, a primary display **505** and a secondary display **510**. With respect to the primary display **505**, the PCI data bus **501** interfaces with a processing unit **504** which is in data communication with oscillator **502** and memory **503**. The processing unit **504** processes data for display and transmits it to a video buffer **507** and display driver **506**. Display data is then interfaced to the primary display **505** via an interface **508**.

Similarly, with respect to the secondary display **510**, the PCI data bus **501** interfaces with a PCI interface unit **511**, which interfaces with PCI interface unit **512** and communicates with processing unit **515**, which is in data communication with an oscillator **513** and memory **514**. The processing unit **515** processes data for display and transmits it to a video buffer **516** and display driver **517**. Display data is then interfaced to the primary display **510** via an interface **518**.

The architecture of the Dual Display system enables improved data access and an integrated display of data from multiple sources. In various embodiments the graphical user interface (GUI) of the display comprises a plurality of widgets with which a user (a caregiver or a patient) may interact. In one embodiment, the widgets are displayed as borderless windows or icons. In one embodiment, the widgets are set to a predefined location. In one embodiment, the widgets are non-resizable. Examples of the widgets comprise widgets for displaying patient health trends, lab data, event triggers, alarm history, clinical data, treatment protocols, launching clinical applications, launching hospital applications, or printing data.

In an embodiment, Windows Dynamic Network Access (WinDNA) provides access to custom applications running at fixed screen locations via the dynamic network access (DNA). Thus, in one embodiment, DNA is a software application that allows third party applications (such as, but not limited to HIS) running on another computer to host a session on the bedside monitor. The data to drive the display and to interact with the user at the display is exchanged via a network configuration.

Thus, WinDNA allows users to view and control Windows applications on the display. Input to the WinDNA can be done using a mouse, a keyboard, and via touch-screen. In one embodiment, a thin-client, embedded in the DNA-enabled display, allows the users to launch applications installed on the server using the hospital's existing network infrastructure.

FIG. 6 illustrates a block diagram of the power configuration **600** of a patient monitoring system that is employed, in one embodiment, to support and/or control dual display functionality. In one embodiment, the power configuration **600** includes a power supply component **610** and a backplane component **640**. The power supply component **610** and backplane component **640** interface via two separate connections. The first connection is an interface between a Power Supply I/F Connector **642** on the backplane component **640** and a Backplane I/F Connector **612** on the power supply component **610**. The second connection is an interface between an

SDLC Connector **644** on the backplane component **640** and an SDLC Connector **614** on the power supply component **610**.

Referring now to the power supply component **610**, the Backplane I/F Connector **612** interfaces with a CPU I/F Connector **616** through two power regulators **618** and a Power Fail Detect circuit **620**. Additionally, the CPU I/F Connector **616** has a USB interface with a USB Connector **622** on the power supply component **610**. Further, the power supply component **610** includes a Momentary Switch **624** which interfaces with a Switch Debouncer Circuit **626**, which, in turn interfaces with a Data or Delay Flip-Flop (D-FF) Circuit **628**. The D-FF **628** interfaces with the SDLC Connector **614** on the power supply component **610**.

Referring now to the backplane component **640**, the Power Supply I/F Connector **642** interfaces with a Lower Bay SDLC Connector **646** and an Upper Bay SDLC Connector **650** both directly and through a power regulator **648**. Both the Lower Bay SDLC Connector **646** and Upper Bay SDLC Connector **650** interface with additional power regulators **648**. The Power Supply I/F Connector **642** also interfaces with an External SDLC Connector **652** through an 18V En. **654** and 18V Connector **656**. The SDLC Connector **644** on the backplane component interfaces directly with the Lower Bay SDLC Connector **646**, Upper Bay SDLC Connector **650**, and External SDLC Connector **652**. Further, the SDLC Connector **644** also interfaces with the External SDLC Connector through a power regulator **648**.

Referring to FIG. 7, a display **701** comprises a data display region **702**, a plurality of data access buttons **704**, **705**, **706**, **707**, and a fixed region **703** that displays data accessed when the data access buttons **704**, **705**, **706**, **707** are activated. For example, when a trend button **704** is pressed or actuated, a command is transmitted to a virtual PC **708** which causes an application corresponding to conducting trend analyses to execute and access, retrieve, or otherwise obtain data from a database **709**. The accessed data is then communicated to a second server **710**, which formats the accessed data for display in region **703**. In one embodiment, the display of region **703** is controlled entirely by the second server **710**. It should be appreciated that each of the buttons **704**, **705**, **706**, **707** correspond to executing an application, which is stored in the memory of the virtual computer **708** and executed by a processor in the virtual computer **708**. In one embodiment, the data access button **704**, **705**, **706**, or **707** for whichever application is running is highlighted to inform the user which application is being displayed. It should further be appreciated that the buttons can be configured to cause applications on the Virtual PC to access data relevant to patient health trends, lab data, event triggers, alarm history, clinical data, or protocols, to launch checklists, to launch clinical applications, to launch hospital applications, or to print data.

In one embodiment, the buttons are caused to be displayed by a monitor that, upon boot up, accesses an XML configuration file which defines button location, size, graphic, text, what executable application on a remote PC is related to the displayed button, context parameters to pass, behavior of WinDNA at launch, such as fixed, float, border size, among other parameters.

Referring to FIGS. 8 and 9, which are architectural block diagrams of the dual display monitors, a top layer application class is driven by display, window manager, and event manager objects. The event manager object is further dependent upon various inputs, such as a mouse, cursor, and keyboard.

FIG. 10 is a flowchart illustrating the events that take place upon activation of a widget on a display monitor. A widget, such as a trend, alarm, or other data access button, is activated

1002. In an embodiment, widget activation triggers **1004** an event that launches an application with respect to a specific patient. The launched application **1006** runs on a virtual processing machine (computer). The application extracts **1008** data from a sorting database in which data obtained from patient bedside monitoring systems is stored. The extracted data **1010** is presented in the format of the application user interface on the display monitor via WinDNA.

Exemplary Use I

In one exemplary use, a 42 year old male motor cycle accident victim is mechanically ventilated in the Surgical Intensive Care Unit (SICU) of a large urban hospital. He suffered a ruptured spleen which was removed; fractured left leg, left arm, left ribs T6-9; and currently is in respiratory and renal failure. During the first 48 hours of admission he required high oxygen concentrations for severe hypoxemia which precipitated acute respiratory distress syndrome (ARDS). The critical trauma patient is diagnosed with multiple organ system failure and ARDS and is placed on permissive hypoxia protocol to prevent further damage from oxygen toxicity due to high fraction of inspired oxygen (FiO₂) settings on a ventilator.

The physician has written an order for oxygen weaning protocol (permissive hypoxia); the patient is on a cardiac monitor with clinical agent application and mechanical ventilation with supplemental oxygen. Minimal FiO₂ settings are maintained (O₂ concentration less than 40%) on the ventilator for improved patient outcome (less lung injury from prolonged high level oxygen therapy) and fewer SICU days. The oxygen weaning protocol ordered by the physician is displayed on the dual display monitor when the protocol widget is actuated. The protocol may be displayed in the second or fixed region of the monitor as “keep SpO₂ less than 92% but greater than 88% by decreasing ventilator O₂ concentration by 2% no more than once per hour.”

In an embodiment, this protocol is displayed in the basic clinical agent format and may (or may not) flash alerts when SpO₂ protocol levels are reached to hasten nurse/respiratory therapist work flow and more efficiently generate patient treatment which in turn may decrease number of SICU days. Without the protocol display, the nurse/therapist will have to locate protocols by time consuming searches through multiple files and, patient treatment and work flow would be less efficient.

Exemplary Use II

In another embodiment, a 78 year old female patient is awaiting ablation evaluation in Critical Care Unit (CCU), and persists with frequent episodes of Atrial fibrillation (AFib) lasting in excess of an hour. The patient is in CCU for evaluation of LA ablation to treat chronic persistent atrial fibrillation. She is on a cardiac monitor with ECG algorithm, oxygen at 2 L/min nasal cannula and has a history of dizziness, shortness of breath and fatigue.

The physician has written an order for AFib Burden Protocol while awaiting results for ablation evaluation. The patient has been classified as Class II-A for AFib and takes aspirin 81 mg, digoxin 0.14 mg and atenolol 50 mg daily. She has a peripheral IV maintenance line for access. The patient was safely treated pharmacologically for reversible episodes of A Fib. Her physician has placed her on his protocol of treatment for her specific classification and evidence of complications. The following protocol displays on the dual display monitor whenever the ECG algorithm detects A Fib and begins to track the amount of time A Fib is consistently present: “after 30 minutes of consistent A Fib, give 150 mg of amiodarone slow IVP (over 10 minutes) if PFTs with DLCO are on file, if no PFTs with DLCO, then give 20 mg/min

procainamide until 17 mg/kg dose is reached or until resolution of A Fib or until bradycardia (whichever occurs first).” The dual display monitor would also flash when the ECG rhythm returns to normal. Without the protocol display, the nurse will have to locate protocols by time consuming searches through multiple files and patient treatment and work flow would be less efficient.

Exemplary Use III In another embodiment, a 66 year old male was receiving treatment for alcoholic pancreatitis in the ICU of an urban hospital and experienced a heart attack. The patient is on a cardiac monitor with IV access. As the patient went into Ventricular fibrillation (V Fib) and the cardiac monitor began to sound an alarm, the attending nurse selected the Cardiopulmonary resuscitation (CPR) protocol button on the dual display monitor. The dual display monitor displayed the following: (1) the current Advanced Cardiac Life Support (ACLS) reference flowchart for decision making, (2) CPR medications calculated for this patient’s current weight and (3) a reference diagram with index of their hospital’s crash cart to aid in the location of medications and supplies. From the onset of CPR the on screen ACLS reference card was used for decision making and saved valuable time since the physician did not need to locate his card. The medication list was also time efficient as it was clearly displayed and patient specific.

As CPR progressed, the patient became more difficult to bag and mask ventilate, and the physician was unable to intubate. The decision was made to use an LAM device to ventilate the patient but the respiratory therapist could not locate one on the crash cart. Using the dual display monitor and index of the crash cart, the respiratory therapist was able to identify the location of the LAM device so it could be used to ventilate the patient until an anesthesiologist could arrive to intubate. After 27 minutes of effective and efficient CPR the patient was stabilized and placed on a ventilator.

Using the physician’s pocket ACLS card to direct care is the standard of care, but slows the process when the card is misplaced or difficult to read from age. Displaying ACLS protocol adjacent to the cardiac monitor on the DNA monitor is more time efficient during a critical procedure, allows for online medication calculations and improves readability. Searching a crash cart for supplies is a slow process and in the heat of the moment infrequently used items can be overlooked. Without the on screen display and index of the crash cart, the LAM device would not have been found and effective ventilation could not have been performed which may have altered the patient outcome.

Exemplary Use IV

In another embodiment, a cardiologist has a complex chronic heart failure patient in CCU with multiple intravascular lines in place on multiple medications to manage preload and after load. The cardiologist seeks to visualize and assess the effect of treatment options on hemodynamic indices. The patient is on a cardiac monitor with a DNA display, PA line and/or other device interfaces (such as USCOM) for continuous or episodic hemodynamic measures.

A 68 year old male patient with seven year chronic congestive heart failure history presents with both right and left side heart failure. Measures are available for SVI, CI, RVSWI, LVSWI, PVR, and SVR over a 24 hour period for a three day course of medication administration. The physician wants to plot the hemodynamic indices. Using the grid illustrated in FIG. 11, the dual display monitor interfaces with the data collection devices of the cardiac monitor and plots the hemodynamic values **1100**. Without the data grid display, the

physician will have to locate data by time consuming searches through multiple files and patient treatment and work flow would be less efficient.

Hence the dual display monitors may be used by clinicians or caregivers for accessing physiological waveforms and measurements as well as real time patient related information at the point of care (i.e., patient bedside) in order to provide speedy and accurate diagnosis and treatment.

Exemplary Use V

A 62 year old man is admitted to the emergency room due to a fainting episode at home. He is monitored while a number of different tests are run. While he is being monitored the clinical context manager is alerted that he has had two episodes of cardiac pause events that lasted 2.6 and 3.1 seconds; each of these events is posted to the external database. The monitor is configured to launch an application that reviews this data and retrieves the recommended clinical protocol which is to seek a cardiology consultation and to consider an implantable defibrillator. When the clinician returns to check on the patient she discovers the application displaying the recent event along with the suggested next steps.

The above examples are merely illustrative of the many applications of the system of the present invention. Although only a few embodiments of the present invention have been described herein, it should be understood that the present invention might be embodied in many other specific forms without departing from the spirit or scope of the invention. Therefore, the present examples and embodiments are to be considered as illustrative and not restrictive, and the invention may be modified within the scope of the appended claims.

We claim:

1. A patient monitoring system, comprising:
 - a display screen connected to a plurality of physiological parameter measuring devices, said display screen comprising a first region for displaying real time physiological parameter data and a second region separate from said first region;
 - a database comprising a memory for storing patient data; and
 - a controller programmed to generate a response to a critical event, said event comprising a physiological parameter exceeding or falling below a predetermined range of values, wherein said response comprises retrieving a recommended treatment protocol for the patient from said database to address the critical event and displaying said protocol on the second region of the display.
2. The system of claim 1, wherein the physiological parameter measuring devices comprise ECG, blood pressure, SpO₂, cardiac output, temperature, capnography, BIS, SvO₂ or EEG measuring devices.
3. The system of claim 1, wherein the database is remotely located.
4. The system of claim 1, wherein the patient data stored in the database includes patient health trends, lab data, event triggers, alarm history, clinical data, and treatment protocols.
5. The system of claim 1, wherein the display screen further comprises a plurality of data access buttons that can be actuated by a user to retrieve patient data.
6. The system of claim 1, wherein in an absence of a critical event, the second region of display screen is configured to launch applications for patient use.
7. A method for monitoring a patient, comprising:
 - connecting a display screen to a plurality of physiological parameter measuring devices, said display screen comprising a first region for displaying real time physiological parameter data and a second region separate from said first region;

storing patient data in a database comprising a memory; recognizing a critical event, said event comprising a physiological parameter exceeding or falling below a predetermined range of values;

based on recognizing a critical event, retrieving a recommended treatment protocol for the patient from said database to address the critical event; and displaying said protocol on the second region of the display.

8. The method of claim 7, wherein the physiological parameter measuring devices comprise ECG, blood pressure, SpO₂, cardiac output, temperature, capnography, BIS, SvO₂ or EEG measuring devices.

9. The method of claim 7, wherein the database is remotely located.

10. The method of claim 7, wherein the patient data stored in the database includes patient health trends, lab data, event triggers, alarm history, clinical data, and treatment protocols.

11. The method of claim 7, wherein the display screen further comprises a plurality of data access buttons that can be actuated by a user to retrieve patient data.

12. The method of claim 7 further comprising, using the second region of display screen to launch applications for patient use, in an absence of a critical event.

13. A patient monitoring system having a patient mode and in a caregiver mode, the system comprising:

- a display screen connected to a plurality of physiological parameter measuring devices, said display screen comprising a first region for displaying real time physiological parameter data and a second region separate from the first region;

- a database comprising a memory for storing patient data; and

- a controller programmed to activate a caregiver mode in response to a critical event and a patient mode in an absence of a critical event, wherein the caregiver mode comprises retrieving patient data from said database and displaying said patient data on the second region of the display, and the patient mode comprises enabling the second region to launch applications for patient use wherein said applications in the patient mode include one or more of Internet programs, email programs, patient education software, entertainment software, or video conferencing applications and wherein in the patient mode the display screen comprises a plurality of widgets configured to be actuated by a user to launch said applications.

14. The system of claim 13 wherein the critical event is at least one of an alarm, a physiological parameter exceeding a predefined threshold, a passage of time, a physiological parameter falling below a predefined threshold, or a detected disconnection of a sensor.

15. The system of claim 13, wherein the patient data stored in the database includes patient health trends, lab data, event triggers, alarm history, clinical data, and treatment protocols.

16. The system of claim 13, wherein the display screen further comprises a plurality of data access buttons configured to be actuated by a user to retrieve patient data.

17. The system of claim 13, wherein the physiological parameter measuring devices comprise ECG, blood pressure, SpO₂, cardiac output, temperature, capnography, BIS, SvO₂ or EEG measuring devices.

18. The system of claim 13, wherein, in the caregiver mode, said display is configured to provide access to clinical settings.

专利名称(译)	多显示器床边监控系统		
公开(公告)号	US9152765	公开(公告)日	2015-10-06
申请号	US14/165193	申请日	2014-01-27
[标]申请(专利权)人(译)	太空实验室健康护理有限公司		
申请(专利权)人(译)	太空实验室医疗		
当前申请(专利权)人(译)	太空实验室医疗LLC		
[标]发明人	GILHAM JEFFREY JAY JENSEN PATRICK BRENDL MICHAEL STANKUS KATHERINE		
发明人	GILHAM, JEFFREY JAY JENSEN, PATRICK BRENDL, MICHAEL STANKUS, KATHERINE		
IPC分类号	G08B23/00 G06F19/00 A61B5/00 G06F3/14		
CPC分类号	G06F19/3406 A61B5/002 G06F3/1438 G06F19/322 G06F19/345 G06F19/3487 G09G2380/08 G16H10/60 G16H15/00 G16H40/63 G16H40/67 G16H50/20 A61B5/04 A61B5/742		
优先权	61/315967 2010-03-21 US		
其他公开文献	US20140203937A1		
外部链接	Espacenet USPTO		

摘要(译)

本说明书中使用的显示区域，其中至少两个具有同时显示实时患者波形和生命统计，以及为本地和远程的软件应用程序提供的显示能力的多个公开的系统和方法用于患者监测。在一个示例中，主显示屏显示实时患者波形和生命统计而定制的辅助显示器显示的趋势，累积数据，实验室和放射学报告，协议，以及类似的临床信息。另外，辅助显示可以启动本地和远程应用，例如娱乐软件，互联网和电子邮件程序，患者教育软件和视频会议应用。所述双显示允许护理人员同时查看实时患者生命体征和聚集的数据或治疗方案，从而提高了医院工作人员的效率和改善的治疗，同时不损害关键报警或其它数据的显示。

