



US009107625B2

(12) **United States Patent**
Telfort et al.

(10) **Patent No.:** **US 9,107,625 B2**
(45) **Date of Patent:** **Aug. 18, 2015**

(54) **PULSE OXIMETRY SYSTEM WITH ELECTRICAL DECOUPLING CIRCUITRY**

(75) Inventors: **Valery G. Telfort**, Montreal (CA); **Ammar Al-Ali**, Tustin, CA (US); **Paul Martek**, Pierrefonds (CA)

(73) Assignee: **Masimo Corporation**, Irvine, CA (US)

(*) Notice: Subject to any disclaimer, the term of this patent is extended or adjusted under 35 U.S.C. 154(b) by 1024 days.

(21) Appl. No.: **12/436,015**

(22) Filed: **May 5, 2009**

(65) **Prior Publication Data**

US 2009/0299157 A1 Dec. 3, 2009

Related U.S. Application Data

(60) Provisional application No. 61/050,476, filed on May 5, 2008.

(51) **Int. Cl.**
A61B 5/00 (2006.01)
A61B 5/1455 (2006.01)
(Continued)

(52) **U.S. Cl.**
CPC **A61B 5/14552** (2013.01); **A61B 5/14551** (2013.01); **G02B 6/42** (2013.01); **G02B 6/43** (2013.01); **H04B 10/802** (2013.01);
(Continued)

(58) **Field of Classification Search**
CPC H01R 24/20–24/30; H01R 24/38–24/568; H01R 24/58; A61B 2562/22–2562/223; A61B 2562/225–2562/228; A61B 5/1455; G02B 6/42; G02B 6/43; H04B 10/802
USPC 439/92–108; 356/39–42; 307/326–328, 307/89–91

See application file for complete search history.

(56) **References Cited**

U.S. PATENT DOCUMENTS

3,682,161 A 8/1972 Alibert
3,808,502 A * 4/1974 Babilus 361/1
(Continued)

FOREIGN PATENT DOCUMENTS

CA 2262236 8/1999
EP 0716628 12/1998
(Continued)

OTHER PUBLICATIONS

U.S. Appl. No. 12/904,775, filed Oct. 14, 2010, Fechter et al.
(Continued)

Primary Examiner — William Thomson

Assistant Examiner — Marie Archer

(74) *Attorney, Agent, or Firm* — Knobbe Martens Olson & Bear, LLP

(57) **ABSTRACT**

A pulse oximetry system for reducing the risk of electric shock to a medical patient can include physiological sensors, at least one of which has a light emitter that can impinge light on body tissue of a living patient and a detector responsive to the light after attenuation by the body tissue. The detector can generate a signal indicative of a physiological characteristic of the living patient. The pulse oximetry system may also include a splitter cable that can connect the physiological sensors to a physiological monitor. The splitter cable may have a plurality of cable sections each including one or more electrical conductors that can interface with one of the physiological sensors. One or more decoupling circuits may be disposed in the splitter cable, which can be in communication with selected ones of the electrical conductors. The one or more decoupling circuits can electrically decouple the physiological sensors.

19 Claims, 17 Drawing Sheets

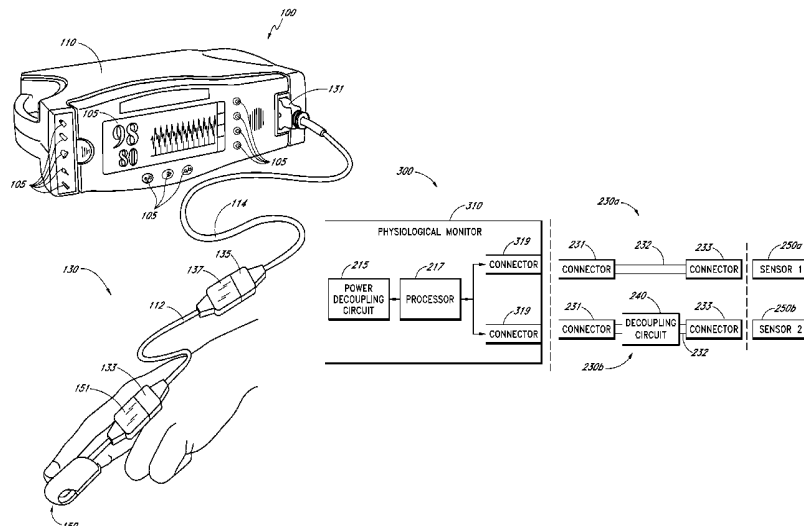

(51)	Int. Cl.		5,940,182 A	8/1999	Lepper, Jr. et al.	
	H04B 10/80	(2013.01)	5,995,855 A	11/1999	Kiani et al.	
	G02B 6/43	(2006.01)	5,997,343 A	12/1999	Mills et al.	
	G02B 6/42	(2006.01)	6,002,952 A	12/1999	Diab et al.	
	H01R 24/00	(2011.01)	6,011,986 A	1/2000	Diab et al.	
	G02B 6/00	(2006.01)	6,023,541 A *	2/2000	Merchant et al.	385/20
	H04B 10/00	(2013.01)	6,027,452 A	2/2000	Flaherty et al.	
	H01R 24/22	(2011.01)	6,036,642 A	3/2000	Diab et al.	
			6,045,509 A	4/2000	Caro et al.	
(52)	U.S. Cl.		6,067,462 A	5/2000	Diab et al.	
	CPC	<i>A61B2560/045</i> (2013.01); <i>A61B 2562/08</i> (2013.01); <i>A61B 2562/222</i> (2013.01); <i>A61B</i> <i>2562/227</i> (2013.01); <i>H01R 24/22</i> (2013.01)	6,081,735 A	6/2000	Diab et al.	
			6,088,607 A	7/2000	Diab et al.	
			6,110,522 A	8/2000	Lepper, Jr. et al.	
			6,124,597 A	9/2000	Shehada et al.	
			6,128,521 A	10/2000	Marro et al.	
			6,129,675 A	10/2000	Jay	
			6,144,868 A	11/2000	Parker	
(56)	References Cited		6,151,516 A	11/2000	Kiani-Azarbayjany et al.	
	U.S. PATENT DOCUMENTS		6,152,754 A	11/2000	Gerhardt et al.	
			6,157,850 A	12/2000	Diab et al.	
			6,165,005 A	12/2000	Mills et al.	
			6,184,521 B1	2/2001	Coffin, IV et al.	
			6,188,470 B1	2/2001	Grace	
			6,206,830 B1	3/2001	Diab et al.	
			6,229,856 B1	5/2001	Diab et al.	
			6,232,609 B1	5/2001	Snyder et al.	
			6,236,872 B1	5/2001	Diab et al.	
			6,241,683 B1	6/2001	Macklem et al.	
			6,248,083 B1	6/2001	Smith et al.	
			6,253,097 B1	6/2001	Aronow et al.	
			6,256,523 B1	7/2001	Diab et al.	
			6,263,222 B1	7/2001	Diab et al.	
			6,278,522 B1	8/2001	Lepper, Jr. et al.	
			6,280,213 B1	8/2001	Tobler et al.	
			6,285,896 B1	9/2001	Tobler et al.	
			6,301,493 B1	10/2001	Marro et al.	
			6,317,627 B1	11/2001	Ennen et al.	
			6,321,100 B1	11/2001	Parker	
			6,325,761 B1	12/2001	Jay	
			6,334,065 B1	12/2001	Al-Ali et al.	
			6,343,224 B1	1/2002	Parker	
			6,349,228 B1	2/2002	Kiani et al.	
			6,360,114 B1	3/2002	Diab et al.	
			6,368,283 B1	4/2002	Xu et al.	
			6,371,921 B1	4/2002	Caro et al.	
			6,377,829 B1	4/2002	Al-Ali	
			6,388,240 B2	5/2002	Schulz et al.	
			6,397,091 B2	5/2002	Diab et al.	
			6,430,437 B1	8/2002	Marro	
			6,430,525 B1	8/2002	Weber et al.	
			6,463,311 B1	10/2002	Diab	
			6,470,199 B1	10/2002	Kopotic et al.	
			6,486,588 B2	11/2002	Doron et al.	
			6,501,975 B2	12/2002	Diab et al.	
			6,505,059 B1	1/2003	Kollias et al.	
			6,515,273 B2	2/2003	Al-Ali	
			6,517,497 B2	2/2003	Rymut et al.	
			6,519,487 B1	2/2003	Parker	
			6,520,918 B1 *	2/2003	Stergiopoulos et al.	600/490
			6,525,386 B1	2/2003	Mills et al.	
			6,526,300 B1	2/2003	Kiani et al.	
			6,541,756 B2	4/2003	Schulz et al.	
			6,542,764 B1	4/2003	Al-Ali et al.	
			6,580,086 B1	6/2003	Schulz et al.	
			6,584,336 B1	6/2003	Ali et al.	
			6,595,316 B2	7/2003	Cybulski et al.	
			6,597,932 B2	7/2003	Tian et al.	
			6,597,933 B2	7/2003	Kiani et al.	
			6,606,511 B1	8/2003	Ali et al.	
			6,632,181 B2	10/2003	Flaherty et al.	
			6,639,668 B1	10/2003	Trepagnier	
			6,640,116 B2	10/2003	Diab	
			6,643,530 B2	11/2003	Diab et al.	
			6,650,917 B2	11/2003	Diab et al.	
			6,654,624 B2	11/2003	Diab et al.	
			6,658,276 B2	12/2003	Pishney et al.	
			6,661,161 B1	12/2003	Lanzo et al.	
			6,671,531 B2	12/2003	Al-Ali et al.	
			6,678,543 B2	1/2004	Diab et al.	

(56)

References Cited

U.S. PATENT DOCUMENTS

6,684,090	B2	1/2004	Ali et al.	D554,263	S	10/2007	Al-Ali
6,684,091	B2	1/2004	Parker	7,280,858	B2	10/2007	Al-Ali et al.
6,697,656	B1	2/2004	Al-Ali	7,289,835	B2	10/2007	Mansfield et al.
6,697,657	B1	2/2004	Shehada et al.	7,292,883	B2	11/2007	De Felice et al.
6,697,658	B2	2/2004	Al-Ali	7,295,866	B2	11/2007	Al-Ali
RE38,476	E	3/2004	Diab et al.	7,328,053	B1	2/2008	Diab et al.
6,699,194	B1	3/2004	Diab et al.	7,332,784	B2	2/2008	Mills et al.
6,714,804	B2	3/2004	Al-Ali et al.	7,340,287	B2	3/2008	Mason et al.
RE38,492	E	4/2004	Diab et al.	7,341,559	B2	3/2008	Schulz et al.
6,721,582	B2	4/2004	Trepagnier et al.	7,343,186	B2	3/2008	Lamego et al.
6,721,585	B1	4/2004	Parker	D566,282	S	4/2008	Al-Ali et al.
6,725,075	B2	4/2004	Al-Ali	7,355,512	B1	4/2008	Al-Ali
6,728,560	B2	4/2004	Kollias et al.	7,356,365	B2	4/2008	Schurman
6,735,459	B2	5/2004	Parker	7,371,981	B2	5/2008	Abdul-Hafiz
6,745,060	B2	6/2004	Diab et al.	7,373,193	B2	5/2008	Al-Ali et al.
6,760,607	B2	7/2004	Al-Ali	7,373,194	B2	5/2008	Weber et al.
6,770,028	B1	8/2004	Ali et al.	7,376,453	B1	5/2008	Diab et al.
6,771,994	B2	8/2004	Kiani et al.	7,377,794	B2	5/2008	Al-Ali et al.
6,792,300	B1	9/2004	Diab et al.	7,377,899	B2	5/2008	Weber et al.
6,813,511	B2	11/2004	Diab et al.	7,383,070	B2	6/2008	Diab et al.
6,816,741	B2	11/2004	Diab	7,415,297	B2	8/2008	Al-Ali et al.
6,822,564	B2	11/2004	Al-Ali	7,428,432	B2	9/2008	Ali et al.
6,826,419	B2	11/2004	Diab et al.	7,438,683	B2	10/2008	Al-Ali et al.
6,830,711	B2	12/2004	Mills et al.	7,440,787	B2	10/2008	Diab
6,850,787	B2	2/2005	Weber et al.	7,454,240	B2	11/2008	Diab et al.
6,850,788	B2	2/2005	Al-Ali	7,467,002	B2	12/2008	Weber et al.
6,852,083	B2	2/2005	Caro et al.	7,469,157	B2	12/2008	Diab et al.
6,861,639	B2	3/2005	Al-Ali	7,471,969	B2	12/2008	Diab et al.
6,898,452	B2	5/2005	Al-Ali et al.	7,471,971	B2	12/2008	Diab et al.
6,918,878	B2*	7/2005	Brodnick 600/483	7,483,729	B2	1/2009	Al-Ali et al.
6,920,345	B2	7/2005	Al-Ali et al.	7,483,730	B2	1/2009	Diab et al.
6,931,268	B1	8/2005	Kiani-Azarbayjany et al.	7,489,958	B2	2/2009	Diab et al.
6,934,570	B2	8/2005	Kiani et al.	7,496,391	B2	2/2009	Diab et al.
6,939,305	B2	9/2005	Flaherty et al.	7,496,393	B2	2/2009	Diab et al.
6,943,348	B1	9/2005	Coffin, IV	D587,657	S	3/2009	Al-Ali et al.
6,950,687	B2	9/2005	Al-Ali	7,499,741	B2	3/2009	Diab et al.
6,961,598	B2	11/2005	Diab	7,499,835	B2	3/2009	Weber et al.
6,970,792	B1	11/2005	Diab	7,500,950	B2	3/2009	Al-Ali et al.
6,979,812	B2	12/2005	Al-Ali	7,509,154	B2	3/2009	Diab et al.
6,985,764	B2	1/2006	Mason et al.	7,509,494	B2	3/2009	Al-Ali
6,993,371	B2	1/2006	Kiani et al.	7,510,849	B2	3/2009	Schurman et al.
6,996,427	B2	2/2006	Ali et al.	7,526,328	B2	4/2009	Diab et al.
6,999,904	B2	2/2006	Weber et al.	7,530,942	B1	5/2009	Diab
7,003,338	B2	2/2006	Weber et al.	7,530,949	B2	5/2009	Al-Ali et al.
7,003,339	B2	2/2006	Diab et al.	7,530,955	B2	5/2009	Diab et al.
7,015,451	B2	3/2006	Dalke et al.	7,563,110	B2	7/2009	Al-Ali et al.
7,024,233	B2	4/2006	Ali et al.	7,596,398	B2	9/2009	Al-Ali et al.
7,027,849	B2	4/2006	Al-Ali	7,618,375	B2	11/2009	Flaherty
7,030,749	B2	4/2006	Al-Ali	D606,659	S	12/2009	Kiani et al.
7,039,449	B2	5/2006	Al-Ali	7,647,083	B2	1/2010	Al-Ali et al.
7,041,060	B2	5/2006	Flaherty et al.	D609,193	S	2/2010	Al-Ali et al.
7,044,918	B2	5/2006	Diab	D614,305	S	4/2010	Al-Ali et al.
7,067,893	B2	6/2006	Mills et al.	RE41,317	E	5/2010	Parker
7,096,052	B2	8/2006	Mason et al.	7,729,733	B2	6/2010	Al-Ali et al.
7,096,054	B2	8/2006	Abdul-Hafiz et al.	7,734,320	B2	6/2010	Al-Ali
7,096,060	B2	8/2006	Arand et al.	7,761,127	B2	7/2010	Al-Ali et al.
7,132,641	B2	11/2006	Schulz et al.	7,761,128	B2	7/2010	Al-Ali et al.
7,142,901	B2	11/2006	Kiani et al.	7,764,982	B2	7/2010	Dalke et al.
7,149,561	B2	12/2006	Diab	D621,516	S	8/2010	Kiani et al.
7,186,966	B2	3/2007	Al-Ali	7,791,155	B2	9/2010	Diab
7,190,261	B2	3/2007	Al-Ali	7,801,581	B2	9/2010	Diab
7,215,984	B2	5/2007	Diab et al.	7,822,452	B2	10/2010	Schurman et al.
7,215,986	B2	5/2007	Diab	RE41,912	E	11/2010	Parker
7,221,971	B2	5/2007	Diab	7,844,313	B2	11/2010	Kiani et al.
7,225,006	B2	5/2007	Al-Ali et al.	7,844,314	B2	11/2010	Al-Ali
7,225,007	B2	5/2007	Al-Ali	7,844,315	B2	11/2010	Al-Ali
RE39,672	E	6/2007	Shehada et al.	7,865,222	B2	1/2011	Weber et al.
7,239,905	B2	7/2007	Kiani-Azarbayjany et al.	7,873,497	B2	1/2011	Weber et al.
7,245,953	B1	7/2007	Parker	7,880,606	B2	2/2011	Al-Ali
7,254,429	B2	8/2007	Schurman et al.	7,880,626	B2	2/2011	Al-Ali et al.
7,254,431	B2	8/2007	Al-Ali	7,891,355	B2	2/2011	Al-Ali et al.
7,254,433	B2	8/2007	Diab et al.	7,894,868	B2	2/2011	Al-Ali et al.
7,254,434	B2	8/2007	Schulz et al.	7,899,507	B2	3/2011	Al-Ali et al.
7,272,425	B2	9/2007	Al-Ali	7,899,518	B2	3/2011	Trepagnier et al.
7,274,955	B2	9/2007	Kiani et al.	7,904,132	B2	3/2011	Weber et al.
				7,909,772	B2	3/2011	Popov et al.
				7,910,875	B2	3/2011	Al-Ali
				7,919,713	B2	4/2011	Al-Ali et al.
				7,937,128	B2	5/2011	Al-Ali

(56)

References Cited

U.S. PATENT DOCUMENTS

7,937,129	B2	5/2011	Mason et al.	8,430,817	B1	4/2013	Al-Ali et al.
7,937,130	B2	5/2011	Diab et al.	8,437,825	B2	5/2013	Dalvi et al.
7,941,199	B2	5/2011	Kiani	8,455,290	B2	6/2013	Siskavich
7,951,086	B2	5/2011	Flaherty et al.	8,457,703	B2	6/2013	Al-Ali
7,957,780	B2	6/2011	Lamego et al.	8,457,707	B2	6/2013	Kiani
7,962,188	B2	6/2011	Kiani et al.	8,463,349	B2	6/2013	Diab et al.
7,962,190	B1	6/2011	Diab et al.	8,466,286	B2	6/2013	Bellot et al.
7,976,472	B2	7/2011	Kiani	8,471,713	B2	6/2013	Poeze et al.
7,988,637	B2	8/2011	Diab	8,473,020	B2	6/2013	Kiani et al.
7,990,382	B2	8/2011	Kiani	8,483,787	B2	7/2013	Al-Ali et al.
7,991,446	B2	8/2011	Al-Ali et al.	8,489,364	B2	7/2013	Weber et al.
8,000,761	B2	8/2011	Al-Ali	8,498,684	B2	7/2013	Weber et al.
8,008,088	B2	8/2011	Bellott et al.	8,504,128	B2	8/2013	Blank et al.
RE42,753	E	9/2011	Kiani-Azarbayjany et al.	8,509,867	B2	8/2013	Workman et al.
8,019,400	B2	9/2011	Diab et al.	8,515,509	B2	8/2013	Bruinsma et al.
8,028,701	B2	10/2011	Al-Ali et al.	8,523,781	B2	9/2013	Al-Ali
8,029,765	B2	10/2011	Bellott et al.	8,529,301	B2	9/2013	Al-Ali et al.
8,036,727	B2	10/2011	Schurman et al.	8,532,727	B2	9/2013	Ali et al.
8,036,728	B2	10/2011	Diab et al.	8,532,728	B2	9/2013	Diab et al.
8,046,040	B2	10/2011	Ali et al.	D692,145	S	10/2013	Al-Ali et al.
8,046,041	B2	10/2011	Diab et al.	8,547,209	B2	10/2013	Kiani et al.
8,046,042	B2	10/2011	Diab et al.	8,548,548	B2	10/2013	Al-Ali
8,048,040	B2	11/2011	Kiani	8,548,549	B2	10/2013	Schurman et al.
8,050,728	B2	11/2011	Al-Ali et al.	8,548,550	B2	10/2013	Al-Ali et al.
RE43,169	E	2/2012	Parker	8,560,032	B2	10/2013	Al-Ali et al.
8,118,620	B2	2/2012	Al-Ali et al.	8,560,034	B1	10/2013	Diab et al.
8,126,528	B2	2/2012	Diab et al.	8,570,167	B2	10/2013	Al-Ali
8,128,572	B2	3/2012	Diab et al.	8,570,503	B2	10/2013	Vo et al.
8,130,105	B2	3/2012	Al-Ali et al.	8,571,617	B2	10/2013	Reichgott et al.
8,145,287	B2	3/2012	Diab et al.	8,571,618	B1	10/2013	Lamego et al.
8,150,487	B2	4/2012	Diab et al.	8,571,619	B2	10/2013	Al-Ali et al.
8,175,672	B2	5/2012	Parker	8,577,431	B2	11/2013	Lamego et al.
8,180,420	B2	5/2012	Diab et al.	8,581,732	B2	11/2013	Al-Ali et al.
8,182,443	B1	5/2012	Kiani	8,584,345	B2	11/2013	Al-Ali et al.
8,185,180	B2	5/2012	Diab et al.	8,588,880	B2	11/2013	Abdul-Hafiz et al.
8,190,223	B2	5/2012	Al-Ali et al.	8,600,467	B2	12/2013	Al-Ali et al.
8,190,227	B2	5/2012	Diab et al.	8,606,342	B2	12/2013	Diab
8,203,438	B2	6/2012	Kiani et al.	8,626,255	B2	1/2014	Al-Ali et al.
8,203,704	B2	6/2012	Merritt et al.	8,630,691	B2	1/2014	Lamego et al.
8,204,566	B2	6/2012	Schurman et al.	8,634,889	B2	1/2014	Al-Ali et al.
8,219,172	B2	7/2012	Schurman et al.	8,641,631	B2	2/2014	Sierra et al.
8,224,411	B2	7/2012	Al-Ali et al.	8,652,060	B2	2/2014	Al-Ali
8,228,181	B2	7/2012	Al-Ali	8,663,107	B2	3/2014	Kiani
8,229,533	B2	7/2012	Diab et al.	8,666,468	B1	3/2014	Al-Ali
8,233,955	B2	7/2012	Al-Ali et al.	8,667,967	B2	3/2014	Al-Ali et al.
8,244,325	B2	8/2012	Al-Ali et al.	8,670,811	B2	3/2014	O'Reilly
8,255,026	B1	8/2012	Al-Ali	8,670,814	B2	3/2014	Diab et al.
8,255,027	B2	8/2012	Al-Ali et al.	8,676,286	B2	3/2014	Weber et al.
8,255,028	B2	8/2012	Al-Ali et al.	8,682,407	B2	3/2014	Al-Ali
8,260,577	B2	9/2012	Weber et al.	RE44,823	E	4/2014	Parker
8,265,723	B1	9/2012	McHale et al.	RE44,875	E	4/2014	Kiani et al.
8,274,360	B2	9/2012	Sampath et al.	8,690,799	B2	4/2014	Telfort et al.
8,301,217	B2	10/2012	Al-Ali et al.	8,700,112	B2	4/2014	Kiani
8,306,596	B2	11/2012	Schurman et al.	8,702,627	B2	4/2014	Telfort et al.
8,310,336	B2	11/2012	Muhsin et al.	8,706,179	B2	4/2014	Parker
8,315,683	B2	11/2012	Al-Ali et al.	8,712,494	B1	4/2014	MacNeish, III et al.
RE43,860	E	12/2012	Parker	8,715,206	B2	5/2014	Telfort et al.
8,337,403	B2	12/2012	Al-Ali et al.	8,718,735	B2	5/2014	Lamego et al.
8,346,330	B2	1/2013	Lamego	8,718,737	B2	5/2014	Diab et al.
8,353,842	B2	1/2013	Al-Ali et al.	8,718,738	B2	5/2014	Blank et al.
8,355,766	B2	1/2013	MacNeish, III et al.	8,720,249	B2	5/2014	Al-Ali
8,359,080	B2	1/2013	Diab et al.	8,721,541	B2	5/2014	Al-Ali et al.
8,364,223	B2	1/2013	Al-Ali et al.	8,721,542	B2	5/2014	Al-Ali et al.
8,364,226	B2	1/2013	Diab et al.	8,723,677	B1	5/2014	Kiani
8,374,665	B2	2/2013	Lamego	8,740,792	B1	6/2014	Kiani et al.
8,385,995	B2	2/2013	Al-Ali et al.	8,754,776	B2	6/2014	Poeze et al.
8,385,996	B2	2/2013	Smith et al.	8,755,535	B2	6/2014	Telfort et al.
8,388,353	B2	3/2013	Kiani et al.	8,755,856	B2	6/2014	Diab et al.
8,399,822	B2	3/2013	Al-Ali	8,755,872	B1	6/2014	Marinow
8,401,602	B2	3/2013	Kiani	8,761,850	B2	6/2014	Lamego
8,405,608	B2	3/2013	Al-Ali et al.	8,764,671	B2	7/2014	Kiani
8,414,499	B2	4/2013	Al-Ali et al.	8,768,423	B2	7/2014	Shakespeare et al.
8,418,524	B2	4/2013	Al-Ali	8,771,204	B2	7/2014	Telfort et al.
8,423,106	B2	4/2013	Lamego et al.	8,777,634	B2	7/2014	Kiani et al.
8,428,967	B2	4/2013	Olsen et al.	8,781,543	B2	7/2014	Diab et al.
				8,781,544	B2	7/2014	Al-Ali et al.
				8,781,549	B2	7/2014	Al-Ali et al.
				8,788,003	B2	7/2014	Schurman et al.
				8,790,268	B2	7/2014	Al-Ali

(56)

References Cited

U.S. PATENT DOCUMENTS

8,801,613	B2	8/2014	Al-Ali et al.	2013/0045685	A1	2/2013	Kiani
8,821,397	B2	9/2014	Al-Ali et al.	2013/0046204	A1	2/2013	Lamego et al.
8,821,415	B2	9/2014	Al-Ali et al.	2013/0060108	A1	3/2013	Schurman et al.
8,830,449	B1	9/2014	Lamego et al.	2013/0060147	A1	3/2013	Welch et al.
8,831,700	B2	9/2014	Schurman et al.	2013/0079610	A1	3/2013	Al-Ali
8,840,549	B2	9/2014	Al-Ali et al.	2013/0096405	A1	4/2013	Garfio
8,847,740	B2	9/2014	Kiani et al.	2013/0096936	A1	4/2013	Sampath et al.
8,849,365	B2	9/2014	Smith et al.	2013/0109935	A1	5/2013	Al-Ali et al.
8,852,094	B2	10/2014	Al-Ali et al.	2013/0162433	A1	6/2013	Muhsin et al.
8,852,994	B2	10/2014	Wojtczuk et al.	2013/0178749	A1	7/2013	Lamego
8,868,147	B2	10/2014	Stippick et al.	2013/0190581	A1	7/2013	Al-Ali et al.
8,868,150	B2	10/2014	Al-Ali et al.	2013/0197328	A1	8/2013	Diab et al.
8,870,792	B2	10/2014	Al-Ali et al.	2013/0211214	A1	8/2013	Olsen
8,886,271	B2	11/2014	Kiani et al.	2013/0243021	A1	9/2013	Siskavich
8,888,539	B2	11/2014	Al-Ali et al.	2013/0253334	A1	9/2013	Al-Ali et al.
8,888,708	B2	11/2014	Diab et al.	2013/0274571	A1	10/2013	Diab et al.
8,892,180	B2	11/2014	Weber et al.	2013/0296672	A1	11/2013	O'Neil et al.
8,897,847	B2	11/2014	Al-Ali	2013/0317370	A1	11/2013	Dalvi et al.
8,909,310	B2	12/2014	Lamego et al.	2013/0324808	A1	12/2013	Al-Ali et al.
8,911,377	B2	12/2014	Al-Ali	2013/0331670	A1	12/2013	Kiani
8,912,909	B2	12/2014	Al-Ali et al.	2013/0338461	A1	12/2013	Lamego et al.
8,920,317	B2	12/2014	Al-Ali et al.	2014/0012100	A1	1/2014	Al-Ali et al.
8,921,699	B2	12/2014	Al-Ali et al.	2014/0025306	A1	1/2014	Weber et al.
8,922,382	B2	12/2014	Al-Ali et al.	2014/0034353	A1	2/2014	Al-Ali et al.
8,929,964	B2	1/2015	Al-Ali et al.	2014/0051952	A1	2/2014	Reichgott et al.
8,942,777	B2	1/2015	Diab et al.	2014/0051953	A1	2/2014	Lamego et al.
8,948,834	B2	2/2015	Diab et al.	2014/0051954	A1	2/2014	Al-Ali et al.
8,948,835	B2	2/2015	Diab	2014/0058230	A1	2/2014	Abdul-Hafiz et al.
2002/0193670	A1	12/2002	Garfield et al.	2014/0066783	A1	3/2014	Kiani et al.
2003/0015368	A1	1/2003	Cybulski et al.	2014/0077956	A1	3/2014	Sampath et al.
2003/0135129	A1 *	7/2003	Cusimano et al. 600/546	2014/0081100	A1	3/2014	Muhsin et al.
2004/0158162	A1	8/2004	Narimatsu	2014/0081175	A1	3/2014	Telfort
2004/0267103	A1 *	12/2004	Li et al. 600/323	2014/0094667	A1	4/2014	Schurman et al.
2005/0283059	A1	12/2005	Iyer et al.	2014/0100434	A1	4/2014	Diab et al.
2006/0047215	A1	3/2006	Newman et al.	2014/0114199	A1	4/2014	Lamego et al.
2006/0238333	A1	10/2006	Welch et al.	2014/0120564	A1	5/2014	Workman et al.
2007/0149864	A1	6/2007	Laakkonen	2014/0121482	A1	5/2014	Merritt et al.
2007/0185393	A1	8/2007	Zhou et al.	2014/0121483	A1	5/2014	Kiani
2007/0185397	A1	8/2007	Govari et al.	2014/0125495	A1	5/2014	Al-Ali
2007/0282212	A1	12/2007	Sierra et al.	2014/0127137	A1	5/2014	Bellott et al.
2008/0076972	A1	3/2008	Dorogusker et al.	2014/0128696	A1	5/2014	Al-Ali
2009/0018429	A1	1/2009	Saliga et al.	2014/0128699	A1	5/2014	Al-Ali et al.
2009/0028173	A1 *	1/2009	Bliss et al. 370/432	2014/0129702	A1	5/2014	Lamego et al.
2009/0093687	A1	4/2009	Telfort et al.	2014/0135588	A1	5/2014	Al-Ali et al.
2009/0187065	A1	7/2009	Basinger	2014/0142401	A1	5/2014	Al-Ali et al.
2009/0247984	A1	10/2009	Lamego et al.	2014/0142402	A1	5/2014	Al-Ali et al.
2009/0275844	A1	11/2009	Al-Ali	2014/0163344	A1	6/2014	Al-Ali
2009/0299157	A1	12/2009	Telfort et al.	2014/0163402	A1	6/2014	Lamego et al.
2010/0004518	A1	1/2010	Vo et al.	2014/0166076	A1	6/2014	Kiani et al.
2010/0030040	A1	2/2010	Poeze et al.	2014/0171763	A1	6/2014	Diab
2010/0261979	A1	10/2010	Kiani	2014/0180038	A1	6/2014	Kiani
2010/0274099	A1	10/2010	Telfort et al.	2014/0180154	A1	6/2014	Sierra et al.
2010/0317936	A1	12/2010	Al-Ali et al.	2014/0194709	A1	7/2014	Al-Ali et al.
2011/0001605	A1	1/2011	Kiani et al.	2014/0194711	A1	7/2014	Al-Ali
2011/0082711	A1	4/2011	Poeze et al.	2014/0194766	A1	7/2014	Al-Ali et al.
2011/0105854	A1	5/2011	Kiani et al.	2014/0200420	A1	7/2014	Al-Ali
2011/0208015	A1	8/2011	Welch et al.	2014/0200422	A1	7/2014	Weber et al.
2011/0209915	A1	9/2011	Telfort et al.	2014/0206963	A1	7/2014	Al-Ali
2011/0213212	A1	9/2011	Al-Ali	2014/0213864	A1	7/2014	Abdul-Hafiz et al.
2011/0230733	A1	9/2011	Al-Ali	2014/0243627	A1	8/2014	Diab et al.
2011/0237911	A1	9/2011	Lamego et al.	2014/0266790	A1	9/2014	Al-Ali et al.
2012/0059267	A1	3/2012	Lamego et al.	2014/0275808	A1	9/2014	Poeze et al.
2012/0116175	A1	5/2012	Al-Ali et al.	2014/0275835	A1	9/2014	Lamego et al.
2012/0179006	A1	7/2012	Jansen et al.	2014/0275871	A1	9/2014	Lamego et al.
2012/0209082	A1	8/2012	Al-Ali	2014/0275872	A1	9/2014	Merritt et al.
2012/0209084	A1	8/2012	Olsen et al.	2014/0275881	A1	9/2014	Lamego et al.
2012/0227739	A1	9/2012	Kiani	2014/0288400	A1	9/2014	Diab et al.
2012/0265039	A1	10/2012	Kiani	2014/0296664	A1	10/2014	Bruinsma et al.
2012/0283524	A1	11/2012	Kiani et al.	2014/0303520	A1	10/2014	Telfort et al.
2012/0286955	A1	11/2012	Welch et al.	2014/0309506	A1	10/2014	Lamego et al.
2012/0296178	A1	11/2012	Lamego et al.	2014/0309559	A1	10/2014	Telfort et al.
2012/0319816	A1	12/2012	Al-Ali	2014/0316228	A1	10/2014	Blank et al.
2012/0330112	A1	12/2012	Lamego et al.	2014/0323825	A1	10/2014	Al-Ali et al.
2013/0023775	A1	1/2013	Lamego et al.	2014/0330092	A1	11/2014	Al-Ali et al.
2013/0041591	A1	2/2013	Lamego	2014/0330098	A1	11/2014	Merritt et al.
				2014/0330099	A1	11/2014	Al-Ali et al.
				2014/0333440	A1	11/2014	Kiani

(56)

References Cited

U.S. PATENT DOCUMENTS

2014/0336481 A1 11/2014 Shakespeare et al.
 2014/0343436 A1 11/2014 Kiani
 2015/0018650 A1 1/2015 Al-Ali et al.

FOREIGN PATENT DOCUMENTS

EP	0659058	1/1999
EP	1207536	5/2002
GB	2358546	11/1999
JP	6214898	1/1987
JP	01-309872	6/1998
JP	10-155755	6/1998
JP	2001-50713	5/1999
JP	2003-329719	11/2003
WO	WO 94/05207	3/1994
WO	WO 94/13207	6/1994
WO	WO 95/29632	11/1995
WO	WO 99/53277	10/1999
WO	WO 00/10462	3/2000
WO	WO 01/34033	5/2001
WO	WO 01/78059	10/2001
WO	WO 01/97691	12/2001
WO	WO 02/03042	1/2002
WO	WO 02/24067	3/2002
WO	WO 03/058646	7/2003
WO	WO 03/087737	10/2003
WO	WO 2004/000111	12/2003
WO	WO 2004/004411	1/2004
WO	WO 2005/096931	10/2005
WO	WO 2005/099562	10/2005
WO	WO 2008/017246	2/2008
WO	WO 2008/148172	12/2008
WO	WO 2009/137524	11/2009

OTHER PUBLICATIONS

U.S. Appl. No. 12/904,789, filed Oct. 14, 2010, Telfort, Valery et al.
 U.S. Appl. No. 12/904,823, filed Oct. 14, 2010, Al-Ali et al.

U.S. Appl. No. 12/904,836, filed Oct. 14, 2010, Al-Ali, Ammar.
 U.S. Appl. No. 12/904,890, filed Oct. 14, 2010, Telfort et al.
 U.S. Appl. No. 12/904,907, filed Oct. 14, 2010, Telfort.
 U.S. Appl. No. 12/904,931, filed Oct. 14, 2010, Telfort et al.
 U.S. Appl. No. 12/904,938, filed Oct. 14, 2010, Telfort et al.
 U.S. Appl. No. 12/905,036, filed Oct. 14, 2010, Kiani et al.
 U.S. Appl. No. 12/905,384, filed Oct. 15, 2010, Al-Ali et al.
 U.S. Appl. No. 12/905,449, filed Oct. 15, 2010, Al-Ali et al.
 U.S. Appl. No. 12/905,489, filed Oct. 15, 2010, Weber et al.
 U.S. Appl. No. 12/905,530, filed Oct. 15, 2010, Al-Ali et al.
 U.S. Appl. No. 12/960,325, filed Dec. 3, 2010, Al-Ali, Ammar et al.
 Analog Devices, 12-Bit Serial Input Multiplying D/A Converter, Product Data Sheet, 2000.
 International Search Report & Written Opinion, PCT Application PCT/US2010/052758, Feb. 10, 2011; 12 pages.
 International Search Report & Written Opinion, PCT Application PCT/US2010/058981, Feb. 17, 2011; 11 pages.
 International Search Report, PCT Application PCT/CA2003/000536, Dec. 11, 2003; 2 pages.
 International Search Report, PCT Application PCT/US2009/069287, Mar. 30, 2010; 7 pages.
 Welch Allyn, ECG ASIC, Product Data Sheet, 2001.
 Sierra et al., Monitoring Respiratory Rate Based on Tracheal Sounds. First Experiences, Proceedings of the 26th Annual Int'l Conf. of the IEEE EMBS (Sep. 2004), 317-320.
 WelchAllyn OEM Technologies, ECG ASIC, ECG 3-lead, 5-lead, 12-lead and RESP Signal Processing, ECG ASIC Part No. 000. 91163.
 International Search Report and Written Opinion from PCT/US2009/042902, mailed Aug. 12, 2009.
 Analog Devices, 12-Bit Serial Input Multiplying D/A Converter, DAC8043A. Analog Devices, Inc., 2000.
 Avago Technologies, HCNR200 and HCNR201, High-Linearity Analog Optocouplers, Data Sheet, Avago Technologies, Nov. 18, 2008.
 US 8,845,543, 09/2014, Diab et al. (withdrawn)

* cited by examiner

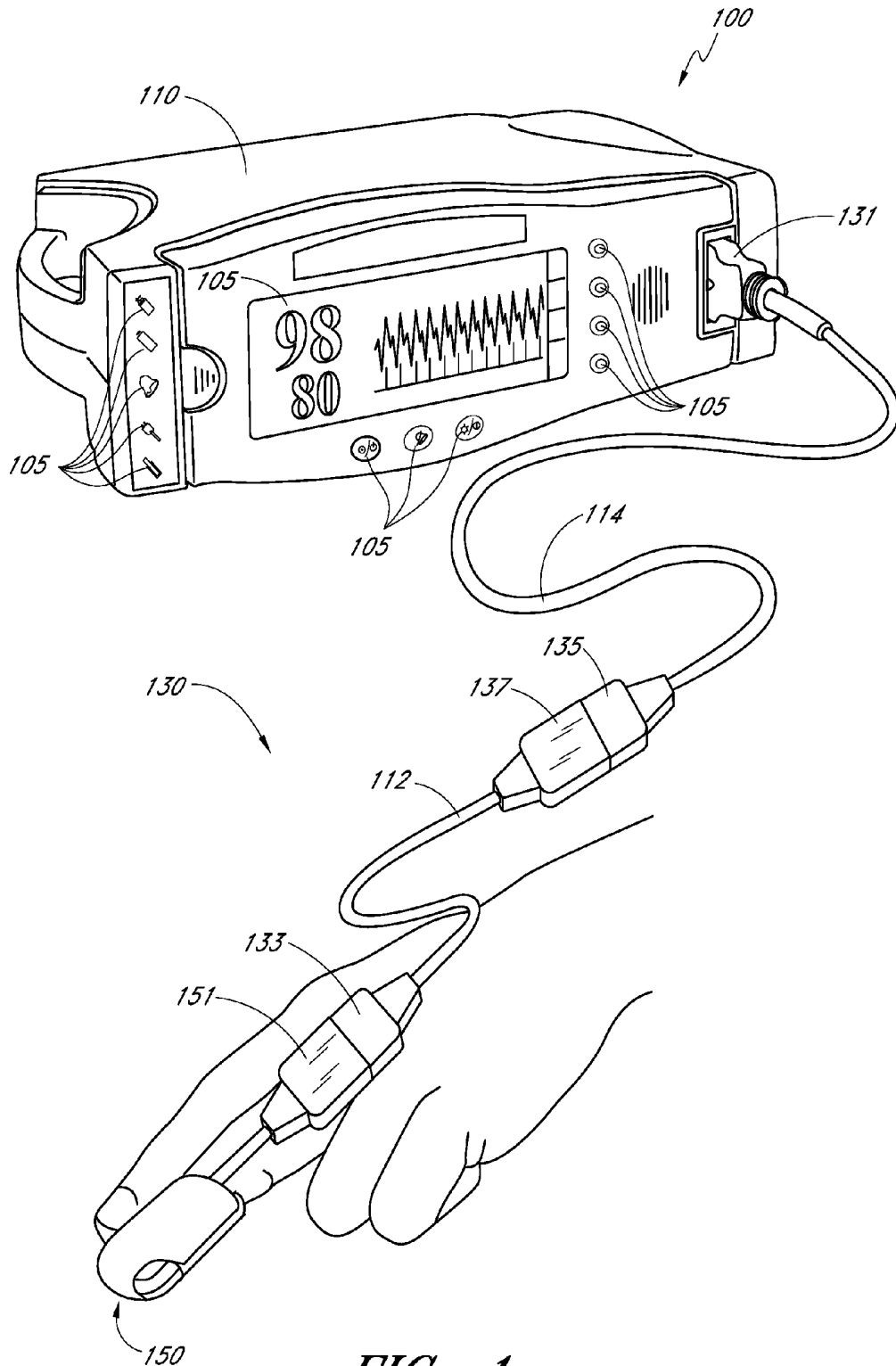

FIG. 1

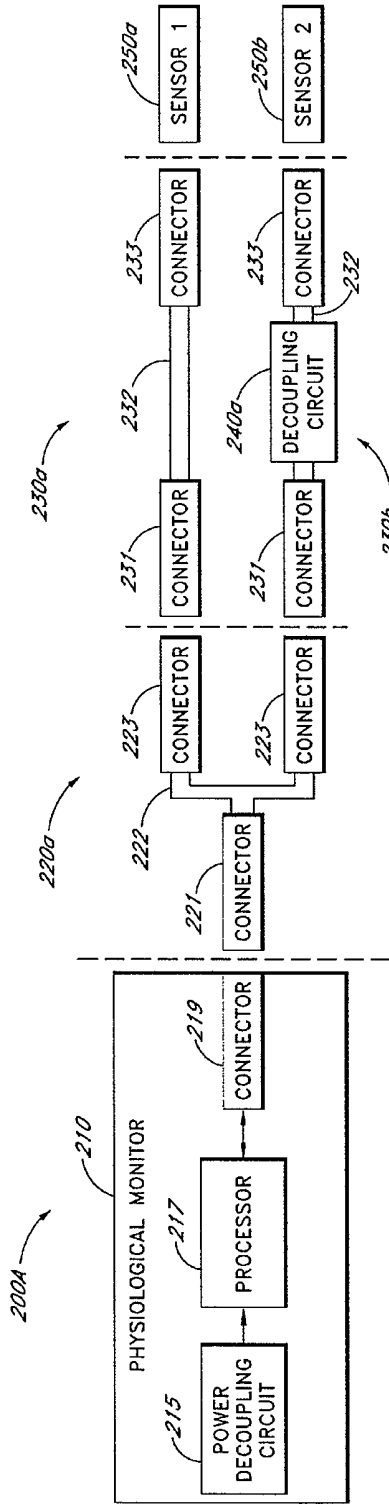

FIG. 2A

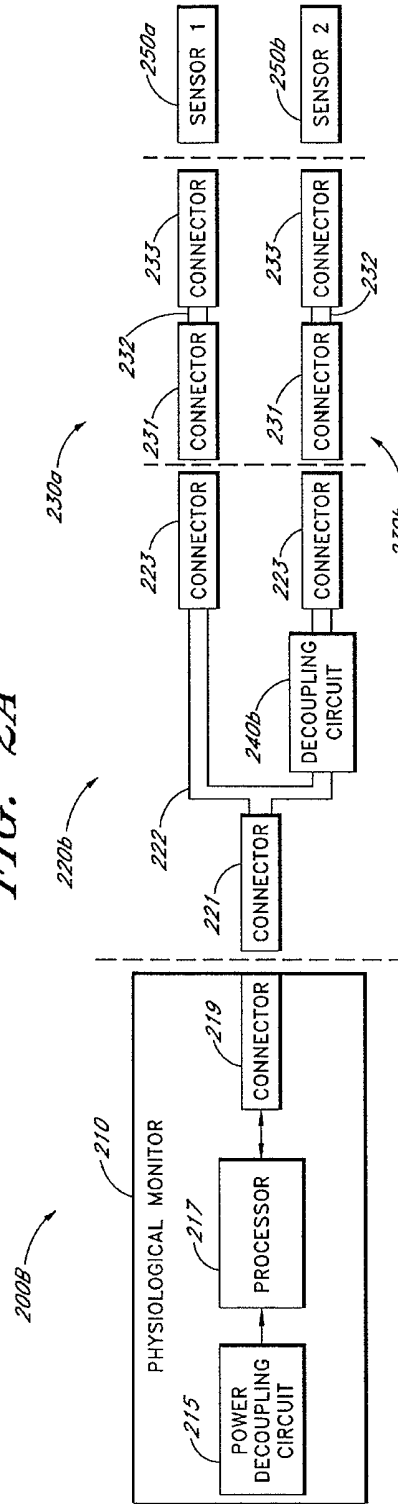

FIG. 2B

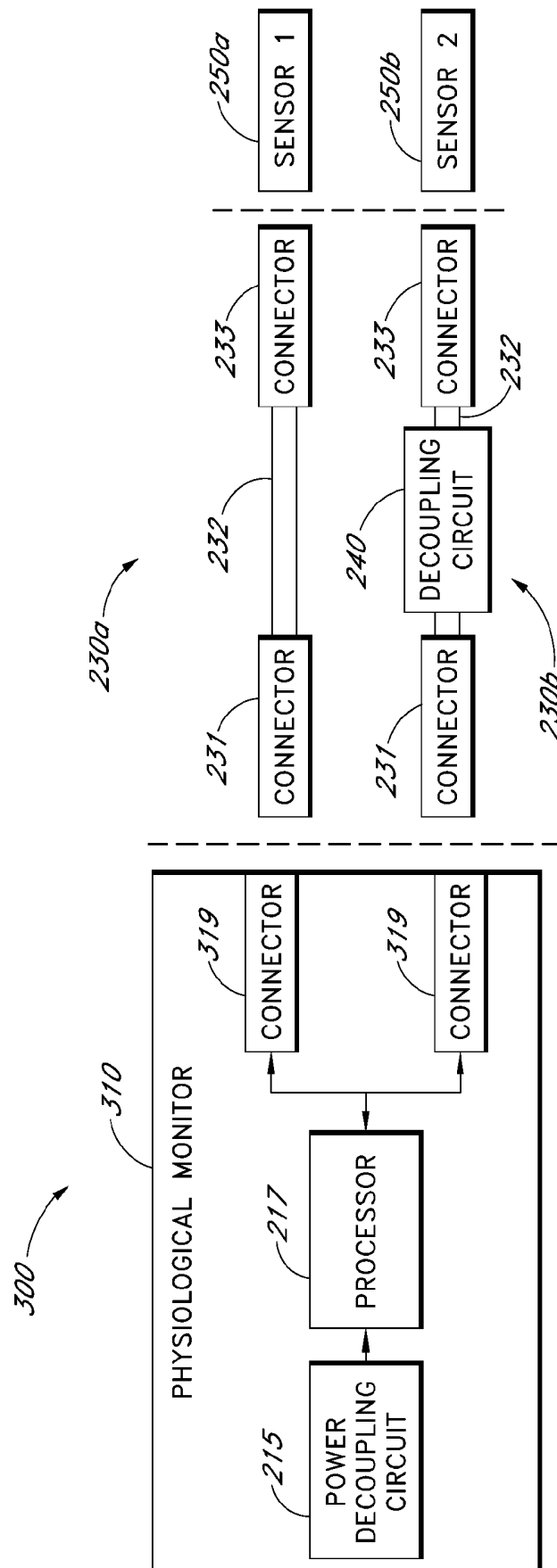

FIG. 3

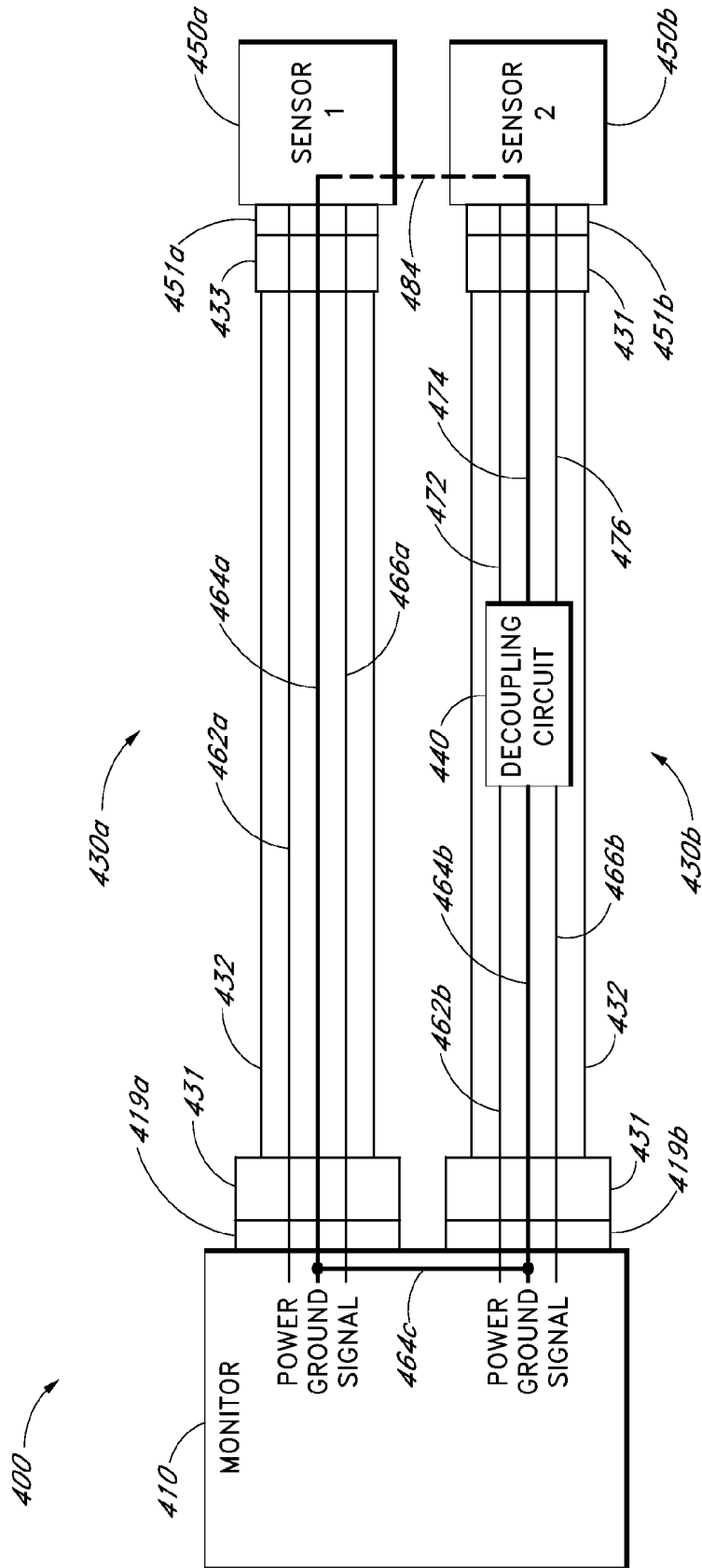

FIG. 4

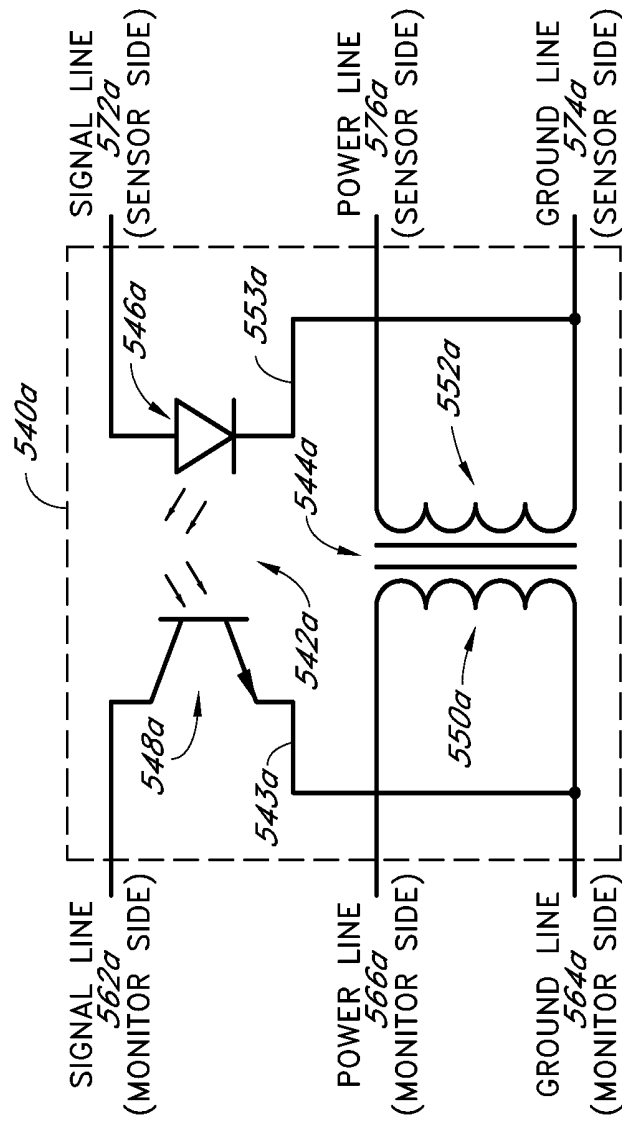

FIG. 5A

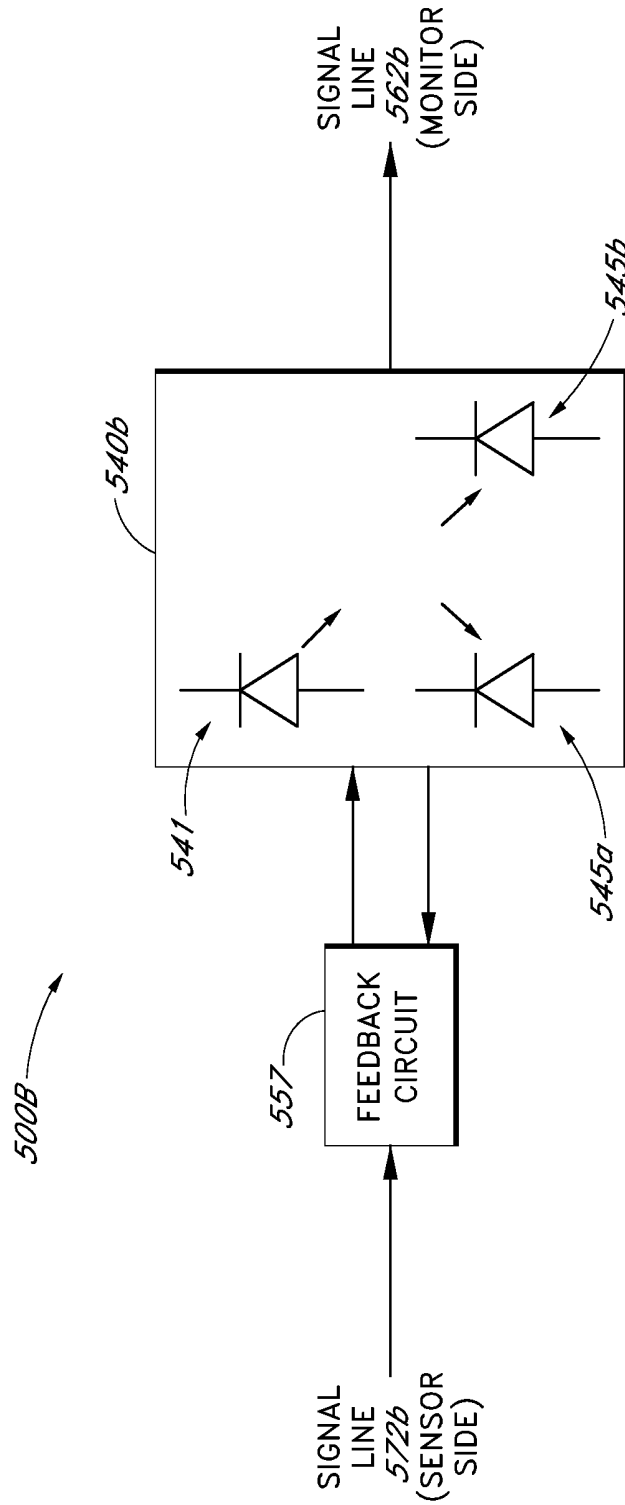

FIG. 5B

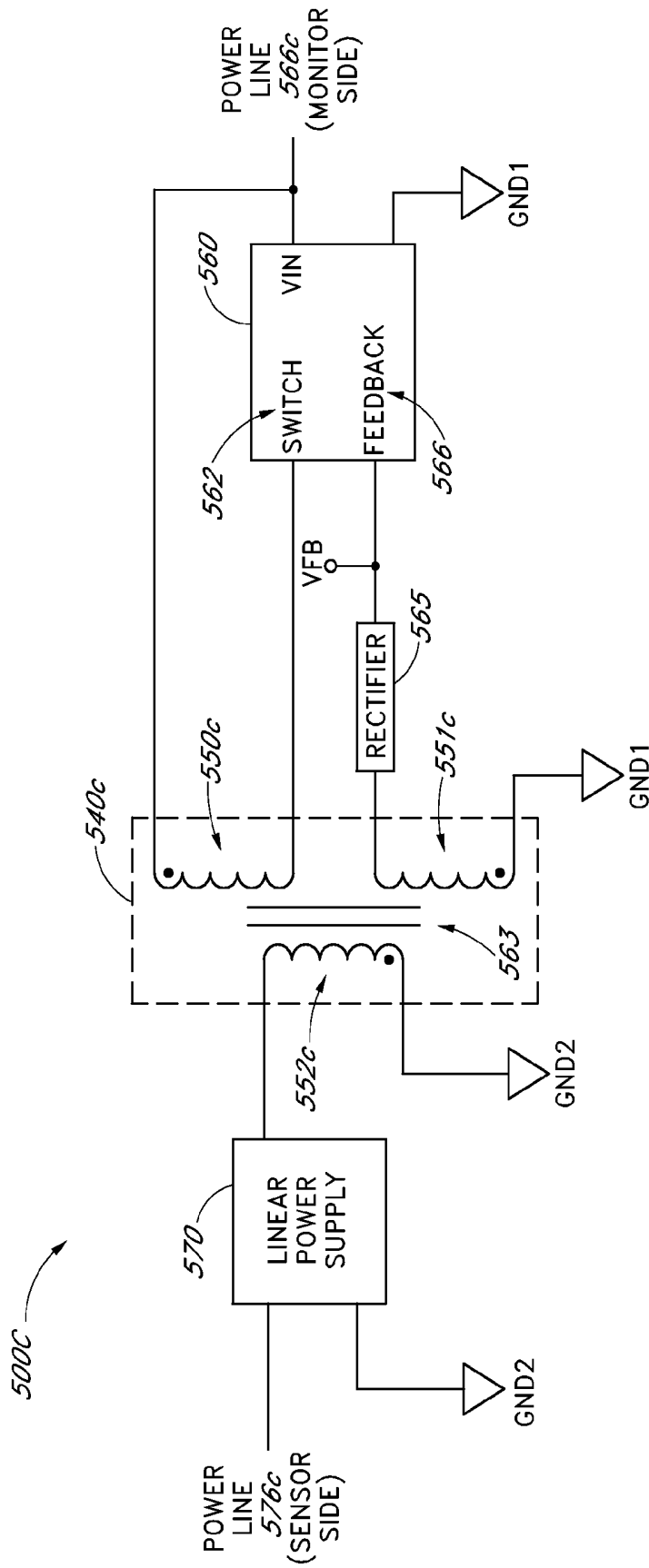

FIG. 5C

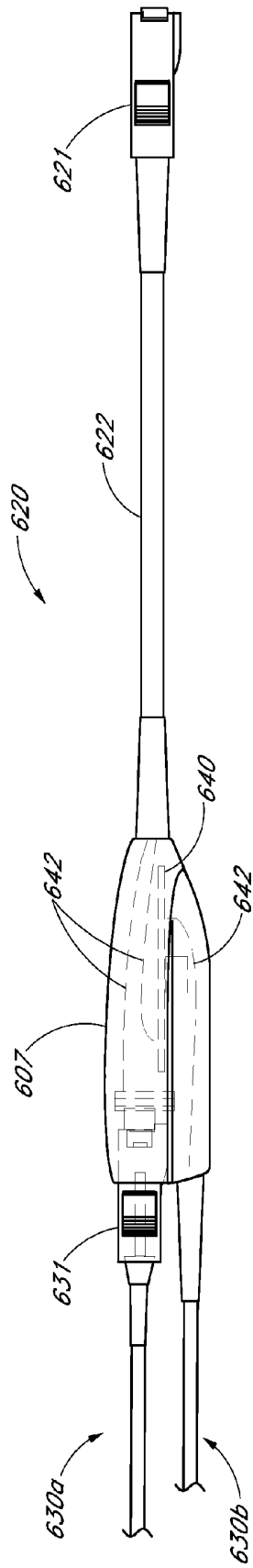

FIG. 6A

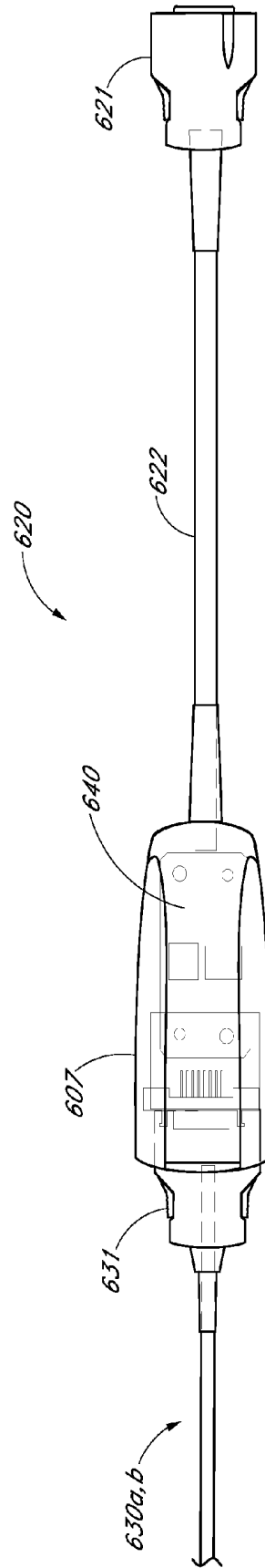

FIG. 6B

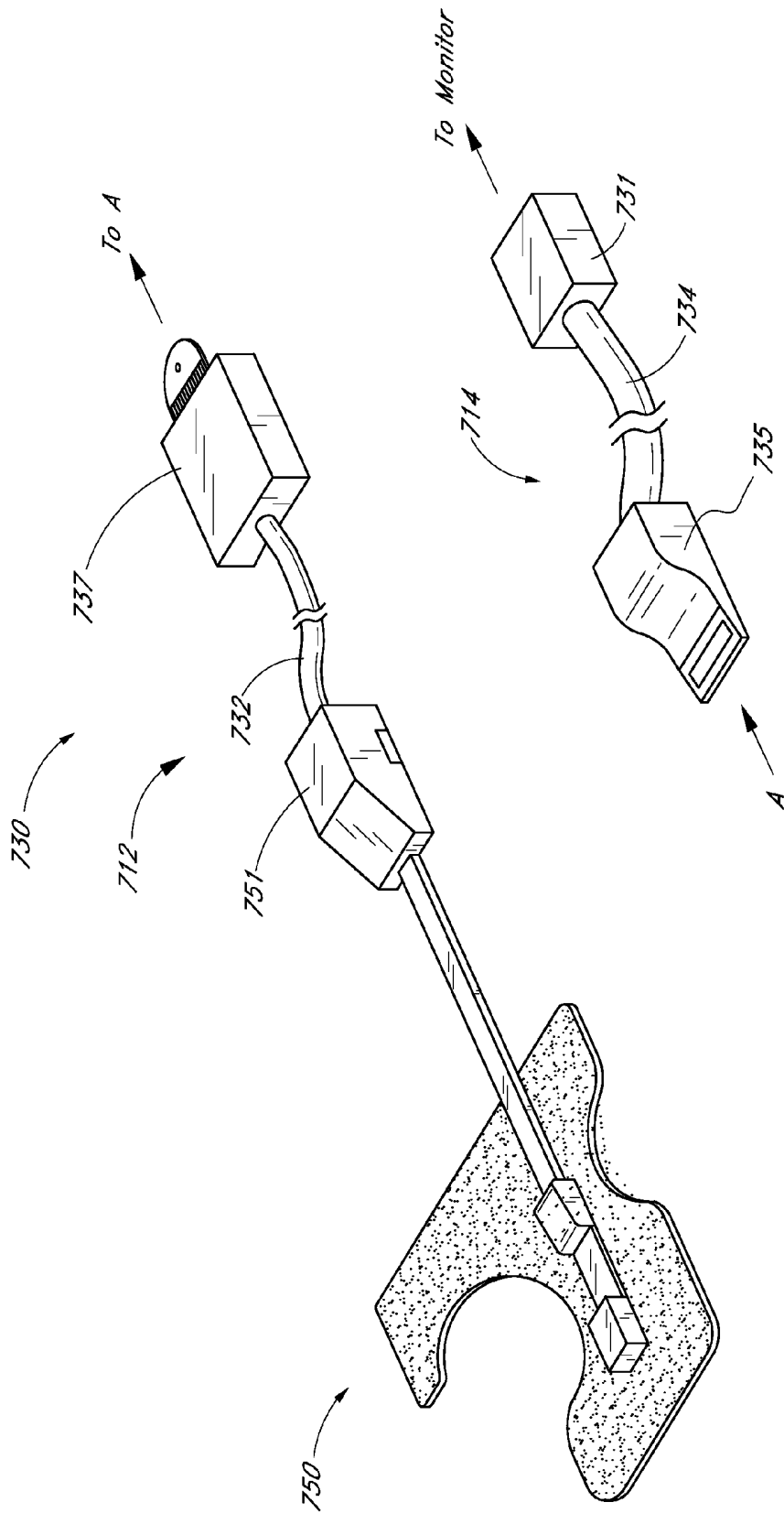

FIG. 7

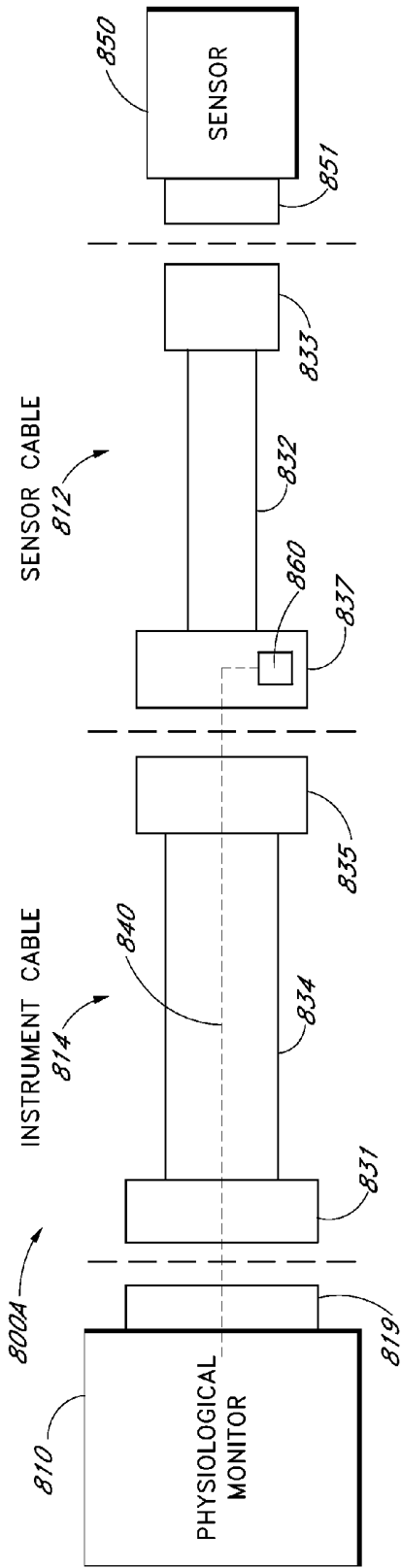

FIG. 8A

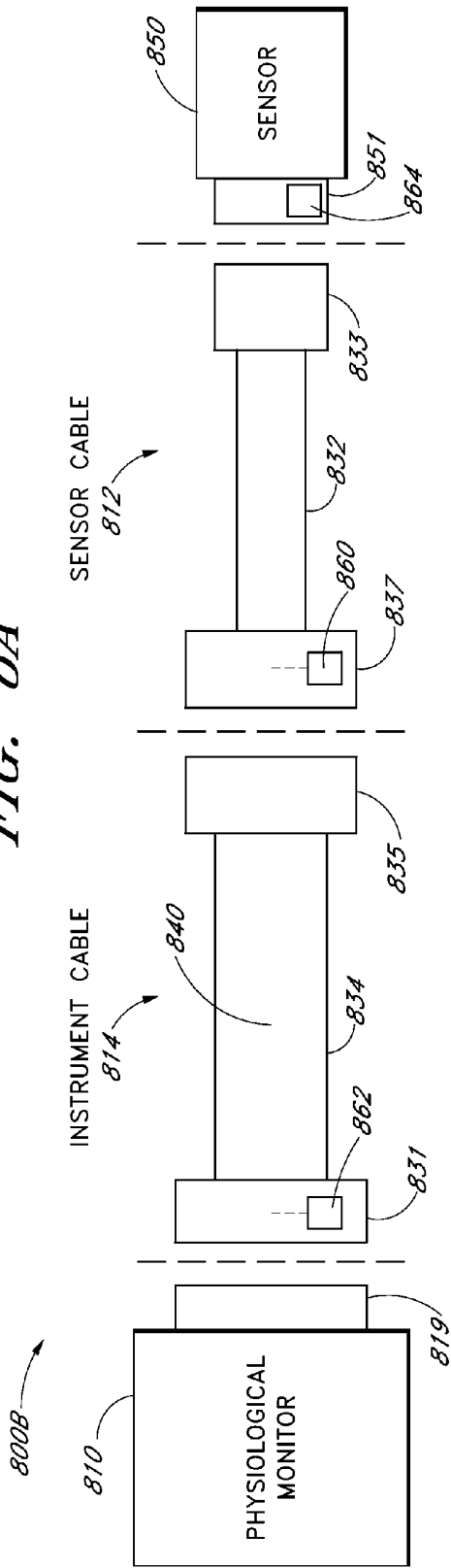

FIG. 8B

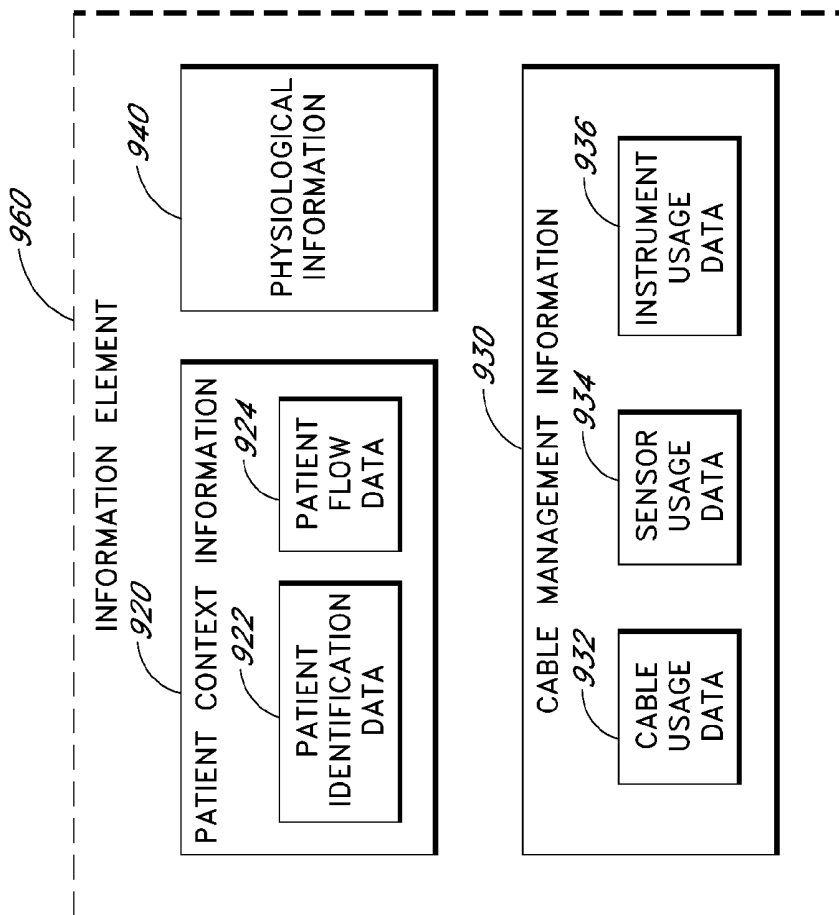

FIG. 9

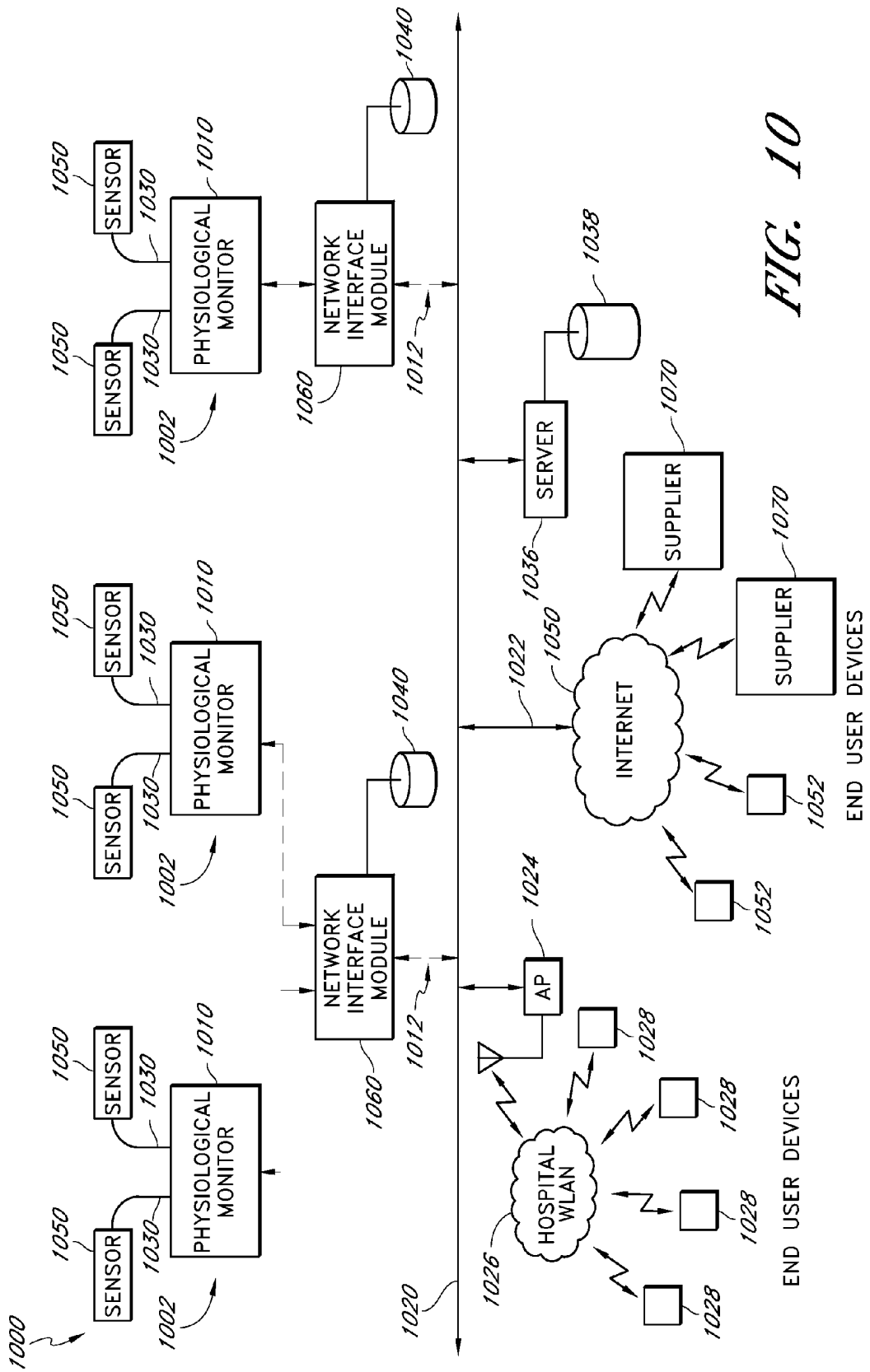

FIG. 10

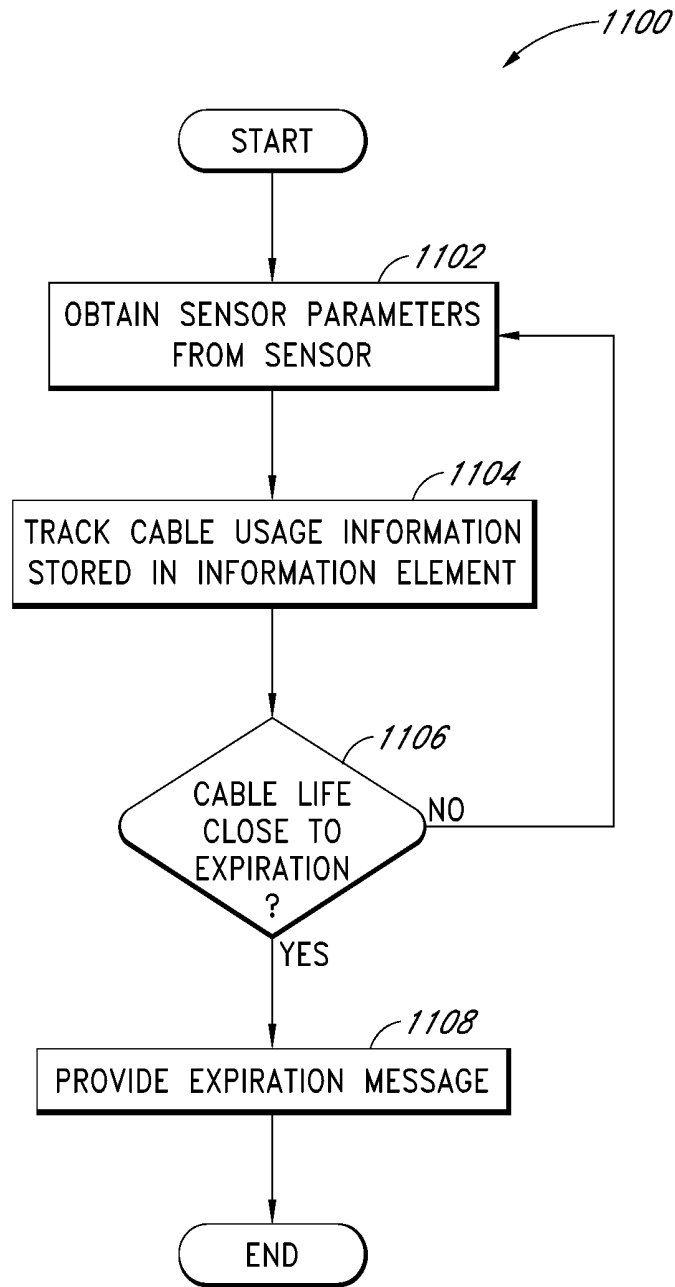

FIG. 11

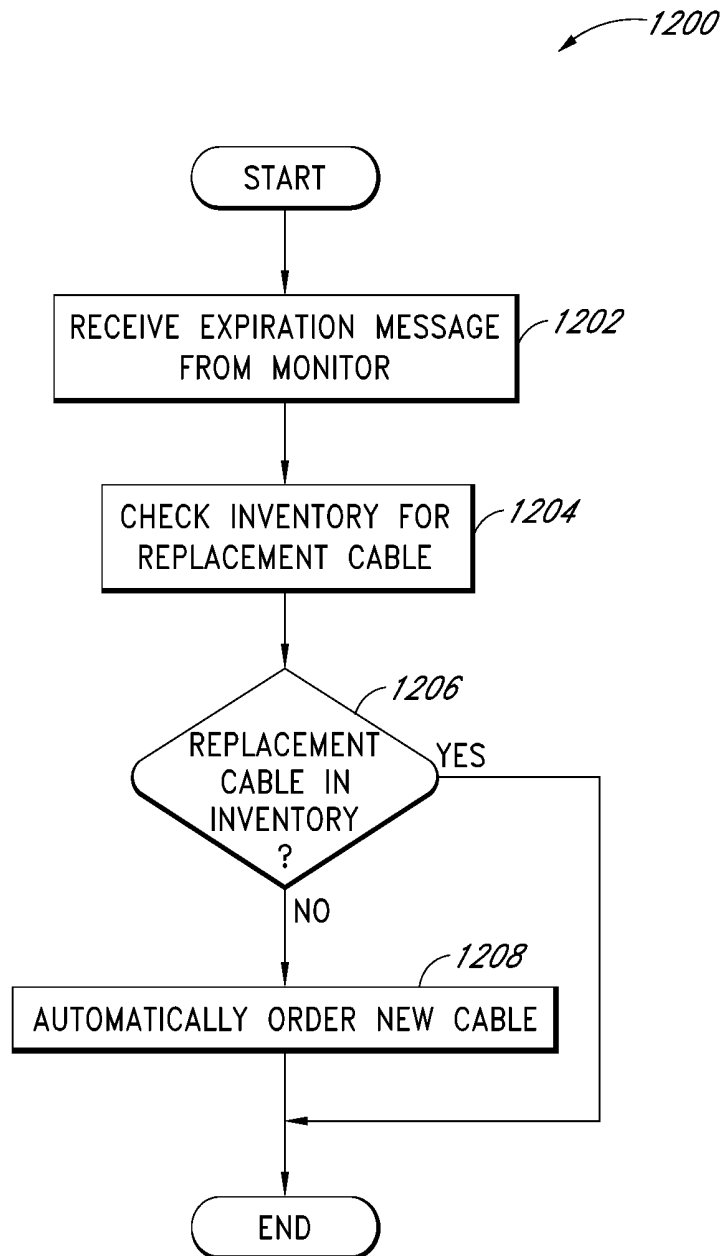

FIG. 12

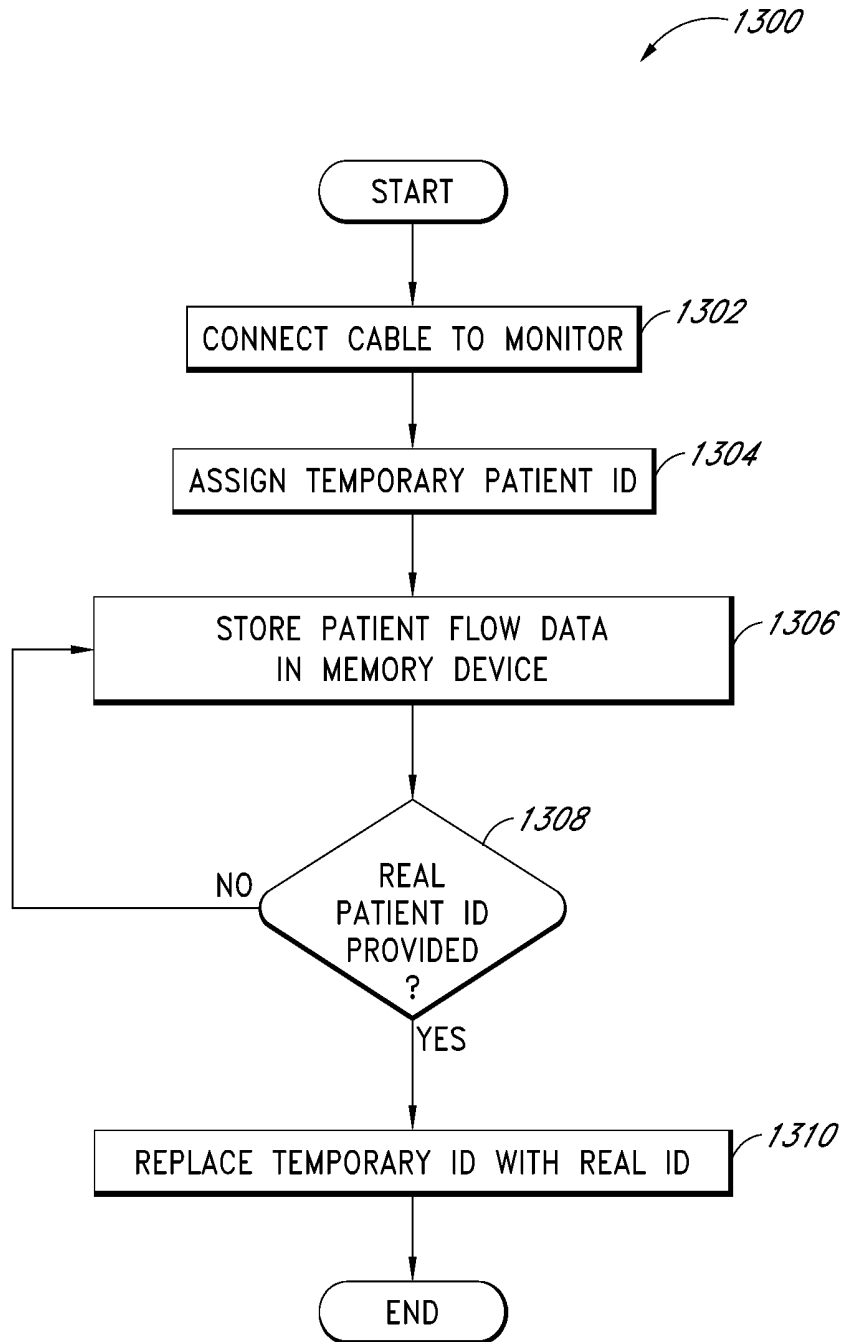

FIG. 13

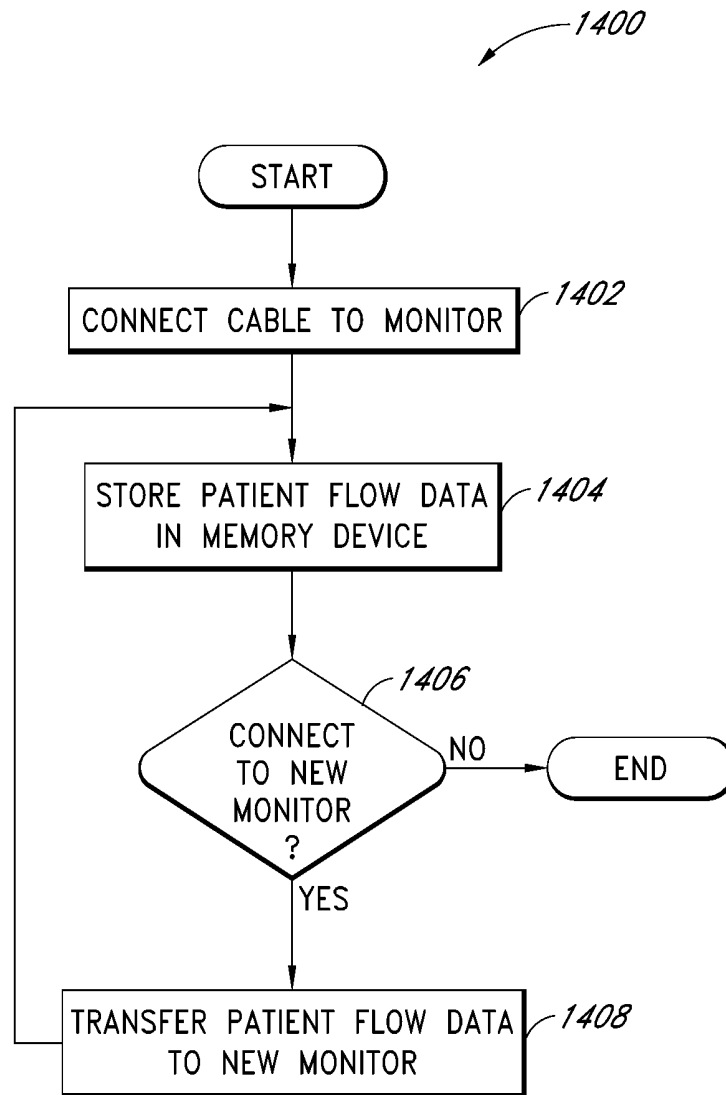

FIG. 14

PULSE OXIMETRY SYSTEM WITH ELECTRICAL DECOUPLING CIRCUITRY

CROSS-REFERENCE TO RELATED APPLICATIONS

The present application claims priority from U.S. Provisional Application No. 61/050,476, titled "Medical Cable Assembly for Reducing the Risk of Electric Shock to a Patient," filed May 5, 2008, which is hereby incorporated by reference in its entirety.

BACKGROUND

Hospitals, nursing homes, and other patient care facilities typically include patient monitoring devices at one or more bedsides in the facility. Patient monitoring devices generally include sensors, processing equipment, and displays for obtaining and analyzing a medical patient's physiological parameters. Physiological parameters include, for example, respiratory rate, oxygen saturation (SpO₂) level, pulse, and blood pressure, among others. Clinicians, including doctors, nurses, and certain other medical personnel, use the physiological parameters obtained from the medical patient to diagnose illnesses and to prescribe treatments. Clinicians also use the physiological parameters to monitor a patient during various clinical situations to determine whether to increase the level of medical care given to the patient.

Many monitoring devices receive physiological signals from one or more sensors, such as pulse oximetry sensors, acoustic sensors, and the like. Medical cables attached to the sensors transmit signals from the sensors to the monitoring device.

SUMMARY

Certain implementations of a pulse oximetry system for reducing the risk of electric shock to a medical patient include a plurality of physiological sensors, where at least one of the physiological sensors has a light emitter that can impinge light on body tissue of a living patient and a detector responsive to the light after attenuation by the body tissue. The body tissue can include pulsating blood. The detector can generate a signal indicative of a physiological characteristic of the living patient. The medical apparatus may also include a splitter cable having a monitor connector that can connect to a physiological monitor, a plurality of sensor connectors that can each connect to one of the physiological sensors, and a plurality of cable sections each disposed between a sensor connector and the monitor connector, where each of the cable sections have one or more electrical conductors. The one or more electrical conductors for at least some of the cable sections may include a power line that can supply power to one or more of the plurality of physiological sensors, a signal line that can transmit the physiological signals from one or more of the physiological sensors to the physiological monitor, and a ground line that can provide an electrical return path for the power line. Further, the splitter cable may also have one or more decoupling circuits in communication with selected ones of the one or more electrical conductors. The one or more decoupling circuits may communicate physiological signals between one or more of the physiological sensors and the physiological monitor. The one or more decoupling circuits can electrically decouple the physiological sensors, such that the one or more decoupling circuits are configured to substantially prevent ground loops from forming in the ground line.

In certain embodiments, a medical apparatus for reducing the risk of electric shock to a medical patient when used with a pulse oximeter includes a plurality of physiological sensors. At least one of the physiological sensors can include a light emitter that can impinge light on body tissue of a living patient, where the body tissue has pulsating blood. The physiological sensor can also include a detector responsive to the light after attenuation by the body tissue, such that the detector can generate a signal indicative of a physiological characteristic of the living patient. The medical apparatus may also include a splitter cable that can connect the plurality of physiological sensors to a physiological monitor. The splitter cable may include a plurality of cable sections that each includes one or more electrical conductors that can interface with one of the physiological sensors. One or more decoupling circuits can be disposed in the splitter cable. The one or more decoupling circuits can be in communication with selected ones of the one or more electrical conductors. The one or more decoupling circuits can communicate physiological signals between one or more of the physiological sensors and the physiological monitor. The one or more decoupling circuits can electrically decouple the physiological sensors.

Various embodiments of a method for reducing the risk of electric shock to a medical patient as used with a pulse oximeter may include providing a plurality of physiological sensors, where at least one of the physiological sensors has a light emitter that can impinge light on body tissue of a medical patient and a detector that can generate a signal indicative of a physiological characteristic of the living patient responsive to the light after attenuation by the body tissue. The method can also include providing a medical cable assembly having one or more electrical conductors that can allow communication between the plurality of physiological sensors and a physiological monitor, such that the medical cable assembly can provide signals representing physiological information of a medical patient from the plurality of physiological sensors to the physiological monitor. Moreover, the method may include electrically decoupling the plurality of physiological sensors using one or more decoupling circuits disposed in the medical cable assembly. The one or more decoupling circuits may be in communication with the plurality of physiological sensors and with the physiological monitor.

For purposes of summarizing the disclosure, certain aspects, advantages and novel features of the inventions have been described herein. It is to be understood that not necessarily all such advantages may be achieved in accordance with any particular embodiment of the inventions disclosed herein. Thus, the inventions disclosed herein may be embodied or carried out in a manner that achieves or optimizes one advantage or group of advantages as taught herein without necessarily achieving other advantages as may be taught or suggested herein.

BRIEF DESCRIPTION OF THE DRAWINGS

Various embodiments will be described hereinafter with reference to the accompanying drawings. These embodiments are illustrated and described by example only, and are not intended to limit the scope of the disclosure. In the drawings, similar elements have similar reference numerals.

FIG. 1 illustrates a perspective view of an embodiment of a physiological monitoring system;

FIGS. 2A and 2B illustrate block diagrams of example physiological monitoring systems having splitter cables;

FIG. 3 illustrates a block diagram of another embodiment of a physiological monitoring system having multiple cables;

FIG. 4 illustrates a block diagram of yet another embodiment of a physiological monitoring system having multiple cables;

FIGS. 5A through 5C illustrate embodiments of decoupling circuits;

FIG. 6A illustrates a side view of an example splitter cable;

FIG. 6B illustrates a bottom view of the example splitter cable of FIG. 6A;

FIG. 7 illustrates a perspective view of an example sensor and cable assembly;

FIGS. 8A and 8B illustrate block diagrams of example cables that include one or more information elements;

FIG. 8C illustrates an embodiment of a circuit for communicating with one or more information elements and a sensor;

FIG. 9 illustrates a block diagram of exemplary forms of data that can be stored in an information element;

FIG. 10 illustrates an embodiment of a physiological monitoring system having multiple networked physiological monitors;

FIGS. 11 and 12 illustrate flowchart diagrams of example cable management processes; and

FIGS. 13 and 14 illustrate flowchart diagrams of example patient context management processes.

DETAILED DESCRIPTION

Multiple sensors are often applied to a medical patient to provide physiological information about the patient to a physiological monitor. Some sensors, including certain optical and acoustic sensors, interface with the monitor using a cable having power, signal, and ground lines or wires. One or more of these lines can pose an electric shock hazard when multiple sensors are attached to the patient. If an electrical potential exists in the ground line, for instance, a ground loop can form in the patient or in the ground line, allowing unwanted current to pass through the patient through the ground line. Power fluctuations or surges, such as from a defibrillator, can potentially harm the patient and damage the monitor or the sensors.

This disclosure describes decoupling circuitry that can be used to prevent or substantially prevent ground loops and other current loops from forming. Using decoupling circuitry in this manner can be referred to as providing sensor isolation, patient isolation, patient protection, sensor decoupling, or the like. Currently-available physiological monitors that connect to one sensor at a time using a single cable may not have this decoupling circuitry. Upgrading these monitors to receive two or more sensors can create the shock hazard described above unless protective circuitry is added to these monitors. For existing single-sensor monitors, adding this circuitry might require a costly upgrade of the monitors internal components. For new single-sensor monitors, the decoupling circuitry could be added during manufacturing. But this approach would be cost-inefficient for buyers who wish to use only one sensor with the device.

Accordingly, in certain embodiments, the decoupling circuitry is provided in a medical cable assembly. The medical cable assembly includes, in some embodiments, a splitter cable that interfaces multiple physiological sensors with a single sensor port on a physiological monitor. Advantageously, in certain embodiments, the medical cable assembly allows multiple sensors to connect to a monitor while reducing the risk of electric shock to a patient.

Turning to FIG. 1, an embodiment of a physiological monitoring system 100 for monitoring a medical patient is shown. The physiological monitoring system 100 includes a physiological monitor 110 coupled with a sensor assembly 150

through a cable 130. The monitor 110 includes various visual indicia and user controls 105 for displaying sensor parameters, alarms, and the like and for receiving user input. The sensor assembly 150 could include any of a variety of physiological sensors. For example, the sensor assembly 150 could include one or more optical sensors that allow the measurement of blood constituents and related parameters, acoustic respiratory sensors, electrocardiograph sensors, and the like.

More generally, the sensor assembly 150 can include one or more sensors that measure one or more of a variety of physiological parameters, including oxygen saturation, carboxyhemoglobin (HbCO), methemoglobin (HbMet), fractional oxygen, total hemoglobin (HbT/SpHb), pulse rate, perfusion index electrical heart activity via electrocardiography, and blood pressure. Other examples of physiological parameters that may be measured include respiratory rate, inspiratory time, expiratory time, inspiration-to-expiration ratio, inspiratory flow, expiratory flow, tidal volume, end-tidal CO₂ (ETCO₂), CO₂, minute volume, apnea duration, breath sounds, rales, rhonchi, stridor, changes in breath sounds such as decreased volume or change in airflow, heart rate, heart sounds (e.g., S1, S2, S3, S4, and murmurs), and changes in heart sounds such as normal to murmur or split heart sounds indicating fluid overload.

In some embodiments, the sensor assembly 150 can be an optical sensor having one or more emitters, such as light emitting diodes. The emitters may emit multiple wavelengths of light that impinge on body tissue of a living patient, such as a finger, foot, ear, or the like. The emitters may also emit non-visible radiation. The sensor assembly 150 may further include one or more detectors that can receive light attenuated by the body tissue of the patient. The detectors can generate physiological signals responsive to the detected light. The sensor assembly 150 can provide these physiological signals to the monitor 110 for processing to determine one or more physiological parameters, such as certain of the parameters described above. An example of such a sensor assembly 150 is described in U.S. Publication No. 2006/0211924, filed Mar. 1, 2006, titled "Multiple Wavelength Sensor Emitters," the disclosure of which is hereby incorporated by reference in its entirety.

The cable 130 is connected to the sensor assembly 150 and to the monitor 110. In some embodiments, the cable 130 includes two or more cables or cable assemblies, although it should be noted that the cable 130 can also be a single cable 130. In the illustrated embodiment, the cable 130 includes a sensor cable 112 and an instrument cable 114. The sensor cable 114 is connected directly to the sensor assembly 150 through connectors 133, 151, and the instrument cable 114 is connected directly to the monitor 110 through a connector 131. The sensor cable 112 is connected to the instrument cable 114 through connectors 135, 137.

In certain embodiments, the sensor cable 112 is a lightweight, flexible cable used for a single medical patient and disposed of after use with that patient. In contrast, the instrument cable 112 of certain embodiments is used for multiple patients and may be more durable than the sensor cable 112. For example, the instrument cable 112 may be thicker, stiffer, or heavier than the sensor cable 112. Advantageously, in certain embodiments, the lightweight, flexible characteristics of the sensor cable 112 make the sensor cable 112 more comfortable to attach to a patient. A patient with a sensor assembly 150 attached to her finger, for instance, could more easily move her hand with a lightweight sensor cable 112 attached to the sensor assembly 150. However, if some or all of the cable 130 were lightweight and flexible, it might be less durable. Hence, a portion of the cable 130 (e.g., the instru-

ment cable 114) is stronger and more durable, yet potentially heavier and less flexible. The instrument cable 114 could therefore be used for multiple patients, while the sensor cable 112 might be used for fewer patients, such as a single patient.

While the physiological monitor 110 of FIG. 1 is shown connecting to a single sensor assembly 150, it may be advantageous in certain embodiments to connect to multiple sensors, such as sensors that monitor different physiological parameters. For instance, the physiological monitor 110 could connect to a pulse oximetry sensor and an acoustic sensor that measures respiratory rate, heart sounds, and related parameters. One way to provide multiple sensor functionality to the physiological monitor 110 is to provide a splitter cable between the monitor and the cable 130 (see FIGS. 2 and 6). A splitter cable reduces or eliminates a need to build a second cable port into the chassis of the physiological monitor 110 to accommodate a second cable 130. Consequently, using a splitter cable can reduce costs. Moreover, using a splitter cable can reduce cross-talk noise between signal lines from the sensors.

However, as described above, upgrading the physiological monitor 110 to receive input from multiple sensors using a splitter cable or the like can create electrical shock hazards to the patient due to the possibility of conductive paths forming through the sensors, cabling, and the patient. For example, if an acoustic sensor is placed on the chest and a defibrillator paddle touches the acoustic sensor, a surge of current could discharge through a conductive path formed in the patient between the acoustic sensor and a second sensor, and through the physiological monitor 110. This current surge could injure the patient and damage the monitor 110.

Consequently, various embodiments of the cable 130 or an attached splitter cable can include one or more decoupling circuits (not shown) for reducing the risk of electric shock to the patient. Each decoupling circuit can electrically decouple the sensor assembly 150 from the monitor 110 or can decouple multiple sensor assemblies 150. In addition to having its ordinary meaning, electrical decoupling can mean breaking a conductive path (e.g., by providing a dielectric between two conductors) or increasing the resistance between conductors. Electrical decoupling can be accomplished using transformers and/or optocouplers, as described below. The electrical decoupling of the decoupling circuit can prevent or reduce harmful current surges from harming the patient. Example decoupling circuits are described below with respect to FIGS. 2 through 6.

In addition to including decoupling circuitry in the cable 130 or in an attached splitter cable, it may be desirable to include other circuitry in the cable 130 or splitter cable. For example, the cable 130, a splitter cable, and/or the sensor assembly 150 may include one or more information elements (not shown), which can be memory devices such as EEPROMs or the like. In one embodiment, the information element stores cable management information, patient context information, and/or physiological information. Example information elements are described below with respect to FIGS. 6 through 14.

FIGS. 2A and 2B illustrate embodiments of physiological monitoring systems 200A, 200B interfacing with multiple sensor assemblies 250. The physiological monitoring systems 200A, 200B each include a physiological monitor 210, a splitter cable 220, two cables 230, and two sensor assemblies 250. The physiological monitoring systems 200A, 200B may include all of the features of the physiological monitoring system 100 described above.

In the physiological monitoring system 200A of FIG. 2A, a patient decoupling circuit 240a is provided in one of the

cables 230b. In the physiological monitoring system 200B of FIG. 2B, the patient decoupling circuit 240b is provided in the splitter cable 220b. These patient decoupling circuits 240a, 240b can reduce or prevent ground loops from forming in the patient and/or in the physiological monitoring system 200. Although not shown, a decoupling circuit could instead be provided in one or both of the sensor assemblies 250.

The physiological monitor 210 processes and outputs physiological information received from sensors included in the sensor assemblies 250a, 250b. The physiological monitor 210 of certain embodiments includes a power decoupling circuit 215, a processing board 217, and a connector 219. The power decoupling circuit 215 may be a transformer or the like that decouples power (e.g., AC electrical power) received from a power source (such as an electrical outlet) and the circuitry of the physiological monitor 210. The power decoupling circuit 215 prevents or substantially prevents current spikes from damaging the other components of the physiological monitor 210 or the patient. In embodiments where the physiological monitor 210 receives power from another source, such as batteries, the power decoupling circuit 215 may not be included.

The processor 217 of certain embodiments is a microprocessor, digital signal processor, a combination of the same, or the like. The processor 217 receives power from the power decoupling circuit 215. In some implementations the processor 217 processes physiological signals received from the sensors 250 and outputs the processed signals to a display, storage device, or the like. In addition, the processor 217 may communicate with an information element (e.g., a memory device) included in a cable or sensor. Information elements are discussed in greater detail below with respect to FIGS. 6 through 14.

The connector 219 includes a physical interface for connecting a cable assembly to the physiological monitor 210. In the embodiment shown in FIGS. 2A and 2B, a single connector 219 is provided. Additional connectors 219 may also be included in some implementations. One embodiment of a physiological monitor having additional connectors 219 is described below with respect to FIG. 3.

The splitter cable 220 is provided in some embodiments to enable the physiological monitor 210 having one connector 219 to interface with multiple sensors 250. The splitter cable 220 interfaces with the connector 219 through a monitor connector 221 in the splitter cable 220. In the depicted embodiment, where the splitter cable 220 interfaces with two sensors 250, cable sections 222 of the splitter cable 220, which branches into two sections generally forming a “Y” shape or the like. Thus, the splitter cable 220 can be a Y cable or the like. While the splitter cable 220 is shown forming a “Y” shape, other configurations and shapes of the splitter cable 220 may be used. For example, the splitter cable 220 could branch into more than two cable sections 222 to interface with more than two sensors 250.

The cable sections 222 are shown connected to the monitor connector 221 and two cable connectors 223. In some embodiments, the cable sections 222 branch into more than two parts and connect to more than two cable connectors 223. In addition, in some embodiments the splitter cable 220 couples directly to two or more sensors 250.

Some embodiments of the splitter cable 220 include one or more lines, conductors, or wires per cable connector 223. One line might be provided, for example, to interface with one or more electrocardiograph (ECG) sensors. Two or three lines might be provided per cable connector 223, for example, to interface with an optical or acoustic sensor. For instance, three lines might be provided, including a power line, a signal

line, and a ground line (see FIGS. 4 and 5). The power line powers the sensor 250, the signal line receives signals from the sensor 250, and the ground line acts as an electrical return path for the power and/or signal lines. In some embodiments, one or more of the lines coming from one sensor 250a are placed at a predetermined distance from one or more of the lines coming from another sensor 250b to reduce cross-talk interference between the sensors 250. One or more electromagnetic shielding and/or insulating layers may also be provided to help reduce cross-talk. Lines from different sensors may merge into a shared line that connects electrically to the monitor 210, and some form of multiplexing might be used to allow the different sensors to communicate along the shared lines.

The cables 230a, 230b interface with the splitter cable 220 in the depicted embodiment through cable connectors 231. In certain embodiments, each cable 230 also includes a cable section 232 and a sensor connector 233 that connects to a sensor 250. The cable section 232 in some implementations includes one or more lines or wires for communicating with the sensor 250. For example, a power line, sensor line, and ground line may be provided that correspond to the power line, sensor line, and ground line in the example splitter cable 220 described above.

In an embodiment, one of the cables 230 includes the decoupling circuit 240a. In FIG. 2A, for example, the decoupling circuit 240a is shown in the cable section 232 of the cable 230b. The decoupling circuit 240a may also be placed in the cable connector 231 or the sensor connector 233, or in a combination of one or more of the connectors 231, 233 and/or the cable section 232. In another exemplary embodiment, FIG. 2B shows that the decoupling circuit 240b can be included in one of the cable sections 222 of the splitter cable 220b. The decoupling circuit 240b may also be placed in the monitor connector 221 or the sensor connector 223, or in a combination of the cable sections 222 and/or one or more of the connectors 221, 223.

Multiple decoupling circuits 240 may also be provided in one or more of the cables 230 and/or in the splitter cable 220 in other embodiments. In particular, in one embodiment when N cables 230 are provided (or one splitter cable 220 with N connectors 223), N-1 decoupling circuits 240 are provided in N-1 of the cables 230 or in the various sections of the splitter cable 220.

The decoupling circuit 240 of certain embodiments electrically decouples a sensor 250 from the physiological monitor 210. In addition, the decoupling circuit 240 can electrically decouple one sensor (e.g., the sensor 250b) from another sensor (e.g., the sensor 250a) in certain embodiments. The decoupling circuit 240 can be a transformer, an optocoupler, a DC-DC converter, a switched-mode converter, or the like or a combination of the foregoing. In addition, the decoupling circuit 240 can include one or more optical fibers. An optical fiber may be used in place of the signal line, for example. More detailed embodiments of the decoupling circuit 240 are described below with respect to FIGS. 4 and 5.

The sensors 250 connect to the sensor connectors 233 of the cables 230. In an embodiment, one of the sensors 250 is an optical sensor, such as a multiple wavelength oximetry sensor. The other sensor 250 in one embodiment is an acoustic sensor. In addition, the sensor 250 may be an acoustic sensor that also monitors ECG signals, such as is described in U.S. Provisional Application No. 60/893,853, titled "Multi-parameter Physiological Monitor," and filed Mar. 8, 2007, the disclosure of which is hereby incorporated by reference in its entirety. Many other types of sensors 250 can also be used to monitor one or more physiological parameters.

FIG. 3 illustrates another embodiment of a physiological monitoring system 300 having multiple cables 230. The physiological monitoring system 300 may have certain of the features of the physiological monitoring systems 100, 200 described above. For example, like the physiological monitoring system 200 described above, the physiological monitoring system 300 includes a physiological monitor 310, two cables 230, and two sensors 250. In the physiological monitoring system 300, a decoupling circuit 240 is provided in one of the cables 230b.

Like the physiological monitor 210, the physiological monitor 310 includes a power decoupling circuit 215 and a processor 217. Unlike the physiological monitor 210, however, the physiological monitor 310 includes two connectors 319 for interfacing directly with two cables without using a splitter cable. To save costs for users who will use only one sensor 250 with the physiological monitor 310, a decoupling circuit 240 is not provided in the physiological monitor 310. Instead, the decoupling circuit 240 can be provided in a separate cable 230b that can be used with the physiological monitor 310.

For example, a user might use one cable 230a and sensor 250a at a time with the physiological monitor 310. Since only one sensor 250a is being used, ground or other current loops are less likely to form in the patient. If the user later wishes to use additional sensors 250, the user can obtain a cable 230b having the decoupling circuit 240. Using the cable 230b can beneficially allow the user to continue using the physiological monitor 310 without performing an upgrade to the physiological monitor's 310 internal components.

FIG. 4 illustrates another embodiment of a physiological monitoring system 400 having multiple cables 430. The physiological monitoring system 400 may have certain of the features of the physiological monitoring systems 100, 200, 300 described above. For example, like the physiological monitoring systems described above, the physiological monitoring system 400 includes a physiological monitor 410, two cables 430, and two sensors 450. The features described with respect to FIG. 4 may also be applied to a monitoring system having a splitter cable instead of multiple cables.

In the depicted embodiment, the cables 430 are shown connected to the physiological monitor 410 and to the sensors 450. Connectors 419 in the physiological monitor 410 couple with connectors 431 of the cables 430, and connectors 433 of the cables couple with connectors 451 of the sensors 450. A cable section 432 extends between the connectors 431, 433 of each cable.

The cable 430a includes a power line 462a, a ground line 464a, and a signal line 466a extending from the connector 431 to the connector 433. These lines form electrical connections with corresponding power, ground, and signal lines in the connector 419a of the physiological monitor 410 and in the connector 451a of the sensor 450a. Likewise, the cable 430b includes a power line 462b, a ground line 464b, and a signal line 466b. These lines form electrical connections with corresponding power, ground, and signal lines in the connector 419b of the physiological monitor 410. In addition, these lines extend from the connector 431 to a decoupling circuit 440. A power line 472, ground line 474, and signal line 476 extend from the decoupling circuit 440 to the connector 431 to form electrical connections with corresponding power, signal, and ground lines in the connector 451b of the sensor 450b. The cable section 432 can also include one or more electrical insulation and shielding layers, materials, or fillers. Although not shown, one or more of the cables 430a, 430b may also include one or more communications lines for communicating with information elements.

In the depicted embodiment, the ground line **464a** is connected to the ground line **464b** in the physiological monitor **410** through line **464c**. When both sensors **450** are placed on a patient, the ground lines **464a** and **474b** may also be in electrical communication through the patient, as illustrated by the dashed line **484**. If the decoupling circuit **440** were not present in one of the cables **430**, a ground loop might be formed along the lines **464a**, **464b**, **464c**, **474**, and **484** (illustrated with bold lines) due to, for example, a difference in electrical potential in the lines **464a**, **464b**, **464c**, and **474**. While not shown in bold, current loops might also form in some cases among the power lines **462a**, **462b**, **472** or the signal lines **466a**, **466b**, **476**.

Advantageously, in certain embodiments, the decoupling circuit **440** reduces the risk of a ground or other loop forming by decoupling one or more of the power lines **462b**, **472**, the signal lines **464b**, **474**, or the ground lines **464b**, **474**. More detailed embodiments illustrating how the decoupling circuit **440** could decouple one or more lines is described below with respect to FIGS. **5A** through **5C** and FIG. **8C**.

While only one decoupling circuit is shown, in other embodiments, multiple decoupling circuits may be provided in one cable **430**. For instance, a first decoupling circuit could be connected to the power line **462b** and the ground line **466b**, and a second decoupling circuit could be connected to the signal line **464b** and to the ground line **466b**. In addition, in certain embodiments, there may be a decoupling circuit in each cable **430a**, **430b**.

FIG. **5A** illustrates a more detailed embodiment of a decoupling circuit **540a** suitable for use with any of the embodiments discussed herein. The decoupling circuit **540a** may include all the features of the decoupling circuits **240**, **340**, and **440** described above. For example, the decoupling circuit **540a** may be included in a medical cable assembly, such as a splitter cable, medical cable, or the like, or in a sensor assembly. The decoupling circuit **540a** can decouple electrical signals and prevent or reduce ground or other conducting loops from forming and can protect against current surges in a multi-sensor physiological monitoring system.

The decoupling circuit **540a** is shown within dashed lines. The decoupling circuit **540a** of various embodiments receives a signal line **562a**, a power line **566a**, and a ground line **564a**. These lines can be connected to a physiological monitor (not shown). In addition, the decoupling circuit **540a** receives a signal line **572a**, a power line **576a**, and a ground line **574a**, which may be connected to a sensor (not shown).

In an embodiment, the power line **566a** provides power from a physiological monitor to the decoupling circuit **540a**, which provides the power to the sensor through the power line **576a**. The signal line **572a** provides a physiological signal from the sensor to the decoupling circuit **540a**, which provides the physiological signal to the monitor through the signal line **562a**. The ground lines **564a** and **574a** act as return paths for their respective signal and power lines **562a**, **566a**, **572a**, **576a**.

The decoupling circuit **540a**, in some implementations, includes an optocoupler **542a** and a transformer **544a**. The optocoupler **542a** receives physiological signals from the sensor line **572a** and provides the signals to the sensor line **562a** optically using, for example, a photodiode **546a** and a phototransistor **548a**. Because the signals are transmitted optically, in certain embodiments there is no electrical contact between the signal lines **562a**, **572a**. Similarly, the transformer **544a** provides power from the power line **566a** to the power line **576a** without electrical contact between the lines **566a**, **576a**. Through mutual inductance, electromagnetic energy is transferred from one winding **550a** of the trans-

former **544a** to another winding **552a**. Because the signals are transmitted using mutual inductance, there is no electrical contact between the power lines **566a**, **576a**.

In certain embodiments, because the power lines **566a**, **576a** and signal lines **562a**, **572a** are electrically decoupled, the ground lines **564a**, **574a** can also be electrically decoupled. As shown, a ground line **543a** of the optocoupler **542a** on the monitor side connects to the ground line **564a**, and a ground line **553a** of the optocoupler **542a** on the sensor side connects to the ground line **574a**. As a result, the risk of ground loops forming in the patient may be reduced or eliminated.

Many other configurations of the decoupling circuit **540a** may be employed. For instance, a second optocoupler **542a** may be used in place of the transformer **544a**, or a second transformer **544a** may be used in place of the optocoupler **542a**. In addition, some forms of DC-DC converters or switched mode converters may be used in place of either the optocoupler **542a** or the transformer **544a**. Alternatively, one or more optical fibers may be used.

Moreover, one or more optical fibers can be used instead of the optocoupler **542a** or the transformer **544a**. Because the optical fibers transmit optical, rather than electrical signals, using optical fibers in certain embodiments beneficially reduces the likelihood of ground loops forming in the patient. In one example embodiment, the optocoupler **542a** in FIG. **5A** is replaced with an optical fiber, but the transformer **544a** is still included in the decoupling circuit **540a**. The optical fiber allows signals to be transmitted through the signal line while preventing current from passing through the signal line. In addition, if optical fibers are used for the signal lines of multiple sensors, the optical fibers can also reduce cross-talk interference among the signal lines.

FIG. **5B** illustrates an embodiment of a circuit **500B** that includes a decoupling circuit **540b**. The decoupling circuit **540b** may include all the features of the decoupling circuits **240**, **340**, and **440** described above. For example, the decoupling circuit **540b** may be included in a medical cable assembly, such as a splitter cable, medical cable, or the like, or in a sensor assembly.

The decoupling circuit **540b** is shown decoupling a signal line **562b** connected to a monitor from a signal line **572b** connected to a sensor. In the depicted embodiment, the decoupling circuit **540b** is an analog optocoupler. The decoupling circuit **540b** includes a transmitting photodiode **541** and two receiving photodiodes **545a**, **545b** for feedback control.

The transmitting photodiode **541** receives physiological signals from the signal line **572b** via a feedback circuit **557** (described below). The transmitting photodiode **541** transmits the physiological signals to both of the receiving photodiodes **545a**, **545b**. The receiving photodiode **545b** transmits the signals it receives from the transmitting photodiode **541** to the monitor via signal line **562b**. The receiving photodiode **545a** transmits the signals it receives to a feedback circuit **557**.

Many diodes are inherently unstable due to nonlinearity and drift characteristics of the diodes. As a result of such instability, the signal produced by the transmitting photodiode **541** may not correspond to the signal provided by the signal line **572b** from the sensor. The receiving diode **545a** can therefore be used as a feedback diode to provide a received signal to the feedback circuit **557**.

The feedback circuit **557** can include an amplifier or the like that adjusts its output provided to the transmitting photodiode **541** based at least partly on a difference between the signal of the transmitting photodiode **541** and the receiving

diode **545a**. Thus, the feedback circuit **557** can correct for errors in the transmitted signal via feedback from the feedback or receiving diode **545a**.

FIG. **5C** illustrates another embodiment of a circuit **500C** that includes a decoupling circuit **540c**. The decoupling circuit **540c** may include all the features of the decoupling circuits **240**, **340**, and **440** described above. For example, the decoupling circuit **540c** may be included in a medical cable assembly, such as a splitter cable, medical cable, or the like, or in a sensor assembly.

The decoupling circuit **540c** is shown decoupling a power line **566c** connected to a monitor from a power line **576c** connected to a sensor. The decoupling circuit **540c** can be used together with the decoupling circuit **540b** of FIG. **5B** in some embodiments. For example, the decoupling circuits **540b**, **540c** may be provided on the same circuit board. Like the decoupling circuit **540b**, the decoupling circuit **540c** uses feedback to dynamically correct or control the output of the decoupling circuit **540c**.

The decoupling circuit **540c** in the depicted embodiment is a flyback transformer having two primary windings **550c**, **551c** and one secondary winding **552c**. The primary winding **550c** receives power (VIN) from the power line **566c**. A switched mode power supply **560** also receives power (VIN) from the power line **566c**. In an embodiment, the switched mode power supply **560** is a DC-DC converter or the like. A switch pin **562** of the power supply **560** can be enabled or otherwise actuated to allow power (VIN) to cycle through the primary winding **550c**. The switch pin **562** may cause the power to be switched according to a predetermined duty cycle. Feedback may be used, as described below, to maintain a stable or relatively stable duty cycle.

As the primary winding **550c** is being energized, the primary winding **550c** may store energy in itself and in a core **563** of the transformer. Through inductive coupling, this energy may be released into the secondary winding **552c** and into the primary winding **551c**. The polarity of the windings **552c**, **551c** (as indicated by the dots on the windings) may be the same to facilitate the transfer of energy. Likewise, the polarity of the windings **552c**, **551c** may differ from the polarity of the winding **550c**.

Like the feedback receiving photodiode **545a** described above, the primary winding **551c** acts as a flyback winding in certain embodiments to transmit the received power as a feedback signal. A rectifier **565** rectifies the power received from the primary winding **551c** and provides a feedback power VFB to a feedback pin **566** of the power supply **560**. The power supply **560** may then use the difference between the received feedback power VFB and the transmitted power VIN to adjust VIN to compensate for any error in the transmitted power. For example, the power supply **560** can adjust the duty cycle described above based at least partly on the error, e.g., by increasing the duty cycle if the VFB is low and vice versa. This flyback operation can advantageously maintain a stable or substantially stable power duty cycle despite varying load conditions on the decoupling circuit **540c**.

The secondary winding **550c** can provide an output to a linear power supply **570**, which may rectify the received power, among other functions. The linear power supply **570** may provide the power to the power line **576c** for transmission to the sensor.

FIGS. **6A** and **6B** illustrate an example splitter cable **620**. FIG. **6A** depicts a side view of the splitter cable **620** while FIG. **6B** depicts a bottom view of the splitter cable **620**. The splitter cable **620** includes a housing **607** that includes a circuit board **640** having a decoupling circuit, shown in phantom. The housing **607** further includes wires **642**, also shown

in phantom, in communication with the circuit board **640** and with first cable sections **630a**, **630b** and a second cable section **622** of the splitter cable **620**. The housing **607** is also shown connected to the second cable section **622**, which in turn connects to a connector **621**. In an embodiment, the connector **621** is used to connect the splitter cable **620** to a physiological monitor.

The housing **607** of the splitter cable **620** further connects to one of the first cable sections **630a** through a connector **631**. Another one of the first cable sections **630b** is integrally coupled to the housing **607** of the splitter cable **620** in the depicted embodiment. In one implementation, the splitter cable **620** and the cable **630b** are used to obtain physiological information from a single sensor, and the cable **630a** may be added to the splitter cable **620** to obtain physiological information from an additional sensor. It should be noted that in an alternative embodiment, the first cable section **630b** is not integrally attached to the housing **607** but instead attaches to the housing a second connector. Or, both of the first cable sections **630** could be integral to the housing **607**.

The circuit board **640** interfaces with both first cable sections **630a**, **630b** and with the second cable section **622**. The circuit board **640** may include, for example, one or more integrated circuits or discrete circuit components that together are implemented as a decoupling circuit. In addition, the circuit board **640** can include one or more information elements for storing various forms of data.

Turning to FIG. **7**, additional embodiments of cable assemblies **730** will be described. As explained above with respect to FIG. **1**, cable assemblies having two separate cables may be provided in some embodiments. These separate cables can include a sensor cable **712** and an instrument cable **714**. In one embodiment, the sensor cable **712** is a short, lightweight cable, adapted to facilitate comfortable attachment of sensors to a medical patient. In certain embodiments, the instrument cable **714** is a heavier, sturdier cable, acting as a durable interface between the sensor cable **712** and a monitor. Sensor cables **712** and instrument cables **714** may be periodically replaced. Periodic replacement is advantageous in certain embodiments for a wide variety of reasons. For example, the cable can become soiled or damaged, causing cable failure inaccurate results, or patient cross-contamination.

In addition, one or more decoupling circuits or information elements (see FIGS. **7** and **8**) may be incorporated into the cable assembly **730** in certain embodiments. The information elements may store cable management information related to usage of the cable assembly and devices connected to the cable assembly. The information elements may also store patient context information related to patient identification and patient movement (flow) among hospital departments, thereby tracking the patient's progress throughout the hospital. Examples of patient context information are described more fully in U.S. patent application Ser. No. 11/633,656, titled "Physiological Alarm Notification System," filed Dec. 4, 2006, which is hereby incorporated by reference in its entirety. Moreover, the information elements can store physiological information in some implementations.

Referring again to FIG. **7**, a sensor cable **712** is shown connected to a sensor assembly **750**. The sensor cable **712** may include a flexible cable section **732** having an elongated shape, a connector **751** for interfacing with a sensor assembly **750**, and a connector **737** for interfacing with an instrument cable **714**. The flexible nature of the cable section **732** in one embodiment is provided to enable greater patient comfort, as the patient can move more easily with a flexible sensor cable **712** attached.

The depicted example instrument cable **714** includes a stiff or relatively rigid, durable cable section **734** having an elongated shape, a connector **735** for interfacing with the sensor cable **712**, and a connector **731** for interfacing with a physiological monitor. As the instrument cable **714** of various embodiments is not connected directly to the patient, the instrument cable section **734** may be less flexible (and more durable) than the sensor cable section **732**, thereby extending the life of the instrument cable **714**.

Decoupling circuitry and/or information elements may be included within the sensor cable **712**, the instrument cable **714**, or both. The decoupling circuits and/or information elements may be placed in any of the connectors **737**, **751**, **735**, or **731** or in either cable section **732**, **734**. In other embodiments, one or more information elements may be included in any of the splitter cables described above. In alternative embodiments, the sensor cable **712** can be a splitter cable.

FIGS. **8A** and **8B** illustrate example layouts of a physiological monitoring system **800**. FIGS. **8A** and **8B** illustrate various information elements **860**, **862**, and **864**. The information elements **860**, **862**, and **864** may be used to store cable management information, patient context information, and/or physiological information. Although not shown, the information elements **860**, **862**, and **864** may also be used in the splitter cable embodiments described above. Moreover, decoupling circuitry may be included in the cables of FIGS. **8A** and **8B**.

Referring to FIG. **8A**, a physiological monitoring system **800A** includes a physiological monitor **810** that communicates with a sensor **850** through an instrument cable **814** and a sensor cable **812**. An information element **860** is included in the sensor cable **812**.

The physiological monitor **810** interfaces with the instrument cable **814** using a connector **819**, which mates with a connector **831** of the instrument cable **814**. The instrument cable **814** mates in turn with the sensor cable **812** through a connector **835** on the instrument cable **814** and a corresponding connector **837** on the sensor cable **812**. The sensor cable **812** in turn connects to a sensor **850** through a connector **833** and a corresponding connector **851** on the sensor **850**. In alternative embodiments, the sensor cable **812** may be a splitter cable.

In the embodiment shown, the information element **860** is located in the connector **837**. Other placements for the information element **860** are also possible. For example, the information element **860** could be located anywhere in the sensor **850** or in the sensor cable **812**, including in a sensor cable section **832** or the connector **833**. In addition, the information element **860** could also be located in the instrument cable **814** instead, or two or more information elements **860** could be used, one or more in each cable **812**, **814** (see, e.g., FIG. **8**).

The information element **860** can include any one or more of a wide variety of information elements. In an embodiment, the information element **860** is a non-volatile information element, such as, for example, an erasable programmable read-only memory ("EPROM"). "EPROM" as used herein includes its broad ordinary meaning known to one of skill in the art, including those devices commonly referred to as "EEPROM" "EPROM," as well as any types of electronic devices capable of retaining their contents even when no power is applied and/or those types of devices that are reprogrammable. In an embodiment, the information element is an impedance value associated with the sensor, such as, for example, a resistive value, an impedance value, an inductive value, and/or a capacitive value or a combination of the foregoing. In addition, the cable's information element could be provided through an active circuit such as a transistor net-

work, memory chip, flash device, or other identification device, including multi-contact single wire information elements or other devices, such as those commercially available from Dallas Semiconductor or the like. Moreover, the information element may be random access memory (RAM), read-only memory (ROM), or a combination of the same.

In an embodiment, the physiological monitor **810** communicates with the information element **860** via a serial transmission line **840**. In one embodiment, the serial transmission line **840** is a multi-drop bus, although in alternative embodiments, the serial transmission line **840** is a 1-wire bus, a SCSI bus, or another form of bus. Once the physiological monitor **810** determines that it is connected to the sensor cable **812**, it sends and receives signals to and from the information element **860** to access cable management information and/or patient context information. Alternatively, the physiological monitor **810** does not access the information element **860** until requested to do so by a user (e.g., a clinician). In addition, the physiological monitor **810** may also automatically access the information element **860** or access the information element **860** in response to a user request.

Cable management information that may be stored on the information element **860** may include information on cable usage, sensor usage, and/or monitor usage. Cable usage data may include, for example, information on the time the cable has been in use, enabling the physiological monitor **810** to determine when the sensor cable **812** is near the end of its life. Sensor usage data may include, for example, information on what sensors have been attached to the sensor cable **812**, for how long, and the like. Similarly, monitor usage data may include, for example, information on what monitors have been attached to the sensor cable **812**, for how long, and the like. More detailed examples of cable management information are described below, with respect to FIG. **9**.

Patient context information that may be stored on the information element **860** may include patient identification data and patient flow data. In one example embodiment, patient identification data includes at least the patient's name and one or more identification numbers. Patient flow data may include, for example, details regarding the departments the patient has stayed in, the length of time therein, and devices connected to the patient. More detailed examples of patient context information may also be found below, with respect to FIG. **9**.

Advantageously, in certain embodiments, the physiological monitor **810** uses the cable management information in various embodiments to determine when to replace a cable in order to prevent cable failure. The physiological monitor **810** may also use the information element **860** to track sensor **850** and physiological monitor **810** use. Some implementations of the physiological monitor **810** enable the physiological monitor **810** to transmit some or all of the cable management information to a central nurses station or to a clinician's end user device, such as is described in further detail below, with respect to FIG. **9**. In some implementations, the physiological monitor **810** or a central nurses station sends an alarm to the end user device that alerts the user to impending cable failure. For example, a clinician might receive an alarm notification on a personal digital assistant (PDA), pager, or the like, which enables the clinician to replace the cable before it fails. Patient context information, including identification information, may also be provided along with the alarm to help the clinician identify the cable with the patient.

Moreover, the physiological monitor **810** may transmit some or all of the cable management information and/or patient context information to a central server (see, e.g., FIG. **10**). Inventory software on the central server can use this

information to preemptively order new cables when cable inventory is low or at other times.

Different sensors **850** and physiological monitors **810** may be attached to the same sensor cable **812**. Thus, the cable management information may also include a list of which sensors **850** and physiological monitors **810** have been attached to the cable **812**, how long they were attached, and the like. The physiological monitor **810** may also provide this information to the central server to keep track of or journal this information. The cable management information is therefore used in some embodiments to derive patient monitoring metrics, which may be analyzed to monitor or improve hospital operations. A hospital may use these metrics, for example, to determine when to replace cables or to determine whether personnel are using the cables improperly or are damaging the cables through improper use.

The patient context information in some embodiments also enables the sensor cable **812** to be identified with a particular patient. As the sensor cable **812** of some embodiments may be transported with the patient when the patient is moved about the hospital, when the sensor cable **812** is attached to different monitors **850**, the data stored in the information element **860** may be transferred to the new monitor **850**. Thus, during the patient's stay at the hospital or at discharge, the information element **860** of certain embodiments has patient flow data that a hospital can use to monitor or improve operations. The flow data of multiple patients may be used, for instance, to determine the number of patients staying in a particular department at a given time and the equipment used during those patients stay. Knowing this information, the hospital can adjust equipment inventories and staff assignments to more efficiently allocate hospital resources among the various departments.

FIG. **8B** illustrates another embodiment of a monitoring system **800B**. The monitoring system **800B** preferably includes all the features of the monitoring system **800A** and additionally includes an information element **862** in the instrument cable **814** and an information element **864** in the sensor **850**. The information elements **862**, **864** may have the same or different characteristics of the information element **860**, including the same or different memory type, capacity, latency, or throughput.

In an embodiment, the serial transmission line **840** connects the physiological monitor **810** to the information element **860** in the sensor cable **812** as above. However, the serial transmission line **840** also connects to the information elements **862**, **864**. The physiological monitor **810** may therefore access the information elements **860**, **862**, **864** while running generally few transmission lines **840**.

The information elements **862**, **864** may have all or a portion of the functionality of the information element **860**. In one embodiment, the same data is stored in each of the information elements **860**, **862**, **864**, thereby providing data redundancy. Additionally, in such embodiments the instrument cable **814** may stay with the patient as the patient moves from one department to another, in place of or in addition to the sensor cable **812**. Moreover, in one embodiment only the instrument cable **814** or the sensor assembly **850** has an information element **862** or **864**, and the sensor cable **812** does not have an information element **860**.

The placement of the information elements **862**, **864** can be in any of a variety of locations. For example, the information element **862** may be located in either one or the connectors **831**, **835** or in the instrument cable section **834**. Likewise, the information element **864** of the sensor **850** may be located in the connector **851** or in another part of the sensor **850**.

Although not shown, the sensor cable **812** and/or the instrument cable **814** may have multiple information elements in some embodiments. When multiple information elements are used, certain data may be stored on some information elements, and other data may be stored on others. For instance, cable management information may be stored on a separate information element from patient context information, and physiological information may be stored on yet another information element.

FIG. **8C** illustrates an embodiment of a circuit **800C** for facilitating communication between a monitor and one or more information elements **890**. The circuit **800C** may be included in any of the cable or sensor assemblies described above, including in a splitter cable, a non-splitter cable, an instrument cable, a sensor cable, a sensor assembly, combinations of the same, and the like. In addition, the circuit **800C** may be used in conjunction with the circuits **500B** and **500C** in a single cable, e.g., on the same circuit board, or in combination with multiple cables and/or sensor assemblies.

Advantageously, in certain embodiments, the circuit **800C** provides electrical decoupling for communications lines **877**, **879**, **882**, and **883**, which provide communications between a monitor and one or more information elements. In addition, the circuit **800C** may provide sensor connection status to a monitor via a sensor detect circuit **872**.

A decoupling circuit **540d** shown includes digital decoupling logic to electrically decouple one or more information elements and one or more sensors from the monitor. The decoupling circuit **540d** includes transformers on a chip and associated logic that perform digital decoupling. In one embodiment, the decoupling circuit **540d** is a ADuM130x series chip from Analog Devices. In other embodiments, optocouplers and/or other transformers are used.

Communications lines **882**, **883** allow the monitor to transmit and receive data to and from one or more information elements **890**. The line **882** is a monitor transmit line **882**, and the line **883** is a monitor receive line **883**. Each of these lines **882**, **883** is electrically decoupled from the communications line **877** by the decoupling circuit **540d**. The communication lines **877**, **879** may be electrically coupled with the one or more information elements **890**.

In an embodiment, the communications line **877** is a bus, such as a 1-wire bus. The communications line **877** may be used to both transmit and receive data to and from the monitor. The communications line **879** may be used to receive data from the monitor. A MOSFET switch **876** or the like is in communication with the depicted communications line **879**, which selectively transmits signals to the one or more information elements **890**.

The monitor receive line **883** is in communication with a power validation circuit **878**, which determines whether the feedback power VFB described above with respect to FIG. **5C** is high enough. If the feedback power VFB is too low, the data received from the information elements **890** may not be used because the data may be corrupt.

In the depicted embodiment, the power validation circuit **878** includes a comparator **889** that compares the feedback power VFB with a reference voltage. If the feedback power VFB is equal to or higher than the reference voltage, the comparator **889** might output a high voltage. This high voltage can be selectively overridden by a MOSFET switch **887** in response to communications received from the information elements **890**. If the feedback power VFB is lower than the reference voltage, the comparator **889** might output a low voltage. The low voltage can override the MOSFET switch **887** such that communications from the information elements **890** are not sent to the monitor.

In the depicted embodiment, sensor connection status is provided to the monitor via the sensor detect circuit 872. The sensor detect circuit 872 includes a sensor detect line 875 in communication with a pull-up resistor 873. When a sensor 885 is not connected to the line 875, the line 875 may be pulled high. This high voltage may be inverted by a MOSFET switch 874 to provide a low signal to the monitor via sensor connect line 881. The switch 874 may be omitted in some embodiments.

In response to a sensor 885 being connected to the sensor detect line 875, a shorted line 886 (or low resistance line) in the sensor 885 can cause the line 875 to be pulled low. This low value can be inverted by the switch 874 to provide a high signal to the monitor. This signal can indicate that the sensor 885 is connected. Conversely, if the sensor 885 is disconnected, the line 875 may again be pulled high, resulting in a low output of the switch 874. As a result, the monitor may receive a rapid or near-immediate indication that the sensor 885 has been disconnected.

The sensor detect circuit 872 also includes passive elements in the depicted embodiment, such as a capacitor 891, to smooth or debounce contact oscillations from the sensor 885. Thus, the sensor detect circuit 872 can also be considered a debounce circuit. In other embodiments, the sensor detect circuit 872 can be replaced with other forms of debounce circuitry.

Advantageously, in certain embodiments, the sensor detect circuit 872 can be used instead of polling the one or more information elements 890 frequently to determine if the sensor 885 is connected. Alternatively, the polling cycle of the one or more information elements 890 may be reduced. Reducing or eliminating the polling cycle can reduce power consumption by the circuit 800C.

The sensor detect circuit 872 may be used to detect the connection of cables, such as a splitter cable, as well as or instead of detecting sensor connections. In some embodiments, a sensor detect line 875 may be provided for each sensor in a multi-sensor system, each cable, or the like. Moreover, the sensor detect circuit 872 may also be used with cables that do not have a decoupling circuit.

FIG. 9 illustrates a block diagram of example forms of data that can be stored on an information element. In the depicted embodiment, patient context information 920, cable management information 930, and physiological information 940 are shown. The patient context information can include patient identification data 922 and patient flow data 924. Cable management information 930 can include cable usage data 932, sensor usage data 934, and instrument usage data 936. However, while the data is depicted in FIG. 9 as comprising discrete categories, data from one category may be included within another. Data from one or more categories also may not be included, or alternatively, additional data categories than that shown may be included.

Turning to more specific examples, in one embodiment patient identification data 922 can include a patient's name, a patient's unique hospital identification number, type of patient or body tissue, information about the patient's age, sex, medications, and medical history, and other information that can be useful for the accuracy of alarm settings and sensitivities and the like. In addition, the patient identification data 922 may also include an SpO₂ fingerprint, determined by a pulse oximeter. In one such embodiment, the SpO₂ fingerprint is determined by calculating a ratio of an infrared detected wavelength and a red detected wavelength. The SpO₂ fingerprint can be used to detect if a sensor or cable is being improperly reused.

Patient flow data 924 can include a record of departments the patient has visited, length of stay (LOS) in those departments, overall LOS in the hospital, admittance date and time, discharge date and time, time stamps for events occurring in the hospital, and the like. Some or all of this information, in conjunction with the patient identification data, can constitute a patient flow profile.

Cable usage data may include buyer or manufacturer information cable type, serial number of the cable, date of purchase, time in use, and cable life monitoring functions (CLM), including near expiration percentage, update period, expiration limit, and an index of functions. In addition, the cable usage data 932 may include numerous read write parameters, such as the number of times the cable is connected to a monitoring system, the number of times the cable has been successfully calibrated, the total elapsed time connected to a monitor system, the number of times the cable has been connected to one or more sensors, the total time used to process patient vital parameters, the cumulative current, voltage, or power applied to the cable, the cumulative temperature of the cable, and the expiration status of the cable.

In an embodiment, the number of times the cable is placed on or removed from a patient is monitored and an indication is stored in the memory. The number of times a sensor connected to the cable is placed on or removed from a patient can be monitored by monitoring the number of probe off conditions sensed, or it can be monitored by placing a separate monitoring device on the cable or sensor to determine when a sensor clip is depressed, opened, removed, replaced, attached, or the like.

In an embodiment, the average operating temperature of the cable is monitored and an indication stored. This can be done, for example, through the use of bulk mass or through directly monitoring the temperature of the cable or the temperature of the cable's connectors. In an embodiment, the number of different monitors connected to the cable is tracked and an indication is stored in memory. In an embodiment, the number of times the cable is calibrated is monitored, and an indication is stored in memory. In an embodiment, the number of patients that use a cable is monitored and an indication is stored. This can be done by, for example, by storing sensed or manually entered information about the patient and comparing the information to new information obtained when the cable is powered up, disconnected and/or reconnected, or at other significant events or periodically to determine if the cable is connected to the same patient or a new patient. In an embodiment, a user is requested to enter information about the patient that is then stored in memory and used to determine the useful cable life. In an embodiment, a user is requested to enter information about cleaning and sterilization of the cable, and an indication is stored in the memory. Although described with respect to measuring certain parameters in certain ways, various other electrical or mechanical measurements can be used to determine any useful parameter in measuring the useful life of a cable.

Sensor usage data 934 can include some or all of the same information as the cable usage data but applied to sensors attached to the cable, and may also include information on the type or operation of the sensor, type or identification of a sensor buyer, sensor manufacturer information, sensor characteristics including the number of wavelengths capable of being emitted, emitter specifications, emitter drive requirements, demodulation data, calculation mode data, calibration data, software such as scripts, executable code, or the like, sensor electronic elements, sensor life data indicating whether some or all sensor components have expired and should be replaced, encryption information, monitor or algo-

rithm upgrade instructions or data, or the like. In an embodiment, the sensor usage data **934** can also include emitter wavelength correction data.

Sensor usage data **934** can also include the number of emitting devices, the number of emission wavelengths, data relating to emission centroids data relating to a change in emission characteristics based on varying temperature, history of the sensor temperature, current, or voltage, emitter specifications, emitter drive requirements, demodulation data, calculation mode data, the parameters it is intended to measure (e.g., HbCO, HbMet, etc.) calibration data, software such as scripts, executable code, or the like, sensor electronic elements, whether it is a disposable, reusable, or multi-site partially reusable, partially disposable sensor, whether it is an adhesive or non-adhesive sensor, whether it is reflectance or transmittance sensor, whether it is a finger, hand, foot, forehead, or ear sensor, whether it is a stereo sensor or a two-headed sensor, sensor life data indicating whether some or all sensor components have expired and should be replaced, encryption information, keys, indexes to keys or has functions, or the like monitor or algorithm upgrade instructions or data, and some or all of parameter equations.

Instrument usage data **936** can include buyer or manufacturer information, information on the type of monitors that the cable has connected to, number of monitors the cable has connected to, duration of cable connections to the monitors, duration of use of the monitor, trend history, alarm history, sensor life, an identification number for a specific monitor, and the like. In addition, the instrument usage data **936** may include all or a portion of all the cable and sensor usage data described above.

The physiological information **940** may include any of the physiological parameters described above, obtained from the sensors or monitors attached to the information element **960**. In one implementation, the information element **960** enables the physiological information **940** to be transferred between physiological monitors. As a result, a historical view of the patient's physiological parameters may be provided to different monitors throughout the hospital. Thus, clinicians in different departments can observe the patient's physiological information obtained in a previous department, enabling clinicians to provide a higher quality of care.

FIG. 10 illustrates an embodiment of a physiological monitoring system **1000** which may be used in a hospital, nursing home, or other location where medical services are administered (collectively "hospital"). Certain aspects of the physiological monitoring system **1000** are described in more detail in U.S. patent application Ser. No. 11/633,656, titled "Physiological Alarm Notification System," filed Dec. 4, 2006, which is hereby incorporated by reference in its entirety.

The physiological monitoring system **1000** of certain embodiments includes patient monitoring devices **1002**. The patient monitoring devices **1002** of various embodiments include sensors **1050**, one or more physiological monitors **1010**, cables **1030** attaching the sensors **1050** to the monitors **1010**, and a network interface module **1006** connected to one or more physiological monitors **1010**. Each patient monitoring device **1002** in some embodiments is part of a network **1020** of patient monitoring devices **1002**. As such, the patient monitoring devices **1002** in these embodiments can communicate physiological information and alarms over a hospital wireless network (WLAN) **1026** or the Internet **1050** to clinicians carrying end user devices **1028**, **1052**.

The network interface module **1002** of certain embodiments transmits physiological information on demand or in the event of an alarm to the end-user devices **1028**, **1052** and/or transmits the alarm to a central nurses station. Alter-

natively, the network interface module **1002** transmits information and alarms to a server **1036**. The server **1036** is a computing device, such as an appliance server housed in a data closet or a workstation located at a central nurses station. The server **1036** passes the information or alarms to the end user devices **1028**, **1052** or to the central nurse's station. The alarms may be triggered when certain physiological parameters exceed safe thresholds, thereby enabling clinicians to respond rapidly to possible life-threatening situations. Situations giving rise to an alarm might include, for example, decreased heart rate, respiratory rate, low SpO₂ levels, or any other physiological parameter in an abnormal range.

The network interface module **1002** in one embodiment also performs cable management by generating an alarm when one of the cables **1030** is nearing the end of its life. The network interface module **1002** determines whether the cable's **1030** life is close to expiring by, for example, analyzing some or all of the data described above with respect to FIG. 9. In one embodiment, if the network interface module **1002** determines that the cable life is close to expiration, the network interface module **1002** provides an expiration message as an alarm.

In one embodiment, the server **1036** receives this expiration message. The server **1036** then checks an inventory stored in a database **1038** to see if a replacement cable is available. If there is no replacement cable in the inventory, the server may forward the message to a supplier **1070** over the Internet **1050** (or through a WAN, leased line or the like). In an embodiment, the server **1036** transmits an email message to a supplier **1070** that indicates the cable location, cable condition, and/or other cable usage data. The supplier **1070** in one embodiment is a cable seller. Upon receiving the message, the supplier **1070** may automatically ship a new cable to the hospital. Consequently, cable **1030** inventories are able to be maintained with minimal or no user intervention in this implementation, and cables **1030** may be replaced preemptively, before cable failure.

In additional embodiments, the network interface module **1006** may monitor sensor utilization, such as the number of sensors used during the patient's stay, the types of sensors, and the length of time in use before replacement. Such data can be used by the hospital to preemptively plan restocking and set department par inventory levels. In addition, a supplier can use this data to restock the hospital or implement a just in time inventory control program. Moreover, such information can be used by the supplier to improve overall cable reliability and for the hospital to better plan and manage consumables.

The network interface module **1006** of various implementations also performs context management. In one embodiment, context management includes associating context information with physiological information to form a contextual data package. As described above, context information may include patient identification data and patient flow data. In addition, context information may include context information related to usage of the network interface module **1006** and context information related to the network. For example, this additional context information may include an identification number of the network interface module **1006**, time stamps for events occurring in the physiological monitoring system **1000**, environmental conditions such as changes to the state of the network and usage statistics of the network interface module **1006**, and identification information corresponding to the network (e.g., whether the network connection is WiFi or Ethernet).

The network interface module **1006** receives context information in one embodiment by a nurse entering the informa-

tion in the network interface module **1006** or from the server **1036**. The network interface module **1006** transmits or communicates the contextual data package to clinicians during an alarm, upon clinician request, or on a scheduled basis. In addition, the network interface module **1006** may transmit a continuous stream of context information to clinicians.

The server **1036** receives contextual data packages from a plurality of network interface modules **1006** and stores the contextual data package in a storage device **1038**. In certain embodiments, this storage device **1038** therefore archives long-term patient data. This patient data may be maintained even after the patient is discharged. Thus, context information may be stored for later analysis to, for example, develop patient care metrics and improve hospital operations. The patient data could be deleted after the care metrics are developed to protect patient privacy.

Although the functions of cable management and context management have been described as being performed by the network interface module **1006**, in certain embodiments, some or all of these functions are instead performed by the physiological monitor **1010**. In addition, the physiological monitor **1010** and the network interface module **1006** may both perform cable management and/or context management functions.

FIG. **11** illustrates an embodiment of a usage tracking method **1100** for tracking the life of a medical cable. In one implementation, the usage tracking method **1100** is performed by the network interface module and/or one of the physiological monitors described above. More generally, the usage tracking method **1100** may be implemented by a machine having one or more processors. Advantageously, in certain embodiments, the usage tracking method **1100** facilitates replacing a cable prior to failure of that cable.

The usage tracking method **1100** begins by obtaining sensor parameters from a sensor at block **1102**. At block **1104**, cable usage information stored in an information element is tracked. The cable usage information can be tracked by at the same time or substantially the same time as obtaining sensor parameters from the sensor. Alternatively, the cable usage information may be tracked by determining cable usage at the start or end of monitoring (e.g., obtaining sensor parameters), or periodically throughout monitoring. In addition, the cable usage information may be tracked even if the block **1102** were not performed, e.g., when the monitor is not currently obtaining parameters from the sensor.

At decision block **1106**, it is determined whether the cable's life is close to expiring (or whether the cable has in fact expired). This determination may be made using the data described above with respect to FIG. **9**. In addition, the this determination may be made using sensor life functions applied analogously to the life of the cable.

If it is determined that the cable life is close to expiration (or has expired), an expiration message is provided at block **1108**. In one embodiment, this message is provided as an alarm on the monitor or at a central nurses station. The message may also be provided to a clinician's end user device, which may be located in the hospital or at a remote location. Moreover, the message may be provided to a server, which forwards the message to a supplier, which ships a new cable. In an embodiment, the message is an email that indicates the cable location, cable condition, and/or other cable usage data. If, however, it is determined that the cable life is not close to expiration (or is not expired), the usage tracking method **1100** loops back to block **1102** to continue monitoring. In effect, the usage tracking method **1100** may continue monitoring and/or tracking cable usage information until the cable is close to expiration or has expired.

FIG. **12** illustrates an embodiment of a cable inventory method **1200** for controlling cable inventory. The cable inventory method **1200** may be performed by a server, such as the server **1038** described above. More generally, the cable inventory method **1200** may be implemented by a machine having one or more processors. In one embodiment, the method **1200** is performed in response to the method **1100** providing an expiration message at step **1108**.

At block **1202**, an expiration message is received from a monitor, indicating that a cable is close to expiration or has expired. At block **1204**, an inventory is checked for a replacement cable. This inventory may be a hospital inventory, a record of which may be maintained in a hospital database or the like.

If it is determined at decision block **1206** that there is no replacement cable in the inventory, a new cable is ordered automatically to order a at block **1208**. In an embodiment, this block **1208** is performed by electronically contacting a supplier to order the cable, for example, by sending a request over a network such as the Internet. Consequently, in certain embodiments, the cable inventory method **1200** enables the cable to be replaced preemptively, before cable failure. If, however, there is a replacement cable in inventory, the cable inventory method **1200** ends. However, in alternative embodiments, the cable inventory method **1200** orders a replacement cable regardless of the inventory, such that a predetermined level of cable inventory is maintained.

In additional embodiments, the cable inventory method **1200** may monitor sensor utilization, such as the number of sensors used during the patient's stay, the types of sensors, and the length of time in use before replacement. Such data can be used by the hospital to preemptively plan restocking and set department par inventory levels. In addition, a supplier can use this data to restock the hospital or implement a just-in-time program. Moreover, such information can be used by the supplier to improve overall cable reliability, and for the hospital to better plan and manage consumables.

FIG. **13** illustrates an example context management method **1300** for managing patient context. In an embodiment, the context management method **1300** is performed by a physiological monitor, such as any of the monitors described above. More generally, certain blocks of the context management method **1300** may be implemented by a machine having one or more processors. The context management method **1300**, in certain embodiments, advantageously enables a patient to be assigned a cable with a unique identifier upon the first connection of the cable to the patient or to a monitor.

At block **1300**, a cable is connected to a monitor, for example, by a clinician such as a nurse. Thereafter, a temporary patient ID is assigned to the cable at block **1304**. The temporary ID may be automatically assigned when power is provided to the information element in the cable, or a prompt may be provided to a clinician, who then assigns the ID. In addition, the temporary ID may also be previously stored on the cable. The temporary patient ID enables the cable to be identified as uniquely relating to the patient, prior to the patient's identification information being provided to the cable. The temporary patient ID may be stored in the information element of the cable.

At block **1306**, patient flow data is stored in the information element. The patient flow data may include flow data described above with respect to FIG. **9**. For example, the patient flow data may include information regarding connected devices, a department ID associated with the cable, and time spent by the cable in a department. By storing patient flow data, the context management method **1300** can enable

the flow of the patient may be monitored upon connection of the cable to a monitor. Thus, even if the nurse neglects to identify the cable with the patient, the cable can have data indicating when it is being used on the same or a different patient.

At decision block **1308** it is determined whether a real patient ID has been provided. If so, then the temporary ID is replaced with the real patient ID at block **1310**. The real patient ID may include any of the patient identification information described above, with respect to FIG. **13**. If, however, it is determined that a real patient ID has not been provided, the context management method **1300** loops back to block **1306** to continue storing patient flow data in the information element.

FIG. **14** illustrates another example context management method **1400** for managing patient context. In an embodiment, the context management method **1400** is performed by one or more monitors, such as any of the monitors described above. More generally, certain blocks of the context management method **1400** may be implemented by a machine having one or more processors.

At block **1402**, a cable is connected to a monitor. In one embodiment, this block is performed by a clinician, such as a nurse. Patient flow data is then stored in an information element at block **1404**. The patient flow data may include the flow data described above with respect to FIG. **9**.

At decision block **1406**, it is determined whether the cable has been connected to a new monitor. If it has, patient flow data is transferred from the cable to the new monitor at block **1408**. In an embodiment, the new monitor determines whether the cable has been connected to the new monitor. Alternatively, the cable makes this determination. Transferring the patient flow data to the new monitor provides, in certain embodiments, the advantage of enabling the monitor to know where the patient has been in the hospital and for how long. If a new monitor has not been connected, the context management method **1400** ends.

Those of skill in the art will understand that information and signals can be represented using any of a variety of different technologies and techniques. For example, data, instructions, commands, information, signals, bits, symbols, and chips that can be referenced throughout the above description can be represented by voltages, currents, electromagnetic waves, magnetic fields or particles, optical fields or particles, or any combination thereof.

Those of skill will further appreciate that the various illustrative logical blocks, modules, circuits, and algorithm steps described in connection with the embodiments disclosed herein may be implemented as electronic hardware computer software, or combinations of both. To clearly illustrate this interchangeability of hardware and software, various illustrative components, blocks, modules, circuits, and steps have been described above generally in terms of their functionality. Whether such functionality is implemented as hardware or software depends upon the particular application and design constraints imposed on the overall system. Skilled artisans can implement the described functionality in varying ways for each particular application, but such implementation decisions should not be interpreted as causing a departure from the scope of this disclosure.

The various illustrative logical blocks, modules, and circuits described in connection with the embodiments disclosed herein can be implemented or performed with a machine, such as a general purpose processor, a digital signal processor (DSP), an application specific integrated circuit (ASIC), a field programmable gate array (FPGA) or other programmable logic device, discrete gate or transistor logic,

discrete hardware components, or any combination thereof designed to perform the functions described herein. A general purpose processor can be a microprocessor, processor, controller, microcontroller, state machine, etc. A processor can also be implemented as a combination of computing devices, e.g., a combination of a DSP and a microprocessor, a plurality of microprocessors, one or more microprocessors in conjunction with a DSP core, or any other such configuration. In addition, the term "processing" is a broad term meant to encompass several meanings including, for example, implementing program code, executing instructions, manipulating signals, filtering, performing arithmetic operations, and the like.

The steps of a method or algorithm described in connection with the embodiments disclosed herein can be embodied directly in hardware, in a software module executed by a processor, or in a combination of the two. A software module can reside in RAM memory, flash memory, ROM memory, EPROM memory, EEPROM memory, registers, hard disk, a removable disk, a CD-ROM, a DVD, or any other form of storage medium known in the art. A computer-readable storage medium is coupled to the processor such that the processor can read information from, and write information to, the storage medium. In the alternative, the storage medium may be integral to the processor. The processor and the storage medium can reside in an ASIC. The ASIC can reside in a user terminal. In the alternative, the processor and the storage medium can reside as discrete components in a user terminal.

The modules can include, but are not limited to, any of the following: software or hardware components such as software object-oriented software components, class components and task components, processes, methods, functions, attributes, procedures, subroutines, segments of program code, drivers, firmware, microcode, circuitry, data, databases, data structures, tables, arrays, and/or variables.

In addition, although certain inventions have been disclosed in the context of certain embodiments, it will be understood by those skilled in the art that the inventions disclosed herein extend beyond the specifically disclosed embodiments to other alternative embodiments and/or uses of the inventions and obvious modifications and equivalents thereof. In particular, while the system and methods have been described in the context of certain embodiments, the skilled artisan will appreciate, in view of the present disclosure, that certain advantages, features and aspects of the acoustic signal processing system, device, and method may be realized in a variety of other applications and software systems. Additionally, it is contemplated that various aspects and features of the inventions disclosed herein can be practiced separately, combined together, or substituted for one another, and that a variety of combination and subcombinations of the features and aspects can be made and still fall within the scope of the inventions disclosed herein. Furthermore, the systems described above need not include all of the modules and functions described in certain embodiments. Thus, it is intended that the scope of the inventions disclosed herein disclosed should not be limited by the particular disclosed embodiments described above, but should be determined only by the claims that follow.

What is claimed is:

1. A pulse oximetry system for reducing the risk of electric shock to a medical patient, the pulse oximetry system comprising:

a plurality of physiological sensors, at least one of the physiological sensors comprising:

- a light emitter configured to impinge light on body tissue of a living patient, the body tissue including pulsating blood, and
- a detector responsive to the light after attenuation by the body tissue, wherein the detector is configured to generate a signal indicative of a physiological characteristic of the living patient; and

a physiological monitor, the physiological monitor configured to receive the signal from the at least one physiological sensor and determine the physiological characteristic of the living patient; and

a splitter cable comprising:

- a monitor connector operative to connect to a physiological monitor,
- a plurality of sensor connectors each operative to connect to one of the physiological sensors,
- a plurality of cable sections each disposed between a sensor connector and the monitor connector, each of the cable sections comprising one or more electrical conductors, the one or more electrical conductors for at least some of the cable sections comprising:
 - a power line configured to supply power to one or more of the plurality of physiological sensors;
 - a signal line configured to transmit the physiological signals from one or more of the physiological sensors to the physiological monitor; and
 - a ground line configured to provide an electrical return path for the power line;
- one or more decoupling circuits in communication with at least one power line, signal line, and ground line, the one or more decoupling circuits configured to communicate physiological signals between one or more of the physiological sensors and the physiological monitor, the one or more decoupling circuits operative to electrically decouple the physiological sensors from each other, wherein the one or more decoupling circuits are configured to substantially prevent ground loops from forming in the ground line;
- an information element configured to store cable management information, patient context information, or physiological information; and
- a digital decoupling circuit comprising digital decoupling logic configured to electrically decouple the information element from the monitor; and

wherein at least one physiological sensor comprises a second information element configured to store additional cable management information, additional patient context information, or additional physiological information, wherein the digital decoupling circuit is further configured to electrically decouple the information element from the second information element.

2. The pulse oximetry system of claim 1, wherein the one or more decoupling circuits comprise an optocoupler in communication with the signal line.

3. The pulse oximetry system of claim 1, wherein the one or more decoupling circuits comprise a flyback transformer in communication with the power line.

4. The pulse oximetry system of claim 1, wherein the plurality of physiological sensors comprise an acoustic sensor.

5. A medical apparatus adapted to reduce the risk of electric shock to a medical patient when used with a physiological monitor, the apparatus comprising:

a plurality of physiological sensors, at least one of the physiological sensors comprising:

- a light emitter configured to impinge light on body tissue of a living patient, the body tissue including pulsating blood, and
- a detector responsive to the light after attenuation by the body tissue, wherein the detector is configured to generate a signal indicative of a physiological characteristic of the living patient;

a splitter cable operative to connect the plurality of physiological sensors to a physiological monitor, the splitter cable comprising a plurality of cable sections each comprising one or more electrical conductors configured to interface with one of the physiological sensors;

- one or more decoupling circuits disposed in the splitter cable, the one or more decoupling circuits being in communication with at least one electrical conductor, the one or more decoupling circuits configured to communicate physiological signals between one or more of the physiological sensors and the physiological monitor, the one or more decoupling circuits operative to electrically decouple the physiological sensors from each other;
- at least one information element configured to store cable management information, patient context information, or physiological information; and
- a digital decoupling circuit comprising digital decoupling logic; and

wherein at least one physiological sensor comprises a second information element configured to store additional cable management information, additional patient context information, or additional physiological information, wherein the digital decoupling circuit is configured to electrically decouple the information element from the second information element.

6. The apparatus of claim 5, wherein the one or more decoupling circuits comprise one or more of an optocoupler, a transformer, and an optical fiber.

7. The apparatus of claim 5, wherein the one or more decoupling circuits comprise one decoupling circuit disposed in a monitor connector of the splitter cable.

8. The apparatus of claim 5, wherein the one or more decoupling circuits comprise a plurality of decoupling circuits disposed in sensor connectors of the splitter cable.

9. The apparatus of claim 5, wherein the plurality of decoupling circuits are disposed in all but one of the cable sections.

10. The apparatus of claim 5, wherein the plurality of physiological sensors comprise an optical sensor and an acoustic sensor.

11. The apparatus of claim 5, further comprising a sensor detect circuit configured to provide an indication of a connection status of one of the sensors without polling the sensor.

12. The apparatus of claim 5, wherein one or more of the cable sections comprise a power line configured to supply power to one of the physiological sensors, a signal line configured to transmit the physiological signals from the physiological sensor to the physiological monitor, and a ground line configured to provide an electrical return path for the power line.

13. The apparatus of claim 12, wherein the one or more decoupling circuits are configured to substantially prevent ground loops from forming in the ground line.

14. A method of reducing the risk of electric shock to a medical patient as used with a pulse oximeter, the method comprising:

- providing a plurality of physiological sensors, at least one of the physiological sensors comprising a light emitter configured to impinge light on body tissue of a medical

27

patient and a detector configured to generate a signal indicative of a physiological characteristic of the living patient responsive to the light after attenuation by the body tissue;

providing a medical cable assembly comprising:

- an information element configured to store cable management information, patient context information, or physiological information; and
- a digital decoupling circuit comprising digital decoupling logic; and
- one or more electrical conductors configured to allow communication between the plurality of physiological sensors and a physiological monitor, such that the medical cable assembly is operative to provide signals representing physiological information of a medical patient from the plurality of physiological sensors to the physiological monitor;

electrically decoupling the plurality of physiological sensors from each other using one or more decoupling circuits disposed in the medical cable assembly, the one or more decoupling circuits being in communication with the plurality of physiological sensors and with the physiological monitor;

electrically decoupling the information element from the physiological monitor with the digital decoupling circuit;

wherein at least one physiological sensor comprises a second information element configured to store additional

28

cable management information, additional patient context information, or additional physiological information; and

electrically decoupling the information element from the second information element with the digital decoupling circuit.

15. The method of claim 14, wherein electrically decoupling the plurality of physiological sensors from each other comprises electrically decoupling the plurality of physiological sensor from each other using an optocoupler.

16. The method of claim 14, wherein electrically decoupling the plurality of physiological sensors from each other comprises electrically decoupling the plurality of physiological sensor from each other using a transformer.

17. The method of claim 14, further comprising providing an indication of a connection status of one of the sensors without polling the sensor.

18. The method of claim 14, wherein providing the medical cable assembly further comprises providing at least one sensor cable configured to be coupled with at least one of the physiological sensors and at least one instrument cable configured to be coupled with the at least one sensor cable and with the physiological monitor.

19. The method of claim 14, wherein providing the medical cable assembly comprises providing a splitter cable.

* * * * *

专利名称(译)	具有电去耦电路的脉搏血氧仪系统		
公开(公告)号	US9107625	公开(公告)日	2015-08-18
申请号	US12/436015	申请日	2009-05-05
[标]申请(专利权)人(译)	梅西莫股份有限公司		
申请(专利权)人(译)	Masimo公司		
当前申请(专利权)人(译)	Masimo公司		
[标]发明人	TELFORT VALERY G AL ALI AMMAR MARTEK PAUL		
发明人	TELFORT, VALERY G. AL-ALI, AMMAR MARTEK, PAUL		
IPC分类号	A61B5/00 A61B5/1455 H04B10/80 G02B6/43 G02B6/42 H04B10/00 H01R24/00 G02B6/00 H01R24/22		
CPC分类号	A61B5/14551 A61B5/14552 G02B6/43 G02B6/42 H04B10/802 A61B2560/045 A61B2562/08 A61B2562/222 A61B2562/227 H01R24/22 A61B5/7225 A61B2560/0276 A61B2560/0443 A61B2560/06		
审查员(译)	THOMSON, WILLIAM		
助理审查员(译)	ARCHER, MARIE		
优先权	61/050476 2008-05-05 US		
其他公开文献	US20090299157A1		
外部链接	Espacenet USPTO		

摘要(译)

用于降低对医疗患者的电击风险的脉搏血氧测定系统可以包括生理传感器，其中至少一个具有可以将光照射到活体患者的身体组织上的光发射器和响应于光衰减后的光的检测器。身体组织。检测器可以产生指示活体患者的生理特征的信号。脉搏血氧测量系统还可以包括分离器线缆，其可以将生理传感器连接到生理监测器。分路器线缆可以具有多个电缆部分，每个电缆部分包括一个或多个电导体，其可以与一个生理传感器连接。一个或多个去耦电路可以设置在分路器线缆中，其可以与所选择的电导体连通。一个或多个去耦电路可以电分离生理传感器。

