



US007499740B2

(12) **United States Patent**  
**Nordstrom et al.**

(10) **Patent No.:** **US 7,499,740 B2**  
(45) **Date of Patent:** **\*Mar. 3, 2009**

(54) **TECHNIQUES FOR DETECTING HEART PULSES AND REDUCING POWER CONSUMPTION IN SENSORS**

D250,275 S 11/1978 Bond  
D251,387 S 3/1979 Ramsey et al.

(75) Inventors: **Brad Nordstrom**, Alameda, CA (US);  
**William Shea**, Livermore, CA (US);  
**Ethan Petersen**, Castro Valley, CA (US)

(Continued)

FOREIGN PATENT DOCUMENTS

(73) Assignee: **Nellcor Puritan Bennett LLC**, Boulder, CO (US)

DE 3405444 8/1985

(\* ) Notice: Subject to any disclaimer, the term of this patent is extended or adjusted under 35 U.S.C. 154(b) by 72 days.

(Continued)

This patent is subject to a terminal disclaimer.

OTHER PUBLICATIONS

U.S. Appl. No. 11/525,636, filed Sep. 22, 2006, Hoarau.

(21) Appl. No.: **11/650,861**

(Continued)

(22) Filed: **Jan. 8, 2007**

*Primary Examiner*—Eric F Winakur  
*Assistant Examiner*—Etsub D Berhanu

(65) **Prior Publication Data**

US 2007/0208240 A1 Sep. 6, 2007

(57) **ABSTRACT**

**Related U.S. Application Data**

(63) Continuation of application No. 10/787,851, filed on Feb. 25, 2004, now Pat. No. 7,162,288.

(51) **Int. Cl.**  
**A61B 5/1455** (2006.01)

(52) **U.S. Cl.** ..... **600/323**

(58) **Field of Classification Search** ..... **600/300, 600/309, 322, 323, 324; 356/41; 359/239**  
See application file for complete search history.

Low power techniques for sensing cardiac pulses in a signal from a sensor are provided. A pulse detection block senses the sensor signal and determines its signal-to-noise ratio. After comparing the signal-to-noise ratio to a threshold, the drive current of light emitting elements in the sensor is dynamically adjusted to reduce power consumption while maintaining the signal-to-noise ratio at an adequate level. The signal component of the sensor signal can be measured by identifying systolic transitions. The systolic transitions are detected using a maximum and minimum derivative averaging scheme. The moving minimum and the moving maximum are compared to the scaled sum of the moving minimum and moving maximum to identify the systolic transitions. Once the signal component has been identified, the signal component is compared to a noise component to calculate the signal-to-noise ratio.

(56) **References Cited**

U.S. PATENT DOCUMENTS

3,403,555 A 10/1968 Versaci et al.  
3,536,545 A 10/1970 Traynor et al.  
D222,454 S 10/1971 Beeber  
3,721,813 A 3/1973 Condon et al.  
4,098,772 A 7/1978 Bonk et al.

**29 Claims, 3 Drawing Sheets**

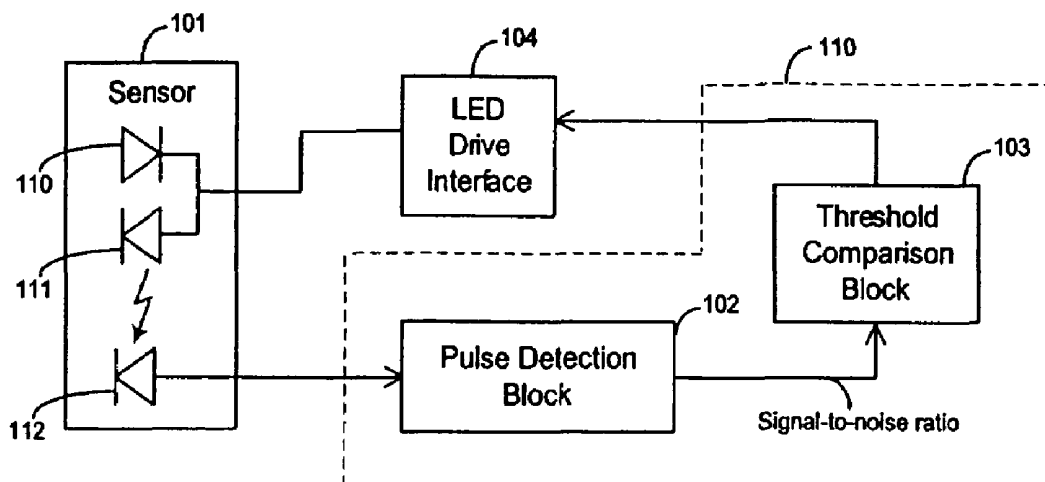

U.S. PATENT DOCUMENTS						
			5,007,423	A	4/1991	Branstetter et al.
D262,488	S	12/1981	5,025,791	A	6/1991	Niwa
4,334,544	A	6/1982	RE33,643	E	7/1991	Isaacson et al.
4,350,165	A	9/1982	5,028,787	A	7/1991	Rosenthal et al.
4,353,372	A	10/1982	5,035,243	A	7/1991	Muz
4,380,240	A	4/1983	5,040,539	A	8/1991	Schmitt et al.
4,406,289	A	9/1983	5,041,187	A	8/1991	Hink et al.
4,510,551	A	4/1985	5,054,488	A	10/1991	Muz
4,586,513	A	5/1986	5,055,671	A	10/1991	Jones
4,603,700	A	8/1986	5,058,588	A	10/1991	Kaestle
4,621,643	A	11/1986	5,065,749	A	11/1991	Hasebe et al.
4,653,498	A	3/1987	5,066,859	A	11/1991	Karkar et al.
4,677,528	A	6/1987	5,069,213	A	12/1991	Polczynski
4,685,464	A	8/1987	5,078,136	A	1/1992	Stone et al.
4,694,833	A	9/1987	5,086,229	A	2/1992	Rosenthal et al.
4,697,593	A	10/1987	5,088,493	A	2/1992	Giannini et al.
4,700,708	A	10/1987	5,090,410	A	2/1992	Saper et al.
4,714,080	A	12/1987	5,094,239	A	3/1992	Jaeb et al.
4,714,341	A	12/1987	5,094,240	A	3/1992	Muz
4,722,120	A	2/1988	5,099,841	A	3/1992	Heinonen et al.
4,726,382	A	2/1988	5,099,842	A	3/1992	Mannheimer et al.
4,759,369	A	7/1988	H1039	H	4/1992	Tripp et al.
4,770,179	A	9/1988	5,104,623	A	4/1992	Miller
4,773,422	A	9/1988	5,109,849	A	5/1992	Goodman et al.
4,776,339	A	10/1988	5,111,817	A	5/1992	Clark et al.
4,781,195	A	11/1988	5,113,861	A	5/1992	Rother
4,783,815	A	11/1988	D326,715	S	6/1992	Schmidt
4,796,636	A	1/1989	5,125,403	A	6/1992	Culp
4,800,495	A	1/1989	5,127,406	A	7/1992	Yamaguchi
4,800,885	A	1/1989	5,131,391	A	7/1992	Sakai et al.
4,802,486	A	2/1989	5,140,989	A	8/1992	Lewis et al.
4,805,623	A	2/1989	5,152,296	A	10/1992	Simons
4,807,630	A	2/1989	5,154,175	A	10/1992	Gunther
4,807,631	A	2/1989	5,158,082	A	10/1992	Jones
4,819,646	A	4/1989	5,170,786	A	12/1992	Thomas et al.
4,819,752	A	4/1989	5,188,108	A	2/1993	Secker et al.
4,824,242	A	4/1989	5,190,038	A	3/1993	Polson et al.
4,825,872	A	5/1989	5,193,542	A	3/1993	Missanelli et al.
4,825,879	A	5/1989	5,193,543	A	3/1993	Yelderman
4,830,014	A	5/1989	5,203,329	A	4/1993	Takatani et al.
4,832,484	A	5/1989	5,209,230	A	5/1993	Swedlow et al.
4,846,183	A	7/1989	5,213,099	A	5/1993	Tripp et al.
4,848,901	A	7/1989	5,216,598	A	6/1993	Branstetter et al.
4,854,699	A	8/1989	5,217,012	A	6/1993	Young et al.
4,859,056	A	8/1989	5,217,013	A	6/1993	Lewis et al.
4,859,057	A	8/1989	5,218,207	A	6/1993	Rosenthal
4,863,265	A	9/1989	5,218,962	A	6/1993	Mannheimer et al.
4,865,038	A	9/1989	5,224,478	A	7/1993	Sakai et al.
4,867,557	A	9/1989	5,226,417	A	7/1993	Swedlow et al.
4,869,253	A	9/1989	5,228,440	A	7/1993	Chung et al.
4,869,254	A	9/1989	5,237,994	A	8/1993	Goldberger
4,880,304	A	11/1989	5,239,185	A	8/1993	Ito et al.
4,883,055	A	11/1989	5,246,002	A	9/1993	Prosser
4,883,353	A	11/1989	5,246,003	A	9/1993	DeLonzor
4,890,619	A	1/1990	5,247,931	A	9/1993	Norwood
4,892,101	A	1/1990	5,247,932	A	9/1993	Chung et al.
4,901,238	A	2/1990	5,249,576	A	10/1993	Goldberger et al.
4,908,762	A	3/1990	5,253,645	A	10/1993	Friedman et al.
4,911,167	A	3/1990	5,253,646	A	10/1993	Delpy et al.
4,913,150	A	4/1990	5,259,381	A	11/1993	Cheung et al.
4,926,867	A	5/1990	5,259,761	A	11/1993	Schnettler et al.
4,927,264	A	5/1990	5,263,244	A	11/1993	Centa et al.
4,928,692	A	5/1990	5,267,562	A	12/1993	Ukawa et al.
4,934,372	A	6/1990	5,267,563	A	12/1993	Swedlow et al.
4,938,218	A	7/1990	5,267,566	A	12/1993	Choucair et al.
4,942,877	A	7/1990	5,273,036	A	12/1993	Kronberg et al.
4,948,248	A	8/1990	5,275,159	A	1/1994	Griebel
4,955,379	A	9/1990	5,278,627	A	1/1994	Aoyagi et al.
4,960,126	A	10/1990	5,279,295	A	1/1994	Martens et al.
4,964,408	A	10/1990	5,285,783	A	2/1994	Secker
4,971,062	A	11/1990	5,285,784	A	2/1994	Seeker
4,974,591	A	12/1990	5,287,853	A	2/1994	Vester et al.
			5,291,884	A	3/1994	Heinemann et al.

5,297,548 A	3/1994	Pologe	5,520,177 A	5/1996	Ogawa et al.
5,299,120 A	3/1994	Kaestle	5,521,851 A	5/1996	Wei et al.
5,299,570 A	4/1994	Hatschek	5,522,388 A	6/1996	Ishikawa et al.
5,309,908 A	5/1994	Friedman et al.	5,524,617 A	6/1996	Mannheimer
5,311,865 A	5/1994	Mayeux	5,529,064 A	6/1996	Rall et al.
5,313,940 A	5/1994	Fuse et al.	5,533,507 A	7/1996	Potratz et al.
5,323,776 A	6/1994	Blakely et al.	5,551,423 A	9/1996	Sugiura
5,329,922 A	7/1994	Atlee, III	5,551,424 A	9/1996	Morrison et al.
5,337,744 A	8/1994	Branigan	5,553,614 A	9/1996	Chance
5,339,810 A	8/1994	Ivers et al.	5,553,615 A	9/1996	Carim et al.
5,343,818 A	9/1994	McCarthy et al.	5,555,882 A	9/1996	Richardson et al.
5,343,869 A	9/1994	Pross et al.	5,558,096 A	9/1996	Palatnik
5,348,003 A	9/1994	Caro	5,560,355 A	10/1996	Merchant et al.
5,348,004 A	9/1994	Hollub et al.	5,564,417 A	10/1996	Chance
5,348,005 A	9/1994	Merrick et al.	5,575,284 A	11/1996	Athan et al.
5,349,519 A	9/1994	Kaestle	5,575,285 A	11/1996	Takanashi et al.
5,349,952 A	9/1994	McCarthy et al.	5,577,500 A	11/1996	Potratz
5,349,953 A	9/1994	McCarthy et al.	5,582,169 A	12/1996	Oda et al.
5,351,685 A	10/1994	Potratz	5,584,296 A	12/1996	Cui et al.
5,353,799 A	10/1994	Chance	5,588,425 A	12/1996	Sackner et al.
5,355,880 A	10/1994	Thomas et al.	5,588,427 A	12/1996	Tien
5,355,882 A	10/1994	Ukawa et al.	5,590,652 A	1/1997	Inai
5,361,758 A	11/1994	Hall et al.	5,595,176 A	1/1997	Yamaura
5,365,066 A	11/1994	Krueger, Jr. et al.	5,596,986 A	1/1997	Goldfarb
5,368,025 A	11/1994	Young et al.	5,611,337 A	3/1997	Bukta
5,368,026 A	11/1994	Swedlow et al.	5,617,852 A	4/1997	MacGregor
5,368,224 A	11/1994	Richardson et al.	5,619,992 A	4/1997	Guthrie et al.
5,372,136 A	12/1994	Steuer et al.	5,626,140 A	5/1997	Feldman et al.
5,377,675 A	1/1995	Ruskewicz et al.	5,629,992 A	5/1997	Amersfoort et al.
5,385,143 A	1/1995	Aoyagi	5,630,413 A	5/1997	Thomas et al.
5,387,122 A	2/1995	Goldberger et al.	5,632,272 A	5/1997	Diab et al.
5,390,670 A	2/1995	Centa et al.	5,632,273 A	5/1997	Suzuki
5,392,777 A	2/1995	Swedlow et al.	5,634,459 A	6/1997	Gardosi
5,398,680 A	3/1995	Polson et al.	5,638,593 A	6/1997	Gerhardt et al.
5,402,777 A	4/1995	Warring et al.	5,638,816 A	6/1997	Kiani-Azarbayjany et al.
5,402,779 A	4/1995	Chen et al.	5,638,818 A	6/1997	Diab et al.
5,411,023 A	5/1995	Morris, Sr. et al.	5,645,060 A	7/1997	Yorkey et al.
5,411,024 A	5/1995	Thomas et al.	5,645,440 A	7/1997	Tobler et al.
5,413,099 A	5/1995	Schmidt et al.	5,660,567 A	8/1997	Nierlich et al.
5,413,100 A	5/1995	Barthelemy et al.	5,662,105 A	9/1997	Tien
5,413,101 A	5/1995	Sugiura	5,662,106 A	9/1997	Swedlow et al.
5,413,102 A	5/1995	Schmidt et al.	5,664,270 A	9/1997	Bell et al.
5,417,207 A	5/1995	Young et al.	5,666,952 A	9/1997	Fuse et al.
5,421,329 A	6/1995	Casciani et al.	5,671,529 A	9/1997	Nelson
5,425,360 A	6/1995	Nelson	5,673,692 A	10/1997	Schulze et al.
5,425,362 A	6/1995	Siker et al.	5,673,693 A	10/1997	Solenberger
5,427,093 A	6/1995	Ogawa et al.	5,676,139 A	10/1997	Goldberger et al.
5,429,128 A	7/1995	Cadell et al.	5,676,141 A	10/1997	Hollub
5,429,129 A	7/1995	Lovejoy et al.	5,678,544 A	10/1997	DeLonzor et al.
5,431,159 A	7/1995	Baker et al.	5,680,857 A	10/1997	Pelikan et al.
5,431,170 A	7/1995	Mathews	5,685,299 A	11/1997	Diab et al.
5,437,275 A	8/1995	Amundsen et al.	5,685,301 A	11/1997	Klomhaus
5,438,986 A	8/1995	Disch et al.	5,687,719 A	11/1997	Sato et al.
5,448,991 A	9/1995	Polson et al.	5,687,722 A	11/1997	Tien et al.
5,452,717 A	9/1995	Branigan et al.	5,692,503 A	12/1997	Kuentner
5,465,714 A	11/1995	Scheuing	5,692,505 A	12/1997	Fouts
5,469,845 A	11/1995	DeLonzor et al.	5,709,205 A	1/1998	Bukta
RE35,122 E	12/1995	Corenman et al.	5,713,355 A	2/1998	Richardson et al.
5,482,034 A	1/1996	Lewis et al.	5,724,967 A	3/1998	Venkatachalam
5,482,036 A	1/1996	Diab et al.	5,727,547 A	3/1998	Levinson et al.
5,485,847 A	1/1996	Baker, Jr.	5,730,124 A	3/1998	Yamauchi
5,490,505 A	2/1996	Diab et al.	5,731,582 A	3/1998	West
5,490,523 A	2/1996	Isaacson et al.	D393,830 S	4/1998	Tobler et al.
5,491,299 A	2/1996	Naylor et al.	5,743,260 A	4/1998	Chung et al.
5,494,032 A	2/1996	Robinson et al.	5,743,262 A	4/1998	Lepper, Jr. et al.
5,494,043 A	2/1996	O'Sullivan et al.	5,743,263 A	4/1998	Baker, Jr.
5,497,771 A	3/1996	Rosenheimer	5,746,206 A	5/1998	Mannheimer
5,499,627 A	3/1996	Steuer et al.	5,746,697 A	5/1998	Swedlow et al.
5,503,148 A	4/1996	Pologe et al.	5,752,914 A	5/1998	DeLonzor et al.
5,505,199 A	4/1996	Kim	5,755,226 A	5/1998	Carim et al.
5,507,286 A	4/1996	Solenberger	5,758,644 A	6/1998	Diab et al.
5,511,546 A	4/1996	Hon	5,760,910 A	6/1998	Lepper, Jr. et al.
5,517,988 A	5/1996	Gerhard	5,766,125 A	6/1998	Aoyagi et al.

5,766,127 A	6/1998	Pologe et al.	5,924,982 A	7/1999	Chin
5,769,785 A	6/1998	Diab et al.	5,924,985 A	7/1999	Jones
5,772,587 A	6/1998	Gratton et al.	5,934,277 A	8/1999	Mortz
5,774,213 A	6/1998	Trebino et al.	5,934,925 A	8/1999	Tobler et al.
5,776,058 A	7/1998	Levinson et al.	5,940,182 A	8/1999	Lepper, Jr. et al.
5,776,059 A	7/1998	Kaestle	5,954,644 A	9/1999	Dettling et al.
5,779,630 A	7/1998	Fein et al.	5,957,840 A	9/1999	Terasawa et al.
5,779,631 A	7/1998	Chance	5,960,610 A	10/1999	Levinson et al.
5,782,237 A	7/1998	Casciani et al.	5,961,450 A	10/1999	Merchant et al.
5,782,756 A	7/1998	Mannheimer	5,961,452 A	10/1999	Chung et al.
5,782,757 A	7/1998	Diab et al.	5,964,701 A	10/1999	Asada et al.
5,782,758 A	7/1998	Ausec et al.	5,971,930 A	10/1999	Elghazzawi
5,786,592 A	7/1998	Hök	5,978,691 A	11/1999	Mills
5,788,634 A	8/1998	Suda et al.	5,978,693 A	11/1999	Hamilton et al.
5,790,729 A	8/1998	Pologe et al.	5,983,120 A	11/1999	Groner et al.
5,792,052 A	8/1998	Isaacson et al.	5,983,122 A	11/1999	Jarman et al.
5,795,292 A	8/1998	Lewis et al.	5,987,343 A	11/1999	Kinast
5,797,841 A	8/1998	DeLonzor et al.	5,991,648 A	11/1999	Levin
5,800,348 A	9/1998	Kaestle	5,995,855 A	11/1999	Kiani et al.
5,800,349 A	9/1998	Isaacson et al.	5,995,856 A	11/1999	Mannheimer et al.
5,803,910 A	9/1998	Potratz	5,995,858 A	11/1999	Kinast
5,807,246 A	9/1998	Sakaguchi et al.	5,995,859 A	11/1999	Takahashi
5,807,247 A	9/1998	Merchant et al.	5,997,343 A	12/1999	Mills et al.
5,807,248 A	9/1998	Mills	5,999,834 A	12/1999	Wang et al.
5,810,723 A	9/1998	Aldrich	6,002,952 A	12/1999	Diab et al.
5,810,724 A	9/1998	Gronvall	6,005,658 A	12/1999	Kaluza et al.
5,813,980 A	9/1998	Levinson et al.	6,006,120 A	12/1999	Levin
5,817,008 A	10/1998	Rafert et al.	6,011,985 A	1/2000	Athan et al.
5,817,009 A	10/1998	Rosenheimer et al.	6,011,986 A	1/2000	Diab et al.
5,817,010 A	10/1998	Hibl	6,014,576 A	1/2000	Raley et al.
5,818,985 A	10/1998	Merchant et al.	6,018,673 A	1/2000	Chin et al.
5,820,550 A	10/1998	Polson et al.	6,018,674 A	1/2000	Aronow
5,823,950 A	10/1998	Diab et al.	6,022,321 A	2/2000	Amano et al.
5,823,952 A	10/1998	Levinson et al.	6,023,541 A	2/2000	Merchant et al.
5,827,179 A	10/1998	Lichter et al.	6,026,312 A	2/2000	Shemwell et al.
5,827,182 A	10/1998	Raley et al.	6,026,314 A	2/2000	Amerov et al.
5,829,439 A	11/1998	Yokosawa et al.	6,031,603 A	2/2000	Fine et al.
5,830,135 A	11/1998	Bosque et al.	6,035,223 A	3/2000	Baker, Jr.
5,830,136 A	11/1998	DeLonzor et al.	6,036,642 A	3/2000	Diab et al.
5,830,137 A	11/1998	Scharf	6,041,247 A	3/2000	Weckstrom et al.
5,839,439 A	11/1998	Nierlich et al.	6,044,283 A	3/2000	Fein et al.
RE36,000 E	12/1998	Swedlow et al.	6,047,201 A	4/2000	Jackson, III
5,842,979 A	12/1998	Jarman et al.	6,055,447 A	4/2000	Well
5,842,981 A	12/1998	Larsen et al.	6,061,584 A	5/2000	Lovejoy et al.
5,842,982 A	12/1998	Mannheimer	6,064,898 A	5/2000	Aldrich
5,846,190 A	12/1998	Woehrl	6,064,899 A	5/2000	Fein et al.
5,851,178 A	12/1998	Aronow	6,067,462 A	5/2000	Diab et al.
5,851,179 A	12/1998	Ritson et al.	6,073,038 A	6/2000	Wang et al.
5,853,364 A	12/1998	Baker, Jr. et al.	6,078,829 A	6/2000	Uchida
5,860,919 A	1/1999	Kiani-Azarbayjany et al.	6,078,833 A	6/2000	Hueber
5,865,736 A	2/1999	Baker, Jr. et al.	6,081,735 A	6/2000	Diab et al.
5,879,294 A	3/1999	Anderson et al.	6,083,157 A	7/2000	Noller
5,885,213 A	3/1999	Richardson et al.	6,083,172 A	7/2000	Baker, Jr. et al.
5,890,929 A	4/1999	Mills et al.	6,088,607 A	7/2000	Diab et al.
5,891,021 A	4/1999	Dillon et al.	6,094,592 A	7/2000	Yorkey et al.
5,891,022 A	4/1999	Pologe	6,095,974 A	8/2000	Shemwell et al.
5,891,024 A	4/1999	Jarman et al.	6,104,938 A	8/2000	Huiku et al.
5,891,025 A	4/1999	Buschmann et al.	6,104,939 A	8/2000	Groner
5,891,026 A	4/1999	Wang et al.	6,112,107 A	8/2000	Hannula
5,902,235 A	5/1999	Lewis et al.	6,113,541 A	9/2000	Dias et al.
5,910,108 A	6/1999	Solenberger	6,115,621 A	9/2000	Chin
5,911,690 A	6/1999	Rall	6,122,535 A	9/2000	Kaestle et al.
5,912,656 A	6/1999	Tham et al.	6,133,994 A	10/2000	Mathews et al.
5,913,819 A	6/1999	Taylor et al.	6,135,952 A	10/2000	Coetzee
5,916,154 A	6/1999	Hobbs et al.	6,144,444 A	11/2000	Haworth et al.
5,916,155 A	6/1999	Levinson et al.	6,144,867 A	11/2000	Walker et al.
5,919,133 A	7/1999	Taylor et al.	6,144,868 A	11/2000	Parker
5,919,134 A	7/1999	Diab	6,149,481 A	11/2000	Wang et al.
5,920,263 A	7/1999	Huttenhoff et al.	6,151,107 A	11/2000	Schöllerman et al.
5,921,921 A	7/1999	Potratz et al.	6,151,516 A	11/2000	Kiani-Azarbayjani et al.
5,922,607 A	7/1999	Bernreuter	6,151,518 A	11/2000	Hayashi
5,924,979 A	7/1999	Swedlow et al.	6,152,754 A	11/2000	Gerhardt et al.
5,924,980 A	7/1999	Coetzee	6,154,667 A	11/2000	Miura et al.

6,157,850	A	12/2000	Diab et al.	6,393,311	B1	5/2002	Edgar, Jr. et al.
6,159,147	A	12/2000	Lichter	6,397,091	B2	5/2002	Diab et al.
6,163,715	A	12/2000	Larsen et al.	6,397,092	B1	5/2002	Norris et al.
6,165,005	A	12/2000	Mills et al.	6,397,093	B1	5/2002	Aldrich
6,173,196	B1	1/2001	Delonzor et al.	6,400,971	B1	6/2002	Finarov et al.
6,178,343	B1	1/2001	Bindszus et al.	6,400,972	B1	6/2002	Fine
6,179,159	B1	1/2001	Gurley	6,400,973	B1	6/2002	Winter
6,181,958	B1	1/2001	Steuer et al.	6,402,690	B1	6/2002	Rhee et al.
6,181,959	B1	1/2001	Schöllerman et al.	6,408,198	B1	6/2002	Hanna et al.
6,184,521	B1	2/2001	Coffin, IV et al.	6,411,832	B1	6/2002	Guthermann
6,188,470	B1	2/2001	Grace	6,411,833	B1	6/2002	Baker, Jr. et al.
6,192,260	B1	2/2001	Chance	6,421,549	B1	7/2002	Jacques
6,195,575	B1	2/2001	Levinson	6,430,423	B2	8/2002	DeLonzor et al.
6,198,951	B1	3/2001	Kosuda et al.	6,430,513	B1	8/2002	Wang et al.
6,206,830	B1	3/2001	Diab et al.	6,430,525	B1	8/2002	Weber et al.
6,213,952	B1	4/2001	Finarov et al.	6,434,408	B1	8/2002	Heckel et al.
6,217,523	B1	4/2001	Amano et al.	6,438,396	B1	8/2002	Cook
6,222,189	B1	4/2001	Misner et al.	6,438,399	B1	8/2002	Kurth
6,223,064	B1	4/2001	Lynn	6,449,501	B1	9/2002	Reuss
6,226,539	B1	5/2001	Potratz	6,453,183	B1	9/2002	Walker
6,226,540	B1	5/2001	Bernreuter et al.	6,453,184	B1	9/2002	Hyogo et al.
6,229,856	B1	5/2001	Diab et al.	6,456,862	B2	9/2002	Benni
6,230,035	B1	5/2001	Aoyagi et al.	6,461,305	B1	10/2002	Schnall
6,233,470	B1	5/2001	Tsuchiya	6,463,310	B1	10/2002	Swedlow et al.
6,236,871	B1	5/2001	Tsuchiya	6,463,311	B1	10/2002	Diab
6,236,872	B1	5/2001	Diab et al.	6,466,808	B1	10/2002	Chin et al.
6,240,305	B1	5/2001	Tsuchiya	6,466,809	B1	10/2002	Riley
6,253,097	B1	6/2001	Aronow et al.	6,470,199	B1	10/2002	Kopotic et al.
6,253,098	B1	6/2001	Walker et al.	6,470,200	B2	10/2002	Walker et al.
6,256,523	B1	7/2001	Diab et al.	6,480,729	B2	11/2002	Stone
6,256,524	B1	7/2001	Walker et al.	6,490,466	B1	12/2002	Fein et al.
6,261,236	B1	7/2001	Grimblatov	6,493,568	B1	12/2002	Bell
6,263,221	B1	7/2001	Chance et al.	6,496,711	B1	12/2002	Athan et al.
6,263,222	B1	7/2001	Diab et al.	6,498,942	B1	12/2002	Esenaliev et al.
6,263,223	B1	7/2001	Sheperd et al.	6,501,974	B2	12/2002	Huiku
6,266,546	B1	7/2001	Steuer et al.	6,501,975	B2	12/2002	Diab et al.
6,266,547	B1	7/2001	Walker et al.	6,505,060	B1	1/2003	Norris
6,272,363	B1	8/2001	Casciani et al.	6,505,061	B2	1/2003	Larson
6,278,522	B1	8/2001	Lepper, Jr. et al.	6,505,133	B1	1/2003	Hanna et al.
6,280,213	B1	8/2001	Tobler et al.	6,510,329	B2	1/2003	Heckel
6,280,381	B1	8/2001	Malin et al.	6,510,331	B1	1/2003	Williams et al.
6,285,894	B1	9/2001	Oppelt et al.	6,512,937	B2	1/2003	Blank et al.
6,285,895	B1	9/2001	Ristolainen et al.	6,515,273	B2	2/2003	Al-Ali
6,285,896	B1	9/2001	Tobler et al.	6,519,484	B1	2/2003	Lovejoy et al.
6,298,252	B1	10/2001	Kovach et al.	6,519,486	B1	2/2003	Edgar, Jr. et al.
6,308,089	B1	10/2001	Von der Ruhr et al.	6,519,487	B1	2/2003	Parker
6,321,100	B1	11/2001	Parker	6,525,386	B1	2/2003	Mills et al.
6,330,468	B1	12/2001	Scharf	6,526,300	B1	2/2003	Kiani et al.
6,334,065	B1	12/2001	Al-Ali et al.	6,526,301	B2	2/2003	Larsen et al.
6,339,715	B1	1/2002	Bahr et al.	6,541,756	B2	4/2003	Schulz et al.
6,342,039	B1	1/2002	Lynn	6,542,764	B1	4/2003	Al-Ali et al.
6,343,223	B1	1/2002	Chin et al.	6,546,267	B1	4/2003	Sugiura et al.
6,343,224	B1	1/2002	Parker	6,553,241	B2	4/2003	Mannheimer et al.
6,349,228	B1	2/2002	Kiani et al.	6,553,242	B1	4/2003	Sarussi
6,351,658	B1	2/2002	Middleman et al.	6,553,243	B2	4/2003	Gurley
6,353,750	B1	3/2002	Kimura	6,554,788	B1	4/2003	Hunley
6,356,774	B1	3/2002	Bernstein et al.	6,556,852	B1	4/2003	Schulze et al.
6,360,113	B1	3/2002	Dettling	6,560,470	B1	5/2003	Pologe
6,360,114	B1	3/2002	Diab et al.	6,564,077	B2	5/2003	Mortara
6,361,501	B1	3/2002	Amano et al.	6,564,088	B1	5/2003	Soller et al.
6,363,269	B1	3/2002	Hanna et al.	6,571,113	B1	5/2003	Fein et al.
D455,834	S	4/2002	Donars et al.	6,571,114	B1	5/2003	Koike et al.
6,370,408	B1	4/2002	Merchant et al.	6,574,491	B2	6/2003	Elghazzawi
6,370,409	B1	4/2002	Chung et al.	6,580,086	B1	6/2003	Schulz et al.
6,371,921	B1	4/2002	Caro	6,584,336	B1	6/2003	Ali et al.
6,374,129	B1	4/2002	Chin et al.	6,587,703	B2	7/2003	Cheng et al.
6,377,829	B1	4/2002	Al-Ali et al.	6,587,704	B1	7/2003	Fine et al.
6,381,479	B1	4/2002	Norris	6,589,172	B2	7/2003	Williams et al.
6,381,480	B1	4/2002	Stoddard et al.	6,591,122	B2	7/2003	Schmitt
6,385,471	B1	5/2002	Mortz	6,591,123	B2	7/2003	Fein et al.
6,385,821	B1	5/2002	Modgil et al.	6,594,511	B2	7/2003	Stone et al.
6,388,240	B2	5/2002	Schulz et al.	6,594,512	B2	7/2003	Huang
6,393,310	B1	5/2002	Kuenster	6,594,513	B1	7/2003	Jobsis et al.

6,597,931	B1	7/2003	Cheng et al.	6,731,963	B2	5/2004	Finarov et al.
6,597,933	B2	7/2003	Kiani et al.	6,731,967	B1	5/2004	Turcott
6,600,940	B1	7/2003	Fein et al.	6,735,459	B2	5/2004	Parker
6,606,510	B2	8/2003	Swedlow et al.	6,745,060	B2	6/2004	Diab et al.
6,606,511	B1	8/2003	Ali et al.	6,745,061	B1	6/2004	Hicks et al.
6,606,512	B2	8/2003	Muz et al.	6,748,253	B2	6/2004	Norris et al.
6,608,562	B1	8/2003	Kimura et al.	6,748,254	B2	6/2004	O'Neill et al.
6,609,016	B1	8/2003	Lynn	6,754,515	B1	6/2004	Pologe
6,615,064	B1	9/2003	Aldrich	6,754,516	B2	6/2004	Mannheimer
6,615,065	B1	9/2003	Barrett et al.	6,760,607	B2	7/2004	Al-Ali
6,618,602	B2	9/2003	Levin et al.	6,760,609	B2	7/2004	Jacques
6,622,034	B1	9/2003	Gorski et al.	6,760,610	B2	7/2004	Tscupp et al.
6,628,975	B1	9/2003	Fein et al.	6,763,255	B2	7/2004	DeLonzor et al.
6,631,281	B1	10/2003	Kästle	6,763,256	B2	7/2004	Kimball et al.
6,632,181	B2	10/2003	Flaherty	6,770,028	B1	8/2004	Ali et al.
6,640,116	B2	10/2003	Diab	6,771,994	B2	8/2004	Kiani et al.
6,643,530	B2	11/2003	Diab et al.	6,773,397	B2	8/2004	Kelly
6,643,531	B1	11/2003	Katarow	6,778,923	B2	8/2004	Norris et al.
6,647,279	B2	11/2003	Pologe	6,780,158	B2	8/2004	Yarita
6,647,280	B2	11/2003	Bahr et al.	6,791,689	B1	9/2004	Weckstrom
6,650,916	B2	11/2003	Cook	6,792,300	B1	9/2004	Diab et al.
6,650,917	B2	11/2003	Diab et al.	6,801,797	B2	10/2004	Mannheimer et al.
6,650,918	B2	11/2003	Terry	6,801,798	B2	10/2004	Geddes et al.
6,654,621	B2	11/2003	Palatnik et al.	6,801,799	B2	10/2004	Mendelson
6,654,622	B1	11/2003	Eberhard et al.	6,801,802	B2	10/2004	Sitzman et al.
6,654,623	B1	11/2003	Kästle	6,802,812	B1	10/2004	Walker et al.
6,654,624	B2	11/2003	Diab et al.	6,805,673	B2	10/2004	Dekker
6,658,276	B2	12/2003	Kianl et al.	6,810,277	B2	10/2004	Edgar, Jr. et al.
6,658,277	B2	12/2003	Wassermann	6,813,511	B2	11/2004	Diab et al.
6,662,033	B2	12/2003	Casciani et al.	6,816,741	B2	11/2004	Diab
6,665,551	B1	12/2003	Suzuki	6,819,950	B2	11/2004	Mills
6,668,182	B2	12/2003	Hubelbank	6,822,564	B2	11/2004	Al-Ali
6,668,183	B2	12/2003	Hicks et al.	6,825,619	B2	11/2004	Norris
6,671,526	B1	12/2003	Aoyagi et al.	6,826,419	B2	11/2004	Diab et al.
6,671,528	B2	12/2003	Steuer et al.	6,829,496	B2	12/2004	Nagai et al.
6,671,530	B2	12/2003	Chung et al.	6,830,711	B2	12/2004	Mills et al.
6,671,531	B2	12/2003	Al-Ali et al.	6,836,679	B2	12/2004	Baker, Jr. et al.
6,671,532	B1	12/2003	Fudge et al.	6,839,579	B1	1/2005	Chin
6,675,031	B1	1/2004	Porges et al.	6,839,580	B2	1/2005	Zonios et al.
6,678,543	B2	1/2004	Diab et al.	6,839,582	B2	1/2005	Heckel
6,681,126	B2	1/2004	Solenberger	6,839,659	B2	1/2005	Tarassenko et al.
6,681,128	B2	1/2004	Steuer et al.	6,842,635	B1	1/2005	Parker
6,681,454	B2	1/2004	Modgil et al.	6,845,256	B2	1/2005	Chin et al.
6,684,090	B2	1/2004	Ali et al.	6,850,787	B2	2/2005	Weber et al.
6,684,091	B2	1/2004	Parker	6,850,788	B2	2/2005	Al-Ali
6,694,160	B2	2/2004	Chin	6,850,789	B2	2/2005	Schweitzer, Jr. et al.
6,697,653	B2	2/2004	Hanna	6,861,639	B2	3/2005	Al-Ali
6,697,655	B2	2/2004	Sueppel et al.	6,863,652	B2	3/2005	Huang et al.
6,697,656	B1	2/2004	Al-Ali	6,865,407	B2	3/2005	Kimball et al.
6,697,658	B2	2/2004	Al-Ali	6,879,850	B2	4/2005	Kimball
RE38,476	E	3/2004	Diab et al.	6,882,874	B2	4/2005	Huiku
6,699,194	B1	3/2004	Diab et al.	6,898,452	B2	5/2005	Al-Ali et al.
6,699,199	B2	3/2004	Asada et al.	6,909,912	B2	6/2005	Melker et al.
6,701,170	B2	3/2004	Stetson	6,912,413	B2	6/2005	Rantala et al.
6,702,752	B2	3/2004	Dekker	6,920,345	B2	7/2005	Al-Ali et al.
6,707,257	B2	3/2004	Norris	6,931,269	B2	8/2005	Terry
6,708,049	B1	3/2004	Berson et al.	6,934,570	B2	8/2005	Kiani et al.
6,709,402	B2	3/2004	Dekker	6,941,162	B2	9/2005	Fudge et al.
6,711,424	B1	3/2004	Fine et al.	6,947,781	B2	9/2005	Asada et al.
6,711,425	B1	3/2004	Reuss	6,950,687	B2	9/2005	Al-Ali
6,712,762	B1	3/2004	Lichter	6,954,664	B2	10/2005	Sweitzer
6,714,803	B1	3/2004	Mortz	6,968,221	B2	11/2005	Rosenthal
6,714,804	B2	3/2004	Al-Ali et al.	6,979,812	B2	12/2005	Al-Ali
6,714,805	B2	3/2004	Jeon et al.	6,983,178	B2	1/2006	Fine et al.
RE38,492	E	4/2004	Diab et al.	6,985,763	B2	1/2006	Boas et al.
6,719,686	B2	4/2004	Coakley et al.	6,985,764	B2	1/2006	Mason et al.
6,719,705	B2	4/2004	Mills	6,990,426	B2	1/2006	Yoon et al.
6,720,734	B2	4/2004	Norris	6,992,751	B2	1/2006	Okita et al.
6,721,584	B2	4/2004	Baker, Jr. et al.	6,992,772	B2	1/2006	Block
6,721,585	B1	4/2004	Parker	6,993,371	B2	1/2006	Kiani et al.
6,725,074	B1	4/2004	Kästle	6,993,372	B2	1/2006	Fine et al.
6,725,075	B2	4/2004	Al-Ali	6,996,427	B2	2/2006	Ali et al.
6,731,962	B1	5/2004	Katarow	7,003,338	B2	2/2006	Weber et al.

7,003,339 B2	2/2006	Diab et al.	2004/0054291 A1	3/2004	Schulz et al.
7,006,855 B1	2/2006	Sarussi	2004/0068164 A1	4/2004	Diab et al.
7,006,856 B2	2/2006	Baker, Jr. et al.	2004/0092805 A1	5/2004	Yarita
7,016,715 B2	3/2006	Stetson	2004/0097797 A1	5/2004	Porges et al.
7,020,507 B2	3/2006	Scharf et al.	2004/0098009 A1	5/2004	Boecker et al.
7,024,233 B2	4/2006	Ali et al.	2004/0117891 A1	6/2004	Hannula et al.
7,024,235 B2	4/2006	Melker et al.	2004/0147824 A1	7/2004	Diab et al.
7,025,728 B2	4/2006	Ito et al.	2004/0158134 A1	8/2004	Diab et al.
7,027,849 B2	4/2006	Al-Ali	2004/0162472 A1	8/2004	Berson et al.
7,027,850 B2	4/2006	Wasserman	2004/0167381 A1	8/2004	Lichter
7,039,449 B2	5/2006	Al-Ali	2004/0186358 A1	9/2004	Chernow et al.
7,043,289 B2	5/2006	Fine et al.	2004/0204637 A1	10/2004	Diab et al.
7,047,055 B2	5/2006	Boas et al.	2004/0204638 A1	10/2004	Diab et al.
7,060,035 B2	6/2006	Wasserman	2004/0204639 A1	10/2004	Casciani et al.
7,062,307 B2	6/2006	Norris et al.	2004/0204865 A1	10/2004	Lee et al.
7,067,893 B2	6/2006	Mills et al.	2004/0210146 A1	10/2004	Diab et al.
7,072,701 B2	7/2006	Chen et al.	2004/0215085 A1	10/2004	Schnall
7,072,702 B2	7/2006	Edgar, Jr. et al.	2004/0236196 A1	11/2004	Diab et al.
7,079,880 B2	7/2006	Stetson	2005/0004479 A1	1/2005	Townsend et al.
7,085,597 B2	8/2006	Fein et al.	2005/0014999 A1	1/2005	Rahe-Meyer
7,096,052 B2	8/2006	Mason et al.	2005/0020887 A1	1/2005	Goldberg
7,096,054 B2	8/2006	Abdul-Hafiz et al.	2005/0033131 A1	2/2005	Chen
7,107,088 B2	9/2006	Aceti	2005/0043599 A1	2/2005	O'Mara
7,113,815 B2	9/2006	O'Neil et al.	2005/0043600 A1	2/2005	Diab et al.
7,123,950 B2	10/2006	Mannheimer	2005/0049468 A1	3/2005	Carlson
7,127,278 B2	10/2006	Melker et al.	2005/0070773 A1	3/2005	Chin
7,130,671 B2	10/2006	Baker, Jr. et al.	2005/0075546 A1	4/2005	Samsoondar
7,132,641 B2	11/2006	Schulz et al.	2005/0075550 A1	4/2005	Lindekugel
7,133,711 B2	11/2006	Chernoguz et al.	2005/0085704 A1	4/2005	Schulz
7,139,559 B2	11/2006	Kenagy et al.	2005/0090720 A1	4/2005	Wu
7,142,901 B2	11/2006	Kiani et al.	2005/0197548 A1	9/2005	Dietiker
7,162,288 B2	1/2007	Nordstrom et al.	2005/0228248 A1	10/2005	Dietiker
7,190,987 B2	3/2007	Lindekugel et al.	2005/0256386 A1	11/2005	Chan
7,198,778 B2	4/2007	Achilefu et al.	2005/0272986 A1	12/2005	Smith
7,215,984 B2	5/2007	Diab et al.	2005/0277819 A1	12/2005	Kiani et al.
7,225,006 B2	5/2007	Al-Ali et al.	2006/0020179 A1	1/2006	Anderson
7,228,161 B2	6/2007	Chin	2006/0030764 A1	2/2006	Porges
7,236,881 B2	6/2007	Schmitt et al.	2006/0058594 A1	3/2006	Ishizuka et al.
7,248,910 B2	7/2007	Li et al.	2006/0074280 A1	4/2006	Martis
7,254,433 B2	8/2007	Diab et al.	2006/0084852 A1	4/2006	Mason et al.
7,254,434 B2	8/2007	Schulz et al.	2006/0084878 A1	4/2006	Banet
7,280,858 B2	10/2007	Al-Ali et al.	2006/0089547 A1	4/2006	Sarussi
7,295,866 B2	11/2007	Al-Ali	2006/0106294 A1	5/2006	Maser et al.
7,305,262 B2	12/2007	Brodnick et al.	2006/0122517 A1	6/2006	Banet
7,315,753 B2	1/2008	Baker, Jr. et al.	2006/0129039 A1	6/2006	Lindner
2002/0016537 A1	2/2002	Muz et al.	2006/0155198 A1	7/2006	Schmid
2002/0026109 A1	2/2002	Diab et al.	2006/0173257 A1	8/2006	Nagai
2002/0028990 A1	3/2002	Sheperd et al.	2007/0060808 A1	3/2007	Hoarau
2002/0038078 A1	3/2002	Ito	2007/0073117 A1	3/2007	Haridan
2002/0042558 A1	4/2002	Mendelson	2007/0073121 A1	3/2007	Hoarau et al.
2002/0068859 A1	6/2002	Knopp	2007/0073122 A1	3/2007	Hoarau
2002/0072681 A1	6/2002	Schnall	2007/0073123 A1	3/2007	Raridan
2002/0116797 A1	8/2002	Modgil et al.	2007/0073125 A1	3/2007	Hoarau et al.
2002/0128544 A1	9/2002	Diab et al.	2007/0073126 A1	3/2007	Raridan
2002/0133067 A1	9/2002	Jackson, III	2007/0073128 A1	3/2007	Hoarau
2002/0156354 A1	10/2002	Larson	2007/0078315 A1	4/2007	Kling et al.
2002/0173706 A1	11/2002	Takatani	2007/0078316 A1	4/2007	Hoarau
2002/0190863 A1	12/2002	Lynn	2007/0260129 A1	11/2007	Chin
2003/0018243 A1	1/2003	Gerhardt et al.	2007/0260130 A1	11/2007	Chin
2003/0036690 A1	2/2003	Geddes et al.	2007/0260131 A1	11/2007	Chin
2003/0045785 A1	3/2003	Diab et al.	2007/0299328 A1	12/2007	Chin et al.
2003/0073889 A1	4/2003	Keilbach et al.			
2003/0073890 A1	4/2003	Hanna			
2003/0100840 A1	5/2003	Sugiura et al.			
2003/0187337 A1	10/2003	Tarassenko et al.	DE	3516338	11/1986
2003/0197679 A1	10/2003	Ali et al.	DE	37 03 458	8/1988
2003/0212316 A1	11/2003	Leiden et al.	DE	3938759	5/1991
2003/0225323 A1	12/2003	Kiani et al.	DE	4210102	9/1993
2004/0006261 A1	1/2004	Swedlow et al.	DE	4423597	8/1995
2004/0024326 A1	2/2004	Yeo et al.	DE	19632361	2/1997
2004/0030230 A1	2/2004	Norris	DE	69123448	5/1997
2004/0039272 A1	2/2004	Abdul-Hafiz et al.	DE	19703220	7/1997
2004/0039273 A1	2/2004	Terry	DE	19640807	9/1997

## FOREIGN PATENT DOCUMENTS

## US 7,499,740 B2

Page 8

---

DE	19647877	4/1998	JP	8256996	10/1996
DE	10030862	1/2002	JP	9192120	7/1997
DE	20318882	4/2004	JP	10216113	8/1998
EP	0127947	5/1984	JP	10216114	8/1998
EP	00194105	9/1986	JP	10216115	8/1998
EP	00204459	12/1986	JP	10337282	12/1998
EP	0 262 779	4/1988	JP	11019074	1/1999
EP	0315040	10/1988	JP	11155841	6/1999
EP	0314331	5/1989	JP	11 188019	7/1999
EP	0 360 977	4/1990	JP	11244268	9/1999
EP	00430340	6/1991	JP	20107157	4/2000
EP	0435 500	7/1991	JP	20237170	9/2000
EP	0572684	5/1992	JP	21245871	9/2001
EP	00497021	8/1992	JP	22224088	8/2002
EP	0529412	8/1992	JP	22282242	10/2002
EP	0531631	9/1992	JP	23153881	5/2003
EP	0566354	4/1993	JP	23153882	5/2003
EP	0587009	8/1993	JP	23169791	6/2003
EP	00630203	9/1993	JP	23194714	7/2003
EP	0 572 684	12/1993	JP	23210438	7/2003
EP	00615723	9/1994	JP	23275192	9/2003
EP	00702931	3/1996	JP	23339678	12/2003
EP	00724860	8/1996	JP	24008572	1/2004
EP	00793942	9/1997	JP	24089546	3/2004
EP	0 864 293	9/1998	JP	24113353	4/2004
EP	01006863	10/1998	JP	24135854	5/2004
EP	01006864	10/1998	JP	24148069	5/2004
EP	0875199	11/1998	JP	24148070	5/2004
EP	00998214	12/1998	JP	24159810	6/2004
EP	0898933	3/1999	JP	24166775	6/2004
EP	01332713	8/2003	JP	24194908	7/2004
EP	01469773	8/2003	JP	24202190	7/2004
EP	1502529	7/2004	JP	24248819	9/2004
EP	01491135	12/2004	JP	24248820	9/2004
FR	2685865	1/1992	JP	24261364	9/2004
GB	2 259 545	3/1993	JP	24290412	10/2004
JP	63275325	11/1988	JP	24290544	10/2004
JP	2013450	1/1990	JP	24290545	10/2004
JP	2111343	4/1990	JP	24329406	11/2004
JP	02 191434	7/1990	JP	24329607	11/2004
JP	2237544	9/1990	JP	24329928	11/2004
JP	03 173536	7/1991	JP	24337605	12/2004
JP	3170866	7/1991	JP	24344367	12/2004
JP	3245042	10/1991	JP	24351107	12/2004
JP	4174648	6/1992	JP	25034472	2/2005
JP	4191642	7/1992	WO	WO 89/09566	10/1989
JP	4332536	11/1992	WO	WO 90/01293	2/1990
JP	3124073	3/1993	WO	WO 90/04352	5/1990
JP	5049624	3/1993	WO	WO 91/01678	2/1991
JP	5049625	3/1993	WO	WO 91/11137	8/1991
JP	3115374	4/1993	WO	WO 92/00513	1/1992
JP	2005/200031	8/1993	WO	WO 92/21281	12/1992
JP	5212016	8/1993	WO	WO 93/09711	5/1993
JP	06014906	1/1994	WO	WO 93/13706	7/1993
JP	6016774	3/1994	WO	WO 93/16629	9/1993
JP	3116255	4/1994	WO	WO 94/03102	2/1994
JP	6029504	4/1994	WO	WO 94/23643	10/1994
JP	6098881	4/1994	WO	WO 95/02358	1/1995
JP	06 154177	6/1994	WO	WO 95/12349	5/1995
JP	6269430	9/1994	WO	WO 95/16970	6/1995
JP	6285048	10/1994	WO	WO 96/13208	5/1996
JP	7001273	1/1995	WO	WO 96/39927	12/1996
JP	7124138	5/1995	WO	WO 97/36536	10/1997
JP	7136150	5/1995	WO	WO 97/36538	10/1997
JP	3116259	6/1995	WO	WO 97/49330	12/1997
JP	3116260	6/1995	WO	WO 98/17174	4/1998
JP	7155311	6/1995	WO	WO 98/18382	5/1998
JP	7155313	6/1995	WO	WO 98/43071	10/1998
JP	3238813	7/1995	WO	WO 98/51212	11/1998
JP	7171139	7/1995	WO	WO 98/57577	12/1998
JP	3134144	9/1995	WO	WO 99/00053	1/1999
JP	7236625	9/1995	WO	WO 99/32030	7/1999
JP	7246191	9/1995	WO	WO 99/47039	9/1999



WO	WO 99/63884	12/1999
WO	WO 00/21438	4/2000
WO	WO 00/28888	5/2000
WO	WO 00/59374	10/2000
WO	WO 01/13790	3/2001
WO	WO 01/16577	3/2001
WO	WO 01/17421	3/2001
WO	WO 01/47426	3/2001
WO	WO 01/40776	6/2001
WO	WO 01/67946	9/2001
WO	WO 01/76461	10/2001
WO	WO 02/14793	2/2002
WO	WO 02/35999	5/2002
WO	WO 02/062213	8/2002
WO	WO 02/074162	9/2002
WO	WO 02/085202	10/2002
WO	WO 03/000125	1/2003
WO	WO 03/001180	1/2003
WO	WO 03/009750	2/2003
WO	WO 03/011127	2/2003
WO	WO 03/020129	3/2003
WO	WO 03/039326	5/2003
WO	WO 03/063697	8/2003
WO	WO 03/073924	9/2003
WO	WO 03/092490 A2	11/2003
WO	WO 04/000114	12/2003
WO	WO 2004/006748	1/2004
WO	WO 2004/069046	8/2004
WO	WO 2004/075746	9/2004
WO	WO 2005/002434	1/2005
WO	WO 2005/009221	2/2005
WO	WO 2005/010567	2/2005
WO	WO 2005/010568	2/2005
WO	WO 2005/020120	3/2005
WO	WO 2005/065540	7/2005

## OTHER PUBLICATIONS

- U.S. Appl. No. 11/525,704, filed Sep. 22, 2006, Hoarau.
- U.S. Appl. No. 11/525,693, filed Sep. 22, 2006, Hoarau.
- U.S. Appl. No. 11/525,396, filed Sep. 22, 2006, Hoarau.
- U.S. Appl. No. 11/525,635, filed Sep. 22, 2006, Hoarau.
- U.S. Appl. No. 11/507,814, filed Aug. 22, 2006, Baker Jr. et al.
- U.S. Appl. No. 11/527,762, filed Sep. 26, 2006, Ollerdesen.
- Rheineck-Leyssius, Aart t., et al.; "Advanced Pulse Oximeter Signal Processing Technology Compared to Simple Averaging: I. Effect on Frequency of Alarms in the Operating Room," *Journal of clinical Anesthesia*, vol. 11, pp. 192-195 (1990).
- Zahar, N., et al.; "Automatic Feedback Control of Oxygen Therapy Using Pulse Oximetry," *Annual International Conference of the IEEE Engineering in Medicine and Biology Society*, vol. 13, No. 4, pp. 1614-1615 (1991).
- Aoyagi, T., et al.; "Analysis of Motion Artifacts in Pulse Oximetry," *Japanese Society ME*, vol. 42, p. 20 (1993) (Article in Japanese—contains English summary of article).
- Barreto, A.B., et al.; "Adaptive Cancellation of Motion artifact in Photoplethysmographic Blood Volume Pulse Measurements for Exercise Evaluation," *IEEE-EMBC and CMBEC—Theme 4: Signal Processing*, pp. 983-984 (1995).
- Vincente, L.M., et al.; "Adaptive Pre-Processing of Photoplethysmographic Blood Volume Pulse Measurements," pp. 114-117 (1996).
- Plummer, John L., et al.; "Identification of Movement Artifact by the Nellcor N-200 and N-3000 Pulse Oximeters," *Journal of clinical Monitoring*, vol. 13, pp. 109-113 (1997).
- Barnum, P.T., et al.; "Novel Pulse Oximetry Technology Capable of Reliable Bradycardia Monitoring in the Neonate," *Respiratory Care*, vol. 42, No. 1, p. 1072 (Nov. 1997).
- Poets, C. F., et al.; "Detection of movement artifact in recorded pulse oximeter saturation," *Eur. J. Pediatr.*; vol. 156, pp. 808-811 (1997).
- Masin, Donald I., et al.; "Fetal Transmission Pulse Oximetry," *Proceedings 19<sup>th</sup> International Conference IEEE/EMBS*, Oct. 30-Nov. 2, 1997; pp. 2326-2329.
- Block, Frank E., Jr., et al.; "Technology evaluation report: Obtaining pulse oximeter signals when the usual probe cannot be used," *International journal of clinical Monitoring and Computing*, vol. 14, pp. 23-28 (1997).
- Nijland, Roel, et al.; "Validation of Reflectance Pulse Oximetry: An Evaluation of a new Sensor in Piglets," *Journal of Clinical Monitoring*, vol. 13, pp. 43-49 (1997).
- Soto, Denise A.; "A Comparative Study of Pulse Oximeter Measurements: Digit Versus Earlobe," Master of Science Thesis, California State University Dominguez Hills, May 1997, 46 pgs.
- Faisst, Karin, et al.; "Intrapartum Reflectance Pulse Oximetry: Effects of Sensor Location and Fixation Duration on Oxygen Saturation Readings," *Journal of Clinical Monitoring*, vol. 13, pp. 299-302 (1997).
- Izumi, Akio, et al.; "Accuracy and Utility of a New Reflectance Pulse Oximeter for Fetal Monitoring During Labor," *Journal of Clinical Monitoring*, vol. 13, pp. 103-108 (1997).
- Mannheimer, Paul, D., et al.; "Wavelength Selection for Low-Saturation Pulse Oximetry," *IEEE Transactions on Biomedical Engineering*, vol. 44, No. 3, pp. 148-158 (Mar. 1997).
- "Smaller Product, Tighter Tolerances Pose Dispensing Challenges for Medical Device Manufacturer," *Adhesives Age*, pp. 40-41 (Oct. 1997).
- Buschman, J.P., et al.; "Principles and Problems of Calibration of Fetal Oximeters," *Biomedizinische Technik*, vol. 42, pp. 265-266 (1997).
- Pickett, John, et al.; "Pulse Oximetry and PPG Measurements in Plastic Surgery," *Proceedings—19<sup>th</sup> International Conference—IEEE/EMBS*, Chicago, Illinois, Oct. 30-Nov. 2, 1997, pp. 2330-2332.
- Leahy, Martin J., et al.; "Sensor Validation in Biomedical Applications," *IFAC Modelling and Control in Biomedical Systems*, Warwick, UK; pp. 221-226 (1997).
- Barreto, Armando B., et al.; "Adaptive LMS Delay Measurement in dual Blood Volume Pulse Signals for Non-Invasive Monitoring," *IEEE*, pp. 117-120 (1997).
- Crilly, Paul B., et al.; "An Integrated Pulse Oximeter System for Telemedicine Applications," *IEEE Instrumentation and Measurement Technology Conference*, Ottawa, Canada; May 19-21, 1997; pp. 102-104.
- DeKock, Marc; "Pulse Oximetry Probe Adhesive Disks: a Potential for Infant Aspiration," *Anesthesiology*, vol. 89, pp. 1603-1604 (1998).
- East, Christine E., et al.; "Fetal Oxygen Saturation and Uterine Contractions During Labor," *American Journal of Perinatology*, vol. 15, No. 6, pp. 345-349 (Jun. 1998).
- Rhee, Sokwoo, et al.; "The Ring Sensor: a New Ambulatory Wearable Sensor for Twenty-Four Hour Patient Monitoring," *Proceedings of the 20<sup>th</sup> annual International Conference of the IEEE Engineering in Medicine and Biology Society*, vol. 20, No. 4, pp. 1906-1909 (Oct. 1998).
- Yang, Boo-Ho, et al.; "A Twenty-Four Hour Tele-Nursing System Using a Ring Sensor," *Proceedings of the 1998 IEEE International Conference on Robotics & Automation*, Leaven, Belgium, May 1998; pp. 387-392.
- König, Volker, et al.; "Reflectance Pulse Oximetry—Principles and Obstetric Application in the Zurich System," *Journal of Clinical Monitoring and Computing*, vol. 14, pp. 403-412 (1998).
- Nogawa, Masamichi, et al.; "A Novel Hybrid Reflectance Pulse Oximeter Sensor with improved Linearity and General Applicability to Various Portions of the Body," *Proceedings of the 20<sup>th</sup> Annual International Conference of the IEEE Engineering in Medicine and Biology Society*, vol. 20, No. 4, pp. 1858-1861 (1998).
- Hayes, Matthew J., et al.; "Quantitative evaluation of photoplethysmographic artifact reduction for pulse oximetry," *SPIE*, vol. 3570, pp. 138-147 (Sep. 1998).
- Edrich, Thomas, et al.; "Can the Blood Content of the Tissues be Determined Optically During Pulse Oximetry Without Knowledge of the Oxygen Saturation?—An In-Vitro Investigation," *Proceedings of the 20<sup>th</sup> Annual International conference of the IEEE Engineering in Medicine and Biology Society*, vol. 20, No. 6, pp. 3072-3075 (1998).

- Hayes, Matthew J., et al.; "Artifact reduction in photoplethysmography," *Applied Optics*, vol. 37, No. 31, pp. 7437-7446 (Nov. 1998).
- Such, Hans Olaf; "Optoelectronic Non-invasive Vascular Diagnostics Using multiple Wavelength and Imaging Approach," *Dissertation*, (1998).
- Lutter, N., et al.; "Comparison of Different Evaluation Methods for a Multi-wavelength Pulse Oximeter," *Biomedizinische Technik*, vol. 43, (1998).
- Ferrell, T.L., et al.; "Medical Telesensors," *SPIE*, vol. 3253, pp. 193-198 (1998).
- Todd, Bryan, et al.; "The Identification of Peaks in Physiological Signals," *Computers and Biomedical Research*, vol. 32, pp. 322-335 (1999).
- Rhee, Sokwoo, et al.; "Design of a Artifact-Free Wearable Plethysmographic Sensor," *Proceedings of the First joint BMES/EMBS Conference*, Oct. 13-16, 1999, Atlanta, Georgia, p. 786.
- Rohling, Roman, et al.; "Clinical Investigation of a New Combined Pulse Oximetry and Carbon Dioxide Tension Sensor in Adult Anaesthesia," *Journal of Clinical Monitoring and Computing*, vol. 15, pp. 23-27 (1999).
- Ikedo, Kenji, et al.; "Improvement of Photo-Electric Plethysmograph Applying Newly Developed Opto-Electronic Devices," *IEEE Tencon*, pp. 1109-1112 (1999).
- Kaestle, S.; "An Algorithm for Reliable Processing of Pulse Oximetry Signals Under strong Noise Conditions," *Dissertation Book*, Lubeck University, Germany (1999).
- Seelbach-Göbel, Birgit, et al.; "The prediction of fetal acidosis by means of intrapartum fetal pulse oximetry," *Am J. Obstet. Gynecol.*, vol. 180, No. 1, Part 1, pp. 73-81 (1999).
- Yang, Boo-Ho, et al.; "Development of the ring sensor for healthcare automation," *Robotics and Autonomous Systems*, vol. 30, pp. 273-281 (2000).
- Rhee, Sokwoo, et al.; "Artifact-Resistant, Power-Efficient Design of Finger-Ring Plethysmographic Sensor—Part I: Design and Analysis," *Proceedings of the 22<sup>nd</sup> Annual EMBS International Conference*, Chicago, Illinois, Jul. 23-28, 2000; pp. 2792-2795.
- Rhee, Sokwoo, et al.; "Artifact-Resistant, Power-Efficient Design of Finger-Ring Plethysmographic Sensor—Part II: Prototyping and Benchmarking," *Proceedings of the 22<sup>nd</sup> Annual EMBS International Conference*, Chicago, Illinois, Jul. 23-28, 2000; pp. 2796-2799.
- Vincenzi, Martin N.; "Transesophageal versus surface pulse oximetry in intensive care unit patients," *Crit. Care Med.*; vol. 28, No. 7, pp. 2268-2270 (2000).
- Goldman, Julian M.; "Masimo Signal Extraction Pulse Oximetry," *Journal of Clinical Monitoring and Computing*, vol. 16, pp. 475-483 (2000).
- Coetzee, Frans M.; "Noise-Resistant Pulse Oximetry Using a Synthetic Reference Signal," *IEEE Transactions on Biomedical Engineering*, vol. 47, No. 8, Aug. 2000, pp. 1018-1026.
- Nilsson, Lena, et al.; "Monitoring of Respiratory Rate in Postoperative Care Using a New Photoplethysmographic Technique," *Journal of Clinical Monitoring and Computing*, vol. 16, pp. 309-315 (2000).
- Nijland, Mark J.M., et al.; "Assessment of fetal scalp oxygen saturation determination in the sheep by transmission pulse oximetry," *Am. J. Obstet Gynecol.*, vol. 183, No. 6, pp. 1549-1553 (Dec. 2000).
- Edrich, Thomas, et al.; "Pulse Oximetry: An Improved In Vitro Model that Reduces Blood Flow-Related Artifacts," *IEEE Transactions on Biomedical Engineering*, vol. 47, No. 3, pp. 338-343 (Mar. 2000).
- Schulz, Christian Eric; "Design of a Pulse Oximetry Sensor Housing Assembly," California State University Master's Thesis, *UMI Dissertation Services*, UMI No. 1401306, (May 2000) 63 pages.
- Yao, Jianchu, et al.; "Design of a Plug-and-Play Pulse Oximeter," *Proceedings of the Second Joint EMBS/BMES Conference*, Houston, Texas, Oct. 23-26, 2002; pp. 1752-1753.
- Aoyagi, T., et al.; "Pulse Oximeters: background, present and future," *Neonatal Care*, vol. 13, No. 7, pp. 21-27 (2000) (Article in Japanese—contains English summary of article).
- Yokota, Nakaura, Takahashi, et al.; "Pilot Model of a Reflectance-Type Pulse Oximeter for Pre-hospital Evaluation," *Journal of the Japanese Society of Emergency Medicine*, Kanto Region, vol. 21, pp. 26-27 (2000) (Article in Japanese—contains English summary of article).
- Kaestle, S.; "Determining Artefact Sensitivity of New Pulse Oximeters in Laboratory Using Signals Obtained from Patient," *Biomedizinische Technik*, vol. 45 (2000).
- Cubeddu, Rinaldo, et al.; "Portable 8-channel time-resolved optical imager for functional studies of biological tissues," *Photon Migration, Optical Coherence Tomography, and Microscopy, Proceedings of SPIE*, vol. 4431, pp. 260-265 (2001).
- Gisiger, P.A., et al.; "OxiCarbo®, a single sensor for the non-invasive measurement of arterial oxygen saturation and CO<sub>2</sub> partial pressure at the ear lobe," *Sensor and Actuators*, vol. B-76, pp. 527-530 (2001).
- Cysewska-Sobusaik, Anna; "Metrological Problems With noninvasive Transillumination of Living Tissues," *Proceedings of SPIE*, vol. 4515, pp. 15-24 (2001).
- Rhee, Sokwoo, et al.; "Artifact-Resistant, Power-Efficient Design of Finger-Ring Plethysmographic Sensor," *IEEE Transactions on Biomedical Engineering*, vol. 48, No. 7, pp. 795-805 (Jul. 2001).
- Belal, Suliman Yousef, et al.; "A fuzzy system for detecting distorted plethysmogram pulses in neonates and paediatric patients," *Physiol. Meas.*, vol. 22, pp. 397-412 (2001).
- Hayes, Matthew J., et al.; "A New Method for Pulse Oximetry Possessing Inherent Insensitivity to Artifact," *IEEE Transactions on Biomedical Engineering*, vol. 48, No. 4, pp. 452-461 (Apr. 2001).
- Gosney, S., et al.; "An alternative position for the pulse oximeter probe," *Anaesthesia*, vol. 56, p. 493 (2001).
- Silva, Sonia Maria Lopez, et al.; "NIR transmittance pulse oximetry system with laser diodes," *Clinical Diagnostic Systems, Proceedings of SPIE*, vol. 4255, pp. 80-87 (2001).
- Maletras, Francois-Xavier, et al.; "Construction and calibration of a new design of Fiber Optic Respiratory Plethysmograph (FORP)," *Optomechanical Design and Engineering, Proceedings of SPIE*, vol. 4444, pp. 285-293 (2001).
- Earthrowl-Gould, T., et al.; "Chest and abdominal surface motion measurement for continuous monitoring of respiratory function," *Proc. Instn Mech Engrs*, V215, Part H, pp. 515-520 (2001).
- Gehring, Harmut, et al.; "The Effects of Motion Artifact and Low Perfusion on the Performance of a New Generation of Pulse Oximeters in Volunteers Undergoing Hypoxemia," *Respiratory Care*, Vol. 47, No. 1, pp. 48-60 (Jan. 2002).
- Jopling, Michae W., et al.; "Issues in the Laboratory Evaluation of Pulse Oximeter Performance," *Anesth Analg*, vol. 94, pp. S62-S68 (2002).
- Gostt, R., et al.; "Pulse Oximetry Artifact Recognition Algorithm for Computerized Anaesthetic Records," *Journal of Clinical Monitoring and Computing Abstracts*, p. 471 (2002).
- Chan, K.W., et al.; "17.3: Adaptive Reduction of Motion Artifact from Photoplethysmographic Recording using a Variable Step-Size LMS Filter," *IEEE*, pp. 1343-1346 (2002).
- Relente, A.R., et al.; "Characterization and Adaptive Filtering of Motion Artifacts in Pulse Oximetry using Accelerometers," *Proceedings of the Second joint EMBS/BMES Conference*, Houston, Texas, Oct. 23-26, 2002; pp. 1769-1770.
- Yamaya, Yoshiki, et al.; "Validity of pulse oximetry during maximal exercise in normoxia, hypoxia, and hyperoxia," *J. Appl. Physiol.*, vol. 92, pp. 162-168 (2002).
- Lutter, Norbert O., et al.; "False Alarm Rates of Three Third-Generation Pulse Oximeters in PACU, ICU and IABP Patients," *Anesth Analg*, vol. 94, pp. S69-S75 (2002).
- Lutter, N., et al.; "Accuracy of Noninvasive Continuous Blood Pressure; Measurement Utilising the Pulse Transit Time," *Journal of Clinical Monitoring and Computing*, vol. 17, Nos. 7-8, pp. 469 (2002).
- Liu, Ying, et al.; "Sensor design of new type reflectance pulse oximetry," *Optics in Health Care and Biomedical Optics: Diagnostics and Treatment, Proceedings of SPIE*, vol. 4916, pp. 98-102 (2002).
- Kyriacou, Panayiotis A., et al.; "Esophageal Pulse Oximetry Utilizing Reflectance Photoplethysmography," *IEEE Transactions on Biomedical Engineering*, vol. 49, No. 11, pp. 1360-1368 (Nov. 2002).
- Kyriacou, P. A., et al.; "Investigation of oesophageal photoplethysmographic signals and blood oxygen saturation mea-

- surements in cardiothoracic surgery patients," *Physiological Measurement*, vol. 23, No. 3, pp. 533-545 (Aug. 2002).
- Tobata, H., et al.; "Study of Ambient Light Affecting Pulse Oximeter Probes," *Ikigaku (Medical Technology)*, vol. 71, No. 10, pp. 475-476 (2002) (Article in Japanese—contains English summary of article).
- Irie, A., et al.; "Respiration Monitors—Pulse Oximeters," *Neonatal Care*, vol. 15, No. 12, pp. 78-83 (2002) (Article in Japanese—contains English summary of article).
- Koga, I., et al.; "Sigmoid colonic reflectance pulse oximetry and tonometry in a porcine experimental hypoperfusion shock model," *Acta Anaesthesiol Scand*, vol. 46, pp. 1212-1216 (2002).
- Shaltis, Phillip, et al.; "Implementation and Validation of a Power-Efficient, High-Speed Modulation Design for Wireless Oxygen Saturation Measurement Systems," *IEEE*, pp. 193-194 (2002).
- Warren, Steve, et al.; "Wearable Sensors and Component-Based Design for Home Health Care," *Proceedings of the Second Joint EMBS/BMES Conference*, Houston, Texas; Oct. 23-26, 2002; pp. 1871-1872.
- Ericson, M.N., et al.; "In vivo application of a minimally invasive oximetry based perfusion sensor," *Proceedings of the Second Joint EMBS/BMES Conference*, Houston, Texas; Oct. 23-26, 2002, pp. 1789-1790.
- Yoon, Gilwon, et al.; Multiple diagnosis based on Photoplethysmography: hematocrit, SpO<sub>2</sub>, pulse and respiration, *Optics in Health Care and Biomedical optics: Diagnostics and Treatment; Proceedings of the SPIE*, vol. 4916; pp. 185-188 (2002).
- Hase, Kentaro, et al.; "Continuous Measurement of Blood Oxygen Pressure Using a Fiber Optic Sensor Based on Phosphorescence Quenching," *Proceedings of the Second Joint EMBS/BMES Conference*, Houston, Texas; Oct. 23-26, 2002, pp. 1777-1778.
- Pothisarn, W., et al.; "A non-invasive hemoglobin measurement based pulse oximetry," *Optics in Health Care and Biomedical Optics: Diagnostics and Treatment; Proceedings of SPIE*, vol. 4916; pp. 498-504 (2002).
- Tremper, K.K.; "A Second Generation Technique for Evaluating Accuracy and Reliability of Second Generation Pulse Oximeters," *Journal of Clinical Monitoring and Computing*, vol. 16, pp. 473-474 (2002).
- Silva, Sonia Maria Lopez, et al.; "Near-infrared transmittance pulse oximetry with laser diodes," *Journal of Biomedical Optics*, vol. 8, No. 3, pp. 525-533 (Jul. 2003).
- Cyrill, D., et al.; "Adaptive Comb Filter for Quasi-Periodic Physiologic Signals," *Proceedings of the 25<sup>th</sup> Annual International Conference of the IEEE EMBS*, Cancun, Mexico, Sep. 17-21, 2003; pp. 2439-2442.
- Matthews, Nora S. et al.; "An evaluation of pulse oximeters in dogs, cats and horses," *Veterinary Anaesthesia and Analgesia*, vol. 30, pp. 3-14 (2003).
- Stetson, Paul F.; "Determining Heart Rate from Noisy Pulse Oximeter Signals Using Fuzzy Logic," *The IEEE International Conference on Fuzzy Systems*, St. Louis, Missouri, May 25-28, 2003; pp. 1053-1058.
- Aoyagi, Takuo; "Pulse oximetry: its invention, theory, and future," *Journal of Anesthesia*, vol. 17, pp. 259-266 (2003).
- Avidan, A.; "Pulse oximeter ear probe," *Anaesthesia*, vol. 58, pp. 726 (2003).
- Lee, C.M., et al.; "Reduction of motion artifacts from photoplethysmographic recordings using wavelet denoising approach," *IEEE EMBS Asian-Pacific Conference on Biomedical Engineering*, Oct. 20-22, 2003; pp. 194-195.
- Mendelson, Y., et al.; "Measurement Site and Photodetector Size Considerations in Optimizing Power Consumption of a Wearable Reflectance Pulse Oximeter," *Proceedings of the 25<sup>th</sup> Annual International conference of the IEEE EMBS*, Cancun, Mexico, Sep. 17-21, 2003; pp. 3016-3019.
- Itoh, K., et al.; "Pulse Oximeter," *Toyaku Zasshi (Toyaku Journal)*, vol. 25, No. 8, pp. 50-54 (2003) (Article in Japanese—contains English summary of article).
- Matsui, A., et al.; "Pulse Oximeter," *Neonatal Care*, vol. 16, No. 3, pp. 38-45 (2003) (Article in Japanese—contains English summary of article).
- Nakagawa, M., et al.; "Oxygen Saturation Monitor," *Neonatal Monitoring*, vol. 26, No. 5, pp. 536-539 (2003) (Article Japanese—contains English summary of article).
- Kubota, H., et al.; "Simultaneous Monitoring of PtcCO<sub>2</sub> and SpO<sub>2</sub> using a Miniature earlobe sensor," *Jinko Kokyo (Artificial Respiration)*, vol. 20, No. 1, pp. 24-29 (2003).
- Lebak, J.W., et al.; "Implementation of a Standards-Based Pulse Oximeter on a Wearable, Embedded Platform," *Proceedings of the 25<sup>th</sup> Annual International Conference of the IEEE EMBS*, Cancun, Mexico, Sep. 17-21, 2003; pp. 3196-3198.
- Nagl, L., et al.; "Wearable Sensor System for Wireless State-of-Health Determination in Cattle," *Proceedings of the 25<sup>th</sup> Annual International Conference of the IEEE EMBS*, Cancun, Mexico, Sep. 17-21, 2003; pp. 3012-3015.
- Östmark, Åke, et al.; "Mobile Medical Applications Made Feasible Through Use of EIS Platforms," *IMTC—Instrumentation and Measurement Technology Conference*, Vail, Colorado; May 20-22, 2003; pp. 292-295.
- Warren, Steve, et al.; "A Distributed Infrastructure for Veterinary Telemedicine," *Proceedings of the 25<sup>th</sup> Annual International Conference of the IEEE EMBS*, Cancun, Mexico; Sep. 17-21, 2003; pp. 1394-1397.
- Pujary, C., et al.; "Photodetector Size Considerations in the Design of a Noninvasive Reflectance Pulse Oximeter for Telemedicine Applications," *IEEE*, pp. 148-149 (2003).
- A. Johansson; "Neural network for photoplethysmographic respiratory rate monitoring," *Medical & Biological Engineering & Computing*, vol. 41, pp. 242-248 (2003).
- Reuss, James L.; "Factors Influencing Fetal Pulse Oximetry Performance," *Journal of clinical Monitoring and Computing*, vol. 18, pp. 13-14 (2004).
- Mannheimer, Paul D., et al.; "The influence of Larger Subcutaneous Blood Vessels on Pulse Oximetry," *Journal of clinical Monitoring and Computing*, vol. 18, pp. 179-188 (2004).
- Wendelken, Suzanne, et al.; "The Feasibility of Using a Forehead Reflectance Pulse Oximeter for Automated Remote Triage," *IEEE*, pp. 180-181 (2004).
- Lopez-Silva, S.M., et al.; "Transmittance Photoplethysmography and Pulse Oximetry With Near Infrared Laser Diodes," *IMTC 2004—Instrumentation and Measurement Technology Conference*, Como, Italy, May 18-20, 2004; pp. 718-723.
- Sugino, Shigezau, et al.; "Forehead is as sensitive as finger pulse oximetry during general anesthesia," *Can J. Anesth.; General Anesthesia*, vol. 51, No. 5; pp. 432-436 (2004).
- Addison, Paul S., et al.; "A novel time-frequency-based 3D Lissajous figure method and its application to the determination of oxygen saturation from the photoplethysmogram," *Institute of Physics Publishing, Meas. Sci. Technol.*, vol. 15, pp. L15-L18 (2004).
- Jovanov, E., et al.; "Reconfigurable intelligent Sensors for Health Monitoring: A case Study of Pulse Oximeter Sensor," *Proceedings of the 26<sup>th</sup> Annual International conference of the IEEE EMBS*, San Francisco, California, Sep. 1-5, 2004, pp. 4759-4762.
- Kocher, Serge, et al.; "Performance of a Digital PCO<sub>2</sub>/SPO<sub>2</sub> Ear Sensor," *Journal of Clinical Monitoring and Computing*, vol. 18, pp. 75-79 (2004).
- Yao, Jianchu, et al.; "A Novel Algorithm to Separate Motion Artifacts from Photoplethysmographic Signals Obtained With a Reflectance Pulse Oximeter," *Proceedings of the 26<sup>th</sup> Annual International conference on the IEEE EMBS*, San Francisco, California, Sep. 1-5, 2004; pp. 2153-2156.
- Nuhr, M., et al.; "Forehead SpO<sub>2</sub> monitoring compared to finger SpO<sub>2</sub> recording in emergency transport," *Anaesthesia*, vol. 59, pp. 390-393 (2004).
- Johnston, William S., et al.; "Effects of Motion Artifacts on helmet-Mounted Pulse Oximeter Sensors," 2 pgs. (2004).
- Branche, Paul C., et al.; "Measurement Reproducibility and Sensor Placement Considerations in Designing a Wearable Pulse Oximeter for Military Applications," 2 pgs. (2004).
- Kocher, Serge, et al.; "Performance of a Digital PCO<sub>2</sub>/SPO<sub>2</sub> Ear Sensor," *Journal of Clinical Monitoring and Computing*, vol. 18, pp. 75-79 (2004).

- Heuss, Ludwig T., et al.; "Combined Pulse Oximetry / Cutaneous Carbon dioxide Tension Monitoring During Colonoscopies: Pilot study with a Smart Ear Clip," *Digestion*, vol. 70, pp. 152-158 (2004).
- Matsuzawa, Y., et al.; "Pulse Oximeter," *Home Care Medicine*, pp. 42-45 (Jul. 2004); (Article in Japanese—contains English summary of article).
- Crespi, F., et al.; "Near infrared oximeter prototype for non-invasive analysis of rat brain oxygenation," *Optical Sensing, Proceedings of SPIE*, vol. 5459, pp. 38-45 (2004).
- Johnston, W.S., et al.; "Extracting Breathing Rate Information from a Wearable Reflectance Pulse Oximeter Sensor," *Proceedings of the 26<sup>th</sup> Annual International conference of the IEEE EMBS*, San Francisco, California; Sep. 1-5, 2004; pp. 5388-5391.
- Spigulis, Janis, et al.; "Optical multi-channel sensing of skin blood pulsations," *Optical Sensing, Proceedings of SPIE*, vol. 5459, pp. 46-53 (2004).
- Yan, Yong-sheng, et al.; "Reduction of motion artifact in pulse oximetry by smoothed pseudo Wigner-Ville distribution," *Journal of NeuroEngineering and Rehabilitation*, vol. 2, No. 3 (9 pages) (Mar. 2005).
- Urquhart, C., et al.; "Ear probe pulse oximeters and neonates," *Anaesthesia*, vol. 60, p. 294 (2005).
- J. Hayoz, et al.; "World's First Combined digital Pulse Oximetry Pulse Oximetry and Carbon Dioxide Tension Ear Sensor", *Abstracts*, A6, p. S103, undated.
- J. Huang, et al.; "Low Power Motion Tolerant Pulse Oximetry," *Abstracts*, A7, p. S103, undated.
- P. Lang, et al.; "Signal Identification and Quality Indicator™ for Motion Resistant Pulse Oximetry," *Abstracts*, A10, p. S105, undated.
- Hamilton, Patrick S., et al.; "Effect of Adaptive Motion-Artifact Reduction on QRS Detection," *Biomedical Instrumentation & Technology*, pp. 197-202, undated.
- Kim, J.M., et al.; "Signal Processing Using Fourier & Wavelet Transform," pp. 11-310-11-311, undated.
- Lee, C.M., et al.; "Reduction of Motion Artifacts from Photoplethysmographic Records Using a Wavelet Denoising Approach," *IEEE*, pp. 194-195, undated.
- Nogawa, Masamichi, et al.; "A New Hybrid Reflectance Optical Pulse Oximetry Sensor for Lower Oxygen Saturation Measurement and for Broader Clinical Application," *SPIE*, vol. 2976, pp. 78-87, undated.
- Odagiri, Y.; "Pulse Wave Measuring Device," *Micromechanics*, vol. 42, No. 3, pp. 6-11 (undated) (Article in Japanese—contains English summary of article).
- Yamazaki, Nakaji, et al.; "Motion Artifact Resistant Pulse Oximeter (Durapulse PA 2100)," *Journal of Oral Cavity Medicine*, vol. 69, No. 4, pp. 53 (date unknown) (Article in Japanese—contains English summary of article).

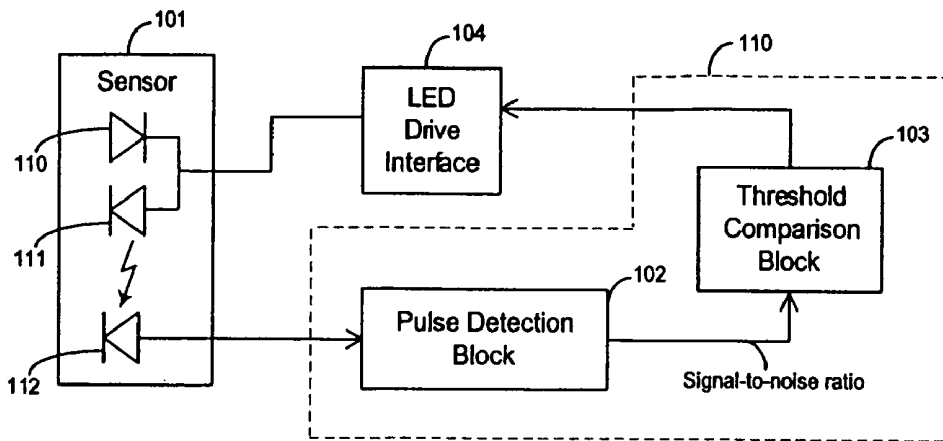

FIG. 1

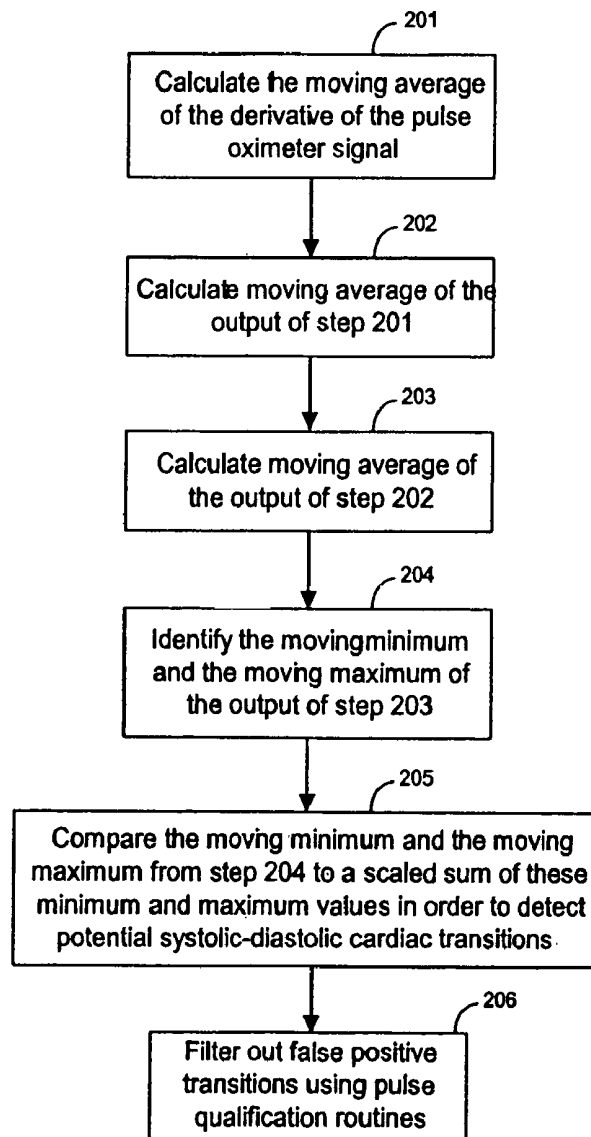

FIG. 2

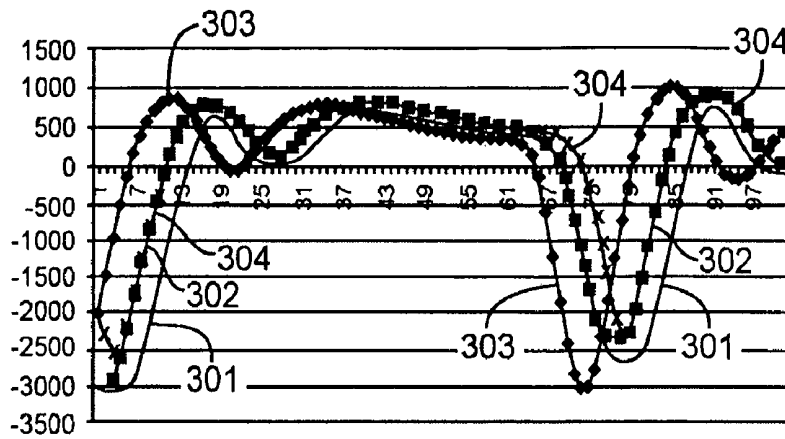

FIG. 3A

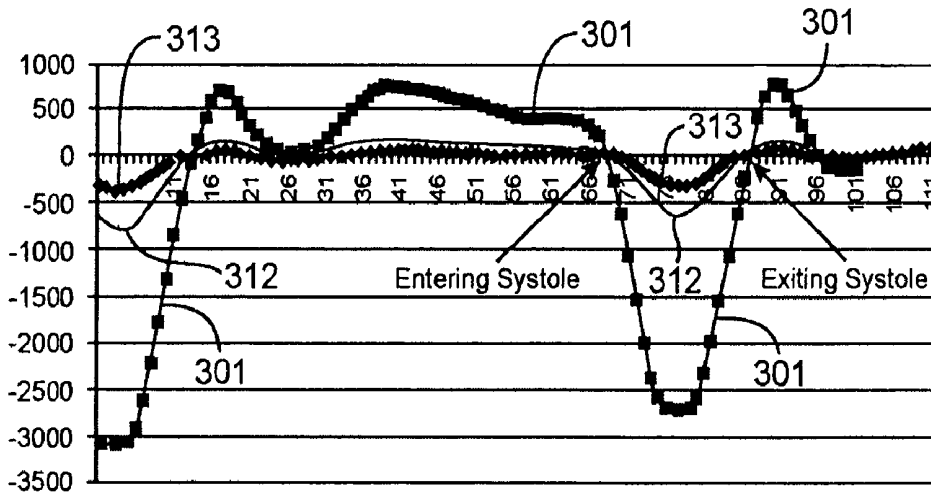

FIG. 3B

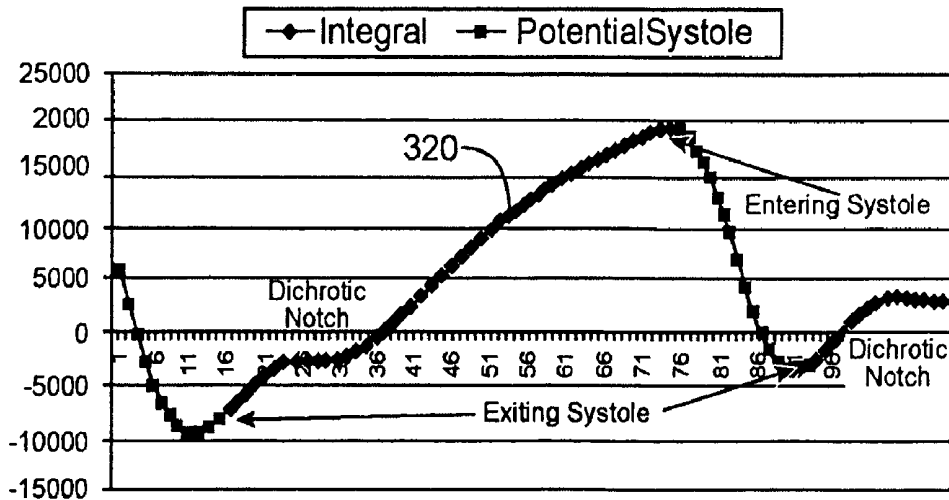

FIG. 3C

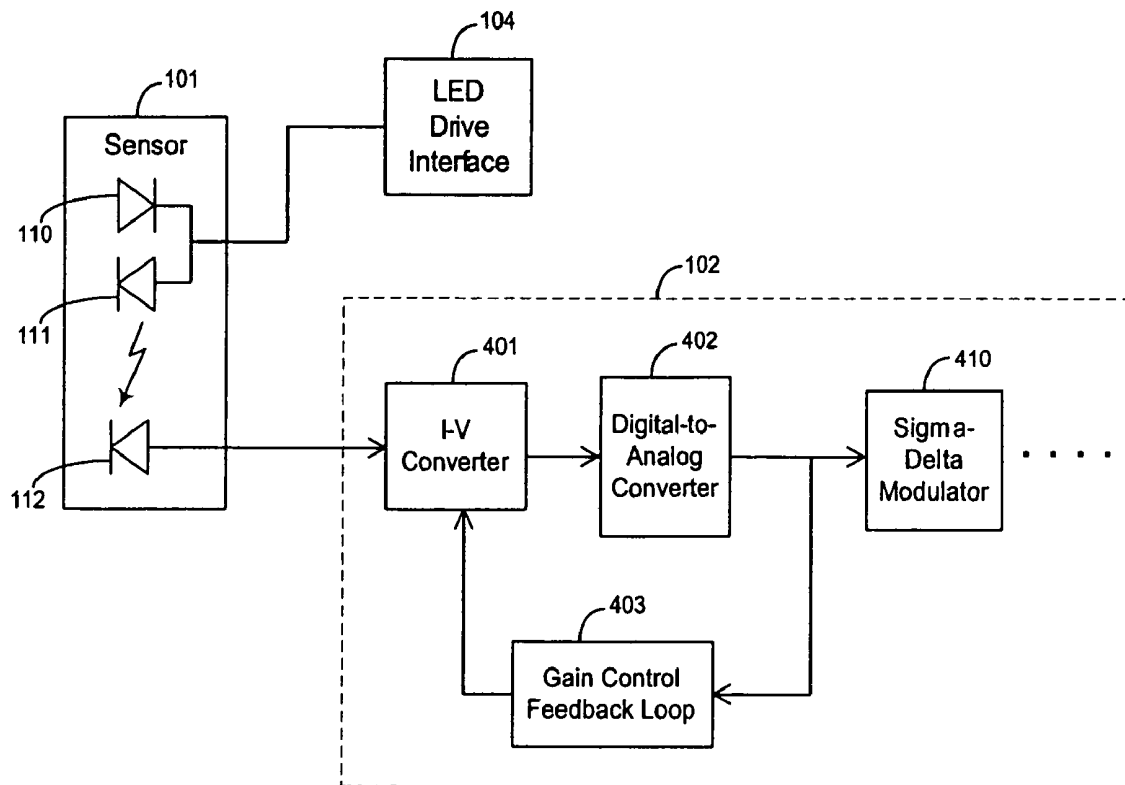

FIG. 4

# TECHNIQUES FOR DETECTING HEART PULSES AND REDUCING POWER CONSUMPTION IN SENSORS

## CROSS-REFERENCE TO RELATED APPLICATIONS

This application is a continuation of application Ser. No. 10/787,851, filed Feb. 25, 2004, now U.S. Pat. No. 7,162,288.

## BACKGROUND OF THE INVENTION

The present invention relates to techniques for detecting heart pulses and reducing power consumption in sensors and oximeter systems, and more particularly, to techniques for distinguishing heart pulses in a sensor signal from noise and adjusting drive current provided to light emitting elements in response to a signal-to-noise ratio of the pulse in order to reduce power consumption.

Pulse oximetry is a technology that is typically used to measure various blood chemistry characteristics including, but not limited to, the blood-oxygen saturation of hemoglobin in arterial blood, the volume of individual blood pulsations supplying the tissue, and the rate of blood pulsations corresponding to each heartbeat of a patient.

Measurement of these characteristics has been accomplished by use of a non-invasive sensor. The sensor has a light source such as a light emitting diode (LED) that scatters light through a portion of the patient's tissue where blood perfuses the tissue. The sensor also has a photodetector that photoelectrically senses the absorption of light at various wavelengths in the tissue. The photodetector generates a pulse oximeter signal that indicates the amount of light absorbed by the blood. The amount of light absorbed is then used to calculate the amount of blood constituent being measured.

The light scattered through the tissue is selected to be of one or more wavelengths that are absorbed by the blood in an amount representative of the amount of the blood constituent present in the blood. The amount of transmitted light scattered through the tissue will vary in accordance with the changing amount of blood constituent in the tissue and the related light absorption.

For measuring blood oxygen level, oximeter sensors typically have a light source that is adapted to generate light of at least two different wavelengths, and with photodetectors sensitive to these wavelengths, in accordance with known techniques for measuring blood oxygen saturation. A typical pulse oximeter will alternately illuminate the patient with red and infrared light using two LEDs to obtain two different detector signals.

The pulse oximeter signal generated by the photodetector usually contains components of noise introduced by the electronics of the oximeter, by the patient, and by the environment. Noisy signals have a low signal-to-noise ratio. A pulse oximeter cannot accurately identify the blood oxygen saturation when the signal-to-noise ratio of the pulse oximeter signal is too low.

To improve the signal-to-noise ratio of the pulse oximeter signal, a pulse oximeter system will typically drive the LEDs with a large amount of current. A servo in the pulse oximeter will typically drive as much current as possible through the LEDs without causing the oximeter to be over-ranged (i.e., driven to full rail). The large drive current causes the LEDs to generate more light and to consume more power. Because the photodetector is able to sense more of the light from the LEDs, the signal-to-noise ratio of the pulse oximeter signal is higher.

Increasing the drive current of the LEDs to improve the signal-to-noise ratio of the pulse oximeter signal causes the system to consume an undesirably large amount of power. The large amount of power consumption can be a problem for oximeter systems that are battery operated.

It would therefore be desirable to provide pulse oximeter systems that consume less power without negatively compromising the signal-to-noise ratio of the pulse oximeter signal.

## BRIEF SUMMARY OF THE INVENTION

The present invention provides CPU cycle efficient techniques for sensing heart pulses in a signal from a sensor. The sensor signal can be, for example, a pulse oximeter signal generated by a photodetector in a pulse oximeter sensor. The signal component of the sensor signal is measured by identifying potential systolic transitions of the cardiac cycle. The systolic transitions are detected using a derivative averaging scheme. The moving minimum and the moving maximum of the average derivative are compared to a scaled sum of the minimum and maximum to identify the systolic transitions. The systolic transitions correspond to a signal component of the sensor signal. The signal component is compared to a noise component to determine the signal-to-noise ratio of the signal.

The present invention also provides techniques for reducing power consumption in a sensor. After the signal-to-noise ratio of the pulse oximeter has been determined, the signal-to-noise ratio is compared to a threshold. In response to the output of the comparison, the drive current of light emitting elements in the sensor is dynamically adjusted to reduce power consumption and to maintain the signal-to-noise ratio at an adequate level for signal processing.

The present invention also provides techniques for sensing and adjusting the gain of a transimpedance amplifier to reduce the effect of ambient noise in a sensor. A gain control feedback loop senses the magnitude of the sensor signal when the light emitting elements are off. The gain control loop can include this information to effectively control the gain of the transimpedance amplifier.

For a further understanding of the nature and advantages of the invention, reference should be made to the following description taken in conjunction with the accompanying drawings.

## BRIEF DESCRIPTION OF THE DRAWINGS

FIG. 1 illustrates a block diagram of a pulse oximeter system with reduced power consumption according to an embodiment of the present invention;

FIG. 2 is a flow chart that illustrates a process for identifying the systolic period of a pulse oximeter signal according to an embodiment of the present invention;

FIGS. 3A-3C are graphs that illustrates how systolic transitions are identified in pulse oximeter signals according to embodiments of the present invention; and

FIG. 4 illustrates a portion of a pulse oximeter system with a transimpedance amplifier, a sigma-delta modulator, an analog-to-digital converter, and a gain control feedback loop according to an embodiment of the present invention.

## DETAILED DESCRIPTION OF THE INVENTION

The techniques of the present invention can be used in the context of a pulse oximeter system. A pulse oximeter system receives a pulse oximeter signal from a photodetector in a pulse oximeter sensor. FIG. 1 illustrates a block diagram of



pulse oximeter system according to an embodiment of the present invention. The pulse oximeter system includes an oximeter sensor **101**.

An oximeter sensor of the present invention can utilize any suitable number of light emitting elements. For example, a sensor of the present invention can have 1, 2, 3, or 4 light emitting elements. In the example of FIG. 1, sensor **101** has two LEDs **110** and **111** that emit two different wavelengths of light.

Sensor **101** also includes photodetector **112** that senses light from LEDs **110** and **111** after the light has passed through the patient's tissue. The pulse oximeter system also includes feedback loop circuitry **110** and LED drive interface **104**. Feedback loop circuitry **110** includes pulse detection block **102** and threshold comparison block **103**.

Photodetector **112** transmits the pulse oximeter signal to pulse detection block **102**. Pulse detection block **102** has a servo that measures the signal component of the pulse oximeter signal by identifying the systolic transitions. The pulse detection block **102** and the threshold comparison block **103** form a feedback loop **110** around the sensor to control the drive current of the LEDs and the signal-to-noise ratio of the pulse oximeter signal, as will be discussed in detail below.

A cardiac pulse can be divided into a diastolic and systolic period. The systolic period is typically characterized by a rapid change in value due to the contraction of the heart. The diastolic period is typically characterized by a gradual change in value, due to the relaxation and refilling of the heart chambers.

Systolic transitions in the pulse oximeter signal are detected using a three step maximum and minimum derivative averaging scheme, which is discussed in further detail below. Qualification routines are then used to filter out false positives. The resulting data contains the systolic transitions separated from the non-systolic periods in the pulse oximeter signal.

Pulse detection block **102** then compares the amplitude of the systolic portion of the pulse oximeter signal to a noise component to generate a value for the signal-to-noise ratio of the pulse oximeter signal. Subsequently, threshold comparison block **103** compares this signal-to-noise ratio to a threshold level to determine whether the signal-to-noise ratio is high enough such that the pulse oximeter signal can be used to accurately calculate pulse rate and oxygen saturation. Too much noise obscures the pulse rate and oxygen saturation information in the signal. Noise can degrade the signal to the point that it cannot be used to accurately calculate pulse rate or oxygen saturation.

Threshold comparison block **103** preferably contains two hysteresic threshold levels. In this embodiment, threshold comparison block **103** senses whether the signal-to-noise ratio is greater than a maximum threshold level or less than a minimum threshold level. As an example, the maximum threshold level can represent a signal-to-noise ratio of 128:1, and the minimum threshold level can represent a signal-to-noise ratio of 8:1. These are merely two examples of threshold levels. They are not intended to limit the scope of the present invention. Prior art oximeter systems, for example, operate at a signal-to-noise ratio of 10,000:1 or higher, because they drive the LEDs as bright as possible.

If the signal-to-noise ratio is greater than the maximum threshold level, threshold comparison block **103** sends a signal to LED drive interface **104** to reduce the LED current. Based on the value of the signal-to-noise ratio, threshold comparison block **103** can determine how much the LED drive current needs to be reduced to decrease the signal-to-noise ratio while maintaining the signal level within the mini-

imum and maximum threshold levels. LED drive interface **104** responds by decreasing the LED drive current to the value indicated by threshold comparison block **103**.

The feedback loop continuously monitors the signal-to-noise ratio of the pulse oximeter signal and dynamically adjusts the LED drive current and subsequent system gain until the signal-to-noise ratio is less than the maximum threshold. The oximeter system saves power by substantially reducing the LED drive current (relative to prior art systems), while maintaining the signal-to-noise ratio of the pulse oximeter signal within an acceptable range.

The signal-to-noise ratio can also drop too low for a number of reasons. For example, the noise in the pulse oximeter may increase, or the strength of the signal component may decrease if the blood oxygen saturation of the patient decreases. In any event, the system of FIG. 1 senses when the magnitude of the pulse oximeter signal is too low and increases the LED drive current accordingly.

If the signal-to-noise ratio is less than the minimum threshold level, threshold comparison block **103** sends a signal to LED drive interface **104** to increase the LED current. Based on the value of the signal-to-noise ratio, the threshold comparison can determine how much the LED drive current needs to be increased to increase the signal-to-noise ratio while maintaining the signal within the minimum and maximum threshold levels. LED drive interface **104** responds by increasing the LED drive current to the value indicated by the threshold comparison system.

The feedback loop continuously monitors the signal-to-noise ratio of the pulse oximeter signal and dynamically adjusts the LED drive current until the signal-to-noise ratio is greater than the minimum threshold level. The minimum threshold indicates a minimum allowable value for the signal-to-noise ratio for which the pulse rate and the oxygen saturation can be accurately calculated.

If the signal-to-noise ratio falls between the maximum and minimum threshold levels, the oximeter system maintains the LED drive current at a stable value. The oximeter system maintains equilibrium until the signal-to-noise ratio of the pulse oximeter signal moves outside the range of the thresholds. Thus, an oximeter system of the present invention contains a dynamic feedback loop as shown in FIG. 1. The dynamic feedback loop automatically adjusts the drive current of the LEDs to reduce power consumption in the sensor and to maintain the signal-to-noise ratio at an acceptable level for the purpose of accurately calculating blood oxygen saturation levels.

According to a preferred embodiment of the present invention, the hardware for the servo in pulse detection block **102** maintains a predictable relationship between the power that LED drive **104** attempts to drive the LEDs at and the radiated output power actually generated by the LEDs. By providing a predictable relationship between the input and output power, the feedback loop is more likely to acquire the oxygen saturation from the pulse oximeter signal in significantly less time, requiring less executions of the servo.

As the gain of the pulse oximeter signal is increased, the signal component generally increases faster than the noise component (at least to a point below the highest gain settings). The effect that increasing the gain of the pulse oximeter signal has on the signal-to-noise ratio in a particular system should be understood. Certain combinations of gain may cause more noise to be present in the pulse oximeter signal. Therefore, the gain stages in the pulse detection block preferably take advantage of characteristics of the gain-to-noise variability.

For example, the signal from the photodetector that is sampled using an analog-to-digital converter is fed into a gain

block. The gain block includes several gain stages to achieve a known response. The noise is measured at each of the gain stages, and then stored for later use to calculate the signal-to-noise ratio.

Techniques for identifying the systolic portions of a pulse oximeter signal generated by an oximeter sensor are now discussed. The systole identification of the present invention uses a three step maximum and minimum derivative averaging scheme in order to detect cardiac systolic events.

FIG. 2 illustrates one method for identifying the systolic period of a pulse oximeter signal. In the first step 201, the moving average of the derivative of the pulse oximeter signal is found. In the second step 202, the moving average of the output of the first step 201 is found. In the third step 203, the moving average of the output of the second step 202 is found.

Next, the moving maximum and the moving minimum of the output of the third step is found at step 204. At step 205, systole transitions are detected by comparing this moving minimum and moving maximum to a scaled sum of the moving minimum and maximum. For example, the scaled sum of the moving minimum and maximum values can be a fractional sum of the minimum and maximum moving averages.

When the minimum output of step 204 becomes less than a fractional sum of the maximum and minimum moving averages, the system determines that the pulse oximeter signal is entering systole. When the minimum output of step 204 becomes more than a fractional sum of the maximum and minimum moving averages, the system determines that pulse oximeter signal is exiting systole.

The two predetermined fractional sums can be selected to be any suitable values. As a specific example, the system can determine that the pulse oximeter signal is entering systole when the minimum derivative output becomes less than  $\frac{1}{6}$  the sum of the minimum and maximum moving averages of the third stage. As another example, the system can determine that the pulse oximeter signal is exiting systole when the minimum derivative output becomes more than  $\frac{1}{8}$  the sum of the maximum and minimum moving averages of the third stage. These two examples are not intended to limit the scope of the present invention. Many other fractional values can also be used to identify systole transitions.

These techniques of the present invention can detect and qualify pulses using CPU, RAM, and ROM efficient algorithms. Minimal processor resources are required to perform oximetry calculations with a comparable level of saturation and pulse rate performance as prior art oximeter technology.

Example waveforms for the results of these calculations are shown in FIG. 3A. Waveform 303 is an example of the derivative of a pulse oximeter signal. Waveforms 301 and 304 are examples of the minimum and maximum moving average of the pulse oximeter signal, respectively. Waveform 302 is an example of the output signal of the three-step moving average.

The output of the moving average is a smoothed and delayed version of the derivative of the pulse oximeter signal. The minimum output tracks the negative-going trends and lags the positive-going trends. The maximum output tracks the positive-going trends and lags the negative-going trends. These relationships are key to detecting potential systolic cardiac periods.

FIG. 3B shows examples of the minimum moving average 301 with a waveform 313 that represents  $\frac{1}{6}$  of the sum of the minimum and maximum moving averages of the third stage. FIG. 3B also shows an example of waveform 312 that represents  $\frac{1}{8}$  of the sum of the minimum and maximum moving averages of the third stage.

According to one embodiment of the present invention, waveforms 312 and 313 are compared to the minimum moving average waveform 301 at step 205 to identify the systolic period of the pulse oximeter signal. Alternatively, other scaled sums for the minimum and/or maximum moving averages can be used to identify systolic periods in the pulse oximeter signal. The beginning and the end of a systole in signal 301 are identified in FIG. 3B. The period between crossing points of signal 301 and signals 312/313 defines the systolic period.

When applied to the original pulse oximeter signal 320, the systolic period identification is shown in FIG. 3C. The systolic period includes the time between the peak (i.e. maximum value) and the subsequent valley (i.e. minimum value) of pulse oximeter signal 320. The actual systolic period is identified in FIG. 3C as well as the dichrotic notch of the next pulse.

After the systolic period has been identified, unique pulse qualification tests based upon typical physiological pulse characteristics are applied to the systole pulse at step 206. The full pulse qualification tests remove false positive systolic detections (e.g., the dichrotic notch) and pulses that have an inadequate signal-to-noise ratio. False positives are portions of the signal that are falsely identified as systolic transitions in step 205. Pulse qualifications are used in step 206 to filter out false positives identified in step 205. The steps of FIG. 2 can be implemented in software or hardware.

Pulse qualification tests qualify cardiac pulses in the pulse oximeter signal. The pulse qualification tests are designed to identify cardiac pulses that have adequate signal-to-noise ratio for use in measuring pulse rate and blood oxygen saturation. The pulse qualification tests can include any number techniques including traditional pulse qualification techniques.

Some examples of pulse qualification tests according to particular embodiments of the present invention are now discussed. The qualifications are comparisons of special pulse characteristics to determined threshold values. For example, the pulse qualifications compare systolic area, width, and number of sub-peaks to fixed thresholds. Diastolic area, width, and number of sub-peaks are compared to thresholds. Systolic area and width are compared to diastolic area and width. Pulse area and width are compared to thresholds. All of the above individually are compared to the last N pulses detected.

Pulses that pass these qualifications can be used to measure pulse rate. To qualify the systolic periods for oxygen saturation calculations, the following additional qualifications are used. The lag/lead time between the infrared and red pulse detection are compared. The pulse size is compared to the N pulses qualified. The statistically significant coefficient of the best-fit line plot of the moving average between the infrared and the red signals is compared to fixed thresholds. The saturation rate-of-change is compared to fixed thresholds. Pulses that pass these additional qualifications can be used to measure oxygen saturation.

After the pulse qualification tests have filtered out false positives, the systolic periods are identified. The systolic periods represent a signal component of the pulse oximeter signal. The signal-to-noise ratio of the pulse oximeter signal is calculated by comparing the strength of the systolic period to the noise component of the pulse oximeter signal.

According to one embodiment, the noise component of a pulse oximeter sensor is calculated in advance using a separate instrument that measures noise in the pulse oximeter signal at various gain values. The measured noise component is then stored in memory for later use. The stored noise

component is subsequently compared to the size of the systolic pulse for a particular gain value to determine the signal-to-noise ratio of the pulse oximeter signal.

According to another embodiment, dynamic measurements of the noise of the pulse oximeter system are made. These noise measurements can include electrical noise, ambient noise caused by ambient light, and/or noise (e.g. motion) caused by the patient. The dynamic noise measurement is updated continuously throughout the operation of the pulse oximeter sensor. An updated noise component is continuously compared to the pulse to calculate a more accurate signal-to-noise ratio of the pulse oximeter signal.

Once the signal-to-noise ratio of the pulse oximeter signal has been calculated, a determination is made as whether the signal-to-noise ratio falls within an acceptable range. The acceptable range is selected based on the relative noise component for accurately calculating oxygen saturation and pulse rate. If the ratio is outside the acceptable range, the feedback loop discussed above with respect to FIG. 1 adjusts the LED drive current to bring the signal-to-noise ratio within the acceptable range.

The present invention has the advantage of requiring fewer servo executions to acquire and maintain the oxygen saturation of the signal than many prior art techniques, particularly in the presence of patient motion interference. In many prior art oximeter systems, the LEDs are driven with a large current, and the pulse oximeter signal fills up its entire system dynamic range. The oximeter signal exceeds the system's current dynamic range as soon as the patient starts moving, and the signal is effectively lost (i.e., flat-line, invalid signal). Additional servo executions are required to re-acquire the signal. While the servo is executing, the sensor signal is not available; therefore, the oximeter cannot calculate pulse rate or oxygen saturation data from the pulse oximeter signal.

On the other hand, the LED drive current is substantially reduced in the present invention. The dynamic range is greatly increased relative to the size of the pulse oximeter signal, because the signal has been greatly reduced by cutting back on the LED drive current. The oximeter signal can now move around more within the dynamic range without requiring additional servo executions or changes to the LED settings. In the present invention, the patient can move around vigorously without causing the servo to execute in an attempt to re-acquire the signal. The techniques of the present invention can allow an oximeter system to be much more tolerant of patient motion.

Pulse detection block 102 can include a transimpedance (I-V) amplifier or converter 401 that converts a current signal from photodetector 112 to a voltage signal as shown in FIG. 4. Ambient light in the environment adds a component of DC bias into the pulse oximeter signal. This DC bias shifts the pulse oximeter signal higher, closer to the rail of the dynamic range of the transimpedance amplifier.

According to an embodiment of the present invention, an analog-to-digital (A-to-D) converter 402 samples the output signal of transimpedance amplifier 401 during a time when either LED 110-111 is on or off to provide a continuous, real-time measurement of the ambient light and or noise that gets into sensor 101. This feature can also be used to provide information on the magnitude of the signal at the output of A-to-D converter 402.

The information about the signal magnitude from A-to-D converter 402 is fed back through gain control feedback loop 403 and used to choose an appropriate gain for transimpedance amplifier 401. For example, gain control feedback loop 403 causes the transimpedance gain of transimpedance amplifier 401 to increase or decrease to reduce and/or accom-

modate the effect of the environmental DC bias on the signal. This real-time measurement can also be used for determining a sensor-off condition, measuring electrical and optical noise, detecting transients in the signal, and detecting patient motion.

During the normal operation of the sensor, the LEDs can be pulsed on and off in any desired manner to provide the continuous (multiplexed), real-time measurement of the ambient light and other noise sources. For example, one red and one infrared LED can be alternately turned on and off in the following manner: red LED on and infrared LED off, then red LED off and infrared LED on, then both LEDs off, then red LED on and infrared LED off, etc. repeating in this sequence. As another example, one red and one infrared LED can be alternately turned on and off as follows: red LED on and infrared LED off, then both LEDs off, then red LED off and infrared LED on, then both LEDs off, then red LED on and infrared LED off, etc. repeating in this sequence. These patterns are examples that are not intended to limit the scope of the present invention.

Sigma-delta modulator 410 also receives the output signal of the transimpedance amplifier 402. Modulator 410 demodulates the signal from the photodetector into separate red and infrared components. The demodulation function can be performed in the digital domain using a software or firmware program run by a microcontroller. Further details of a Multi-Bit ADC With Sigma-Delta Modulation are discussed in commonly assigned, co-pending U.S. Patent Application 2005/0184895, to Ethan Petersen et al., filed concurrently herewith, which is incorporated by reference herein.

As will be understood by those of skill in the art, the present invention could be embodied in other specific forms without departing from the essential characteristic thereof. Accordingly, the foregoing description is intended to be illustrative, but not limiting, on the scope of the invention which is set forth in the following claims.

For example, the components in pulse detection block 102 that are shown in FIG. 4 can be implemented in systems other than pulse oximeter systems. These components can reduce the effect of noise in signals from other types of sensors as well.

What is claimed is:

1. A pulse oximeter system comprising:

a drive interface that controls drive current of light emitting elements in a pulse oximeter sensor; and

a feedback loop coupled around the pulse oximeter sensor and the drive interface that is capable of dynamically adjusting the drive current of the light emitting elements based at least in part upon results of a comparison between a signal-to-noise ratio of a pulse oximeter signal and a threshold, wherein the feedback loop is capable of detecting systolic transitions based at least in part upon a multi-step averaging scheme,

wherein the pulse oximeter signal is generated by a photodetector in the pulse oximeter sensor.

2. The pulse oximeter system as defined in claim 1 wherein the feedback loop causes the drive current of the light emitting elements to decrease if the signal-to-noise ratio of the pulse oximeter signal is greater than a maximum threshold, and the feedback loop causes the drive current of the light emitting elements to increase if the signal-to-noise ratio of the pulse oximeter signal is less than a minimum threshold.

3. The pulse oximeter system as defined in claim 1 wherein the feedback loop further comprises:

a pulse detection block that is capable of calculating the signal-to-noise ratio of the pulse oximeter signal; and

a comparator that is capable of performing the comparison of the signal-to-noise ratio of the pulse oximeter signal to the threshold.

4. A method for reducing power consumption in a pulse oximeter sensor, the method comprising:

- providing drive current to light emitting elements in the pulse oximeter sensor; and
- dynamically determining a signal-to-noise ratio of a pulse oximeter signal generated by a photodetector in the pulse oximeter sensor, wherein determining the signal-to-noise ratio comprises measuring and storing the noise at each of a plurality of gain stages; and
- dynamically adjusting the drive current of the light emitting elements based at least in part upon results of a comparison between the signal-to-noise ratio of the pulse oximeter signal and a threshold.

5. The method as defined in claim 4 wherein dynamically adjusting the drive current of the light emitting elements further comprises:

- increasing the drive current provided to the light emitting elements if the signal-to-noise ratio of the pulse oximeter signal is less than a minimum threshold; and
- decreasing the drive current provided to the light emitting elements if the signal-to-noise ratio of the pulse oximeter signal is greater than a maximum threshold.

6. A system coupled to a sensor, the system comprising:

- a transimpedance amplifier capable of receiving a current signal from the sensor and converting the current signal to a voltage signal based at least in part upon a transimpedance gain;
- an analog-to-digital converter capable of converting the voltage signal into a digital signal; and
- a feedback loop capable of providing a feedback signal indicating a magnitude of the voltage signal from the transimpedance amplifier when light emitting elements in the sensor are on or off,

wherein the transimpedance gain is capable of being adjusted in response to the feedback signal to reduce the environmental DC bias on the voltage signal.

7. The system as defined in claim 6 wherein the sensor is a pulse oximeter sensor containing a photodetector.

8. The system as defined in claim 6 further comprising:

- a pulse detector that is capable of calculating the signal-to-noise ratio of the signal from the sensor;
- a comparator that is capable of comparing the signal-to-noise ratio to a threshold; and
- a drive interface that is capable of controlling drive current of the light emitting elements.

9. A method for controlling drive current of light emitting elements in a pulse oximeter sensor, comprising:

- using a pulse oximeter:
  - measuring a noise component of a pulse oximeter signal;
  - identifying a systolic period of the pulse oximeter signal;
  - performing first pulse qualification tests to qualify a systolic period for pulse rate measurement;
  - performing second pulse qualification tests to qualify the systolic period for oxygen saturation calculations, if the systolic period is qualified for pulse rate measurement;
  - determining a strength of the systolic period if the systolic period is qualified for oxygen saturation calculations;
  - identifying a signal-to-noise ratio by comparing the strength of the systolic period to the noise component; and
- controlling the drive current based at least in part upon a comparison of the signal-to-noise ratio to a threshold.

10. The method of claim 9, comprising measuring the noise component before determining the strength of the systolic

period and storing the measured noise component in memory for comparison with the strength of the systolic period.

11. The method of claim 9, comprising measuring the noise in the pulse oximeter signal at various gain values.

12. The method of claim 9, wherein the threshold comprises a maximum signal-to-noise ratio value of 128:1.

13. The method of claim 9, wherein the threshold comprises a minimum signal-to-noise ratio value of 8:1.

14. The method of claim 9, comprising calculating a series of moving averages based at least in part upon a derivative of the pulse oximeter signal to identify the systolic period.

15. The method of claim 14, comprising identifying a moving minimum and moving maximum of a last moving average of the series of moving averages to identify the systolic period.

16. The method of claim 9, comprising calculating a moving average of a derivative of the pulse oximeter signal to generate a first output, calculating a moving average of the first output to generate a second output, calculating a moving average of the second output to generate a third output, and identifying a moving minimum and a moving maximum of the third output to identify the systolic period.

17. The method of claim 16, comprising comparing the moving minimum and the moving maximum to a scaled sum of the moving minimum and the moving maximum to determine the systolic period.

18. A monitor for controlling drive current of light emitting elements in a pulse oximeter sensor, comprising:

- an identification module capable of identifying a systolic period of a pulse oximeter signal;
- a qualification module capable of performing multiple stages of pulse qualification tests to qualify the systolic period for oxygen saturation calculations;
- a strength determination module capable of determining a strength of the systolic period if the systolic period is qualified for oxygen saturation calculations;
- a ratio module capable of identifying a signal-to-noise ratio by comparing the strength of the systolic period to a measured value of a noise component of the pulse oximeter signal stored in a memory; and
- a controller capable of controlling the drive current based at least in part upon a comparison of the signal-to-noise ratio to a threshold.

19. The monitor of claim 18, comprising a measurement module capable of measuring the noise component.

20. The monitor of claim 19, wherein the measurement module is capable of measuring the noise component at various gain values.

21. The monitor of claim 18, wherein the threshold comprises a maximum signal-to-noise ratio value of 128:1.

22. The monitor of claim 18, wherein the threshold comprises a minimum signal-to-noise ratio value of 8:1.

23. The monitor of claim 18, comprising a calculation module capable of calculating a series of moving averages based at least in part upon a derivative of the pulse oximeter signal to identify the systolic period.

24. The monitor of claim 23, wherein the calculation module is capable of identifying a moving minimum and moving maximum of a last moving average of the series of moving averages to identify the systolic period.

25. The monitor of claim 18, comprising a calculation module capable of calculating a moving average of a derivative of the pulse oximeter signal to generate a first output, calculating a moving average of the first output to generate a second output, calculating a moving average of the second

11

output to generate a third output, and identifying a moving minimum and a moving maximum of the third output to identify the systolic period.

26. The monitor of claim 25, comprising a comparison module capable of comparing the moving minimum and the moving maximum to a scaled sum of the moving minimum and the moving maximum to determine the systolic period.

27. A tangible computer-readable medium, comprising:

code capable of identifying a systolic period of a pulse oximeter signal, wherein identifying a systolic period comprises calculating a moving average;

code capable of performing pulse qualification tests to qualify the systolic period for oxygen saturation calculations;

code capable of determining a strength of the systolic period if the systolic period is qualified for oxygen saturation calculations;

12

code capable of identifying a signal-to-noise ratio by comparing the strength of the systolic period to a measured value of a noise component of the pulse oximeter signal; and

code capable of controlling the drive current based at least in part upon a comparison of the signal-to-noise ratio to a threshold.

28. The tangible computer-readable medium of claim 27, comprising code capable of measuring the noise component of the pulse oximeter signal.

29. The tangible computer-readable medium of claim 27, comprising code capable of calculating a moving average of a derivative of the pulse oximeter signal to generate a first output, calculating a moving average of the first output to generate a second output, calculating a moving average of the second output to generate a third output, and identifying a moving minimum and a moving maximum of the third output to identify the systolic period.

\* \* \* \* \*

专利名称(译)	用于检测心脏脉冲并降低传感器中的功耗的技术		
公开(公告)号	<a href="#">US7499740</a>	公开(公告)日	2009-03-03
申请号	US11/650861	申请日	2007-01-08
[标]申请(专利权)人(译)	内尔科尔普里坦贝内特公司		
申请(专利权)人(译)	NELLCOR PURITAN BENNETT INC.		
当前申请(专利权)人(译)	NELLCOR PURITAN BENNETT LLC		
[标]发明人	NORDSTROM BRAD SHEA WILLIAM PETERSEN ETHAN		
发明人	NORDSTROM, BRAD SHEA, WILLIAM PETERSEN, ETHAN		
IPC分类号	A61B5/1455 A61B5/00 A61B5/024		
CPC分类号	A61B5/14551 A61B5/7207 A61B5/02416 A61B2560/0209 A61B5/7239		
其他公开文献	US20070208240A1		
外部链接	<a href="#">Espacenet</a> <a href="#">USPTO</a>		

摘要(译)

提供了用于感测来自传感器的信号中的心脏脉冲的低功率技术。脉冲检测模块检测传感器信号并确定其信噪比。在将信噪比与阈值进行比较之后，动态调整传感器中的发光元件的驱动电流以降低功耗，同时将信噪比保持在适当的水平。可以通过识别收缩期转变来测量传感器信号的信号分量。使用最大和最小导数平均方案检测收缩期转变。将移动最小值和移动最大值与移动最小值和移动最大值的缩放总和进行比较，以识别收缩过渡。一旦识别出信号分量，就将信号分量与噪声分量进行比较，以计算信噪比。

