



(19) **United States**

(12) **Patent Application Publication**  
**Debreczeny et al.**

(10) **Pub. No.: US 2008/0009690 A1**  
(43) **Pub. Date: Jan. 10, 2008**

(54) **PULSE OXIMETRY MOTION ARTIFACT REJECTION USING NEAR INFRARED ABSORPTION BY WATER**

**Publication Classification**

(51) **Int. Cl.**  
*A61B 5/02* (2006.01)  
(52) **U.S. Cl.** ..... **600/336**

(75) **Inventors: Martin Debreczeny, Danville, CA (US); Clark R. Baker JR., Newman, CA (US)**

(57) **ABSTRACT**

A method and an apparatus for measuring a physiological parameter, functioning based on obtaining a first signal derived from electromagnetic energy transmitted through a tissue portion at a first wavelength, the first signal including a signal portion corresponding with motion-related events and a signal portion corresponding with arterial pulsation events, where at the first wavelength water is a dominant absorber of electromagnetic energy in the tissue portion; obtaining a second signal derived from electromagnetic energy transmitted through a tissue portion at a second wavelength, the second signal including a signal portion corresponding with motion-related events and a signal portion corresponding with arterial pulsation events, where at the second wavelength hemoglobin is a dominant absorber of electromagnetic energy in the tissue portion; and combining the first signal and the second signal to generate a combined plethysmograph signal, such that the combined signal has a signal portion corresponding with motion-related events that is smaller than that present in the first signal or the second signal.

Correspondence Address:  
**Nellcor Puritan Bennett LLC**  
**c/o Fletcher Yoder PC**  
**P.O. BOX 692289**  
**HOUSTON, TX 77269-2289 (US)**

(73) **Assignee: Nellcor Puritan Bennett LLC, Pleasanton, CA (US)**

(21) **Appl. No.: 11/901,643**  
(22) **Filed: Sep. 18, 2007**

**Related U.S. Application Data**

(63) **Continuation of application No. 10/797,475, filed on Mar. 9, 2004, now Pat. No. 7,277,741.**

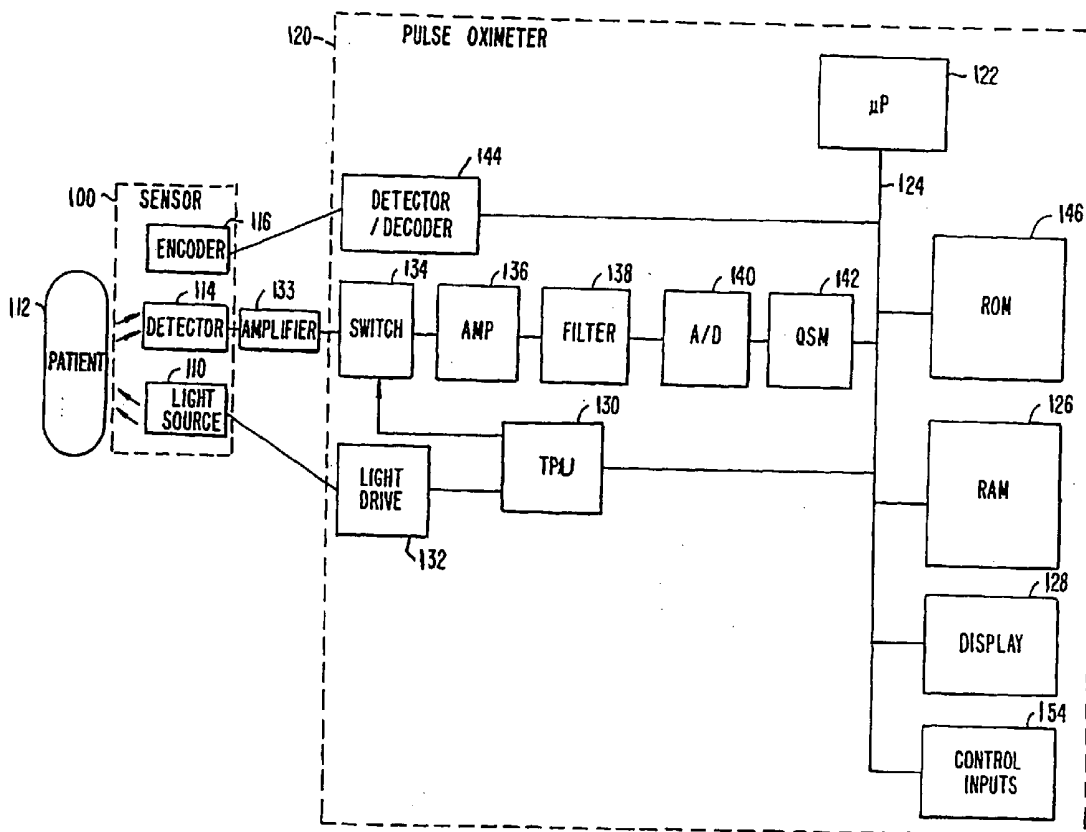

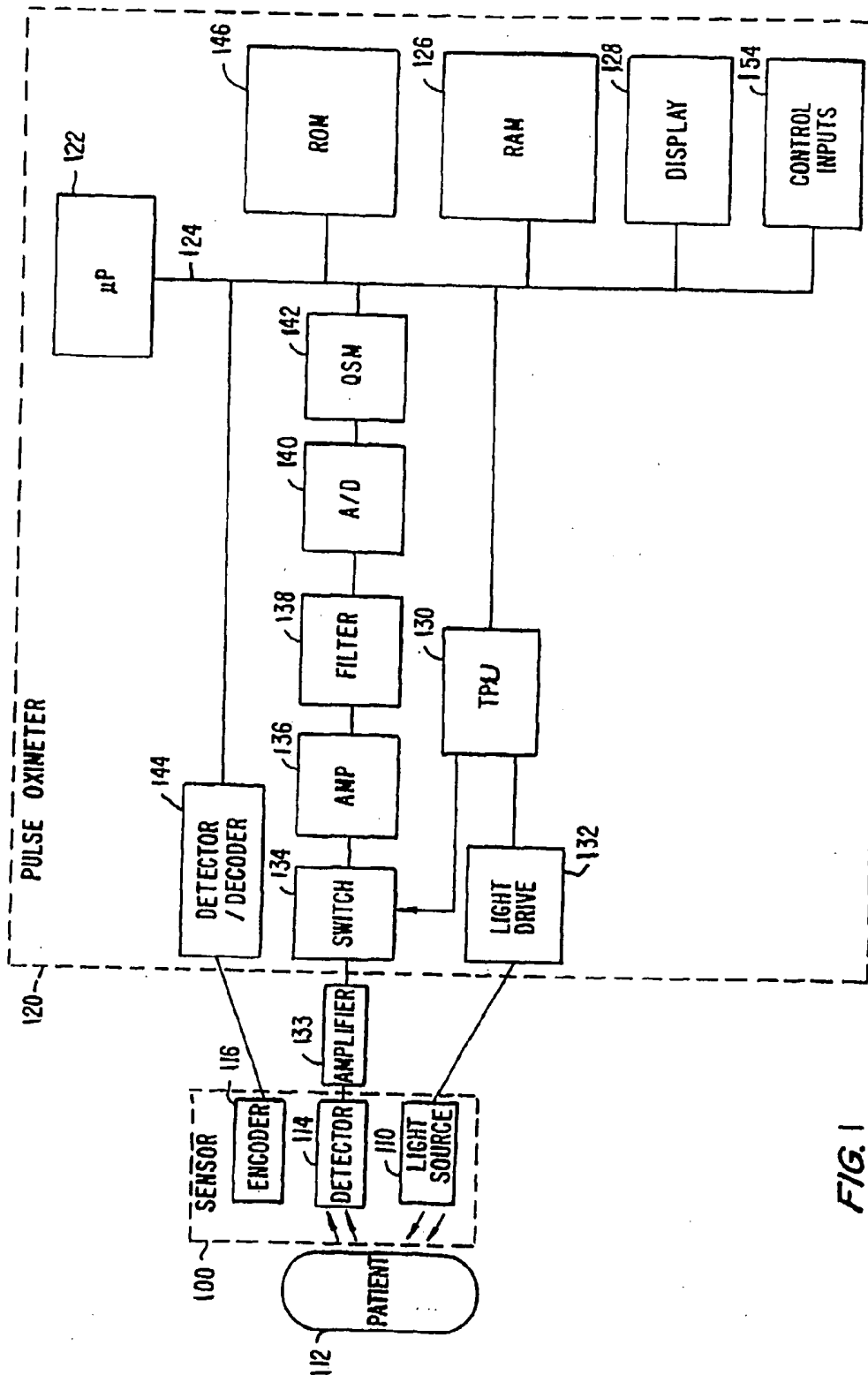

FIG. 1

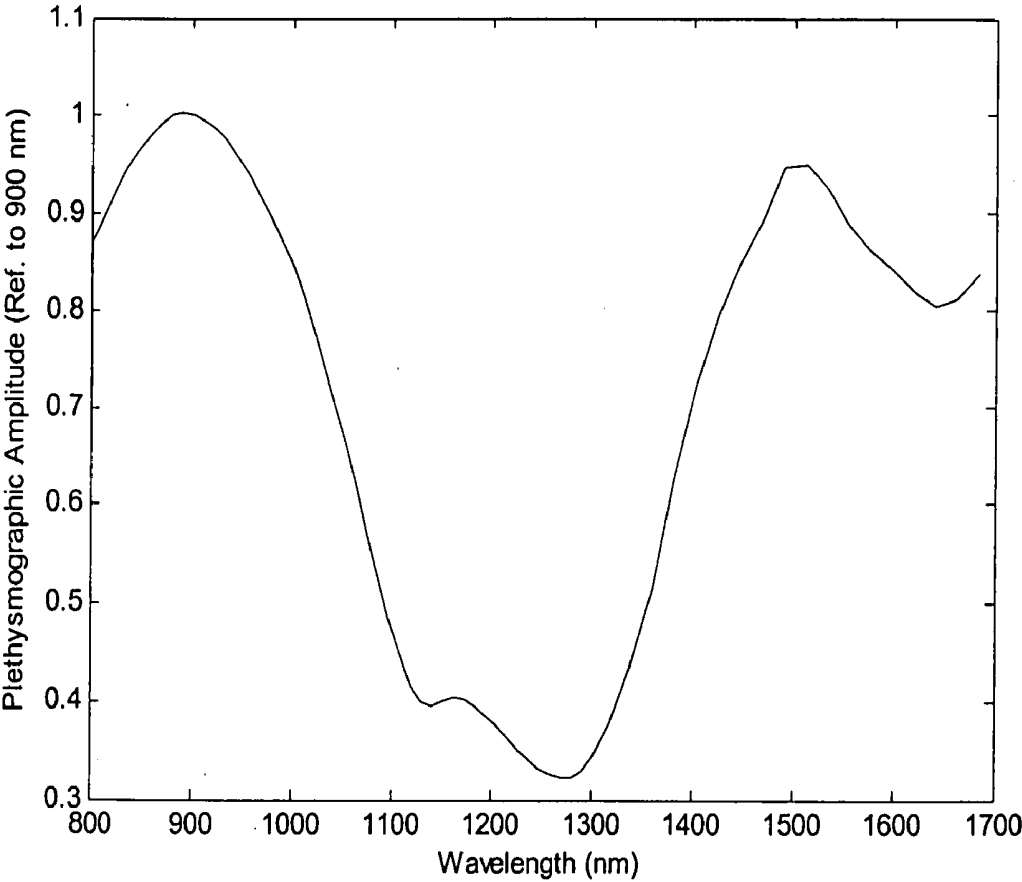

Fig. 2

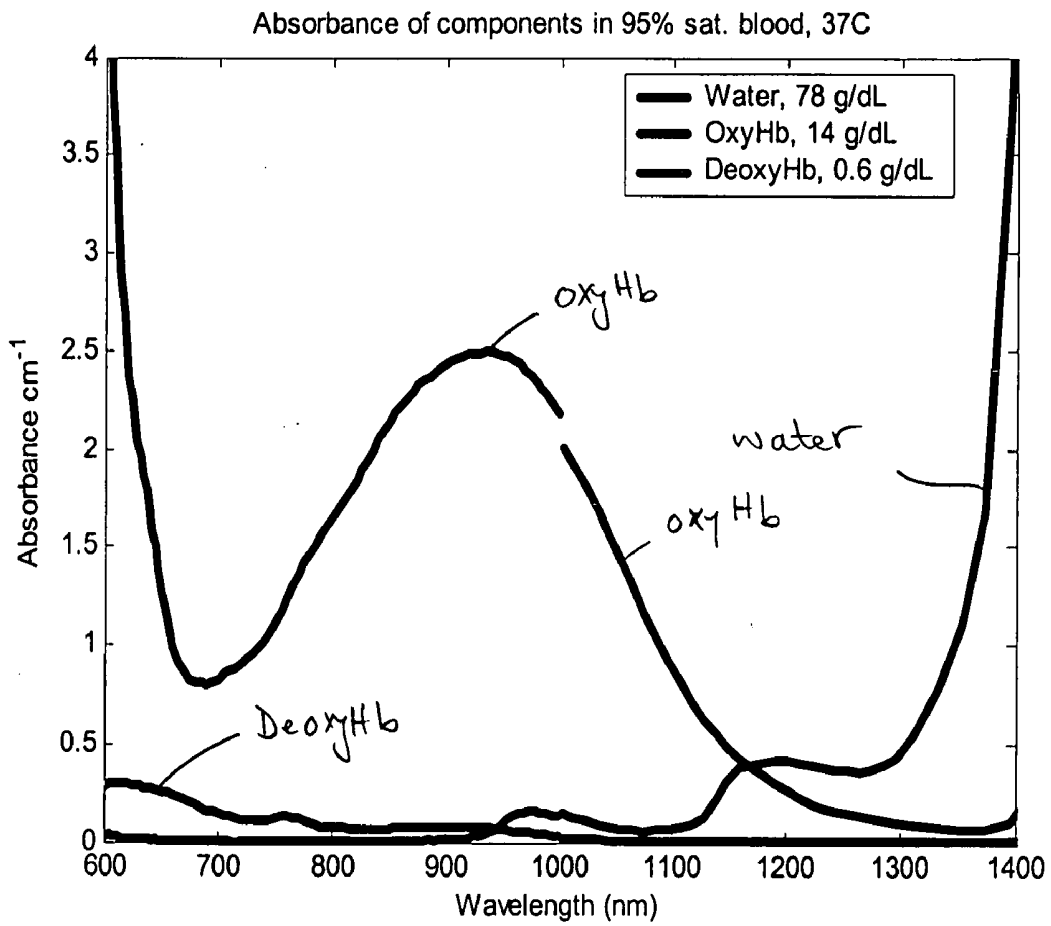

Fig. 3

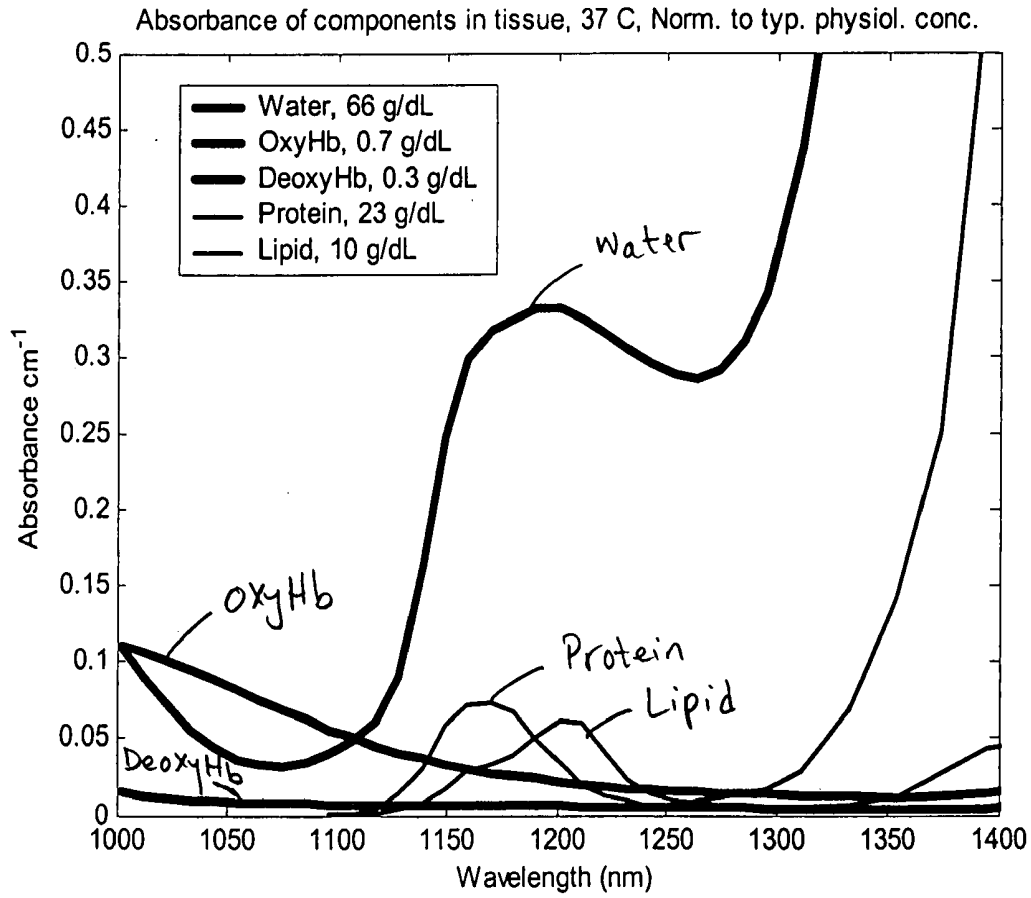

Fig. 4

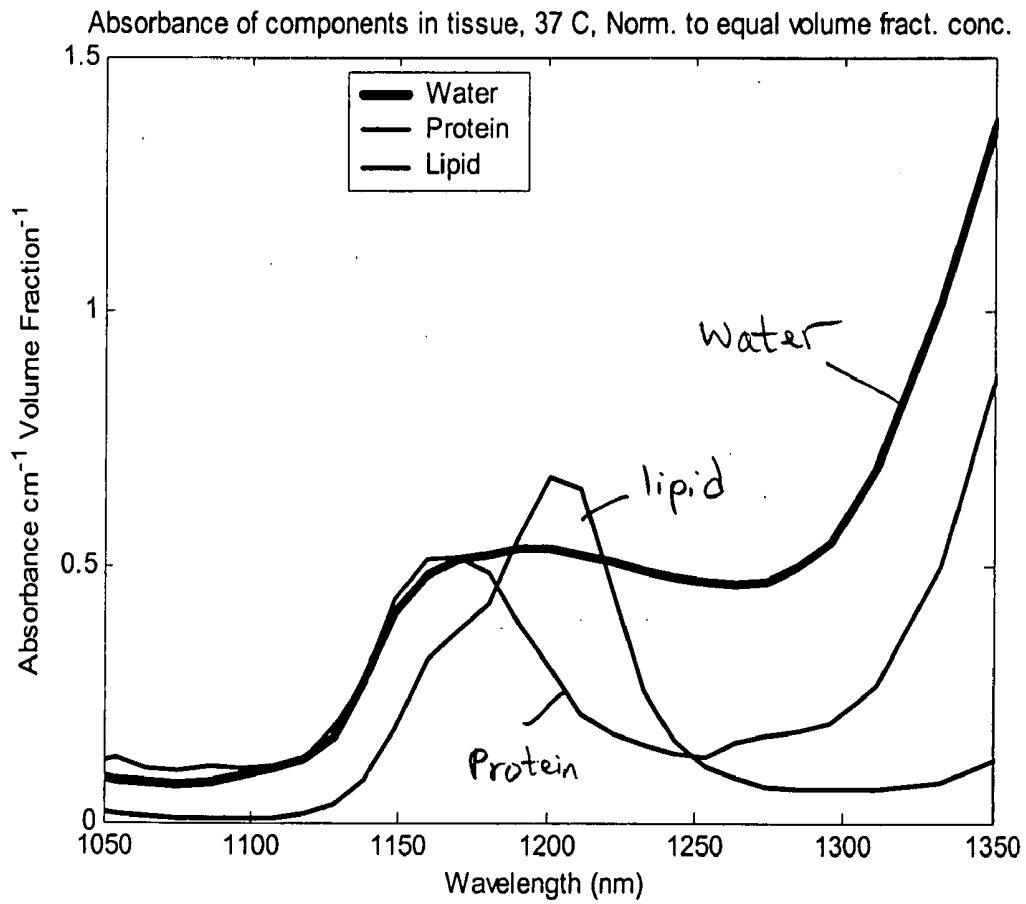

Fig. 5

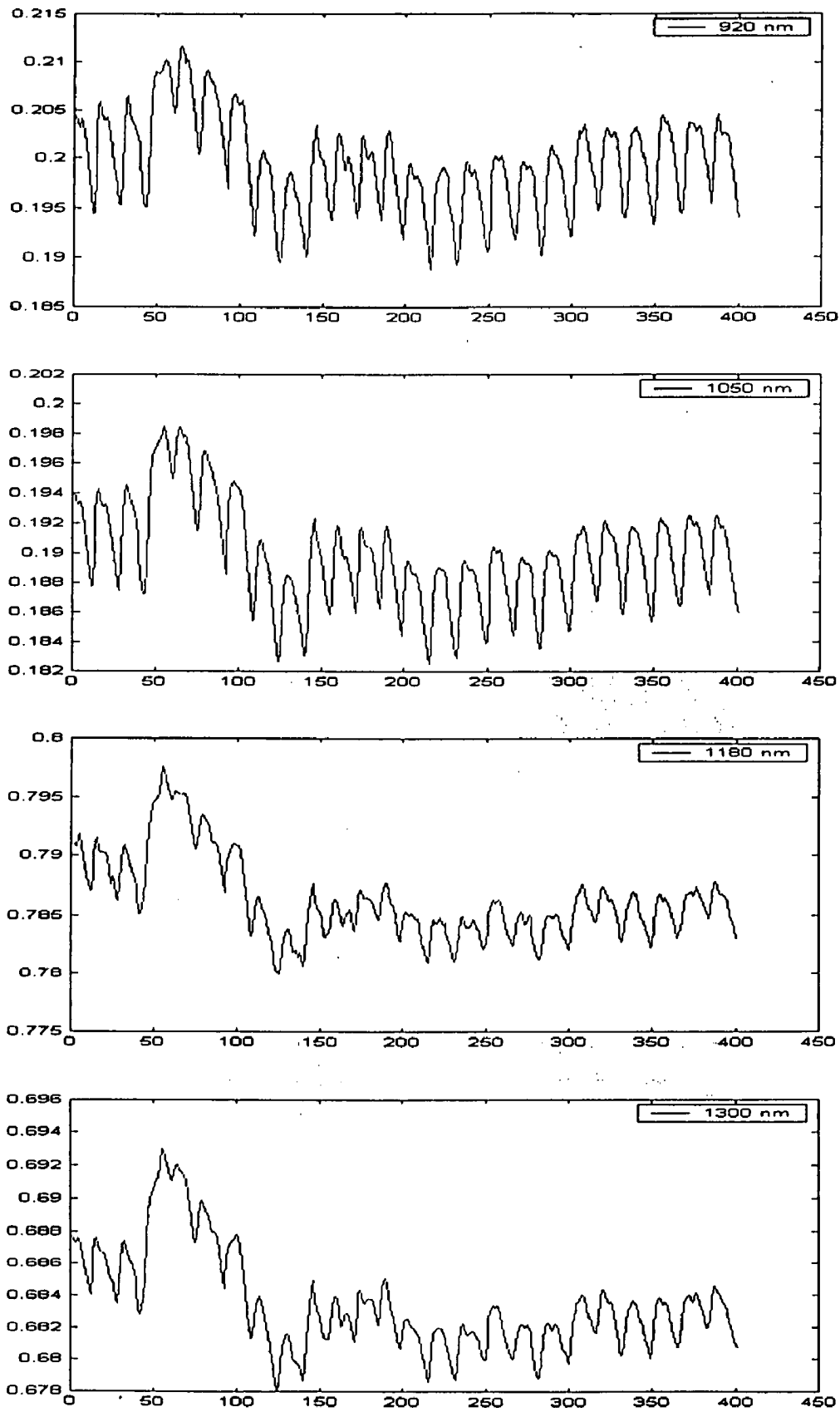

Fig. 6

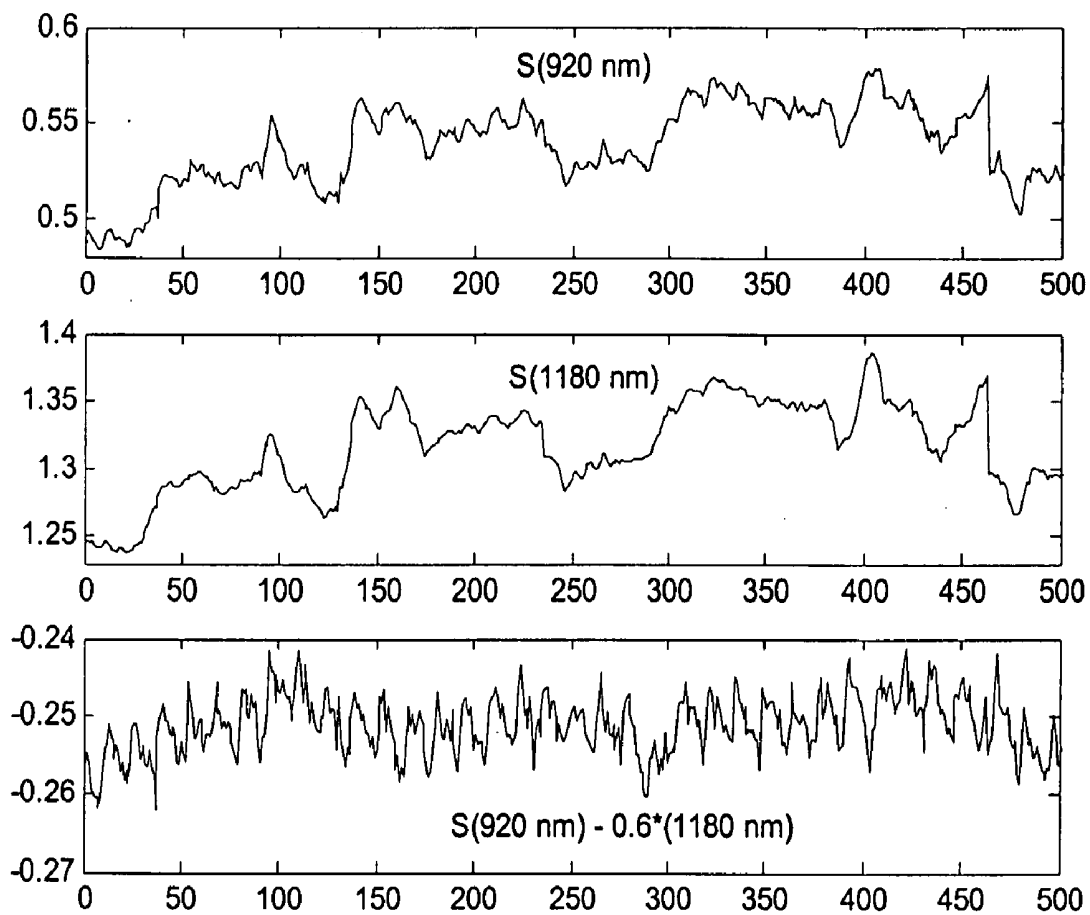

Fig. 7

**PULSE OXIMETRY MOTION ARTIFACT  
REJECTION USING NEAR INFRARED  
ABSORPTION BY WATER**

**BACKGROUND OF THE INVENTION**

[0001] The present invention relates to the processing of signals obtained from a medical diagnostic apparatus, such as a pulse oximeter, using near infrared spectroscopy, to remove artifact or noise effects from the signal representative of a physiological parameter of interest.

[0002] A typical pulse oximeter measures two physiological parameters, percent oxygen saturation of arterial blood hemoglobin (SpO<sub>2</sub> or sat) and pulse rate. Oxygen saturation can be estimated using various techniques. In one common technique, the photocurrent generated by the photo-detector is conditioned and processed to determine the ratio of modulation ratios (ratio of ratios) of the red to infrared signals. This modulation ratio has been observed to correlate well to arterial oxygen saturation. The pulse oximeters and sensors are empirically calibrated by measuring the modulation ratio over a range of in vivo measured arterial oxygen saturations (SaO<sub>2</sub>) on a set of patients, healthy volunteers, or animals. The observed correlation is used in an inverse manner to estimate blood oxygen saturation (SpO<sub>2</sub>) based on the measured value of modulation ratios of a patient. Most pulse oximeters extract the plethysmographic signal having first determined saturation or pulse rate, both of which are susceptible to interference.

[0003] In general, pulse oximetry takes advantage of the fact that in live human tissue, hemoglobin is a strong absorber of light between the wavelengths of 500 and 1100 nm. The pulsation of arterial blood through tissue is readily measurable, using light absorption by hemoglobin in this wavelength range. A graph of the arterial pulsation waveform as a function of time is referred to as an optical plethysmograph. The amplitude of the plethysmographic waveform varies as a function of the wavelength of the light used to measure it, as determined by the absorption properties of the blood pulsing through the arteries. By combining plethysmographic measurements at two different wavelength regions, where oxy- and deoxy-hemoglobin have different absorption coefficients, the oxygen saturation of arterial blood can be estimated. Typical wavelengths employed in commercial pulse oximeters are 660 and 890 nm.

[0004] It is known that rapid motion or application of pressure to a tissue site can have the effect of changing the optical properties being measured at or near that site. The amplitude of the optical signal changes associated with such events, known as motion artifacts, can easily be larger than that due to the arterial pulse. In practice, this can lead to inaccurate estimation of the percent oxygen saturation by pulse oximetry. Various techniques for addressing and removing undesired signal effects, including motion artifacts are known. As used herein, noise refers to signal portions that are undesired or are not directly related to changes in optical properties that are related to the arterial pulse, and which may include motion artifact. The optical signal through the tissue can be degraded by both noise and motion artifact. One source of noise is ambient light which reaches the light detector. Another source of noise is electromagnetic coupling from other electronic instruments. Motion of the

patient also introduces noise and affects the signal. For example, the contact between the detector and the skin, or the emitter and the skin, can be temporarily disrupted when motion causes either to move away from the skin. In addition, since blood is a fluid, it responds differently than the surrounding tissue to inertial effects, thus resulting in momentary changes in volume at the point near which the oximeter probe is attached.

[0005] Motion artifact can degrade a pulse oximetry signal relied upon by a health care provider, without the provider's awareness. This is especially true if the monitoring of the patient is remote, the motion is too small to be observed, or the health care provider is watching the instrument or other parts of the patient, and not the sensor site. There are various known techniques for addressing the effects of noise and/or motion artifacts.

[0006] For example, U.S. Pat. No. 4,714,341 discloses a method for combining three wavelengths to detect the presence of motion. The wavelengths are used two at a time to separately compute the oxygen saturation percentage. When the oxygen saturation values computed using different wavelength combinations are in poor agreement, this is assumed to be caused by motion artifact, and the value is discarded. A disadvantage of this approach is that the agreement or lack thereof between the saturation values may or may not be due to motion artifact. In addition, this approach does not identify or remove the effects of motion artifact, but instead discards values that appear suspect.

[0007] Another approach involves the filtering of pulse oximetry signals. However, filtering methods require assumptions about the properties of the artifact that do not always hold in practice. In addition, this approach does not measure the motion-induced signal.

[0008] U.S. Pat. No. 5,482,036 provides another approach, and describes a signal processing method for artifact reduction that functions when the artifact-related signal is associated with blood that is at a lower oxygen saturation than the arterial blood. Such a method relies on the generation of an artificial noise signal, which is combined with the physiological parameter to reduce the effect of the unknown noise signal. This approach for reducing the effects of artifact, without separately measuring the motion signal, is based on assumptions about the effect of motion on the plethysmographic signal. Assumptions may or may not be true, and many assumptions are invalid.

[0009] Each of the known techniques for compensating for motion artifact has its own limitations and drawbacks. It is therefore desirable that a pulse oximetry system be designed which more effectively and accurately reports blood-oxygen levels during periods of motion. While many have attempted to isolate the effects of undesired signal portions, such as motion-induced artifacts, by making potentially invalid assumptions or by rejecting suspect estimates of desired signal values, there still remains a need for a deterministic identification, determination and measurement of artifact signals, to enable an accurate measurement of the desired signal values in the presence of undesired signal portions.

## BRIEF SUMMARY OF THE INVENTION

[0010] By measuring the artifact signal, the present invention allows motion artifact to be separated from the plethysmographic signal without the limiting assumptions of prior known techniques. The present invention provides methods for measuring the motion signal associated with changes in tissue optical properties and using the measurement to compensate plethysmographic measurements made at other wavelengths.

[0011] In one embodiment, the present invention provides a method of measuring a physiological parameter, including obtaining a first signal derived from electromagnetic energy transmitted through a tissue portion at a first wavelength, the first signal including a signal portion corresponding with motion-related events and a signal portion corresponding with arterial pulsation events, where at the first wavelength water is a dominant absorber of electromagnetic energy in the tissue portion; obtaining a second signal derived from electromagnetic energy transmitted through a tissue portion at a second wavelength, the second signal including a signal portion corresponding with motion-related events and a signal portion corresponding with arterial pulsation events, where at the second wavelength hemoglobin is a dominant absorber of electromagnetic energy in the tissue portion; and combining the first signal and the second signal to generate a combined plethysmograph signal, such that the combined signal has a signal portion corresponding with motion-related events that is smaller than that present in the first signal or the second signal.

[0012] At the first wavelength water is a stronger absorber of electromagnetic energy than hemoglobin in the tissue portion, and at the second wavelength hemoglobin is a stronger absorber of electromagnetic energy than water in the tissue portion.

[0013] For a fuller understanding of the nature and advantages of the embodiments of the present invention, reference should be made to the following detailed description taken in conjunction with the accompanying drawings.

## BRIEF DESCRIPTION OF THE DRAWINGS

[0014] FIG. 1 is a block diagram of an exemplary oximeter.

[0015] FIG. 2 is a graph of the plethysmographic amplitude measured on the human ear as a function of wavelength.

[0016] FIG. 3 is a graph of absorption spectra of the principal components in human blood.

[0017] FIG. 4 is a graph of absorption spectra of the principal components in human skin, scaled to typical physiological concentration.

[0018] FIG. 5 is a graph of absorption spectra of the principal components in human skin, scaled to equal volume-fraction concentration.

[0019] FIG. 6 is a graph of plethysmographs measured on a human ear at 4 different wavelengths of approximately 920, 1050, 1180 and 1300 nm respectively.

[0020] FIG. 7 is a graph of an exemplary plethysmographic artifact reduction by combining measurements at 2 near infrared wavelengths.

## DETAILED DESCRIPTION OF THE INVENTION

[0021] By measuring the artifact signal, the present invention allows motion artifact to be separated from the plethysmographic signal without the limiting assumptions of prior known techniques. The present invention provides methods for measuring the motion signal associated with changes in tissue optical properties and using the measurement to compensate plethysmographic measurements made at other wavelengths.

[0022] FIG. 1 is a block diagram of an exemplary pulse oximeter that may be configured to implement the embodiments of the present invention. The embodiments of the present invention can be a data processing algorithm that is executed by the microprocessor 122, described below. Light from light source 110 passes into patient tissue 112, and is scattered and detected by photodetector 114. A sensor 100 containing the light source and photodetector may also contain an encoder 116 which provides signals indicative of the wavelength of light source 110 to allow the oximeter to select appropriate calibration coefficients for calculating oxygen saturation. Encoder 116 may, for instance, be a resistor.

[0023] Sensor 100 is connected to a pulse oximeter 120. The oximeter includes a microprocessor 122 connected to an internal bus 124. Also connected to the bus are a RAM memory 126 and a display 128. A time processing unit (TPU) 130 provides timing control signals to light drive circuitry 132 which controls when light source 110 is illuminated, and if multiple light sources are used, the multiplexed timing for the different light sources. TPU 130 also controls the gating-in of signals from photodetector 114 through an amplifier 133 and a switching circuit 134. These signals are sampled at the proper time, depending upon which of multiple light sources is illuminated, if multiple light sources are used. The received signal is passed through an amplifier 136, a low pass filter 138, and an analog-to-digital converter 140. The digital data is then stored in a queued serial module (QSM) 142, for later downloading to RAM 126 as QSM 142 fills up. In one embodiment, there may be multiple parallel paths of separate amplifiers, filters and A/D converters for multiple light wavelengths or spectra received.

[0024] Based on the value of the received signals corresponding to the light received by photodetector 114, microprocessor 122 will calculate the oxygen saturation using various algorithms. These algorithms require coefficients, which may be empirically determined, corresponding to, for example, the wavelengths of light used. These are stored in a ROM 146. In a two-wavelength system, the particular set of coefficients chosen for any pair of wavelength spectra is determined by the value indicated by encoder 116 corresponding to a particular light source in a particular sensor 100. In one embodiment, multiple resistor values may be assigned to select different sets of coefficients. In another embodiment, the same resistors are used to select from among the coefficients appropriate for an infrared source paired with either a near red source or far red source. The selection between whether the near red or far red set will be chosen can be selected with a control input from control inputs 154. Control inputs 154 may be, for instance, a switch on the pulse oximeter, a keyboard, or a port providing

instructions from a remote host computer. Furthermore, any number of methods or algorithms may be used to determine a patient's pulse rate, oxygen saturation or any other desired physiological parameter. For example, the estimation of oxygen saturation using modulation ratios is described in U.S. Pat. No. 5,853,364, entitled "METHOD AND APPARATUS FOR ESTIMATING PHYSIOLOGICAL PARAMETERS USING MODEL-BASED ADAPTIVE FILTERING," issued Dec. 29, 1998, and U.S. Pat. No. 4,911,167, entitled "METHOD AND APPARATUS FOR DETECTING OPTICAL PULSES," issued Mar. 27, 1990. Furthermore, the relationship between oxygen saturation and modulation ratio is further described in U.S. Pat. No. 5,645,059, entitled "MEDICAL SENSOR WITH MODULATED ENCODING SCHEME," issued Jul. 8, 1997.

[0025] Having described an exemplary pulse oximeter above, the methods for reducing noise, including motion artifact effects in the received signals, according to embodiments of the present invention, are described below.

[0026] FIG. 2 is a plot of the average plethysmographic amplitude as a function of wavelength measured through the earlobe of 36 subjects, and normalized to measurements at a wavelength of approximately 900 nm. Measurements, such as those shown in FIG. 2, reveal that the amplitude of the photoplethysmographic waveform diminishes as a function of wavelength between approximately 900 and 1300 nm, having a minimum value at approximately 1285 nm. The inventors herein have discovered that at wavelengths beyond approximately 900-920 nm, water, which is at much higher concentrations than hemoglobin, also becomes a major light absorber in tissue. FIG. 3 is a graph of some of the light absorbing components found in blood, in units of absorbance in  $\text{cm}^{-1}$  vs. wavelength in nm. FIG. 3 shows that at approximately 1400 nm, the absorbance of water is approximately 60% higher than that of oxy-hemoglobin, yet the plethysmographic amplitude (FIG. 2) at 1400 nm is 35% lower than that at approximately 900 nm.

[0027] FIG. 4 is a graph of absorption spectra ( $\text{cm}^{-1}$ ) of the principal components in human skin, scaled to typical physiological concentration, as a function of wavelength in nm. This figure shows that the absorbance due to water has a peak value at approximately 1180 nm, and that similar peaks are present for protein at slightly above 1150 and for lipids at approximately 1200 nm.

[0028] FIG. 5 is a graph of absorption spectra of the principal components in human skin, scaled to equal volume-fraction concentration. This figure shows that at approximately 1185 nm, the volume-fraction scaled absorbance for water, lipids and proteins are approximately equal.

[0029] While not being limited to any particular theory, the present inventors note that a reason for the weaker plethysmographic effect of water (at wavelengths below approximately 900 and below approximately 1300 nm) compared to hemoglobin lies in the fact that hemoglobin is largely confined to the blood vessels, whereas water is present at high concentrations both in the blood vessels and in the surrounding tissue. As a result, the pulse-induced expansion of arterial vessels through a tissue bed results in a localized increase in hemoglobin concentration, but only a small net change in water concentration. To the extent that the water concentration in the blood is equal to the water concentration in tissue, the change in light absorption by water is expected to approach zero.

[0030] The embodiments of the present invention exploit the finding that in spectral regions where hemoglobin absorbs weakly and water absorbs strongly, the plethysmograph is more sensitive to motion-related events than arterial pulsation, compared with spectral regions where hemoglobin is a strong absorber and water is a weak absorber.

[0031] The weak magnitude of the plethysmograph in regions of strong water absorption is exploited to enable the separation of arterial-pulse-related signal from a motion artifact signal. By measuring the optical plethysmograph at a wavelength where water is the dominant absorber, the change in tissue optical properties associated with motion or pressure can be measured, with little interference from the underlying arterial pulsation. Plethysmographs at four near-infrared wavelengths measured through a human ear undergoing occasional motion are shown in FIG. 6, in absorbance units vs. scaled time (i.e., time per point is 43 ms). At approximately 920 nm, where hemoglobin absorption is strong and water absorption is weak, the plethysmograph contains regular arterial pulsations that are interrupted occasionally by motion-related events. As the wavelength is increased to approximately 1300 nm, where water is the predominant absorber, the arterial pulsations diminish and the measured signal becomes largely due to the motion-related events.

[0032] By combining the plethysmograph measured in a spectral region where water is the dominant absorber with a plethysmograph measured where blood is a major absorber, the motion-related signal can be selectively removed. FIG. 7 shows the plethysmograph of a human ear measured at approximately 920 nm, and the result of subtracting a portion of the plethysmograph measured at approximately 1180 nm from that measured at 920 nm. In particular, FIG. 7 shows the plethysmograph of a human ear measured at 920 nm, and the result of subtracting approximately 60% of the plethysmograph measured at approximately 1180 nm from that measured at approximately 920 nm. The 60% value is chosen since at this wavelength, the absorbance of water is approximately 60% higher than that of oxy-hemoglobin. For different wavelength combinations, other multipliers are used based on the ratios of the absorbance of water as compared to that of oxy-hemoglobin or based on empirical determination(s).

[0033] By applying the same analysis to a diverse pool of 36 patients measured in a hospital setting, an average signal to noise increase of a factor of 2 of the plethysmograph at 910 nm was observed. By allowing the multiplier for the 1180 nm plethysmograph to vary, higher signal to noise improvements are achieved.

[0034] Theoretical Model

[0035] The following derivation demonstrates a mechanism by which the effect of motion-induced changes in optical scattering on a plethysmograph measured at one wavelength can be compensated by plethysmographic measurement at a second wavelength. This derivation is provided as one example of the type of motion-induced optical changes that can be compensated, but is not the only mechanism by which the present invention may function, and thus is not meant to limit the embodiments of the present invention.

[0036] A starting point for the analysis is the diffusion theory of light transport in tissue (for example, see "Diffu-

sion Theory of Light Transport”, Willem M. Star, in Optical-Thermal Response of Laser-Irradiated Tissue, edited by Ashley J. Welch and Martin J. C. van Gemert, Plenum Press, New York, 1995, pgs. 131-206). In the case where the transport-corrected scattering coefficient,  $\mu'_s$ , is much larger than the absorption coefficient,  $\mu_a$ , the diffuse intensity of light,  $I(\lambda)$ , measured at wavelength,  $\lambda$ , by a detector positioned a distance,  $l$ , away from a light source, can be described as follows (for example, see “Measurement of Blood Hematocrit by Dual-Wavelength Near-IR Photoplethysmography”, Schmitt, J. M.; Guan-Xiong, G.; Miller, J., SPIE, Vol. 1641, 1992, pgs. 150-161):

$$I(\lambda) \propto \exp(-l\sqrt{3\mu_a(\lambda)\mu'_s(\lambda)}) \quad (\text{eqn. 1})$$

[0037] For small changes in the absorption coefficient, such as those caused by arterial pulsation, the resulting change in intensity can be described by the derivative of intensity with respect to the absorption coefficient:

$$\frac{dI(\lambda)/d\mu_a(\lambda)}{I(\lambda)} = \frac{AC(\lambda)}{DC(\lambda)} = l\sqrt{\frac{3\mu_s(\lambda)}{4\mu_a(\lambda)}} \Delta V^{art} \mu_a^{art}(\lambda) \quad (\text{eqn. 2})$$

[0038] where  $\Delta V^{art}$  is the fractional volume change due to arterial pulsation,  $\mu_a^{art}$  is the absorption coefficient of the arterial blood under measurement,  $AC(\lambda)$  refers to the time varying portion of the optical signal and  $DC(\lambda)$  refers to the average or non-time varying portion of the optical signal.

[0039] The arterial oxygen saturation,  $SPO_2$ , is estimated if the AC-DC ratio described by equation 2 is measured at two wavelengths,  $\lambda_1$  and  $\lambda_2$ , that are chosen so that oxy- and deoxy-hemoglobin are readily differentiated (e.g.,  $\lambda_1$ ~approximately 660 nm,  $\lambda_2$ ~approximately 910 nm):

$$R = \frac{AC(\lambda_1)/DC(\lambda_1)}{AC(\lambda_2)/DC(\lambda_2)} = \Omega_{12} \frac{\mu_a^{art}(\lambda_1)}{\mu_a^{art}(\lambda_2)} \quad (\text{eqn. 3a})$$

where: (eqn. 3b)

$$\Omega_{12} = \sqrt{\frac{\mu'_s(\lambda_1)\mu_a(\lambda_2)}{\mu'_s(\lambda_2)\mu_a(\lambda_1)}}$$

from which: (eqn. 3c)

$$SpO_2 = \frac{\mu_a^{HHb}(\lambda_1) - R\Omega_{12}^{-1}\mu_a^{HHb}(\lambda_2)}{R\Omega_{12}^{-1}(\mu_a^{O_2Hb}(\lambda_2) - \mu_a^{HHb}(\lambda_2)) + \mu_a^{HHb}(\lambda_1) - \mu_a^{O_2Hb}(\lambda_1)}$$

[0040] where  $\mu_a^{HHb}$  and  $\mu_a^{O_2Hb}$  are the respective absorption coefficients for deoxy- and oxy-hemoglobin in arterial blood, and  $R$  is the ratio of the AC to DC ratios.

[0041] The effect of small changes in the scattering coefficient, such as may be brought about by compression of tissue or motion artifact, are as set forth below by eqn. 4:

$$\frac{dI(\lambda)/d\mu'_s(\lambda)}{I(\lambda)} = \frac{AC(\lambda)}{DC(\lambda)} = -l\sqrt{\frac{3\mu_a(\lambda)}{4\mu'_s(\lambda)}} \Delta\mu'_s(\lambda) \quad (\text{eqn. 4})$$

[0042] By measuring the AC-DC ratio at a third wavelength,  $\lambda_3$ , chosen so that the absorption due to hemoglobin

is weak but the absorption due to water is strong, the effect of the motion-induced scattering change are removed from the AC-DC measurement at  $\lambda_2$  by subtracting the scaled AC-DC measurement at  $\lambda_3$ . The resulting motion-corrected plethysmograph,  $P$ , can be expressed as:

$$P = \frac{AC(\lambda_2)}{DC(\lambda_2)} - \frac{AC(\lambda_3)}{DC(\lambda_3)} \Omega_{23}^{-1} \quad (\text{eqn. 5a})$$

where: (eqn. 5b)

$$\Omega_{23} = \sqrt{\frac{\mu'_s(\lambda_2)\mu_a(\lambda_3)}{\mu'_s(\lambda_3)\mu_a(\lambda_2)}}$$

[0043] When the effects of arterial pulsation (equation 2) and motion artifact (equation 4) are additive, equation 5 is expanded as follows:

$$P = -l\sqrt{\frac{3\mu'_s(\lambda_2)}{4\mu_a(\lambda_2)}} \Delta V^{art} \mu_a^{art}(\lambda_2) - l\sqrt{\frac{3\mu_a(\lambda_2)}{4\mu'_s(\lambda_2)}} \Delta\mu'_s(\lambda_2) + \Omega_{23}^{-1} \left[ l\sqrt{\frac{3\mu'_s(\lambda_3)}{4\mu_a(\lambda_3)}} \Delta\mu_a(\lambda_3) + l\sqrt{\frac{3\mu_a(\lambda_3)}{4\mu'_s(\lambda_3)}} \Delta\mu'_s(\lambda_3) \right] \quad (\text{eqn. 6})$$

[0044] When water absorption dominates the absorption of light by tissue at  $\lambda_3$ , and the water concentration in the arteries and surrounding tissue is nearly equal,  $\Delta\mu_a(\lambda_3)$  is approximately zero, and equation 6 simplifies to:

$$P = -l\sqrt{\frac{3\mu'_s(\lambda_2)}{4\mu_a(\lambda_2)}} \Delta V^{art} \mu_a^{art}(\lambda_2) \quad (\text{eqn. 7})$$

[0045] Equation 7 depends only on the effect of arterial pulsation at  $\lambda_2$ ; the effect of the motion artifact has been removed. In a similar manner the plethysmograph measured at **23** may be used to remove the motion effects from the plethysmograph measured at  $\lambda_1$ . The corrected plethysmographs measured at  $\lambda_1$  and  $\lambda_2$  may then be combined and used to estimate oxygen saturation, as described, for example, by equation 3.

[0046] Several wavelengths in the range between approximately 900 and 1300 nm and more specifically in the range between approximately 1150 and 1350 nm have been tested and found effective at reducing motion-artifact from plethysmographs measured at approximately 910 nm. Wavelengths at the longer wavelength side of this range have the advantage of weaker absorbance of hemoglobin compared to that of water (for example, see FIGS. 3 and 4). However, wavelengths at the shorter end of this range have the advantage of reduced variation with changing tissue composition. As can be seen in FIG. 5, where the major components of tissue have been normalized to equal volume fraction, water, lipid, and non-hemoglobin protein all have approximately equal absorbance at approximately 1185 nm. Therefore the absorbance of tissue at approximately 1185 nm will vary little with changes in the relative concentration of these principal components.

[0047] It is known that the detection of light beyond approximately 1100 nm cannot readily be accomplished

with the silicon (Si) detectors that are commonly employed in commercial oximeters. For example, the detector used to collect the data displayed in FIGS. 2-7 employed Indium Gallium Arsenide (InGaAs) as the photosensitive material. The most common type of InGaAs detectors are sensitive to light between approximately 800 and 1700 nm. Therefore, in a pulse oximeter designed in accordance with the embodiments of the present invention, with the conventional wavelengths of 660 and 890 nm, in addition to a new light source that emits at wavelengths that are absorbed strongly by water (such as approximately 1180 nm or approximately between 900-1400 nm), an additional detector(s) is used. One such scheme employs two detectors, one Si and one InGaAs, placed side-by-side. An alternative arrangement uses a collinear ("sandwich") detector containing separate Si and InGaAs layers, such as those commercially available, for example, from the Hamamatsu corporation. Alternately, a germanium detector (Ge) is used as a substitute for the InGaAs detector.

[0048] In addition, an alternative to the above-described augmentation to conventional pulse oximetry, is an all-NIR pulse oximeter. An example of an all NIR oximeter is an oximeter employing light sources emitting at approximately 940, 1040, and 1180 nm used in conjunction with a single InGaAs detector. In addition to the advantage of requiring only one detector, the all-NIR implementation has advantages associated with the optical properties of tissue. The accuracy of measurements made using pulse oximetry depends, in part, on the extent to which the paths traveled by the different colors of light are the same. The mean path length and penetration depth of light at a particular wavelength traveling through tissue is strongly affected by the absorption and scattering coefficients of tissue at that wavelength. In conventional pulse oximetry, in order to achieve the same mean path length and penetration depth at two wavelengths, the scattering and absorption coefficients at the two wavelengths need to be matched. The scattering of light by tissue decreases rapidly as a function of wavelength, with the result that the scattering properties of tissue at approximately 940, 1040, and 1180 nm will be more closely matched than the scattering properties of tissue at a combination of both visible and NIR wavelengths such as approximately 660, 890, and 1180 nm, for reasons discussed below. The absorption properties of oxy- and deoxy-hemoglobin are such that at high oxygen saturation values the net (i.e., combined effects of oxy and deoxy) absorption coefficient due to hemoglobin will be matched reasonably well at 660 nm and 940 nm. However, as oxygen saturation values decrease, the high absorption coefficient of deoxy-hemoglobin at approximately 660 nm will result in an increasingly strong mismatch between the net absorption coefficient of hemoglobin at approximately 660 and approximately 940 nm. The net absorption coefficients of hemoglobin at approximately 940 and approximately 1040 nm, will be more closely matched than at approximately 660 and approximately 940 nm, over the full range of measurable oxygen saturation values.

[0049] The choice of the wavelength used to measure the motion-artifact signal depends partially on the need for matching the optical path length to that of the signals to be corrected. Beyond approximately 950 nm, the absorption coefficient of water, protein, and non-hemoglobin protein, in addition to that of hemoglobin needs to be considered in order to achieve close matching of path lengths. Although

about 1185 nm is a currently preferred wavelength for measuring the motion-artifact signal, other alternative wavelength values are also effective, for example, wavelengths between approximately 1050 and 1400 nm and between approximately 1500 and 1850 nm.

[0050] The embodiments of the present invention may be practiced by placing the optical components directly at the tissue interface, or alternatively, by transporting the light to and from the tissue with fiber optics. The former implementation has the advantage of more efficient delivery and collection of the light, whereas the latter implementation has the advantages of being less costly. The less costly solution is enabled by the fact that when employing fiber optic delivery, the light sources and detectors can reside in the monitor as opposed to the sensor, and considering that such components may be more expensive than the fiber, this will result in a less expensive device.

[0051] The embodiments of the present invention have several advantages over known methods of addressing the results of motion artifacts, as discussed below. The embodiments of the present invention provide methods and devices for measuring the motion signal associated with changes in tissue optical properties and using the measurement to compensate plethysmographic measurements made at other wavelengths. By measuring the artifact signal, the embodiments of the present invention allow motion artifact to be separated from the plethysmographic signal without the limiting assumptions of the prior known techniques. Embodiments of the present invention have the advantage that in addition to identifying the motion, they provide a method of removing the motion artifact and continuing to measure the oxygen saturation during the motion.

[0052] As will be understood by those skilled in the art, other equivalent or alternative methods for the measurement of motion artifact signal associated with changes in tissue optical properties, and using the measurement to compensate plethysmographic measurements made at other wavelengths, according to the embodiments of the present invention can be envisioned without departing from the essential characteristics thereof. For example, a combination of visible and NIR or an all NIR wavelength combination may be used to make the measurements. Moreover, individuals skilled in the art of near-infrared spectroscopy would recognize that additional terms can be added to the algorithms used herein to incorporate reflectance measurements made at additional wavelengths and thus improve accuracy further. Also, light sources or light emission optics other than LED's including and not limited to incandescent light and narrow-band light sources appropriately tuned to the desired wavelengths and associated light detection optics may be placed near the tissue location or may be positioned within a remote unit; and which deliver light to and receive light from the tissue location via optical fibers. Additionally, sensor arrangements functioning in a back-scattering or a reflection mode to make optical measurements of reflectances, as well as other embodiments, such as those working in a forward-scattering or a transmission mode may be used to make these measurements. These equivalents and alternatives along with obvious changes and modifications are intended to be included within the scope of the present invention. Accordingly, the foregoing disclosure is intended to be illustrative, but not limiting, of the scope of the invention which is set forth in the following claims.

What is claimed is:

1. A method of measuring a physiological parameter, comprising:

obtaining a first signal corresponding to a first wavelength of light passing through a tissue, wherein the first wavelength is in the near infrared region of the spectrum, and wherein light at the first wavelength is primarily absorbed by hemoglobin;

obtaining a second signal corresponding to a second wavelength of light passing through the tissue, wherein the second wavelength is in the near infrared region of the spectrum, and wherein light at the second wavelength is primarily absorbed by hemoglobin; and

determining a value for oxygen saturation of the tissue based on the first signal and the second signal.

2. The method of claim 1, wherein the first wavelength and the second wavelength are between about 800 nm and 1100 nm.

3. The method of claim 2, wherein the first wavelength is about 940 nm and wherein the second wavelength is about 1040 nm.

4. A method of measuring a physiological parameter, comprising:

obtaining a first signal corresponding to a first wavelength of light passing through a tissue, wherein the first wavelength is in the near infrared region of the spectrum, and wherein light at the first wavelength is primarily absorbed by hemoglobin;

obtaining a second signal corresponding to a second wavelength of light passing through the tissue, wherein the second wavelength is in the near infrared region of the spectrum, and wherein light at the second wavelength is primarily absorbed by hemoglobin;

obtaining a third signal corresponding to a third wavelength of light passing through the tissue, wherein the third wavelength is in the near infrared region of the spectrum, and wherein light at the third wavelength is primarily absorbed by water;

combining the first signal with the third signal to obtain a first noise-corrected signal;

combining the second signal with the third signal to obtain a second noise-corrected signal; and

determining a value for oxygen saturation of the tissue based on the first noise-corrected signal and the second noise-corrected signal.

5. The method of claim 4, wherein the first wavelength and the second wavelength are between about 800 nm and 1100 nm.

6. The method of claim 5, wherein the first wavelength is about 940 nm and wherein the second wavelength is about 1040 nm.

7. The method of claim 4, wherein the third wavelength is between about 1100 nm and 1400 nm.

8. The method of claim 7, wherein the third wavelength is about 1180 nm.

9. A sensor for use in measuring a physiological parameter, comprising:

a first light emitter configured to irradiate a tissue with light at a first wavelength, wherein the first wavelength

is in the near infrared region of the spectrum, and wherein light at the first wavelength is primarily absorbed by hemoglobin;

a second light emitter configured to irradiate the tissue with light at a second wavelength, wherein the second wavelength is in the near infrared region of the spectrum, and wherein light at the second wavelength is primarily absorbed by hemoglobin; and

a light detector configured to detect light returned from the tissue, wherein the light detector generates a first signal corresponding to the absorbance of light at the first wavelength by the tissue, and wherein the light detector generates a second signal corresponding to the absorbance of light at the second wavelength by the tissue.

10. The sensor of claim 9, wherein the first wavelength and the second wavelength are between about 800 nm and 1100 nm.

11. The sensor of claim 10, wherein the first wavelength is about 940 nm and wherein the second wavelength is about 1040 nm.

12. The sensor of claim 9, comprising:

a third light emitter configured to irradiate the tissue with light at a third wavelength, wherein the third wavelength is in the near infrared region of the spectrum, wherein light at the third wavelength is primarily absorbed by water, wherein the light detector is configured to detect light returned from the tissue at the third wavelength, and wherein the light detector generates a third signal corresponding to the absorbance of light at the third wavelength by the tissue.

13. The sensor of claim 12, wherein the third wavelength is between about 1100 nm and 1400 nm.

14. The sensor of claim 13, wherein the third wavelength is about 1180 nm.

15. A pulse oximeter comprising:

a processor configured to determine a value for oxygen saturation of a tissue from a first signal and a second signal, wherein the first signal corresponds to a first wavelength of light passing through the tissue and the second signal corresponds to a second wavelength of light passing through the tissue, and wherein the first wavelength and the second wavelength are in the near infrared region of the spectrum and primarily absorbed by hemoglobin in the tissue.

16. The pulse oximeter of claim 15, wherein the first wavelength and the second wavelength are between about 800 nm and 1100 nm.

17. The pulse oximeter of claim 16, wherein the first wavelength is about 940 nm and wherein the second wavelength is about 1040 nm.

18. A pulse oximeter comprising:

a processor configured to determine a value for oxygen saturation of a tissue from a first signal, a second signal, and a third signal, wherein the first signal corresponds to a first wavelength of light passing through the tissue, the second signal corresponds to a second wavelength of light passing through the tissue, and the third signal corresponds to a third wavelength of light passing through the tissue, and wherein the first wavelength and the second wavelength are in the near infrared region of the spectrum and primarily absorbed by hemoglobin in

the tissue and the third wavelength is in the near infrared region of the spectrum and primarily absorbed by water in the tissue.

**19.** The pulse oximeter of claim 18, wherein the processor is configured to combine the first signal with the third signal to obtain a first noise-corrected signal, combine the second signal with the third signal to obtain a second noise-corrected signal, and determine the value for oxygen saturation of the tissue based on the first noise-corrected signal and the second noise-corrected signal.

**20.** The pulse oximeter of claim 18, wherein the first wavelength and the second wavelength are between about 800 nm and 1100 nm.

**21.** The pulse oximeter of claim 20 wherein the first wavelength is about 940 nm and wherein the second wavelength is about 1040 nm.

**22.** The pulse oximeter of claim 18, wherein the third wavelength is between about 1100 nm and 1400 nm.

**23.** The pulse oximeter of claim 22, wherein the third wavelength is about 1180 nm.

\* \* \* \* \*

专利名称(译)	利用水近红外吸收脉搏血氧饱和度运动伪影		
公开(公告)号	<a href="#">US20080009690A1</a>	公开(公告)日	2008-01-10
申请号	US11/901643	申请日	2007-09-18
[标]申请(专利权)人(译)	内尔科尔普里坦贝内特公司		
申请(专利权)人(译)	NELLCOR PURITAN BENNETT LLC		
当前申请(专利权)人(译)	COVIDIEN LP		
[标]发明人	DEBRECZENY MARTIN BAKER CLARK R JR		
发明人	DEBRECZENY, MARTIN BAKER, CLARK R. JR.		
IPC分类号	A61B5/02 A61B5/00 A61B5/024		
CPC分类号	A61B5/02416 A61B5/7207 A61B5/14551		
其他公开文献	US8195263		
外部链接	<a href="#">Espacenet</a> <a href="#">USPTO</a>		

摘要(译)

一种用于测量生理参数的方法和装置，其基于获得从通过第一波长的组织部分传输的电磁能获得的第一信号起作用，所述第一信号包括与运动相关事件对应的信号部分和对应的信号部分对于动脉搏动事件，其中在第一波长水是组织部分中电磁能量的主要吸收体；获得从通过第二波长的组织部分传输的电磁能获得的第二信号，第二信号包括与运动相关事件对应的信号部分和与动脉脉动事件对应的信号部分，其中在第二波长处血红蛋白占优势组织部分的电磁能量吸收器；并且组合第一信号和第二信号以产生组合的体积描记器信号，使得组合信号具有与运动相关事件相对应的信号部分，该信号部分小于第一信号或第二信号中存在的运动相关事件。

