



(19) **United States**

(12) **Patent Application Publication** (10) **Pub. No.: US 2004/0161853 A1**

Yang et al.

(43) **Pub. Date: Aug. 19, 2004**

(54) **IMPLANTABLE CHEMICAL SENSOR WITH RUGGED OPTICAL COUPLER**

(52) **U.S. Cl. 436/164; 422/82.05**

(76) **Inventors: Zhongping Yang, Woodbury, MN (US); James K. Carney, Eden Prairie, MN (US); Roy C. Martin, Maple Grove, MN (US)**

(57) **ABSTRACT**

Correspondence Address:
MEDTRONIC, INC.
710 MEDTRONIC PARKWAY NE
MS-LC340
MINNEAPOLIS, MN 55432-5604 (US)

A method and apparatus is provided for determining a property of an analyte using a sensing layer whose optical response changes with the analyte. The apparatus includes a housing with an optically transparent window for receiving the sensing layer. The window passes optical stimulation to the sensing layer and the optical response from the sensing layer. A stimulating light emitter is coupled to a first face of an optical body monolithically coupled to the window and a light detector is coupled to a second face of the optical body for receiving the response. The optical response changes as the concentration of the analyte changes. Reference molecules included in the sensing layer can provide a calibration signal to a second light detector mounted on a third face of the optical body. The first, second and third faces of the optical body are different and not coplanar.

(21) **Appl. No.: 10/365,798**

(22) **Filed: Feb. 13, 2003**

Publication Classification

(51) **Int. Cl.⁷ G01N 21/00**

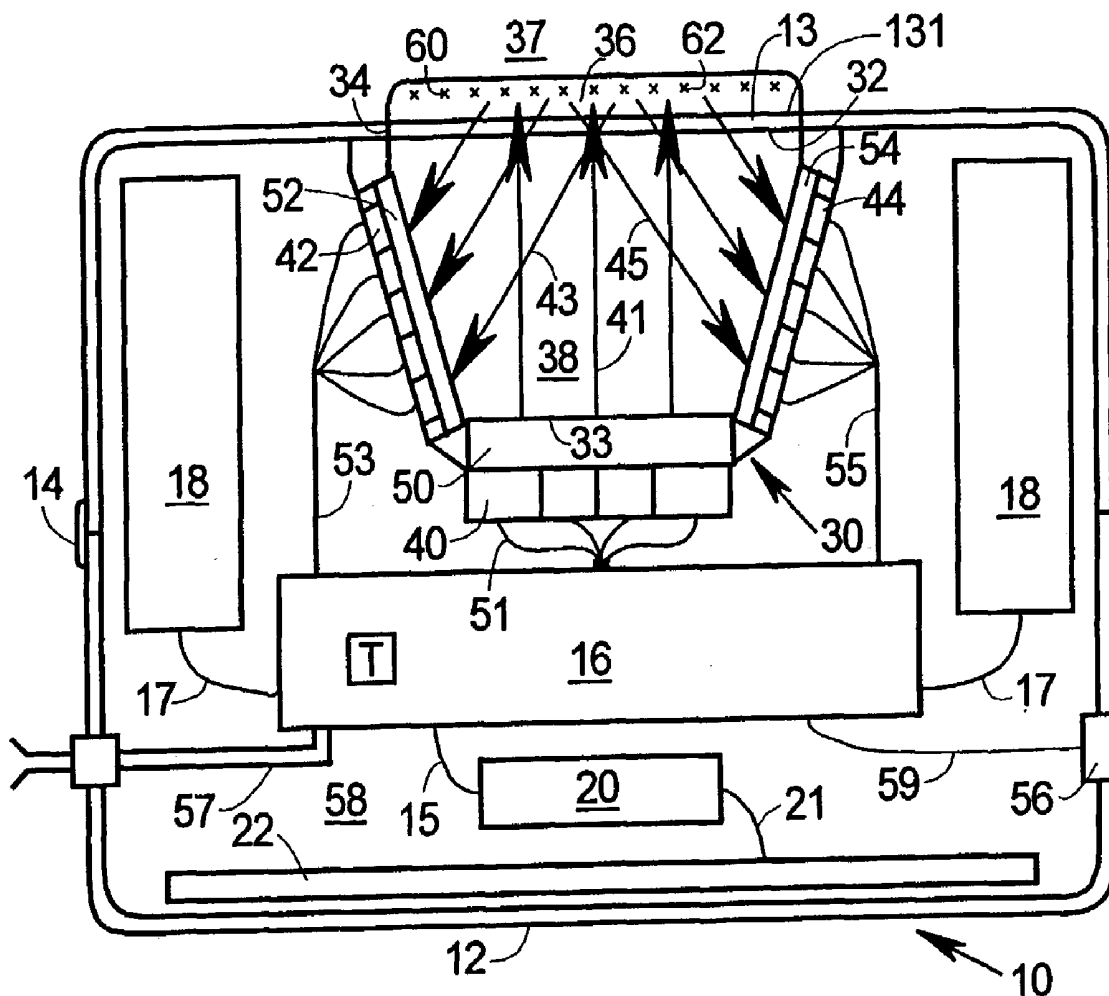

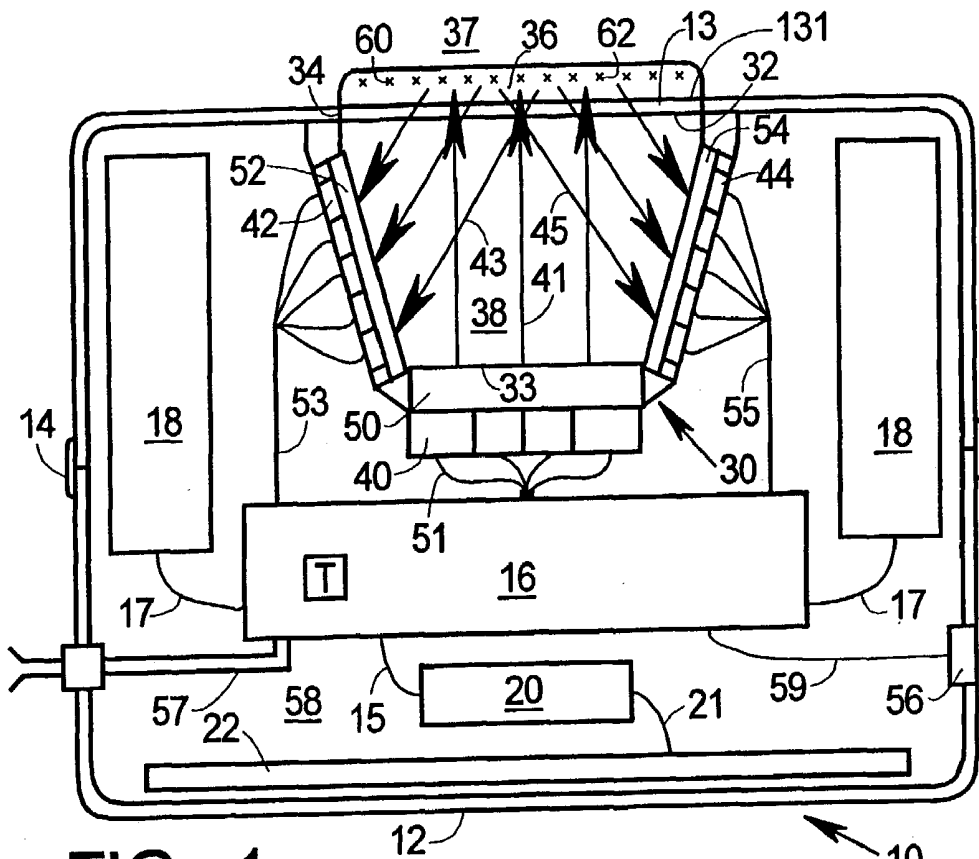

FIG. 1

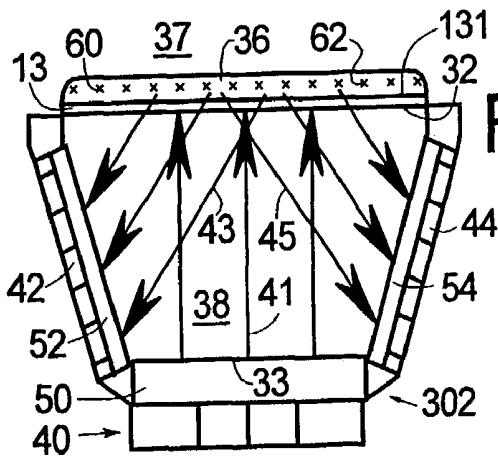

FIG. 2

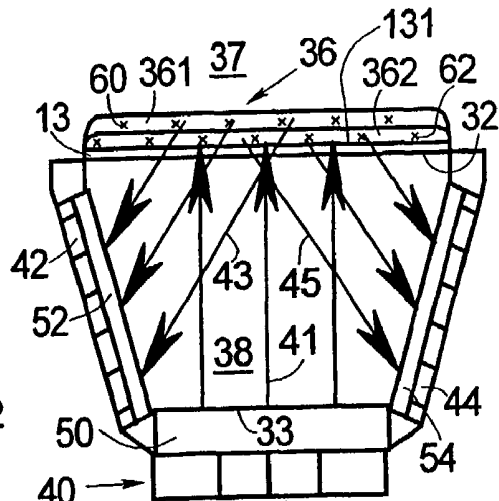

FIG. 3

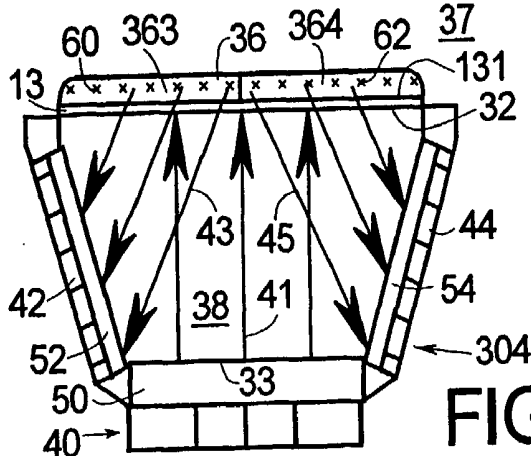

FIG. 4

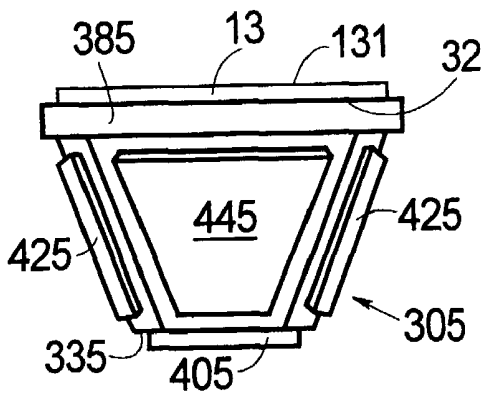

FIG. 5A

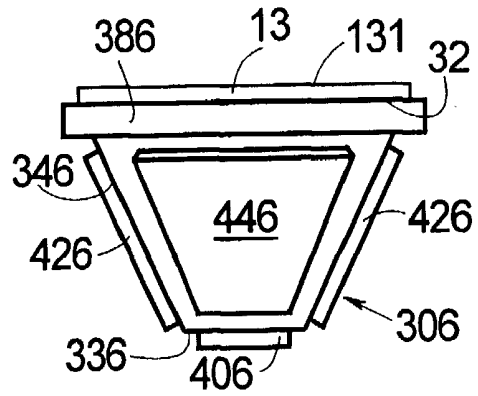

FIG. 6A

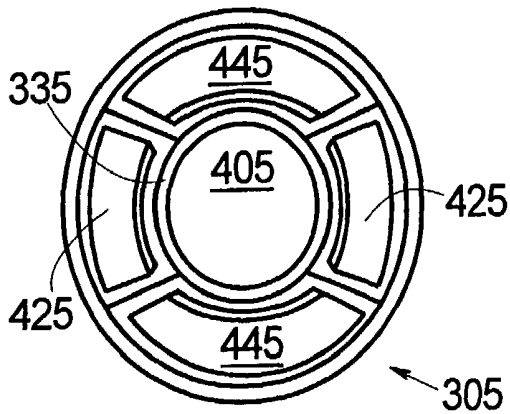

FIG. 5B

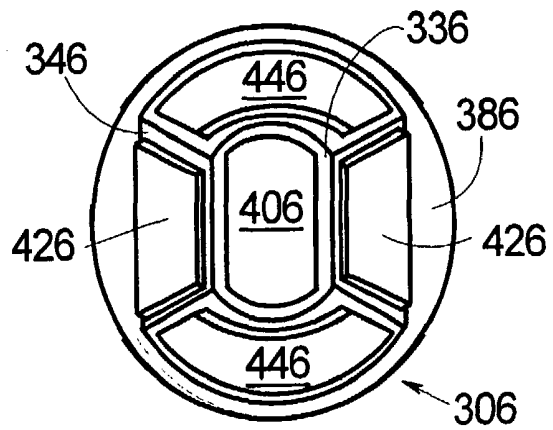

FIG. 6B

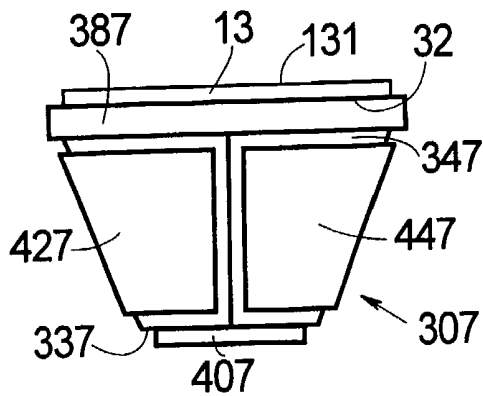

FIG. 7A

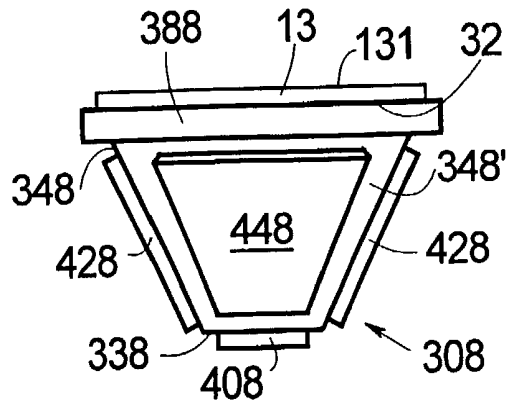

FIG. 8A

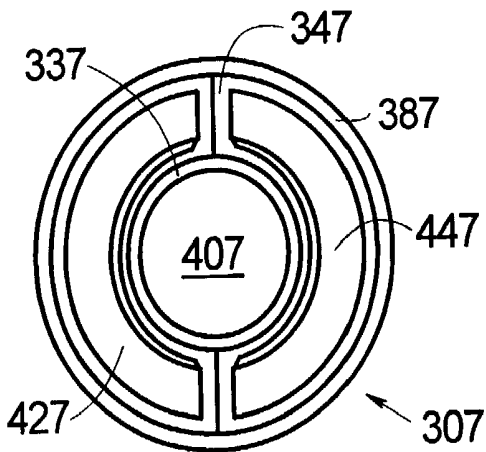

FIG. 7B

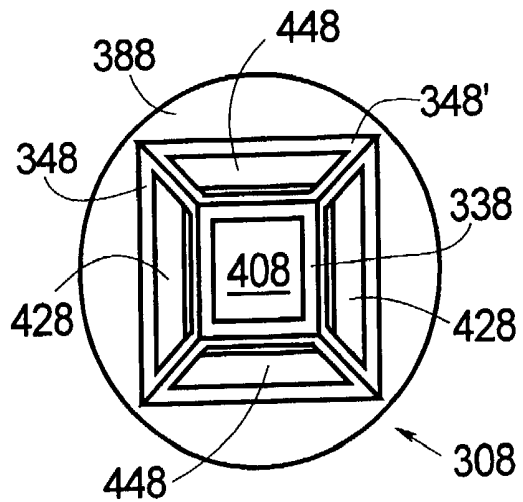

FIG. 8B

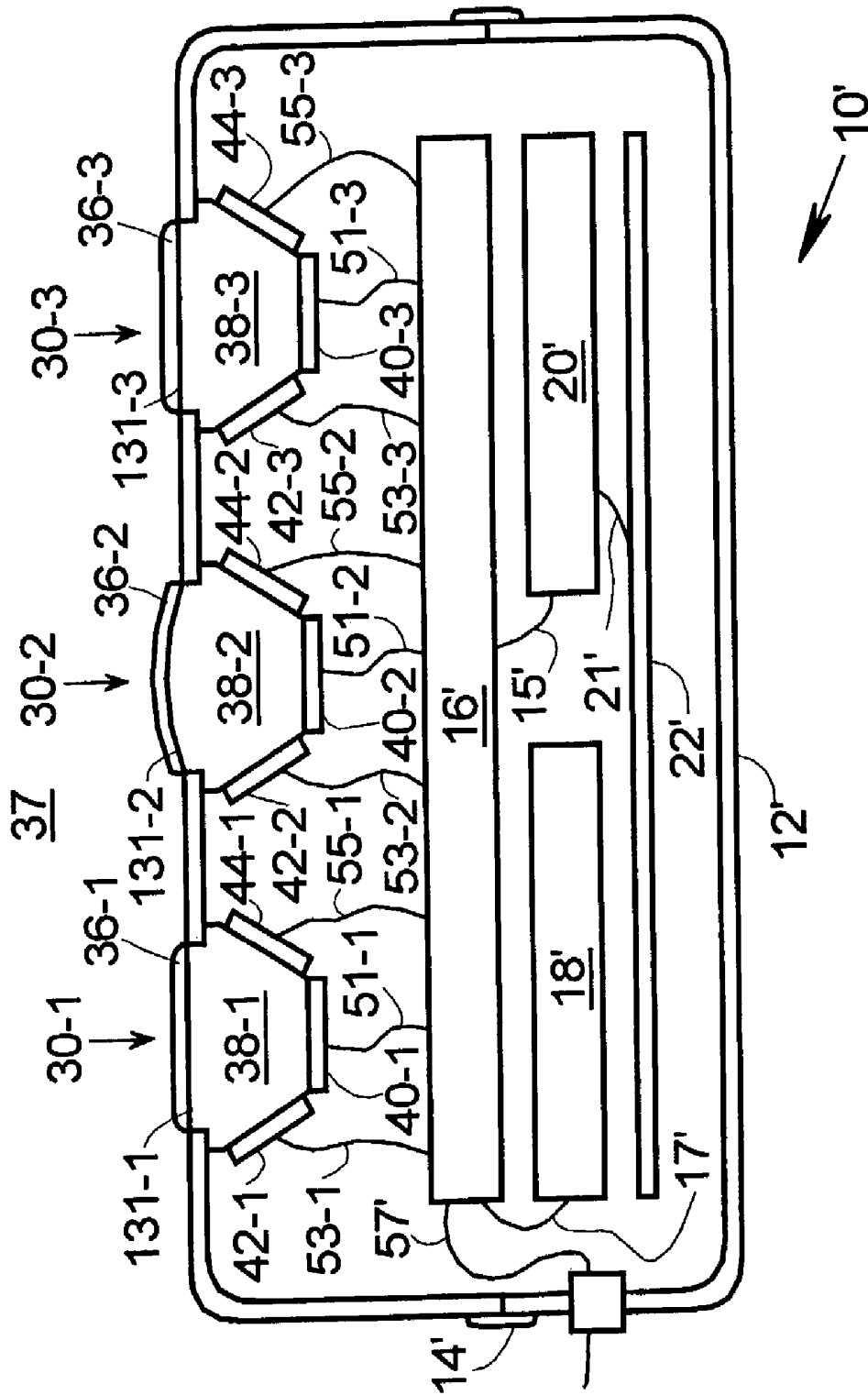

FIG. 9

IMPLANTABLE CHEMICAL SENSOR WITH RUGGED OPTICAL COUPLER

FIELD OF THE INVENTION

[0001] The present invention generally relates to sensors for measuring one or more parameters or of a sample fluid, and more particularly relates to implantable sensors for in situ measurement of parameters of body fluids.

BACKGROUND OF THE INVENTION

[0002] It is known in the art to use electro-optical sensing devices for detecting the presence or concentration of an analyte (i.e., a parameter to be measured) in a liquid or gaseous medium. For example, U.S. Pat. Nos. 6,454,710, 6,330,464, 6,304,766, 6,119,028, 6,081,736, 5,910,661, 5,894,351 and 5,728,422 describe various aspects of this technology including self-contained sensing devices stated to be suitable for use in humans for in-situ detection of various analytes.

[0003] Compact chemical sensors able to detect analytes of interest in connection with human and animal health are of great practical utility, especially arrangements that are implantable. The most common optical chemical sensor configuration uses an LED to provide stimulating light that is optically coupled to an indicator layer in or on which are placed molecules whose fluorescence or absorption is affected by the presence of the analyte, that is, the parameter desired to be measured. A photodetector is likewise optically coupled to the indicator layer for detecting the amount of fluorescence, fluorescence quenching or absorption created by the interaction of the indicator molecules in the presence of the stimulating light and the analyte. In this way, the concentration of sugars, oxygen and other parameters or analytes of interest can be measured in situ. Various configurations and arrangements are used for coupling the stimulating light to the indicator molecules and the optical response thereof back to the photodetectors, as for example, optical fibers or wave guides, or optically transparent encapsulating material.

[0004] However the prior art devices and methods suffer from a number of limitations, as for example, high cost, fragile construction, difficult manufacturing, inefficient optical coupling and limited sensitivity under some circumstances. Accordingly, there continues to be a need for improved sensors, especially implantable sensors that are rugged, highly integrated, easily manufactured and functional for detecting the presence and/or amount of various analytes or parameters in situ in human and animal bodies and that generate little or no adverse reactions within the body. Furthermore, other desirable features and characteristics of the present invention will become apparent from the subsequent detailed description of the invention and the appended claims, taken in conjunction with the accompanying drawings and this background of the invention.

BRIEF SUMMARY OF THE INVENTION

[0005] An apparatus is provided for detecting or measuring a parameter of interest, e.g., an analyte, in a sample fluid, comprising: a housing chemically resistant to the sample fluid; a sensor element substantially within the housing, the sensor element having an optically transparent body with a first surface exposed from the housing for receiving a sensor

layer responsive to the parameter of interest in the sample fluid and for receiving a first signal from the sensing layer in response to optical stimulation thereof; wherein the sensor element comprises a light emitter on a second surface of the body, optically coupled to the first surface for providing said optical stimulation; wherein the sensor element comprises a first detector on a third surface of the body, optically coupled to the first surface for detecting the first signal; and wherein of the first, second and third surfaces of the body, two surfaces are opposed and a remaining surface couples the opposed surfaces. The sensor body is preferably monolithic with a truncated cone shape, the sensor layer being on the base of the cone, the light emitter on the top of the cone and the detectors mounted on inward sloping sides of the cone. In a further embodiment, several sensor elements adapted to measure different analytes are located in a common housing.

[0006] A method is provided for determining a property of an analyte using a sensing layer exposed to the analyte whose response to optical stimulation changes in the presence of the analyte, comprising: providing the sensing layer exposed to the analyte on an optically transparent surface of a monolithic optical body in a housing; passing the optical stimulation to the sensing layer from a light emitter coupled to a first face of the monolithic optical body; and passing an optical response from the sensing layer to a first light detector coupled to a second face of the monolithic optical body different from the first face, and wherein the first and second faces are not substantially coplanar.

BRIEF DESCRIPTION OF THE DRAWINGS

[0007] The present invention will hereinafter be described in conjunction with the following drawing figures, wherein like numerals denote like elements, and

[0008] **FIG. 1** is a simplified schematic cross-sectional view of an implantable chemical sensor according to the present invention;

[0009] **FIGS. 2-4** are a simplified schematic side cross-sectional views of the opto-electronic portion of the sensor of **FIG. 1**, showing further details and according to several embodiments;

[0010] **FIGS. 5A-B through 8A-B** are simplified side views (A) and bottom views (B) of the opto-electronic portion of **FIGS. 2-4**, showing further details and according to still further embodiments; and

[0011] **FIG. 9** is a simplified schematic cross-sectional view similar to **FIG. 1** of an implantable chemical sensor according to a still further embodiment of the present invention.

DETAILED DESCRIPTION OF THE INVENTION

[0012] The following detailed description of the invention is merely exemplary in nature and is not intended to limit the invention or the application and uses of the invention. Furthermore, there is no intention to be bound by any theory presented in the preceding background of the invention or the following detailed description of the invention. Persons of skill in the art will understand the general principles of operation of optically stimulated chemical sensors and the sensing layer materials commonly used. Any particular choice of sensing materials and sensing layer structures

depends on the particular analytes of interest. This invention is particularly concerned with the efficient coupling of light to and from the sensing layer and providing a particularly rugged, efficient, easily manufactured and compact chemical sensor structure.

[0013] FIG. 1 is a simplified schematic cross-sectional view of implantable chemical sensor 10 according to the present invention. Chemical sensor 10 comprises hermetic enclosure or housing 12 that is sealable along joint 14. Conveniently located within housing 12 are optical module 30, electronic control module 16, energy source 18 (e.g., one or more batteries), optional transceiver 20, optional antenna 22 and optional pressure sensor 56 having a sensing diaphragm communicating with ambient 37 through an external wall of housing 12. Optical module 30 has therein light emitter(s) 40 coupled to control module 16 via leads 51, light detectors 42, 44 coupled to control module 16 via leads 53, 55, respectively, and other components as will be presently described. Control module 16 is coupled to energy source 18 via lead(s) 17 and to transceiver 20 via lead(s) 15. Transceiver 20 is coupled to antenna 22 via lead(s) 21. While transceiver 20 and antenna 22 are conveniently provided for communicating to and from sensor 10 they are not essential and externally coupled lead(s) 57 may also be used to provide bi-directional communications with sensor 10. Further, while it is desirable that instructions or other commands be able to be sent to sensor 10 while in situ using lead(s) 57 or antenna 22, this is not essential. Sensor 10 can be preprogrammed to merely report measured data after implantation without further instructions from outside.

[0014] Enclosure or housing 12 protects the internal components from the sample fluid. Housing 12 is conveniently opaque although this is not essential. Housing or enclosure 12 is preferably made of a bio-inert material suitable for long-term placement in a human or animal body. Titanium is an example of a suitable material but others materials will also serve. Temperature sensor [T] is also desirably included in control module 16 or elsewhere in housing 12 so as to provide ambient temperature information for adjusting or compensating the various signals processed by control module 16, but this is not essential. Housing 12 may also be conveniently coated with a layer (not shown) of a chemically inert material such as for example, Teflon® or the like.

[0015] Housing 12 has optically transparent window 13 therein with outer surface 131. Window 13 is hermetically attached to housing 12 by, for example, laser welding, soldering or gluing or other appropriate sealing and attachment means well known in the art at, depicted herein for example, perimeter joint 34. Sapphire, quartz, glasses and optically transparent plastics are examples of convenient materials for optical window 13. Other optically materials may also be used. In the preferred embodiment, it is necessary that window 13 be hermetically sealed to housing 12 so as to preclude ambient leakage into housing 12 via the attachment joint (e.g., joint 34) and that window 13 be transparent to the light wavelengths of interest. Window 13 is conveniently joined to or a part of body 38 of optical module 30 at interface 32. Window 13 and body 38 of optical module 30 may be integral, that is, made of a single piece of material, in which case interface 32 is a hypothetical plane internal to body 38, or window 13 and body 38 can be joined at real interface 32, as for example, using optically transparent epoxy or solder glasses or by other means well

known in the art. Either arrangement is useful and the choice depends upon convenience of manufacture and overall optical properties. What is important is that the maximum amount of light be coupled from body 38 to and from sensing layer 36 on surface 131. As used herein, the terms "optical body" and "monolithic optical body" are intended to include both arrangements, e.g., attached or integral windows. Window 13 with outer surface 131 on which sensor layer 36 is supported is shown herein as having flat outer surface 131 in contact with sensor layer 36, but this is merely for convenience of explanation and not intended to be limiting. Surface 131 of window 13 can have a curved or of any other shape in contact with sensor layer 36 provided that such shape does not interfere with optical coupling between sensor layer 36 and optical module 30.

[0016] Optical module 30 has optically transparent body 38 coupled to or integral with surface 131 on which is located sensing layer 36. Body 38 is conveniently formed of the same class of optically transparent materials as discussed in connection with window 13. Sensing layer 36 is exposed to ambient fluid or gases 37 whose composition or properties are desired to be analyzed. Body 38 of optical module 30 couples light energy 41 to sensing layer 36 from light source 40, e.g., one or more LED's. Light energy 41 is generated by light source(s) 40 and conveniently passes through input filter 50 before entering optical body 38. Input filter 50 is useful for selecting from the light emitted by light source(s) 40, just the wavelengths desired to excite sensing layer 36. While optical filter 50 is desirable it is not essential. Light source(s) 40 may be a single larger area LED or other emitter or an array of smaller emitters, such as for example are shown in FIGS. 14. Either arrangement is suitable. While LEDs are a convenient light source and are preferred, other light sources can be used, as for example and not intended to be limiting, electro-luminescent or gas discharge or other types of light sources well known in the art. As used herein, the term "LED" is intended to include these and other types of light sources. While filter 50 is shown as being a single unit, this is not essential and not intended to be limiting. For example, filter 50 may be different over different LEDs making up light source 40 or may have multiple pass-bands so that multiple selected wavelengths emitted from the same or different LEDs are selectively coupled to optical body 38. Thus, LEDs 40 and/or filter 50 need not be restricted to a single wavelength.

[0017] Body 38 of module 30 also couples light energy 43, 45 from sensing layer 36 to various photo detectors 42, 44. Light energy 43, 45 may originate from fluorescence generated in sensing layer 36 by light energy 41 or be a portion of light energy 41 being reflected or scattered back from layer 36. Filter 52 is located between photodetector(s) 42 and optical body 38 and filter 54 is conveniently located between photodetector(s) 44 and optical body 38. Filters 52, 54 conveniently attenuate extraneous light so that photodetectors 42, 44 detect and measure only specific desired wavelengths of light 43, 45 respectively. While filters 52, 54 are desirable they are not essential. Filters 52, 54 should have pass-bands matched to the wavelengths desired to be detected by photodetectors 42, 44, respectively. Photodetectors 42, 44 can comprise a single large area photocell or an array of smaller photocells; either arrangement is useful. In FIGS. 1-4, the arrangement using multiple photocells 42, 44 is illustrated, but this is not essential. As used herein, the

words "photodetector" and "photodetectors" or "photodetector(s)" are intended to include either arrangement.

[0018] While filter-photodetector pairs **42**, **52** and **44**, **54** are ordinarily designed to each detect a particular wavelength, this is not essential and the filter-photodetector pairs can be made up of several filter-photodetector elements capable of detecting different wavelengths. For example, under circumstances where it is desired to independently monitor the output of sensor layer **36** at multiple wavelengths, filter-photodetector pair **42**, **52** may have a first segment that detects a first wavelength and a second segment that independently detects a second wavelength, thus permitting the intensity of the light of the two wavelengths to be compared. Filter-photodetector pair **44**, **54** may be similarly arranged to have multiple independent elements. The present invention and the appended claims are intended to include such variations.

[0019] Stimulating light source **40** is coupled to control module **16** by leads **51**. Photodetector **42** is coupled to control module **16** by leads **53** and photodetector **44** is coupled to control module **16** by leads **55**. The space within housing **12** surrounding and separating components **16**, **18**, **20**, **22**, **30** and the various interconnecting leads or buses is conveniently filled with an inert plastic filler or potting material **58** so as to provide ruggedness, mechanical shock resistance, improved hermeticity and electrical insulation. An aspect of the present invention is that filler material **58** need not be optically transparent thereby offering a wider range of material choices and the opportunity to select more favorable mechanical, electrical and optical properties than available in prior art devices where the internal filler or potting material is used as an optical wave guide or optical pathway from the light emitters to the sensing layer and back to the optical detectors.

[0020] In operation, stimulating light source **40** operating under the control of electronic module **16** generates light **41** that passes through filter **50** and optical body **38** to sensing layer **36**. Sensing layer **36** contains various indicator molecules **60** that, for example, fluoresce when illuminated by light **41**. Indicator molecules **60** are sensitive to the analyte desired to be detected in ambient fluids or gases **37**. In a typical situation, if the desired analyte is present in ambient **37**, the fluorescence, e.g., light **43** emitted by indicator molecules **60**, increases or decreases proportional to the concentration of the analyte to which indicator molecules are sensitive. Such indicator molecules are well known in the art and their choice depends upon ambient **37** and the particular analyte desired to be detected. Fluorescent light **43** passes through incoming filter **52** and is measured by photodetector **42**. Filter **52** is chosen to pass the wavelength of the fluorescence emitted by indicator molecules **60** and attenuate other wavelengths, e.g., the wavelengths of light **41**, **45**.

[0021] In order to increase the measurement accuracy and compensate for difference in temperature and pressure it is desirable to provide a reference signal to which the analyte sensitive signals registered by photodetector **42** may be compared. This is desirably accomplished by including reference indicator molecules **62** in sensing layer **36**. Such reference indicator molecules are well known in the art. Reference indicator molecules **62** are chosen, for example, to fluoresce at a different wavelength than indicator mol-

ecules **60** and to be insensitive to the analyte. Such molecules are well known in the art. Reference molecules **62**, for example, emit fluorescent light **45** that is coupled through optical body **38** and filter **54** to photodetector **44**. Filter **54** desirably attenuates other wavelengths, e.g., of light **41**, **43** so that photodetector **44** measures substantially only the output of reference indicator molecules **62**. The output of photodetector **44** is coupled via leads **55** to electronic control module **16** where the reference signal received by photodetector **44** is used to compensate the analyte sensitive signal from photodetector **42** for changes in conditions.

[0022] Control module **16** conveniently uses transmitter or transceiver **20** to send the test results to antenna **22** where they are broadcast to a receiver outside the body. Persons of skill in the art will understand how to choose transmitter or transceiver frequencies to accomplish this. Similarly, control module **16** can receive program instructions from outside the body via antenna **22** and transceiver **20**. In this way, the operation of control module **16** can be externally programmed to, for example, conduct tests at different times or with different repetition rates or different light stimulation levels and other variations. Alternatively or in combination, externally coupled wires **57** may be used to input instructions to sensor module **10** and receive data therefrom. Either arrangement is suitable.

[0023] FIGS. 2-4 are simplified schematic side cross-sectional views of optical module **30** of sensor **10** of FIG. 1, showing further details and according to several embodiments **302**, **303**, **304**. Like reference numbers identify like elements. FIGS. 2-4 differ only in the composition and arrangement of sensing layer **36**. Other aspects of modules **302**, **303**, **304** are the same as in module **30** of FIG. 1.

[0024] In FIG. 2, sensing layer **36** of optical module **302** has analyte indicator molecules **60** and reference indicator molecules **62** dispersed substantially homogeneously in layer **36**. In optical module **303** of FIG. 3, a layered arrangement is used for sensing layer **36** wherein, for example, analyte indicator molecules **60** are dispersed in layer **361** and reference indicator molecules **62** are dispersed in layer **362**. In module **303** of FIG. 3, layer **361** is shown as superposed on layer **362** but this is merely for convenience of explanation. Those of skill in the art will understand that the order of layers maybe interchanged depending on the analyte and the reference indicator, that is, with layer **362** outermost and layer **361** innermost. Either arrangement suffices depending on the analyte and reference involved. In optical module **304** of FIG. 4, the regions of sensing layer **36** containing analyte indicator molecules **60** and reference indicator molecules **62** are laterally distinct. In optical module **304**, analyte indicator molecules **60** are in region **363** and reference indicator molecules **62** are in region **364**, but these regions may be interchanged. Other lateral separation arrangements may also be used, as for example, regions **363** and **364** may be interspersed in alternate stripes or alternate concentric circles or otherwise and FIG. 4 is merely intended to be illustrative of lateral separation and not limited to the particular arrangement shown. Similarly, the arrangements illustrated in FIGS. 2-4 may be used simultaneously or in combination in different regions of window **13**.

[0025] FIGS. 5A-B through 8A-B are simplified side views (A) and bottom views (B) respectively, of optical

module **30** of FIGS. 1-4, showing further details and according to still further embodiments **305, 306, 307, 308**. Like reference numbers are used for like elements. In FIGS. 5-8, the details of sensing layer **36** are omitted and filter layers **50, 52, 54** are not shown, but this is merely for convenience of explanation and not intended to be limiting. Persons of skill in the art will understand based on the description herein that the variations illustrated in FIGS. 2-4 also apply to optical sensing modules **305-308** of FIGS. 5-8. FIGS. 5-8 illustrate various alternative arrangements **305, 306, 307, 308** of optical sensing module **30** with different location and shapes of photodetector **42** for receiving analyte sensing light signal **43** and photodetector **44** for receiving the reference light signal **45** and photo-emitter **40** for generating stimulating light **41**. For convenience of explanation and not intended to be limiting, in FIGS. 5-8, variations of optical sensing modules **30** are identified by reference numerals **305, 306, 307, 308**, variations of analyte signal detector **42** are identified by reference numerals **425, 426, 427, 428**, variations of reference signal detector **44** are identified by reference numerals **445, 446, 447, 448**, variations of stimulating light emitter **40** are identified by reference numerals **405, 406, 407, 408**, variations of optical body **38** are identified by reference numerals **385, 386, 387, 388** and variations of lower surface **33** of optical body **38** are identified by reference numerals **335, 336, 337, 338**. For simplicity, sensing layer **36** and indicator molecules **60, 62** are omitted from FIGS. 5-8 but those of skill in the art will understand that such are present on window **13** when optical module **30** is present in housing **12**. The explanations provided earlier about elements **30, 33, 38, 42, 44** also apply to the variations identified here.

[0026] FIG. 5A is a side view and FIG. 5B is a bottom view of optical sensing module **305** showing opposed pairs of photodetectors **425** and opposed pairs of photodetectors **445**. Stimulating light emitter **405** is located on bottom surface **335** of electro-optic module **305** opposite outer surface **131** of window **13** on which sensing layer **36** (not shown) would be located. Optical body **385** has a generally truncated cone shape with the larger diameter upper portion mating with housing **12** and surface **131** for supporting sensing layer **36**. Having the photodetectors arranged in opposing pairs increases the optical coupling through optical body **385** and provides a strong signal.

[0027] FIG. 6A is a side view and FIG. 6B is a bottom view of optical sensing module **306** showing opposed pairs of photodetectors **426** and opposed pairs of photodetectors **446**. Stimulating light emitter **406** is located on bottom surface **336** of electro-optic module **306** opposite outer surface **131** on which sensing layer **36** (not shown) would be located. Optical body **386** has a generally truncated cone shape with the larger diameter upper portion mating with housing **12** and surface **131** for supporting sensing layer **36**. The lower, cone-shaped portion has two curved sides on which detectors **426** are located and two flat sides **346** on which detectors **426** are located. Having the photodetectors arranged in opposing pairs increases the optical coupling through optical body **386** and provides a strong signal.

[0028] FIG. 7A is a side view and FIG. 7B is a bottom view of optical sensing module **307** showing photodetectors **427** and photodetectors **447** in an opposed arrangement. Stimulating light emitter **407** is located on bottom surface **337** of electro-optic module **307** opposite outer surface **131**

of window **13** on which sensing layer **36** (not shown) would be located. Optical body **387** has a generally truncated cone shape with the larger diameter upper portion mating with housing **12** and surface **131** for supporting sensing layer **36**. Having the photodetectors arranged so as to lap substantially around side **347** of the cone shape increases the optical coupling through optical body **387** and provides a strong signal.

[0029] FIG. 8A is a side view and FIG. 8B is a bottom view of optical sensing module **308** showing opposed pairs of photodetectors **428** and opposed pairs of photodetectors **448**. Stimulating light emitter **408** is located on bottom surface **338** of electro-optic module **308** opposite outer surface **131** of window **13** on which sensing layer **36** (not shown) would be located. Optical body **388** has a generally truncated pyramid shape with the larger upper portion mating with housing **12** and surface **131** for supporting sensing layer **36**, and opposed flat sides **348, 348'**. Having the photodetectors **428, 448** arranged in opposing pairs increases the optical coupling through optical body **388** and provides a strong signal. As used herein, the term "truncated cone" is intended to include any of the shapes of body portions **385-388** of modules **305-308** shown in FIGS. 5-8 irrespective as to whether the sides of the truncated cone are curved, flat or a combination thereof.

[0030] FIG. 9 is a simplified schematic cross-sectional view similar to FIG. 1, of implantable chemical sensor **10'** according to a still further embodiment of the present invention. Chemical sensor **10'** comprises hermetic enclosure or housing **12'** that is sealable along joint **14'**. Conveniently located within housing **12'** are optical modules **30-1, 30-2, 30-3**, electronic control module **16'**, energy source **18'** (e.g., one or more batteries), optional transceiver **20'** and optional antenna **22'**. Optical modules **30-1, 30-2, 30-3** have therein light emitter(s) **40-1, 40-2, 40-3** coupled to control module **16'** by leads **51-1, 51-2, 51-3**, light detectors **42-1, 42-2, 42-3** and **44-1, 44-2, 44-3** coupled to control module **16'** by leads **53-1, 53-2, 53-3** and **55-1, 55-2, 55-3**, respectively, and other components as will be presently described. Control module **16'** is coupled to energy source **18'** by lead(s) **17'** and to transceiver **20'** by lead(s) **15'**. Transceiver **20'** is coupled to antenna **22'** by lead(s) **21'**. While transceiver **20'** and antenna **22'** are conveniently provided for communicating to and from sensor **10'** they are not essential and externally coupled lead(s) **57'** may also be used. Further, while it is desirable that instructions or other commands be able to be sent to sensor **10'** while in situ using lead(s) **57'** or antenna **22'**, this is not essential. Sensor **10'** can be preprogrammed to merely report measured data after implantation without further instructions from outside.

[0031] Sensor **10'** differs from sensor **10** of FIG. 1 in that sensor **10'** has three optical modules **30-1, 30-2, and 30-3** therein, analogous to module **30** of FIG. 1 and modules **302-308** of FIGS. 2-8. While three optical modules are shown in FIG. 9, persons of skill in the art will understand that this is merely for convenience of explanation and that any number greater than one may be provided in sensor **10'**, consistent with the space limitations where sensor **10'** is intended to be placed and the number of different analytes desired to be simultaneously detected or measured.

[0032] Modules **30-1, 30-2, and 30-3** are hermetically sealed to enclosure **12'** and electrically coupled to control

module 16'. Optical modules 30-1, 30-2, 30-3 have, respectively, optical bodies 38-1, 38-2, 38-3 analogous to optical body 38 of sensor 10, and corresponding light sources 40-1, 40-2, 40-3 and detectors 42-1, 42-2, 42-3 and 44-1, 44-2, 44-3 analogous to light source 40 and detectors 42, 44 of sensor 10 of FIG. 1. Connecting leads 51-1, 51-2, 51-3; 53-1, 53-2, 53-3; and 55-1, 55-2, 55-3 are analogous to leads 51, 53, and 55 of sensor 10 of FIG. 1. For simplicity, separate window(s) 13 and filters 50, 52, 54 are not shown in sensor elements 30-1, 30-2 and 30-3 of FIG. 9 but persons of skill in the art will understand that they can be included as desired. Temperature sensor [T], pressure sensor 56 and light beams 41, 43, 45 shown in FIG. 1 are omitted from FIG. 9 for clarity but this is not intended to be limiting or imply that such features or elements are not included.

[0033] Optical modules 30-1, 30-2, 30-3 have, respectively, outer surfaces 131-1, 131-2, 131-3 analogous to outer surface 131 of FIGS. 1-4, on which are located sensor layers 36-1, 36-2, and 36-3 equivalent to layers 36, 361-364 shown in FIGS. 1-4. Similarly, indicator molecules and reference molecules 60, 62 are omitted from FIG. 9 for simplicity and not intended to be limiting. Optical modules 30-1, 30-2, 30-3 perform substantially the same function as optical modules 30, 302-308 of FIGS. 1-8 in substantially the same way and the discussion and variations associated with FIGS. 1-8 are applicable to modules 30-1, 30-2, 30-3 and sensor 10' of FIG. 9. In FIG. 9, there is further illustrated in module 30-2, the optional use of non-planar outer surface 131-2 supporting sensor layer 36-2.

[0034] Multiple optical modules 30-1, 30-2, 30-3 in sensor 10' are conveniently used with sensor layers 36-1, 36-2, 36-3 of different composition, with different sensing and/or reference molecules. The wavelengths emitted by light sources 40-1, 40-2, 40-3 and the filters used with light sources 40-1, 40-2, 40-3 and with detectors 42-1, 42-2, 42-3 and 44-1, 44-2, 44-3 can be appropriately modified for the different sensing layers intended to respond to different analytes. In this way, different analytes of ambient 37 may be separately monitored at the same time using single implantable sensor 10'. Further, sensor molecules and reference molecules may be placed on different sensor elements rather than combined on the same sensor element in situations where they might undesirably interact. Thus, the use of multiple optical modules in the same housing can greatly enhance the ability to monitor important biological and/or chemical activity in situ in a human or animal body. As used herein, the word "animal" is intended to include any non-human animate organism on land or in the sea or air. Persons of skill in the art will also understand that while the present invention is particularly useful in connection with living organisms, it may also be used in any situation where in situ measurement or detection of particular analytes is desired and relevant sensor molecules are available.

[0035] While at least one exemplary embodiment has been presented in the foregoing detailed description of the invention, it should be appreciated that a vast number of variations exist. It should also be appreciated that the exemplary embodiment or exemplary embodiments are only examples, and are not intended to limit the scope, applicability, or configuration of the invention in any way. Rather, the foregoing detailed description will provide those skilled in the art with a convenient road map for implementing an exemplary embodiment of the invention. It being understood

that various changes may be made in the function and arrangement of elements described in an exemplary embodiment without departing from the scope of the invention as set forth in the appended claims.

What is claimed is:

1. A chemical sensor for detecting or measuring a parameter of interest in a sample fluid, comprising:

- a) a housing chemically resistant to the sample fluid;
- b) a sensor element substantially within the housing, the sensor element having an optically transparent body with a first surface exposed from the housing for receiving a sample responsive to the parameter of interest in the sample fluid and for receiving a first signal from the sensing layer in response to optical stimulation thereof;
- c) wherein the sensor element comprises a light emitter on a second surface of the body, optically coupled to the first surface for providing said optical stimulation;
- d) wherein the sensor element comprises a first detector on a third surface of the body, optically coupled to the first surface for detecting said first signal; and
- e) wherein of the first, second and third surfaces of the body, two surfaces are opposed and a remaining surface couples the opposed surfaces.

2. The sensor of claim 1 wherein the first surface receives a further response from a reference component associated with the sensing layer for providing, in response to optical stimulation, a second signal unaffected by the parameter of interest.

3. The sensor of claim 2 further comprising a second detector on a fourth surface of the body, optically coupled to the first surface for responding to the second signal.

4. The sensor of claim 3 wherein the fourth surface couples the opposed surfaces.

5. The sensor of claim 3 wherein the first and second surfaces are substantially opposed and the third and fourth surfaces are substantially opposed.

6. The sensor of claim 1 further comprising a control module located within the housing and coupled to the sensing element for actuating said stimulation and measuring said first signal.

7. The sensor of claim 6 further comprising a temperature or pressure sensor coupled to the control module.

8. The sensor of claim 1 further comprising:

- i) a control module located within the housing and coupled to the sensing element for actuating said stimulation and measuring said first signal;
- ii) a transmitter located within the housing and coupled to the control module; and
- iii) an antenna located within the housing and coupled to the transmitter for coupling the results of measuring the first signal outside the module.

9. The sensor of claim 1 wherein the first and second surfaces of the sensor element are opposed and the third surface couples the first and second surfaces.

10. The sensor of claim 1 wherein at least one of the opposed surfaces is substantially planar.

11. The sensor of claim 1 further comprising a second sensor element substantially within the same housing, the second sensor element having an optically transparent sec-

ond body with a first surface exposed from the housing for receiving a second layer responsive to a different parameter of interest in the sample fluid and for receiving a first signal from the second sensing layer in response to optical stimulation thereof; wherein the sensor element comprises a light emitter on a second surface of the second body, optically coupled to the first surface for providing said optical stimulation; wherein the second sensor element comprises a first detector on a third surface of the second body, optically coupled to the first surface for detecting said first signal; and wherein of the first, second and third surfaces of the second body, two surfaces are opposed and a remaining surface couples the opposed surfaces.

12. A method for determining a property of an analyte using a sensing layer exposed to the analyte whose response to optical stimulation changes in the presence of the analyte, comprising:

providing the sensing layer exposed to the analyte on an optically transparent surface of a monolithic optical body in a housing;

passing optical stimulation to the sensing layer from a light emitter coupled to a first face of the monolithic optical body; and

passing an optical response from the sensing layer to a first light detector coupled to a second face of the monolithic optical body different than the first face, and wherein the first and second faces are not substantially coplanar.

13. The method of claim 12 further comprising passing a further optical response from the sensing layer to a second light detector coupled to a third face of the monolithic optical body different than the first face, and wherein the first and third faces are not substantially coplanar.

14. The method of claim 13 wherein the second and third passing steps comprise passing the optical response to faces that are not substantially coplanar.

15. The method of claim 13 wherein the third passing step comprises passing the optical response to the second face inclined at a first angle with respect to the first face and to the third face inclined at a second angle with respect to the first face and wherein the first and second angles are obtuse.

16. The method of claim 15 wherein the second and third passing steps comprise passing the responses to faces whose angles total more than 180 degrees.

17. An apparatus for determining a property of an analyte using a sensing layer exposed to the analyte whose optical response to optical stimulation changes in the presence of the analyte, comprising:

a housing;

a first optically transparent window in the housing for receiving the sensing layer, wherein the window passes the optical stimulation to the sensing layer and the optical response from the sensing layer;

a first optical body monolithically coupled to the first window for passing light to and from the sensing layer through the first window;

a first light emitter coupled to a first face of the first optical body for providing the optical stimulation;

a first light detector coupled to a second face of the first optical body different than the first face for receiving a first component of the optical response; and

a second light detector coupled to a third face of the first optical body different than the first and second face, for receiving a second component of the optical response.

18. The apparatus of claim 17 wherein the first optical body has a truncate cone shape with a substantially planar base coupled to the first window and a substantially planar top opposite the base as the first face, and wherein the second and third faces occupy inwardly slanting sides of the truncated cone shape extending from the base.

19. The apparatus of claim 18 wherein the truncated cone has four sides arranged in first and second opposed pairs of sides and first light detector occupies the first opposed pair of sides and the second light detector occupies the second opposed pair of sides.

20. The apparatus of claim 17 further comprising a second optically transparent window in the housing for receiving a further sensing layer, wherein the second window passes a second optical stimulation to the further sensing layer and a further optical response from the further sensing layer; a second optical body monolithically coupled to the second window for passing light to and from the further sensing layer through the second window; a further light emitter coupled to a first face of the second optical body for providing the second optical stimulation; a third light detector coupled to a second face of the second optical body different than the first face for receiving a first component of the further optical response; and a fourth light detector coupled to a third face of the second optical body different than the first and second face, for receiving a second component of the further optical response.

* * * * *

专利名称(译)	植入式化学传感器，坚固的光耦合器		
公开(公告)号	US20040161853A1	公开(公告)日	2004-08-19
申请号	US10/365798	申请日	2003-02-13
[标]申请(专利权)人(译)	杨忠平 CARNEY JAMES K MARTIN ROY C		
申请(专利权)人(译)	杨中平 CARNEY JAMES K. MARTIN ROY C.		
当前申请(专利权)人(译)	杨中平 CARNEY JAMES K. MARTIN ROY C.		
[标]发明人	YANG ZHONGPING CARNEY JAMES K MARTIN ROY C		
发明人	YANG, ZHONGPING CARNEY, JAMES K. MARTIN, ROY C.		
IPC分类号	A61B5/00 G01N21/64 G01N21/77 G01N21/00		
CPC分类号	A61B5/0031 G01N21/6428 G01N21/77 G01N2021/6419 G01N2201/0227 G01N2021/7759 G01N2021/7786 G01N2201/022 G01N2021/6421		
外部链接	Espacenet USPTO		

摘要(译)

提供了一种方法和装置，用于使用其光学响应随分析物变化的传感层来确定分析物的性质。该装置包括具有光学透明窗口的壳体，用于接收传感层。窗口将光学刺激传递到传感层并且来自传感层的光学响应。刺激光发射器耦合到单片耦合到窗口的光学体的第一面，并且光检测器耦合到光学体的第二面以接收响应。光学响应随着分析物浓度的变化而变化。包括在传感层中的参考分子可以向安装在光学体的第三面上的第二光检测器提供校准信号。光学体的第一，第二和第三面是不同的而不是共面的。

