



US009358401B2

(12) **United States Patent**
Gertner

(10) **Patent No.:** **US 9,358,401 B2**
(45) **Date of Patent:** **Jun. 7, 2016**

(54) **INTRAVASCULAR CATHETER TO DELIVER UNFOCUSED ENERGY TO NERVES SURROUNDING A BLOOD VESSEL**

(75) Inventor: **Michael Gertner**, Menlo Park, CA (US)

(73) Assignee: **Kona Medical, Inc.**, Bellevue, WA (US)

(*) Notice: Subject to any disclaimer, the term of this patent is extended or adjusted under 35 U.S.C. 154(b) by 1000 days.

(21) Appl. No.: **13/417,194**

(22) Filed: **Mar. 9, 2012**

(65) **Prior Publication Data**

US 2012/0172723 A1 Jul. 5, 2012

Related U.S. Application Data

(63) Continuation of application No. 12/902,133, filed on Oct. 11, 2010, now Pat. No. 9,174,065, and a continuation-in-part of application No. 12/725,450, filed on Mar. 16, 2010, now abandoned, which is a

(Continued)

(51) **Int. Cl.**
A61B 8/14 (2006.01)
A61N 2/00 (2006.01)

(Continued)

(52) **U.S. Cl.**
CPC **A61N 2/006** (2013.01); **A61B 5/055** (2013.01); **A61B 5/4035** (2013.01); **A61B 5/4041** (2013.01); **A61B 5/4047** (2013.01); **A61B 5/412** (2013.01); **A61B 5/489** (2013.01); **A61B 5/4839** (2013.01); **A61B 5/4893** (2013.01); **A61B 6/032** (2013.01); **A61B 6/037** (2013.01); **A61B 8/00** (2013.01); **A61B 8/06** (2013.01); **A61B 8/08** (2013.01); **A61B 17/320068** (2013.01); **A61B 18/14** (2013.01); **A61B 18/18** (2013.01); **A61N 1/0551** (2013.01); **A61N 5/00** (2013.01); **A61N 5/0601** (2013.01); **A61N 5/062** (2013.01);

(Continued)

(58) **Field of Classification Search**
CPC A61B 2018/00434; A61B 2018/00511; A61B 2019/5276; A61B 6/506; A61B 5/055; A61B 5/489; A61B 5/4893; A61B 18/14; A61N 7/02; A61N 7/00; A61N 2007/0026
See application file for complete search history.

(56) **References Cited**

U.S. PATENT DOCUMENTS

385,256 A 6/1888 Eggers
3,274,437 A 9/1966 Mastrup

(Continued)

FOREIGN PATENT DOCUMENTS

EP 0225120 A2 6/1987
EP 0420758 A1 4/1991

(Continued)

OTHER PUBLICATIONS

Accord et al., "The Issue of Transmurality in Surgical Ablation for Atrial Fibrillation." *Cardiothoracic Surgery Network*: 3pp, Aug. 8, 2005.

(Continued)

Primary Examiner — Mark Remaly

(74) *Attorney, Agent, or Firm* — Vista IP Law Group, LLP

(57) **ABSTRACT**

In some examples, nerves surrounding arteries or leading to organs are targeted with energy sources to correct or modulate physiologic processes. In some examples, different types of energy sources are utilized singly or combined with one another. In some examples, bioactive agents or devices activated by the energy sources are delivered to the region of interest and the energy is enhanced by such agents or the agents are enhanced by the energy sources.

31 Claims, 51 Drawing Sheets

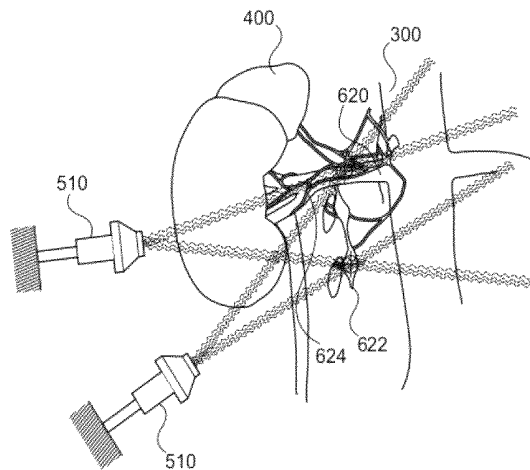

Related U.S. Application Data

	continuation-in-part of application No. 12/685,655, filed on Jan. 11, 2010, now Pat. No. 8,295,912.	4,702,732 A	10/1987	Powers et al.
		4,708,836 A	11/1987	Gain et al.
		4,748,985 A	6/1988	Nagasaki
		4,757,820 A	7/1988	Itoh
		4,770,175 A	9/1988	McEwen
(60)	Provisional application No. 61/377,908, filed on Aug. 27, 2010, provisional application No. 61/347,375, filed on May 21, 2010, provisional application No. 61/256,983, filed on Oct. 31, 2009, provisional application No. 61/250,857, filed on Oct. 12, 2009, provisional application No. 61/261,741, filed on Nov. 16, 2009, provisional application No. 61/291,359, filed on Dec. 30, 2009, provisional application No. 61/303,307, filed on Feb. 10, 2010.	4,773,865 A	9/1988	Baldwin
		4,773,899 A	9/1988	Spears
		4,784,148 A	11/1988	Dow et al.
		4,841,979 A	6/1989	Dow et al.
		4,850,363 A	7/1989	Yanagawa
		4,858,613 A	8/1989	Fry et al.
		4,905,672 A	3/1990	Schwarze et al.
		4,913,155 A	4/1990	Dow et al.
		4,929,246 A	5/1990	Sinofsky
		4,931,047 A	6/1990	Broadwin et al.
		4,938,216 A	7/1990	Lele
		4,938,217 A	7/1990	Lele
		4,957,099 A	9/1990	Hassler
		4,957,481 A	9/1990	Gatenby
		5,005,579 A	4/1991	Wurster et al.
(51)	Int. Cl.	RE33,590 E	5/1991	Dory
	<i>A61B 5/055</i> (2006.01)	5,026,387 A	6/1991	Thomas
	<i>A61B 5/00</i> (2006.01)	5,036,855 A	8/1991	Fry et al.
	<i>A61B 8/00</i> (2006.01)	5,039,774 A	8/1991	Shikinami et al.
	<i>A61B 8/06</i> (2006.01)	5,042,486 A	8/1991	Pfeiler et al.
	<i>A61B 8/08</i> (2006.01)	5,065,742 A	11/1991	Belikan et al.
	<i>A61N 5/06</i> (2006.01)	5,080,101 A	1/1992	Dory
	<i>A61N 7/00</i> (2006.01)	5,080,102 A	1/1992	Dory
	<i>A61N 7/02</i> (2006.01)	5,150,712 A	9/1992	Dory
	<i>A61B 17/32</i> (2006.01)	5,170,790 A	12/1992	Lacoste et al.
	<i>A61B 18/18</i> (2006.01)	5,178,135 A	1/1993	Uchiyama et al.
	<i>A61N 5/00</i> (2006.01)	5,178,148 A	1/1993	Lacoste et al.
	<i>A61B 18/14</i> (2006.01)	5,181,522 A	1/1993	McEwen
	<i>A61N 1/05</i> (2006.01)	5,193,527 A	3/1993	Schaefer
	<i>A61B 5/0225</i> (2006.01)	5,194,291 A	3/1993	D'Aoust et al.
	<i>A61B 6/03</i> (2006.01)	5,211,160 A	5/1993	Talish et al.
	<i>A61B 19/00</i> (2006.01)	5,215,680 A	6/1993	D'Arrigo
	<i>A61B 18/00</i> (2006.01)	5,219,401 A	6/1993	Cathignol et al.
	<i>A61B 6/00</i> (2006.01)	5,230,334 A	7/1993	Klopotek
		5,230,921 A	7/1993	Waltonen et al.
(52)	U.S. Cl.	5,233,994 A	8/1993	Shmulewitz
	CPC <i>A61N5/0622</i> (2013.01); <i>A61N 7/00</i> (2013.01); <i>A61N 7/02</i> (2013.01); <i>A61B 5/0225</i> (2013.01); <i>A61B 5/4052</i> (2013.01); <i>A61B 5/4528</i> (2013.01); <i>A61B 6/03</i> (2013.01); <i>A61B 6/506</i> (2013.01); <i>A61B 8/4245</i> (2013.01); <i>A61B 8/485</i> (2013.01); <i>A61B 19/5225</i> (2013.01); <i>A61B 2018/00404</i> (2013.01); <i>A61B 2018/00434</i> (2013.01); <i>A61B 2018/00511</i> (2013.01); <i>A61B 2019/524</i> (2013.01); <i>A61B 2019/5236</i> (2013.01); <i>A61B 2019/5276</i> (2013.01); <i>A61N 2005/063</i> (2013.01); <i>A61N 2007/003</i> (2013.01); <i>A61N 2007/0026</i> (2013.01); <i>A61N 2007/0078</i> (2013.01)	5,243,988 A	9/1993	Sieben et al.
		5,254,087 A	10/1993	McEwen
		5,263,957 A	11/1993	Davison
		5,290,278 A	3/1994	Anderson
		5,311,869 A	5/1994	Okazaki
		5,312,431 A	5/1994	McEwen
		5,352,195 A	10/1994	McEwen
		5,364,389 A	11/1994	Anderson
		5,383,896 A	1/1995	Gershony et al.
		5,391,140 A	2/1995	Schaetzle et al.
		5,391,197 A	2/1995	Burdette et al.
		5,394,877 A	3/1995	Orr et al.
		5,413,550 A	5/1995	Castel
		5,415,657 A	5/1995	Taymor-Luria
		5,439,477 A	8/1995	McEwen
		5,445,608 A	8/1995	Chen et al.
		5,453,576 A	9/1995	Krivitski
		5,454,373 A	10/1995	Koger et al.
		5,454,831 A	10/1995	McEwen
		5,471,988 A	12/1995	Fujio et al.
		5,474,071 A	12/1995	Chapelon et al.
		5,492,126 A	2/1996	Hennige et al.
		5,501,655 A	3/1996	Rolt et al.
		5,503,152 A	4/1996	Oakley et al.
		5,507,744 A	4/1996	Tay et al.
		5,507,790 A	4/1996	Weiss
		5,515,853 A	5/1996	Smith et al.
		5,520,188 A	5/1996	Hennige et al.
		5,522,878 A	6/1996	Montecalvo et al.
		5,524,620 A	6/1996	Rosenschein
		5,526,815 A	6/1996	Granz et al.
		5,534,232 A	7/1996	Denes et al.
		5,536,489 A	7/1996	Lohrmann et al.
		5,553,618 A	9/1996	Suzuki et al.
		5,556,415 A	9/1996	McEwen et al.
		5,558,092 A	9/1996	Unger et al.
		5,573,497 A	11/1996	Chapelon
		5,578,055 A	11/1996	McEwen
(56)	References Cited			
	U.S. PATENT DOCUMENTS			
	3,499,437 A	3/1970	Balamuth	
	3,552,382 A	1/1971	Mount	
	3,847,016 A	11/1974	Ziedonis	
	3,927,662 A	12/1975	Ziedonis	
	4,059,098 A	11/1977	Murdock	
	4,167,180 A	9/1979	Kossoff	
	4,197,856 A	4/1980	Northrop	
	4,206,763 A	6/1980	Pendersen	
	4,237,901 A	12/1980	Taenzer	
	4,273,127 A	6/1981	Auth et al.	
	4,469,099 A	9/1984	McEwen	
	4,479,494 A	10/1984	McEwen	
	4,484,569 A	11/1984	Driller et al.	
	4,545,386 A	10/1985	Hetz et al.	
	4,601,296 A	7/1986	Yerushalmi	
	4,605,010 A	8/1986	McEwen	
	4,688,578 A	8/1987	Takano et al.	

(56)

References Cited

U.S. PATENT DOCUMENTS

5,584,853	A	12/1996	McEwen	6,036,650	A	3/2000	Wu et al.
5,598,845	A	2/1997	Chandraratna et al.	6,037,032	A	3/2000	Klett et al.
5,601,526	A	2/1997	Chapelon et al.	6,039,694	A	3/2000	Larson et al.
5,607,447	A	3/1997	McEwen et al.	6,050,943	A	4/2000	Slayton et al.
5,609,485	A	3/1997	Bergman et al.	6,067,371	A	5/2000	Gouge et al.
5,626,601	A	5/1997	Gershony et al.	6,068,596	A	5/2000	Weth et al.
5,630,837	A	5/1997	Crowley	6,071,239	A	6/2000	Cribbs et al.
5,638,823	A	6/1997	Akay et al.	6,071,277	A	6/2000	Farley et al.
5,643,179	A	7/1997	Fujimoto	6,078,831	A	6/2000	Belef et al.
5,649,954	A	7/1997	McEwen	6,083,159	A	7/2000	Driscoll, Jr. et al.
5,655,538	A	8/1997	Lorraine et al.	6,087,761	A	7/2000	Lorraine et al.
5,657,760	A	8/1997	Ying et al.	6,102,860	A	8/2000	Mooney
5,665,073	A	9/1997	Bulow et al.	6,106,463	A	8/2000	Wilk
5,666,954	A	9/1997	Chapelon et al.	6,120,453	A	9/2000	Sharp
5,681,339	A	10/1997	McEwen et al.	6,128,522	A	10/2000	Acker et al.
5,685,307	A	11/1997	Holland et al.	6,179,831	B1	1/2001	Bliweis
5,695,493	A	12/1997	Nakajima et al.	6,182,341	B1	2/2001	Talbot et al.
5,697,897	A	12/1997	Buchholtz et al.	6,200,539	B1	3/2001	Sherman et al.
D389,574	S	1/1998	Emerson et al.	6,206,843	B1	3/2001	Iger et al.
5,711,058	A	1/1998	Frey et al.	6,213,939	B1	4/2001	McEwen
5,716,374	A	2/1998	Francese et al.	6,217,530	B1	4/2001	Martin et al.
5,720,286	A	2/1998	Chapelon et al.	6,221,015	B1	4/2001	Yock
5,720,287	A	2/1998	Chapelon et al.	6,231,507	B1	5/2001	Zikoros et al.
5,722,411	A	3/1998	Suzuki	6,233,477	B1	5/2001	Chia et al.
5,726,066	A	3/1998	Choi	6,246,156	B1	6/2001	Takeuchi et al.
5,735,796	A	4/1998	Granz et al.	6,254,601	B1	7/2001	Burbank et al.
5,738,635	A	4/1998	Chapelon et al.	6,259,945	B1	7/2001	Epstein et al.
5,741,295	A	4/1998	McEwen	6,263,551	B1	7/2001	Lorraine et al.
5,755,228	A	5/1998	Wilson et al.	6,267,734	B1	7/2001	Ishibashi et al.
5,762,066	A	6/1998	Law et al.	6,270,458	B1	8/2001	Barnea
5,769,790	A	6/1998	Watkins et al.	6,277,077	B1	8/2001	Brisken et al.
5,788,636	A	8/1998	Curley	6,315,441	B2	11/2001	King
5,807,285	A	9/1998	Vaitekunas	6,332,089	B1	12/2001	Acker et al.
5,810,007	A	9/1998	Holupka et al.	6,361,496	B1	3/2002	Zikoros et al.
5,810,810	A	9/1998	Tay et al.	6,361,548	B1	3/2002	McEwen
5,817,021	A	10/1998	Reichenberger	6,399,149	B1	6/2002	Klett et al.
5,823,962	A	10/1998	Schaetzle et al.	6,406,759	B1	6/2002	Roth
5,824,015	A	10/1998	Sawyer	6,409,720	B1	6/2002	Hissong et al.
5,824,277	A	10/1998	Campos	6,419,669	B1	7/2002	Frazier et al.
5,827,204	A	10/1998	Grandia et al.	6,425,867	B1	7/2002	Vaezy et al.
5,827,268	A	10/1998	Laufer	6,425,876	B1	7/2002	Frangi et al.
5,833,647	A	11/1998	Edwards	6,432,067	B1	8/2002	Martin et al.
5,840,028	A	11/1998	Chubachi et al.	6,443,894	B1	9/2002	Sumanaweera et al.
5,846,517	A	12/1998	Unger	6,453,526	B2	9/2002	Lorraine et al.
5,852,860	A	12/1998	Lorraine et al.	6,488,639	B1	12/2002	Ribault et al.
5,853,752	A	12/1998	Unger et al.	6,491,672	B2	12/2002	Slepian et al.
5,855,589	A	1/1999	McEwen et al.	6,494,848	B1	12/2002	Sommercorn et al.
5,873,828	A	2/1999	Fujio et al.	6,500,133	B2	12/2002	Martin et al.
5,873,845	A	2/1999	Cline et al.	6,506,171	B1	1/2003	Vitek et al.
5,879,314	A	3/1999	Peterson et al.	6,514,221	B2	2/2003	Hynynen et al.
5,882,302	A	3/1999	Driscoll, Jr. et al.	6,520,915	B1	2/2003	Lin et al.
5,882,328	A	3/1999	Levy et al.	6,522,926	B1	2/2003	Kieval et al.
5,895,356	A	4/1999	Andrus et al.	6,548,047	B1	4/2003	Unger
5,904,659	A	5/1999	Duarte et al.	6,551,576	B1	4/2003	Unger et al.
5,906,580	A	5/1999	Kline-Schoder et al.	6,559,644	B2	5/2003	Froundlich et al.
5,911,735	A	6/1999	McEwen	6,562,037	B2	5/2003	Paton et al.
5,919,139	A	7/1999	Lin	6,565,557	B1	5/2003	Sporri et al.
5,921,994	A	7/1999	Andreas et al.	6,576,168	B2	6/2003	Hardcastle et al.
5,922,945	A	7/1999	Allmaras et al.	6,584,360	B2	6/2003	Francischelli et al.
5,931,786	A	8/1999	Whitmore, III et al.	6,595,934	B1	7/2003	Hissong et al.
5,931,853	A	8/1999	McEwen	6,599,256	B1	7/2003	Acker et al.
5,935,144	A	8/1999	Estabrook	6,599,288	B2	7/2003	Maguire
5,935,146	A	8/1999	McEwen	6,602,251	B2	8/2003	Burbank et al.
5,935,339	A	8/1999	Henderson et al.	6,612,988	B2	9/2003	Maor et al.
5,938,600	A	8/1999	Van Vaals et al.	6,616,624	B1	9/2003	Kieval
5,951,476	A	9/1999	Beach	6,626,855	B1	9/2003	Weng et al.
5,957,849	A	9/1999	Munro	6,633,658	B1	10/2003	Dabney et al.
5,964,782	A	10/1999	Lafontaine et al.	6,652,461	B1	11/2003	Levkovitz
5,976,092	A	11/1999	Chinn	6,656,131	B2	12/2003	Alster et al.
5,979,453	A	11/1999	Savage et al.	6,656,136	B1	12/2003	Weng et al.
5,993,389	A	11/1999	Driscoll, Jr. et al.	6,676,601	B1	1/2004	Lacoste et al.
5,997,481	A	12/1999	Adams et al.	6,682,483	B1	1/2004	Abend et al.
6,007,499	A	12/1999	Martin et al.	6,685,639	B1	2/2004	Wang et al.
6,014,473	A	1/2000	Hossack et al.	6,706,892	B1	3/2004	Ezrin et al.
6,033,506	A	3/2000	Klett	6,709,392	B1	3/2004	Salgo et al.
				6,709,407	B2	3/2004	Fatemi
				6,716,184	B2	4/2004	Vaezy et al.
				6,719,694	B2	4/2004	Weng et al.
				6,719,699	B2	4/2004	Smith

(56)

References Cited

U.S. PATENT DOCUMENTS

6,726,627	B1	4/2004	Lizzi et al.	2004/0078034	A1	4/2004	Acker et al.
6,728,566	B1	4/2004	Subramanyan et al.	2004/0078219	A1	4/2004	Kaylor et al.
6,735,461	B2	5/2004	Vitek et al.	2004/0082978	A1	4/2004	Harrison et al.
6,755,789	B2	6/2004	Stringer et al.	2004/0097805	A1	5/2004	Verard et al.
6,764,488	B1	7/2004	Burbank et al.	2004/0097840	A1	5/2004	Holmer
6,846,291	B2	1/2005	Smith et al.	2004/0106880	A1	6/2004	Weng et al.
6,875,176	B2	4/2005	Mourad et al.	2004/0113524	A1	6/2004	Baumgartner et al.
6,875,420	B1	4/2005	Quay	2004/0122493	A1	6/2004	Ishibashi et al.
6,905,498	B2	6/2005	Hooven	2004/0127798	A1	7/2004	Dala-Krishna et al.
6,932,771	B2	8/2005	Whitmore et al.	2004/0153126	A1	8/2004	Okai
6,955,648	B2	10/2005	Mozayeni et al.	2004/0158154	A1	8/2004	Hanafy et al.
6,978,174	B2	12/2005	Gelfand et al.	2004/0220167	A1	11/2004	Samly
7,022,077	B2	4/2006	Mourad et al.	2004/0234453	A1	11/2004	Smith
7,052,463	B2	5/2006	Peszynski et al.	2004/0254620	A1	12/2004	Lacoste et al.
7,063,666	B2	6/2006	Weng et al.	2004/0267252	A1	12/2004	Washington et al.
7,128,711	B2	10/2006	Medan et al.	2005/0038339	A1	2/2005	Chauhan et al.
7,149,564	B2	12/2006	Vining et al.	2005/0038340	A1	2/2005	Vaezy et al.
7,162,303	B2	1/2007	Levin et al.	2005/0043625	A1	2/2005	Oliver et al.
7,211,060	B1	5/2007	Talish et al.	2005/0046311	A1	3/2005	Baumgartner et al.
7,260,250	B2	8/2007	Summers et al.	2005/0054955	A1	3/2005	Lidgren
7,285,093	B2	10/2007	Anisimov et al.	2005/0065436	A1	3/2005	Ho et al.
7,374,538	B2	5/2008	Nightingale et al.	2005/0070790	A1	3/2005	Niwa et al.
7,445,599	B2	11/2008	Kelly et al.	2005/0085793	A1	4/2005	Glossop
7,470,241	B2	12/2008	Weng et al.	2005/0090104	A1	4/2005	Yang et al.
7,499,748	B2	3/2009	Moffitt et al.	2005/0096538	A1	5/2005	Chomas et al.
7,510,536	B2	3/2009	Foley et al.	2005/0096542	A1	5/2005	Weng et al.
7,530,958	B2	5/2009	Slayton et al.	2005/0119704	A1	6/2005	Peters et al.
7,534,209	B2	5/2009	Abend	2005/0149126	A1	7/2005	Libbus
7,553,284	B2	6/2009	Vaitekunas	2005/0154299	A1	7/2005	Hocor et al.
7,617,005	B2	11/2009	Demarais et al.	2005/0165298	A1	7/2005	Larson et al.
7,620,451	B2	11/2009	Demarais et al.	2005/0182297	A1	8/2005	Gravenstein et al.
7,628,764	B2	12/2009	Duarte et al.	2005/0182319	A1	8/2005	Glossop
7,684,865	B2	3/2010	Aldrich et al.	2005/0192638	A1	9/2005	Gelfand et al.
7,697,972	B2	4/2010	Verard et al.	2005/0240102	A1	10/2005	Rachlin et al.
7,698,947	B2	4/2010	Sarr	2005/0240103	A1	10/2005	Byrd et al.
7,766,833	B2	8/2010	Lee	2005/0240126	A1	10/2005	Foley et al.
7,783,358	B2	8/2010	Aldrich et al.	2005/0240127	A1	10/2005	Seip et al.
8,295,912	B2	10/2012	Gertner	2005/0240170	A1	10/2005	Zhang et al.
8,347,891	B2	1/2013	Demarais et al.	2005/0240241	A1	10/2005	Yun et al.
8,383,671	B1	2/2013	Consigny	2005/0261672	A1	11/2005	Deem et al.
8,556,834	B2	10/2013	Gertner	2005/0277853	A1	12/2005	Mast et al.
8,715,209	B2	5/2014	Gertner	2005/0288730	A1	12/2005	Deem et al.
2001/0014775	A1	8/2001	Koger et al.	2006/0004417	A1	1/2006	Rossing
2001/0014805	A1	8/2001	Burbank et al.	2006/0025756	A1	2/2006	Francischelli et al.
2001/0032382	A1	10/2001	Lorraine et al.	2006/0052701	A1	3/2006	Carter et al.
2001/0041910	A1	11/2001	McEwen	2006/0058678	A1	3/2006	Vitek et al.
2001/0044636	A1	11/2001	Pedros et al.	2006/0058707	A1	3/2006	Barthe et al.
2002/0055736	A1	5/2002	Horn et al.	2006/0082771	A1	4/2006	Doerrmann et al.
2002/0072672	A1	6/2002	Roundhill et al.	2006/0084966	A1	4/2006	Maguire et al.
2002/0095164	A1	7/2002	Andreas et al.	2006/0122514	A1	6/2006	Byrd et al.
2002/0193831	A1	12/2002	Smith, III	2006/0184069	A1	8/2006	Vaitekunas
2003/0009194	A1	1/2003	Saker et al.	2006/0235300	A1	10/2006	Weng et al.
2003/0018255	A1	1/2003	Martin et al.	2006/0235303	A1	10/2006	Vaezy et al.
2003/0036771	A1	2/2003	McEwen	2006/0293712	A1	12/2006	Kieval et al.
2003/0050665	A1	3/2003	Ginn	2007/0004984	A1	1/2007	Crum et al.
2003/0060737	A1	3/2003	Briskin	2007/0016274	A1	1/2007	Boveja et al.
2003/0069569	A1	4/2003	Burdette et al.	2007/0038115	A1	2/2007	Quigley et al.
2003/0114756	A1	6/2003	Li	2007/0055155	A1	3/2007	Owen et al.
2003/0120204	A1	6/2003	Unger et al.	2007/0055181	A1	3/2007	Deem et al.
2003/0149366	A1	8/2003	Stringer et al.	2007/0066957	A1	3/2007	Demarais et al.
2003/0153849	A1	8/2003	Huckle et al.	2007/0106339	A1	5/2007	Errico et al.
2003/0187371	A1	10/2003	Vortman et al.	2007/0112327	A1	5/2007	Yun et al.
2003/0195420	A1	10/2003	Mendlein et al.	2007/0129720	A1	6/2007	Demarais et al.
2003/0208101	A1	11/2003	Cecchi	2007/0129761	A1	6/2007	Demarais et al.
2003/0216792	A1	11/2003	Levin et al.	2007/0135875	A1	6/2007	Demarais et al.
2003/0225331	A1	12/2003	Diederich et al.	2007/0142879	A1	6/2007	Greenberg et al.
2004/0002654	A1	1/2004	Davidson et al.	2007/0149880	A1	6/2007	Willis
2004/0030227	A1	2/2004	Littrup et al.	2007/0167806	A1	7/2007	Wood et al.
2004/0030268	A1	2/2004	Weng et al.	2007/0179379	A1	8/2007	Weng et al.
2004/0030269	A1	2/2004	Horn et al.	2007/0203527	A1	8/2007	Ben-David et al.
2004/0039280	A1	2/2004	Wu et al.	2007/0213616	A1	9/2007	Anderson et al.
2004/0049105	A1	3/2004	Crutchfield et al.	2007/0233185	A1	10/2007	Anderson et al.
2004/0054287	A1	3/2004	Stephens	2007/0239000	A1	10/2007	Emery et al.
2004/0054289	A1	3/2004	Eberle et al.	2007/0265687	A1	11/2007	Deem et al.
2004/0071664	A1	4/2004	McHale et al.	2007/0282407	A1	12/2007	Demarais et al.
				2008/0033292	A1	2/2008	Shafraan
				2008/0033420	A1	2/2008	Nields et al.
				2008/0039746	A1	2/2008	Hissong et al.
				2008/0045864	A1	2/2008	Candy et al.

(56)

References Cited

U.S. PATENT DOCUMENTS

2008/0045865 A1 2/2008 Kislev
 2008/0046016 A1 2/2008 Ben-David
 2008/0047325 A1 2/2008 Bartlett
 2008/0051767 A1 2/2008 Rossing et al.
 2008/0058683 A1 3/2008 Gifford et al.
 2008/0194954 A1 8/2008 Unger et al.
 2008/0200806 A1 8/2008 Liu et al.
 2008/0200815 A1 8/2008 Van Der Steen et al.
 2008/0234569 A1 9/2008 Tidhar et al.
 2008/0255498 A1 10/2008 Houle
 2008/0255642 A1 10/2008 Zarins et al.
 2008/0288017 A1 11/2008 Kieval
 2008/0312561 A1 12/2008 Chauhan
 2008/0312562 A1 12/2008 Routh et al.
 2008/0317204 A1 12/2008 Sumanaweera et al.
 2008/0319375 A1 12/2008 Hardy
 2009/0012098 A1 1/2009 Jordan et al.
 2009/0036948 A1 2/2009 Levin et al.
 2009/0054770 A1 2/2009 Daigle
 2009/0062697 A1 3/2009 Zhang et al.
 2009/0062873 A1 3/2009 Wu et al.
 2009/0076409 A1 3/2009 Wu et al.
 2009/0088623 A1 4/2009 Vortman et al.
 2009/0112095 A1 4/2009 Daigle
 2009/0112133 A1 4/2009 Deisseroth et al.
 2009/0149782 A1 6/2009 Cohen et al.
 2009/0163982 A1 6/2009 Decharms
 2009/0221908 A1 9/2009 Glossop
 2009/0221939 A1 9/2009 Demarais et al.
 2009/0247911 A1 10/2009 Novak et al.
 2009/0264755 A1 10/2009 Chen et al.
 2009/0306644 A1 12/2009 Maysse et al.
 2010/0010393 A1 1/2010 Duffy et al.
 2010/0022921 A1 1/2010 Seip et al.
 2010/0023088 A1 1/2010 Stack et al.
 2010/0042020 A1 2/2010 Ben-Ezra
 2010/0081971 A1 4/2010 Allison
 2010/0092424 A1 4/2010 Sanghvi et al.
 2010/0125269 A1 5/2010 Emmons et al.
 2010/0160781 A1 6/2010 Carter et al.
 2010/0174188 A1 7/2010 Wang et al.
 2011/0021913 A1 1/2011 Weng et al.
 2011/0028867 A1 2/2011 Choo et al.
 2011/0092781 A1 4/2011 Gertner
 2011/0112400 A1 5/2011 Emery et al.
 2011/0124976 A1 5/2011 Sabczynski et al.
 2011/0251489 A1 10/2011 Zhang et al.
 2011/0257561 A1 10/2011 Gertner et al.
 2012/0065492 A1 3/2012 Gertner et al.
 2012/0109018 A1 5/2012 Gertner et al.
 2012/0123243 A1 5/2012 Hastings

FOREIGN PATENT DOCUMENTS

EP 0679371 A1 11/1995
 EP 1265223 A2 12/2002
 EP 1579889 9/2005
 EP 1847294 A1 10/2007
 JP H05-220152 8/1993
 JP 2007000218 1/2007
 WO WO 9502361 1/1995
 WO WO 9731364 A1 8/1997
 WO WO 9948621 A2 9/1999
 WO WO 0134018 A2 5/2001
 WO WO 02069805 A2 9/2002
 WO WO 2005030295 A2 4/2005
 WO WO 2006003606 1/2006
 WO WO 2006121447 A2 11/2006
 WO WO 2006129099 12/2006
 WO WO 2008144274 11/2008
 WO WO 2009003138 12/2008
 WO WO 2009018351 2/2009
 WO WO 2009018394 A1 2/2009

WO WO 2009081339 7/2009
 WO WO 2011053757 A1 5/2011
 WO WO 2011053772 A1 5/2011

OTHER PUBLICATIONS

Amenta et al., "A New Voronoi-Based Surface Reconstruction Algorithm." *Computer Graphics*: 7pp, 1998.
 American Red Cross., "Blood 101." 4pp., Dec. 11, 2007.
 Anand et al., "Monitoring formation of high intensity focused ultrasound (HIFU) induced lesions using backscattered ultrasound." *Acoustical Society of America*; Mar. 10, 2004.
 Anand et al., "Using the ATL 1000 to Collect Demodulated RF Data for Monitoring HIFU Lesion Formation." *Presented at SPIE Medical Imaging 2003*. 11pp, 2003.
 Aurenhammer, F. "Voronoi diagrams—A Survey of a Fundamental Geometric Data Structure." *ACM Computing Surveys*, vol. 23, No. 3: 345-405, Sep. 1991.
 Bachmann, et al. "Targeting Mucosal Addressin Cellular Adhesion Molecule (MAdCAM)-1 to Noninvasively Image Experimental Crohn's Disease." *Gastroenterology* 2006; 130: 8-16.
 Barthe et al. "Efficient Wideband Linear Arrays for Imaging and Therapy" *IEEE Ultrasonics Symposium*. pp. 1249-1252 (1999).
 Bauer et al., "Ultrasound Imaging with SonoVue: Low Mechanical Index Real-Time Imaging." *Acad. Radiol.*; vol. 9, Suppl. 2: S282-S284, 2002.
 Beard et al., "An Annular Focus Ultrasonic Lens for Local Hyperthermia Treatment of Small Tumors." *Ultrasound in Medicine & Biology*; vol. 8, No. 2: 177-184, 1982.
 Bokarewa et al., "Tissue factor as a proinflammatory agent." *Arthritis Research*, vol. 4: 190-195, Jan. 10, 2002.
 Bots et al., "Intima Media Thickness as a Surrogate Marker for Generalised Atherosclerosis." *Cardiovascular Drugs and Therapy*, ProQuest Medical Library; vol. 16, No. 4: 341-351, Jul. 2002.
 Brayman et al., "Erosion of Artificial Endothelia In Vitro by Pulsed Ultrasound: Acoustic Pressure, Frequency, Membrane Orientation and Microbubble Contrast Agent Dependence." *Ultrasound in Medicine & Biology*; vol. 25, No. 8: 1305-1320, 1999.
 Buller et al., "Accurate Three-dimensional Wall Thickness Measurement From Multi-Slice Short-Axis MR Imaging." *Computers in Cardiology*, 245-248, 1995.
 Byram et al., "3-D Phantom and In Vivo Cardiac Speckle Tracking Using a Matrix Array and Raw Echo Data." *IEEE Transactions on Ultrasonics, Ferroelectrics, and Frequency Control*, vol. 57, No. 4: 839-854, Apr. 2010.
 Campese, V., Krol, E. Neurogenic Factors in Renal Hypertension. *Current Hypertension Reports* 2002, 4:256-260.
 Canadian Examination Report dated Nov. 14, 2007 in CA Patent Application 2,387,127, filed Oct. 25, 2000.
 Chao et al., "Aspheric lens design." *Ultrasonics Symposium, 2000 IEEE*, vol. 2: Abstract Only, Oct. 2000.
 Chelule, K. et al., Fabrication of medical models from scan data via rapid prototyping techniques, Proceedings of the 2000 Conference on Time Compression Technologies, Cardiff International Arena, UK; 2000.
 Chen et al., "A comparison of the fragmentation thresholds and inertial cavitation doses of different ultrasound contrast agents." *Journal of the Acoustical Society of America*, vol. 113, No. 1: 643-665, Jan. 2003.
 Chen et al., "Inertial Cavitation Dose and Hemolysis Produced In Vitro With or Without Optison." *Ultrasound in Medicine & Biology*, vol. 29, No. 5: 725-737, 2003.
 Chong et al., "Tissue Factor and Thrombin Mediate Myocardial Ischemia-Reperfusion Injury." *The Society of Thoracic Surgeons*, vol. 75: S649-655, 2003.
 Dayton et al., "The magnitude of radiation force on ultrasound contrast agents." *Journal of the Acoustical Society of America*, vol. 112, No. 5, Part 1: 2183-2192, Nov. 2002.
 Dempsey et al., "Thickness of Carotid Artery Atherosclerotic Plaque and Ischemic Risk." *Neurosurgery*, vol. 27, No. 3: 343-348, 1990.
 Dibona, G. F., "Neural control of the kidney: functionally specific renal sympathetic nerve fibers." *Am J Physiol Regulatory Integrative Comp Physiol*. pp. 1517-1524, 2000.

(56)

References Cited

OTHER PUBLICATIONS

- Dibona, G. F., et al., Chaotic behavior of renal sympathetic nerve activity: effect of baroreceptor denervation and cardiac failure, *Am J Physiol Renal Physiol*, 279:F491-501, 2000.
- Dibona, GF. Functionally Specific Renal Sympathetic Nerve Fibers: Role in Cardiovascular Regulation. *American Journal of Hypertension*. 2001 vol. 14(6) 163S-170S.
- Doumas, M., et al., Renal Sympathetic Denervation: The Jury is Still Out, *The Lancet*, Nov. 2010, vol. 376, Issue 9756, pp. 1878-1880.
- Ebbini et al., "Image-guided noninvasive surgery with ultrasound phased arrays." *SPIE*, vol. 3249: 230-239, Apr. 2, 1998.
- Edelsbrunner, Herbert. "Geometry and Topology for Mesh Generation." *Cambridge University Press*: 68pp, 2001.
- Esler, et al., "Renal sympathetic denervation in patients with treatment-resistant hypertension (The Symplicity HTN-2 Trials): a randomised controlled trial." *The Lancet*: vol. 376, Issue 9756, pp. 1903-1909. Dec. 4, 2010.
- European Examination Report dated Mar. 7, 2008 in EP Patent Application 989717.4, filed Oct. 25, 2000.
- Everbach et al., "Cavitational Mechanisms in Ultrasound-Accelerated Thrombolysis at 1 MHz." *Ultrasound in Medicine & Biology*, vol. 26, No. 7: 1153-1160, 2000.
- Ewert, et al. "Anti-myeloperoxidase antibodies stimulate neutrophils to damage human endothelial cells." *Kidney International*, vol. 4, pp. 375-383. 1992.
- Fjfield, T., et al., A parametric study of the concentric-ring transducer design for MRI guided ultrasound surgery, *J. Acoust. Soc. Am.* vol. 100, Issue 2, pp. 1220-1230 (1996); (11 pages).
- Ganapathy et al., "A New General Triangulation Method for Planar Contours." *Computer Graphics* vol. 16, No. 3:69-75, 1982.
- Grassi, G. "Role of the sympathetic nervous system in human hypertension." *Journals of Hypertension* 1998, vol. 16. No. 12.
- Gray, Henry. "The Skull." *Anatomy of the Human Body*: 7pp., 1918.
- Guzman et al., "Ultrasound-Mediated Disruption of Cell Membranes. I. Quantification of Molecular uptake and Cell Viability. / II. Heterogeneous effects on cells." *Journal of the Acoustical Society of America*, vol. 110, No. 1: 588-606, Jul. 2001.
- Hachimine, et al. "Sonoynamic therapy of cancer using a novel porphyrin derivative, DCPH-P-Na(I), which is devoid of photosensitivity." *Japanese Cancer Association* pp. 916-920. Apr. 4, 2007.
- Hadimioglu et al., "High-Efficiency Fresnel Acoustic Lenses." *Ultrasonics Symposium 1993 IEEE*: 579-582, 1993.
- Han et al., "A Fast Minimal Path Active Contour Model." *IEEE Transactions on Image Processing*, vol. 10, No. 6: 865-873, Jun. 2001.
- Hatangadi, Ram. "A Novel Dual Axis Multiplanar Transesophageal Ultrasound Probe for Three-Dimensional Echocardiograph." *University of Washington, Department of Sciences and Engineering*, vol. 55-11B: Abstract 1pg, 1994.
- Holt et al., "Bubbles and Hifu: the Good, the Bad and the Ugly." *Boston University, Department of Aerospace and Mechanical Engineering*: 120-131, 2002.
- Hubka et al., "Three-dimensional echocardiographic measurement of left ventricular wall thickness: In vitro and in vivo validation." *Journal of the American Society of Echocardiography*, vol. 15, No. 2: 129-135, 2002.
- Hutchinson et al. "Intracavitary Ultrasound Phased Arrays for Noninvasive Prostate Surgery." *IEEE Transactions on Ultrasonics, Ferroelectrics, and Frequency Control*. 43(6):1032-1042 (1996).
- Hwang et al., "Vascular Effects Induced by Combined 1-MHz Ultrasound and Microbubble Contrast Agent Treatments In Vivo." *Ultrasound in Medicine & Biology*, vol. 31, No. 4: 553-564, 2005.
- Hynynen et al., "Potential Adverse Effects of High-Intensity Focused Ultrasound Exposure on Blood Vessels In Vivo." *Ultrasound in Medicine & Biology*, vol. 22, No. 2: 193-201, 1996.
- Iannuzzi, et al. "Ultrasonographic Correlates of Carotid Atherosclerosis in Transient Ischemic Attack and Stroke." *The American Heart Association*. 1995; 26: 614-619.
- Idell et al., "Fibrin Turnover in Lung Inflammation and Neoplasia." *American Journal of Respiratory and Critical Care Medicine*, vol. 163: 578-584, 2001.
- Indman, P. "Advanced Gynecology Solutions." Dec. 10, 2010. <<http://www.gynalternatives.com/hsc.htm>>.
- International Search Report and Written Opinion dated Dec. 6, 2010 for PCT Application No. PCT/US2010/052193.
- International Search Report and Written Opinion dated Jun. 6, 2011 for PCT/US2010/052197.
- International Search Report and Written Opinion dated May 18, 2001 in PCT/US2000/041606.
- Janssen, et al. "Renal Nerves in Hypertension." S.Karger AG, Basel, 1989.
- Jolesz, F. MRI-Guided Focused Ultrasound Surgery. *Annual Review of Medicine*. 2009 60: 417-30.
- Kaczkowski et al., "Development of a High Intensity Focused Ultrasound System for Image-Guided Ultrasonic Surgery." *Ultrasound for Surgery*, 2001. <<http://cimu.apl.washington.edu/hifusurgerysystem.html>>.
- Kang et al., "Analysis of the Measurement Precision of Arterial Lumen and Wall Areas Using High-Resolution MRI." *Magnetic Resonance in Medicine*, vol. 44: 968-972, 2000.
- Klibanov et al., "Detection of Individual Microbubbles of an Ultrasound contrast Agent: Fundamental and Pulse Inversion Imaging." *Academy of Radiology*, vol. 9, Suppl. 2: S279-S281, 2002.
- Kojima, T., Matrix Array Transducer and Flexible Matrix Array Transducer, Proceedings of the Ultrasonics Symposium, vol. 2:649-653 (1986).
- Krum, et al. "Pharmacologic Mangement of the Cardiorenal Syndrome in Heart Failure." *Current heart Failure Reports* pp. 105-111, 2009.
- Krum, H et al., "Catheter-Based Renal Sympathetic Denervation for Resistant Hypertension: a Multicentre Safety and Proof-of-Principle Cohort Study," *Lancet* 2009 373; 1275-1281.
- Kudo et al., "Study on Mechanism of Cell Damage Caused by Microbubbles Exposed to Ultrasound." *Ultrasound in Medicine & Biology*, vol. 29, Supplement: 4pp, 2003.
- Lalonde et al., "Field conjugate acoustic lenses for ultrasound hyperthermia." *Ultrasonics, Ferroelectrics and Frequency Control, IEEE Transactions*, vol. 40, Issue 5: Abstract 1 pg., Sep. 1993.
- Martin et al., Hemostasis of Punctured Vessels Using Doppler-Guided High Intensity Ultrasound, *Ultrasound in Med. & Biol.*, vol. 25, pp. 985-990, 1999, USA.
- Mde et al., Renal sympathetic denervation in patients with treatment resistant hypertension (The Symplicity HTN-2 Trial): a randomised controlled trial, Nov. 2010, *The Lancet*, vol. 376, Issue 9756, pp. 1903-1909.
- Meyers, D. "Multiresolution tiling." *Computer Graphics*, No. 5: 325-340, 1994.
- Miller et al., "A Review of In Vitro Bioeffects of Inertial Ultrasonic Cavitation From a Mechanistic Perspective." *Ultrasound in Medicine & Biology*, vol. 22, No. 9: 1131-1154, 1996.
- Miller, et al. "Diagnostic ultrasound activation of contrast agent gas bodies induces capillary rupture in mice." *National Academy of Sciences*, vol. 97, No. 18: 10179-10184, 2000.
- Moss, N. G. Renal Function and Renal Afferent and Efferent Nerve Activity. *American Journal Physiology*. 243 (Renal Fluid Electrolyte Physiology) 12: F425-F433, 1982.
- N.a., "Breast Cancer—Insightec: focused ultrasound for non invasive treatment." FAQ, 2000. <http://www.exablate2000.com/physicians_faq.html>.
- N.a., "Cavitation." *Ultrasound TIP—U.S. Database*: Dec. 12, 2007.
- N.a., "Mechanical Bioeffects in the Presence of Gas-Carrier Ultrasound Contrast Agents." *Journal of Ultrasound & Medicine*, vol. 19: 120-142, 2000.
- Ng et al., "Therapeutic Ultrasound: Its Application in Drug Delivery." *Medicinal Research Reviews*, vol. 22, No. 2: 204-233, 2002.
- Notice of Allowance dated Mar. 25, 2003 from U.S. Appl. No. 09/696,076, filed Oct. 25, 2000.
- Office Action dated Aug. 17, 2006 from U.S. Appl. No. 10/671,417, filed Sep. 24, 2003.
- Office Action dated Jul. 31, 2007 from U.S. Appl. No. 10/671,417, filed Sep. 24, 2003.

(56)

References Cited

OTHER PUBLICATIONS

- Office Action dated Jul. 5, 2006 from U.S. Appl. No. 10/616,831, filed Jul. 10, 2003.
- Office Action dated Nov. 29, 2002 from U.S. Appl. No. 09/696,076, filed Oct. 25, 2000.
- O'Leary, et al., "Carotid-Artery Intima and Media Thickness as a Risk Factor for Myocardial Infarction and Stroke in Older Adults." Cardiovascular Health Study Collaborative Research Group. *New England Journal of Medicine*, vol. 340, No. 1: 14-22, Jan. 7, 1999.
- Ostensen et al., "Characterization and Use of Ultrasound Contrast Agents." *Academy of Radiology*, vol. 9, Suppl. 2: S276-S278, 2002.
- Owaki et al., "The Ultrasonic Coagulating and Cutting System Injuries Nerve Function." *Endoscopy*, vol. 34, No. 7: 575-579, 2002.
- Pignoli, P., et al., "Intimal plus medial thickness of the arterial wall: a direct measurement with ultrasound imaging, *Circulation* 1986;74:1399-1406.
- Poliachik et al., "Activation, Aggregation and Adhesion of Platelets Exposed to High-Intensity Focused Ultrasound." *Ultrasound in Medicine & Biology*, vol. 27, No. 11: 1567-1576, 2001.
- Poliachik et al., "Effect of High-Intensity Focused Ultrasound on Whole Blood With or Without Microbubble Contrast Agent." *Ultrasound in Medicine & Biology*, vol. 25, No. 6: 991-998, 1999.
- Porter et al., "Ultrasound, Microbubbles and Thrombolysis." *Progress in Cardiovascular Diseases*, vol. 44, No. 2: 101-110, Oct. 2001.
- Rivens et al., "Vascular Occlusion Using Focused Ultrasound Surgery for Use in Fetal Medicine." *European Journal of Ultrasound*, vol. 9: 89-97, 1999.
- Rosen et al., "Vascular Occlusive Diseases." 37pp., revised 2002.
- Rosenschein et al., "Shock-Wave Thrombus Ablation, A New Method for Noninvasive Mechanical Thrombolysis." *The American Journal of Cardiology*, vol. 70, Issue 15: Abstract, Nov. 15, 1992.
- Rosenschein, U., et al., "Ultrasound Imaging-Guided Noninvasive Ultrasound Thrombolysis : Preclinical Results, *Circulation*, 2000;102:238-245.
- Sanghvi et al. "High-Intensity Focused Ultrasounds." *Experimental and Investigational Endoscopy*. 4(2):383-395 (1994).
- Schlaich, et al. "Sympathetic Activation in Chronic Renal Failure." *J Am Soc Nephrol*. pp. 933-939, 2009.
- Schulte-Altendorneburg, et al. "Accuracy of In Vivo Carotid B-Mode Ultrasound Compared with Pathological Analysis: Intima-Media Thickening, Lumen Diameter, and Cross-Sectional Area." *American Stroke Association*, vol. 32, No. 7: 1520-1524, 2001.
- Tachibana et al. "Albumin Microbubble Echo-Contrast Material as Enhancer for Ultrasound Accelerated Thrombolysis." *American Heart Association*. vol. 92: 1148-1150, 1995.
- Tachibana et al., "The Use of Ultrasound for Drug Delivery." *Echocardiography*, vol. 18, No. 4: 323-328, May 2001.
- Tardy et al., "In Vivo Ultrasound Imaging of Thrombi Using a Target-specific Contrast Agent." *Academy of Radiology*, vol. 9, Suppl. 2: S294-S296, 2002.
- ter Haar, G. Ultrasound Focal Beam Surgery. *Ultrasound in Medicine and Biology*. 21(9):1089-1100 (1995).
- Vaezy et al., "Acoustic surgery." *Physics World*: 35-39, Aug. 2001.
- Vaezy et al., "Hemostasis and Tumor Treatment using High Intensity Focused Ultrasound: Experimental Investigations and Device Development." *First International Workshop on the Application of HIFU in Medicine*: 46-49, 2001.
- Vaezy et al., "Hemostasis using high intensity focused ultrasound." *European Journal of Ultrasound*, vol. 9: 79-87, 1999.
- Vaezy et al., "Intra-operative acoustic hemostasis of liver: production of a homogenate for effective treatment." *Ultrasonics*, vol. 43: 265-269, 2005.
- Vaezy, S. et al., Hemostasis of Punctured Blood Vessels Using High-Intensity Focused Ultrasound, *Ultrasound in Medicine and Biology*, 1998, vol. 24; No. 6, pp. 903-910.
- Valente, et al. "Laparoscopic renal denervation for intractable ADPKD-related pain." *Nephrol Dial Transplant*. pp. 160. 2001.
- Von Land et al., "Development of an Improved Centreline Wall Motion Model." *IEEE*: 687-690, 1991.
- Watkin et al., "Multi-Modal Contrast Agents: A First Step." *Academy of Radiology*, vol. 9, Suppl. 2: S285-S287, 2002.
- Wickline et al., "Blood Contrast Enhancement with a Novel, Non-Gaseous Nanoparticle Contrast Agent." *Academy of Radiology*, vol. 9, Suppl. 2: S290-S293, 2002.
- Williamson et al., "Color Doppler Ultrasound Imaging of the Eye and Orbit." *Survey of Ophthalmology*, vol. 40, No. 4: 255-267, 1996.
- Yu et al., "A microbubble agent improves the therapeutic efficiency of high intensity focused ultrasound: a rabbit kidney study." *Urological Research*, PubMed: Abstract, 2004.
- Non-Final Office Action dated Apr. 6, 2012 for U.S. Appl. No. 12/685,655.
- Non-Final Office Action dated Nov. 28, 2011 for U.S. Appl. No. 13/246,763.
- International Search Report and Written Opinion dated Jul. 27, 2011 for PCT/US2011/033337.
- European Search Report & Search Opinion dated Nov. 25, 2011 for European Application No. 10810835.8.
- Non-Final Office Action dated Apr. 10, 2012 for U.S. Appl. No. 12/725,450.
- Non-Final Office Action dated Mar. 20, 2012 for U.S. Appl. No. 13/246,775.
- International Preliminary Report on Patentability dated Apr. 17, 2012 for PCT Appln. No. PCT/US10/52193.
- International Preliminary Report on Patentability dated Apr. 17, 2012 for PCT Appln. No. PCT/US10/52197.
- Final Office Action dated Apr. 25, 2012 for U.S. Appl. No. 13/246,763.
- Advisory Action dated Aug. 15, 2012 for U.S. Appl. No. 12/725,450.
- European Examination Report dated Oct. 22, 2012 for EP Appln. No. 10810835.8.
- Extended European Search Report dated Oct. 22, 2012 for European Appln. No. 10823909.6.
- Notice of Allowance dated Nov. 9, 2012 for U.S. Appl. No. 13/019,273.
- Final Office Action dated Dec. 4, 2012 for U.S. Appl. No. 13/487,135.
- Final Office Action dated Dec. 5, 2012 for U.S. Appl. No. 12/966,943.
- European Search Report & Search Opinion dated Dec. 7, 2012 for European Application No. 11758075.3.
- Final Office Action dated Dec. 10, 2012 for U.S. Appl. No. 12/966,962.
- Advisory Action dated Dec. 28, 2012 for U.S. Appl. No. 13/246,775.
- Non-Final Office Action dated Jan. 2, 2013 for U.S. Appl. No. 13/545,944.
- Final Office Action dated Jan. 15, 2013 for U.S. Appl. No. 13/487,121.
- Final Office Action dated Jan. 17, 2013 for U.S. Appl. No. 13/487,118.
- Final Office Action dated Jan. 29, 2013 for U.S. Appl. No. 13/048,837.
- Final Office Action dated Jan. 31, 2013 for U.S. Appl. No. 13/535,070.
- Final Office Action dated Feb. 1, 2013 for U.S. Appl. No. 13/523,835.
- Final Office Action dated Feb. 15, 2013 for U.S. Appl. No. 13/445,903.
- Final Office Action dated Feb. 15, 2013 for U.S. Appl. No. 13/048,830.
- Advisory Action dated Feb. 25, 2013 for U.S. Appl. No. 13/487,135.
- Final Office Action dated Feb. 25, 2013 for U.S. Appl. No. 13/048,842.
- Final Office Action dated Mar. 14, 2013 for U.S. Appl. No. 13/091,116.
- Final Office Action dated Mar. 15, 2013 for U.S. Appl. No. 13/111,837.
- Advisory Action dated Apr. 11, 2013 for U.S. Appl. No. 13/048,837.
- Non-Final Office Action dated Apr. 15, 2013 for U.S. Appl. No. 13/246,775.
- Final Office Action dated Apr. 19, 2013 for U.S. 2013 for U.S. Appl. No. 13/545,944.
- Notice of Allowance dated Apr. 29, 2013 for U.S. Appl. No. 13/048,830.

(56)

References Cited

OTHER PUBLICATIONS

- Final Office Action dated Apr. 29, 2013 for U.S. Appl. No. 13/048,844.
- Notice of Allowance dated Apr. 30, 2013 for U.S. Appl. No. 13/048,842.
- Notice of Allowance dated May 15, 2013 for U.S. Appl. No. 13/535,070.
- Advisory Action dated Jun. 18, 2013 for U.S. Appl. No. 12/902,133.
- Advisory Action dated Jun. 18, 2013 for U.S. Appl. No. 13/523,835.
- Notice of Allowance dated Jun. 24, 2013 for U.S. Appl. No. 12/966,962.
- M. William Apoutou N'djin: "Transducteur torique a Ultrasons Focalises de Haute Intensite pour generer des ablations volumineuses", Dec. 17, 2008, XP055009820, URL: <http://u556.lyon.inserm.fr/theses/pdf/ndjin.pdf>.
- Foreign Office Action dated Jun. 24, 2013 for EP Appln. No. 10823909.6.
- European Examination Report dated Jun. 24, 2013 for EP Appln. No. 10810835.8.
- Final Office Action dated Jul. 1, 2013 for U.S. Appl. No. 13/246,763.
- Final Office Action dated Jun. 6, 2012 for U.S. Appl. No. 12/725,450.
- Non-Final Office Action dated Jun. 8, 2012 for U.S. Appl. No. 13/019,273.
- Non-Final Office Action dated Jun. 18, 2012 for U.S. Appl. No. 12/966,954.
- Non-Final Office Action dated Jun. 18, 2012 for U.S. Appl. No. 12/966,962.
- Final Office Action dated Jun. 26, 2012 for U.S. Appl. No. 12/685,655.
- Advisory Action dated Jun. 29, 2012 for U.S. Appl. No. 13/246,763.
- Non-Final Office Action dated Jun. 22, 2012 for U.S. Appl. No. 12/966,943.
- Non-Final Office Action dated Jul. 3, 2012 for U.S. Appl. No. 12/902,133.
- Advisory Action dated Jul. 9, 2012 for U.S. Appl. No. 12/685,655.
- Non-Final Office Action dated Jul. 27, 2012 for U.S. Appl. No. 13/487,135.
- Non-Final Office Action dated Jul. 30, 2012 for U.S. Appl. No. 13/445,903.
- Notice of Allowance dated Aug. 27, 2012 for U.S. Appl. No. 12/685,655.
- Final Office Action dated Aug. 29, 2012 for U.S. Appl. No. 12/966,954.
- Non-Final Office Action dated Aug. 29, 2012 for U.S. Appl. No. 13/487,118.
- Non-Final Office Action dated Aug. 29, 2012 for U.S. Appl. No. 13/487,121.
- Non-Final Office Action dated Sep. 7, 2012 for U.S. Appl. No. 13/048,837.
- Non-Final Office Action dated Sep. 10, 2012 for U.S. Appl. No. 13/523,835.
- Non-Final Office Action dated Sep. 21, 2012 for U.S. Appl. No. 13/535,070.
- Non-Final Office Action dated Sep. 24, 2012 for U.S. Appl. No. 13/048,830.
- Non-Final Office Action dated Sep. 24, 2012 for U.S. Appl. No. 13/246,763.
- Non-Final Office Action dated Sep. 25, 2012 for U.S. Appl. No. 13/111,837.
- Non-Final Office Action dated Oct. 4, 2012 for U.S. Appl. No. 13/091,116.
- Non-Final Office Action dated Oct. 10, 2012 for U.S. Appl. No. 13/048,844.
- Non-Final Office Action dated Oct. 15, 2012 for U.S. Appl. No. 13/048,842.
- Final Office Action dated Oct. 16, 2012 for U.S. Appl. No. 13/246,775.
- Final Office Action dated Oct. 23, 2012 for U.S. Appl. No. 13/019,273.
- Advisory Action dated Jul. 25, 2013 for U.S. Appl. No. 13/545,944.
- Advisory Action dated Aug. 15, 2013 for U.S. Appl. No. 13/048,844.
- Non-Final Office Action dated Aug. 20, 2013 for U.S. Appl. No. 13/545,944.
- Office Action dated Aug. 20, 2013 for Russian Appln. No. 2012119540.
- Advisory Action dated Sep. 3, 2013 for U.S. Appl. No. 13/111,837.
- Notice of Allowance dated Sep. 13, 2013 for U.S. Appl. No. 13/111,837.
- Notice of Allowance dated Oct. 8, 2013 for U.S. Appl. No. 13/523,835.
- Non-Final Office Action dated Oct. 10, 2013 for U.S. Appl. No. 13/657,725.
- International Search Report and Written Opinion dated Nov. 26, 2013 for PCT Appln. No. PCT/US2013/057624.
- "The Journal of Allergy and Clinical Immunology" vol. 63, No. 3, 1979.
- Bouthier et al. 1985 J. Cardiovasc. Pharmacol. 7:S99-S104.
- Chen, Jie, and T. R. Gururaja. "DC-biased electrostrictive materials and transducers for medical imaging." Ultrasonics Symposium, 1997. Proceedings., 1997 IEEE. vol. 2. IEEE, 1997.
- Damianou, C., K. Hynynen, and X. Fan. "Application of the thermal dose concept for predicting the necrosed tissue volume during ultrasound surgery." Ultrasonics Symposium, 1993. Proceedings., IEEE 1993. IEEE, 1993.
- Dewhirst et al., "Basic principles of thermal dosimetry and thermal threshold for tissue damage from hyperthermia" 2003.
- Notice of Allowance dated Jan. 14, 2014 for U.S. Appl. No. 13/445,903.
- Final Office Action dated Jul. 16, 2015 for U.S. 2013 for U.S. Appl. No. 13/545,944.
- Final Office Action dated Dec. 27, 2013 for U.S. Appl. No. 13/545,944.
- Non-Final Office Action dated Dec. 23, 2014 for U.S. Appl. No. 13/545,944.
- Final Office Action dated Jun. 8, 2015 for U.S. Appl. No. 13/657,725.
- Notice of Allowance dated Jun. 29, 2015 for U.S. Appl. No. 13/663,447.
- Final Office Action dated Jan. 12, 2015 for U.S. Appl. No. 12/725,450.
- Non-Final Office Action dated Jun. 9, 2014 for U.S. Appl. No. 12/725,450.
- Notice of Allowance dated Nov. 28, 2014 for U.S. Appl. No. 13/111,837.
- Notice of Allowance dated Jul. 8, 2015 for U.S. Appl. No. 14/099,834.
- Foreign Office Action dated Feb. 14, 2013 for Australian Appln. No. 2010307029.
- Foreign Office Action dated Mar. 14, 2014 for Australian Appln. No. 2010307029.
- Foreign Office Action dated Apr. 17, 2015 for Canadian Appln. No. 2,777,228.
- Foreign Office Action dated May 6, 2014 for Canadian Patent Appln. No. 2777228.
- Foreign Office Action dated Jun. 17, 2014 for European Appln. No. 10823909.6.
- Foreign Office Action dated Nov. 27, 2014 for Indonesian Appln. No. W00201201713.
- Foreign Office Action dated Jul. 21, 2014 for Israeli Application No. 219083.
- Foreign Office Action dated Apr. 8, 2014 for Japanese Patent Appln. No. 2012-533385.
- Foreign Office Action dated Dec. 16, 2014 for Japanese Patent Appln. No. 2012-533385.
- Foreign Office Action dated Feb. 26, 2014 for Korean Application No. 10-2012-701259.
- Foreign Office Action dated Nov. 20, 2014 for Korean Application No. 10-2012-701259.
- Non-Final Office Action dated Aug. 1, 2014 for U.S. Appl. No. 12/902,133.
- Notice of Allowance dated Jan. 20, 2015 for U.S. Appl. No. 12/902,133.
- Final Office Action dated Jan. 13, 2015 for U.S. Appl. No. 12/966,943.

(56)

References Cited

OTHER PUBLICATIONS

- Final Office Action dated Aug. 18, 2015 for U.S. Appl. No. 12/966,943.
- Non-Final Office Action dated Sep. 11, 2014 for U.S. Appl. No. 12/966,943.
- Final Office Action dated Jan. 15, 2016 for U.S. Appl. No. 13/960,743.
- Non-Final Office Action dated Apr. 20, 2015 for U.S. Appl. No. 13/960,743.
- Final Office Action dated Feb. 11, 2016 for U.S. Appl. No. 13/966,212.
- Non-Final Office Action dated Jul. 20, 2015 for U.S. Appl. No. 13/966,212.
- Final Office Action dated Jan. 15, 2015 for U.S. Appl. No. 12/966,954.
- Non-Final Office Action dated Jun. 26, 2014 for U.S. Appl. No. 12/966,954.
- Advisory Action dated Apr. 21, 2014 for U.S. Appl. No. 13/246,775.
- Final Office Action dated Jan. 13, 2014 for U.S. Appl. No. 13/246,775.
- Non-Final Office Action dated Sep. 17, 2014 for U.S. Appl. No. 13/246,775.
- Final Office Action dated May 22, 2015 for U.S. Appl. No. 13/487,118.
- Non-Final Office Action dated Oct. 8, 2014 for U.S. Appl. No. 13/487,118.
- Advisory Action dated Jan. 22, 2015 for U.S. Appl. No. 13/487,121.
- Final Office Action dated Jan. 14, 2015 for U.S. Appl. No. 13/487,121.
- Final Office Action dated Aug. 14, 2015 for U.S. Appl. No. 13/487,121.
- Non-Final Office Action dated Sep. 11, 2014 for U.S. Appl. No. 13/487,121.
- Final Office Action dated Feb. 24, 2015 for U.S. Appl. No. 13/487,135.
- Non-Final Office Action dated Sep. 12, 2014 for U.S. Appl. No. 13/487,135.
- Non-Final Office Action dated Jun. 19, 2015 for U.S. Appl. No. 13/896,252.
- Final Office Action dated Jun. 5, 2015 for U.S. Appl. No. 14/207,511.
- Non-Final Office Action dated Oct. 3, 2014 for U.S. Appl. No. 14/207,511.
- Final Office Action dated Jun. 5, 2015 for U.S. Appl. No. 14/207,516.
- Non-Final Office Action dated Oct. 3, 2014 for U.S. Appl. No. 14/207,516.
- Non-Final Office Action dated Apr. 24, 2015 for U.S. Appl. No. 14/207,526.
- Notice of Allowance dated Aug. 19, 2014 for U.S. Appl. No. 13/048,837.
- Notice of Allowance dated Nov. 7, 2014 for U.S. Appl. No. 13/048,837.
- Notice of Allowance dated Jul. 20, 2015 for U.S. Appl. No. 13/896,247.
- Notice of Allowance dated Nov. 26, 2014 for U.S. Appl. No. 13/048,844.
- Non-Final Office Action dated Sep. 29, 2015 for U.S. Appl. No. 14/562,477.
- Non-Final Office Action dated Nov. 24, 2014 for U.S. Appl. No. 13/091,116.
- Non-Final Office Action dated Nov. 6, 2014.
- Notice of Allowance dated Jun. 5, 2015 for U.S. Appl. No. 13/091,116.
- Non-Final Office Action dated Mar. 12, 2015 for U.S. Appl. No. 13/228,366.
- Non-Final Office Action dated Jan. 28, 2015 for U.S. Appl. No. 13/246,763.
- Notice of Allowance dated Mar. 6, 2014 for U.S. Appl. No. 13/523,835.
- Notice of Allowance dated Oct. 27, 2014 for U.S. Appl. No. 13/523,835.
- Notice of Allowance dated Nov. 7, 2014 for U.S. Appl. No. 13/523,835.
- Non-Final Office Action dated Apr. 28, 2015 for U.S. Appl. No. 14/207,642.
- Foreign Office Action for CN Patent Application No. 201110378545.2 dated Jan. 13, 2014.
- Examination Report dated Jun. 16, 2014 for European Application No. 11758075.3.
- European Examination Report dated Jun. 18, 2014 for EP Appln. No. 10810835.8.
- Final Office Action dated Jan. 26, 2015 for U.S. Appl. No. 12/902,135.
- Non-Final Office Action dated Apr. 1, 2014 for U.S. Appl. No. 12/902,135.
- Non-Final Office Action dated Apr. 22, 2015 for U.S. Appl. No. 13/717,401.
- Non-Final Office Action dated Jun. 5, 2015 for U.S. Appl. No. 13/751,133.
- Notice of Allowance dated Jan. 5, 2016 for U.S. Appl. No. 13/751,133.
- Final Office Action dated Jan. 4, 2016 for U.S. Appl. No. 14/015,331.
- Non-Final Office Action dated Mar. 23, 2015 for U.S. Appl. No. 14/015,331.
- International Search Report and Written Opinion for PCT/US14/22141 dated Jul. 9, 2014.
- Ebbini et al. A spherical-section ultrasound phased array applicator for deep localized hyperthermia. 1991 IEEE Trans. Biom. Eng. 38:634-643.
- Eckberg Physiological basis for human autonomic rhythms. 2000 Ann.Med. 32:341-349.
- Fowlkes, J. Brian, and Christy K. Holland. "Mechanical bioeffects from diagnostic ultrasound: AIUM consensus statements. American Institute of Ultrasound in Medicine." Journal of ultrasound in medicine: official journal of the American Institute of Ultrasound in Medicine 19.2 (2000): 69-72.
- Henry Gray, "The Skull" 1918.
- Janssen, B. J., and J. F. Smits. "Renal nerves in hypertension." Mineral and electrolyte metabolism 15.1-2 (1988): 74-82.
- Karmakar. Thoracic paravertebral block. 2001 Anesth. 95:771-780.
- Kirk Shung, K., et al. "Ultrasonic characterization of blood during coagulation." Journal of clinical ultrasound 12.3 (1984): 147-153.
- Kostreva et al. Reflex effects of hepatic baroreceptors on renal and cardiac sympathetic nerve activity. 1980 Am. J. Physiol. 238:R390-R394.
- Liedtke et al. Total systemic autoregulation in the dog and its inhibition by baroreceptor reflexes. 1973 Cir. Res. 32:673-677.
- Liu et al. a fast and conformal heating scheme for producing large thermal lesions using a 20 ultrasound phased array. 2007 Int. J. Hyperthermia 23:69-82.
- Lohmeier et al. Prolonged activation of the baroreflex abolishes obesity-induced hypertension. 2007 Hypertension 49:1307-1314.
- Lohmeier et al. Prolonged Activation of the Baroreflex Produces Sustained Hypotension. 2004 Hypertension 43:306-311.
- N. F. Sheahan et al., "Observing the brachial artery through a pressure cuff", 1993.
- Paul D. Indman, "What is Hysteroscopy" <http://www.gynalternatives.com/hsc.htm>, accessed on 2010.
- Pernot et al. 3-D Real-time motion correction in high-intensity focused ultrasound therapy. 2004 Ultrasound Med. Biol. 30:1239-1249.
- Pernot, Mathieu, et al. "Temperature estimation using ultrasonic spatial compound imaging." Ultrasonics, Ferroelectrics and Frequency Control, IEEE Transactions on 51.5 (2004): 606-615.
- Rabkin et al. "Biology and Physical Mechanisms of HIFU-Induced Hyperecho in Ultrasound Images" 2006 Ultrasound in Med. & Bioi. 32:1721-1729.
- Ralls. Color doppler sonography of the hepatic artery and portal venous system. 1990 Am. J. Roentgenology 155:517-525.
- Recchia et al., "Ultrasonic tissue characterization of blood during stasis and thrombosis with a real-time linear-array backscatter imaging system", Coronary Artery Disease, 1993.
- Rose, J.L., "Ultrasonic Waves in Solid Media", 1999.

(56)

References Cited

OTHER PUBLICATIONS

Shanta. Unilateral bronchospasm after interpleural analgesia. 1992 Anesth. Analg. 74:291-293.

Sherrit, S., G. Catoiu, and B. K. Mukherjee. "The characterisation and modelling of electrostrictive ceramics for transducers." Ferroelectrics 228.1 (1999): 167-196.

Shrout, T. R., et al. "Classification of Electrostrictive Based Materials for Transducers." Proceedings of the 6th US—Japan Seminar on Dielectric and Piezoelectric Ceramics. 1993.

Simon, Claudio, Philip VanBaren, and Emad S. Ebbini. "Two-dimensional temperature estimation using diagnostic ultrasound." Ultrasonics, Ferroelectrics and Frequency Control, IEEE Transactions on 45.4 (1998): 1088-1099.

Singh et al. "Ultrasonic Hyperthermia for Cancer Treatment" 1993 Defence Science J. 43:235-241.

Vaezy et al. "Hemorrhage control using high intensity focused ultrasound" 2007 Int.J.Hyperthermia 23:203-211.

Non-Final Office Action dated Apr. 11, 2016 for U.S. Appl. No. 14/939,670.

Foreign Office Action dated Feb. 22, 2016 for Israeli Appln. No. 238653.

Search Report dated Mar. 10, 2016 for EP Appln. No. 15196135.6.

Search Report dated Mar. 29, 2016 for EP Appln. No. 13832046.0.

Foreign Office Action dated Jan. 29, 2016 for Malaysian Appln. No. PI 2012001623.

Foreign Office Action dated Mar. 1, 2016 for Japanese Appln. No. 2015-082029.

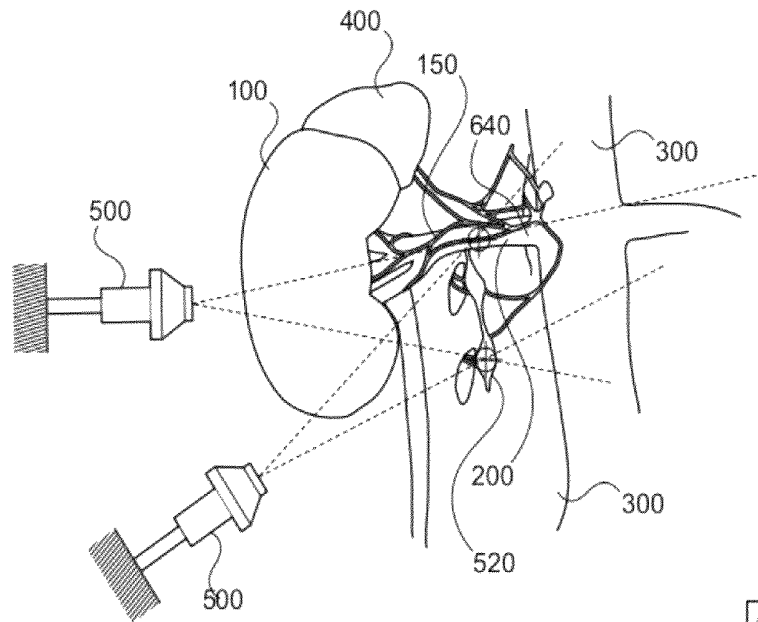

FIG. 1A

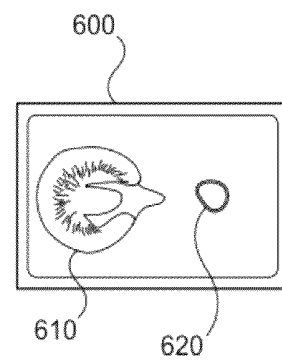

FIG. 1C

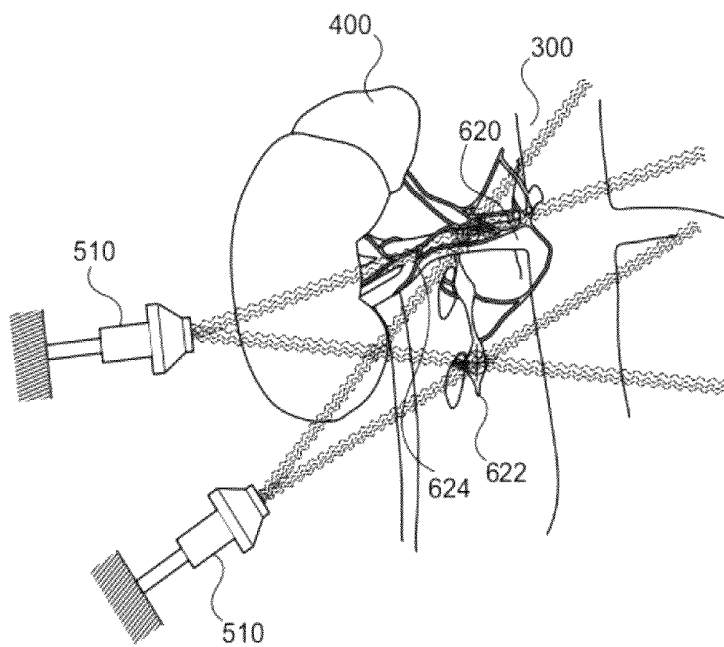

FIG. 1B

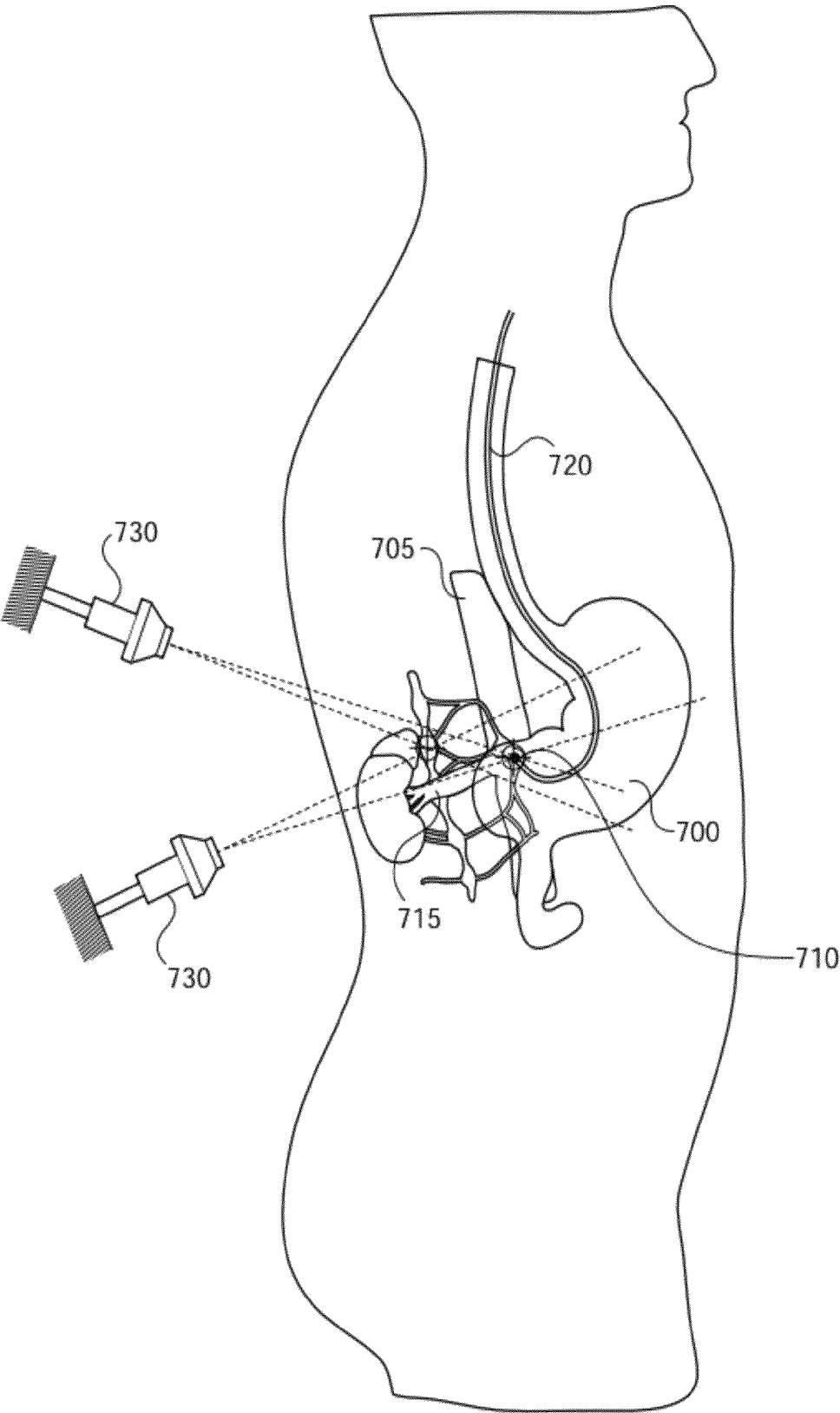

FIG. 2

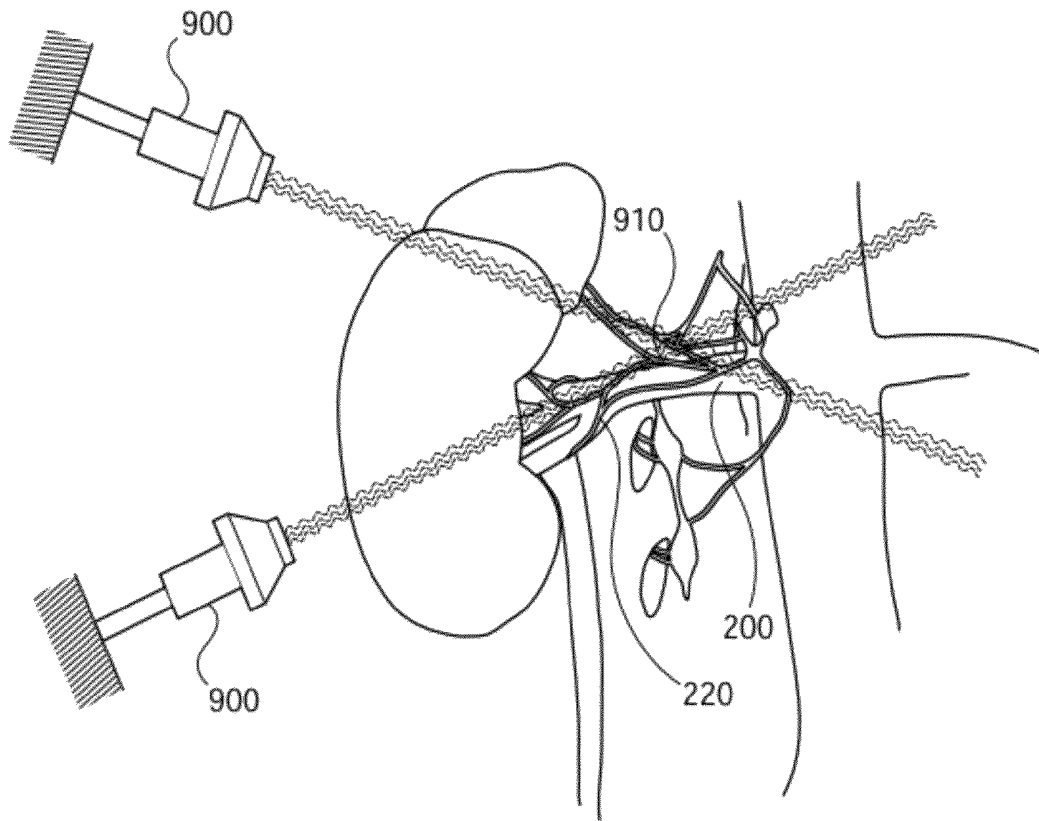

FIG. 3A

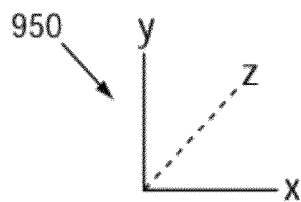

FIG. 3B

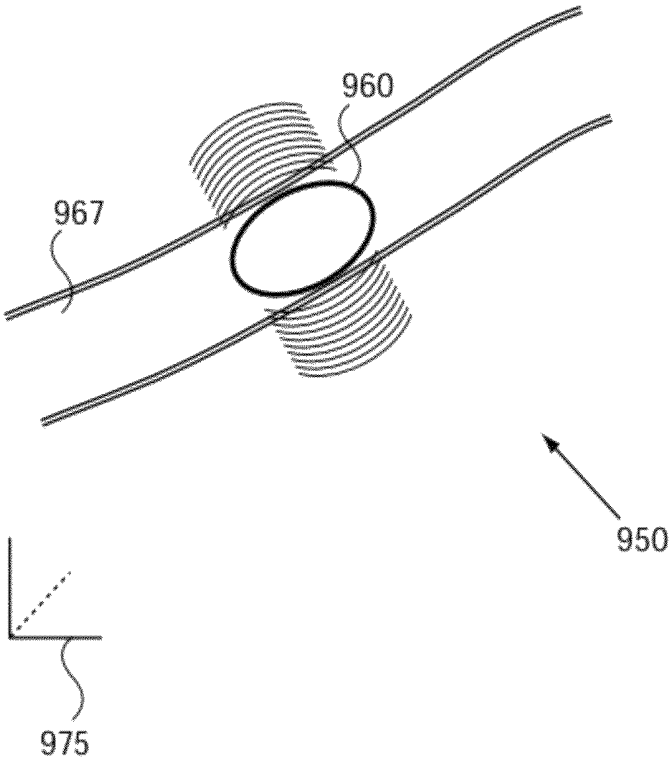

FIG. 3D

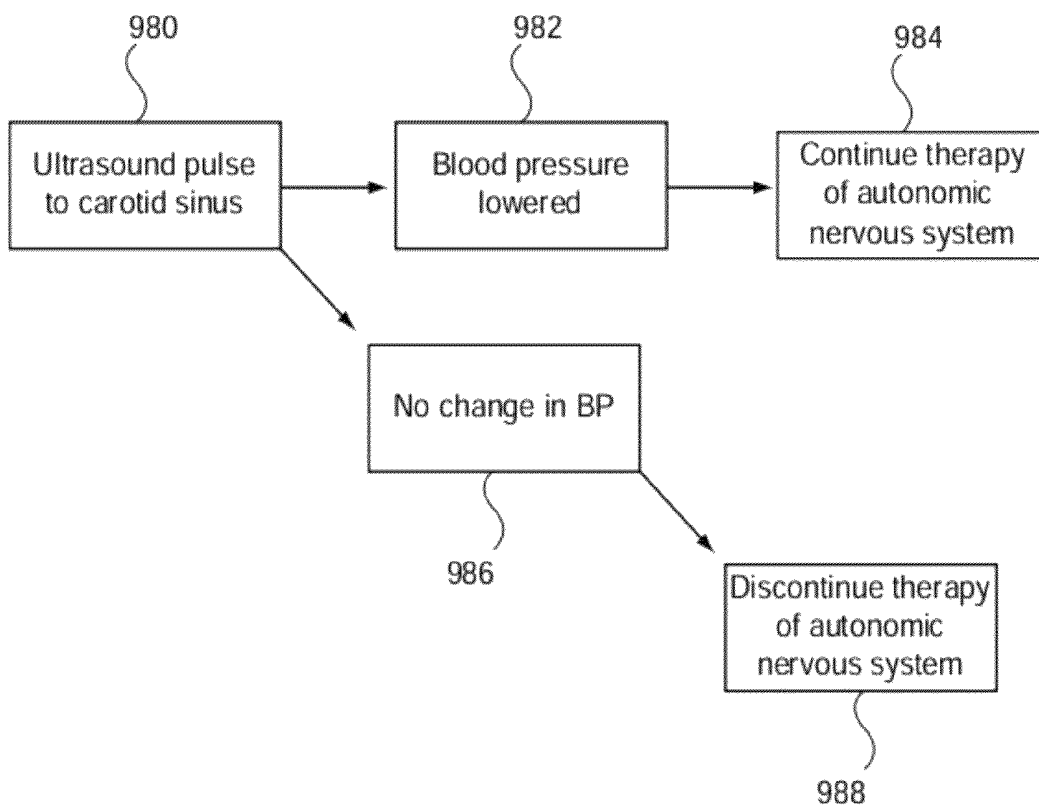

FIG. 3E

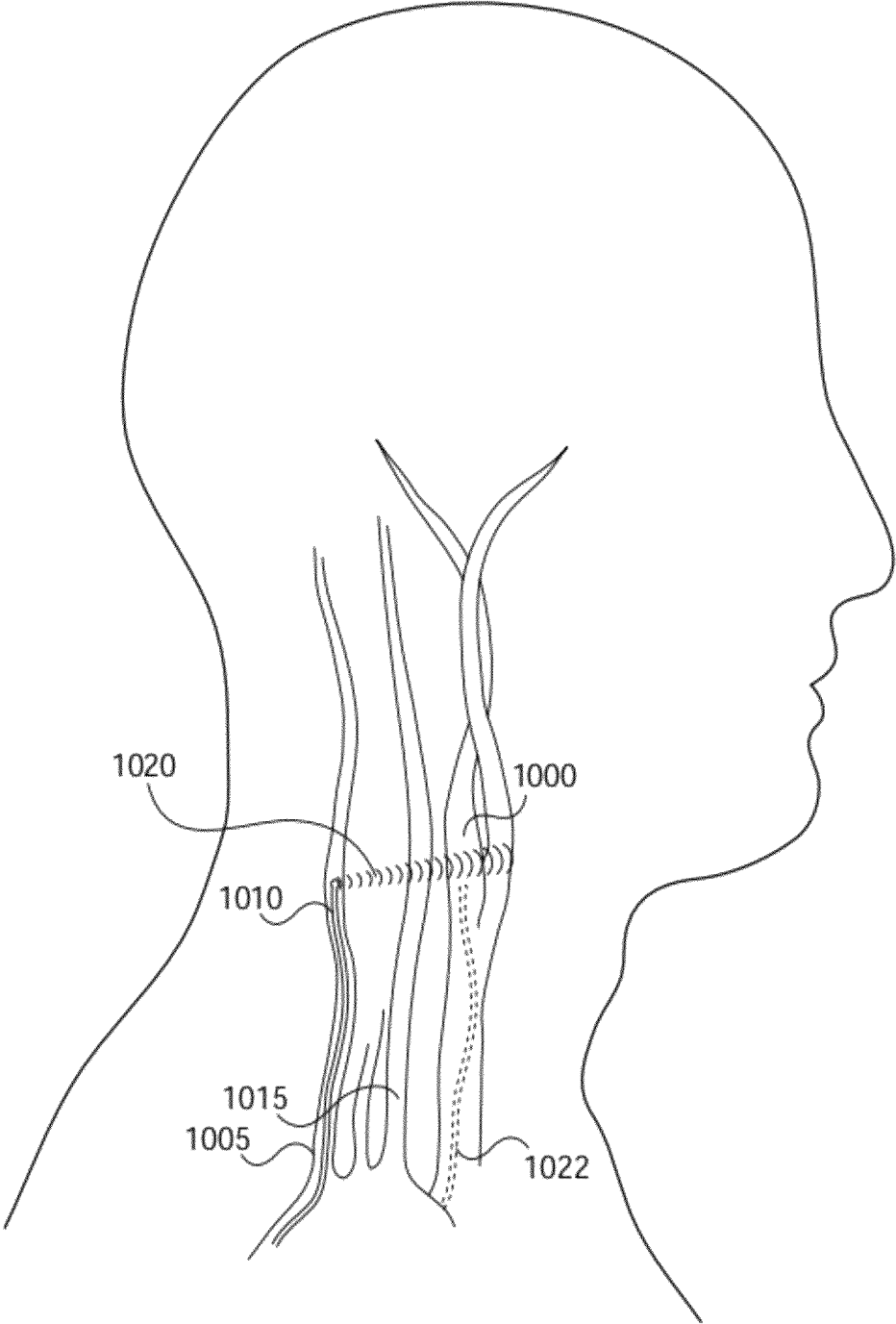

FIG. 4A

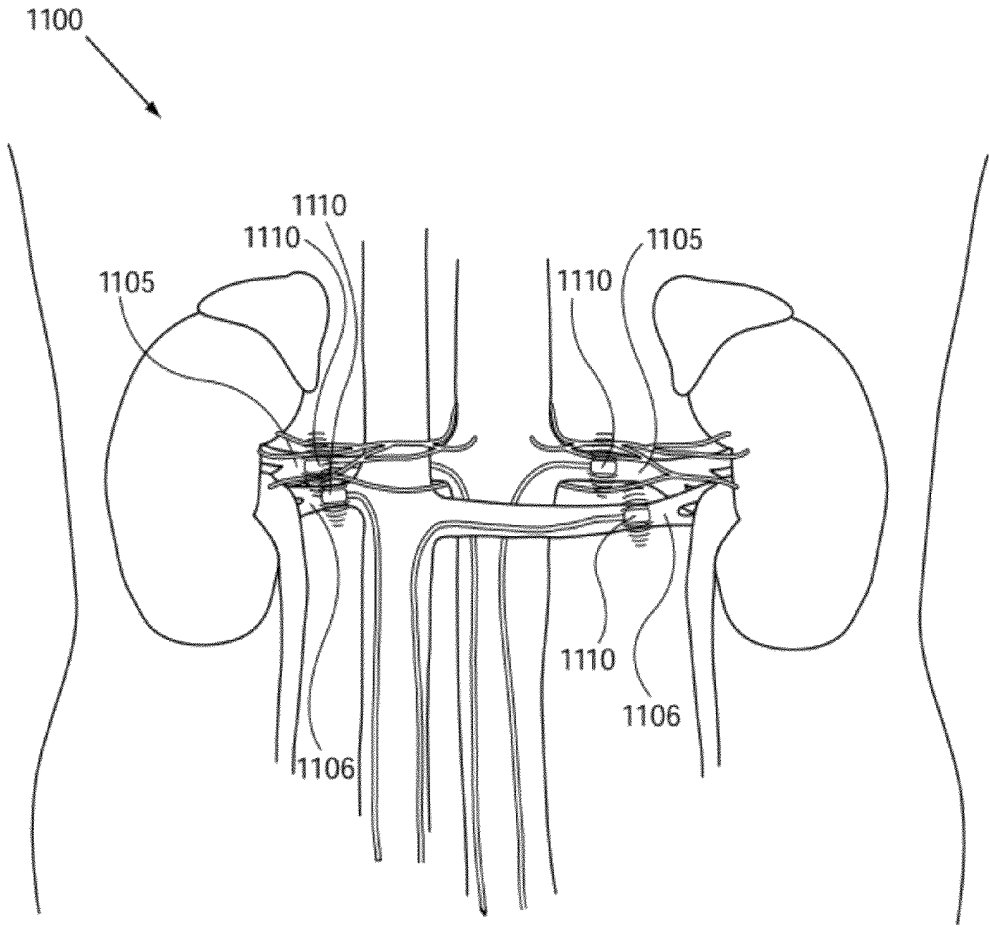

FIG. 4B

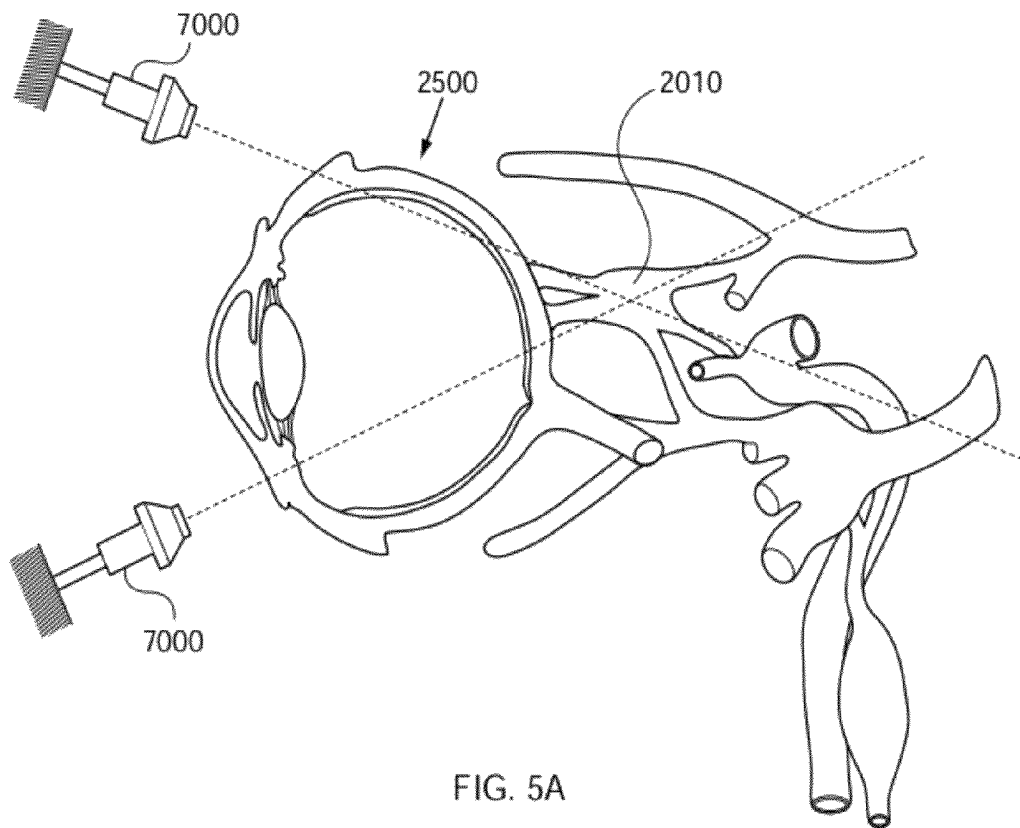

FIG. 5A

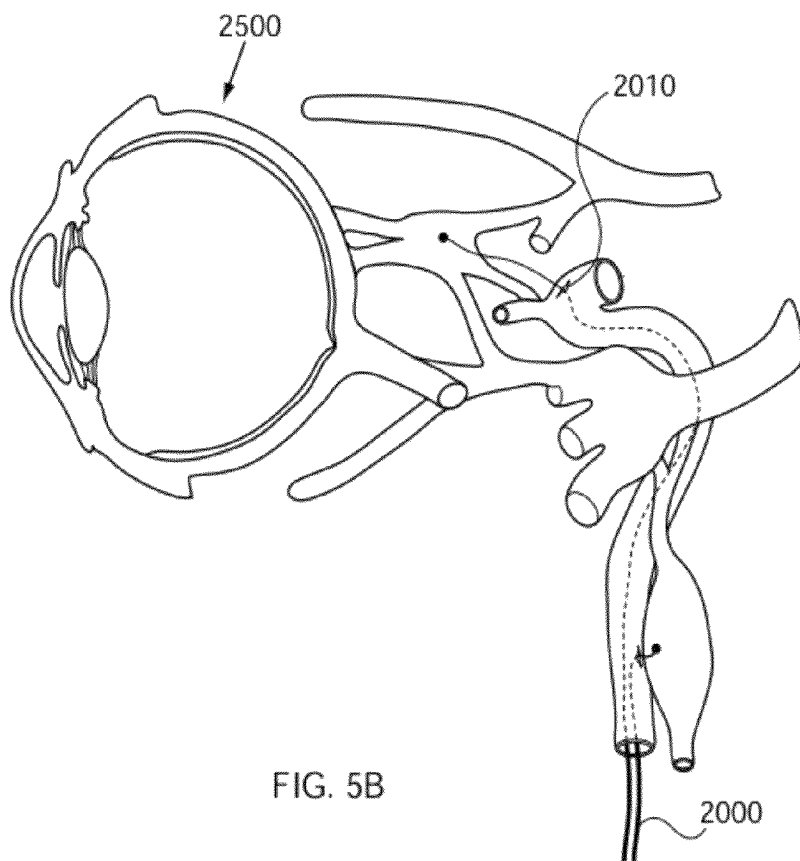

FIG. 5B

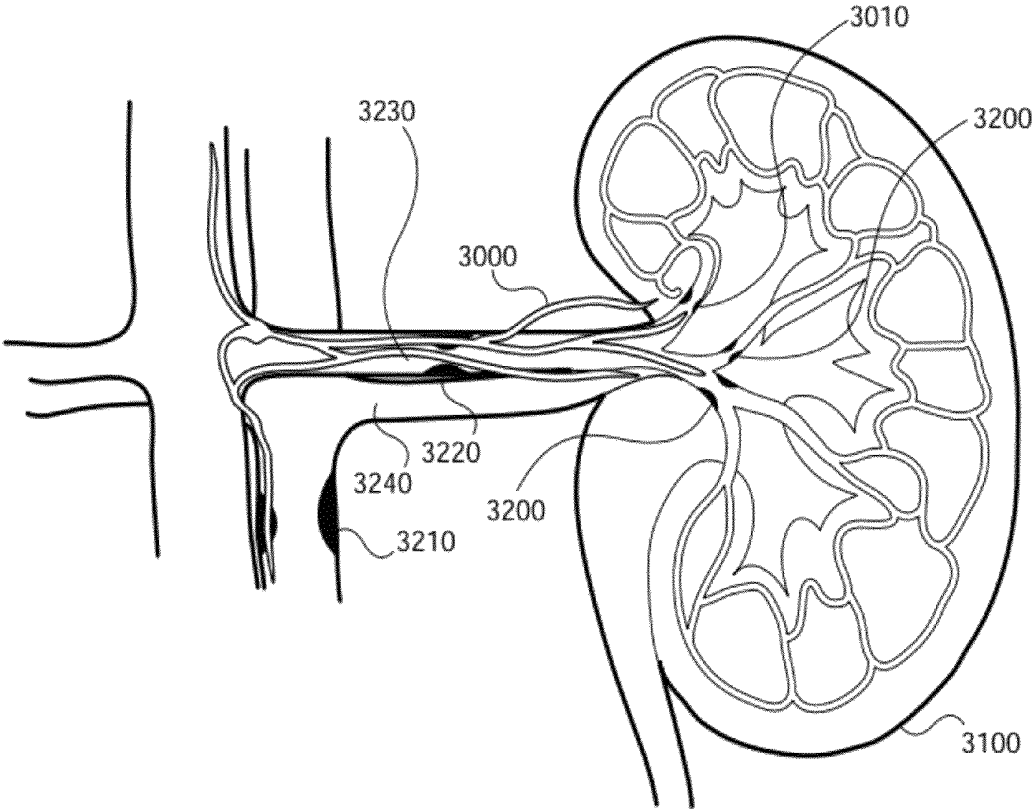

FIG. 6

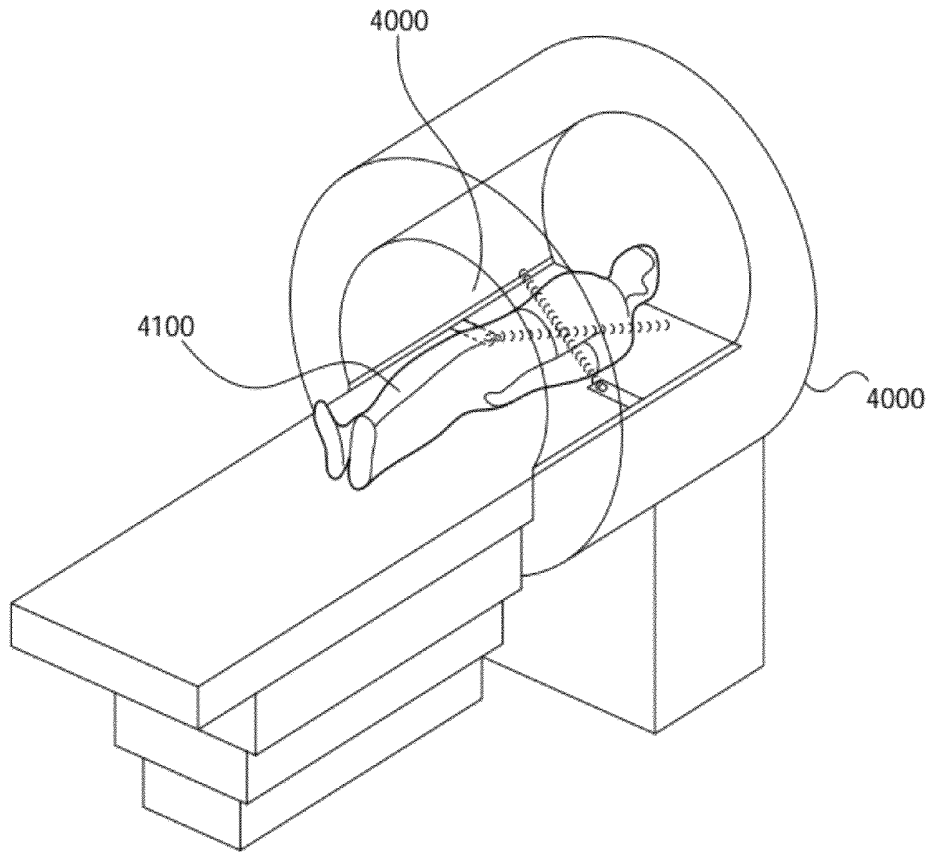

FIG. 7A

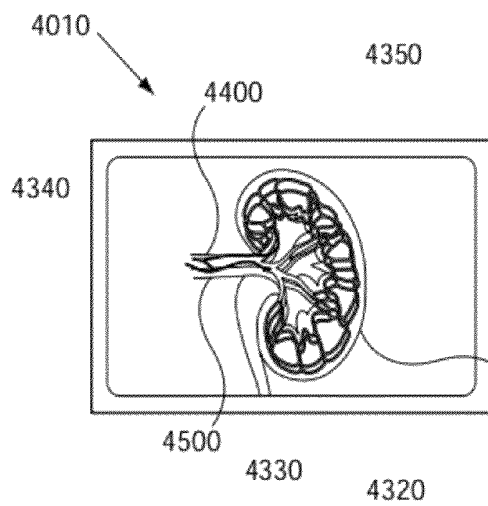

FIG. 7B

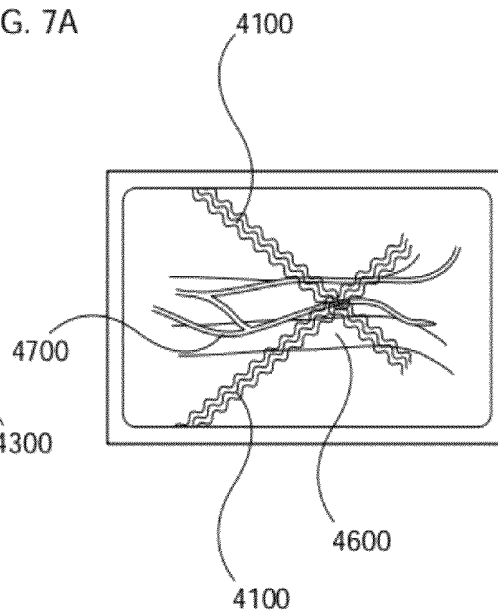

FIG. 7C

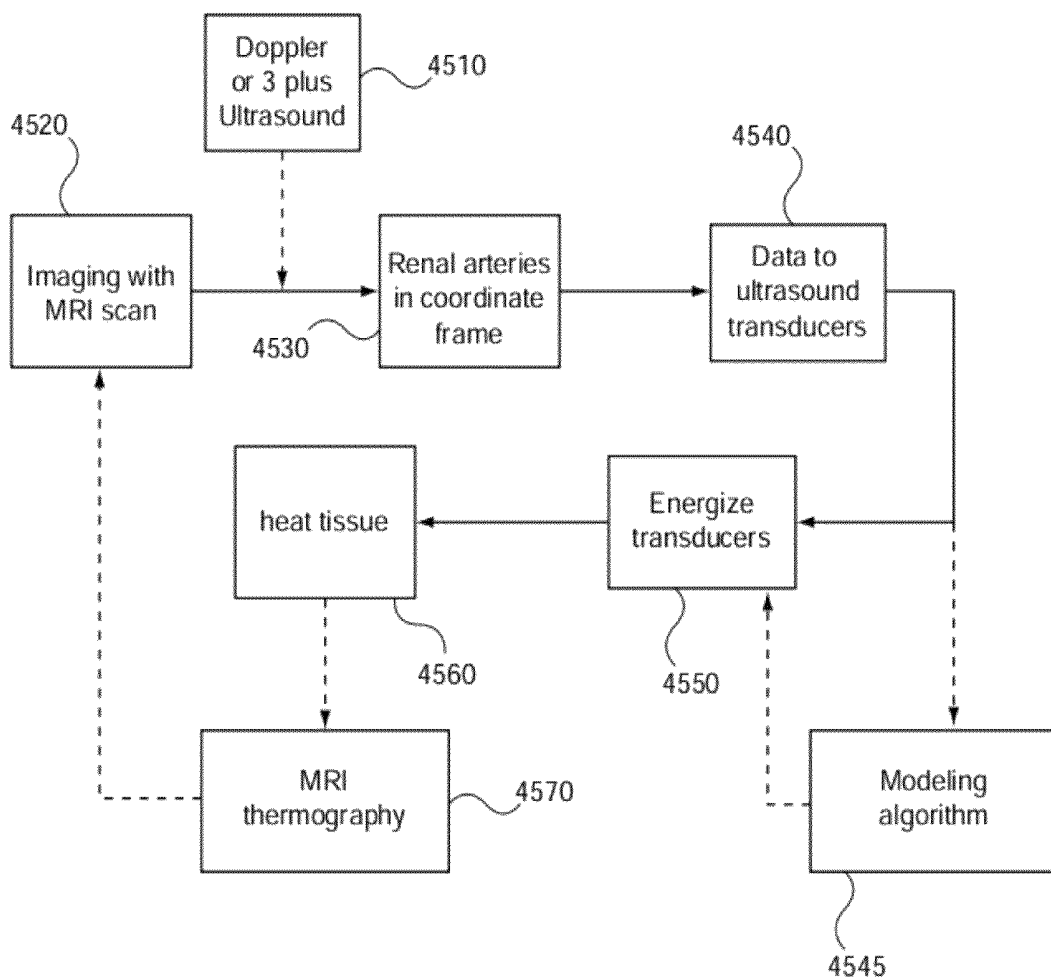

FIG. 7D

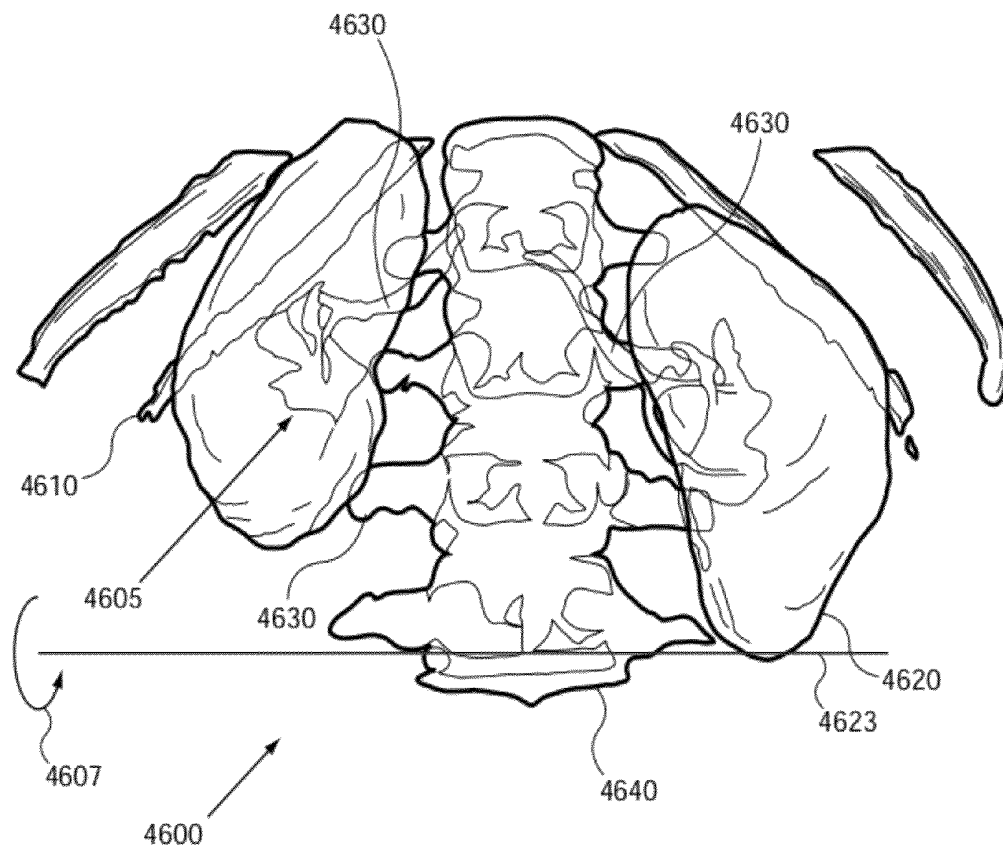

FIG. 7E

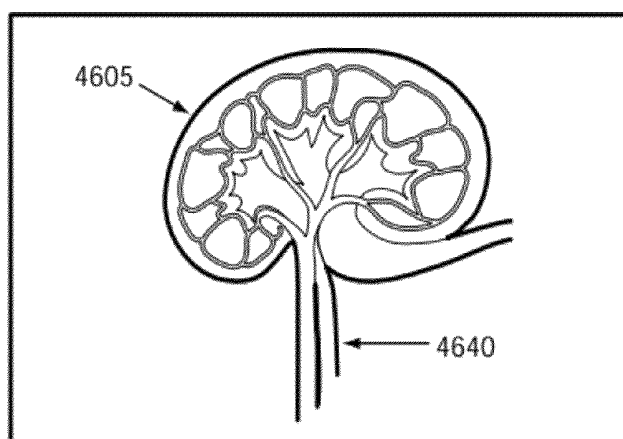

FIG. 7F

Prone Position	
STRUCTURE	DISTANCE
4770 Renal artery	6.0 - 10.0 cm
4780 Kidney hilum	4.0 cm - 8.0 cm
4790 Angle of approach	5 - 20°

4750

4740

4760

FIG. 7H

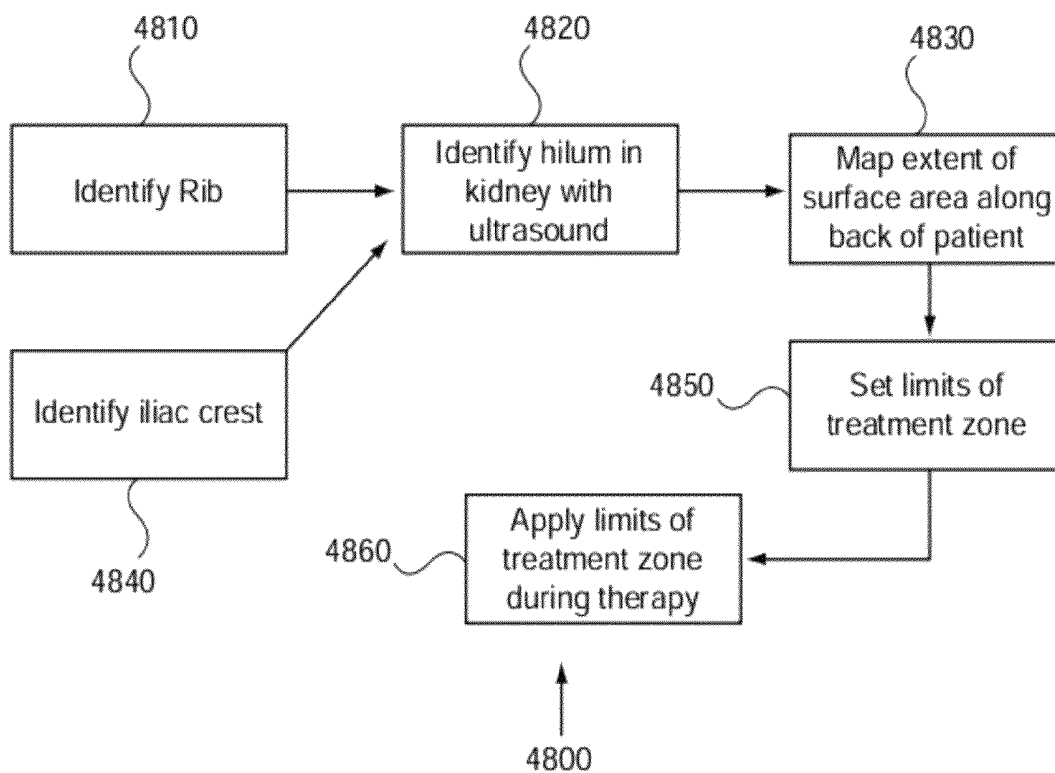
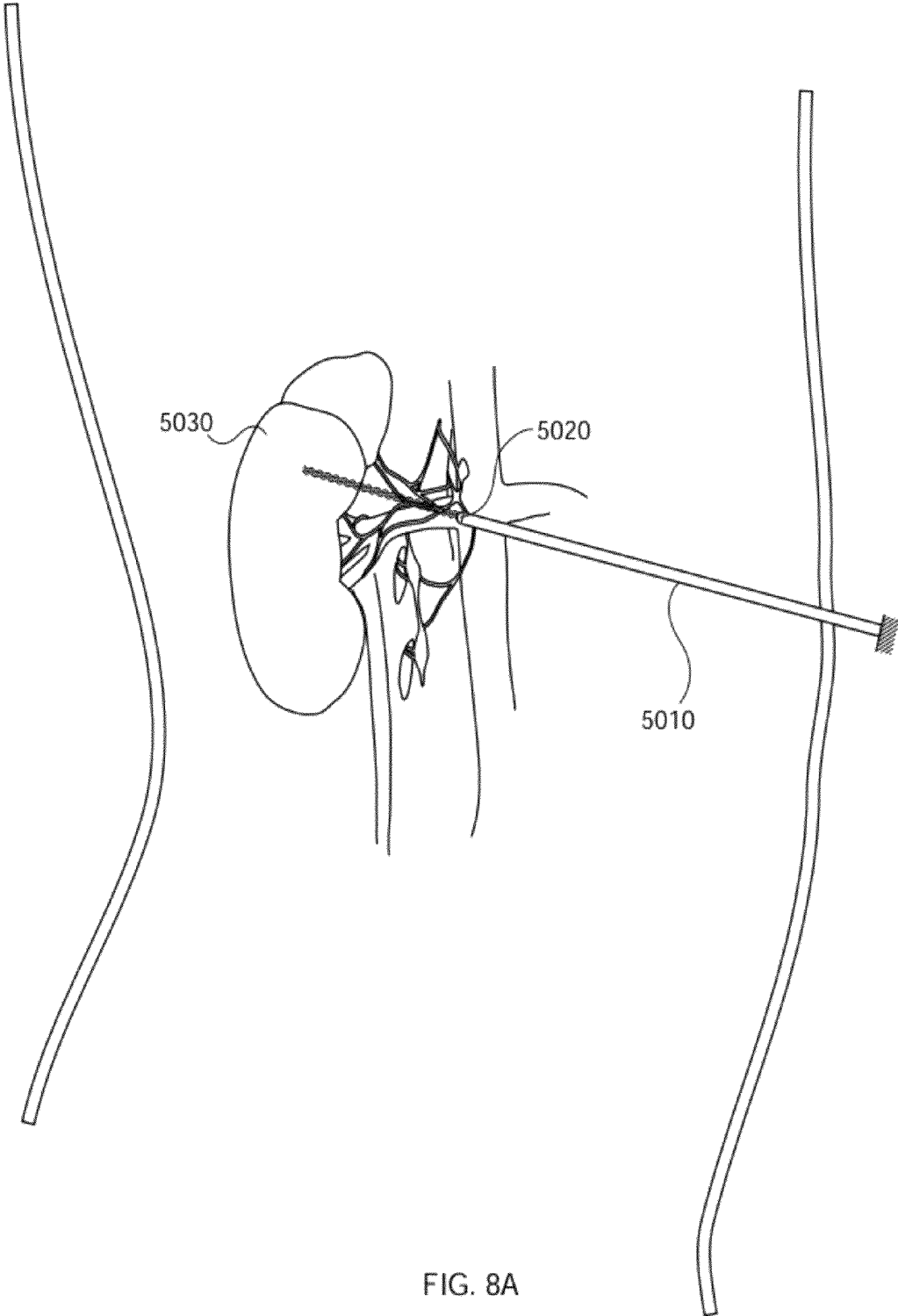

FIG. 7I



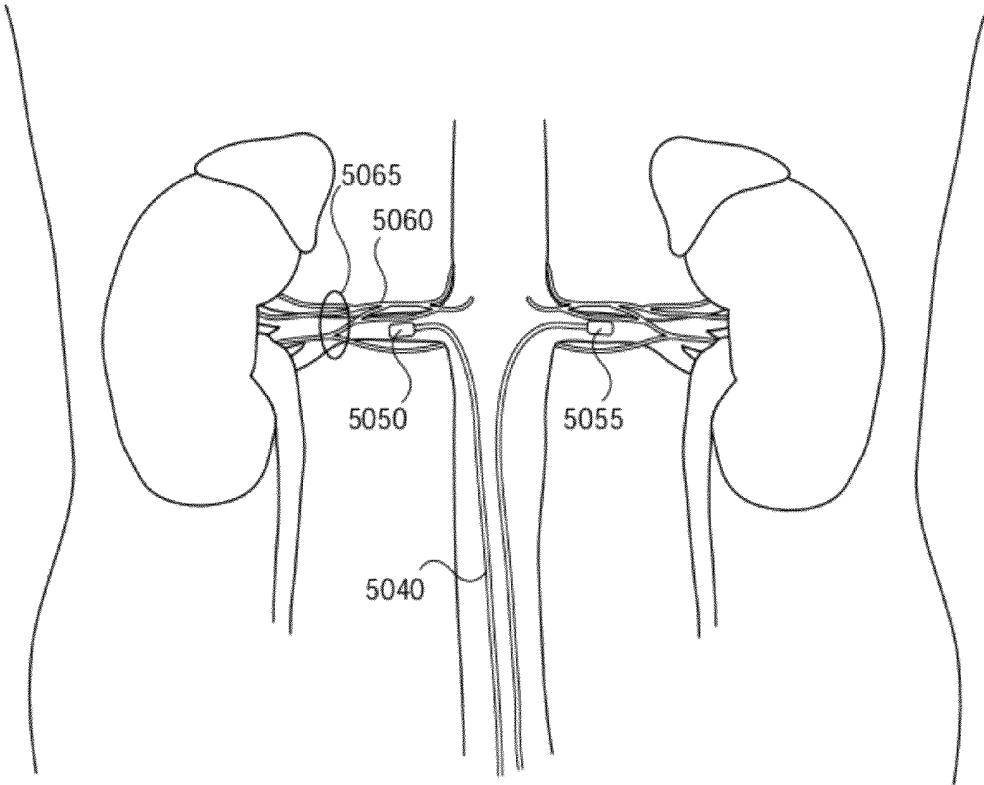

FIG. 8B

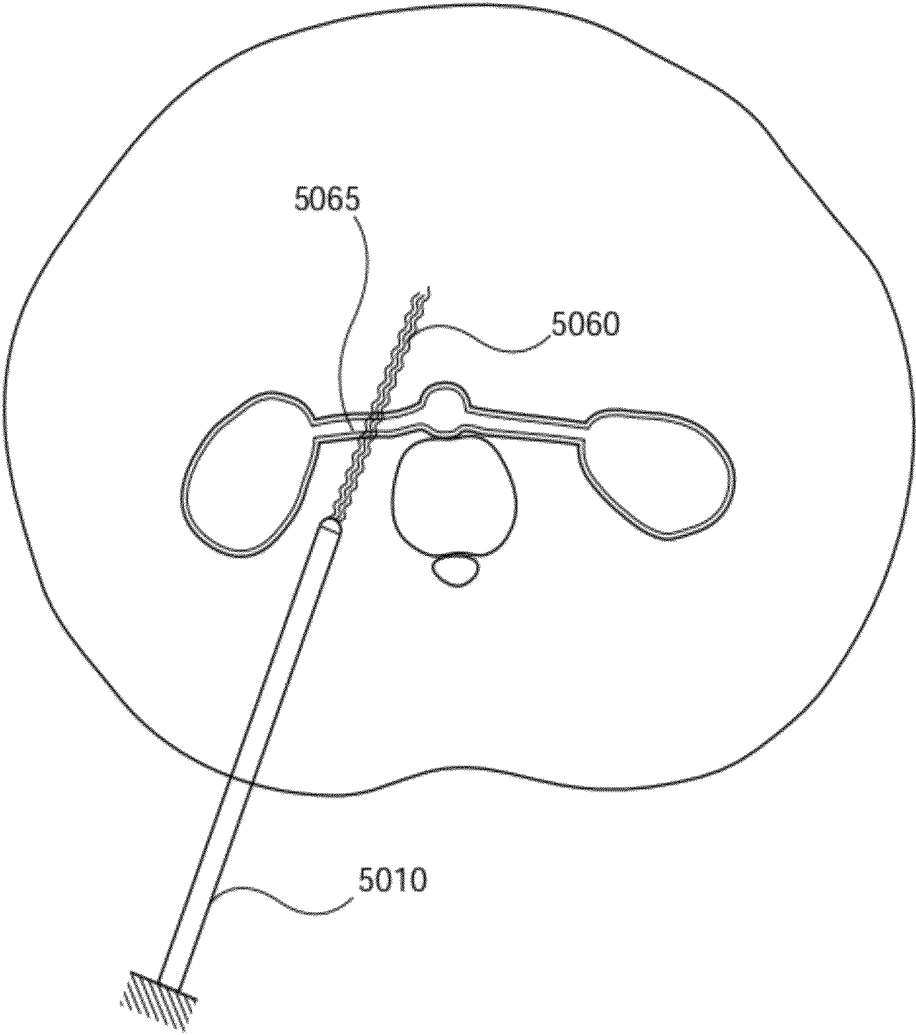

FIG. 8C

FIG. 9A

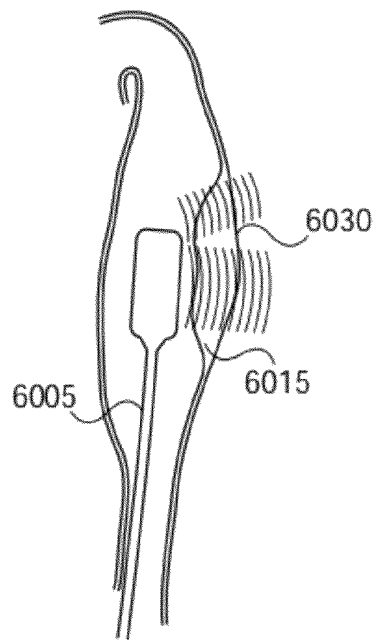

FIG. 9B

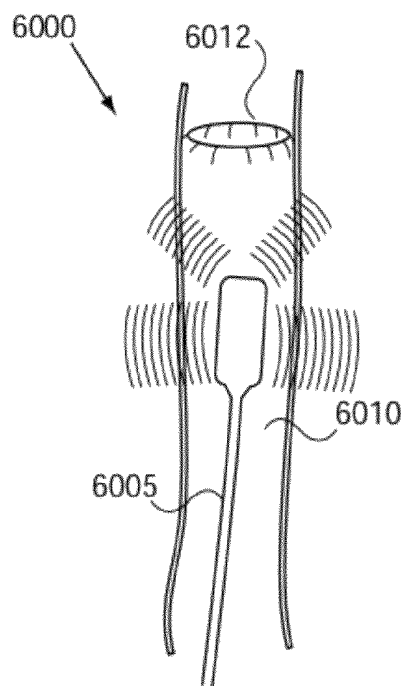
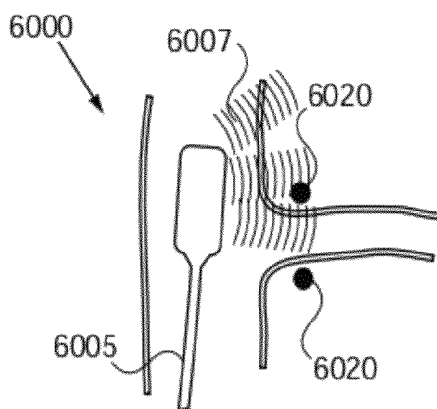

FIG. 9C



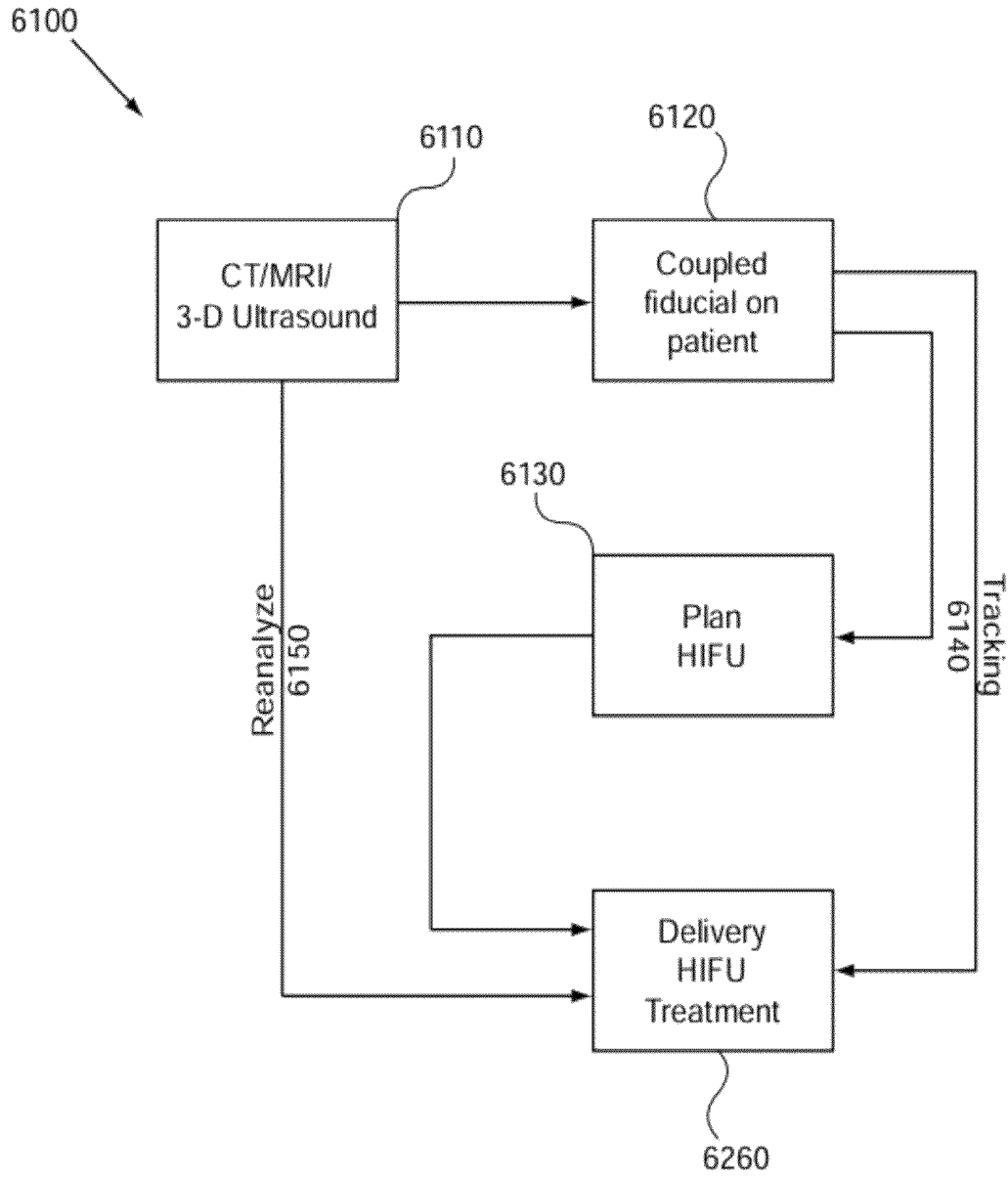

FIG. 10

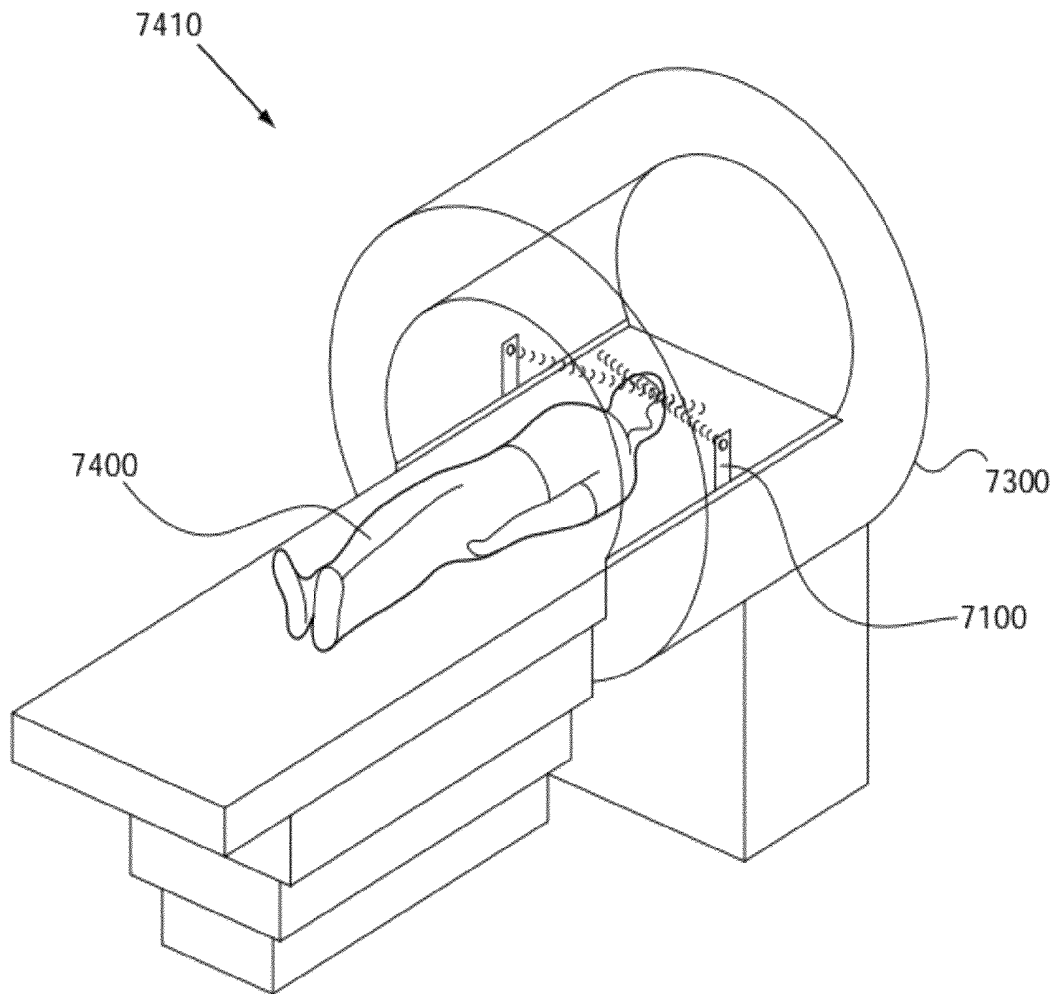

FIG. 11A

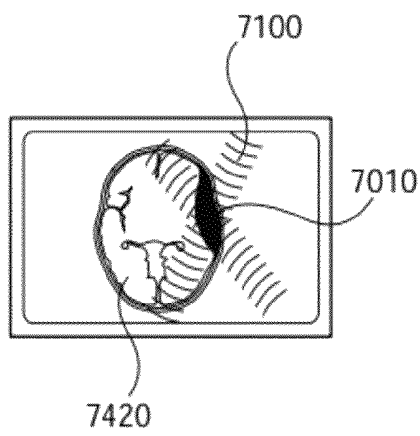

FIG. 11B

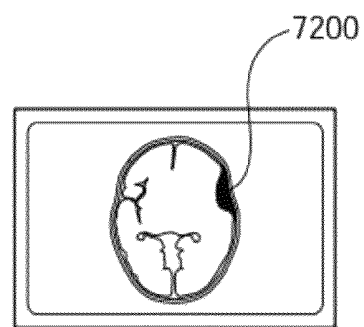

FIG. 11C

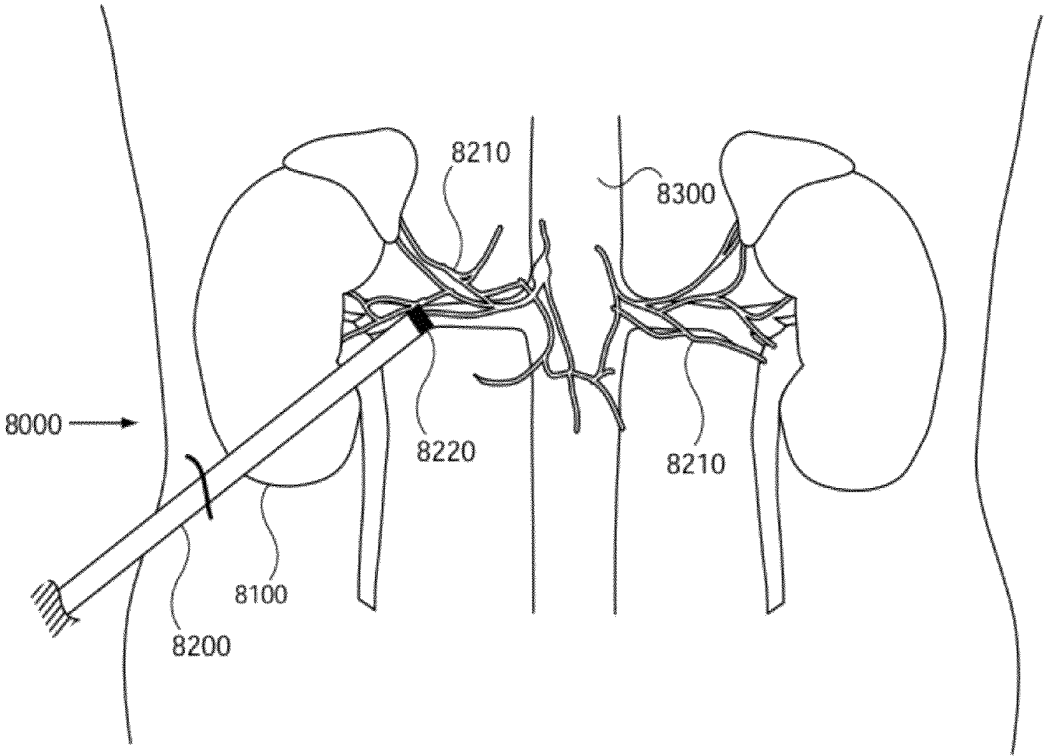

FIG. 12

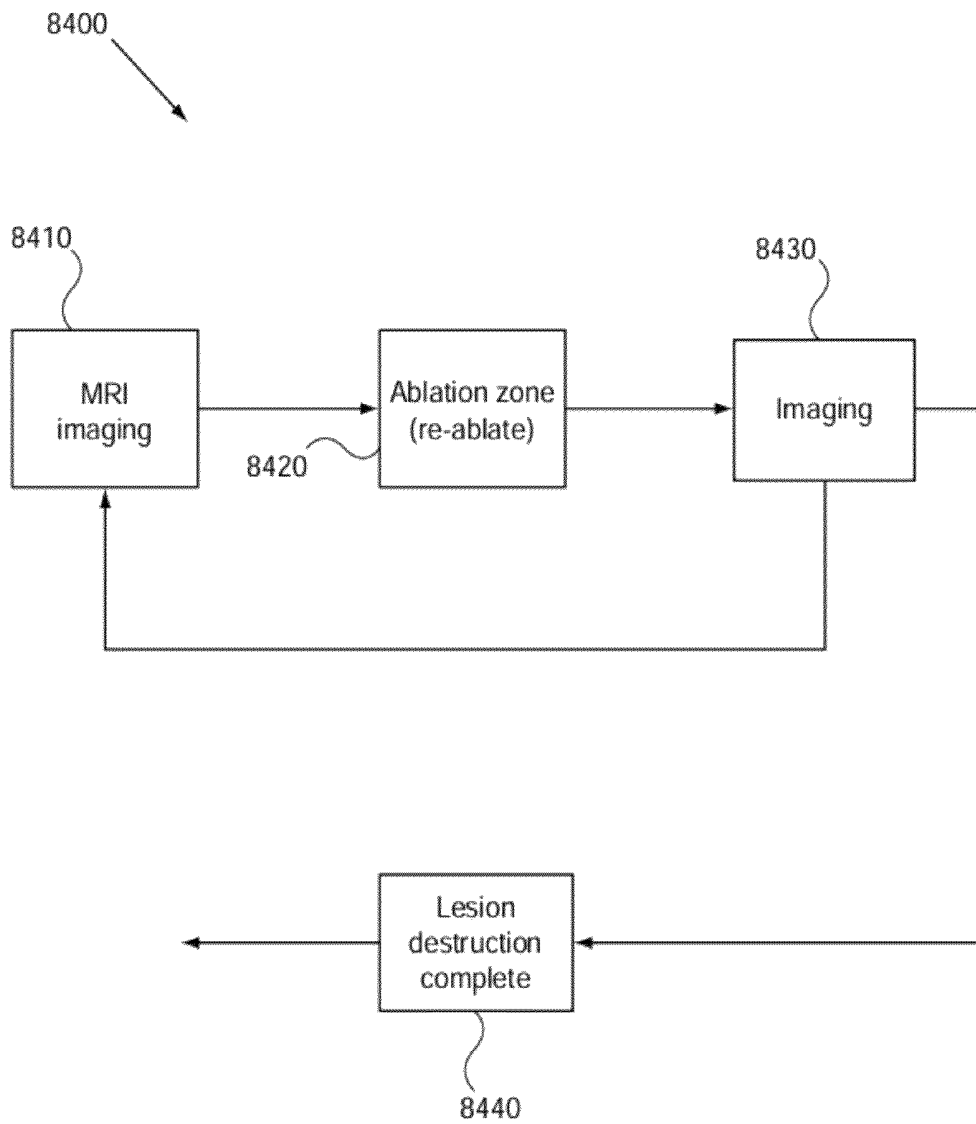

FIG. 13

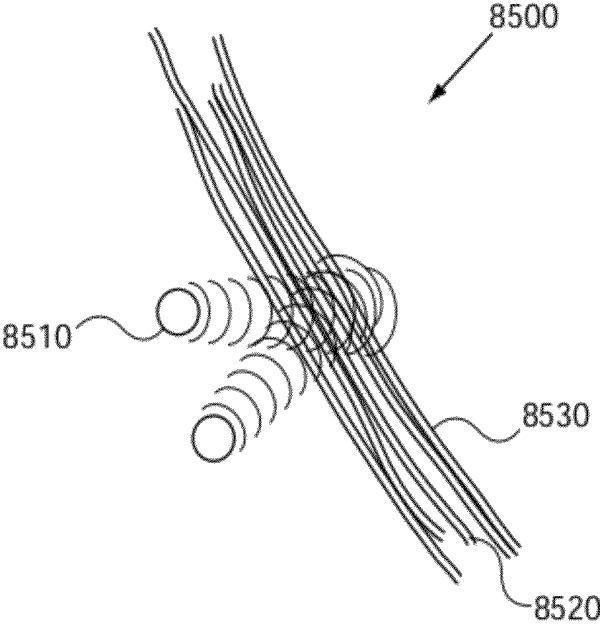

FIG. 14

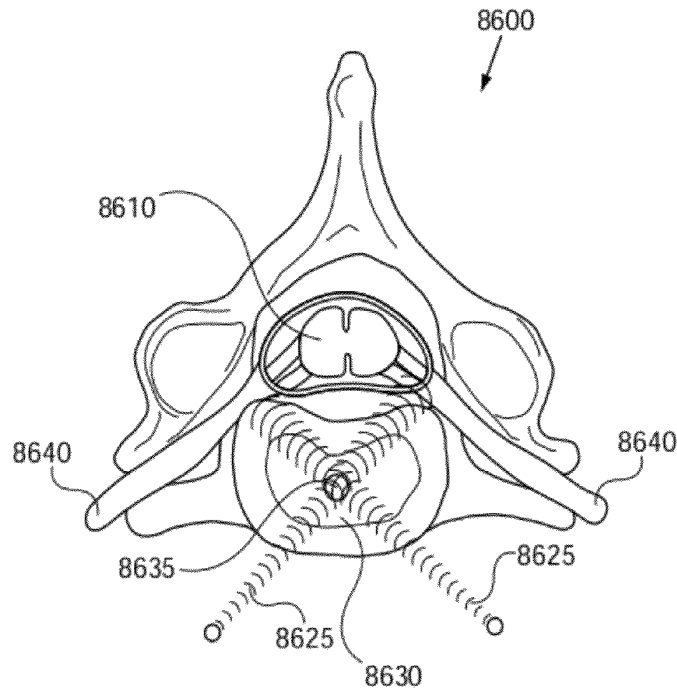

FIG. 15A

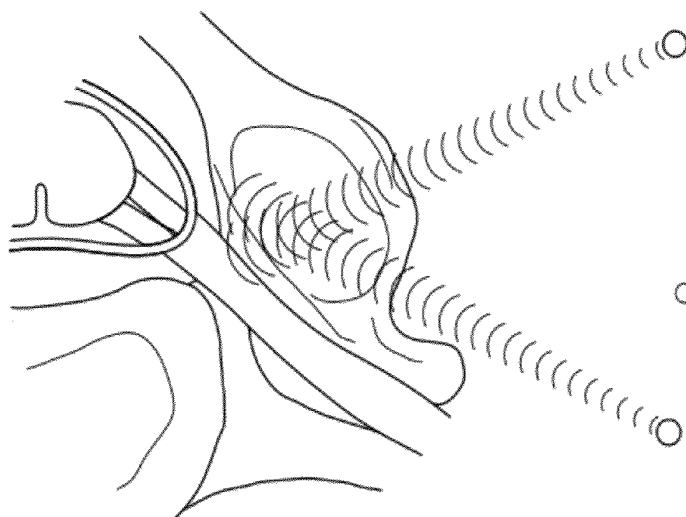

FIG. 15B

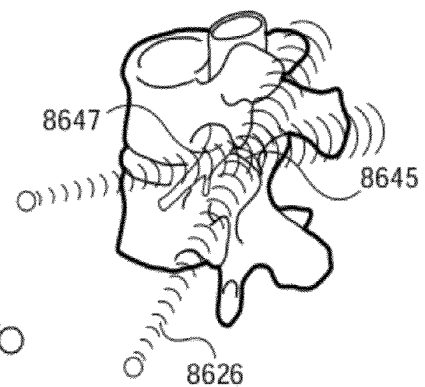

FIG. 15C

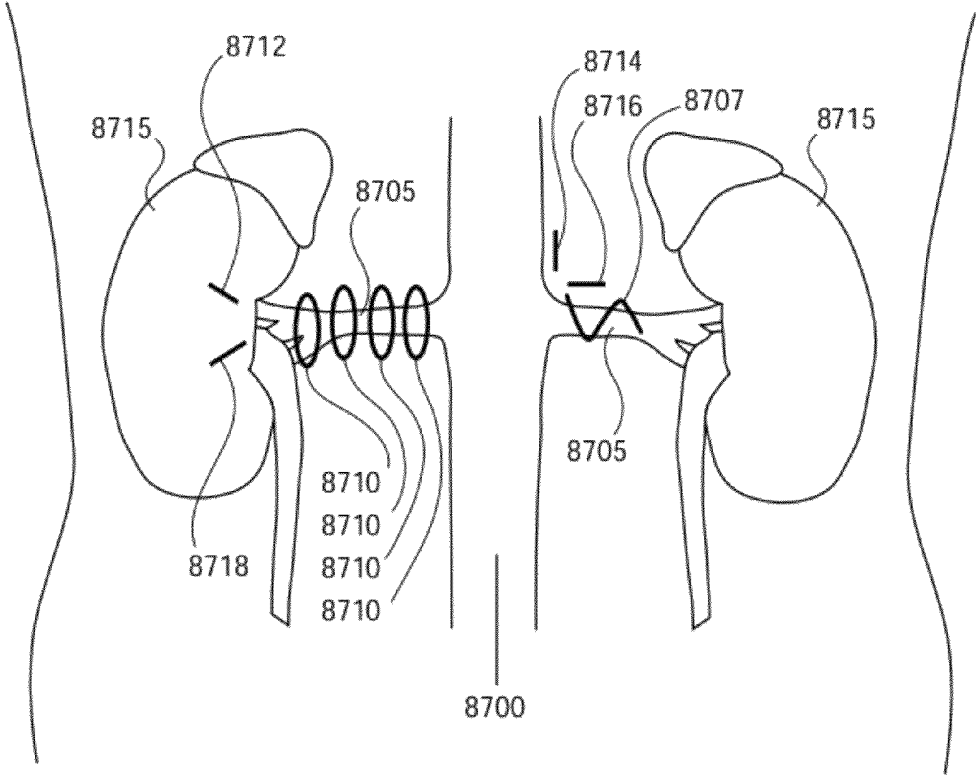

FIG. 16A

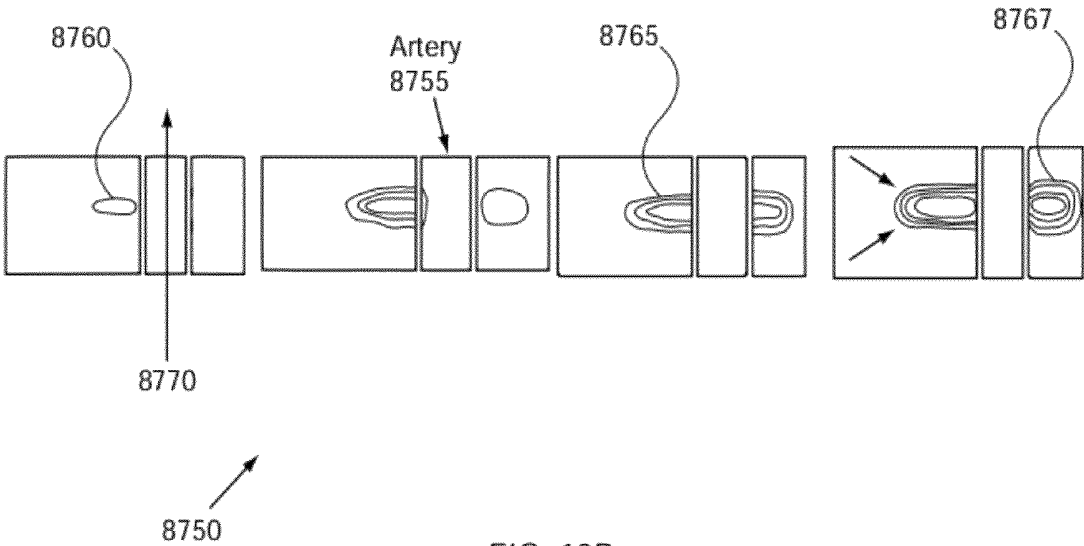

FIG. 16B

Cat Results (pg/ml)	Cortex NE Conc. (ng/g)	Avg. Cortex NE (ng/g)	Procedure
456	5	5	HIFU
543	5		HIFU
28,135	281	347	Control
41,280	413		Control
328	3	2	HIFU
96	1		HIFU
30,480	305	352	Control
39,840	398		Control

Annotations: 8780 (bracketed over Cat Results), 8780 (bracketed over Cortex NE Conc.), 8782 (bracketed over Avg. Cortex NE), 8784 (bracketed over Control rows), 8742 (bracketed over Control rows).

FIG. 16C

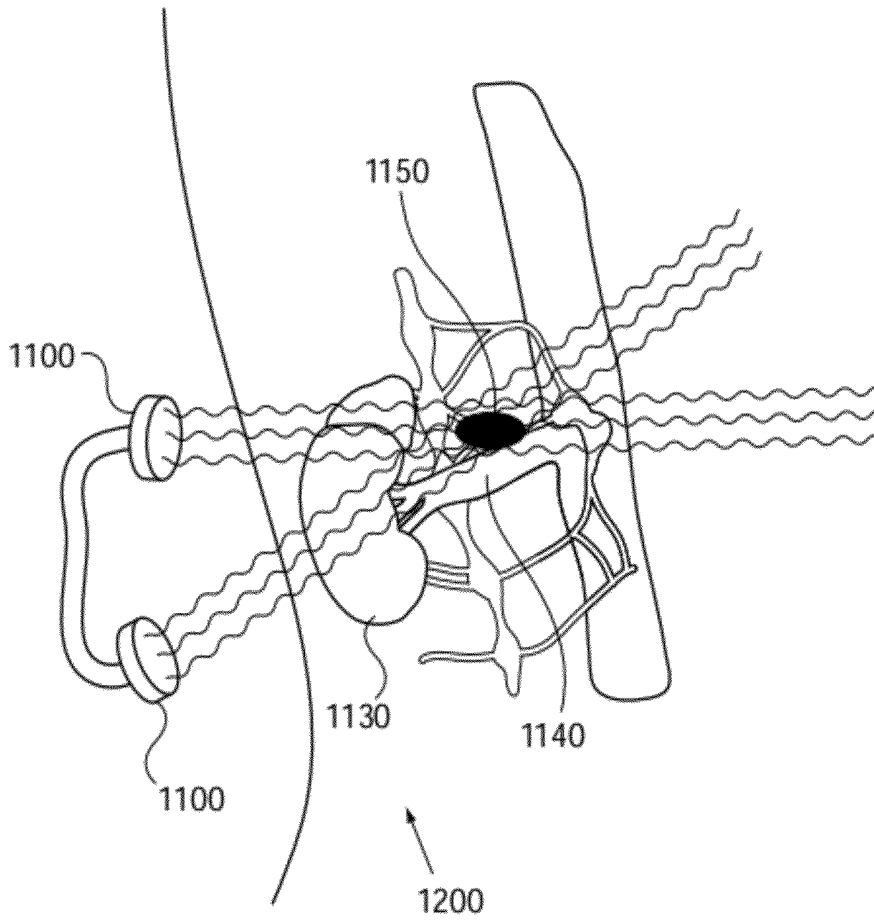

FIG. 17A

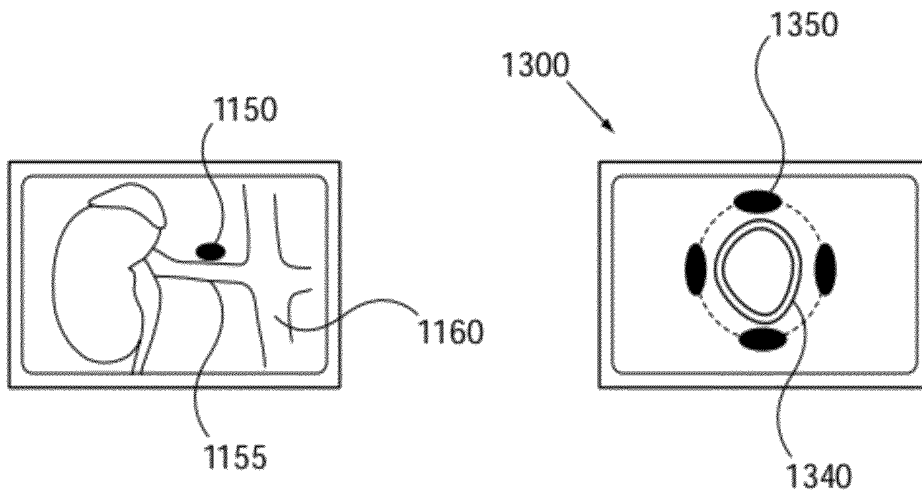

FIG. 17B

FIG. 17C

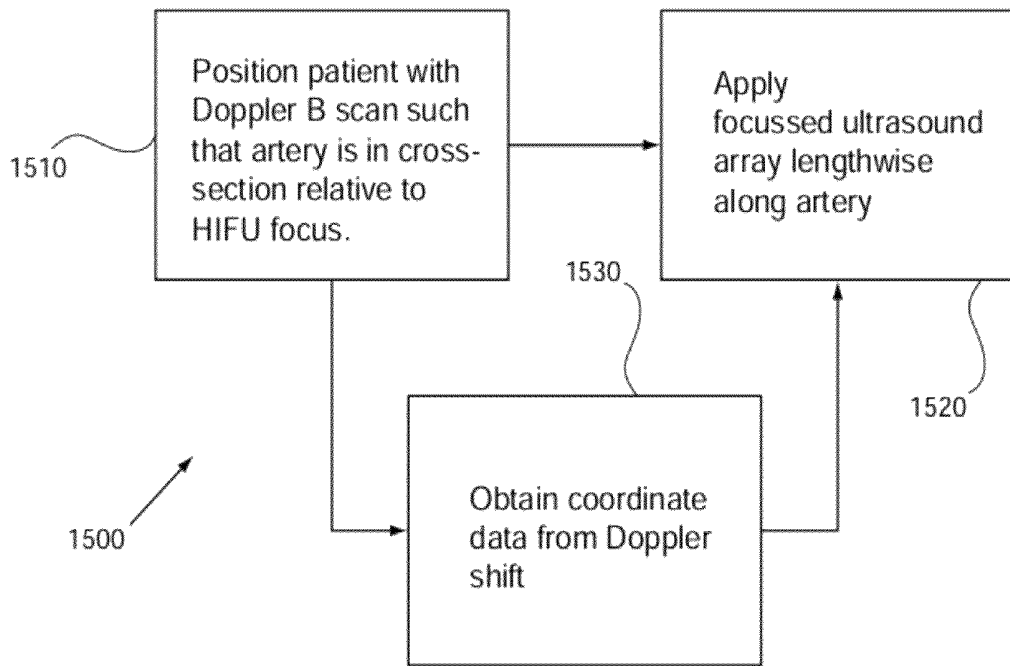

FIG. 17D

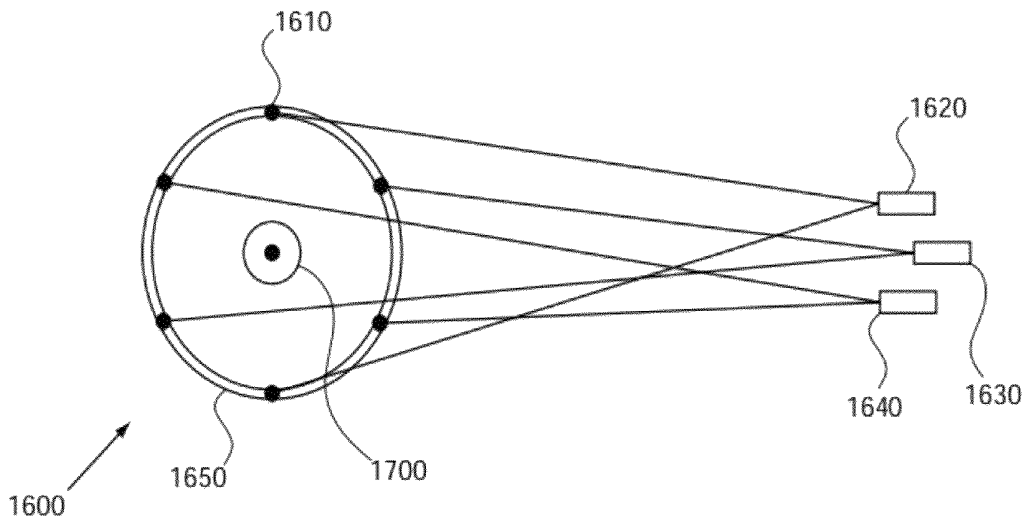

FIG. 17E

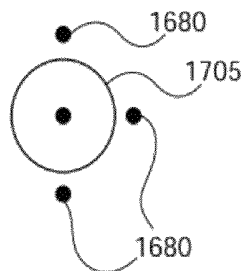

FIG. 17F

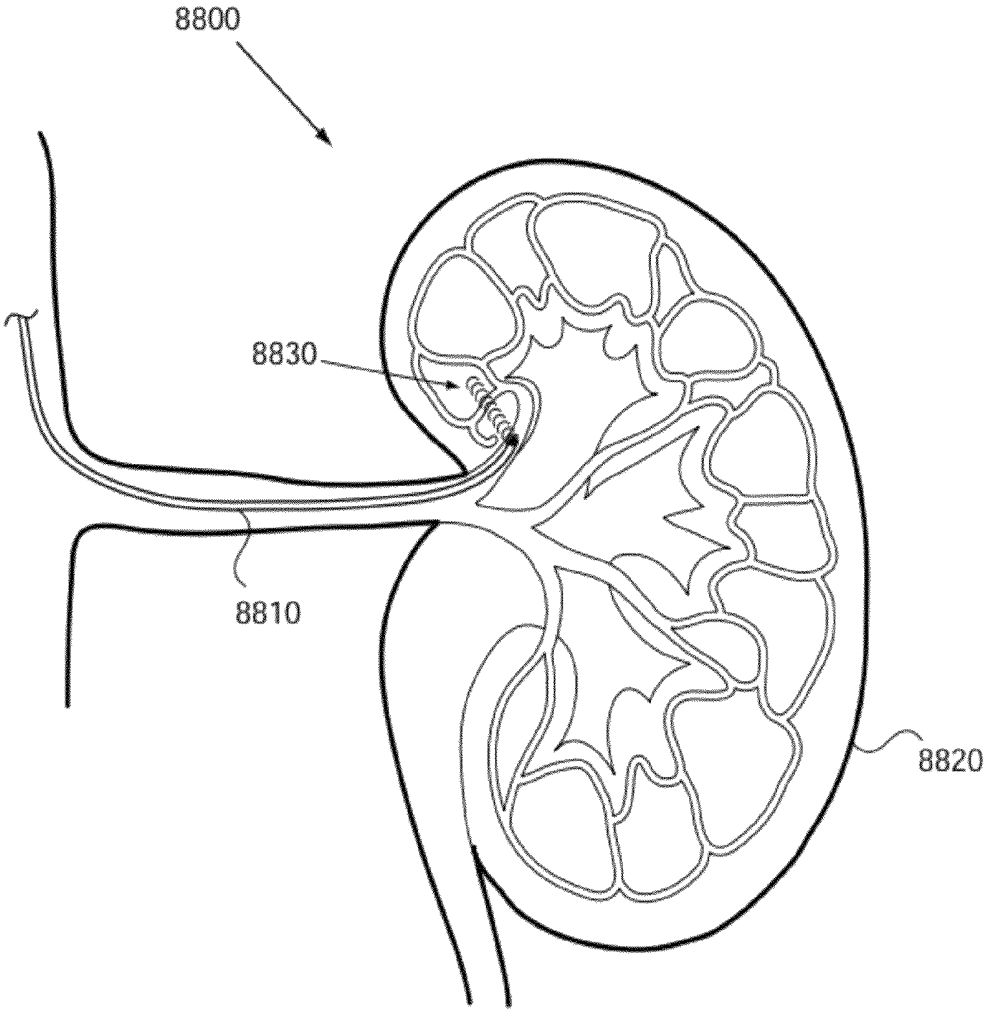

FIG. 18

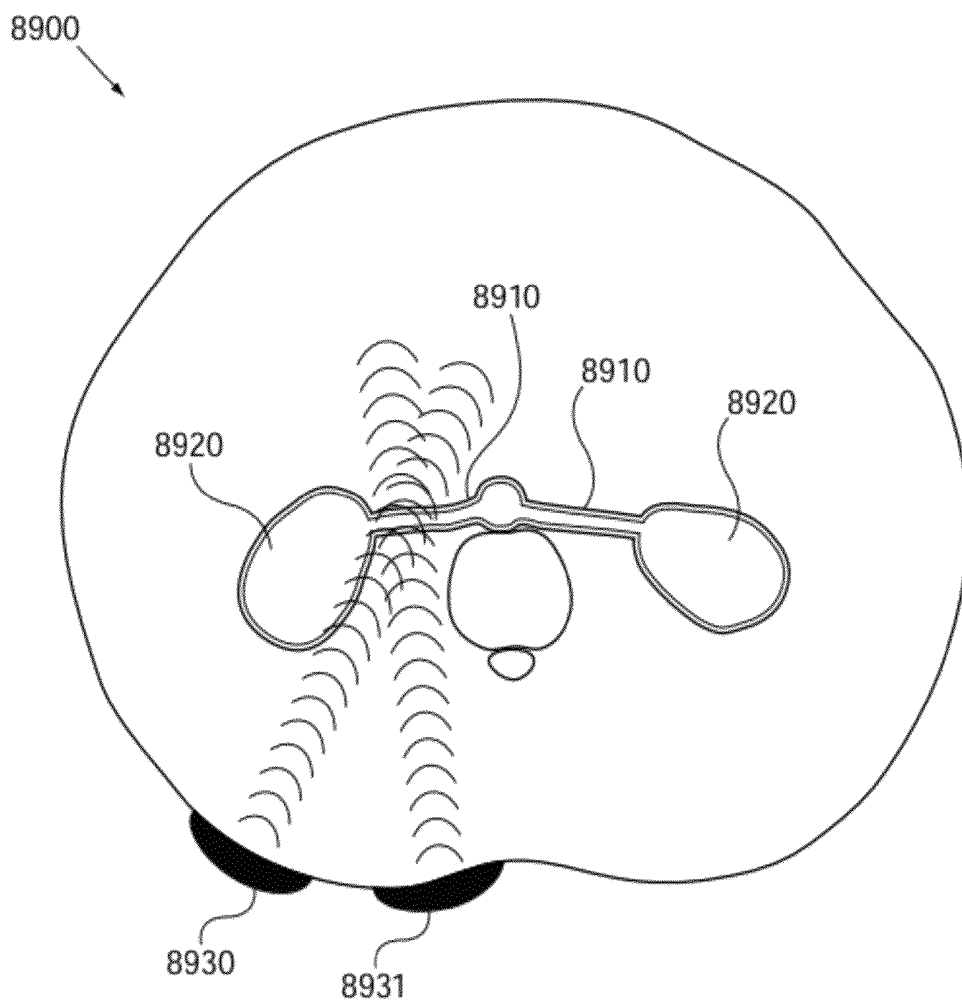

FIG. 19A

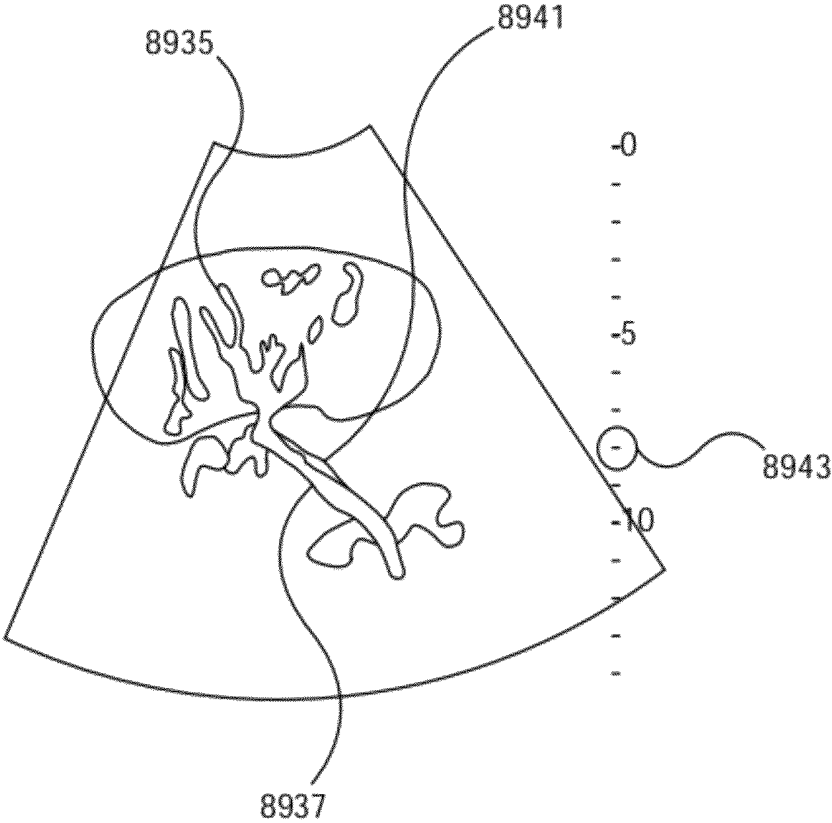

FIG. 19B

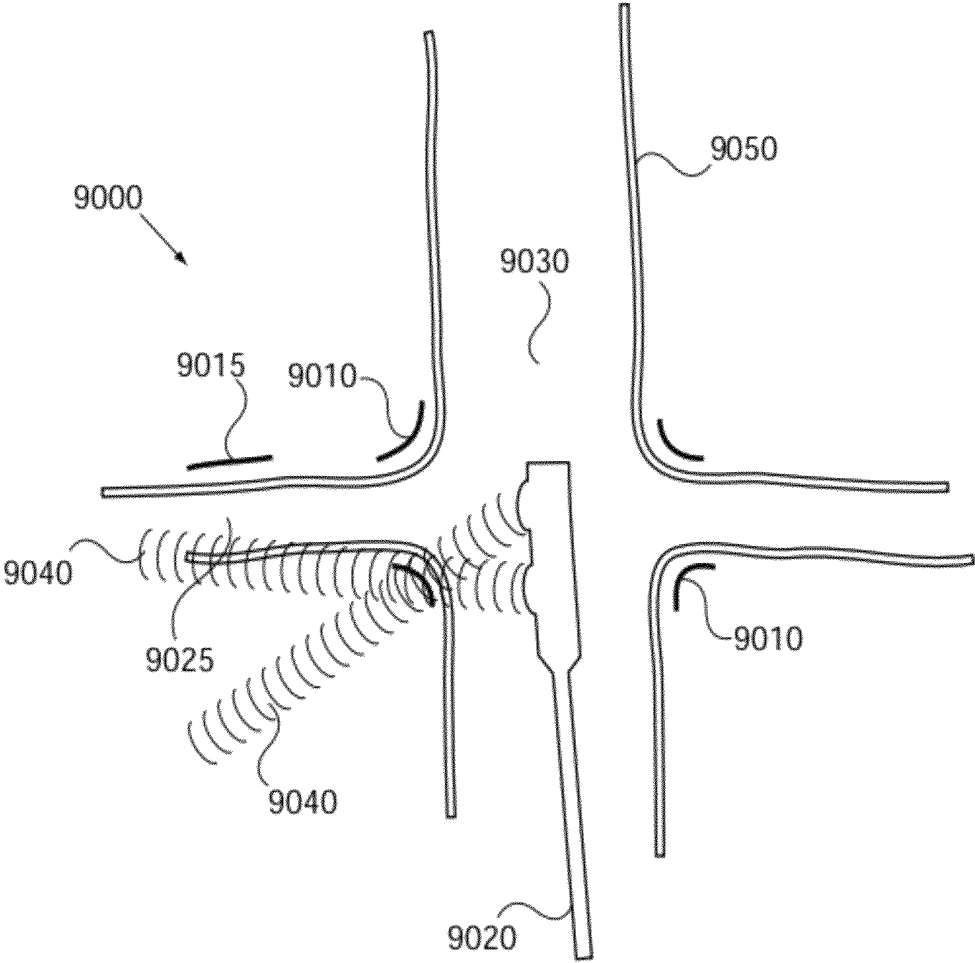

FIG. 20

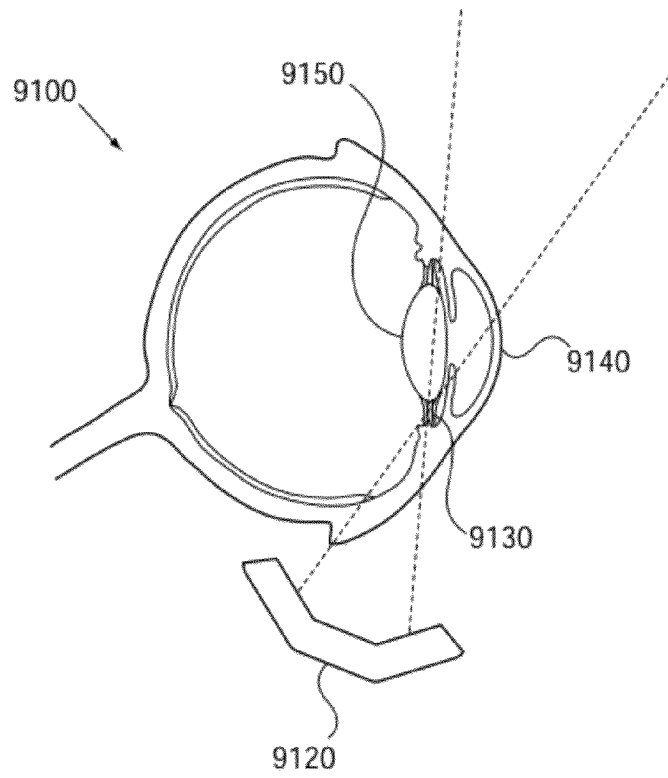

FIG. 21A

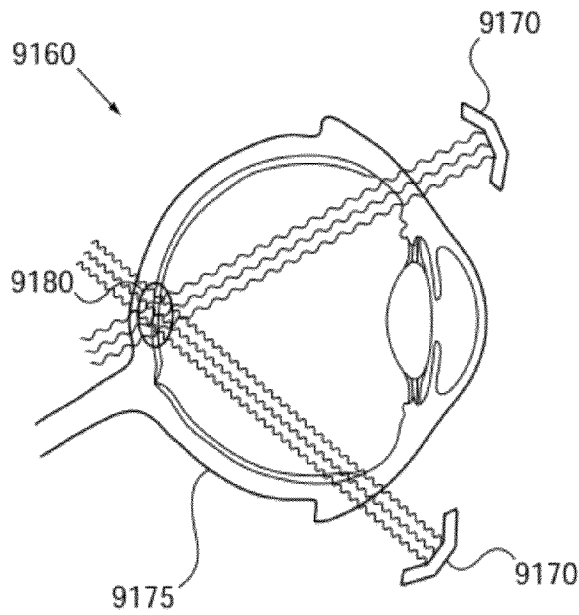

FIG. 21B

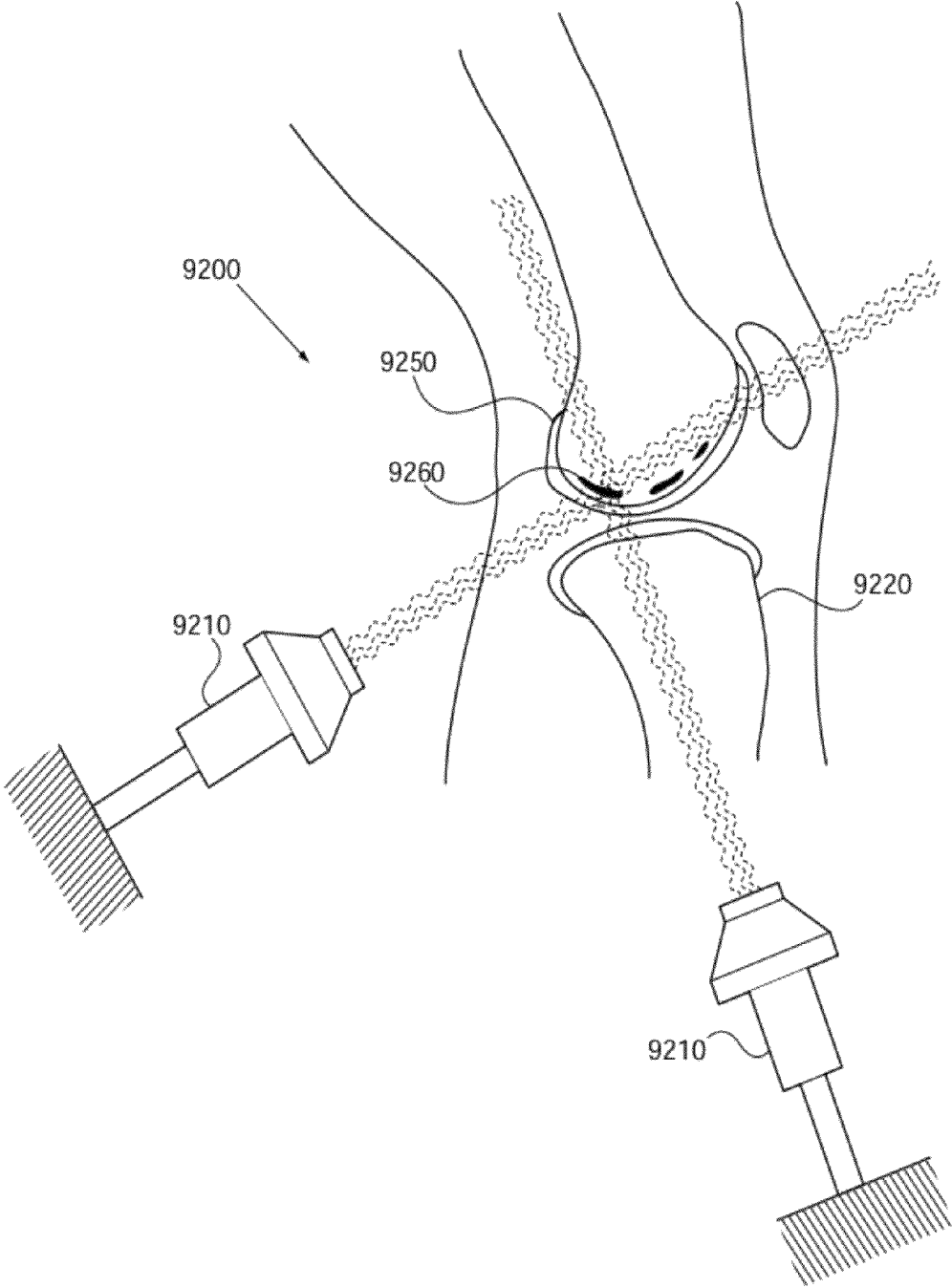

FIG. 22

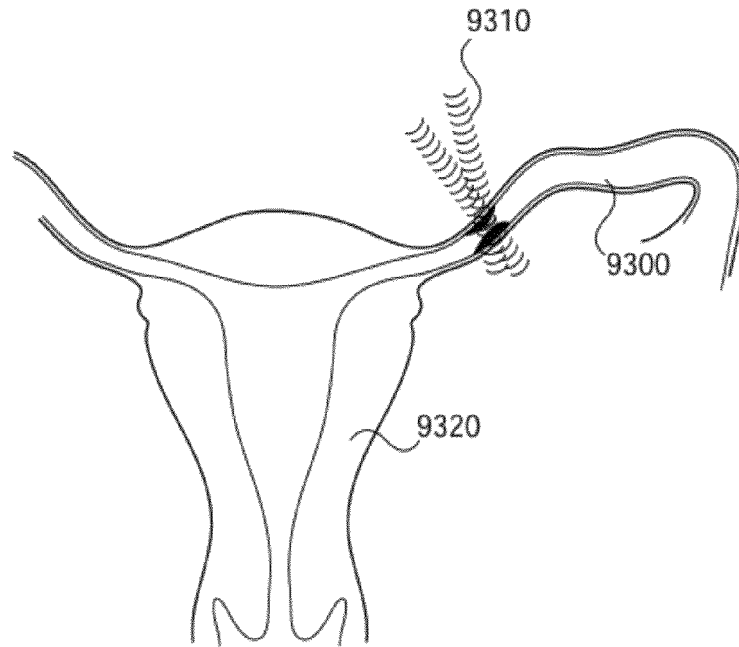

FIG. 23A

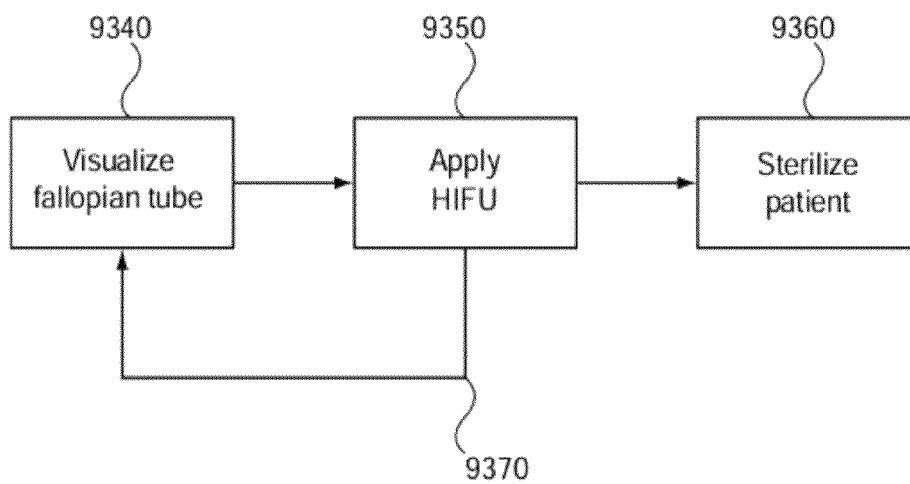

FIG. 23B

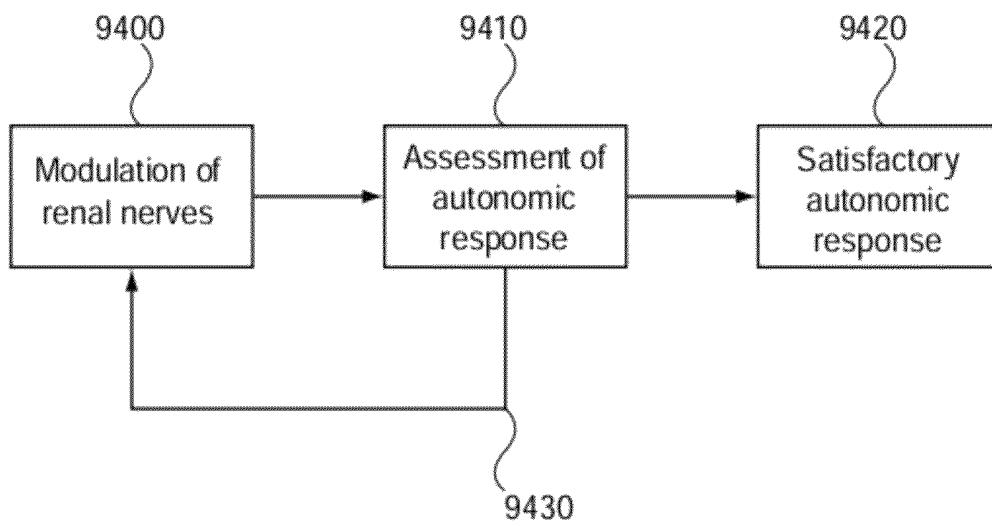

FIG. 24

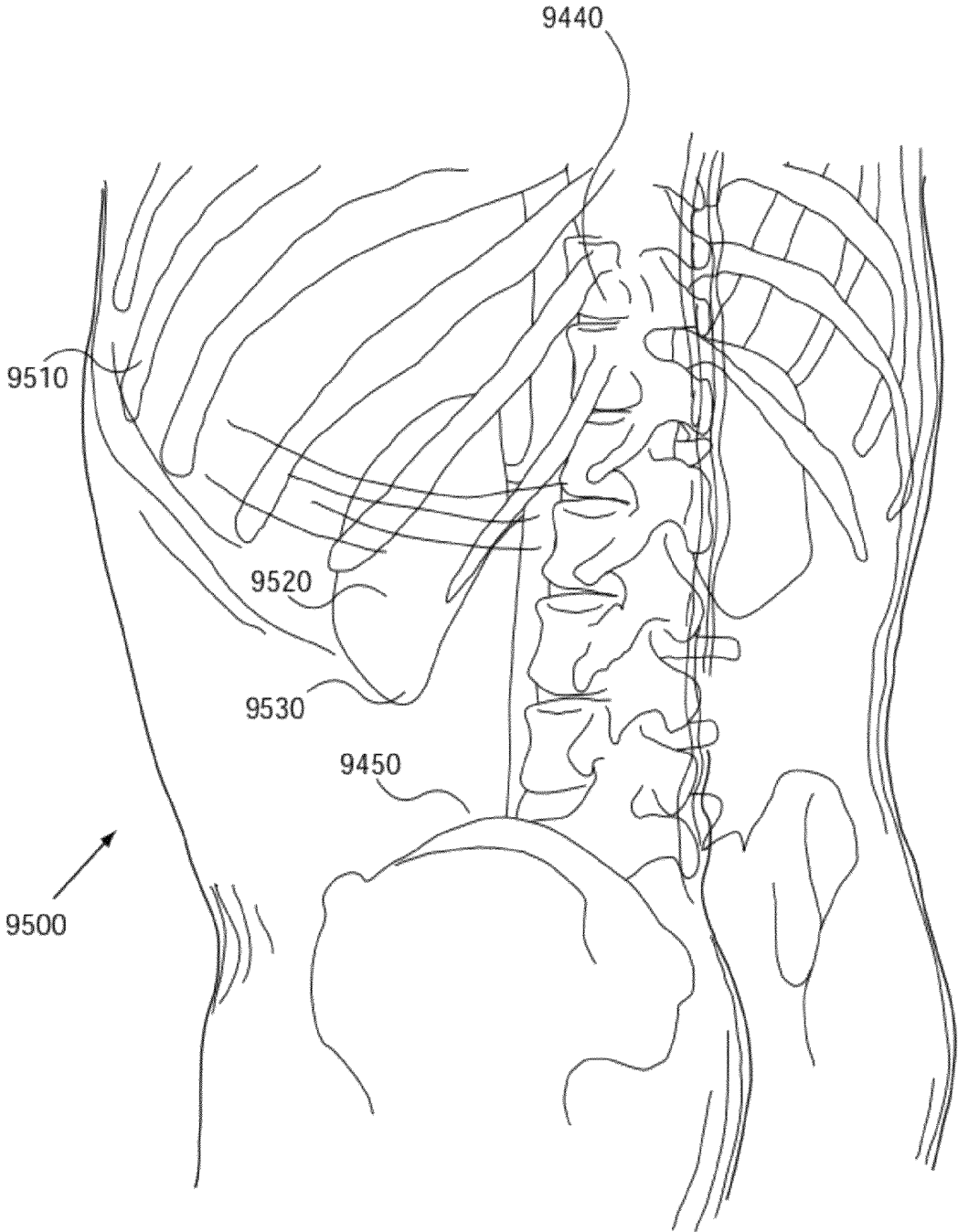

FIG. 25

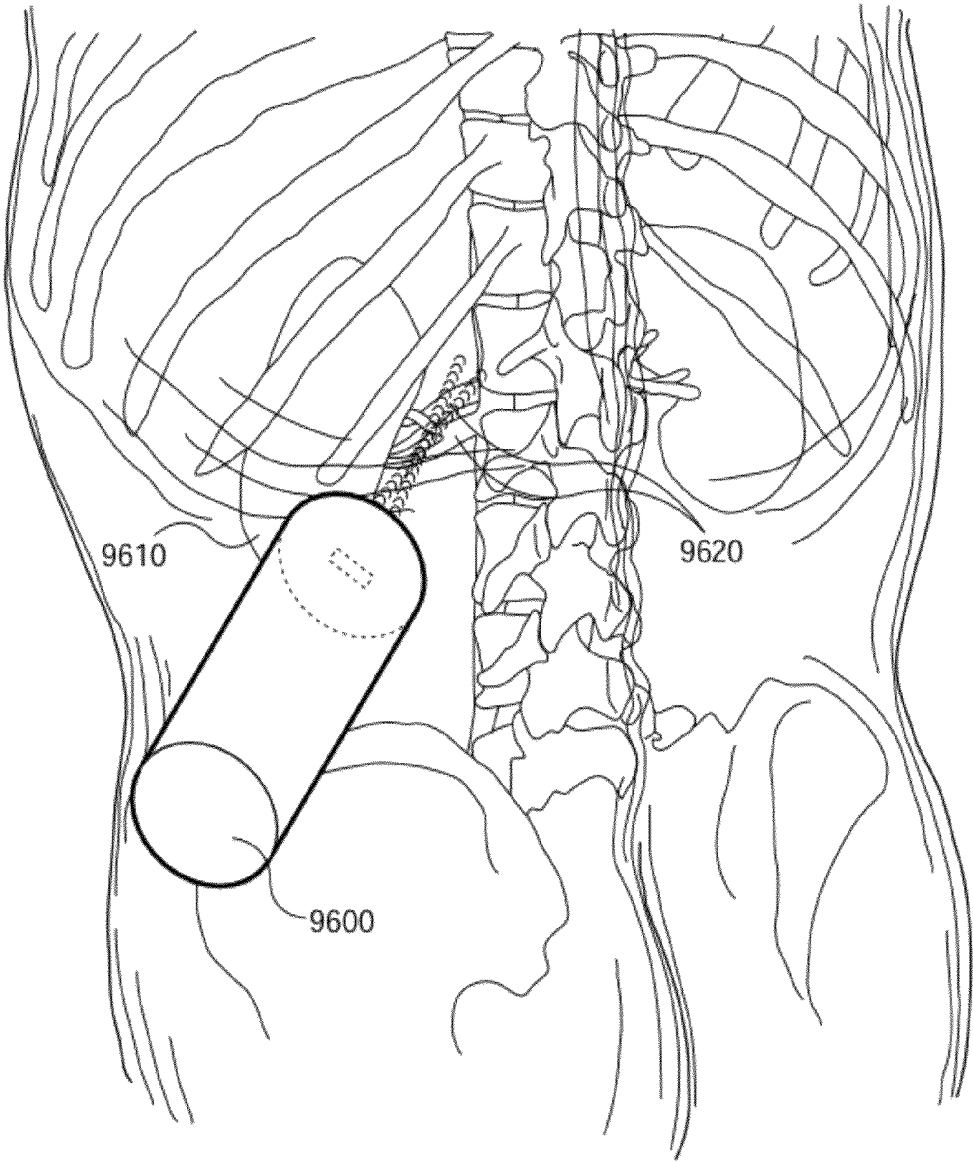

FIG. 26A

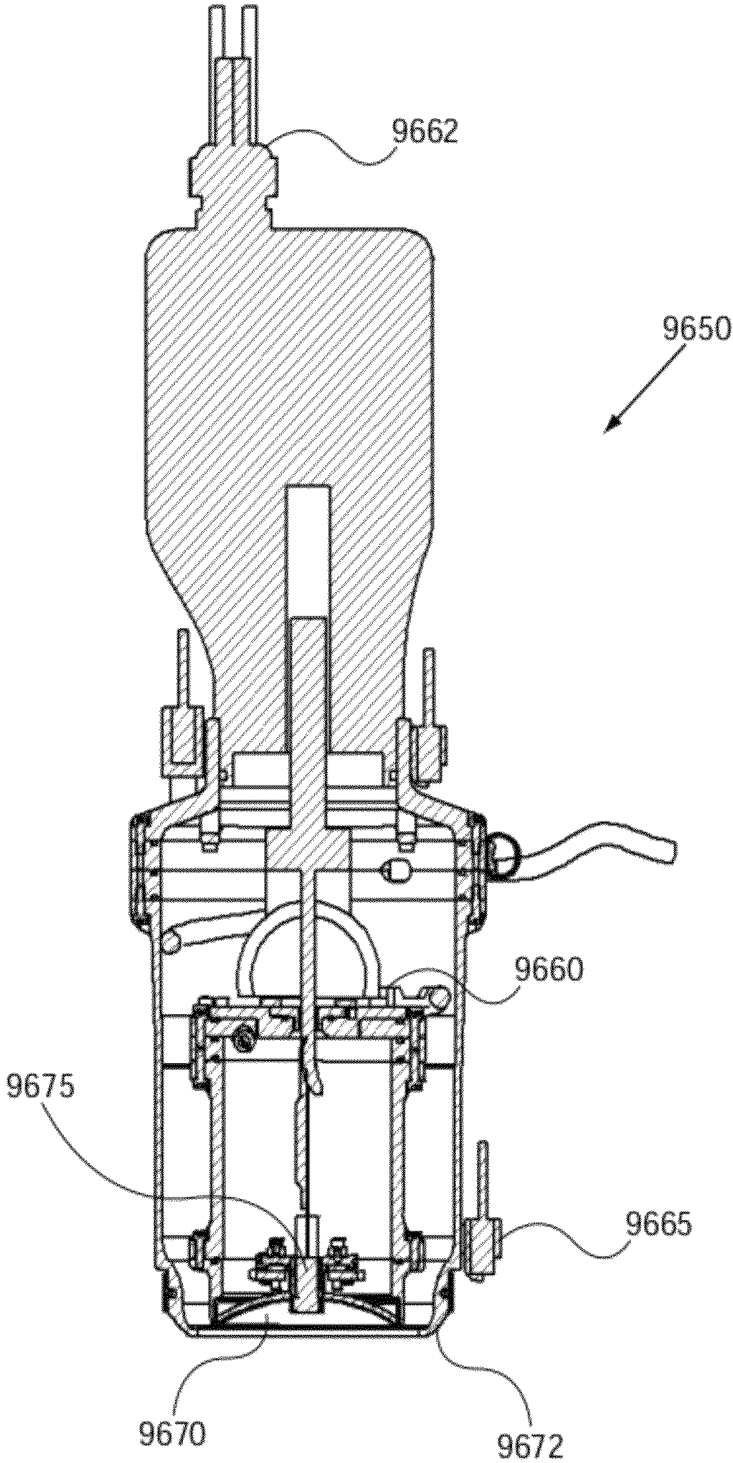

FIG. 26B

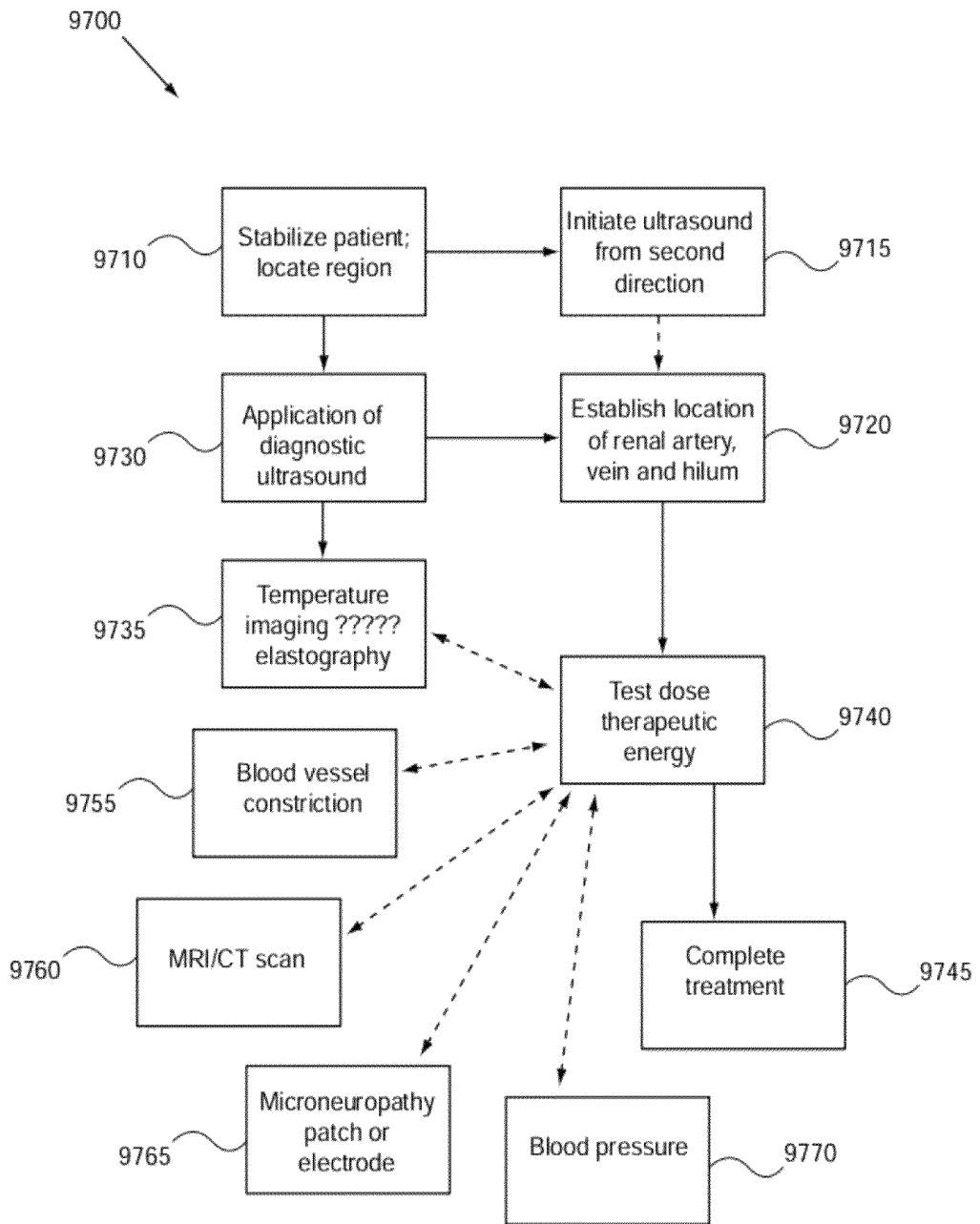

FIG. 27

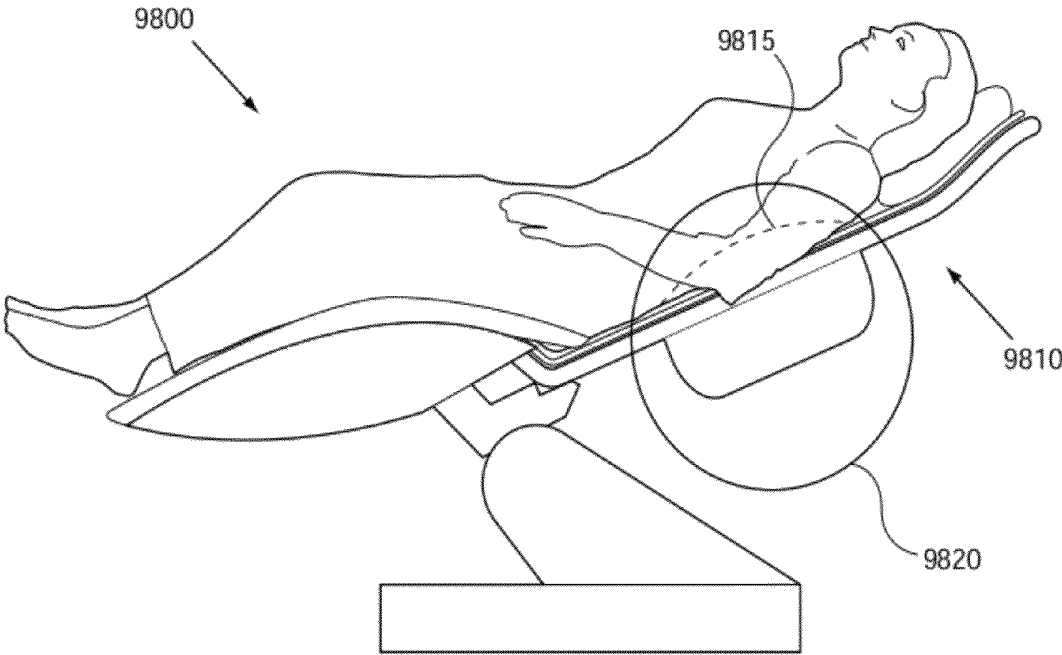

FIG. 28A

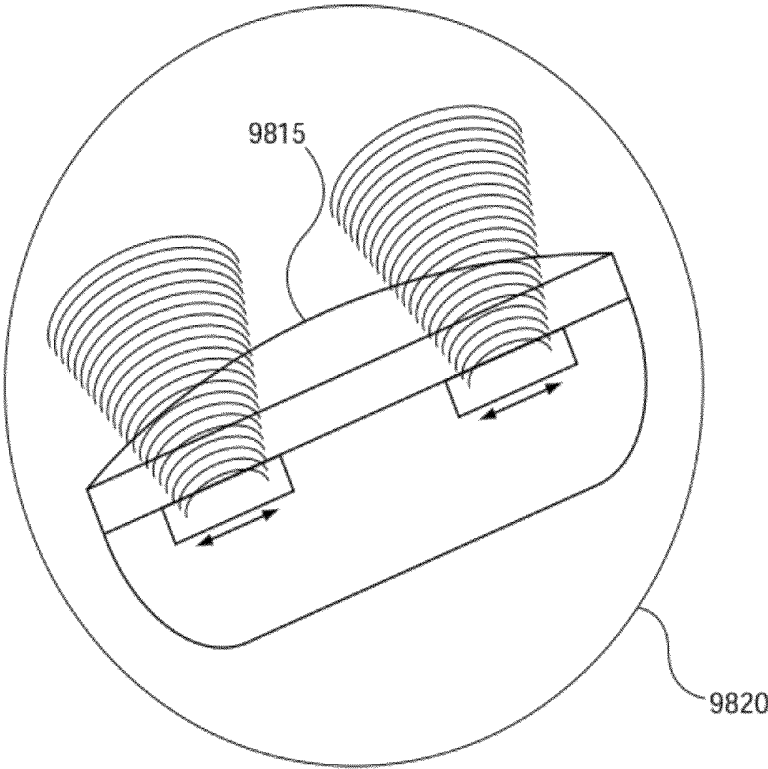

FIG. 28B

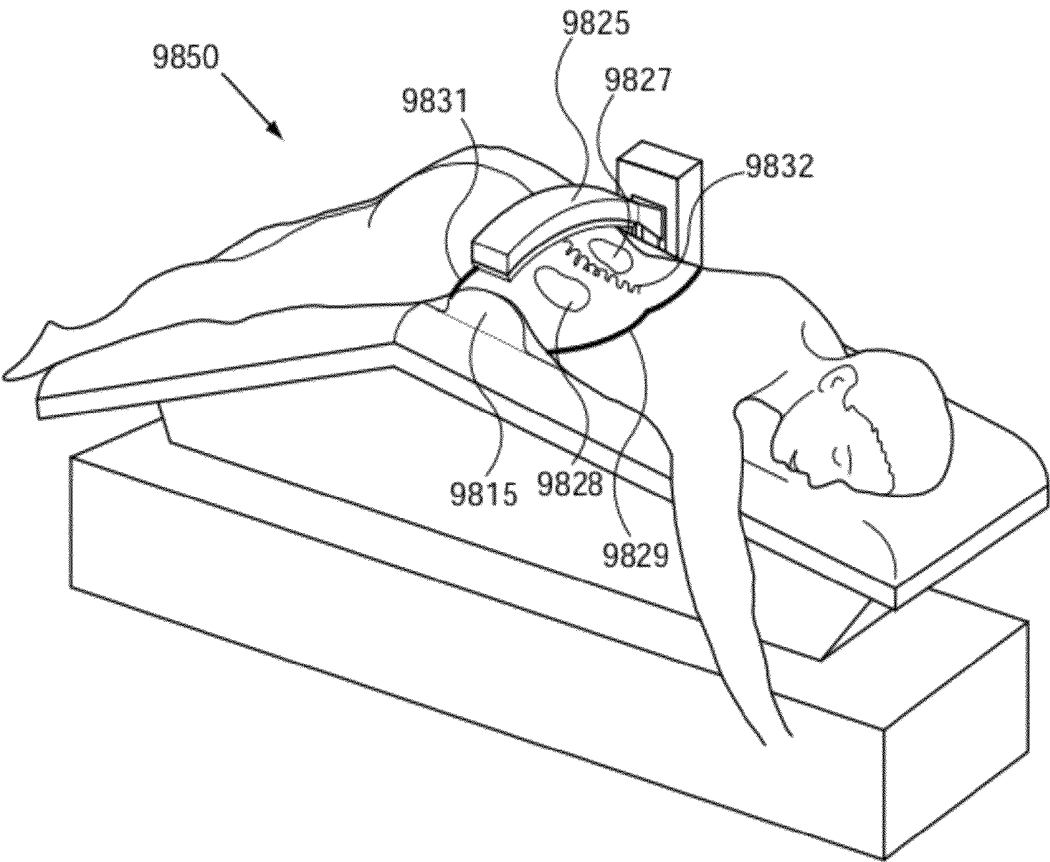

FIG. 28C

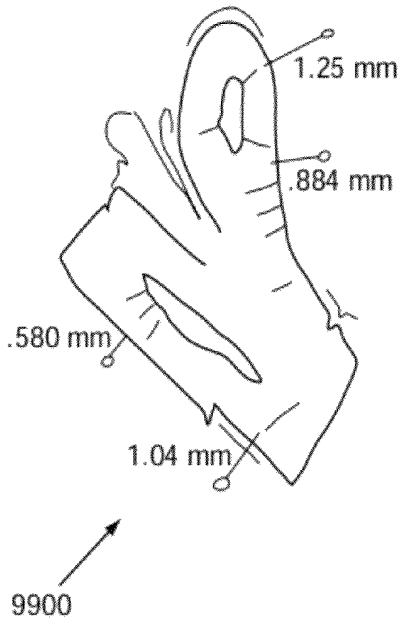

FIG. 29A

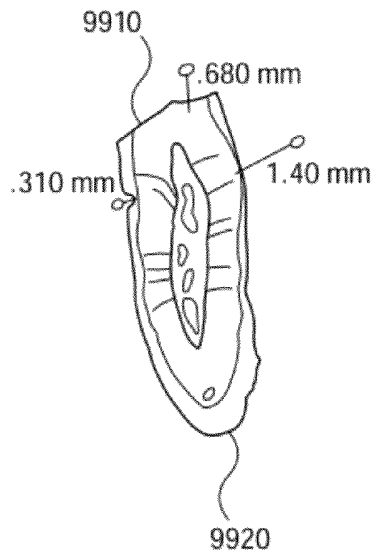

FIG. 29B

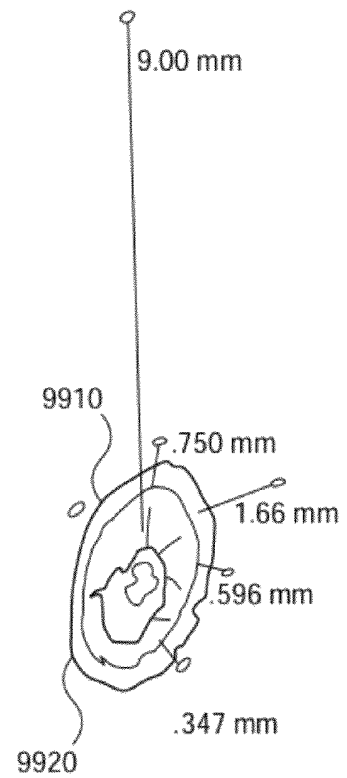

FIG. 29C

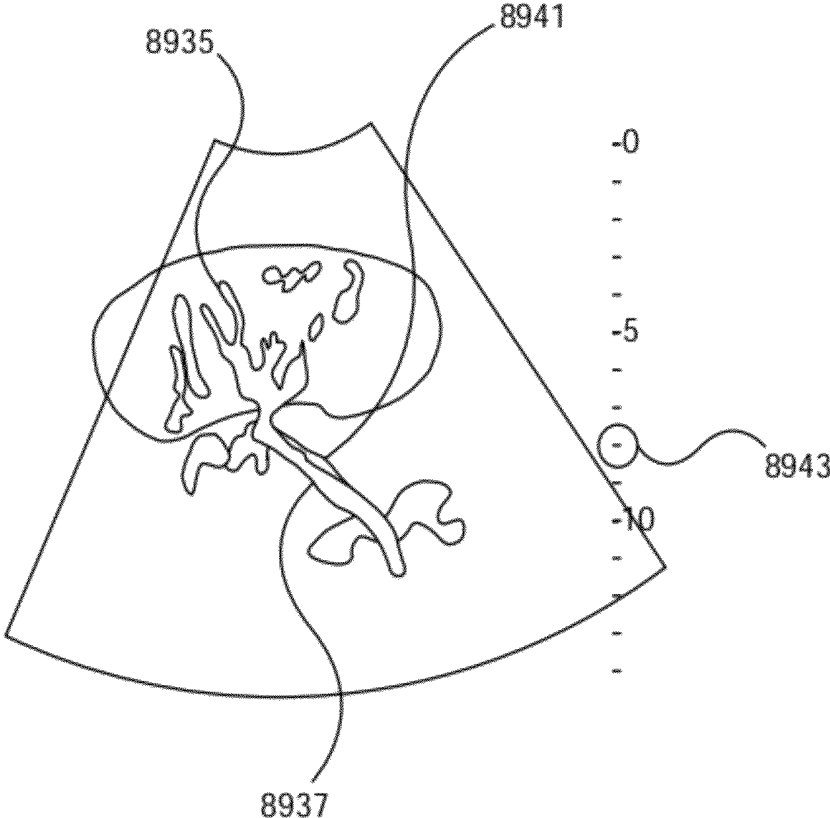

FIG. 29D

Target skin region

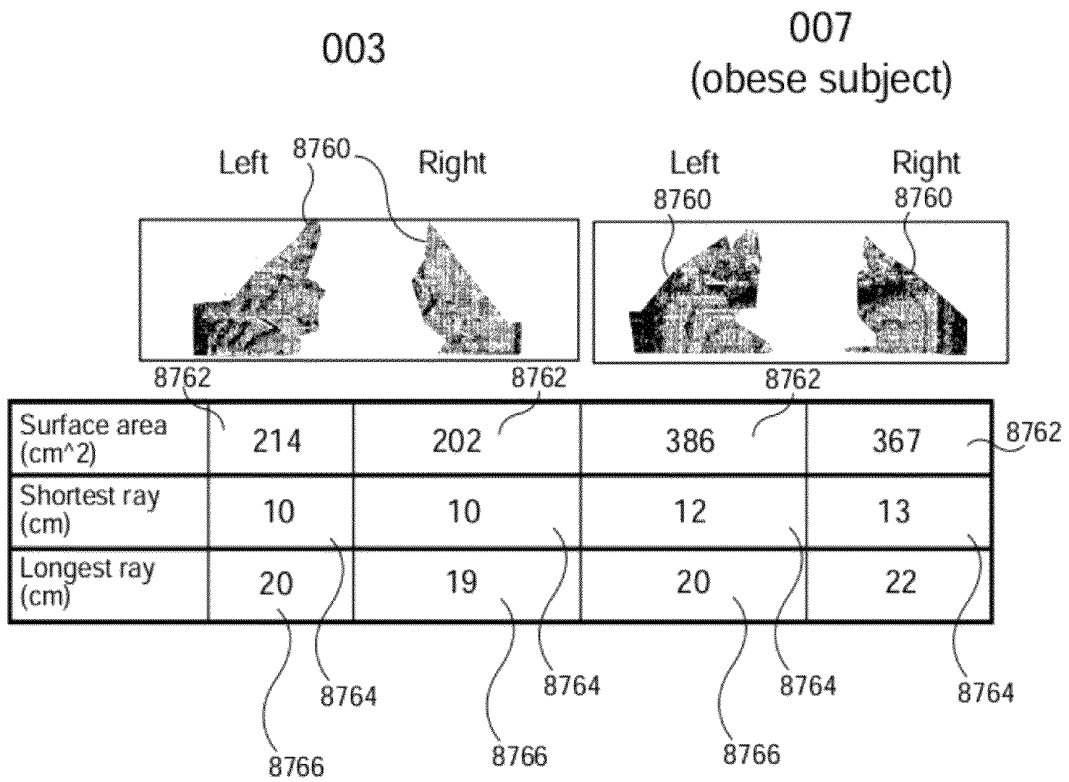

FIG. 29E

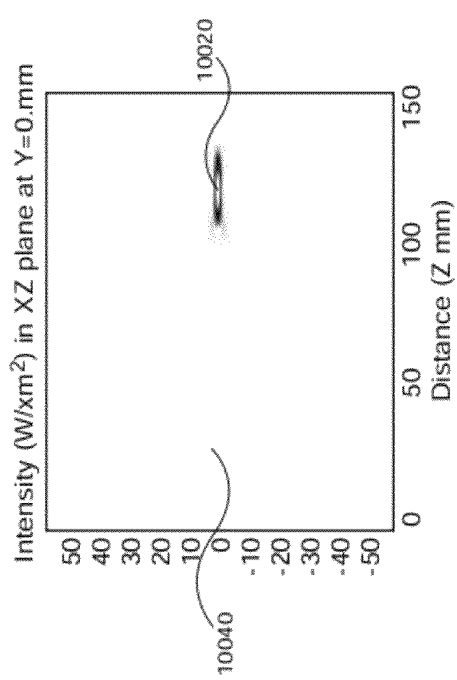

FIG. 30B

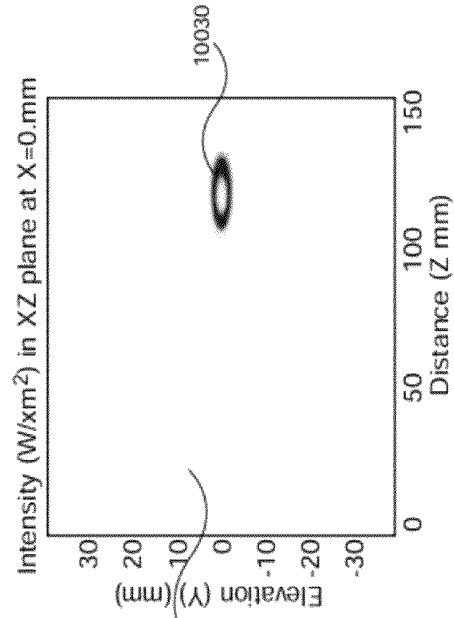

FIG. 30C

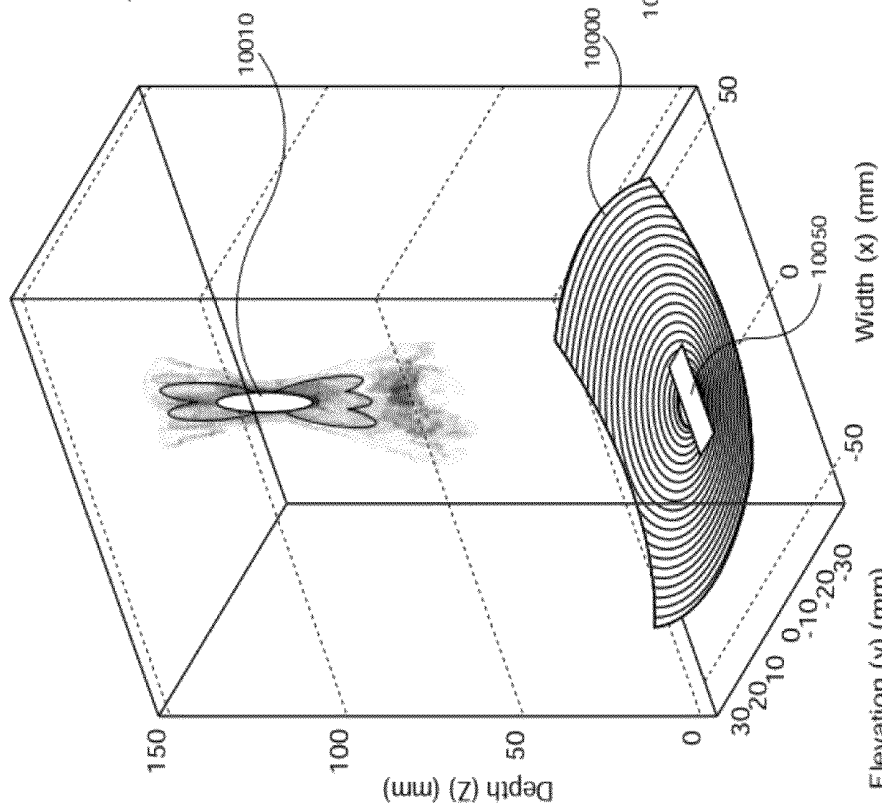

FIG. 30A

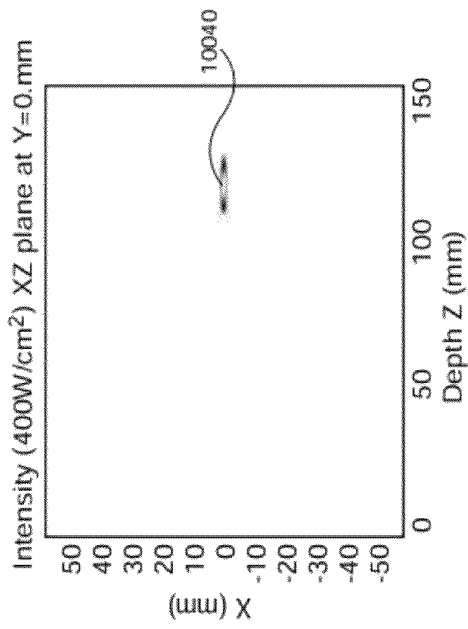

FIG. 30E

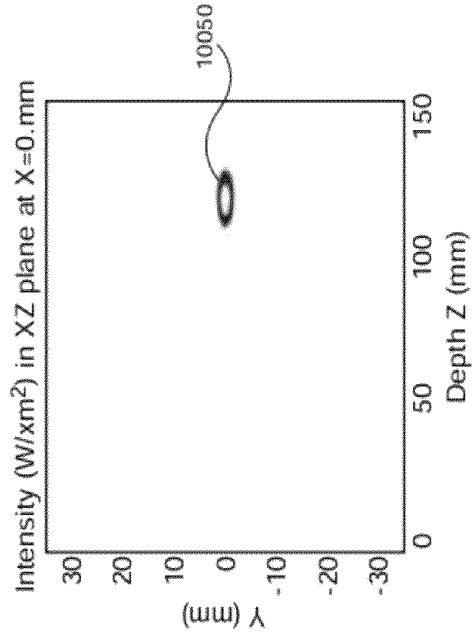

FIG. 30F

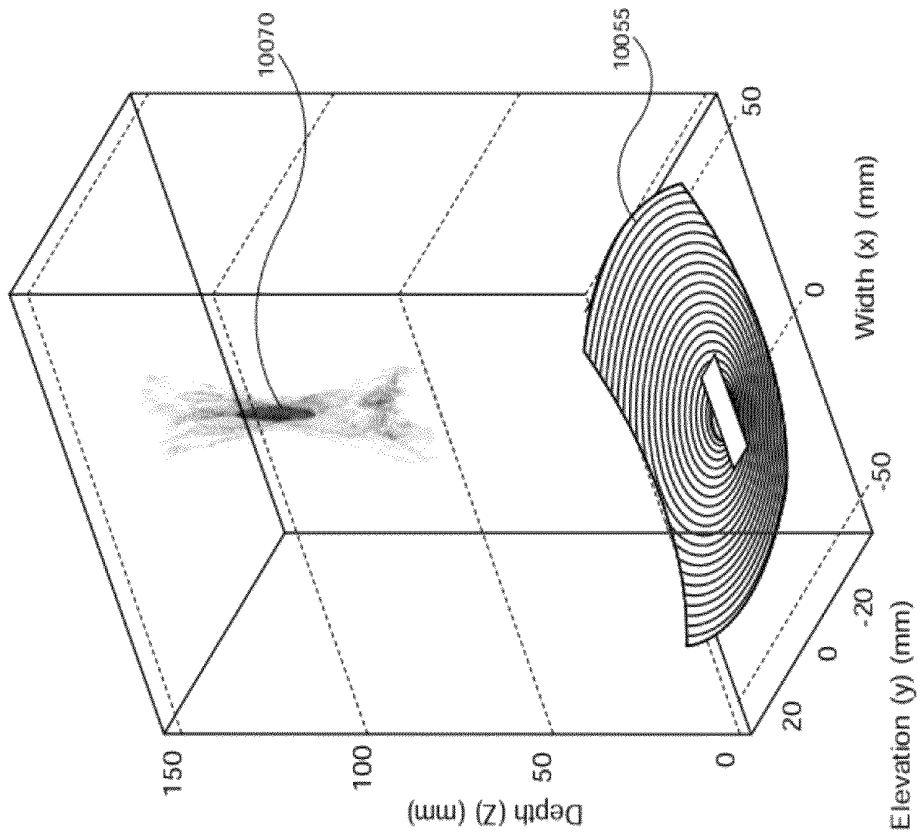

FIG. 30D

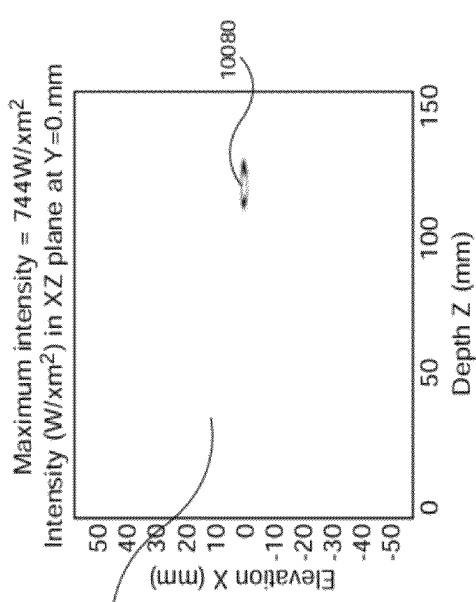

FIG. 30H

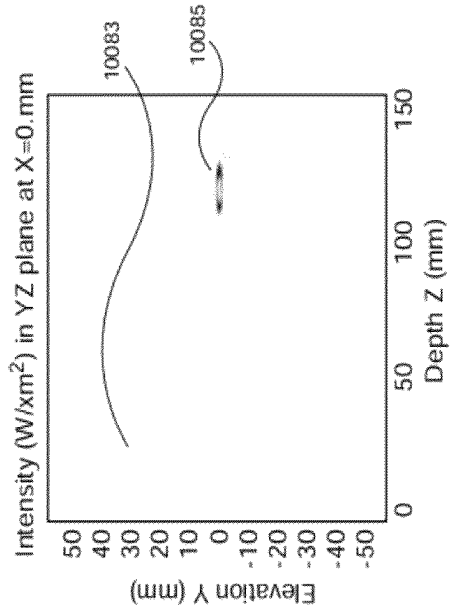

FIG. 30I

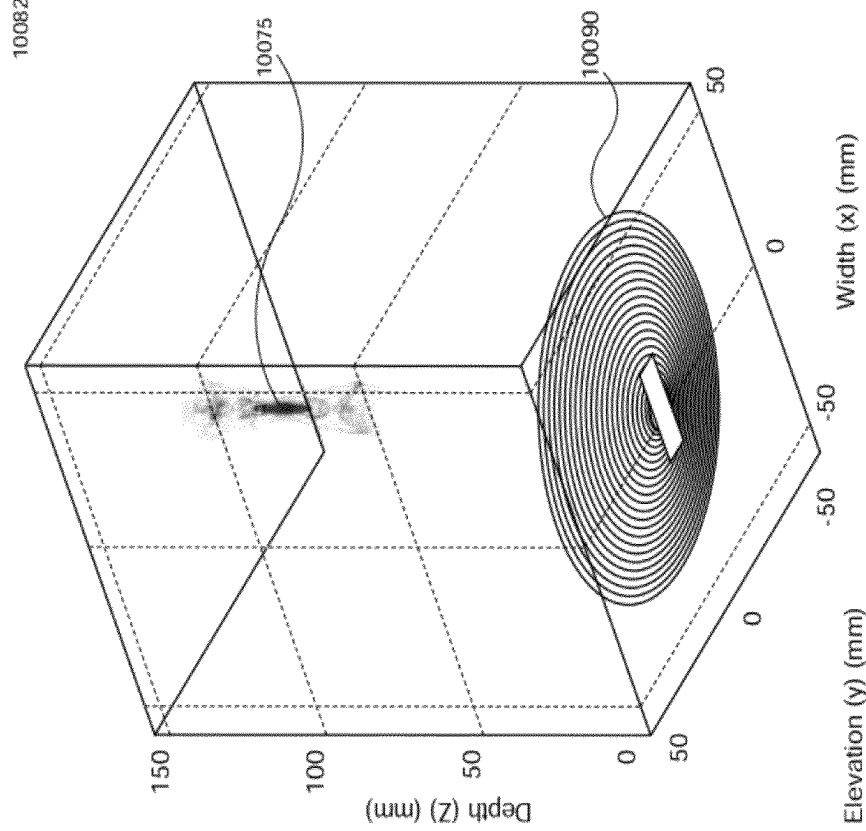

FIG. 30G

**INTRAVASCULAR CATHETER TO DELIVER
UNFOCUSED ENERGY TO NERVES
SURROUNDING A BLOOD VESSEL**

PRIORITY DATA

This applications is a continuation of U.S. patent application Ser. No. 12/902,133, filed Oct. 11, 2010, pending, which claims priority to and the benefit of U.S. Provisional patent application 61/377,908 filed Aug. 27, 2010, now lapsed, and U.S. Provisional patent application 61/347,375 filed May 21, 2010, now lapsed, and is a continuation-in-part of U.S. patent application Ser. No. 12/725,450 filed Mar. 16, 2010, now pending, which is a continuation-in-part of U.S. patent application Ser. No. 12/685,655, filed on Jan. 11, 2010, now pending, which claims priority to and the benefit of U.S. Provisional Patent Application No. 61/256,983 filed Oct. 31, 2009, now lapsed, U.S. Provisional Patent Application No. 61/250,857 filed Oct. 12, 2009, now lapsed, U.S. Provisional Patent Application No. 61/261,741 filed Nov. 16, 2009, now lapsed, and U.S. Provisional Patent Application No. 61/291,359 filed Dec. 30, 2009, now lapsed.

U.S. patent application Ser. No. 12/725,450 also claims priority to, and the benefit of U.S. Provisional Patent Application No. 61/303,307 filed Feb. 10, 2010, now lapsed, U.S. Provisional Patent Application No. 61/256,983 filed Oct. 31, 2009, now lapsed, U.S. Provisional Patent Application No. 61/250,857 filed Oct. 12, 2009, now lapsed, U.S. Provisional Patent Application No. 61/261,741 filed Nov. 16, 2009, now lapsed, and U.S. Provisional Patent Application No. 61/291,359 filed Dec. 30, 2009, now lapsed.

The disclosures of all of the above referenced applications are expressly incorporated by reference herein.

The following patent applications are also expressly incorporated by reference herein.

U.S. patent application Ser. Nos. 11/583,569, 12/762,938, 11/583,656, 12/247,969, 10/633,726, 09/721,526, 10/780,405, 09/747,310, 12/202,195, 11/619,996, 09/696,076, 11/016,701, 12/887,178, 12/390,975, 12/887,178, 12/887,211, 12/887,232

It should be noted that the subject matters of the above applications and any other applications referenced herein are expressly incorporated into this application as if they are expressly recited in this application. Thus, in the instance where the references are not specifically labeled as "incorporated by reference" in this application, they are in fact deemed described in this application.

BACKGROUND

Energy delivery from a distance involves transmission of energy waves to affect a target at a distance. It allows for more efficient delivery of energy to targets and a greater cost efficiency and technologic flexibility on the generating side. For example, cellular phones receive targets from towers close to the user and the towers communicate with one another over a long range; this way, the cell phones can be low powered and communicate over a relatively small range yet the network can quickly communicate across the world. Similarly, electricity distribution from large generation stations to the users is more efficient than the users themselves looking for solutions.

In terms of treating a patient, delivering energy over a distance affords great advantages as far as targeting accuracy, technologic flexibility, and importantly, limited invasiveness into the patient. In a simple form, laparoscopic surgery has replaced much of the previous open surgical procedures and

lead to creation of new procedures and devices as well as a more efficient procedural flow for disease treatment. Laparoscopic tools deliver the surgeon's energy to the tissues of the patient from a distance and results in improved imaging of the region being treated as well as the ability for many surgeons to visualize the region at the same time.

Perhaps the most important aspect is the fact that patients have much less pain, fewer complications, and the overall costs of the procedures are lower. Visualization is improved as is the ability to perform tasks relative to the visualization.

Continued advances in computing, miniaturization and economization of energy delivery technologies, and improved imaging will lead to still greater opportunities to apply energy from a distance into the patient and treat disease.

SUMMARY

In some embodiments, procedures and devices are provided, which advance the art of medical procedures involving transmitted energy to treat disease. The procedures and devices follow along the lines of: 1) transmitting energy to produce an effect in a patient from a distance; 2) allowing for improved imaging or targeting at the site of treatment; 3) creating efficiencies through utilization of larger and more powerful devices from a position of distance from or within the patient as opposed to attempting to be directly in contact with the target as a surgeon, interventional cardiologist or radiologist might do. In many cases, advanced visualization and localization tools are utilized as well.

In some embodiments, a method of treatment includes placing an energy source outside a patient, operating the energy source so that an energy delivery path of the energy source is aimed towards a nerve inside the patient, wherein the nerve is a part of an autonomic nervous system, and using the energy source to deliver treatment energy from outside the patient to the nerve located inside the patient to treat the nerve.

In some embodiments, the treatment energy comprises focused energy.

In some embodiments, the treatment energy comprises non-focused energy.

In some embodiments, the treatment energy comprises HIFU energy.

In some embodiments, the treatment energy comprises LIFU energy.

In some embodiments, the treatment energy is delivered to the nerve to achieve partial ablation of the nerve.

In some embodiments, the treatment energy is delivered to the nerve to achieve complete ablation of the nerve.

In some embodiments, the treatment energy is delivered to achieve paralysis of the nerve.

In some embodiments, the nerve leads to a kidney.

In some embodiments, the nerve comprises a renal nerve.

In some embodiments, the nerve comprises a sympathetic nerve connected to the kidney.

In some embodiments, the nerve comprises an afferent nerve connected to the kidney.

In some embodiments, the nerve comprises a renal sympathetic nerve at a renal pedicle.

In some embodiments, the nerve comprises a nerve trunk adjacent to a vertebra.

In some embodiments, the nerve comprises a ganglion adjacent to a vertebra.

In some embodiments, the nerve comprises a dorsal root nerve.

In some embodiments, the nerve leads to an adrenal gland.

In some embodiments, the nerve comprises a motor nerve.

In some embodiments, the nerve is next to a kidney.

In some embodiments, the nerve is behind an eye.

In some embodiments, the nerve comprises a celiac plexus.

In some embodiments, the nerve is within or around a vertebral column.

In some embodiments, the nerve extends to a facet joint.

In some embodiments, the nerve comprises a celiac ganglion.

In some embodiments, the act of operating the energy source comprises positioning the energy source.

In some embodiments, the energy source comprises an ultrasound energy source.

In some embodiments, the ultrasound energy source is used to deliver the treatment energy to the nerve from multiple directions outside the patient.

In some embodiments, the treatment energy is delivered to modulate the nerve without damaging the nerve.

In some embodiments, the method further includes determining a position of a renal vessel using an imaging device located outside the patient.

In some embodiments, the position of the renal vessel is used to determine a position of the nerve.

In some embodiments, the imaging device comprises a CT device, an MRI device, a thermography device, an infrared imaging device, an optical coherence tomography device, a photoacoustic imaging device, a PET imaging device, a SPECT imaging device, or an ultrasound device.

In some embodiments, the method further includes determining a position of the nerve inside the patient.

In some embodiments, the act of determining the position of the nerve inside the patient comprises determining a position of a renal vessel to target the nerve that surrounds the renal vessel.

In some embodiments, the renal vessel comprises a renal artery.

In some embodiments, the act of determining the position of the nerve inside the patient comprises using a Doppler triangulation technique.

In some embodiments, the imaging device comprises a MRI device.

In some embodiments, the imaging device comprises a CT device.

In some embodiments, the treatment energy comprises HIFU energy, and the imaging device comprises a MRI device.

In some embodiments, the treatment energy comprises HIFU energy, and the imaging device comprises an ultrasound device.

In some embodiments, the nerve leads to a kidney, and the imaging device comprises a MRI device.

In some embodiments, the nerve leads to a kidney, and the imaging device comprises an ultrasound device.

In some embodiments, the nerve leads to a kidney, and the imaging device is used to obtain a doppler signal.

In some embodiments, the treatment energy is delivered to a kidney to decrease a sympathetic stimulus to the kidney, decrease an afferent signal from the kidney to an autonomic nervous system, or both.

In some embodiments, the method further includes delivering testing energy to the patient to determine if there is a reaction resulted therefrom, wherein the testing energy is delivered before the treatment energy is delivered from the energy source.

In some embodiments, the testing energy comprises heat or vibratory energy, and the method further comprises performing a test to detect sympathetic nerve activity.

In some embodiments, the testing energy comprises a stimulus applied to a skin, and the method further comprises detecting an output from the patient.

In some embodiments, the output comprises a heart rate.

In some embodiments, the test energy is delivered to stimulate a baroreceptor complex, and the method further includes applying pressure to a carotid artery, and determining whether a blood pressure decreases after application of the pressure to the carotid artery.

In some embodiments, the test energy is delivered using an ultrasound device that is placed outside the patient.

In some embodiments, the treatment energy from the energy source is delivered if the blood pressure decreases or if the blood pressure decreases at a rate that is above a pre-scribed threshold.

In some embodiments, the treatment energy is delivered to treat hypertension.

In some embodiments, the treatment energy is delivered to treat glaucoma.

In some embodiments, the energy source is operated so that the energy source aims at a direction that aligns with a vessel that is next to the nerve.

In some embodiments, the method further includes tracking a movement of a treatment region containing the nerve.

In some embodiments, the energy delivery path of the energy source is aimed towards the nerve by using a position of a blood vessel that is surrounded by the nerve.

In some embodiments, the method further includes delivering a device inside the patient, and using the device to determine a position of the nerve inside the patient, wherein the energy source is operated based at least in part on the determined position so that the energy delivery path is aimed towards the nerve.

In some embodiments, the device is placed inside a vessel that is surrounded by the nerve, and the position of the nerve is determined indirectly by determining a position of the vessel.

In some embodiments, a system for treatment includes an energy source for placement outside a patient, wherein the energy source is configured to aim an energy delivery path towards a nerve that is a part of an autonomic nervous system inside the patient, and wherein the energy source is configured to deliver treatment energy from outside the patient to the nerve located inside the patient to treat the nerve.

In some embodiments, the energy source is configured to provide focused energy.

In some embodiments, the energy source is configured to provide non-focused energy.

In some embodiments, the energy source is configured to provide HIFU energy.

In some embodiments, the energy source is configured to provide LIFU energy.

In some embodiments, the energy source is configured to provide the treatment energy to achieve partial ablation of the nerve.

In some embodiments, the energy source is configured to deliver the treatment energy to achieve complete ablation of the nerve.

In some embodiments, the energy source is configured to deliver the treatment energy to achieve paralysis of the nerve.

In some embodiments, the energy source comprises an ultrasound energy source.

In some embodiments, the ultrasound energy source is configured to deliver the treatment energy to the nerve from multiple directions outside the patient while the ultrasound energy source is stationary relative to the patient.

In some embodiments, the energy source is configured to deliver the treatment energy to modulate the nerve without damaging tissues that are within a path of the treatment energy to the nerve.

In some embodiments, the nerve comprises a renal nerve, and the system further includes a processor located outside the patient, wherein the processor is configured for receiving an input related to a position of a renal artery, determining an output related to a position of the renal nerve based on a model that associates artery position with nerve position, and providing the output to a positioning system for the energy source so that the positioning system can cause the energy source to deliver the treatment energy from the outside of the patient to the renal nerve to treat the renal nerve.

In some embodiments, the system further includes a processor for determining a position of a renal vessel located outside the patient.

In some embodiments, the system further includes an imaging device for providing an image signal, wherein the processor is configured to determine the position based on the image signal.

In some embodiments, the imaging device comprises a CT device, a MRI device, a thermography device, an infrared imaging device, an optical coherence tomography device, a photoacoustic imaging device, a PET imaging device, a SPECT imaging device, or an ultrasound device.

In some embodiments, the position of the renal vessel is used during the treatment energy delivery to target the nerve that surrounds the renal vessel.

In some embodiments, the position is determined using a Doppler triangulation technique.

In some embodiments, the renal vessel comprises a renal artery.

In some embodiments, treatment energy is delivered to a kidney to decrease a sympathetic stimulus to the kidney, decrease an afferent signal from the kidney to an autonomic nervous system, or both.

In some embodiments, the energy source is also configured to deliver testing energy to the patient to determine if there is a reaction resulted therefrom.

In some embodiments, the energy source is configured to deliver the treatment energy to treat hypertension.

In some embodiments, the energy source is configured to deliver the treatment energy to treat glaucoma.

In some embodiments, the energy source has an orientation so that the energy source aims at a direction that aligns with a vessel that is next to the nerve.

In some embodiments, the energy source is configured to track a movement of the nerve.

In some embodiments, the energy source is configured to track the movement of the nerve by tracking a movement of a blood vessel next to the nerve.

In some embodiments, the energy source is configured to aim at the nerve by aiming at a vessel that is surrounded by the nerve.

In some embodiments, the system further includes a device for placement inside the patient, and a processor for determining a position using the device, wherein the energy source is configured to aim the energy delivery path towards the nerve inside the patient based at least in part on the determined position.

In some embodiments, the device is sized for insertion into a vessel that is surrounded by the nerve.

In some embodiments, a system to deliver energy from a position outside a skin of a patient to a nerve surrounding a blood vessel inside the patient, includes a processor configured to receive image signal, and determine a three dimensional coordinate of a blood vessel based on the image signal, and an energy source configured to deliver energy from the position outside the skin of the patient to the nerve surrounding the blood vessel, wherein the processor is also configured to control the energy source based on the determined coordinate.

In some embodiments, the system further includes an imaging device for providing the image signal.

In some embodiments, the imaging device comprises a MRI device.

In some embodiments, the imaging device comprises an ultrasound device.

In some embodiments, the energy comprises focused energy.

In some embodiments, the energy comprises focused ultrasound.

In some embodiments, the energy source comprises an ultrasound array that is aligned with the vessel.

In some embodiments, the system further includes an imaging device for providing a B-mode ultrasound for imaging the blood vessel.

In some embodiments, a system to deliver energy from a position outside a skin of a patient to a nerve surrounding a blood vessel includes a fiducial for placement inside the blood vessel, a detection device to detect the fiducial inside the blood vessel, a processor configured to determine a three dimensional coordinate of the detected fiducial, and an energy source configured to transmit energy through the skin and to focus the energy at the region of the blood vessel, wherein the processor is configured to operate the energy source based on the determined three dimensional coordinate of the fiducial, and information regarding the blood vessel.

In some embodiments, the energy source comprises an ultrasound device, and wherein the blood vessel is a renal artery.

In some embodiments, the system further includes an ultrasound imaging system.

In some embodiments, the fiducial is placed inside the blood vessel and is attached to an intravascular catheter.

In some embodiments, the fiducial is a passive fiducial that is configured to respond to an external signal.

In some embodiments, the fiducial is an active fiducial, transmitting its position to the detection device.

In some embodiments, a method to treat hypertension in a patient includes obtaining an imaging signal from a blood vessel in the patient, planning a delivery of energy to a wall of the blood vessel, and delivering energy from outside a skin of the patient to an autonomic nerve surrounding the blood vessel.

In some embodiments, the method further includes selectively modulating an afferent nerve within a sympathetic nerve bundle.

In some embodiments, the method further includes utilizing microneurography after the delivery of the energy to determine an effect of the energy delivery on a sympathetic nervous system.

In some embodiments, the blood vessel extends to or from a kidney, and the method further comprises locating the blood vessel with doppler ultrasound.

In some embodiments, a system to modulate an autonomic nerve in a patient utilizing transcutaneous energy delivery, the system includes a processor comprising an input for receiving information regarding energy and power to be delivered to a treatment region containing the nerve, and an output for outputting a signal, wherein the processor is configured to determine a position of a reference target from outside the patient to localize the nerve relative to the reference target, a ther-

peutic energy device comprising a transducer for delivering energy from outside the patient, a controller to control an aiming of the transducer based at least in part on the signal from the processor, and an imaging system coupled to the processor or the therapeutic energy device.

In some embodiments, the processor is configured to determine the position during an operation of the therapeutic energy device.

In some embodiments, the system further includes a patient interface configured to position the therapeutic device so that the transducer is aimed toward a blood vessel connected to a kidney from a position between ribs superiorly, a iliac crest inferiorly, and a vertebral column medially.

In some embodiments, the therapeutic energy device is configured to deliver focused ultrasound.

In some embodiments, the reference target is at least a portion of a blood vessel traveling to or from a kidney, and the nerve is a renal nerve.

In some embodiments, the transducer is configured to focus energy at a distance from 6 cm to 18 cm.

In some embodiments, the transducer is configured to deliver the energy in a form of focused ultrasound to a renal blood vessel at an angle ranging between about -10 degrees and about -48 degrees relative to a horizontal line connecting transverse processes of a spinal column.

In some embodiments, the energy from the therapeutic energy device ranges between 100 W/cm^2 and 2500 W/cm^2 .

In some embodiments, the reference target is an indwelling vascular catheter.

In some embodiments, the imaging system is a magnetic resonance imaging system and the therapeutic energy device is an ultrasound device.

In some embodiments, the imaging system is an ultrasound imaging system.

In some embodiments, the processor is a part of the therapeutic energy device.

In some embodiments, the processor is a part of the imaging system.

In some embodiments, a method to deliver energy from a position outside the skin of a patient to a nerve surrounding a blood vessel, includes placing a device inferior to ribs, superior to an iliac crest, and lateral to a spine, and using the device to maintain an energy delivery system at a desired position relative to the patient so that the energy delivery system can deliver energy through the skin without traversing bone.

In some embodiments, the energy delivery system comprises a focused ultrasound delivery system.

In some embodiments, a device for use in a system to deliver focused ultrasound energy from a position outside a skin of a patient to a nerve surrounding a blood vessel, includes a positioning device configured to maintain an energy delivery system at a desired position relative to the patient so that the energy delivery system can deliver energy through the skin without traversing bone, wherein the positioning device is configured to be placed inferior to ribs, superior to an iliac crest, and lateral to a spine.

In some embodiments, the energy delivery system comprises a focused ultrasound delivery system.

In some embodiments, the positioning device is configured to maintain an angle of the focused ultrasound delivery system such that bony structures are not include in an ultrasound field.

In some embodiments, a system for treatment includes a treatment device configured to deliver energy from outside a patient to a nerve inside the patient, a catheter configured for placement inside a vessel surrounded by the nerve, the catheter configured to transmit a signal, and a processor config-

ured to receive the signal and determine a reference position in the vessel, wherein the treatment device is configured deliver the energy to the nerve based on the determined reference position.

5 In some embodiments, the treatment device comprises an ultrasound device.

In some embodiments, a method of inhibiting the function of a nerve traveling with an artery includes providing an external imaging modality to determine the location of the artery of a patient, placing the artery in a first three dimensional coordinate reference based on the imaging, placing or associating a therapeutic energy generation source in the first three dimensional coordinate reference frame, modeling the delivery of energy to the adventitial region of the artery or a region adjacent to the artery where a nerve travels, delivering therapeutic energy from the therapeutic energy source, from at least two different angles, through the skin of a patient, to intersect at the artery or the region adjacent to the artery, and at least partially inhibiting the function of the nerve traveling with the artery.

In some embodiments, the imaging modality is one of: ultrasound, MRI, and CT.

25 In some embodiments, the therapeutic energy is ultrasound.

In some embodiments, the artery is a renal artery.

In some embodiments, placing the artery in a three dimensional reference frame comprises locating the artery using a doppler ultrasound signal.

30 In some embodiments, the method further includes utilizing a fiducial wherein the fiducial is placed internal to the patient.

In some embodiments, said fiducial is temporarily placed in a position internal to the patient.

In some embodiments, said fiducial is a catheter placed in the artery of the patient.

In some embodiments, said catheter is detectable using a radiofrequency signal and said imaging modality is ultrasound.

40 In some embodiments, the therapeutic energy from the energy source is delivered in a distribution along the length of the artery.

In some embodiments, the therapeutic energy is ionizing radiation.

In some embodiments, a system to inhibit the function of a nerve traveling with a renal artery includes a detector to determine the location of the renal artery and renal nerve from a position external to a patient, an ultrasound component to deliver therapeutic energy through the skin from at least two directions to the nerve surrounding the renal artery, a modeling algorithm comprising an input and an output, said input to the modeling algorithm comprising a three dimensional coordinate space containing a therapeutic energy source and the position of the renal artery in the three dimensional coordinate space, and said output from the modeling algorithm comprising the direction and energy level of the ultrasound component, a fiducial, locatable from a position outside a patient, adapted to be temporarily placed in the artery of the patient and communicate with the detector to determine the location of the renal artery in a three dimensional reference frame, the information regarding the location transmittable as the input to the model.

In some embodiments, the fiducial is a passive reflector of ultrasound.

65 In some embodiments, the fiducial generates radiofrequency energy.

In some embodiments, the fiducial is activated to transmit energy based on a signal from an ultrasound or magnetic field generator.

In some embodiments, the output from the model instructs the ultrasound component to deliver a lesion on the artery in which the major axis of the lesion is longitudinal along the length of the artery.

In some embodiments, the output from the model instructs the ultrasound component to deliver multiple lesions around an artery simultaneously.

In some embodiments, the output from the model instructs the ultrasound component to deliver a circumferential lesion around the artery.

In some embodiments, the lesion is placed around the renal artery just proximal to the bifurcation of the artery in the hilum of the kidney.

In some embodiments, a method to stimulate or inhibit the function of a nerve traveling to or from the kidney includes identifying an acoustic window at the posterior region of a patient in which the renal arteries can be visualized, transmitting a first energy through the skin of a patient from the posterior region of the patient, imaging an arterial region using the first transmitted energy, and applying a second transmitted energy to the arterial adventitia by coupling the imaging and the second transmitted energy.

In some embodiments, the method further includes tracking the image created by the first transmitted energy.

In some embodiments, a method to locate the position of a blood vessel in the body of a patient includes applying a first wave of ultrasound, from a first direction, to a region of a blood vessel from outside of the patient and detecting its return signal, comparing the applied first wave and its return signal, simultaneously, or sequentially, applying a second wave of ultrasound from a second direction to the blood vessel and detecting a its return signal, and integrating the return signals from the first wave and the return signals from the second wave to determine the position, in a three dimensional coordinate reference, of the blood vessel.

In some embodiments, the method further includes the step of instructing a therapeutic ultrasound transducer to apply energy to the position of the blood vessel.

DESCRIPTION OF FIGURES

FIGS. 1a-b depict the focusing of energy sources on nerves of the autonomic nervous system.

FIG. 1c depicts an imaging system to help direct the energy sources.

FIG. 2 depicts targeting and/or therapeutic ultrasound delivered through the stomach to the autonomic nervous system posterior to the stomach.

FIG. 3a depicts focusing of energy waves on the renal nerves.

FIG. 3b depicts a coordinate reference frame for the treatment.

FIG. 3C depicts targeting catheters placed in any of the renal vessels.

FIG. 3D depicts an image detection system of a blood vessel with a temporary fiducial placed inside.

FIG. 3E depicts a therapy paradigm for the treatment and assessment of hypertension.

FIG. 4a depicts the application of energy to the autonomic nervous system surrounding the carotid arteries.

FIG. 4B depicts the application of energy to through the vessels of the renal hilum.

FIGS. 5a-b depicts the application of focused energy to the autonomic nervous system of the eye.

FIG. 6 depicts the application of constricting lesions to the kidney deep inside the calyces of the kidney.

FIGS. 7a depicts a patient in an imaging system receiving treatment with focused energy waves.

FIG. 7b depicts visualization of a kidney being treated.

FIG. 7c depicts a close up view of the renal nerve region of the kidney being treated.

FIG. 7d depicts an algorithmic method to treat the autonomic nervous system using MRI and energy transducers.

FIG. 7e depicts a geometric model obtained from cross-sectional images of the area of the aorta and kidneys.

FIG. 7F depicts a close up image of the region of treatment.

FIG. 7G depicts the results of measurements from a series of cross sectional image reconstructions.

FIG. 7H depicts the results of measurements from a series of cross-sectional images from a patient in a more optimized position.

FIG. 7I depicts an algorithmic methodology to apply treatment to the hilum of the kidney and apply energy to the renal blood vessels.

FIG. 8a depicts a percutaneous approach to treating the autonomic nervous system surrounding the kidneys.

FIG. 8b depicts an intravascular approach to treating or targeting the autonomic nervous system.

FIG. 8c depicts a percutaneous approach to the renal hila using a CT scan and a probe to reach the renal blood vessels.

FIGS. 9a-c depicts the application of energy from inside the aorta to regions outside the aorta to treat the autonomic nervous system.

FIG. 10 depicts steps to treat a disease using HIFU while monitoring progress of the treatment as well as motion.

FIG. 11a depicts treatment of brain pathology using cross sectional imaging.

FIG. 11b depicts an image on a viewer showing therapy of the region of the brain being treated.

FIG. 11c depicts another view of a brain lesion as might be seen on an imaging device which assists in the treatment of the lesion.

FIG. 12 depicts treatment of the renal nerve region using a laparoscopic approach.

FIG. 13 depicts a methodology for destroying a region of tissue using imaging markers to monitor treatment progress.

FIG. 14 depicts the partial treatment of portions of a nerve bundle using converging imaging and therapy wave.

FIG. 15a-b depicts the application of focused energy to the vertebral column to treat various spinal pathologies including therapy of the spinal or intravertebral nerves.

FIG. 15c illustrates energy being delivered to a spinal region.

FIG. 16A depicts the types of lesions which are created around the renal arteries to affect a response.

FIG. 16B depicts a simulation of ultrasound around a blood vessel I support of FIG. 16A.

FIG. 16C depicts data from ultrasound energy applied to the renal blood vessels and the resultant change in norepinephrine levels.

FIG. 17A depicts the application of multiple transducers to treat regions of the autonomic nervous system at the renal hilum.

FIGS. 17B-C depict methods for using imaging to direct treatment of a specific region surrounding an artery as well as display the predicted lesion morphology.

FIG. 17D depicts a method for localizing HIFU transducers relative to Doppler ultrasound signals.

FIG. 17E depicts an arrangement of transducers relative to a target.

FIG. 17F depicts ablation zones in a multi-focal region in cross-section.

FIG. 18 depicts the application of energy internally within the kidney to affect specific functional changes at the regional level within the kidney.

FIG. 19A depicts the direction of energy wave propagation to treat regions of the autonomic nervous system around the region of the kidney hilum.

FIG. 19B depicts a schematic of a B mode ultrasound from a direction determined through experimentation to provide access to the renal hilum with HIFU.

FIG. 20 depicts the application of ultrasound waves through the wall of the aorta to apply a therapy to the autonomic nervous system.

FIG. 21A depicts application of focused energy to the ciliary muscles and processes of the anterior region of the eye.

FIG. 21B depicts the application of focused non-ablative energy to the back of the eye to enhance drug or gene delivery or another therapy such as ionizing radiation.

FIG. 22 depicts the application of focused energy to nerves surrounding the knee joint to affect nerve function in the joint.

FIGS. 23A-B depicts the application of energy to the fallopian tube to sterilize a patient.

FIG. 24 depicts an algorithm to assess the effect of the neural modulation procedure on the autonomic nervous system. After a procedure is performed on the renal nerves, assessment of the autonomic response is performed by, for example, simulating the autonomic nervous system in one or more places.

FIG. 25 depicts an optimized position of a device to apply therapy to internal nerves.

FIG. 26A depicts positioning of a patient to obtain parameters for system design.

FIG. 26B depicts a device design based on the information learned from feasibility studies.

FIG. 27 depicts a clinical paradigm for treating the renal nerves of the autonomic nervous system based on feasibility studies.

FIG. 28 A-C depicts a treatment positioning system for a patient incorporating a focused ultrasound system.

FIG. 29 A-D depicts results of studies applying focused energy to nerves surrounding arteries and of ultrasound studies to visualize the blood vessels around which the nerves travel.

FIG. 29E depicts the results of design processes in which the angle, length, and surface area from CT scans is quantified.

FIGS. 30A-I depicts results of simulations to apply focused ultrasound to the region of a renal artery with a prototype device design based on simulations.

DETAILED DESCRIPTION

Hypertension is a disease of extreme national and international importance. There are 80 million patients in the US alone who have hypertension and over 200 million in developed countries worldwide. In the United States, there are 60 million patients who have uncontrolled hypertension, meaning that they are either non-compliant or cannot take the medications because of the side effect profile. Up to 10 million people might have completely resistant hypertension in which they do not reach target levels no matter what the medication regimen. The morbidities associated with uncontrolled hypertension are profound, including stroke, heart attack, kidney failure, peripheral arterial disease, etc. A con-

venient and straightforward minimally invasive procedure to treat hypertension would be a very welcome advance in the treatment of this disease.

Congestive Heart Failure (“CHF”) is a condition which occurs when the heart becomes damaged and blood flow is reduced to the organs of the body. If blood flow decreases sufficiently, kidney function becomes altered, which results in fluid retention, abnormal hormone secretions and increased constriction of blood vessels. These results increase the workload of the heart and further decrease the capacity of the heart to pump blood through the kidneys and circulatory system.

It is believed that progressively decreasing perfusion of the kidneys is a principal non-cardiac cause perpetuating the downward spiral of CHF. For example, as the heart struggles to pump blood, the cardiac output is maintained or decreased and the kidneys conserve fluid and electrolytes to maintain the stroke volume of the heart. The resulting increase in pressure further overloads the cardiac muscle such that the cardiac muscle has to work harder to pump against a higher pressure. The already damaged cardiac muscle is then further stressed and damaged by the increased pressure. Moreover, the fluid overload and associated clinical symptoms resulting from these physiologic changes result in additional hospital admissions, poor quality of life, and additional costs to the health care system. In addition to exacerbating heart failure, kidney failure can lead to a downward spiral and further worsening kidney function. For example, in the forward flow heart failure described above, (systolic heart failure) the kidney becomes ischemic. In backward heart failure (diastolic heart failure), the kidneys become congested vis-à-vis renal vein hypertension. Therefore, the kidney can contribute to its own worsening failure.

The functions of the kidneys can be summarized under three broad categories: filtering blood and excreting waste products generated by the body’s metabolism; regulating salt, water, electrolyte and acid-base balance; and secreting hormones to maintain vital organ blood flow. Without properly functioning kidneys, a patient will suffer water retention, reduced urine flow and an accumulation of waste toxins in the blood and body. These conditions result from reduced renal function or renal failure (kidney failure) and are believed to increase the workload of the heart. In a CHF patient, renal failure will cause the heart to further deteriorate as fluids are retained and blood toxins accumulate due to the poorly functioning kidneys. The resulting hypertension also has dramatic influence on the progression of cerebrovascular disease and stroke.

The autonomic nervous system is a network of nerves which affect almost every organ and physiologic system to a variable degree. Generally, the system is composed of sympathetic and parasympathetic nerves. For example, the sympathetic nerves to the kidney traverse the sympathetic chain along the spine and synapse within the ganglia of the chain or within the celiac ganglia, then proceeding to innervate the kidney via post-ganglionic fibers inside the “renal nerves.” Within the renal nerves, which travel along the renal hila (artery and to some extent the vein), are the post-ganglionic sympathetic nerves and the afferent nerves from the kidney. The afferent nerves from the kidney travel within the dorsal root (if they are pain fibers) and into the anterior root if they are sensory fibers, then into the spinal cord and ultimately to specialized regions of the brain. The afferent nerves, baroreceptors and chemoreceptors, deliver information from the kidneys back to the sympathetic nervous system via the brain; their ablation or inhibition is at least partially responsible for the improvement seen in blood pressure after renal nerve

ablation, or denervation, or partial disruption. It has also been suggested and partially proven experimentally that the baroreceptor response at the level of the carotid sinus is mediated by the renal artery afferent nerves such that loss of the renal artery afferent nerve response blunts the response of the carotid baroreceptors to changes in arterial blood pressure (American J. Physiology and Renal Physiology 279:F491-F501, 2000, incorporated by reference herein).

It has been established in animal models that the heart failure condition results in abnormally high sympathetic activation of the kidneys. An increase in renal sympathetic nerve activity leads to decreased removal of water and sodium from the body, as well as increased renin secretion which stimulates aldosterone secretion from the adrenal gland. Increased renin secretion can lead to an increase in angiotensin II levels which leads to vasoconstriction of blood vessels supplying the kidneys as well as systemic vasoconstriction, all of which lead to a decrease in renal blood flow and hypertension. Reduction in sympathetic renal nerve activity, e.g., via de-innervation, may reverse these processes and in fact has been shown to in the clinic. Similarly, in obese patients, the sympathetic drive is intrinsically very high and is felt to be one of the causes of hypertension in obese patients.

Recent clinical work has shown that de-innervation of the renal sympathetic chain and other nerves which enter the kidney through the hilum can lead to profound systemic effects in patients (rats, dogs, pig, sheep, humans) with hypertension, heart failure, and other organ system diseases. Such treatment can lead to long term reduction in the need for blood pressure medications and improvements in blood pressure (O'Brien Lancet 2009 373; 9681 incorporated by reference). The devices used in this trial were highly localized radiofrequency (RF) ablation to ablate the renal artery adventitia with the presumption that the nerves surrounding the renal artery are being inhibited in the heating zone as well. The procedure is performed in essentially a blind fashion in that the exact location of the nerve plexus is not known prior to, during, or after the procedure. In addition, the wall of the renal artery is invariably damaged by the RF probe and patients whose vessels have a great deal of atherosclerosis cannot be treated safely. In addition, depending on the distance of the nerves from the vessel wall, the energy may not consistently lead to ablation or interruption. Finally, the use of internal catheters may not allow for treatment inside the kidney or inside the aorta if more selective. In many cases, it is required to create a spiral along the length and inside the blood vessel to avoid circumferential damage to the vessel.

Cross-sectional imaging can be utilized to visualize the internal anatomy of patients via radiation (CT) or magnetic fields (MRI). Ultrasound can also be utilized to obtain cross-sections of specific regions but only at high frequencies; therefore, ultrasound is typically limited to imaging superficial body regions. CT and MRI are often more amenable to cross sectional imaging because the radiation penetrates well into tissues. In addition, the scale of the body regions is maintained such that the anatomy within the coordinate references remains intact relative to one another; that is, distances between structures can be measured.

With ultrasound, scaling can be more difficult because of unequal penetration as the waves propagate deeper through the tissue. CT scans and MRIs and even ultrasound devices can be utilized to create three dimensional representations and reconstructed cross-sectional images of patients; anatomy can be placed in a coordinate reference frame using a three dimensional representation. Once in the reference frame, energy devices (transducers) can be placed in position and energy emitting devices directed such that specific

regions of the body are targeted. Once knowledge of the transducer position is known relative to the position of the target in the patient body, energy can be delivered to the target.

Ultrasound is a cyclically generated sound pressure wave with a frequency greater than the upper limit of human hearing . . . 20 kilohertz (kHz). In medicine, ultrasound is widely utilized because of its ability to penetrate tissues. Reflection of the sound waves reveals a signature of the underlying tissues and as such, ultrasound can be used extensively for diagnostics and potentially therapeutics as well in the medical field. As a therapy, ultrasound has the ability to both penetrate tissues and can be focused to create ablation zones. Because of its simultaneous ability to image, ultrasound can be utilized for precise targeting of lesions inside the body. Ultrasound intensity is measured by the power per cm^2 (for example, W/cm^2 at the therapeutic target region). Generally, high intensity refers to intensities over $0.1\text{-}5 \text{ kW}/\text{cm}^2$. Low intensity ultrasound encompasses the range up to $0.01\text{-}0.10 \text{ kW}/\text{cm}^2$ from about 1 or 10 Watts per cm^2 .

Ultrasound can be utilized for its forward propagating waves and resulting reflected waves or where energy deposition in the tissue and either heating or slight disruption of the tissues is desired. For example, rather than relying on reflections for imaging, lower frequency ultrasonic beams (e.g. <1 MHz) can be focused at a depth within tissue, creating a heating zone or a defined region of cavitation in which micro-bubbles are created, cell membranes are opened to admit bioactive molecules, or damage is otherwise created in the tissue. These features of ultrasound generally utilize frequencies in the 0.25 Megahertz (MHz) to 10 MHz range depending on the depth required for effect. Focusing is, or may be, required so that the surface of the tissue is not excessively injured or heated by single beams. In other words, many single beams can be propagated through the tissue at different angles to decrease the energy deposition along any single path yet allow the beams to converge at a focal spot deep within the tissue. In addition, reflected beams from multiple angles may be utilized in order to create a three dimensional representation of the region to be treated in a coordinate space.

It is important when planning an ultrasound therapy that sharp, discontinuous interfaces be avoided. For example, bowel, lung, bone which contain air and/or bone interfaces constitute sharp boundaries with soft tissues. These interfaces make the planning and therapy more difficult. If however, the interfaces can be avoided, then treatment can be greatly simplified versus what has to done for the brain (e.g. MR-guided HIFU) where complex modeling is required to overcome the very high attenuation of the cranium. Data provided below reveals a discovery through extensive experimentation as to how to achieve this treatment simplicity.

Time of flight measurements with ultrasound can be used to range find, or find distances between objects in tissues. Such measurements can be utilized to place objects such as vessels into three dimensional coordinate reference frames so that energy can be utilized to target the tissues. SONAR is the acronym for sound navigation and ranging and is a method of acoustic localization. Sound waves are transmitted through a medium and the time for the sound to reflect back to the transmitter is indicative of the position of the object of interest. Doppler signals are generated by a moving object. The change in the forward and reflected wave results in a velocity for the object.

The concept of speckle tracking is one in which the reflections of specific tissues is defined and tracked over time (IEEE Transactions on Ultrasonics, Ferroelectrics, AND Frequency Control, Vol. 57, no. 4, April 2010, herein incorpo-

rated by reference). With defined points in space, a three dimensional coordinate reference can be created through which energy can be applied to specific and well-defined regions. To track a speckle, an ultrasound image is obtained from a tissue. Light and dark spots are defined in the image, these light and dark spots representing inhomogeneities in the tissues. The inhomogeneities are relatively constant, being essentially properties of the tissue. With relatively constant markers in the tissue, tracking can be accomplished using real time imaging of the markers. With more than one plane of ultrasound, the markers can be related in three dimensions relative to the ultrasound transducer and a therapeutic energy delivered to a defined position within the three dimensional field.

At the time one or more of these imaging modalities is utilized to determine the position of the target in three dimensions, then a therapy can be both planned and applied to a specific region within the three dimensional volume.

Lithotripsy was introduced in the early part of the 1980's. Lithotripsy utilizes shockwaves to treat stones in the kidney. The Dormier lithotripsy system was the first system produced for this purpose. The lithotripsy system sends ultrasonic waves through the patient's body to the kidney to selectively heat and vibrate the kidney stones; that is, selectively over the adjacent tissue. At the present time, lithotripsy systems do not utilize direct targeting and imaging of the kidney stone region. A tremendous advance in the technology would be to image the stone region and target the specific region in which the stone resides so as to minimize damage to surrounding structures such as the kidney. In the case of a kidney stone, the kidney is in fact the speckle, allowing for three dimensional targeting and tracking off its image with subsequent application of ultrasound waves to break up the stone. In the embodiments which follow below, many of the techniques and imaging results described can be applied to clinical lithotripsy.

Histotripsy is a term given to a technique in which tissue is essentially vaporized using cavitation rather than heating (transcutaneous non-thermal mechanical tissue fractionation). These mini explosions do not require high temperature and can occur in less than a second. The generated pressure wave is in the range of megapascals (MPa) and even up to or exceeding 100 MPa. To treat small regions of tissue very quickly, this technique can be very effective. The border of the viable and non-viable tissue is typically very sharp and the mechanism of action has been shown to be cellular disruption.

In one embodiment, ultrasound is focused on the region of the renal arteries and/or veins from outside the patient; the ultrasound is delivered from multiple angles to the target, thereby overcoming many of the deficiencies in previous methods and devices put forward to ablate renal sympathetic nerves which surround the renal arteries.

Specifically, one embodiment allows for precise visualization of the ablation zone so that the operator can be confident that the correct region is ablated and that the incorrect region is not ablated. Because some embodiments do not require a puncture in the skin, they are considerably less invasive, which is more palatable and safer from the patient standpoint. Moreover, unusual anatomies and atherosclerotic vessels can be treated using external energy triangulated on the renal arteries to affect the sympathetic and afferent nerves to and from the kidney respectively.

With reference to FIG. 1A, the human renal anatomy includes the kidneys 100 which are supplied with oxygenated blood by the renal arteries 200 and are connected to the heart via the abdominal aorta 300. Deoxygenated blood flows from the kidneys to the heart via the renal veins (not shown) and

thence the inferior vena cava (not shown). The renal anatomy includes the cortex, the medulla, and the hilum. Blood is delivered to the cortex where it filters through the glomeruli and is then delivered to the medulla where it is further filtered through a series of reabsorption and filtration steps in the loops of henle and individual nephrons; the ultrafiltrate then percolates to the ureteral collecting system and is delivered to the ureters and bladder for ultimate excretion.

The hila is the region where the major vessels (renal artery and renal vein) and nerves 150 (efferent sympathetic, afferent sensory, and parasympathetic nerves) travel to and from the kidneys. The renal nerves 150 contain post-ganglionic efferent nerves which supply sympathetic innervation to the kidneys. Afferent sensory nerves travel from the kidney to the central nervous system and are postganglionic afferent nerves with nerve bodies in the central nervous system. These nerves deliver sensory information to the central nervous system and are thought to regulate much of the sympathetic outflow from the central nervous system to all organs including the skin, heart, kidneys, brain, etc.

In one method, energy is delivered from outside a patient, through the skin, and to the renal afferent and/or renal efferent nerves. Microwave, light, vibratory (e.g. acoustic), ionizing radiation might be utilized in some or many of the embodiments.

Energy transducers 510 (FIG. 1A) deliver energy transcutaneously to the region of the sympathetic ganglia 520 or the post-ganglionic renal nerves 150 or the nerves leading to the adrenal gland 400. The energy is generated from outside the patient, from multiple directions, and through the skin to the region of the renal nerves 624 which surround the renal artery 620 or the sympathetic ganglion 622 which house the nerves. The energy can be focused or non-focused but in one preferred embodiment, the energy is focused with high intensity focused ultrasound (HIFU) or low intensity focused ultrasound.

Focusing with low intensity focused ultrasound (LIFU) may also occur intentionally as a component of the HIFU (penumbra regions) or unintentionally. The mechanism of nerve inhibition is variable depending on the "low" or "high" of focused ultrasound. Low energy might include energies levels of 25 W/cm²-200 W/cm². Higher intensity includes energy levels from 200 W/cm² to 1 MW/cm². Focusing occurs by delivering energy from at least two different angles through the skin to meet at a focal point where the highest energy intensity and density occurs. At this spot, a therapy is delivered and the therapy can be sub-threshold nerve interruption (partial ablation), ablation (complete interruption) of the nerves, controlled interruption of the nerve conduction apparatus, partial ablation, or targeted drug delivery. The region can be heated to a temperature of less than 60 degrees Celsius for non-ablative therapy or can be heated greater than 60 degrees Celsius for heat based destruction (ablation). To ablate the nerves, even temperatures in the 40 degree Celsius range can be used and if generated for a time period greater than several minutes, will result in ablation. For temperatures at about 50 degrees Celsius, the time might be under one minute. Heating aside, a vibratory effect for a much shorter period of time at temperatures below 60 degrees Celsius can result in partial or complete paralysis of destruction of the nerves. If the temperature is increased beyond 50-60 degrees Celsius, the time required for heating is decreased considerably to affect the nerve via the sole mechanism of heating. In some embodiments, an imaging modality is included as well in the system. The imaging modality can be ultrasound based,

MRI based, or CT (X-Ray) based. The imaging modality can be utilized to target the region of ablation and determined the distances to the target.

The delivered energy can be ionizing or non-ionizing energy in some embodiments. Forms of non-ionizing energy can include electromagnetic energy such as a magnetic field, light, an electric field, radiofrequency energy, and light based energy. Forms of ionizing energy include x-ray, proton beam, gamma rays, electron beams, and alpha rays. In some embodiments, the energy modalities are combined. For example, heat ablation of the nerves is performed and then ionizing radiation is delivered to the region to prevent re-growth of the nerves.

Alternatively, ionizing radiation is applied first as an ablation modality and then heat applied afterward in the case of re-growth of the tissue as re-radiation may not be possible (complement or multimodality energy utilization). Ionizing radiation may prevent or inhibit the re-growth of the nervous tissue around the vessel if there is indeed re-growth of the nervous tissue. Therefore, another method of treating the nerves is to first heat the nerves and then apply ionizing radiation to prevent re-growth.

Other techniques such as photodynamic therapy including a photosensitizer and light source to activate the photosensitizer can be utilized as a manner to combine modalities. Most of these photosensitizing agents are also sensitive to ultrasound energy yielding the same photoreactive species as if it were activated by light. A photoreactive or photosensitive agent can be introduced into the target area prior to the apparatus being introduced into the blood vessel; for example, through an intravenous injection, a subcutaneous injection, etc. However, it will be understood that if desired, the apparatus can optionally include a lumen for delivering a photoreactive agent into the target area. The resulting embodiments are likely to be particularly beneficial where uptake of the photoreactive agent into the target tissues is relatively rapid, so that the apparatus does not need to remain in the blood vessel for an extended period of time while the photoreactive agent is distributed into and absorbed by the target tissue.

Light source arrays can include light sources that provide more than one wavelength or waveband of light. Linear light source arrays are particularly useful to treat elongate portions of tissue. Light source arrays can also include reflective elements to enhance the transmission of light in a preferred direction. For example, devices can beneficially include expandable members such as inflatable balloons to occlude blood flow (which can interfere with the transmission of light from the light source to the intended target tissue) and to enable the apparatus to be centered in a blood vessel. Another preferred embodiment contemplates a transcutaneous PDT method where the photosensitizing agent delivery system comprises a liposome delivery system consisting essentially of the photosensitizing agent.

Yet another embodiment of the present invention is drawn to a method for transcutaneous ultrasonic therapy of a target lesion in a mammalian subject utilizing a sensitizer agent. In this embodiment, the biochemical compound is activated by ultrasound through the following method:

1) administering to the subject a therapeutically effective amount of an ultrasonic sensitizing agent or a ultrasonic sensitizing agent delivery system or a prodrug, where the ultrasonic sensitizing agent or ultrasonic sensitizing agent delivery system or prodrug selectively binds to the thick or thin neointimas, nerve cells, nerve sheaths, nerve nuclei, arterial plaques, vascular smooth muscle cells and/or the abnormal extracellular matrix of the site to be treated. Nerve components can also be targeted, for example, the nerve sheath,

myelin, S-100 protein. This step is followed by irradiating at least a portion of the subject with ultrasonic energy at a frequency that activates the ultrasonic sensitizing agent or if a prodrug, by a prodrug product thereof, where the ultrasonic energy is provided by an ultrasonic energy emitting source. This embodiment further provides, optionally, that the ultrasonic therapy drug is cleared from non-target tissues of the subject prior to irradiation.

A preferred embodiment of this invention contemplates a method for transcutaneous ultrasonic therapy of a target tissue, where the target tissue is close to a blood vessel.

Other preferred embodiments of this invention contemplate that the ultrasonic energy emitting source is external to the patient's intact skin layer or is inserted underneath the patient's intact skin layer, but is external to the blood vessel to be treated. An additional preferred embodiment of this invention provides that the ultrasonic sensitizing agent is conjugated to a ligand and more preferably, where the ligand is selected from the group consisting of: a target lesion specific antibody; a target lesion specific peptide and a target lesion specific polymer. Other preferred embodiments of the present invention contemplate that the ultrasonic sensitizing agent is selected from the group consisting of: indocyanine green (ICG); methylene blue; toluidine blue; aminolevulinic acid (ALA); chlorin compounds; phthalocyanines; porphyrins; purpurins; texaphyrins; and any other agent that absorbs light in a range of 500 nm-1100 nm. A preferred embodiment of this invention contemplates that the photosensitizing agent is indocyanine green (ICG).

Other embodiments of the present invention are drawn to the presently disclosed methods of transcutaneous PDT, where the light source is positioned in proximity to the target tissue of the subject and is selected from the group consisting of: an LED light source; an electroluminescent light source; an incandescent light source; a cold cathode fluorescent light source; organic polymer light source; and inorganic light source. A preferred embodiment includes the use of an LED light source.

Yet other embodiments of the presently disclosed methods are drawn to use of light of a wavelength that is from about 500 nm to about 1100 nm, preferably greater than about 650 nm and more preferably greater than about 700 nm. A preferable embodiment of the present method is drawn to the use of light that results in a single photon absorption mode by the photosensitizing agent.

Additional embodiments of the present invention include compositions of photosensitizer targeted delivery system comprising: a photosensitizing agent and a ligand that binds a receptor on the target tissue with specificity. Preferably, the photosensitizing agent of the targeted delivery system is conjugated to the ligand that binds a receptor on the target (nerve or adventitial wall of blood vessel) with specificity. More preferably, the ligand comprises an antibody that binds to a receptor. Most preferably, the receptor is an antigen on thick or thin neointimas, intimas, adventitia of arteries, arterial plaques, vascular smooth muscle cells and/or the extracellular matrix of the site to be treated.

A further preferred embodiment of this invention contemplates that the photosensitizing agent is selected from the group consisting of: indocyanine green (ICG); methylene blue; toluidine blue; aminolevulinic acid (ALA); chlorin compounds; phthalocyanines; porphyrins; purpurins; texaphyrins; and any other agent that absorbs light in a range of 500 nm-1100 nm.

Other photosensitizers of the present invention are known in the art, including, photofrin. RTM, synthetic diporphyrins and dichlorins, phthalocyanines with or without metal sub-

stituents, chloroaluminum phthalocyanine with or without varying substituents, chloroaluminum sulfonated phthalocyanine, O-substituted tetraphenyl porphyrins, 3,1-meso tetrakis (o-propionamido phenyl) porphyrin, verdins, purpurins, tin and zinc derivatives of octaethylpurpurin, etiopurpurin, 5 hydroporphyrins, bacteriochlorins of the tetra(hydroxyphenyl) porphyrin series, chlorins, chlorin e6, mono-1-aspartyl derivative of chlorin e6, di-1-aspartyl derivative of chlorin e6, tin(IV) chlorin e6, meta-tetrahydroxyphenylchlorin, benzoporphyrin derivatives, benzoporphyrin monoacid derivatives, tetracyanoethylene adducts of benzoporphyrin, dimethyl acetylenedicarboxylate adducts of benzoporphyrin, Diels-Adler adducts, monoacid ring "a" derivative of benzoporphyrin, sulfonated aluminum PC, sulfonated AlPc, disulfonated, tetrasulfonated derivative, sulfonated aluminum 15 naphthalocyanines, naphthalocyanines with or without metal substituents and with or without varying substituents, zinc naphthalocyanine, anthracenediones, anthrapyrazoles, aminoanthraquinone, phenoxazine dyes, phenothiazine derivatives, chalcogenapyrylium dyes, cationic seleno and tellurapyrylium derivatives, ring-substituted cationic PC, pheophorbide derivative, pheophorbide alpha and ether or ester derivatives, pyropheophorbides and ether or ester derivatives, naturally occurring porphyrins, hematoporphyrin, hematoporphyrin derivatives, hematoporphyrin esters or 25 ethers, protoporphyrin, ALA-induced protoporphyrin IX, endogenous metabolic precursors, 5-aminolevulinic acid benzonaphthoporphyrazines, cationic imminium salts, tetracyclines, lutetium texaphyrin, tin-etio-purpurin, porphycenes, benzophenothiazinium, pentaphyrins, texaphyrins and hexaphyrins, 5-amino levulinic acid, hypericin, pseudo-hypericin, hypocrellin, terthiophenes, azaporphyrins, azachlorins, rose bengal, phloxine B, erythrosine, iodinated or brominated derivatives of fluorescein, merocyanines, Nile blue derivatives, pheophytin and chlorophyll derivatives, bacteriochlorin and bacteriochlorophyll derivatives, porphocyanines, benzochlorins and oxobenzochlorins, sapphyrins, oxasapphyrins, cercosporins and related fungal metabolites and combinations thereof.

Several photosensitizers known in the art are FDA 40 approved and commercially available. In a preferred embodiment, the photosensitizer is a benzoporphyrin derivative ("BPD"), such as BPD-MA, also commercially known as BPD Verteporfin or "BPD" (available from QLT). U.S. Pat. No. 4,883,790 describes BPD compositions. BPD is a second-generation compound, which lacks the prolonged cutaneous phototoxicity of Photofrin® (Levy (1994) Semin Oncol 21: 4-10). BPD has been thoroughly characterized (Richter et al., (1987) JNCI 79:1327-1331), (Aveline et al. (1994) Photochem Photobiol 59:328-35), and it has been 50 found to be a highly potent photosensitizer for PDT.

In a preferred embodiment, the photosensitizer is tin ethyl etiopurpurin, commercially known as purlytin (available from Miravant).

In some embodiments, external neuromodulation is performed in which low energy ultrasound is applied to the nerve region to modulate the nerves. For example, it has been shown in the past that low intensity (e.g. non-thermal) ultrasound can affect nerves at powers which range from 30-500 mW/cm² whereas HIFU (thermal modulation), by definition generates heat at a focus, requires power levels exceeding 1000 W/cm². The actual power flux to the region to be ablated is dependent on the environment including surrounding blood flow and other structures. With low intensity ultrasound, the energy does not have to be so strictly focused to the target because it's 65 a non-ablative energy; that is, the vibration or mechanical pressure may be the effector energy and the target may have

a different threshold for effect depending on the tissue. However, even low energy ultrasound may require focusing if excessive heat to the skin is a worry or if there are other susceptible structures in the path and only a pinpoint region of therapy is desired. Nonetheless, transducers 500 in FIG. 1a provide the ability to apply a range of different energy and power levels as well as modeling capability to target different regions and predict the response.

In FIG. 1a, and in one embodiment, a renal artery 640 is detected with the assistance of imaging devices 600 such as Doppler ultrasound, infrared imaging, thermal imaging, B-mode ultrasound, MRI, or a CT scan. With an image of the region to be treated, measurements in multiple directions on a series of slices can be performed so as to create a three-dimensional representation of the area of interest. By detecting the position of the renal arteries from more than one angle via Doppler triangulation (for example) or another triangulation technique, a three dimensional positional map can be created and the renal artery can be mapped into a coordinate reference frame. In this respect, given that the renal nerves surround the renal blood vessels in the hilum, locating the direction and lengths of the blood vessels in three dimensional coordinate reference is the predominant component of the procedure to target these sympathetic nerves. Within the three dimensional reference frame, a pattern of energy can be applied to the vicinity of the renal artery from a device well outside the vicinity (and outside of the patient altogether) based on knowledge of the coordinate reference frame.

For example, once the renal artery is placed in the coordinate reference frame with the origin of the energy delivery device, an algorithm is utilized to localize the delivery of focused ultrasound to heat or apply mechanical energy to the adventitia and surrounding regions of the artery which contain sympathetic nerves to the kidney and afferent nerves from the kidney, thereby decreasing the sympathetic stimulus to the kidney and decreasing its afferent signaling back to the autonomic nervous system; affecting these targets will modulate the propensity toward hypertension which would otherwise occur. The ultrasonic energy delivery can be modeled mathematically by predicting the acoustic wave dissipation using the distances and measurements taken with the imaging modalities of the tissues and path lengths.

In one embodiment of an algorithm, the Doppler signal from the artery is identified from at least two different directions and the direction of the artery is reconstructed in three dimensional space. With two points in space, a line is created and with knowledge of the thickness of the vessel, a tube, or cylinder, can be created to represent the blood vessel as a virtual model. The tube is represented in three dimensional space over time and its coordinates are known relative to the therapeutic transducers outside of the skin of the patient. Therapeutic energy can be applied from more than one direction as well and can focus on the cylinder (blood anterior vessel wall, central axis, or posterior wall).

55 Focused energy (e.g. ultrasound) can be applied to the center of the vessel (within the flow), on the posterior wall of the vessel, in between (e.g. when there is a back to back artery and vein next to one another) the artery vessel and a venous vessel, etc.

60 Imaging 600 of the sympathetic nerves or the sympathetic region (the target) is also utilized so as to assess the direction and orientation of the transducers relative to the target 620; the target is an internal fiducial, which in one embodiment is the kidney 610 and associated renal artery 620 because they can be localized via their blood flow, a model then produced around it, and then they both can be used as a target for the energy. Continuous feedback of the position of the transduc-

ers **500**, **510** relative to the target **620** is provided by the imaging system in which the coordinate space of the imaging system. The imaging may be a cross-sectional imaging technology such as CT or MRI or it may be an ultrasound imaging technology which yields faster real time imaging. In some embodiments, the imaging may be a combination of technologies such as the fusion of MRI/CT and ultrasound. The imaging system can detect the position of the target in real time at frequencies ranging from 1 Hz to thousands and tens of thousands of images per second.

In the example of fusion, cross-sectional imaging (e.g. MRI/CT) is utilized to place the body of the patient in a three dimensional coordinate frame and then ultrasound is linked to the three dimensional reference frame and utilized to track the patient's body in real time under the ultrasound linked to the cross-sectional imaging. The lack of resolution provided by the ultrasound is made up for by the cross-sectional imaging since only a few consistent anatomic landmarks are required for an ultrasound image to be linked to the MRI image. As the body moves under the ultrasound, the progressively new ultrasound images are linked to the MRI images and therefore MRI "movement" can be seen at a frequency not otherwise available to an MRI series.

In one embodiment, ultrasound is the energy used to inhibit nerve conduction in the sympathetic nerves. In one embodiment, focused ultrasound (HIFU) from outside the body through the skin is the energy used to inhibit sympathetic stimulation of the kidney by delivering waves from a position external to the body of a patient and focusing the waves on the sympathetic nerves on the inside of the patient and which surround the renal artery of the patient.

As is depicted in FIG. *3a-b*, transducers **900** can emit ultrasound energy from a position outside the patient to the region of the renal sympathetic nerves at the renal pedicle **200**. As shown in FIG. *1a*, an image of the renal artery **620** using an ultrasound, MRI, or CT scan can be utilized to determine the position of the kidney **610** and the renal artery **620** target. Doppler ultrasound can be used to determine the location and direction of a Doppler signal from an artery and place the vessel into a three dimensional reference frame **950**, thereby enabling the arteries **200** and hence the sympathetic nerves **220** (FIG. *3a*) around the artery to be much more visible so as to process the images and then utilize focused external energy to pinpoint the location and therapy of the sympathetic nerves. In this embodiment, ultrasound is likely the most appropriate imaging modality.

FIG. *1a* also depicts the delivery of focused energy to the sympathetic nerve trunks and ganglia **622** which run along the vertebral column and aorta **300**; the renal artery efferent nerves travel in these trunks and synapse to ganglia within the trunks. In another embodiment, ablation of the dorsal and ventral roots at the level of the ganglia or dorsal root nerves at T9-T11 (through which the afferent renal nerves travel) would produce the same or similar effect to ablation at the level of the renal arteries.

In another embodiment, FIG. *1b* illustrates the application of ionizing energy to the region of the sympathetic nerves on the renal arteries **620** and/or renal veins. In general, energy levels of greater than 20 Gy (Gray) are required for linear accelerators or low energy x-ray machines to ablate nervous tissue using ionizing energy; however, lower energy is required to stun, inhibit nervous tissue, or prevent re-growth of nervous tissue; in some embodiment, ionizing energy levels as low as 2-5 Gy or 5-10 Gy or 10-15 Gy are delivered in a single or fractionated doses.

Combinations of ionizing energy and other forms of energy can be utilized in this embodiment as well so as to prevent

re-growth of the nervous tissue. For example, a combination of heat and/or vibration and/or cavitation and/or ionizing radiation might be utilized to prevent re-growth of nervous tissue after the partial or full ablation of the nervous tissue surrounding the renal artery.

FIG. *2* illustrates the renal anatomy and surrounding anatomy with greater detail in that organs such as the stomach **700** are shown in its anatomic position overlying the abdominal aorta **705** and renal arteries **715**. In this embodiment, energy is delivered through the stomach to reach an area behind the stomach. In this embodiment, the stomach is utilized as a conduit to access the celiac ganglion **710**, a region which would otherwise be difficult to reach. The aorta **705** is shown underneath the stomach and the celiac ganglion **710** is depicted surrounding the superior mesenteric artery and aorta. A transorally placed tube **720** is placed through the esophagus and into the stomach. The tube overlies the celiac ganglion when placed in the stomach and can therefore be used to deliver sympatholytic devices or pharmaceuticals which inhibit or stimulate the autonomic celiac ganglia behind the stomach; these therapies would be delivered via transabdominal ultrasound or fluoroscopic guidance (for imaging) through the stomach. Similar therapies can be delivered to the inferior mesenteric ganglion, renal nerves, or sympathetic nerves traveling along the aorta through the stomach or other portion of the gastrointestinal tract. The energy delivery transducers **730**, **731** are depicted external to the patient and can be utilized to augment the therapy being delivered through the stomach to the celiac ganglion. Alternatively, the energy delivery transducers can be utilized for imaging the region of therapy.

In one embodiment, energy is applied to the region of the celiac ganglion from a region outside the patient. In this embodiment, fluid is placed into the gastrointestinal system, such as for example, in the stomach or small intestine. Ultrasound can then be transmitted through the gastrointestinal organs to the ganglia of interest behind the stomach.

Temporary neurostimulators can also be placed through the tube, such as, for example, in an ICU setting where temporary blockage of the autonomic ganglia may be required. Temporary neurostimulators can be used to over pace the celiac ganglion nerve fibers and inhibit their function as a nerve synapse. Inhibition of the celiac ganglion may achieve a similar function as ablation or modulation of the sympathetic nerves around the renal arteries. That is, the decrease in the sympathetic activity to the kidneys (now obtained with a more proximal inhibition) leads to the lowering of blood pressure in the patient by decreasing the degree of sympathetic outflow from the sympathetic nerve terminals. In the celiac ganglia, the blood pressure lowering effect is more profound given that the celiac ganglia are pre-ganglionic and have more nerve fibers to a greater number of regions than each renal nerve. The effect is also likely more permanent than the effect on the post-ganglionic nerve fibers.

FIG. *3a* illustrates the renal anatomy more specifically in that the renal nerves **220** extending longitudinally along the renal artery **200**, are located generally within, or just outside the adventitia, of the outer portion of the artery. Arteries are typically composed of three layers: the first is the intimal, the second is the media, and the third is the adventitia. The outer layer, the adventitia, is a fibrous tissue which contains blood vessels and nerves. The renal nerves are generally postganglionic sympathetic nerves although there are some ganglia which exist distal to the takeoff from the aorta such that some of the nerve fibers along the renal artery are in fact pre-ganglionic. By the time the fibers reach the kidney, the majority of the fibers are post-ganglionic. The afferent nerves on the

other hand leave the kidney and are post-ganglionic up to the level of the brain. These fibers do no re-grow as quickly as the efferent fibers, if at all.

Energy generators **900** deliver energy to the renal nerves accompanying the renal artery, depositing energy from multiple directions to target inhibition of the renal nerve complex. The energy generators can deliver ultrasound energy, ionizing radiation, light (photon) therapy, or microwave energy to the region. The energy can be non-focused in the case where a pharmaceutical agent is targeted to the region to be ablated or modulated. Preferably, however, the energy is focused, being applied from multiple angles from outside the body of the patient to reach the region of interest (e.g. sympathetic nerves surrounding blood vessels). The energy transducers **900** are placed in an X-Y-Z coordinate reference frame **950**, as are the organs such as the kidneys. The x-y-z coordinate frame is a real space coordinate frame. For example, real space means that the coordinate reference is identifiable in the physical world; like a GPS (global positioning system), with the physical coordinates, a physical object can be located. Once in the x-y-z coordinate reference frame, cross-sectional imaging using MRI, CT scan, and/or ultrasound is utilized to couple the internal anatomy to the energy transducers. These same transducers may be utilized for the determination of the reference point as well as the therapy. The transducers **900** in this embodiment are focused on the region of the renal nerves at the level of the renal blood vessels, the arteries and veins **200**. The focus of the beams can be inside the artery, inside the vein, on the adventitia of the artery or adventitia of the vein.

When applying ultrasonic energy across the skin to the renal artery region, energy densities of potentially over 1 MW/cm² might be required at region of interest in the adventitia of the blood vessel. Typically, however, power densities of 100 W/cm² to 3 kW/cm² would be expected to create the heating required to inhibit these nerves (see Foley et. al. Image-Guided HIFU Neurolysis of Peripheral Nerves To Treat Spasticity And Pain; Ultrasound in Med & Biol. Vol 30 (9) p 1199-1207 herein incorporated by reference). The energy may be pulsed across the skin in an unfocused manner; however, for application of heat, the transducers must be focused otherwise the skin and underlying tissues will receive too much heat. Under imaging with MRI, temperature can be measured with the MRI image. When low energy ultrasound is applied to the region, energy (power) densities in the range of 50 mW/cm² to 500 mW/cm² may be applied. Low energy ultrasound may be enough to stun or partially inhibit the renal nerves particularly when pulsed and depending on the desired clinical result. High intensity ultrasound applied to the region with only a few degrees of temperature rise may have the same effect and this energy range may be in the 0.1 kW/cm² to the 500 kW/cm² range. A train of pulses also might be utilized to augment the effect on nervous tissue. For example, a train of 100 short pulses, each less than a second and applying energy densities of 1 W/cm² to 500 W/cm². In some of the embodiments, cooling may be applied to the skin if the temperature rise is deemed too large to be acceptable. Alternatively, the ultrasound transducers can be pulsed or can be alternated with another set of transducers to effectively spread the heat across the surface of the skin. In some embodiments, the energy is delivered in a pulsed fashion to further decrease the risk to the intervening tissues between the target and the transducer. The pulses can be as close as millisecond, as described, or as long as hours, days or years.

In one method of altering the physiologic process of renal sympathetic excitation, the region around the renal arteries is imaged using CT scan, MRI, thermography, infrared imaging, optical coherence tomography (OCT), photoacoustic

imaging, pet imaging, SPECT imaging, or ultrasound, and the images are placed into a three dimensional coordinate reference frame **950**. The coordinate reference frame **950** refers to the knowledge of the relationship between anatomic structures, both two dimensional and three dimensional, the structures placed into a physical coordinate reference. Imaging devices determine the coordinate frame. Once the coordinate frame is established, the imaging and therapy transducers **900** can be coupled such that the information from the imaging system is utilized by the therapeutic transducers to position the energy. Blood vessels may provide a useful reference frame for deposition of energy as they have a unique imaging signature. An ultrasound pulse echo can provide a Doppler shift signature to identify the blood vessel from the surrounding tissue. In an MRI, CT scan, and even an ultrasound exam, intravenous contrast agents can be utilized to identify flow patterns useful to determine a coordinate reference for energy deposition. Energy transducers **900** which can deliver ultrasound, light, radiation, ionizing radiation, or microwave energy are placed in the same three-dimensional reference frame as the renal arteries, at which time a processor (e.g. using an algorithm) can determine how to direct the transducers to deliver energy to the region **220** of the nerves **910**. The algorithm consists of a targeting feature (planning feature) which allows for prediction of the position and energy deposition of the energy leaving the transducers **900**.

Once the three dimensional coordinate reference frames **950** are linked or coupled, the planning and prediction algorithm can be used to precisely position the energy beams at a target in the body.

The original imaging modality can be utilized to locate the renal sympathetic region can be used to track the motion of the region during treatment. For example, the imaging technology used at time zero is taken as the baseline scan and subsequent scans at time t1 are compared to the baseline scan, t0. The frequency of updates can range from a single scan every few seconds to many scans per second. With ultrasound as the imaging technology, the location might be updated at a frame rate greater than 50 Hz and up to several hundred Hz or thousand Hz. With MRI as the imaging modality, the imaging refresh rate might be closer to 30 Hz. In other embodiments, internally placed fiducials transmit positional information at a high frequency and this information is utilized to fuse the target with an initial external imaging apparatus. Internal fiducials might include one or more imageable elements including doppler signals, regions of blood vessels, ribs, kidneys, and blood vessels and organs other than the target (e.g. vena cava, adrenal gland, ureter). These fiducials can be used to track the region being treated and/or to triangulate to the region to be treated.

In some embodiments (FIG. 3C), a temporary fiducial **960** is placed in the region, such as in the artery **965**, renal vein **975**, aorta **945**, and/or vena cava **985**; such a fiducial is easily imageable from outside the patient.

FIG. 3D depicts an imageable transducer **960** in a blood vessel **967** within a coordinate reference **975** on a monitor system **950**. Alternatively, the temporary fiducial **960** is a transducer which further improves the ability to image and track the region to deliver therapy. The temporary fiducial might be a mechanical, optical, electromechanical, a radio-frequency radiotransmitter, global positioning tracking (GPS) device, or ultrasound responsive technology. Similar devices might be found in U.S. Pat. Nos. 6,656,131 and 7,470,241 which are incorporated by reference herein.

Internal reflections (e.g. speckles) can be tracked as well. These speckles are inherent characteristics of tissue as

imaged with ultrasound. They can be tracked and incorporated into treatment planning algorithm and then linked to the therapeutic transducers.

In some embodiments, a test dose of energy can be applied to the renal sympathetic region and then a test performed to determine if an effect was created. For example, a small amount of heat or vibratory energy can be delivered to the region of the sympathetic nerves and then a test of sympathetic activity such as microneurography (detection of sympathetic nerve activity around muscles and nerves which correlate with the beating heart) can be performed. Past research and current clinical data have shown that the sympathetic nerves to the peripheral muscles are affected by interruption of the renal afferent nerves. The degree of temperature rise with the small degree of heat can be determined through the use of MRI thermometry or an ultrasound technique and the temperature rise can be determined or limited to an amount which is reversible.

In another embodiment, a stimulus is applied to a region such as the skin and an output downstream from the skin is detected. For example, a vibratory energy might be applied to the skin and a sympathetic outflow such as the heart rate might be detected. In another embodiment, heat or cold might be applied to the skin and heart rate, blood pressure; vasoconstriction might be detected as an output.

Alternatively, ultrasonic imaging can be utilized to determine the approximate temperature rise of the tissue region. The speed of ultrasonic waves is dependent on temperature and therefore the relative speed of the ultrasound transmission from a region being heated will depend on the temperature, therefore providing measureable variables to monitor. In some embodiments, microbubbles are utilized to determine the rise in temperature. Microbubbles expand and then degrade when exposed to increasing temperature so that they can then predict the temperature of the region being heated. A technique called ultrasound elastography can also be utilized. In this embodiment, the elastic properties of tissue are dependent on temperature and therefore the elastography may be utilized to track features of temperature change. The microbubbles can also be utilized to augment the therapeutic effect of the region being targeted. For example, the microbubbles can be utilized to release a pharmaceutical when the ultrasound reaches them. Alternatively, the microbubble structure can be utilized to enhance imaging of the treatment region to improve targeting or tracking of the treatment region.

In some embodiments, only the temperature determination is utilized. That is, the temperature sensing embodiments and algorithms are utilized with any procedure in which heating is being performed. For example, in a case where heating of the renal nerve region is performed using radiofrequency ablation through the renal artery, imaging of the region from a position external to the patient can be performed while the renal artery region is being heated via radiofrequency methods. Imaging can be accomplished utilizing MRI, ultrasound, infrared, or OCT methods.

In another embodiment, a test may be performed on the baroreceptor complex at the region of the carotid artery bifurcation. After the test dose of energy is applied to the renal artery complex, pressure can be applied to the carotid artery complex; typically, with an intact baroreceptor complex, the systemic blood pressure would decrease after application of pressure to the carotid artery.

However, with renal afferent nerves which have been inhibited, the baroreceptors will not be sensitive to changes in blood pressure and therefore the efficacy of the application of the energy to the renal nerves can be determined. Other tests

include attaining indices of autonomic function such as microneurography, autonomic function variability, etc.

In another embodiment, stimulation of the baroreceptor complex is accomplished non-invasively via ultrasound pulses applied externally to the region of the carotid body. The ultrasound pulses are sufficient to stimulate the sinus to affect a blood pressure change, a change which will be affected when an afferent nerve such as the renal afferents have been altered.

More specifically, this methodology is depicted in FIG. 3E. An ultrasound pulse **980** is utilized to stimulate the carotid sinus which will lower blood pressure transiently **982** by activating the baroreceptor complex; activation of the carotid sinus **980** simulates the effect of an increase in blood pressure which leads to a compensatory outflow of parasympathetic activity and decreased sympathetic outflow, subsequently lowering blood pressure. In the instance when the afferent system (e.g. from the kidney) has been inhibited, the pressure will not be modifiable as quickly if at all. In this case, stimulating the baroreceptor complex does not result in a lowering of blood pressure **986**, then the treatment was successful. This diagnostic technique can therefore be utilized to determine the effect of a therapy on a system such as the renal nerve complex. If therapy is successful, then the modifying effect of the ultrasound pulse on the carotid sinus and blood pressure is less dramatic and the therapeutic (treatment of afferent nerves) successful; therefore, therapy can be discontinued **988** temporarily or permanently. If the blood pressure continues to decrease **982** with the baroreceptor stimulation, then the therapeutic effect has not been reached with the therapeutic treatment and it needs to be continued **984** and/or the dose increased. Other methods to stimulate the baroreceptor complex are to apply pressure in the vicinity with hands, compression balloons, and the like.

Other regions of the autonomic nervous system can also be affected directly by the technology described herein by applying energy from one region and transmitted through tissue to another region. For example, FIG. 4a illustrates a system in which energy external to the internal carotid artery **1020** is applied to a portion of the autonomic nervous system, the carotid body complex **1000**, through the internal jugular vein **1005**, and to the carotid body **1000** and/or vagus nerve **1020** region. Ablative energy, vibratory, or electrical stimulation energy can be utilized to affect the transmission of signals to and from these nerves. The transmission in this complex can be augmented, interrupted, inhibited with over-stimulation, or a combination of these effects via energy (e.g. ultrasound, electrical stimulation, etc.).

In addition, or in place of, in other embodiments, energy may be applied to peripheral nerves typically known as motor nerves but which contain autonomic fibers. Such nerves include the saphenous nerve, femoral nerves, lumbar nerves, median nerves, ulnar nerves, and radial nerves. In some embodiments, energy is applied to the nerves and specific autonomic fibers are affected rather than the other neural fibers (e.g. motor or somatic sensory fibers or efferent or afferent autonomic nerves). In some embodiments, other types of autonomic fibers are affected with energy applied internally or externally. For example, nerves surrounding the superior mesenteric artery, the inferior mesenteric artery, the femoral artery, the pelvic arteries, etc. can be affected by the energy in a specific manner so as to create changes in the autonomic responses of the blood vessels themselves or organs related to the blood vessels, the nerves running through and along the vessels to the organs.

In another embodiment, in FIG. 4a, a catheter **1010** is advanced into the internal jugular vein **1005** and when in

position, stimulation or ablative energy **1020** is directed toward the autonomic nerves, e.g. the vagus nerve and the carotid sinus/body **1000**, from the catheter positioned in the venous system **1005**.

In a similar type of embodiment **1100**, a catheter based therapeutic energy source **1110** can be inserted into the region of the renal arteries or renal veins (FIG. 4B) to stimulate or inhibit the renal nerves from the inside of the vessel, either the renal artery **1105** or renal vein **1106**. Energy is transferred through the vessel (e.g. renal vein) to reach the nerves around another vessel (e.g. renal artery). For example, a catheter delivering unfocused ultrasound energy with powers in the range of 50 mW/cm² to 50 kW/cm² can be placed into the renal artery and the energy transmitted radially around the artery or vein to the surrounding nerves. As discussed below, the 500 mW-2500 W/cm² is appropriate to create the specific nerve dysfunction to affect the norepinephrine levels in the kidney, a surrogate of nerve function which has been shown to lead to decreases in blood pressure over time. Pulsed ultrasound, for example, 100 pulse trains with each lasting less than 1 second each, can be applied to the region.

In another embodiment, light is applied through the vessel from within the blood vessel. Infrared, red, blue, and near infrared can all be utilized to affect the function of nerves surrounding blood vessels. For example, a light source is introduced into the renal artery or renal vein **1105**, **1106** and the light transmitted to the region surrounding the blood vessels. In a preferred embodiment, a photosensitizing agent is utilized to hasten the inhibition or destruction of the nerve bundles with this technique. Photosensitizing agents can be applied systemically to infiltrate the region around the blood vessels. Light is then applied from inside the vessel to the region of the nerves outside the vessel. For example, the light source is placed inside the renal vein and then light is transmitted through the vein wall to the adventitial region around the wall activating the photosensitizer and injuring or inhibiting the nerves in the adventitia through an apoptosis pathway. The light source may provide light that is visible, or light that is non-visible.

The therapies in FIGS. 4a-b can be delivered on an acute basis such as for example in an ICU or critical care setting. In such a case, the therapy would be acute and intermittent, with the source outside the patient and the catheter within the patient as shown in FIGS. 4a-b. The therapy can be utilized during times of stress for the patient such that the sympathetic system is slowed down. After the intensive care admission is nearing a close, the catheter and unit can be removed from the patient. In one embodiment, a method is described in which a catheter is placed within a patient to deliver energy to a region of the body sufficient to partially or fully inhibit an autonomic nerve complex during a state of profound sympathetic activation such as shock, sepsis, myocardial infarction, pancreatitis, post-surgical. After the acute phase of implantation during which the sympathetic system is modulated, the device is removed entirely.

FIGS. 5a-b illustrates the eye in close up detail with sympathetic nerves surrounding the posterior of the eye. In the eye, glaucoma is a problem of world-wide importance. The most commonly prescribed medication to treat glaucoma is timoptic, which is a non-selective $\beta 1$ and $\beta 2$ (adrenergic) antagonist. Compliance with this pharmaceutical is a major problem and limits its effectiveness in preventing the complications of glaucoma, the major complication being progression of visual dysfunction.

Ultrasound, or other energy transducers **7000**, can be applied to focus energy from an external region (e.g. a distance from the eye in an external location) anterior to the eye

or to a region posteriorly behind the eye **2500** on the sympathetic **2010** or parasympathetic ganglia, all of which will affect lowering of intra-ocular pressure. The energy transducers **7000** apply ablative or near ablative energy to the adventitia of the blood vessels. In some embodiments, the energy is not ablative but vibratory at frequencies (e.g. 1-5 Mhz) and penetration depths (e.g. 0.5 mm to 0.5 cm) sufficient to inhibit the function of the nerves which are responsible for intra-ocular pressure. Lower energy (e.g. sub-ablative) can be applied to the eye to assist in drug delivery or to stimulate tissue healing type of tissue responses.

FIG. 5b depicts the anatomy of the nerves which travel behind the eye **2500**. In this illustration, a catheter **2000** is tunneled through the vasculature to the region of the sympathetic nerves surrounding the arteries of the eye **2010** and utilized to ablate, stun, or otherwise modulate the efferent and/or afferent nerves through the wall of the vasculature.

FIG. 6 illustrates an overall schematic of the renal artery, renal vein, the collecting system, and the more distal vessels and collecting system within the renal parenchyma. The individual nerves of the autonomic nervous system typically follow the body vasculature and they are shown in close proximity **3000** to the renal artery as the artery enters the kidney **3100** proper. The hilum of the kidney contains pressure sensors and chemical sensors which influence the inputs to the efferent sympathetic system via afferent nerves traveling from the kidney to the central nervous system and then to the efferent nervous system. Any one or multiple of these structures can influence the function of the kidney. Ablative or non-ablative energy can be applied to the renal vein, the renal artery, the aorta, and/or the vena cava, the renal hilum, the renal parenchyma, the renal medulla, the renal cortex, etc.

In another embodiment, selective lesions, constrictions or implants **3200** are placed in the calyces of the kidney to control or impede blood flow to specific regions of the kidney. Such lesions or implants can be placed on the arterial **3010** or venous sides **3220** of the kidney. In some embodiments, the lesions/implants are created so as to selectively block certain portions of the sympathetic nerves within the kidney. The lesions also may be positioned so as to ablate regions of the kidney which produce hormones, such as renin, which can be detrimental to a patient in excess. The implants or constrictions can be placed in the aorta **3210** or the renal vein **3230**. The implants can be active implants, generating stimulating energy chronically or multiple ablative or inhibitory doses discretely over time.

In the renal vein **3230**, the implants **3220**, **3200** might cause an increase in the pressure within the kidney (by allowing blood flow to back up into the kidney and increase the pressure) which will prevent the downward spiral of systolic heart failure described above because the kidney will act as if it is experiencing a high pressure head. That is, once the pressure in the kidney is restored or artificially elevated by increased venous pressure, the relative renal hypotension signaling to retain electrolytes and water will not be present any longer and the kidney will "feel" full and the renal sympathetic stimulation will be turned off. In one embodiment, a stent which creates a stenosis is implanted using a catheter delivery system. In another embodiment, a stricture **3220** is created using heat delivered either externally or internally. Externally delivered heat is delivered via direct heating via a percutaneous procedure (through the skin to the region of the kidney) or transmitted through the skin (e.g. with HIFU focused through the skin). In one embodiment, an implant is placed between girota's fascia and the cortex of the kidney. The implant can

stimulate or inhibit nerves surrounding the renal blood vessels, or even release pharmaceuticals in a drug delivery system.

FIG. 7a depicts at least partial ablation of the renal sympathetic nerves 4400 to the kidney using an imaging system such as an MRI machine or CT scanner 4000. The MRI/CT scan can be linked to a focused ultrasound (HIFU) machine to perform the ablations of the sympathetic nerves 4400 around the region of the renal artery 4500.

The MRI/CT scan performs the imaging 4010 and transmits data (e.g. three dimensional representations of the regions of interest) to the ultrasound controller which then directs the ultrasound to target the region of interest with low intensity ultrasound (50-1000 mW/cm²), heat (>1000 mW/cm²), cavitation, or a combination of these modalities and/or including introduction of enhancing bioactive agent delivery locally or systemically (sonodynamic therapy). Optionally, a doppler ultrasound or other 3D/4D ultrasound is performed and the data pushed to the MRI system to assist with localization of the pathology; alternatively, the ultrasound data are utilized to directly control the direction of the energy being used to target the physiologic processes and CT/MRI is not obtained. Using this imaging and ablation system from a position external to a patient, many regions of the kidney can be treated such as the internal calyces 4350, the cortex 4300, the medulla 4320, the hilum 4330, and the region 4340 close to the aorta.

Further parameters which can be measured include temperature via thermal spectroscopy using MRI or ultrasound thermometry/elastography; thermal imaging is a well-known feature of MRI scanners; the data for thermal spectroscopy exists within the MRI scan and can be extrapolated from the recorded data in real time by comparing regions of interest before and after or during treatment. Temperature data overlaid on the MRI scan enables the operator of the machine to visualize the increase in temperature and therefore the location of the heating to insure that the correct region has indeed been ablated and that excessive energy is not applied to the region. Having temperature data also enables control of the ablation field as far as applying the correct temperature for ablation to the nerves. For example, the temperature over time can be determined and fed back to the operator or in an automated system, to the energy delivery device itself. Furthermore, other spectroscopic parameters can be determined using the MRI scan such as oxygenation, blood flow, or other physiologic and functional parameters. In one embodiment, an alternating magnetic field is used to stimulate and then over-stimulate or inhibit an autonomic nerve (e.g. to or from the kidney).

Elastography is a technique in which the shear waves of the ultrasound beam and reflectance are detected. The tissue characteristics change as the tissue is heated and the tissue properties change. An approximate temperature can be assigned to the tissue based on elastography and the progress of the heating can be monitored.

MRI scanners 4000 generally consist of a magnet and an RF coil. The magnet might be an electromagnet or a permanent magnet. The coil is typically a copper coil which generates a radiofrequency field. Recently, permanent magnets have been utilized to create MRI scanners which are able to be used in almost any setting, for example a private office setting. Office based MRI scanners enable imaging to be performed quickly in the convenience of a physician's office as well as requiring less magnetic force (less than 0.5 Tesla) and as a consequence, less shielding. The lower tesla magnets also provides for special advantages as far as diversity of imaging and resolution of certain features. Importantly, the permanent

magnet MRI scanners are open scanners and do not encapsulate the patient during the scan.

In one embodiment, a permanent magnet MRI is utilized to obtain an MRI image of the region of interest 4010. High intensity focused 4100 ultrasound is used to target the region of interest 4600 identified using the MRI. In one embodiment, the MRI is utilized to detect blood flow within one or more blood vessels such as the renal arteries, renal veins, superior mesenteric artery, veins, carotid arteries and veins, aortic arch coronary arteries, veins, to name a subset.

Image 4010 is or can be monitored by a health care professional to ensure that the region of interest is being treated and the treatment can be stopped if the assumed region is not being treated. Alternatively, an imaging algorithm can be initiated in which the region of interest is automatically (e.g. through image processing) identified and then subsequent images are compared to the initial demarcated region of interest.

Perhaps, most importantly, with MRI, the region around the renal arteries can be easily imaged as can any other region such as the eye, brain, prostate, breast, liver, colon, spleen, aorta, hip, knee, spine, venous tree, and pancreas. The imaging from the MRI can be utilized to precisely focus the ultrasound beam to the region of interest around the renal arteries or elsewhere in the body. With MRI, the actual nerves to be modified or modulated can be directly visualized and targeted with the energy delivered through the body from the ultrasound transducers. One disadvantage of MRI can be the frame acquisition (difficulty in tracking the target) rate as well as the cost of introducing an MRI machine into the treatment paradigm. In these regards, ultrasound imaging offers a much more practical solution.

FIG. 7d depicts a method of treating a region with high intensity focused ultrasound (HIFU). Imaging with an MRI 4520 or ultrasound 4510 (or preferably both) is performed. MRI can be used to directly or indirectly (e.g. using functional MRI or spectroscopy) to visualize the sympathetic nerves. T1 weighted or T2 weighted images can be obtained using the MRI scanner. In addition to anatomic imaging, the MRI scanner can also obtain temperature data regarding the effectiveness of the ablation zone as well as the degree to which the zone is being heated and which parts of the zones are being heated. Other spectroscopic parameters can be added as well such as blood flow and even nerve activity. Ultrasound 4510 can be used to add blood flow to the images using Doppler imaging. The spectroscopic data can be augmented by imaging moieties such as particles, imaging agents, or particles coupled to imaging agents which are injected into the patient intravenously, or locally, and proximal to the region of the renal arteries; these imaging moieties may be visualized on MRI, ultrasound, or CT scan. Ultrasound can also be utilized to determine information regarding heating. The reflectance of the ultrasonic waves changes as the temperature of the tissue changes. By comparing the initial images with the subsequent images after heating, the temperature change which occurred after the institution of heating can be determined.

In one embodiment, the kidneys are detected by a cross-sectional imaging modality such as MRI, ultrasound, or CT scan. The renal arteries and veins are detected within the MRI image utilizing contrast or not utilizing contrast. Next, the imaging data is placed into a three dimensional coordinate system which is linked to one or more ultrasound (e.g. HIFU) transducers 4540 which focus ultrasound onto the region of the renal arteries in the coordinate frame 4530. The linking, or coupling, of the imaging to the therapeutic transducers is accomplished by determining the 3 dimensional position of

the target by creating an anatomic model. The transducers are placed in a relative three dimensional coordinate frame as well. For example, the transducers can be placed in the imaging field **4520** during the MRI or CT scan such that the cross-sectional pictures include the transducers. Optionally, the transducers contain motion sensors, such as electromagnetic, optical, inertial, MEMS, and accelerometers, one or more of which allow for the transducer position to be monitored if for example the body moves relative to the transducer or the operator moves relative to the body. With the motion sensors, the position of the transducers can be determined with movement which might occur during the therapy. The updated information can then be fed back to the ultrasound therapy device so as to readjust the position of the therapy.

In one embodiment, a system is described in which the blood flow in the renal artery is detected by detecting the walls of the artery or renal vein or the blood flow in the renal artery or the renal vein. The coordinate reference of the blood vessels is then transmitted to the therapeutic transducer, for example, ultrasound. The therapeutic transducer is directed to the renal blood vessels using the information obtained by imaging. A model of the vessels indicates the blood flow of the vessels and the walls of the vessels where the nerves reside. Energy is then applied to the model of the vessels to treat the nerves around the vessels.

Alternatively, in another embodiment, ultrasound is utilized and the ultrasound image **4510** can be directly correlated to the origin of the imaging transducer. The therapeutic transducer **4540** in some embodiments is the same as the imaging transducer and therefore the therapeutic transducer is by definition coupled in a coordinate reference **4540** once the imaging transducer coordinates are known. If the therapeutic transducer and the imaging transducer are different devices, then they can be coupled by knowledge of the relative position of the two devices. The region of interest (ROI) is highlighted in a software algorithm; for example, the renal arteries, the calyces, the medullary region, the cortex, the renal hila, the celiac ganglia, the aorta, or any of the veins of the venous system as well. In another embodiment, the adrenal gland, the vessels traveling to the adrenal gland, or the autonomic nerves traveling to the adrenal gland are targeted with focused ultrasound and then either the medulla or the cortex of the adrenal gland or the nerves and arteries leading to the gland are partially or fully ablated with ultrasonic energy.

The targeting region or focus of the ultrasound is the point of maximal intensity. In some embodiments, targeting focus is placed in the center of the artery such that the walls on either side receive equivalent amounts of energy or power and can be heated more evenly than if one wall of the blood vessel is targeted. In some embodiments in which a blood vessel is targeted, the blood vessel being an artery and the artery having a closely surrounding vein (e.g. the renal artery/vein pedicle), the center of the focus might be placed at the boundary of the vein and the artery.

Once the transducers are energized **4550** after the region is targeted, the tissue is heated **4560** and a technique such as MRI thermography **4570** or ultrasound thermography is utilized to determine the tissue temperature. During the assessment of temperature, the anatomic data from the MRI scan or the Doppler ultrasound is then referenced to ensure the proper degree of positioning and the degree of energy transduction is again further assessed by the modeling algorithm **4545** to set the parameters for the energy transducers **4550**. If there is movement of the target, the transducers may have to be turned

off and the patient repositioned. Alternatively, the transducers can be redirected to a different position within the coordinate reference frame.

Ablation can also be augmented using agents such as magnetic nanoparticles or liposomal nanoparticles which are responsive to a radiofrequency field generated by a magnet. These particles can be selectively heated by the magnetic field. The particles can also be enhanced such that they will target specific organs and tissues using targeting moieties such as antibodies, peptides, etc. In addition to the delivery of heat, the particles can be activated to deliver drugs, bioactive agents, or imaging agents at the region at which action is desired (e.g. the renal artery). The particles can be introduced via an intravenous route, a subcutaneous route, a direct injection route through the blood vessel, or a percutaneous route. As an example, magnetic nanoparticles or microparticles respond to a magnetic field by generating heat in a local region around them. Similarly, liposomal particles might have a metallic particle within such that the magnetic particle heats up the region around the liposome but the liposome allows accurate targeting and biocompatibility.

The addition of Doppler ultrasound **4510** may be provided as well. The renal arteries are (if renal arteries or regions surrounding the arteries are the target) placed in a 3D coordinate reference frame **4530** using a software algorithm with or without the help of fiducial markers. Data is supplied to ultrasound transducers **4540** from a heat modeling algorithm **4545** and the transducers are energized with the appropriate phase and power to heat the region of the renal artery to between 40° C. and 90° C. within a time span of several minutes. The position within the 3D coordinate reference is also integrated into the treatment algorithm so that the ultrasound transducers can be moved into the appropriate position. The ultrasound transducers may have frequencies below 1 megahertz (MHz), from 1-20 MHz, or above 30 Mhz, or around 750 kHz, 500 kHz, or 250 kHz. The transducers may be in the form of a phased array, either linear or curved, or the transducers may be mechanically moved so as to focus ultrasound to the target of interest. In addition, MRI thermography **4570** can be utilized so as to obtain the actual temperature of the tissue being heated. These data can be further fed into the system to slow down or speed up the process of ablation **4560** via the transducers **4550**.

Aside from focused ultrasound, ultrasonic waves can be utilized directly to either heat an area or to activate pharmaceuticals in the region of interest. There are several methodologies to enhance drug delivery using focused ultrasound. For example, particles can release pharmaceutical when they are heated by the magnetic field. Liposomes can release a payload when they are activated with focused ultrasound. Ultrasound waves have a natural focusing ability if a transducer is placed in the vicinity of the target and the target contains an activateable moiety such as a bioactive drug or material (e.g. a nanoparticle sensitive to acoustic waves). Examples of sonodynamically activated moieties include some porphyrin derivatives.

So as to test the region of interest and the potential physiologic effect of ablation in that region, the region can be partially heated or vibrated with the focused ultrasound to stun or partially ablate the nerves. Next, a physiologic test such as the testing of blood pressure or measuring norepinephrine levels in the blood, kidney, blood vessels leading to or from the kidney, can be performed to ensure that the correct region was indeed targeted for ablation. Depending on the parameter, additional treatments may be performed.

Clinically, this technique might be called fractionation of therapy which underscores one of the major advantages of the

technique to apply external energy versus applying internal energy to the renal arteries. An internal technique requires invasion through the skin and entry into the renal artery lumens which is costly and potentially damaging. Patients will likely not accept multiple treatments, as they are highly

invasive and painful. An external technique allows for a less invasive treatment to be applied on multiple occasions, made feasible by the low cost and minimal invasion of the technology described herein.

In another embodiment, a fiducial is utilized to demarcate the region of interest. A fiducial can be intrinsic (e.g. part of the anatomy) or the fiducial can be extrinsic (e.g. placed in position). For example, the fiducial can be an implanted fiducial, an intrinsic fiducial, or device placed in the blood vessels, or a device placed percutaneously through a catheterization or other procedure. The fiducial can also be a bone, such as a rib, or another internal organ, for example, the liver. In one embodiment, the fiducial is a beacon or balloon or balloon with a beacon which is detectable via ultrasound. In one embodiment, the blood flow in the renal arteries, detected via Doppler or B-mode imaging, is the fiducial and its relative direction is determined via Doppler analysis. Next, the renal arteries, and specifically, the region around the renal arteries are placed into a three dimensional coordinate frame utilizing the internal fiducials. A variant of global positioning system technology can be utilized to track the fiducials within the artery or around the arteries. In this embodiment, a position sensor is placed in the artery or vein through a puncture in the groin. The position of the sensor is monitored as the sensor is placed into the blood vessel and its position in physical space relative to the outside of the patient, relative to the operator and relative to the therapeutic transducer is therefore known. The three dimensional coordinate frame is transmitted to the therapeutic ultrasound transducers and then the transducers and anatomy are coupled to the same coordinate frame. At this point, the HIFU is delivered from the transducers, calculating the position of the transducers based on the position of the target in the reference frame.

In one embodiment, a virtual fiducial is created via an imaging system. For example, in the case of a blood vessel such as the renal artery, an image of the blood vessel using B-mode ultrasound can be obtained which correlates to the blood vessel being viewed in direct cross section (1705; FIG. 17F). When the vessel is viewed in this type of view, the center of the vessel can be aligned with the center 1700 of an ultrasound array (e.g. HIFU array 1600) and the transducers can be focused and applied to the vessel, applying heat lesions 1680 to regions around the vessel 1705. With different positions of the transducers 1610 along a circumference or hemisphere 1650, varying focal points can be created 1620, 1630, 1640. The directionality of the transducers allows for a lesion (s) 1620, 1630, 1640 which run lengthwise along the vessel 1700. Thus, a longitudinal lesion 1620-1640 can be produced along the artery to insure maximal inhibition of nerve function. In some embodiments, the center of the therapeutic ultrasound transducer is off center relative to the center of the vessel so that the energy is applied across the vessel wall at an angle, oblique to the vessel.

In this method of treatment, an artery such as a renal artery is viewed in cross-section or close to a cross-section under ultrasound guidance. In this position, the blood vessel is substantially parallel to the axis of the spherical transducer so as to facilitate lesion production. The setup of the ultrasound transducers 1600 has previously been calibrated to create multiple focal lesions 1620, 1630, 1640 along the artery if the artery is in cross-section 1680.

In one embodiment, the fiducial is an intravascular fiducial such as a balloon or a hermetically sealed transmitting device. The balloon is detectable via radiotransmitter within the balloon which is detectable by the external therapeutic transducers. The balloon can have three transducers, each capable of relaying its position so that the balloon can be placed in a three dimensional coordinate reference. Once the balloon is placed into the same coordinate frame as the external transducers using the transmitting beacon, the energy transducing devices can deliver energy (e.g. focused ultrasound) to the blood vessel (e.g. the renal arteries) or the region surrounding the blood vessels (e.g. the renal nerves). The balloon and transmitters also enable the ability to definitively track the vasculature in the case of movement (e.g. the renal arteries).

In another embodiment, the balloon measures temperature or is a conduit for coolant applied during the heating of the artery or nerves.

Delivery of therapeutic ultrasound energy to the tissue inside the body is accomplished via the ultrasound transducers which are directed to deliver the energy to the target in the coordinate frame.

Once the target is placed in the coordinate frame and the energy delivery is begun, it is important to maintain targeting of the position, particularly when the target is a small region such as the sympathetic nerves. To this end, the position of the region of ablation is compared to its baseline position, both in a three dimensional coordinate reference frame. The ongoing positional monitoring and information is fed into an algorithm which determines the new targeting direction of the energy waves toward the target. In one embodiment, if the position is too far from the original position (e.g. the patient moves), then the energy delivery is stopped and the patient repositioned. If the position is not too far from the original position, then the energy transducers can be repositioned either mechanically (e.g. through physical movement) or electrically via phased array (e.g. by changing the relative phase of the waves emanating from the transducers). In another embodiment, multiple transducers are placed on the patient in different positions and each is turned on or off to result in the necessary energy delivery. With a multitude of transducers placed on the patient, a greater territory can be covered with the therapeutic ultrasound. The therapeutic positions can also serve as imaging positions for intrinsic and/or extrinsic fiducials.

In addition to heat delivery, ultrasound can be utilized to deliver cavitating energy which may enable drug delivery at certain frequencies. Cavitating energy can also lead to ablation of tissue at the area of the focus. A systemic dose of a drug can be delivered to the region of interest and the region targeted with the cavitating or other forms of ultrasonic energy. Other types of therapeutic delivery modalities include ultrasound sensitive bubbles or radiation sensitive nanoparticles, all of which enhance the effect of the energy at the target of interest.

FIG. 7E depicts the anatomy of the region 4600, the kidneys 4620, renal arteries 4630, and bony structures 4610, 4640 as viewed from behind a human patient. FIG. 7E depicts the real world placement of the renal arteries into coordinate frame as outlined in FIG. 7D. Cross sectional CT scans from actual human patients were integrated to create a three-dimensional representation of the renal artery, kidney, and mid-torso region. Plane 4623 is a plane parallel to the transverse processes and angle 4607 is the angle one has to look up in order to "see" the renal artery under the rib.

FIG. 7F depicts an image of the region of the renal arteries and kidney 4605 using ultrasound. The renal hilum containing the arteries and vein 4640 can be visualized using this

imaging modality. This image is typical when looking at the kidney and renal artery from the direction and angle depicted in FIG. 7E. Importantly, at the angle 4607 in 7E, there is no rib in the ultrasound path and there no other important structures in the path either.

An ultrasound imaging trial was then performed to detect the available windows to deliver therapeutic ultrasound to the region of the renal arteries 4630 from the posterior region of the patient. It was discovered that the window depicted by arrow 4600 and depicted by arrow 4605 in the cross-sectional ultrasound image from ultrasound (FIG. 7F) provided optimal windows to visualize the anatomy of interest (renal pedicle 4640).

FIG. 7G contains some of the important data from the trial 4700, the data in the "standard position 4730." These data 4720 can be used to determine the configuration of the clinical HIFU system to deliver ultrasound to the renal hilum. The renal artery 4635 was determined to be 7-17 cm from the skin in the patients on average. The flank to posterior approach was noted to be optimum to image the renal artery, typically through the parenchyma of the kidney as shown in FIG. 7F 4605. The hilum 4640 of the kidney is approximately 4-8 cm from the ultrasound transducer and the angle of approach 4637 (4607 in FIG. 7E) relative to an axis defined by the line connecting the two spinous processes and perpendicular to the spine . . . is approximately -10 to -48 degrees. It was also noted that the flank approach through the kidney was the safest approach in that it represents the smallest chances of applying ultrasound to other organs such as bowel.

Upon further experimentation, it was discovered that by positioning the patient in the prone position (backside up, abdomen down), the structures under study 4750 . . . that is, the renal arteries 4770 and 4780, the kidney hilum were even closer to the skin and the respiratory motion of the artery and kidney was markedly decreased. FIG. 7H depicts these results 4750, 4760 showing the renal artery 4770 at 6-10 cm and the angle of approach 4790 relative to the spine 4607 shallower at -5 to -20 degrees.

Therefore, with these clinical data, in one embodiment, a method of treatment 4800 (FIG. 7I) of the renal nerves in a patient has been devised: 1) identify the rib 4810 and iliac crest 4840 of a patient on the left and right flank of the patient 4810; 2) identify the left or right sided kidney with ultrasound 4820; 3) identify the hilum of the kidney and the extent the renal hilum is visible along surface of patient 4820 using an imaging technology; 4) identify the blood vessels leading to the kidney from one or more angles, extracting the extent of visibility 4860 along the surface area of the patient's back; 5) determine the distance to the one or more of the renal artery, renal vein, kidney, and the renal hilum 4850; 6) optionally, position patient in the prone position with a substantive positioning device underneath the back of the patient or overtop the abdomen of the patient 4830, to optimize visibility; 7) optionally determine, through modeling, the required power to obtain a therapeutic dose at the renal hilum and region around the renal blood vessels; 8) apply therapeutic energy to renal blood vessels; 9) optionally track the region of the blood vessels to ensure the continued delivery of energy to the region as planned in the modeling; 10) optionally, turning off delivery of energy in the case the focus of the energy is outside of the planned region.

FIG. 8A depicts a percutaneous procedure and device 5010 in which the region around the renal artery 5030 is directly approached through the skin from an external position. A combination of imaging and application of energy (e.g. ablation) may be performed to ablate the region around the renal artery to treat hypertension, end stage renal disease, and heart

failure. Probe 5010 is positioned through the skin and in proximity to the kidney 5030. The probe may include sensors at its tip 5020 which detect heat or temperature or may enable augmentation of the therapeutic energy delivery. Ablative, ionizing energy, heat, or light may be applied to the region to inhibit the sympathetic nerves around the renal artery using the probe 5010. Ultrasound, radiofrequency, microwave, direct heating elements, and balloons with heat or energy sources may be applied to the region of the sympathetic nerves. Imaging may be included on the probe or performed separately while the probe is being applied to the region of the renal blood vessels.

In one embodiment, the percutaneous procedure in FIG. 8A is performed under MRI, CT, or ultrasound guidance to obtain localization or information about the degree of heat being applied. In one embodiment, ultrasound is applied but at a sub-ablative dose. That is, the energy level is enough to damage or inhibit the nerves but the temperature is such that the nerves are not ablated but paralyzed or partially inhibited by the energy. A particularly preferred embodiment would be to perform the procedure under guidance from an MRI scanner because the region being heated can be determined anatomically in real time as well via temperature maps. As described above, the images after heating can be compared to those at baseline and the signals are compared at the different temperatures.

In one embodiment, selective regions of the kidney are ablated through the percutaneous access route; for example, regions which secrete hormones which are detrimental to a patient or to the kidneys or other organs. Using energy applied externally to the patient through the skin and from different angles affords the ability to target any region in or on the kidney or along the renal nerves or at the region of the adrenal gland, aorta, or sympathetic chain. This greater breadth in the number of regions to be targeted is enabled by the combination of external imaging and external delivery of the energy from a multitude of angles through the skin of the patient and to the target. The renal nerves can be targeted at their takeoff from the aorta onto the renal artery, at their synapses at the celiac ganglia, or at their bifurcation point along the renal artery.

In a further embodiment, probe 5010 can be utilized to detect temperature or motion of the region while the ultrasound transducers are applying the energy to the region. A motion sensor, position beacon, or accelerometer can be used to provide feedback for the HIFU transducers. In addition, an optional temperature or imaging modality may be placed on the probe 5010. The probe 5010 can also be used to locate the position within the laparoscopic field for the ablations to be performed. The dose delivered by this probe is approximately

In FIG. 8B, intravascular devices 5050, 5055 are depicted which apply energy to the region around the renal arteries 5065 from within the renal arteries. The intravascular devices can be utilized to apply radiofrequency, ionizing radiation, and/or ultrasound (either focused or unfocused) energy to the renal artery and surrounding regions. MRI or ultrasound or direct thermometry can be further utilized to detect the region where the heat is being applied while the intravascular catheter is in place.

In one embodiment, devices 5050, 5055 (FIG. 8B) apply ultrasound energy which inhibits nerve function not by heating, but by mechanisms such as periodic pressure changes, radiation pressure, streaming or flow in viscous media, and pressures associated with cavitation, defined as the formation of holes in liquid media. Heat can selectively be added to these energies but not to create a temperature which ablates the nerves, only facilitates the mechanism of vibration and

pressure. In this embodiment, the ultrasound is not focused but radiates outward from the source to essentially create a cylinder of ultrasonic waves that intersect with the wall of the blood vessel. An interfacial material between the ultrasound transducer and the wall of the artery may be provided such that the ultrasound is efficiently transduced through the arterial wall to the region of the nerves around the artery. In another embodiment, the ultrasound directly enters the blood and propagates through the ultrasound wall to affect the nerves. In some embodiments, cooling is provided around the ultrasound catheter which protects the inside of the vessel yet allows the ultrasound to penetrate through the wall to the regions outside the artery. A stabilization method for the ultrasound probe is also included in such a procedure. The stabilization method might include a stabilizing component added to the probe and may include a range finding element component of the ultrasound so that the operator knows where the ultrasound energy is being applied.

Imaging can be performed externally or internally in this embodiment in which a catheter is placed inside the renal arteries. For example, external imaging with MRI or Ultrasound may be utilized to visualize changes during the ultrasound modulation of the nerve bundles. Indeed, these imaging modalities may be utilized for the application of any type of energy within the wall of the artery. For example, radiofrequency delivery of energy through the wall of the renal artery may be monitored through similar techniques. Thus the monitoring of the procedural success of the technique is independent of the technique in most cases.

Alternatively, in another embodiment, the devices **5050**, **5055** can be utilized to direct externally applied energy (e.g. ultrasound) to the correct place around the artery as the HIFU transducers deliver the energy to the region. For example, the intravascular probe **5050** can be utilized as a homing beacon for the imaging/therapeutic technology utilized for the externally delivered HIFU.

FIG. **8C** depicts a percutaneous procedure to inhibit the renal sympathetic nerves. Probe **5010** is utilized to approach the renal hilum **5060** region from posterior and renal artery **5065**. With the data presented below, the probe can be armed with HIFU to denervate the region. The data presented below indicates the feasibility of this approach as far as ultrasound enabling denervation of the vessels quickly and easily.

In another embodiment, the physiologic process of arterial expansion (aneurysms) is targeted. In FIG. **9a**, an ultrasound transducer is **6005** is placed near the wall of an aneurysm **6030**. Ultrasonic energy **6015** is applied to the wall **6030** of the aneurysm to thicken the wall and prevent further expansion of the aneurysm. In some embodiments, clot within the aneurysm is targeted as well so that the clot is broken up or dissolved with the ultrasonic energy. Once the wall of the aneurysm is heated with ultrasonic energy to a temperature of between 40 and 70 degrees, the collagen, elastin, and other extracellular matrix in the wall will harden as it cools, thereby preventing the wall from further expansion.

In another embodiment, a material is placed in the aneurysm sac and the focused or non-focused ultrasound utilized to harden or otherwise induce the material in the sac to stick to the aorta or clot in the aneurysm and thus close the aneurysm permanently. In one embodiment therefore, an ultrasound catheter is placed in an aorta at the region of an aneurysm wall or close to a material in an aneurysmal wall. The material can be a man-made material placed by an operator or it can be material such as thrombus which is in the aneurysm naturally. Ultrasound is applied to the wall, or the material, resulting in hardening of the wall or of the material, strengthening the aneurysm wall and preventing expansion. The

energy can also be applied from a position external to the patient or through a percutaneously positioned energy delivering catheter.

FIG. **9b** **6000** depicts a clot prevention device **6012** (vena cava filter) within a blood vessel such as the aorta or vena cava **6010**. The ultrasound catheter **6005** is applied to the clot prevention device (filter) **6012** so as to remove the clot from the device or to free the device **6012** from the wall of the blood vessel in order to remove it from the blood vessel **6000**.

FIG. **9c** depicts a device and method in which the celiac plexus **6020** close to the aorta **6000** is ablated or partially heated using heat or vibrational energy from an ultrasonic energy source **6005** which can apply focused or unfocused sound waves **6007** at frequencies ranging from 20 kilohertz to 5 Mhz and at powers ranging from 1 mW to over 100 kW in a focused or unfocused manner. Full, or partial ablation of the celiac plexus **6020** can result in a decrease in blood pressure via a similar mechanism as applying ultrasonic energy to the renal nerves; the ablation catheter is a focused ultrasound catheter but can also be a direct (unfocused) ultrasonic, a microwave transducer, or a resistive heating element. Energy can also be delivered from an external position through the skin to the aorta or celiac plexus region.

FIG. **10** depicts a method **6100** to treat a patient with high intensity or low intensity focused ultrasound (HIFU or LIFU) **6260**. In a first step, a CT and/or MRI scan and/or thermography and/or ultrasound (1D,2D,3D) is performed **6110**. A fiducial or other marking on or in the patient **6120** is optionally used to mark and track **6140** the patient. The fiducial can be an implanted fiducial, a temporary fiducial placed internally or externally in or on the patient, or a fiducial intrinsic to the patient (e.g. bone, blood vessel, arterial wall) which can be imaged using the CT/MRI/Ultrasound devices **6110**. The fiducial can further be a temporary fiducial such as a catheter temporarily placed in an artery or vein of a patient or a percutaneously placed catheter. A planning step **6130** for the HIFU treatment is performed in which baseline readings such as position of the organ and temperature are determined; a HIFU treatment is then planned using a model (e.g. finite element model) to predict heat transfer, or pressure to heat transfer, from the ultrasound transducers **6130**. The planning step incorporates the information on the location of the tissue or target from the imaging devices **6110** and allows placement of the anatomy into a three dimensional coordinate reference such that modeling **6130** can be performed.

The planning step **6130** includes determination of the positioning of the ultrasound transducers as far as position of the focus in the patient. X, Y, Z, and up to three angular coordinates are used to determine the position of the ultrasonic focus in the patient based on the cross sectional imaging **6110**. The HIFU transducers might have their own position sensors built in so that the position relative to the target can be assessed. Alternatively, the HIFU transducers can be rigidly fixed to the table on which the patient rests so that the coordinates relative to the table and the patient are easily obtainable. The flow of heat is also modeled in the planning step **6130** so that the temperature at a specific position with the ultrasound can be planned and predicted. For example, the pressure wave from the transducer is modeled as it penetrates through the tissue to the target. For the most part, the tissue can be treated as water with a minimal loss due to interfaces. Modeling data predicts that this is the case. The relative power and phase of the ultrasonic wave at the target can be determined by the positional coupling between the probe and target. A convective heat transfer term is added to model heat transfer due to blood

flow, particularly in the region of an artery. A conductive heat transfer term is also modeled in the equation for heat flow and temperature.

Another variable which is considered in the planning step is the size of the lesion and the error in its position. In the ablation of small regions such as nerves surrounding blood vessels, the temperature of the regions may need to be increased to a temperature of 60-90 degrees Celsius to permanently ablate nerves in the region. Temperatures of 40-60 degrees may temporarily inhibit or block the nerves in these regions and these temperatures can be used to determine that a patient will respond to a specific treatment without permanently ablating the nerve region. Subsequently, additional therapy can be applied at a later time so as to complete the job or perhaps, re-inhibit the nerve regions.

An error analysis is also performed during the treatment contemplated in FIG. 10. Each element of temperature and position contains an error variable which propagates through the equation of the treatment. The errors are modeled to obtain a virtual representation of the temperature mapped to position. This map is correlated to the position of the ultrasound transducers in the treatment of the region of interest.

During the delivery of the treatment 6260, the patient may move, in which case the fiducials 6120 track the movement and the position of the treatment zone is re-analyzed 6150 and the treatment is restarted or the transducers are moved either mechanically or electrically to a new focus position.

In another embodiment, a cross-sectional technique of imaging is used in combination with a modality such as ultrasound to create a fusion type of image. The cross-sectional imaging is utilized to create a three dimensional data set of the anatomy. The ultrasound, providing two dimensional images, is linked to the three dimensional imaging provided by the cross-sectional machine through fiducial matches between the ultrasound and the MRI. As a body portion moves within the ultrasound field, the corresponding data is determined (coupled to) the cross-sectional (e.g. MRI image) and a viewing station can show the movement in the three dimensional dataset. The ultrasound provides real time images and the coupling to the MRI or other cross-sectional image depicts the ultrasound determined position in the three dimensional space.

FIG. 11 depicts the treatment 7410 of another disease in the body of a patient, this time in the head of a patient. Subdural and epidural hematomas occur as a result of bleeding of blood vessels in the dural or epidural spaces of the brain, spinal column, and scalp. FIG. 11 depicts a CT or MRI scanner 7300 and a patient 7400 therein. An image is obtained of the brain 7000 using a CT or MRI scan. The image is utilized to couple the treatment zone 7100 to the ultrasound array utilized to heat the region. In one embodiment 7100, a subdural hematoma, either acute or chronic, is treated. In another embodiment 7200, an epidural hematoma is treated. In both embodiments, the region of leaking capillaries and blood vessels are heated to stop the bleeding, or in the case of a chronic subdural hematoma, the oozing of the inflammatory capillaries.

In an exemplary embodiment of modulating physiologic processes, a patient 7400 with a subdural or epidural hematoma is chosen for treatment and a CT scan or MRI 7300 is obtained of the treatment region. Treatment planning ensues and the chronic region of the epidural 7200 or subdural 7010 hematoma is targeted for treatment with the focused ultrasound 7100 transducer technology. Next the target of interest is placed in a coordinate reference frame as are the ultrasound transducers. Therapy 7100 ensues once the two are coupled together. The focused ultrasound heats the

region of the hematoma to dissolve the clot and/or stop the leakage from the capillaries which lead to the accumulation of fluid around the brain 7420. The technology can be used in place of or in addition to a burr hole, which is a hole placed through the scalp to evacuate the fluid.

FIG. 12 depicts a laparoscopic based approach 8000 to the renal artery region in which the sympathetic nerves 8210 can be ligated, interrupted, or otherwise modulated. In laparoscopy, the abdomen of a patient is insufflated and laparoscopic instruments introduced into the insufflated abdomen. The retroperitoneum is easily accessible through a flank approach or (less so) through a transabdominal (peritoneal) approach. A laparoscopic instrument 8200 with a distal tip 8220 can apply heat or another form of energy or deliver a drug to the region of the sympathetic nerves 8210. The laparoscopic instrument can also be utilized to ablate or alter the region of the celiac plexus 8300 and surrounding ganglia. The laparoscope can have an ultrasound transducer 8220 attached, a temperature probe attached, a microwave transducer attached, or a radiofrequency transducer attached. The laparoscope can be utilized to directly ablate or stun the nerves (e.g. with a lower frequency/energy) surrounding vessels or can be used to ablate or stun nerve ganglia which travel with the blood vessels. Similar types of modeling and imaging can be utilized with the percutaneous approach as with the external approach to the renal nerves. With the discovery through animal experimentation (see below) that a wide area of nerve inhibition can be affected with a single ultrasound probe in a single direction (see above), the nerve region does not have to be directly contacted with the probe, the probe instead can be directed in the general direction of the nerve regions and the ultrasound delivered. For example, the probe can be placed on one side of the vessel and activated to deliver focused or semi-focused ultrasound over a generalized region which might not contain greater than 1 cm of longitudinal length of the artery but its effect is enough to completely inhibit nerve function along.

FIG. 13 depicts an algorithm 8400 for the treatment of a region of interest using directed energy from a distance. MRI and/or CT with or without an imaging agent 8410 can be utilized to demarcate the region of interest (for example, the ablation zone) and then ablation 8420 can be performed around the zone identified by the agent using any of the modalities above. This algorithm is applicable to any of the therapeutic modalities described above including external HIFU, laparoscopic instruments, intravascular catheters, percutaneous catheters and instruments, as well as any of the treatment regions including the renal nerves, the eye, the kidneys, the aorta, or any of the other nerves surrounding peripheral arteries or veins. Imaging 8430 with CT, MRI, ultrasound, or PET can be utilized in real time to visualize the region being ablated. At such time when destruction of the lesion is complete 8440, imaging with an imaging (for example, a molecular imaging agent or a contrast agent such as gadolinium) agent 8410 can be performed again. The extent of ablation can also be monitored by monitoring the temperature or the appearance of the ablated zone under an imaging modality. Once lesion destruction is complete 8440, the procedure is finished. In some embodiments, ultrasonic diagnostic techniques such as elastography are utilized to determine the progress toward heating or ablation of a region.

FIG. 14 depicts ablation in which specific nerve fibers of a nerve are targeted using different temperature gradients, power gradients, or temperatures 8500. For example, if temperature is determined by MRI thermometry or with another technique such as ultrasound, infrared thermography, or a thermocouple, then the temperature can be kept at a tempera-

ture in which only certain nerve fibers are targeted for destruction or inhibition. Alternatively, part or all of the nerve can be turned off temporarily to then test the downstream effect of the nerve being turned off. For example, the sympathetic nerves around the renal artery can be turned off with a small amount of heat or other energy (e.g. vibrational energy) and then the effect can be determined. For example, norepinephrine levels in the systemic blood, kidney, or renal vein can be assayed; alternatively, the stimulation effect of the nerves can be tested after temporary cessation of activity (e.g. skin reactivity, blood pressure lability, cardiac activity, pulmonary activity, renal artery constriction in response to renal nerve stimulation). For example, in one embodiment, the sympathetic activity within a peripheral nerve is monitored; sympathetic activity typically manifests as spikes within a peripheral nerve electrical recording. The number of spike correlates with the degree of sympathetic activity or overactivity. When the activity is decreased by (e.g. renal artery de-innervation), the concentration of spikes in the peripheral nerve train is decreased, indicating a successful therapy of the sympathetic or autonomic nervous system. Varying frequencies of vibration can be utilized to inhibit specific nerve fibers versus others. For example, in some embodiments, the efferent nerve fibers are inhibited and in other embodiments, the afferent nerve fibers are inhibited. In some embodiments, both types of nerve fibers are inhibited, temporarily or permanently. In some embodiments, the C fibers **8520** are selectively blocked at lower heat levels than the A nerve fibers. In other embodiment, the B fibers are selectively treated or blocked and in some embodiments, the A fibers **8530** are preferentially blocked. In some embodiments, all fibers are inhibited by suturing the nerve with a high dose of ultrasound **8510**. Based on the experimentation described above, the power density to achieve full blockage might be around 100-800 W/cm² or with some nerves from about 500 to 2500 W/cm². In some embodiments, a pulse train of 100 or more pulses each lasting 1-2 seconds (for example) and delivering powers from about 50 w/cm² to 500 W/cm². Indeed, prior literature has shown that energies at or about 100 W/Cm² is adequate to destroy or at least inhibit nerve function (Lele, P P. Effects of Focused Ultrasound Radiation on Peripheral Nerve, with Observations on Local Heating. Experimental Neurology 8, 47-83 1963 incorporated by reference).

FIG. **15a** depicts treatment **8600** of a vertebral body or intervertebral disk **8610** in which nerves within **8640** or around the vertebral column **8630** are targeted with energy **8625** waves. In one embodiment, nerves around the facet joints are targeted. In another embodiment, nerves leading to the disks or vertebral endplates are targeted. In another embodiment, nerves within the vertebral bone **8630** are targeted by heating the bone itself. Sensory nerves run through canals **8635** in the vertebral bone **8630** and can be inhibited or ablated by heating the bone **8630**.

FIG. **15B** depicts a close-up of the region of the facet joint. Focused ultrasound to this region can inhibit nerves involved in back pain which originate at the dorsal root nerve and travel to the facet joint **8645**. Ablation or inhibition of these nerves can limit or even cure back pain due to facet joint arthropathy. Focused ultrasound can be applied to the region of the facet joint from a position outside the patient to the facet joint using powers of between 100 W/cm² and 2500 W/cm² at the nerve from times ranging from 1 second to 10 minutes.

FIG. **16A** depicts a set of lesion types, sizes, and anatomies **8710a-f** which lead to de-innervation of the different portions of the sympathetic nerve tree around the renal artery. For example, the lesions can be annular, cigar shaped, linear, doughnut and/or spherical; the lesions can be placed around

the renal arteries **8705**, inside the kidney **8710**, and/or around the aorta **8700**. For example, the renal arterial tree comprises a portion of the aorta **8700**, the renal arteries **8705**, and kidneys **8715**. Lesions **8714** and **8716** are different types of lesions which are created around the aorta **8700** and vascular tree of the kidneys. Lesions **8712** and **8718** are applied to the pole branches from the renal artery leading to the kidney and inhibit nerve functioning at branches from the main renal artery. These lesions also can be applied from a position external to the patient. Lesions can be placed in a spiral shape **8707** along the length of the artery as well. These lesions can be produced using energy delivered from outside the blood vessels using a completely non-invasive approach in which the ultrasound is applied through the skin to the vessel region or the energy can be delivered via percutaneous approach. Either delivery method can be accomplished through the posterior approach to the blood vessels as discovered and described above.

In one method therefore, ultrasound energy can be applied to the blood vessel leading to a kidney in a pattern such that a circular pattern of heat and ultrasound is applied to the vessel. The energy is transmitted through the skin in one embodiment or through the artery in another embodiment. As described below, ultrasound is transmitted from a distance and is inherently easier to apply in a circular pattern because it doesn't only rely on conduction.

Previously, it was unknown and undiscovered whether or not the annular shaped lesions as shown in FIG. **16a** would have been sufficient to block nerve function of the autonomic nerves around the blood vessels. Applicant of the subject application discovered that the annular shaped ablations **8710** not only block function but indeed completely block nerve function around the renal artery and kidney and with very minimal damage (FIG. **16C**), if any, to the arteries and veins themselves. In these experiments, focused ultrasound was used to block the nerves; the ultrasound was transmitted through and around the vessel from the top (that is, only one side of the vessel) at levels of 200-2500 W/cm². Simulations are shown in FIG. **16B** and described below. Norepinephrine levels in the kidney **8780**, which are utilized to determine the degree of nerve inhibition, were determined before and after application of energy. The lower the levels of norepinephrine, the more nerves which have been inhibited. In these experiments which were performed, the norepinephrine levels approached zero **8782** versus controls **8784** which remained high. In fact, the levels were equal to or lower than the surgically denuded blood vessels (surgical denudement involves directly cutting the nerves surgically). It is important that the renal artery and vein walls were remained substantially unharmed; this is likely due to the fact that the quick arterial blood flow removes heat from the vessel wall and the fact that the main renal artery is extremely resilient due to its large size, high blood flow, and thick wall. To summarize, ultrasound (focused and relatively unfocused) was applied to one side of the renal artery and vein complex. The marker of nerve inhibition, norepinephrine levels inside the kidney, were determined to be approaching zero after application to the nerves from a single direction, transmitting the energy through the artery wall to reach nerves around the circumference of the artery. The level of zero norepinephrine **8782** indicates essentially complete abolition of nerve function proving that the annular lesions were in fact created as depicted in FIG. **16A** and simulated in FIG. **16B**. Histological results also confirm the annular nature of the lesions and limited collateral damage as predicted by the modeling in **16B**.

Therefore, in one embodiment, the ultrasound is applied from a position external to the artery in such a manner so as to create an annular or semi-annular rim of heat all the way around the artery to inhibit, ablate, or partially ablate the autonomic nerves surrounding the artery. The walls or the blood flow of the artery can be utilized to target the ultrasound to the nerves which, if not directly visualized, are visualized by use of a model to approximate the position of the nerves based on the position of the blood vessel.

FIG. 16B further supports the physics and physiology described herein, depicting a theoretical simulation of the physical and animal experimentation described above. That is, focused ultrasound was targeted to a blood vessel in a computer simulation. The renal artery is depicted within the heating zone generated within a focused ultrasound field. Depicted is the temperature at <1 s and at approximately 5 s and longer time >10 s. Flow direction is shown as well. The larger ovals depict higher temperatures with the central temperature $>100^\circ$ C. The ultrasound field is transmitted through the artery, with heat building up around the artery as shown via the temperature maps. Importantly, this theoretical simulation also reveals the ability of the ultrasound to travel through the artery and affect both walls of the blood vessel. These data are consistent with the animal experimentation described above, creating a unified physical and experimental dataset.

Therefore, based on the animal and theoretical experimentation, there is proven feasibility of utilizing ultrasound to quickly and efficiently inhibit the nerves around the renal arteries from a position external to the blood vessels as well as from a position external to the skin of the patient.

Utilizing the experimental simulations and animal experimentation described above, a clinical device can and has been devised and tested in human patients. FIG. 17A depicts a multi-transducer HIFU device which applies a finite lesion along an artery leading to a kidney. The lesion can be spherical in shape, cigar shaped, annular shaped, or point shaped; however, in a preferred embodiment, the lesion runs along the length of the artery and has a cigar shaped. This lesion is generated by a spherical or semi-spherical type of ultrasound array in a preferred embodiment. Multiple cigar shaped lesion as shown in FIG. 17C leads to a ring type of lesion.

FIG. 17B depicts an imaging apparatus display which monitors treatment. Lesion is depicted on the imaging apparatus as is the aorta and renal artery. The image might depict heat, tissue elastography, vibrations, or might be based on a simulation of the position of the lesion. FIG. 17C depicts another view of the treatment monitoring, with the renal artery in cross section. Lesion is depicted in cross section in this image as well. The lesion might be considered to circumscribe the vessel in embodiments where multiple lesions are applied.

FIG. 17D depicts a methodology to analyze and follow the delivery of therapeutic focused ultrasound to an arterial region. A key step is to first position the patient optimally to image the treatment region; the imaging of the patient might involve the use of Doppler imaging, M mode imaging, A scan imaging, or even MRI or CT scan. The imaging unit is utilized to obtain coordinate data from the doppler shift pattern of the artery. Next, the focused ultrasound probe is positioned relative to the imaged treatment region and treatment can be planned or applied.

FIG. 17E depicts the pathway of the acoustic waves from a spherical or cylindrical type of ultrasound array. In some embodiments, the transducer is aspherical such that a

sharp focus does not exist but rather the focus is more diffuse in nature or off the central axis. Alternatively, the asphericity might allow for different pathlengths along the axis of the focusing. For example, one edge of the ultrasound transducer might be called upon for 15 cm of propagation while another edge of the transducer might be called upon to propagate only 10 cm, in which case a combination of difference frequencies or angles might be required.

Ultrasound transducers are aligned along the edge of a cylinder, aimed so that they intersect at one or more focal spots around the vessel (e.g. renal artery). The transducers are positioned along the cylinder or sphere or spherical approximation (e.g. aspherical) such that several of the transducers are closer to one focus or the other such that a range of distances to the artery is created. The patient and artery are positioned such that their centers co-localize with the center of the ultrasound array. Once the centers are co-localized, the HIFU energy can be activated to create lesions along the length of the artery wall at different depths and positions around the artery. The natural focusing of the transducers positioned along a cylinder as in FIG. 17E is a lengthwise lesion, longer than in thickness or height, which will run along the length of an artery when the artery is placed along the center axis of the cylinder. When viewed along a cross section (FIG. 17F), the nerve ablations are positioned along a clock face around the blood vessel.

In another embodiment, a movement system for the transducers is utilized so that the transducers move along the rim of the sphere or cylinder to which they are attached. The transducers can be moved automatically or semi-automatically, based on imaging or based on external position markers. The transducers are independently controlled electrically but coupled mechanically through the rigid structure.

Importantly, during treatment, a treatment workstation gives multiple views of the treatment zone with both physical appearance and anatomy. Physical modeling is performed in order to predict lesion depth and the time to produce the lesion; this information is fed back to the ultrasound transducers. The position of the lesion is also constantly monitored in a three dimensional coordinate frame and the transducer focus at lesions center in the context of monitoring continually updated.

In some embodiments, motion tracking prevents the lesion or patient from moving too far out of the treatment zone during the ablation. If the patient does move outside the treatment zone during the therapy, then the therapy can be stopped. Motion tracking can be performed using the ultrasound transducers, tracking frames and position or with transducers from multiple angles, creating a three dimensional image with the transducers. Alternatively, a video imaging system can be used to track patient movements, as can a series of accelerometers positioned on the patient which indicate movement.

FIG. 18 depicts a micro-catheter which can be placed into renal calyces; this catheter allows the operator to specifically ablate or stimulate regions of the kidney. The catheter can be used to further allow for targeting of the region around the renal arteries and kidneys by providing additional imaging capability or by assisting in movement tracking or reflection of the ultrasound waves to create or position the lesion. The catheter or device at or near the end of the catheter may transmit signals outside the patient to direct an energy delivery device which delivers energy through the skin. Signaling outside the patient may comprise energies such as radiofrequency transmission outside the patient or

radiofrequency from outside to the inside to target the region surrounding the catheter. The following patent and patent applications describe the delivery of ultrasound using a targeting catheter within a blood vessel, and are expressly incorporated by reference herein:

Ser. Nos. 11/583,569, 12/762,938, 11/583,656, 12/247,969, 10/633,726, 09/721,526, 10/780,405, 09/747,310, 12/202,195, 11/619,996, 09/696,076

In one system **8800**, a micro catheter **8810** is delivered to the renal arteries and into the branches of the renal arteries in the kidney **8820**. A signal is generated from the catheter into the kidney and out of the patient to an energy delivery system. Based on the generated signal, the position of the catheter in a three dimensional coordinate reference is determined and the energy source is activated to deliver energy **8830** to the region indicated by the microcatheter **8810**.

In an additional embodiment, station keeping is utilized. Station keeping enables the operator to maintain the position of the external energy delivery device with respect to the movement of the operator or movement of the patient. As an example, targeting can be achieved with the energy delivery system and

The microcatheter may be also be utilized to place a flow restrictor inside the kidney (e.g. inside a renal vein) to “trick” the kidney into thinking its internal pressure is higher than it might be. In this embodiment, the kidney generates signals to the central nervous system to lower sympathetic output to target organs in an attempt to decrease its perfusion pressure.

Alternatively, specific regions of the kidney might be responsible for hormone excretion or other factors which lead to hypertension or other detrimental effects to the cardiovascular system. The microcatheter can generate ultrasound, radiofrequency, microwave, or X-ray energy. The microcatheter can be utilized to ablate regions in the renal vein or intra-parenchymal venous portion as well. In some embodiments, ablation is not required but vibratory energy emanating from the probe is utilized to affect, on a permanent or temporary basis, the mechanoreceptors or chemoreceptors in the location of the hilum of the kidney.

FIG. **19A** depicts the application **8900** of energy to the region of the renal artery **8910** and kidney **8920** using physically separated transducers **8930**, **8931**. Although two are shown, the transducer can be a single transducer which is connected all along. The transducer(s) can be spherical or aspherical, they can be couple to an imaging transducer directly or indirectly where the imaging unit might be separated at a distance. In contrast to the delivery method of FIG. **17**, FIG. **19A** depicts delivery of ultrasound transverse to the renal arteries and not longitudinal to the artery. The direction of energy delivery is the posterior of the patient because the renal artery is the first vessel “seen” when traveling from the skin toward the anterior direction facilitating delivery of the therapy. In one embodiment, the transducers **8930**, **8931** are placed under, or inferior to the rib of the patient or between the ribs of a patient; next, the transducers apply an ultrasound wave propagating forward toward the anterior abdominal wall and image the region of the renal arteries and renal veins, separating them from one another. In some embodiments, such delivery might be advantageous, if for example, a longitudinal view of the artery is unobtainable or a faster treatment paradigm is desirable. The transducers **8930**, **8931** communicate with one another and are connected to a computer model of the region of interest being imaged (ROI), the ROI based on an MRI scan performed just prior to the start of the procedure and throughout the procedure. Importantly, the transducers are placed posterior in the cross section of the patient, an area with more direct access to the kidney region.

The angle between the imaging transducers can be as low as 3 degrees or as great as 180 degrees depending on the optimal position in the patient.

In another embodiment, an MRI is not performed but ultrasound is utilized to obtain all or part of the cross-sectional view in FIG. **19A**. For example, **8930** might contain an imaging transducer as well as a therapeutic energy source (e.g. ionizing energy, HIFU, low energy focused ultrasound, etc.)

FIG. **19B** depicts an ultrasound image from a patient illustrating imaging of the region with patient properly positioned as described below. It is this cross section that can be treated with image guided HIFU of the renal hilum region. The kidney **8935** is visualized in cross section and ultrasound then travels through to the renal artery **8937** and vein **8941**. The distance can be accurately measure **8943** with ultrasound (in this case 8 cm **8943**). This information is useful to help model the delivery of energy to the renal blood vessels.

FIG. **20** depicts an alternative method, system **9000** and device to ablate the renal nerves **9015** or the nerves leading to the renal nerves at the aorta-renal artery ostium **9010**. The intravascular device **9020** is placed into the aorta **9050** and advanced to the region of the renal arteries **9025**. Energy is applied from the transducer **9020** and focused **9040** (in the case of HIFU, LIFU, ionizing radiation) to the region of the takeoff of the renal arteries **9025** from the aorta **9050**. This intravascular **9030** procedure can be guided using MRI and/or MRI thermometry or it can be guided using fluoroscopy, ultrasound, or MRI. Because the aorta is larger than the renal arteries, the HIFU catheter can be placed into the aorta directly and cooling catheters can be included as well. In addition, in other embodiments, non-focused ultrasound can be applied to the region around the renal ostium or higher in the aorta. Non-focused ultrasound in some embodiments may require cooling of the tissues surrounding the probe using one or more coolants but in some embodiments, the blood of the aorta will take the place of the coolant, by its high flow rate; HIFU, or focused ultrasound, may not need the cooling because the waves are by definition focused from different angles to the region around the aorta. The vena cava and renal veins can also be used as a conduit for the focused ultrasound transducer to deliver energy to the region as well. In one embodiment, the vena cava is accessed and vibratory energy is passed through the walls of the vena cava and renal vein to the renal arteries, around which the nerves to the kidney travel. The veins, having thinner walls, allow energy to pass through more readily.

FIG. **21a-b** depicts an eyeball **9100**. Also depicted are the zonules of the eye **9130** (the muscles which control lens shape) and ultrasound transducer **9120**. The transducer **9120** applies focused ultrasound energy to the region surrounding the zonules, or the zonules themselves, in order to tighten them such that a presbyopic patient can accommodate and visualize object up close. Similarly, heat or vibration applied to the ciliary muscles, which then increases the outflow of aqueous humor at the region of interest so that the pressure within the eye cannot build up to a high level. The ultrasound transducer **9120** can also be utilized to deliver drug therapy to the region of the lens **9150**, ciliary body, zonules, intra-vitreous cavity, anterior cavity **9140**, posterior cavity, etc.

In some embodiments (FIG. **21b**), multiple transducers **9160** are utilized to treat tissues deep within the eye; the ultrasonic transducers **9170** are focused on the particular region of the eye from multiple directions so that tissues along the path of the ultrasound are not damaged by the ultrasound and the focus region and region of effect **9180** is the position where the waves meet in the eye. In one embodiment, the transducers are directed through the pars plana region of the

eye to target the macula **9180** at the posterior pole **9175** of the eye. This configuration might allow for heat, vibratory stimulation, drug delivery, gene delivery, augmentation of laser or ionizing radiation therapy, etc. In certain embodiments, focused ultrasound is not required and generic vibratory waves are transmitted through the eye at frequencies from 20 kHz to 10 MHz. Such energy may be utilized to break up clots in, for example, retinal venous or arterial occlusions which are creating ischemia in the retina. This energy can be utilized in combination with drugs utilized specifically for breaking up clots in the veins of the retina.

FIG. **22** depicts a peripheral joint **9200** being treated with heat and/or vibrational energy. Ultrasound transducer **9210** emits waves toward the knee joint to block nerves **9260** just underneath the bone periosteum **92209250** or underneath the cartilage. Although a knee joint is depicted, it should be understood that many joints can be treated including small joints in the hand, intervertebral joints, the hip, the ankle, the wrist, and the shoulder. Unfocused or focused ultrasonic energy can be applied to the joint region to inhibit nerve function reversibly or irreversibly. Such inhibition of nerve function can be utilized to treat arthritis, post-operative pain, tendonitis, tumor pain, etc. In one preferred embodiment, vibratory energy can be utilized rather than heat. Vibratory energy applied to the joint nerves can inhibit their functioning such that the pain fibers are inhibited.

FIG. **23a-b** depicts closure of a fallopian tube **9300** of a uterus **9320** using externally applied ultrasound **9310** so as to prevent pregnancy. MRI or preferably ultrasound can be utilized for the imaging modality. Thermometry can be utilized as well so as to see the true ablation zone in real time. The fallopian tube **9300** can be visualized using ultrasound, MRI, CT scan or a laparoscope. Once the fallopian tube is targeted, external energy **9310**, for example, ultrasound, can be utilized to close the fallopian tube to prevent pregnancy. When heat is applied to the fallopian tube, the collagen in the walls are heated and will swell, the walls then contacting one another and closing the fallopian preventing full ovulation and therefore preventing pregnancy. Although there is no doppler signal in the fallopian tube, the technology for visualization and treatment is similar to that for an artery or other duct. That is, the walls of the tube are identified and modeled, then focused ultrasound is applied through the skin to the fallopian tube to apply heat to the walls of the lumen of the fallopian tube.

In FIG. **23b**, a method is depicted in which the fallopian tubes are visualized **9340** using MRI, CT, or ultrasound. HIFU **9350** is applied under visualization with MRI or ultrasound. As the fallopian tubes are heated, the collagen in the wall is heated until the walls of the fallopian tube close off. At this point the patient is sterilized **9360**. During the treating time, it may be required to determine how effective the heating is progressing. If additional heat is required, then additional HIFU may be added to the fallopian tubes until there is closure of the tube and the patient is sterilized **9360**. Such is one of the advantages of the external approach in which multiple treatments can be applied to the patient, each treatment closing the fallopian tubes further, the degree of success then assessed after each treatment. A further treatment can then be applied **9370**.

In other embodiments, ultrasound is applied to the uterus or fallopian tubes to aid in pregnancy by improving the receptivity of the sperm and/or egg for one another. This augmentation of conception can be applied to the sperm and egg outside of the womb as well, for example, in a test tube in the case of extra-uterine fertilization.

FIG. **24** depicts a feedback algorithm to treat the nerves of the autonomic nervous system. It is important that there be an

assessment of the response to the treatment afterward. Therefore, in a first step, modulation of the renal nerves **9400** is accomplished by any or several of the embodiments discussed above. An assessment **9410** then ensues, the assessment determining the degree of treatment effect engendered; if a complete or satisfactory response is determined **9420**, then treatment is completed. For example, the assessment **9410** might include determination through microneurography, assessment of the carotid sinus reactivity (described above), heart rate variability, measurement of norepinephrine levels, etc. With a satisfactory autonomic response, further treatment might not ensue or depending on the degree of response, additional treatments of the nerves **9430** may ensue.

FIG. **25** depicts a reconstruction of a patient from CT scan images showing the position of the kidneys **9520** looking through the skin of a patient **9500**. The ribs **9510** partially cover the kidney but do reveal a window at the inferior pole **9530** of the kidney **9520**. Analysis of many of these reconstructions has led to clinical paradigm in which the ribs **9510**, pelvis **9420**, and the vertebra **9440** are identified on a patient, the kidneys are identified via ultrasound and then renal arteries are identified via Doppler ultrasound.

As shown in FIG. **26a**, once the ribs and vertebra are identified with the Doppler ultrasound, an external energy source **9600** can be applied to the region. Specifically, focused ultrasound (HIFU or LIFU) can be applied to the region once these structures are identified and a lesion applied to the blood vessels (renal artery and renal nerve) **9620** leading to the kidney **9610**. As described herein, the position of the ultrasound transducer **9600** is optimized on the posterior of the patient as shown in FIG. **26A**. That is, with the vertebra, the ribs, and the iliac crest bordering the region where ultrasound is applied.

Based on the data above and specifically the CT scan anatomic information in FIG. **26A**, FIG. **26B** depicts a device and system **9650** designed for treatment of this region (blood vessels in the hilum of the kidney) in a patient. It contains a 0.5-3 Mhz ultrasound imaging transducer **9675** in its center and a cutout or attachment location of the ultrasound ceramic (e.g. PZT) for the diagnostic ultrasound placement. It also contains a movement mechanism **9660** to control the therapeutic transducer **9670**. The diagnostic ultrasound device **9675** is coupled to the therapeutic device in a well-defined, known relationship. The relationship can be defined through rigid or semi-rigid coupling or it can be defined by electrical coupling such as through infrared, optical-mechanical coupling and/or electro-mechanical coupling. Along the edges of the outer rim of the device, smaller transducers **9670** can be placed which roughly identify tissues through which the ultrasound travels. For example, simple and inexpensive one or two-dimensional transducers might be used so as to determine the tissues through which the ultrasound passes on its way to the target can be used for the targeting and safety. From a safety perspective, such data is important so that the ultrasound does not hit bone or bowel and that the transducer is properly placed to target the region around the renal blood vessels. Also included in the system is a cooling system to transfer heat from the transducer to fluid **9662** running through the system. Cooling via this mechanism allows for cooling of the ultrasound transducer as well as the skin beneath the system. A further feature of the system is a sensor mechanism **9665** which is coupled to the system **9650** and records movement of the system **9650** relative to a baseline or a coordinate nearby. In one embodiment, a magnetic sensor is utilized in which the sensor can determine the orientation of the system relative to a magnetic sensor on the system. The

sensor **9665** is rigidly coupled to the movement mechanism **9660** and the imaging transducer **9675**. In addition to magnetic, the sensor might be optoelectric, acoustic, or radiofrequency based.

Furthermore, the face **9672** of the transducer **9670** is shaped such that it fits within the bony region described and depicted in FIG. **26A**. For example, the shape might be elliptical or aspheric or in some cases spheric. In addition, in some embodiments the ultrasound imaging engine might not be directly in the center of the device and in fact might be superior to the center and closer to the superior border of the face and closer to the ribs, wherein the renal artery is visualized better with the imaging probe **9675**.

Given the clinical data as well as the devised technologies described above (e.g. FIG. **26A-B**), FIG. **27** illustrates the novel treatment plan **9700** to apply energy to the nerves around the renal artery with energy delivered from a position external to the patient.

In one embodiment, the patient is stabilized and/or positioned such that the renal artery and kidneys are optimally located **9710**. Diagnostic ultrasound **9730** is applied to the region and optionally, ultrasound is applied from a second direction **9715**. The positioning and imaging maneuvers allow the establishment of the location of the renal artery, the hilum, and the vein **9720**. A test dose of therapeutic energy **9740** can be applied to the renal hilum region. In some embodiments, temperature **9735** can be measured. This test dose can be considered a full dose if the treatment is in fact effective by one or more measures. These measures might be blood pressure **9770**, decrease in sympathetic outflow (as measured by microneurography **9765**), increase in parasympathetic outflow, change in the caliber of the blood vessel **9755** or a decrease in the number of spontaneous spikes in a microneurographic analysis in a peripheral nerve (e.g. peroneal nerve) **9765**, or an MRI or CT scan which reveals a change in the nervous anatomy **9760**. In some embodiments, indices within the kidney are utilized for feedback. For example, the resistive index, a measure of the vasoconstriction in the kidney measured by doppler ultrasound is a useful index related to the renal nerve activity; for example, when there is greater autonomic activity, the resistive index increases, and vice versa.

Completion of the treatment **9745** might occur when the blood pressure reaches a target value **9770**. In fact, this might never occur or it may occur only after several years and treatment. The blood pressure might continually be too high and multiple treatments may be applied over a period of years . . . the concept of dose fractionation. Fractionation is a major advantage of applying energy from a region external to a region around the renal arteries in the patient as it is more convenient and less expensive when compared to invasive treatments such as stimulator implantation and interventional procedures such as catheterization of the renal artery.

Another important component is the establishment of the location and position of the renal artery, renal vein, and hilum of the kidney **9720**. As discussed above, the utilization of Doppler ultrasound signaling allows for the position of the nerves to be well approximated such that the ultrasound can be applied to the general region of the nerves. The region of the nerves can be seen in FIGS. **29A-D**. FIGS. **29A-C** are sketches from actual histologic slices. The distances from the arterial wall can be seen at different locations and generally range from 0.3 mm to 10 mm. Nonetheless, these images are from actual renal arteries and nerves and are used so as to develop the treatment plan for the system. For example, once the arterial wall is localized **9730** using the Doppler or other ultrasound signal, a model of the position of the nerves can be

established and the energy then targeted to that region to inhibit the activity of the nerves **9720**. Notably, the distance of many of these nerves from the wall of the blood vessel indicate that a therapy which applies radiofrequency to the wall of the vessel from the inside of the vessel likely has great difficulty in reaching a majority of the nerves around the blood vessel wall.

FIG. **29D** depicts a schematic from a live human ultrasound. As can be seen, the ultrasound travels through skin, through the subcutaneous fat, through the muscle and at least partially through the kidney **8935** to reach the hilum **8941** of the kidney and the renal blood vessels **8937**. This direction was optimized through clinical experimentation so as to not include structures which tend to scatter ultrasound such as bone and lung. Experimentation lead to the optimization of this position for the imaging and therapy of the renal nerves. The position of the ultrasound is between the palpable bony landmarks on the posterior of the patient as described above and below. The vertebrae are medial, the ribs superior and the iliac crest inferior. Importantly, the distance of these structures **8943** is approximately 8-12 cm and not prohibitive from a technical standpoint. These images from the ultrasound are therefore consistent with the results from the CT scans described above as well.

FIG. **29E** depicts the surface area **8760** available to an ultrasound transducer for two patients out of a clinical study. One patient was obese and the other thinner. Quantification of this surface area **8762** was obtained by the following methodology: 1) obtain CT scan; 2) mark off boundary of organs such as the vertebrae, iliac crest, and ribs; 3) draw line from renal blood vessels to the point along the edge of the bone; 4) draw perpendicular from edge bone to the surface of the skin; 5) map the collection of points obtained along the border of the bone. The surface area is the surface area between the points and the maximum diameter is the greatest distance between the bony borders. The collection of points obtained with this method delimits the area on the posterior of the patient which is available to the ultrasound transducer to either visualize or treat the region of the focal spot. By studying a series of patients, the range of surface areas was determined so as to assist in the design which will serve the majority of patients. The transducers modeled in FIG. **30** have surface areas of approximately 11x8 cm or 88 cm² which is well within the surface area shown in FIG. **29E** **8762** which is representative of a patient series. Further more the length, or distance, from the renal artery to the skin was quantified in shortest ray **8764** and longest ray **8766**. Along with the angular data presented above, these data enable design of an appropriate transducer to achieve autonomic modulation and control of blood pressure.

In a separate study, it was shown that these nerves could be inhibited using ultrasound applied externally with the parameters and devices described herein. Pathologic analysis revealed that the nerves around the artery were completely inhibited and degenerated, confirming the ability of the treatment plan to inhibit these nerves and ultimately to treat diseases such as hypertension. Furthermore, utilizing these parameters, did not cause any damage within the path of the ultrasound through the kidney and to the renal hilum.

Importantly, it has also been discovered via clinical trials that when ultrasound is used as the energy applied externally, that centering the diagnostic ultrasound probe such that a cross section of the kidney is visualized and the vessels are visualized, is an important component of delivering the therapy to the correct position along the blood vessels. One of the first steps in the algorithm **9700** is to stabilize the patient in a patient stabilizer custom built to deliver energy to the

region of the renal arteries. After stabilization of the patient, diagnostic ultrasound is applied to the region **9730** to establish the extent of the ribs, vertebrae, and pelvis location. Palpation of the bony landmarks also allows for the demarcation of the treatment zone of interest. The external ultrasound system is then placed within these regions so as to avoid bone. Then, by ensuring that a portion of the external energy is delivered across the kidney (for example, using ultrasound for visualization), the possibility of hitting bowel is all but eliminated. The ultrasound image in FIG. **29D** depicts a soft tissue path from outside the patient to the renal hilum inside the patient. The distance is approximately 8-16 cm. Once the patient is positioned, a cushion **9815** is placed under the patient. In one embodiment, the cushion **9815** is simply a way to prop up the back of the patient. In another embodiment, the cushion **9815** is an expandable device in which expansion of the device is adjustable for the individual patient. The expandable component **9815** allows for compression of the retroperitoneum (where the kidney resides) to slow down or dampen movement of the kidney and maintain its position for treatment with the energy source or ultrasound.

A test dose of energy **9740** can be given to the region of the kidney hilum or renal artery and temperature imaging **9735**, constriction of blood vessels **9755**, CT scans **9760**, microneurography **9765** patch or electrode, and even blood pressure **9770**. Thereafter, the treatment can be completed **9745**. Completion might occur minutes, hours, days, or years later depending on the parameter being measured.

Through experimentation, it has been determined that the region of the renal hilum and kidneys can be stabilized utilizing gravity with local application of force to the region of the abdomen below the ribs and above the renal pelvis. For example, FIGS. **28A-C** depict examples of patient positioners intended to treat the region of the renal blood vessels.

FIG. **28A** is one example of a patient positioned in which the ultrasound diagnostic and therapeutic **9820** is placed underneath the patient. The positioner **9810** is in the form of a tiltable bed. A patient elevator **9815** placed under the patient pushes the renal hilum closer to the skin and can be pushed forward in this manner; as determined in clinical trials, the renal artery is approximately 2-3 cm more superficial in this type of arrangement with a range of approximately 7-15 cm in the patients studied within the clinical trial. The weight of the patient allows for some stabilization of the respiratory motion which would otherwise occur; the patient elevator can be localized to one side or another depending on the region to be treated.

FIG. **28B** detects a more detailed configuration of the ultrasound imaging and therapy engine **9820** inset. A patient interface **9815** is utilized to create a smooth transition for the ultrasound waves to travel through the skin and to the kidneys for treatment. The interface is adjustable such that it is customizable for each patient.

FIG. **28C** depicts another embodiment of a positioner device **9850**, this time meant for the patient to be face down. In this embodiment, the patient is positioned in the prone position lying over the patient elevator **9815**. Again, through clinical experimentation, it was determined that the prone position with the positioner under the patient pushes the renal hilum posterior and stretches out the renal artery and vein allowing them to be more visible to ultrasound and accessible to energy deposition in the region. The positioner underneath the patient might be an expandable bladder with one or more compartments which allows for adjustability in the amount of pressure applied to the underside of the patient. The positioner might also have a back side which is expandable **9825**

and can push against the posterior side of the patient toward the expandable front side of the positioner thereby compressing the stretched out renal blood vessels to allow for a more superficial and easier application of the energy device. These data can be seen in FIGS. **7G** and **7H** where the renal artery is quite a bit closer to the skin (7-17 cm down to 6-10 cm). The position of the energy devices for the left side **9827** of the patient and right side **9828** of the patient are depicted in FIG. **28C**. The ribs **9829** delimit the upper region of the device placement and the iliac crest **9831** delimits the lower region of the device placement. The spinous processes **9832** delimit the medial edge of the region where the device can be placed and the region between **9828** is the location where the therapeutic transducer is placed.

The table elevation is on the front side of the patient, pushing upward toward the renal hilum and kidneys. The head of the table may be dropped or elevated so as to allow specific positioning positions. The elevated portion may contain an inflatable structure which controllably applies pressure to one side or another of the torso, head, or pelvis of the patient.

FIG. **29A-C** depicts the anatomical basis **9900** of the targeting approach described herein. These figures are derived directly from histologic slides. Nerves **9910** can be seen in a position around renal artery **9920**. The range of radial distance from the artery is out to 2 mm and even out to 10 mm. Anatomic correlation with the modeling in FIG. **16B** reveals the feasibility of the targeting and validates the approach based on actual pathology; that is, the approach of applying therapy to the renal nerves by targeting the adventitia of the artery. This is important because the methodology used to target the nerves is one of detecting the Doppler signal from the artery and then targeting the vessel wall around the doppler signal. Nerves **9910** can be seen surrounding the renal artery **9920** which puts them squarely into the temperature field shown in **16B** indicating the feasibility of the outlined targeting approach in FIG. **27** and the lesion configuration in FIG. **16A**. Further experimentation (utilizing similar types of pathology as well as levels of norepinephrine in the kidney) reveals that the required dose of ultrasound to the region to affect changes in the nerves is on the order of 100 W/cm² for partial inhibition of the nerves and 1-2 kW/cm² for complete inhibition and necrosis of the nerves. These doses or doses in between them might be chosen depending on the degree of nerve inhibition desired in the treatment plan. Importantly, it was further discovered through the experimentation that an acoustic plane through the blood vessels was adequate to partially or completely inhibit the nerves in the region. That is to say, that a plane through which the blood vessels travels perpendicularly is adequate to ablate the nerves around the artery as illustrated in FIG. **16B**. Until this experimentation, there had been no evidence that ultrasound would be able to inhibit nerves surrounding an artery by applying a plane of ultrasound through the blood vessel. Indeed, it was proven that a plane of ultrasound essentially could circumferentially inhibit the nerves around the blood vessel.

FIGS. **30A-I** depict three dimensional simulations from a set of CT scans from the patient model shown in FIG. **26A**. Numerical simulations were performed in three dimensions with actual human anatomy from the CT scans. The same CT scans utilized to produce FIGS. **7E**, **19**, and **25** were utilized to simulate a theoretical treatment of the renal artery region considering the anatomy of a real patient. Utilizing the doses shown in the experimentation above (FIGS. **29A-D**) combined with the human anatomy from the CT scans, it is shown with these simulations that the ability exists to apply therapeutic ultrasound to the renal hilum from a position outside

the patient. In combination with FIG. 29, which as discussed, depicts the position of the nerves around the blood vessels as well as the position of the vessels in an ultrasound, FIG. 30A-I depicts the feasibility of an ultrasound transducer which is configured to apply the required energy to the region of the hilum of the kidney without damaging intervening structures. These simulations are in fact confirmation for the proof of concept for this therapy and incorporate the knowledge obtained from the pathology, human CT scans, human ultrasound scans, and the system designs presented previously above.

In one embodiment, FIG. 30A, the maximum intensity is reached at the focus 10010 is approximately 186 W/cm² with a transducer 10000 design at 750 MHz; the transducer is approximately 11×8 cm with a central portion 10050 for an ultrasound imaging engine. The input wattage to the transducer is approximately 120 W-150 W depending on the specific patient anatomy.

FIGS. 30B and 30C depict the acoustic focus 10020, 10030 at a depth of approximately 9-11 cm and in two dimensions. Importantly, the region (tissues such as kidney, ureter, skin, muscle) proximal (10040 and 10041) to the focus 10020, 10030 do not have any significant acoustic power absorption indicating that the treatment can be applied safely to the renal artery region through these tissues as described above. Importantly, the intervening tissues are not injured in this simulation indicating the feasibility of this treatment paradigm.

FIGS. 30D-F depict a simulation with a transducer 10055 having a frequency of approximately 1 MHz. With this frequency, the focal spot 10070, 10040, 10050 size is a bit smaller (approximately 2 cm by 0.5 cm) and the maximum power higher at the focus, approximately 400 W/cm² than shown in FIGS. 30A-C. In the human simulation, this is close to an optimal response and dictates the design parameters for the externally placed devices. The transducer in this design is a rectangular type of design (spherical with the edges shaved off) so as to optimize the working space in between the posterior ribs of the patient and the superior portion of the iliac crest of the patient. Its size is approximately 11 cm×8 cm which as described above and below is well within the space between the bony landmarks of the back of the patient.

FIGS. 30G-I depict a simulation with similar ultrasound variables as seen in FIGS. 30D-F. The difference is that the transducer 10090 was left as spherical with a central cutout rather than rectangular with a central cutout. The spherical transducer setup 10090 allows for a greater concentration of energy at the focus 1075 due to the increased surface area of vibratory energy. Indeed, the maximum energy from this transducer (FIG. 30G) is approximately 744 W/cm² whereas for the transducer in FIG. 30d, the maximum intensity is approximately 370 W/cm². FIG. 30H depicts one plane of the model and 30I another plane. Focus 10080, 10085 is depicted with intervening regions 10082 and 10083 free from acoustic power and heat generation, similar to FIG. 30A-F.

These simulations confirm the feasibility of a therapeutic treatment of the renal sympathetic nerves from the outside without damage to intervening tissues or structures such as bone, bowel, and lung. Hypertension is one clinical application of this therapy. A transducer with an imaging unit within is utilized to apply focused ultrasound to a renal nerve surrounding a renal artery. Both the afferent nerves and efferent nerves are affected by this therapy.

Other transducer configurations are possible. Although a single therapeutic transducer is shown in FIG. 30A-I, configurations such as phased array therapy transducers (more than one independently controlled therapeutic transducer) are possible. Such transducers allow more specific tailoring to the

individual patient. For example, a larger transducer might be utilized with 2, 3, 4 or greater than 4 transducers. Individual transducers might be turned on or off depending on the patients anatomy. For example, a transducer which would cover a rib in an individual patient might be turned off during the therapy.

Although the central space is shown in the center of the transducer in FIGS. 30A-I, the imaging transducer might be placed anywhere within the field as long as its position is well known relative to the therapy transducers. For example, insofar as the transducer for therapy is coupled to the imaging transducer spatially in three dimensional space and this relationship is always known, the imaging transducer can be in any orientation relative to the therapeutic transducer.

The invention claimed is:

1. A method of inhibiting a nerve surrounding a blood vessel in a patient comprising:

placing an intravascular catheter inside the blood vessel in the patient, the catheter comprising a piezoelectric component; and

energizing the piezoelectric component to deliver unfocused ultrasound energy towards at least a majority portion of a circumference of the blood vessel to thereby reach the nerve surrounding the blood vessel;

wherein the act of energizing is performed to create a heated region having a toroidal configuration.

2. The method of claim 1, wherein the unfocused ultrasound energy is low intensity ultrasound.

3. The method of claim 1, wherein the unfocused ultrasound energy has an energy level that is anywhere from 50 mW/cm² to 1000 mW/cm².

4. The method of claim 1, wherein the unfocused ultrasound energy comprises cavitating energy.

5. The method of claim 1, further comprising delivering a bioactive agent to the nerve surrounding the blood vessel prior to delivering the unfocused ultrasound energy.

6. The method of claim 1, further comprising determining a degree of heat resulted from the delivery of the unfocused ultrasound energy.

7. The method of claim 1, further comprising determining a temperature of the nerve surrounding the blood vessel during the delivery of the unfocused ultrasound energy.

8. The method of claim 7, wherein the temperature is determined using a MRI scanner.

9. The method of claim 8, wherein the temperature is maintained between 40 and 60 degrees Celsius.

10. The method of claim 1, wherein the unfocused ultrasound energy is delivered so that a temperature of the nerve is anywhere from 40 to 60 degrees Celsius.

11. The method of claim 1, further comprising performing an imaging procedure during the delivery of the unfocused ultrasound energy, wherein the imaging procedure is performed on a part of the patient using an ultrasound imaging device positioned external to the patient.

12. The method of claim 1, wherein the intravascular catheter further comprises a cooling mechanism to protect an interior surface of the blood vessel.

13. The method of claim 1, wherein the intravascular catheter further comprises a stabilization mechanism for stabilizing a part of the intravascular catheter relative to the blood vessel.

14. The method of claim 1, wherein the unfocused ultrasound energy inhibits the nerve with vibration and not by heating the nerve.

15. The method of claim 1, further comprising detecting the unfocused ultrasound energy using a component placed external to the patient.

55

16. The method of claim 1, further comprising:
detecting the unfocused ultrasound energy by an external
component; and
using the detected ultrasonic energy to facilitate treatment
targeting.

17. The method of claim 1, wherein the unfocused ultra-
sound energy radiates outward from the intravascular catheter
to intersect an interior wall of the blood vessel to thereby
create the heated region having the toroidal configuration.

18. The method of claim 1, further comprising utilizing a
device to detect a progress of the delivery of the ultrasound
energy.

19. The method of claim 1, wherein the catheter further
comprises a material which facilitates transmission of the
unfocused ultrasound energy to a wall of the blood vessel.

20. The method of claim 1, wherein the blood vessel is a
renal artery, and the nerve comprises a renal nerve.

21. The method of claim 1, further comprising detecting
signals from an autonomic nervous system of the patient prior
to, and after, the act of energizing.

22. A method to inhibit a renal nerve traveling to a kidney
in a patient comprising:
inserting an intravascular catheter into a renal artery of the
patient;
delivering energy from the intravascular catheter to the
renal nerve around the artery;

56

utilizing a device to detect a progress of the delivery of the
energy to the nerve;

wherein the act of delivering energy is performed to create
a heated region having a toroidal configuration.

23. The method of claim 22, wherein the energy comprises
ultrasound.

24. The method of claim 22, wherein the energy comprises
unfocused ultrasound.

25. The method of claim 22, wherein the energy comprises
radiofrequency energy.

26. The method of claim 22, wherein the energy comprises
vibrational energy.

27. The method of claim 22, wherein the energy comprises
cavitational energy.

28. The method of claim 22, wherein the progress is
detected by measuring a temperature with the device.

29. The method of claim 22, wherein the progress is
detected by measuring a tissue response using the device.

30. The method of claim 22, wherein the energy is deliv-
ered to heat the renal nerve to a temperature that is anywhere
from 40 to 60 degrees Celsius.

31. The method of claim 30, further comprising detecting
the temperature using the device.

* * * * *

专利名称(译)	血管内导管将未聚焦的能量传递给血管周围的神经		
公开(公告)号	US9358401	公开(公告)日	2016-06-07
申请号	US13/417194	申请日	2012-03-09
申请(专利权)人(译)	KONA MEDICAL , INC.		
当前申请(专利权)人(译)	KONA MEDICAL , INC.		
[标]发明人	GERTNER MICHAEL		
发明人	GERTNER, MICHAEL		
IPC分类号	A61B8/14 A61N5/00 A61B18/14 A61B18/18 A61B17/32 A61N7/02 A61N7/00 A61N5/06 A61B8/08 A61B8/06 A61B8/00 A61B5/00 A61N1/05 A61B5/055 A61N2/00 A61B18/00 A61B6/00 A61B6/03 A61B5/0225		
CPC分类号	A61B18/14 A61B18/18 A61N1/0551 A61N5/00 A61N5/0601 A61N5/062 A61N5/0622 A61N7/00 A61N7/02 A61B6/037 A61B8/00 A61B8/06 A61B8/08 A61B17/320068 A61N2/006 A61B5/055 A61B5/4035 A61B5/4041 A61B5/4047 A61B5/412 A61B5/489 A61B5/4839 A61B5/4893 A61B6/032 A61N2007/003 A61N2007/0026 A61N2007/0078 A61B5/0225 A61B5/4052 A61B5/4528 A61B6/03 A61B6/506 A61B8/4245 A61B8/485 A61B2018/00404 A61B2018/00434 A61B2018/00511 A61B2090/3762 A61B2090/374 A61B2090/378 A61N2005/063		
优先权	61/377908 2010-08-27 US 61/347375 2010-05-21 US 61/256983 2009-10-31 US 61/250857 2009-10-12 US 61/261741 2009-11-16 US 61/291359 2009-12-30 US 61/303307 2010-02-10 US		
其他公开文献	US20120172723A1		
外部链接	Espacenet USPTO		

摘要(译)

在一些实例中，围绕动脉或导致器官的神经被能量源靶向以校正或调节生理过程。在一些示例中，不同类型的能量源被单独使用或彼此组合使用。在一些实例中，由能量源激活的生物活性剂或装置被递送至感兴趣的区域，并且通过这些试剂增强能量，或者通过能量源增强试剂。

