



US008048040B2

(12) **United States Patent**
Kiani

(10) **Patent No.:** **US 8,048,040 B2**
(45) **Date of Patent:** **Nov. 1, 2011**

- (54) **FLUID TITRATION SYSTEM**
- (75) Inventor: **Massi E. Kiani**, Laguna Niguel, CA (US)
- (73) Assignee: **Masimo Corporation**, Irvine, CA (US)
- (*) Notice: Subject to any disclaimer, the term of this patent is extended or adjusted under 35 U.S.C. 154(b) by 151 days.
- (21) Appl. No.: **12/208,998**
- (22) Filed: **Sep. 11, 2008**
- (65) **Prior Publication Data**
US 2009/0076462 A1 Mar. 19, 2009

D353,195 S	12/1994	Savage et al.
D353,196 S	12/1994	Savage et al.
5,377,676 A	1/1995	Vari et al.
D359,546 S	6/1995	Savage et al.
5,431,170 A	7/1995	Mathews
D361,840 S	8/1995	Savage et al.
D362,063 S	9/1995	Savage et al.
5,452,717 A	9/1995	Branigan et al.
D363,120 S	10/1995	Savage et al.
5,456,252 A	10/1995	Vari et al.
5,482,036 A	1/1996	Diab et al.
5,490,505 A	2/1996	Diab et al.
5,494,043 A	2/1996	O'Sullivan et al.
5,533,511 A	7/1996	Kaspari et al.
5,561,275 A	10/1996	Savage et al.
5,562,002 A	10/1996	Lalin
5,590,649 A	1/1997	Caro et al.
5,602,924 A	2/1997	Durand et al.
5,632,272 A	5/1997	Diab et al.
5,638,816 A	6/1997	Kiani-Azarbayjany et al.
5,638,818 A	6/1997	Diab et al.

(Continued)

Related U.S. Application Data

- (60) Provisional application No. 60/993,584, filed on Sep. 13, 2007.
- (51) **Int. Cl.**
A61M 5/00 (2006.01)
A61B 5/00 (2006.01)
- (52) **U.S. Cl.** 604/246; 600/310
- (58) **Field of Classification Search** 604/246, 604/66; 600/310
See application file for complete search history.

Primary Examiner — Kevin C Simons
Assistant Examiner — Michael J Anderson
(74) *Attorney, Agent, or Firm* — Knobbe, Martens, Olson & Bear LLP

(57) **ABSTRACT**

A fluid titration system has an optical sensor, a physiological monitor, a titration controller and an infusion device. The optical sensor transmits multiple wavelengths of light into a tissue site of a person and detects the optical radiation after attenuation by pulsatile blood flowing within the tissue site. The physiological monitor receives a resulting sensor signal and derives a plethysmograph that corresponds to the pulsatile blood flow. The monitor also calculates a plethysmograph variability measure that is responsive to changes in perfusion at the tissue site. A titration controller generates a fluid control output according to the variability measure. The infusion device administers a liquid solution via an intravenous (IV) connection to the person according to the fluid control output so as to regulate at least one of a fluid flow start, rate and stop.

20 Claims, 8 Drawing Sheets

(56) **References Cited**

U.S. PATENT DOCUMENTS

4,109,643 A *	8/1978	Bond et al.	600/479
4,960,128 A	10/1990	Gordon et al.	
4,964,408 A	10/1990	Hink et al.	
5,041,187 A	8/1991	Hink et al.	
5,069,213 A	12/1991	Polczynski	
5,111,817 A *	5/1992	Clark et al.	600/323
5,163,438 A	11/1992	Gordon et al.	
5,337,744 A	8/1994	Branigan	
5,341,805 A	8/1994	Stavridi et al.	

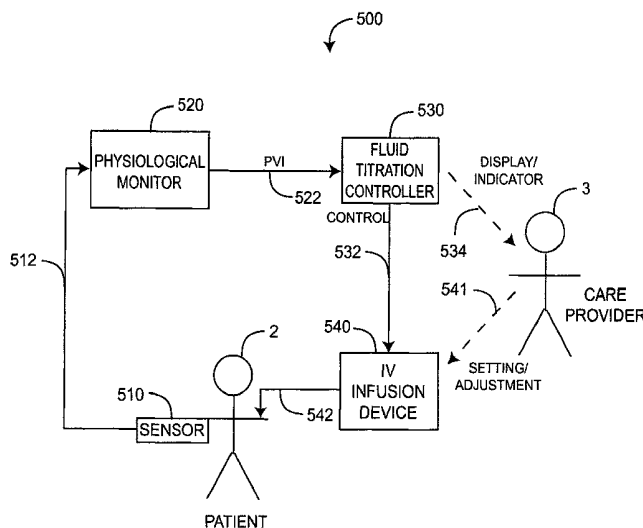

U.S. PATENT DOCUMENTS							
5,645,440	A	7/1997	Tobler et al.	6,639,668	B1	10/2003	Trepagnier
5,685,299	A	11/1997	Diab et al.	6,640,116	B2	10/2003	Diab
D393,830	S	4/1998	Tobler et al.	6,643,530	B2	11/2003	Diab et al.
5,743,262	A	4/1998	Lepper, Jr. et al.	6,650,917	B2	11/2003	Diab et al.
5,758,644	A	6/1998	Diab et al.	6,654,624	B2	11/2003	Diab et al.
5,760,910	A	6/1998	Lepper, Jr. et al.	6,658,276	B2	12/2003	Diab et al.
5,766,127	A	* 6/1998	Pologe et al. 600/310	6,661,161	B1	12/2003	Lanzo et al.
5,769,785	A	6/1998	Diab et al.	6,671,531	B2	12/2003	Al-Ali et al.
5,782,757	A	7/1998	Diab et al.	6,678,543	B2	1/2004	Diab et al.
5,785,659	A	7/1998	Caro et al.	6,684,090	B2	1/2004	Ali et al.
5,791,347	A	8/1998	Flaherty et al.	6,684,091	B2	1/2004	Parker
5,810,734	A	9/1998	Caro et al.	6,697,656	B1	2/2004	Al-Ali
5,823,950	A	10/1998	Diab et al.	6,697,657	B1	2/2004	Shehada et al.
5,830,131	A	11/1998	Caro et al.	6,697,658	B2	2/2004	Al-Ali
5,833,618	A	11/1998	Caro et al.	RE38,476	E	3/2004	Diab et al.
5,860,919	A	1/1999	Kiani-Azarbayjany et al.	6,699,194	B1	3/2004	Diab et al.
5,890,929	A	4/1999	Mills et al.	6,714,804	B2	3/2004	Al-Ali et al.
5,904,654	A	5/1999	Wohlmann et al.	RE38,492	E	4/2004	Diab et al.
5,919,134	A	7/1999	Diab	6,721,582	B2	4/2004	Trepagnier et al.
5,934,925	A	8/1999	Tobler et al.	6,721,585	B1	4/2004	Parker
5,940,182	A	8/1999	Lepper, Jr. et al.	6,725,075	B2	4/2004	Al-Ali
5,995,855	A	11/1999	Kiani et al.	6,728,560	B2	4/2004	Kollias et al.
5,997,343	A	12/1999	Mills et al.	6,735,459	B2	5/2004	Parker
6,002,952	A	12/1999	Diab et al.	6,745,060	B2	6/2004	Diab et al.
6,011,986	A	1/2000	Diab et al.	6,760,607	B2	7/2004	Al-Ali
6,027,452	A	2/2000	Flaherty et al.	6,770,028	B1	8/2004	Ali et al.
6,036,642	A	3/2000	Diab et al.	6,771,994	B2	8/2004	Kiani et al.
6,045,509	A	4/2000	Caro et al.	6,792,300	B1	9/2004	Diab et al.
6,067,462	A	5/2000	Diab et al.	6,813,511	B2	11/2004	Diab et al.
6,081,735	A	6/2000	Diab et al.	6,816,741	B2	11/2004	Diab
6,088,607	A	7/2000	Diab et al.	6,822,564	B2	11/2004	Al-Ali
6,110,522	A	8/2000	Lepper, Jr. et al.	6,826,419	B2	11/2004	Diab et al.
6,124,597	A	9/2000	Shehada	6,830,711	B2	12/2004	Mills et al.
6,144,868	A	11/2000	Parker	6,850,787	B2	2/2005	Weber et al.
6,151,516	A	11/2000	Kiani-Azarbayjany et al.	6,850,788	B2	2/2005	Al-Ali
6,152,754	A	11/2000	Gerhardt et al.	6,852,083	B2	2/2005	Caro et al.
6,157,850	A	12/2000	Diab et al.	6,861,639	B2	3/2005	Al-Ali
6,165,005	A	12/2000	Mills et al.	6,898,452	B2	5/2005	Al-Ali et al.
6,165,151	A	* 12/2000	Weiner 604/66	6,920,345	B2	7/2005	Al-Ali et al.
6,184,521	B1	2/2001	Coffin, IV et al.	6,931,268	B1	8/2005	Kiani-Azarbayjany et al.
6,206,830	B1	3/2001	Diab et al.	6,934,570	B2	8/2005	Kiani et al.
6,229,856	B1	5/2001	Diab et al.	6,939,305	B2	9/2005	Flaherty et al.
6,232,609	B1	5/2001	Snyder et al.	6,943,348	B1	9/2005	Coffin, IV
6,236,872	B1	5/2001	Diab et al.	6,950,687	B2	9/2005	Al-Ali
6,241,683	B1	6/2001	Macklem et al.	6,961,598	B2	11/2005	Diab
6,256,523	B1	7/2001	Diab et al.	6,970,792	B1	11/2005	Diab
6,263,222	B1	7/2001	Diab et al.	6,979,812	B2	12/2005	Al-Ali
6,278,522	B1	8/2001	Lepper, Jr. et al.	6,985,764	B2	1/2006	Mason et al.
6,280,213	B1	8/2001	Tobler et al.	6,993,371	B2	1/2006	Kiani et al.
6,285,896	B1	9/2001	Tobler et al.	6,996,427	B2	2/2006	Ali et al.
6,321,100	B1	11/2001	Parker	6,999,904	B2	2/2006	Weber et al.
6,334,065	B1	12/2001	Al-Ali et al.	7,003,338	B2	2/2006	Weber et al.
6,343,224	B1	1/2002	Parker	7,003,339	B2	2/2006	Diab et al.
6,349,228	B1	2/2002	Kiani et al.	7,015,451	B2	3/2006	Dalke et al.
6,360,114	B1	3/2002	Diab et al.	7,024,233	B2	4/2006	Ali et al.
6,368,283	B1	4/2002	Xu et al.	7,027,849	B2	4/2006	Al-Ali
6,371,921	B1	4/2002	Caro et al.	7,030,749	B2	4/2006	Al-Ali
6,377,829	B1	4/2002	Al-Ali	7,039,449	B2	5/2006	Al-Ali
6,388,240	B2	5/2002	Schulz et al.	7,041,060	B2	5/2006	Flaherty et al.
6,397,091	B2	5/2002	Diab et al.	7,044,918	B2	5/2006	Diab
6,430,525	B1	8/2002	Weber et al.	7,067,893	B2	6/2006	Mills et al.
6,463,311	B1	10/2002	Diab	7,096,052	B2	8/2006	Mason et al.
6,470,199	B1	10/2002	Kopotic et al.	7,096,054	B2	8/2006	Abdul-Hafiz et al.
6,501,975	B2	12/2002	Diab et al.	7,132,641	B2	11/2006	Schulz et al.
6,505,059	B1	1/2003	Kollias et al.	7,142,901	B2	11/2006	Kiani et al.
6,515,273	B2	2/2003	Al-Ali	7,149,561	B2	12/2006	Diab
6,519,487	B1	2/2003	Parker	7,186,966	B2	3/2007	Al-Ali
6,525,386	B1	2/2003	Mills et al.	7,190,261	B2	3/2007	Al-Ali
6,526,300	B1	2/2003	Kiani et al.	7,215,984	B2	5/2007	Diab
6,541,756	B2	4/2003	Schulz et al.	7,215,986	B2	5/2007	Diab
6,542,764	B1	4/2003	Al-Ali et al.	7,221,971	B2	5/2007	Diab
6,580,086	B1	6/2003	Schulz et al.	7,225,006	B2	5/2007	Al-Ali et al.
6,584,336	B1	6/2003	Ali et al.	7,225,007	B2	5/2007	Al-Ali
6,595,316	B2	7/2003	Cybulski et al.	RE39,672	E	6/2007	Shehada et al.
6,597,932	B2	7/2003	Tian et al.	7,239,905	B2	7/2007	Kiani-Azarbayjany et al.
6,597,933	B2	7/2003	Kiani et al.	7,245,953	B1	7/2007	Parker
6,606,511	B1	8/2003	Ali et al.	7,254,431	B2	8/2007	Al-Ali
6,632,181	B2	10/2003	Flaherty et al.	7,254,433	B2	8/2007	Diab et al.
				7,254,434	B2	8/2007	Schulz et al.

US 8,048,040 B2

Page 3

7,272,425 B2	9/2007	Al-Ali	7,355,512 B1	4/2008	Al-Ali	
7,274,955 B2	9/2007	Kiani et al.	7,371,981 B2	5/2008	Abdul-Hafiz	
D554,263 S	10/2007	Al-Ali	7,373,193 B2	5/2008	Al-Ali et al.	
7,280,858 B2	10/2007	Al-Ali et al.	7,373,194 B2	5/2008	Weber et al.	
7,289,835 B2	10/2007	Mansfield et al.	7,376,453 B1	5/2008	Diab et al.	
7,292,883 B2	11/2007	De Felice et al.	7,377,794 B2	5/2008	Al Ali et al.	
7,295,866 B2	11/2007	Al-Ali	7,377,899 B2	5/2008	Weber et al.	
7,328,053 B1	2/2008	Diab et al.	7,383,070 B2	6/2008	Diab et al.	
7,332,784 B2	2/2008	Mills et al.	7,415,297 B2	8/2008	Al-Ali et al.	
7,340,287 B2	3/2008	Mason et al.	2005/0010166 A1 *	1/2005	Hickle	604/66
7,341,559 B2	3/2008	Schulz et al.	2005/0177096 A1 *	8/2005	Bollish et al.	604/65
7,343,186 B2	3/2008	Lamego et al.				
D566,282 S	4/2008	Al-Ali et al.				

* cited by examiner

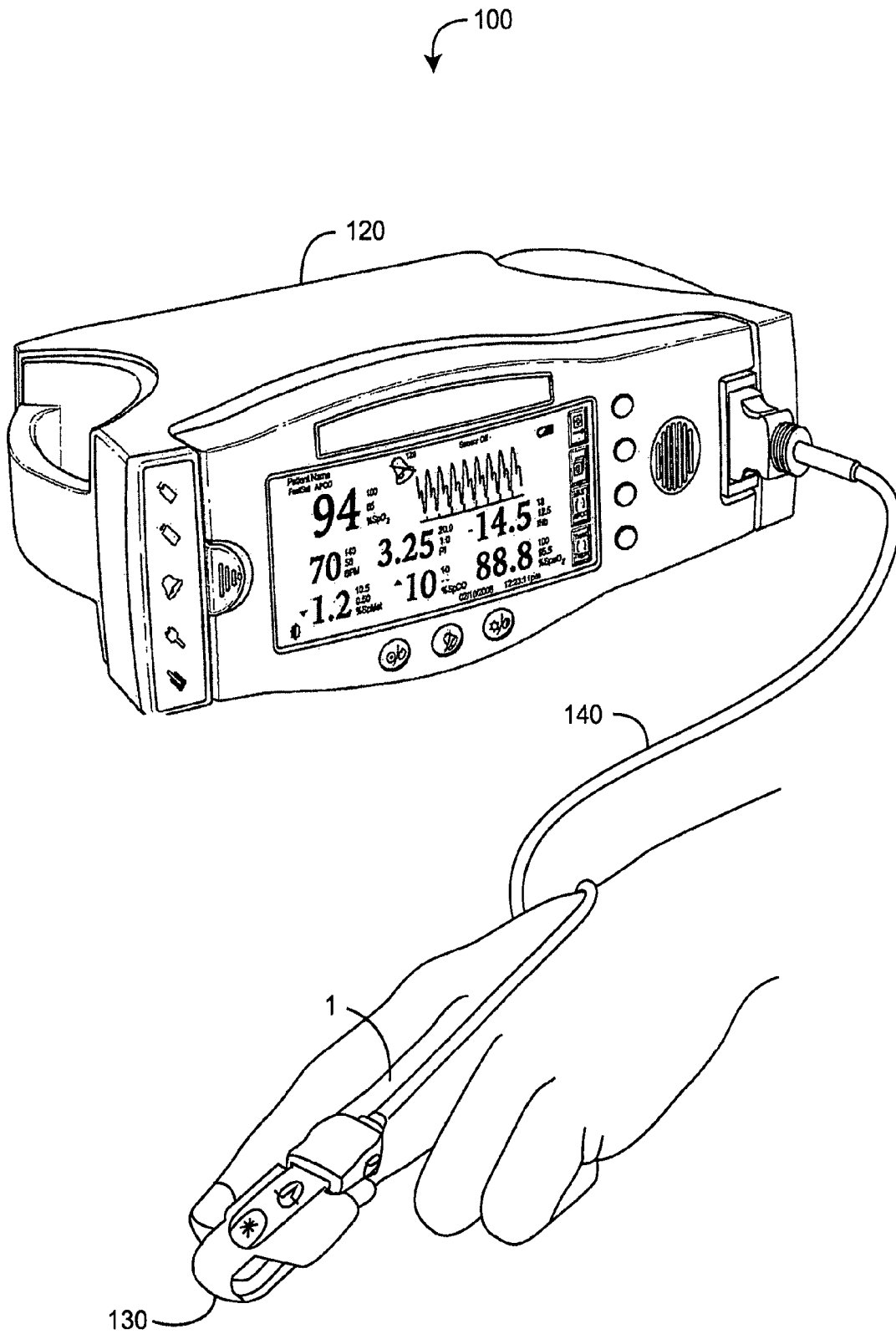

FIG. 1 (Prior Art)

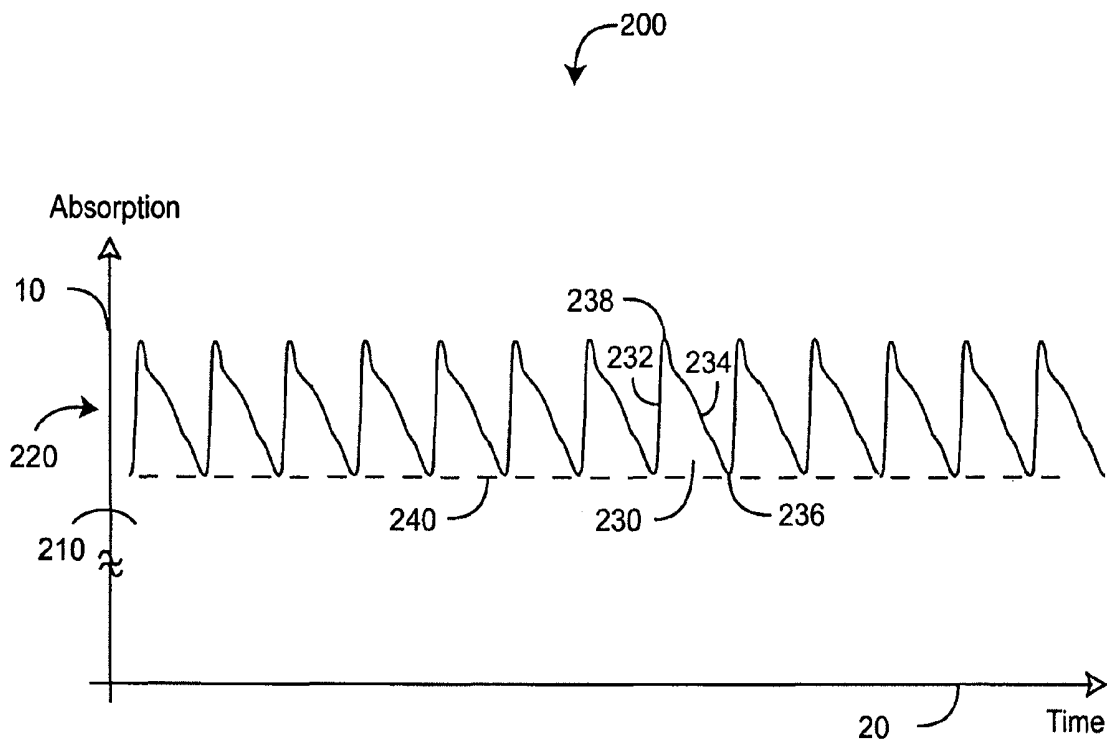

FIG. 2 (Prior Art)

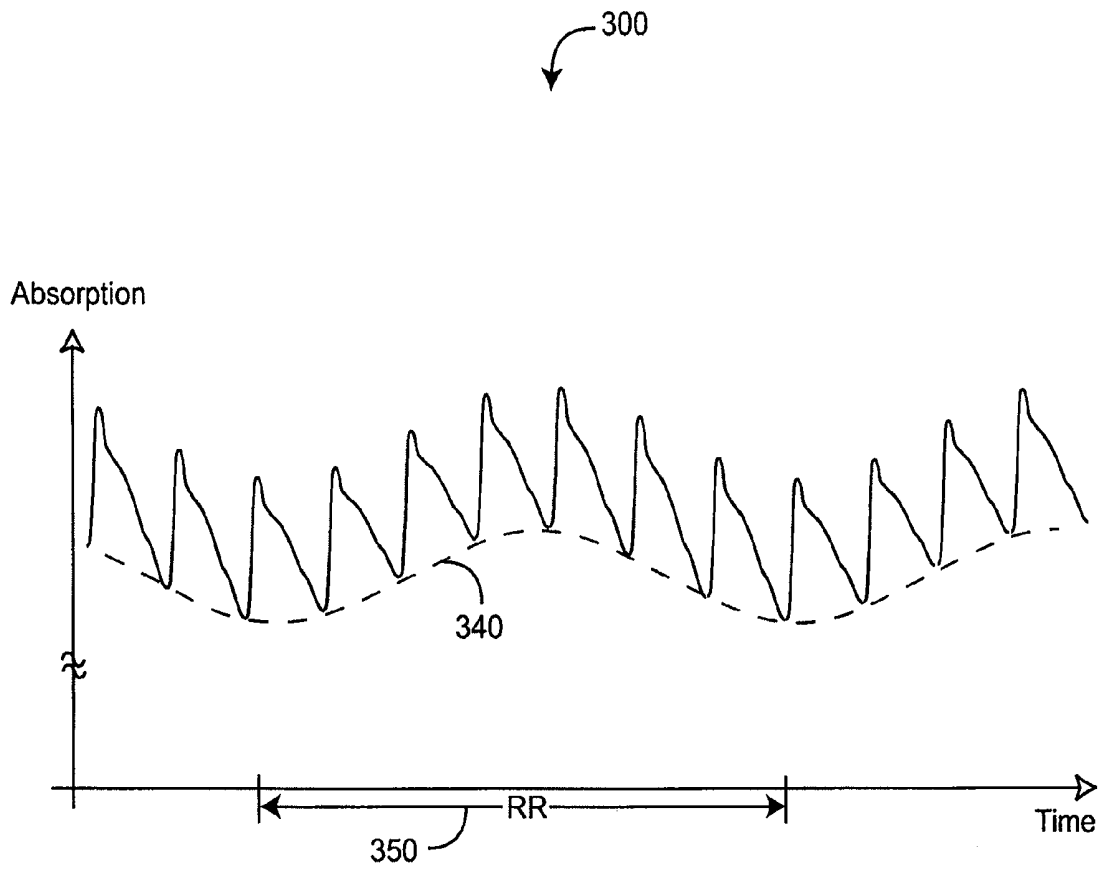

FIG. 3

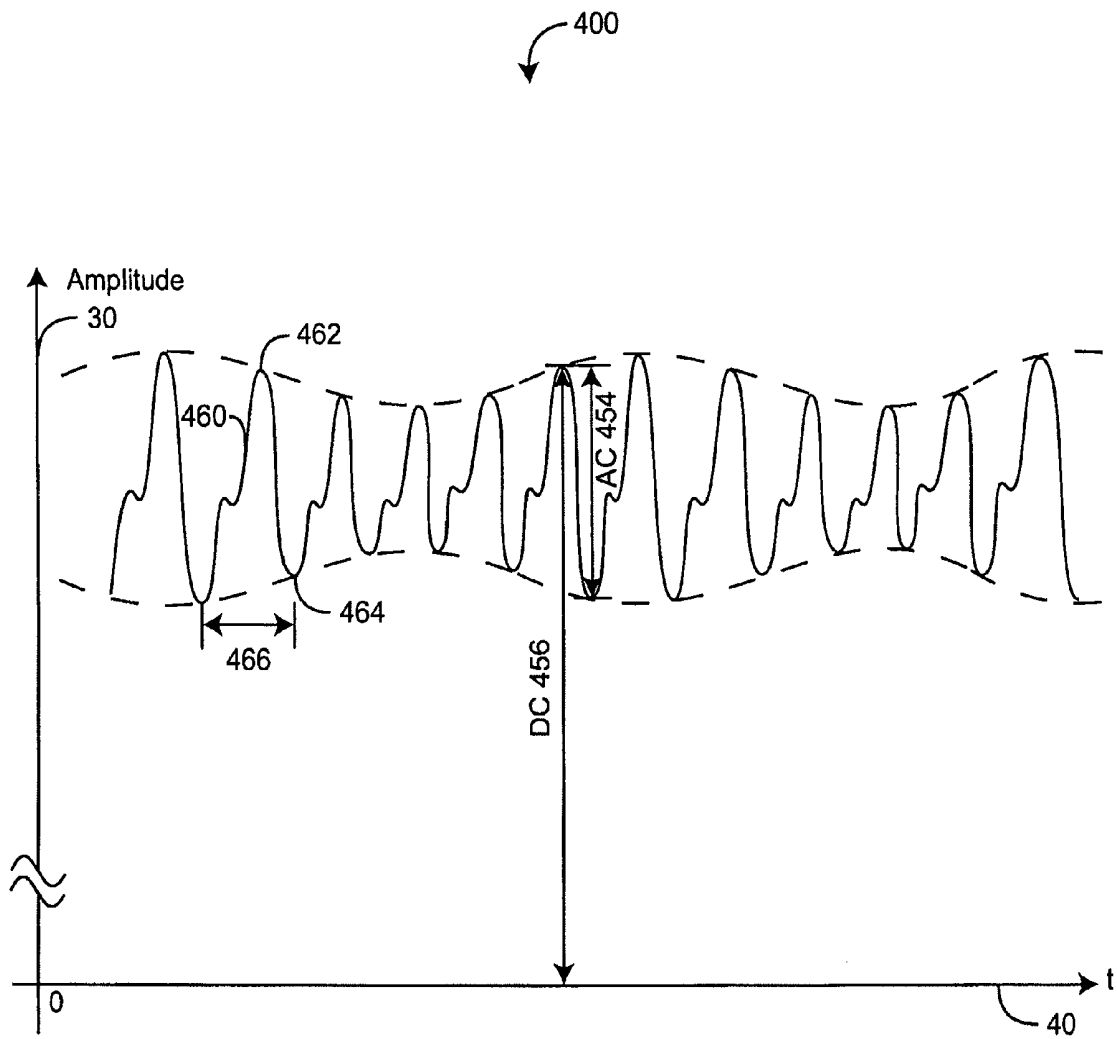

FIG. 4

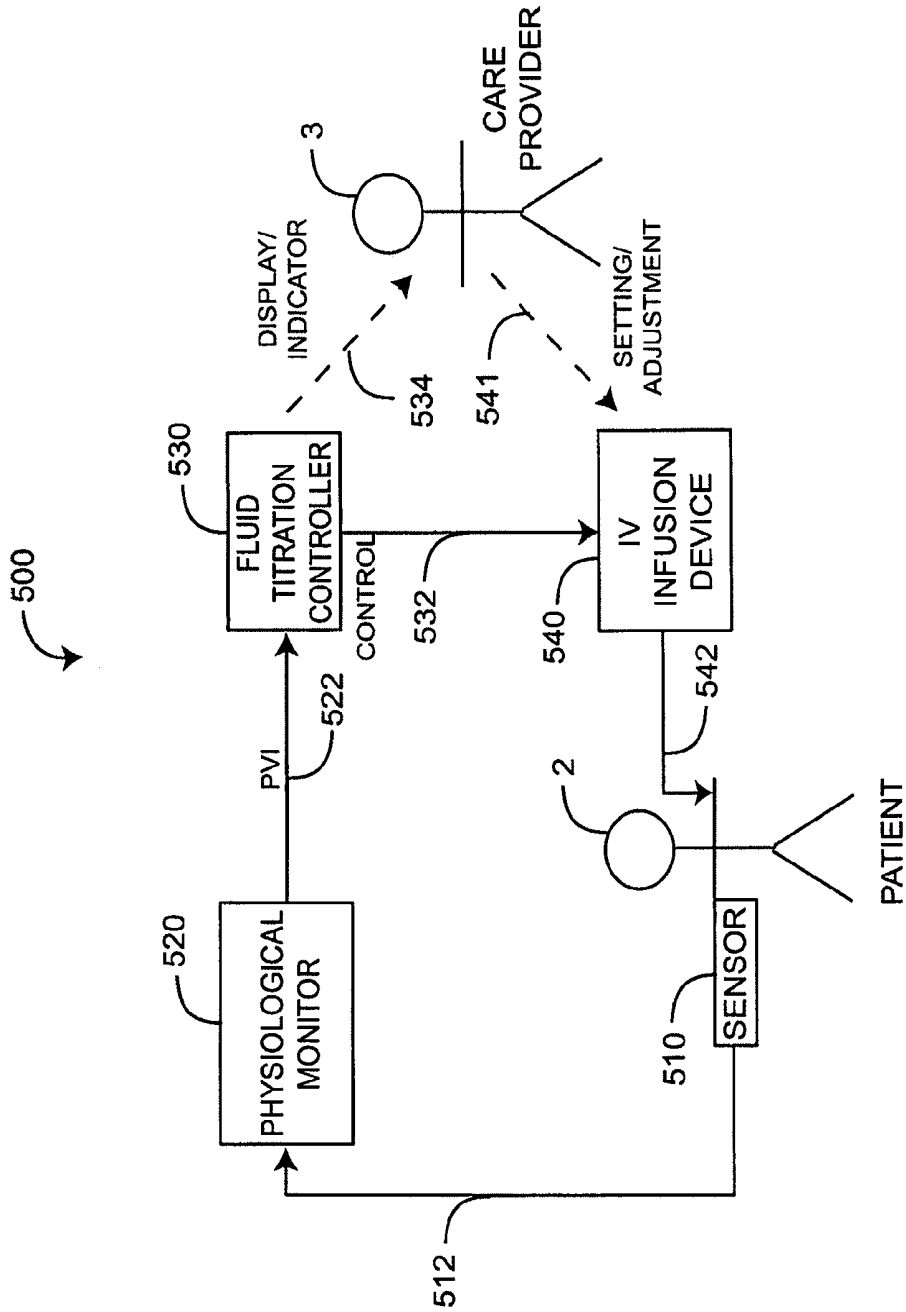

FIG. 5

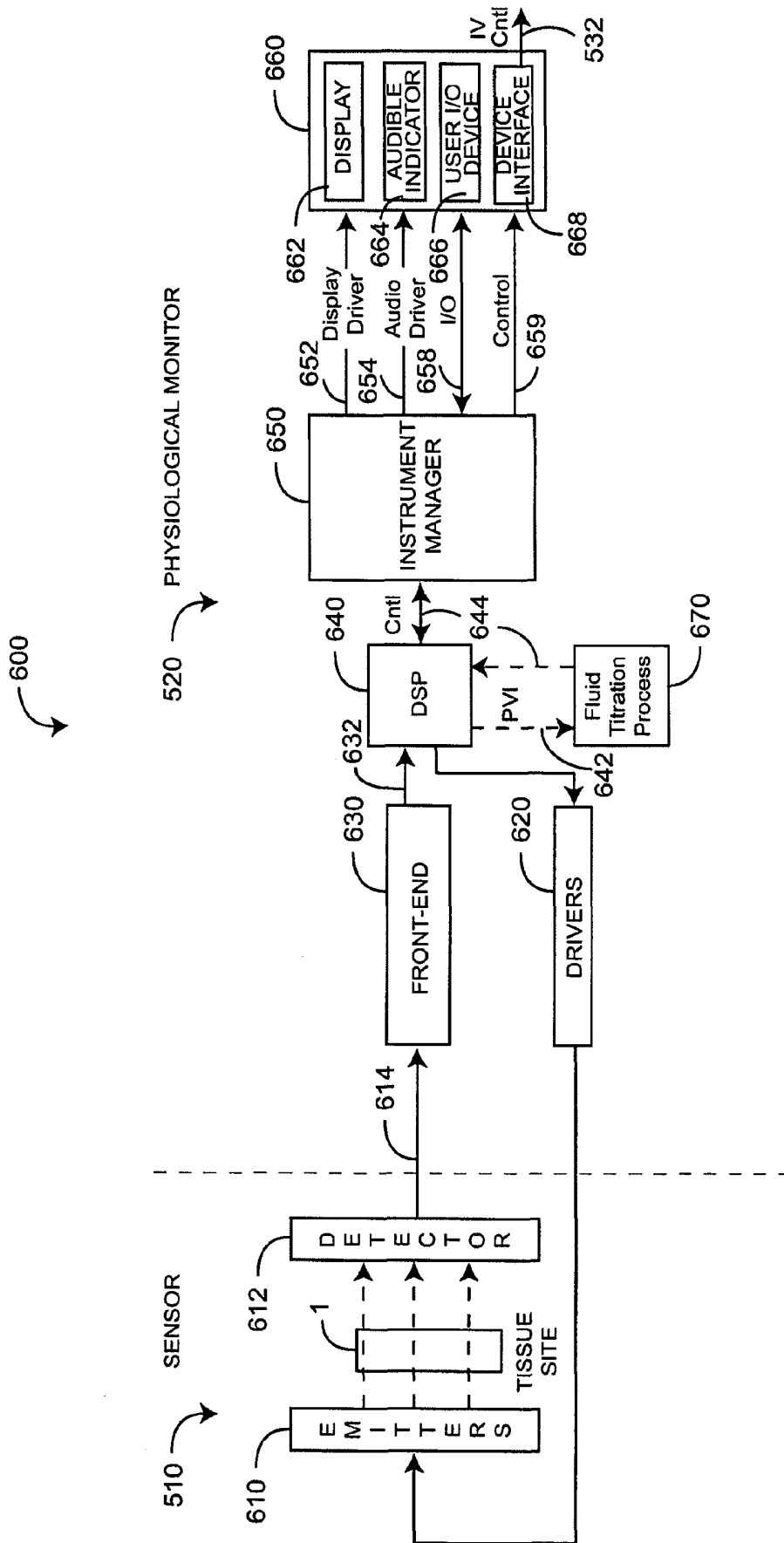

FIG. 6

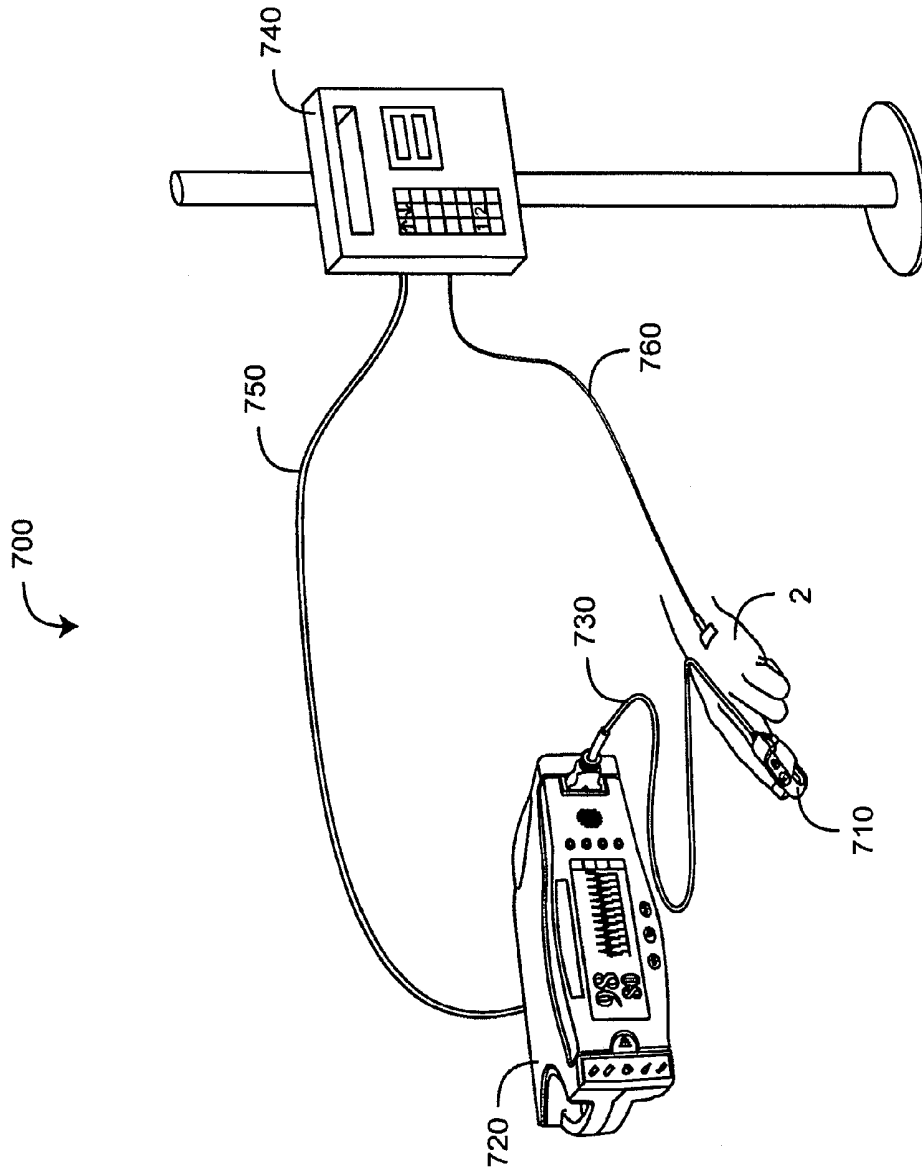

FIG. 7

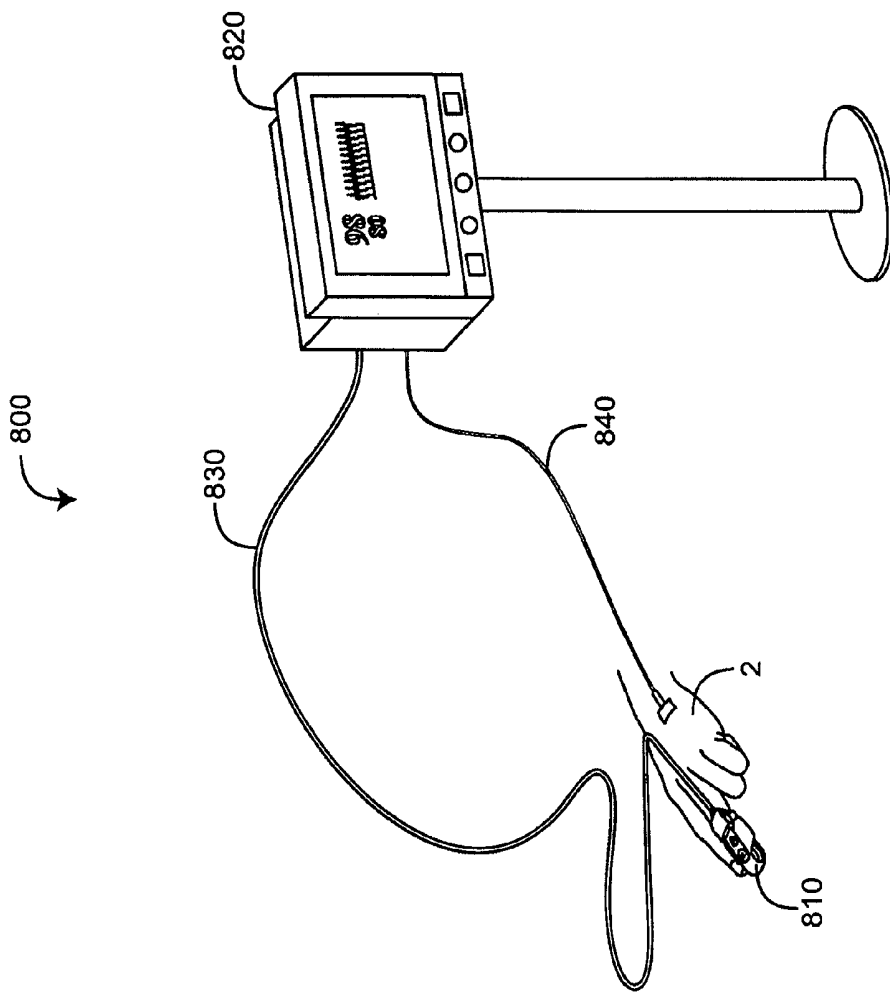

FIG. 8

FLUID TITRATION SYSTEM

REFERENCE TO RELATED APPLICATION

The present application claims priority benefit under 35 U.S.C. §119(e) from U.S. Provisional Application No. 60/993,584, filed Sep. 13, 2007, entitled "Fluid Titration System," which is incorporated herein by reference.

BACKGROUND OF THE INVENTION

FIG. 1 illustrates a physiological monitoring system 100 having a physiological monitor 120, a noninvasive sensor 130 attached to a tissue site 1, and a sensor cable 140 interconnecting the monitor 120 and the sensor 130. Physiological monitoring systems for measuring constituents of circulating blood have gained rapid acceptance in a wide variety of medical applications, including surgical wards, intensive care and neonatal units, general wards, home care, physical training, and virtually all types of monitoring scenarios. The non-invasive sensor 130 has light emitting diodes (LEDs) and a detector. The LEDs transmit optical radiation into the tissue site 1, and the detector responds to the intensity of the optical radiation after absorption by pulsatile blood flow within the tissue site. Based upon this response, the physiological monitor 120 determines measurements for physiological parameters. The physiological monitoring system 100 may incorporate pulse oximetry, which is a widely accepted noninvasive procedure for measuring physiological parameters, such as oxygen saturation and pulse rate among others. The physiological monitoring system 100 may also incorporate advanced features, such as a multiple wavelength sensor and advanced processes for determining other physiological parameters, such as carboxyhemoglobin, methemoglobin and total hemoglobin, as a few examples. The physiological monitor 120 displays the physiological parameters and typically provides visual and audible alarm mechanisms that alert a caregiver when these parameters are outside of predetermined limits.

Pulse oximeters capable of reading through motion induced noise are disclosed in at least U.S. Pat. Nos. 6,770,028, 6,658,276, 6,650,917, 6,157,850, 6,002,952, 5,769,785, and 5,758,644; low noise pulse oximetry sensors are disclosed in at least U.S. Pat. Nos. 6,088,607 and 5,782,757; all of which are assigned to Masimo Corporation, Irvine, Calif. ("Masimo") and are incorporated by reference herein.

Physiological monitors and corresponding multiple wavelength optical sensors are described in at least U.S. patent application Ser. No. 11/367,013, filed Mar. 1, 2006 and entitled Multiple Wavelength Sensor Emitters and U.S. patent application Ser. No. 11/366,208, filed Mar. 1, 2006 and entitled Noninvasive Multi-Parameter Patient Monitor, both assigned to Masimo Laboratories, Irvine, Calif. (Masimo Labs) and both incorporated by reference herein.

Further, physiological monitoring systems that include low noise optical sensors and pulse oximetry monitors, such as any of LNOP® adhesive or reusable sensors, SofTouch™ sensors, Hi-Fi Trauma™ or Blue™ sensors; and any of Radical®, SatShare™, Rad-9™, Rad-5™, Rad-5v™ or PPO+™ Masimo SET® pulse oximeters, are all available from Masimo. Physiological monitoring systems including multiple wavelength sensors and corresponding noninvasive blood parameter monitors, such as Rainbow™ adhesive and reusable sensors and RAD-57™ and Radical-7™ monitors for measuring SpO₂, pulse rate, perfusion index, signal quality, HbCO and HbMet among other parameters are also available from Masimo.

FIG. 2 illustrates the standard plethysmograph waveform 200, which can be derived from a pulse oximetry system, as described above. The plethysmograph waveform 200 illustrates light absorption at the tissue site, shown along the y-axis 10, versus time, shown along the x-axis 20. The total absorption includes components of static absorption 210 and variable absorption 220. Static absorption 210 is due to tissue, venous blood and a base volume of arterial blood. Variable absorption 220 is due to the pulse-added volume of arterial blood. That is, the plethysmograph waveform 200 is a visualization of the tissue site arterial blood volume change over time, and is a function of heart stroke volume, pressure gradient, arterial elasticity and peripheral resistance. The ideal waveform pulse 230 displays a broad peripheral flow curve, with a short, steep inflow phase 232 followed by a 3 to 4 times longer outflow phase 234. The inflow phase 232 is the result of tissue distention by the rapid blood volume inflow during ventricular systole. During the outflow phase 234, blood flow continues into the vascular bed during diastole. The plethysmograph baseline 240 indicates the minimum basal tissue perfusion.

SUMMARY OF THE INVENTION

FIG. 3 illustrates a hypovolemic plethysmograph waveform 300, i.e. a plethysmograph displaying characteristics of a person having an abnormal decrease in blood volume. Hypovolemia is often caused from blood loss during surgery or due to an injury. Under hypovolemic conditions, a respiration-induced cyclical variation occurs in a plethysmograph baseline 340. In particular, the baseline 340 varies with a period corresponding to the respiration rate 350. This cyclical variation is particularly evident in patients undergoing positive ventilation. The amount of cyclical variation correlates to a person's blood volume, i.e. the less blood volume the greater the cyclical variation in the plethysmograph waveform. Accordingly, a measure of plethysmograph variation may be indicative of hypovolemic conditions.

FIG. 4 illustrates a plethysmograph 400 plotted on an amplitude axis 30 versus a time axis 40. As described above, the amplitude may be responsive to light absorption of pulsatile blood flow with a person's tissue. The plethysmograph 400 has multiple pulses 460 each with a peak 462 and a valley 464 and extending over a time period 466. A perfusion index (PI) value can be defined for each pulse 460:

$$PI = AC/DC \quad (1)$$

where "AC" 454 designates a peak amplitude 462 minus a valley amplitude 464 for a particular pulse and where "DC" 456 designates a peak amplitude 462 for a particular pulse. In an embodiment, an IR channel plethysmograph from a detector response to an IR wavelength LED is utilized to calculate PI. A plethysmograph variability index (PVI) is then calculated that is responsive to variations in perfusion index, as described below.

In an embodiment, PVI calculations utilize only PI values resulting from acceptable plethysmograph pulses. For example, a red channel plethysmograph responsive to a red wavelength LED is used to verify acceptable pulses in the IR channel. Physiological plethysmograph identification is disclosed in U.S. Pat. No. 7,044,918 titled Plethysmograph Pulse Recognition Processor, which is incorporated by reference herein. PVI values are calculated from a sorted and trimmed buffer representing a sliding time window of PI values. The sort orders the PI values from the minimum PI at one end of the buffer to the maximum PI at the other end of the

buffer. A predetermined number of both maximum and minimum PIs are deleted from each end of the buffer and PVI is calculated as:

$$PVI = \frac{(PI_{MAX} - PI_{MIN})}{PI_{MAX}} \times 100 \quad (2)$$

That is, PVI is the PI variation, expressed as a percentage of the difference between the maximum and minimum PIs remaining in the buffer. In an embodiment, a median PVI is calculated from PVIs stored in a second buffer. PVI is described in U.S. Provisional Patent App. No. 60/873,663 filed Dec. 9, 2006 titled Plethysmograph Variability Index, incorporated by reference herein. A PVI enabled physiological monitor advantageously provides a noninvasive numerical measure of hypovolemic conditions so as to titrate patient fluids.

BRIEF DESCRIPTION OF THE DRAWINGS

FIG. 1 is an illustration of a physiological monitoring system;

FIG. 2 is an absorption versus time graph of a standard pulse oximeter plethysmograph;

FIG. 3 is an absorption versus time graph of a plethysmograph exhibiting a respiration-induced, baseline cyclical variation;

FIG. 4 is a plethysmograph illustrating measurement of a plethysmograph variability index (PVI);

FIG. 5 is a general block diagram of an intravenous fluid titration system;

FIG. 6 is a general block diagram of a physiological monitoring system configured for a fluid titration application; and

FIGS. 7-8 are illustrations of intravenous fluid titration system embodiments.

DETAILED DESCRIPTION OF THE PREFERRED EMBODIMENT

FIG. 5 illustrates a fluid titration system 500 having a sensor 510 attached to a person 2, a physiological monitor 520, a fluid titration controller 530 and an intravenous (IV) infusion device 540. Advantageously, the fluid titration system 500 utilizes a perfusion variability parameter, such as PVI described above, to regulate the administration of fluids to a person so as to control or prevent low blood volume or a hypovolemia. A noninvasive, optical sensor 510 allows a measure of tissue blood perfusion by detecting the absorption of sensor transmitted light by pulsatile blood flow within a tissue site, such as a finger, foot or ear to name a few. A sensor signal 512 responsive to that absorption is received and processed by the physiological monitor 520, which derives a plethysmograph variability index (PVI) or other measure of plethysmograph variability or, similarly, blood perfusion variability. A fluid titration controller 530 is responsive to PVI 522 and in particular to relatively large values of PVI indicating relatively large variations in perfusion index, a potential indicator of hypovolemia. The fluid titration controller 530, in turn, provides a control output 532 to an intravenous (IV) infusion device 540 so as to regulate circulating fluids and alleviate a hypovolemic condition in the person 2. The IV infusion device 540 administers a liquid solution, such as blood products or nutrient fluids injected directly into a vein (usually in the arm) at a prescribed rate over a period of time. In a closed-loop embodiment, the fluid titration controller 530 is responsive to PVI 522 or similar measure so as to start, control the rate of, or stop the infusion of fluids into the person 2. In an open-loop embodiment, the fluid titration controller 530 presents a display or other indicator 534 to a care provider

3 who manually inputs an adjustment or other setting 541 into the infusion device 540 so as to start, control the rate of, or stop the infusion of fluids into the person 2.

As shown in FIG. 5, the fluid titration controller 530 may be implemented in the physiological monitor 520, implemented in the IV infusion device 540, distributed between the physiological monitor 520 and the IV infusion device 540, or implemented as a standalone processing device. In an embodiment, the fluid titration controller 530 is a firmware process executed within the physiological monitor 520, as described with respect to FIG. 6, below. Physically, the physiological monitor 520 and the IV infusion device 540 may be separate units, as described with respect to FIG. 7, below, or combined into a single unit, as described with respect to FIG. 8, below.

In an embodiment, the fluid titration process 670 triggers a control output 644 so as to enable fluid flow from the IV infusion device 540 if PVI increases above a predetermined threshold or otherwise reflects that hypovolemia may no longer be indicated for a patient 2 (FIG. 5). In an embodiment, the fluid titration process 670 modifies a control output 644 so as to adjust the rate of fluid flow or total administered amount of fluid flow from the IV infusion device 540 according to changes in PVI that reflect that hypovolemia may be decreasing or increasing in severity.

FIG. 7 illustrates a fluid titration system embodiment 700 having an optical sensor 710 attached to a person 2; a physiological monitor 720; a sensor cable 730 interconnecting the sensor 710 and monitor 720; an IV infusion device 740; a control cable 750 interconnecting the monitor 720 and infusion device 740; and an IV tube 760 also attached to the person 2. The optical sensor 710 provides a sensor signal via a sensor cable 730 to the physiological monitor 720. The physiological monitor 720 generates blood parameter measurements and processes those parameters to generate monitor and control outputs, as described with respect to FIGS. 5-6, above. In particular, the physiological monitor 720 generates control signals via a control cable 750 to the IV infusion device 740, which provides fluids to the person 2 via the IV tube 760.

FIG. 8 illustrates another fluid titration system embodiment 800 having an optical sensor 810 and an IV tube 840 attached to a person 2 at one end and an integrated physiological monitor 820 at another end. The integrated physiological monitor 820 incorporates the functions of a physiological monitor 520 (FIG. 6) and an IV infusion device within a single unit or within physically connected units.

A fluid titration system has been disclosed in detail in connection with various embodiments. These embodiments are disclosed by way of examples only and are not to limit the scope of the claims that follow. One of ordinary skill in art will appreciate many variations and modifications.

What is claimed is:

1. A fluid titration system comprising:
 - an optical sensor that transmits multiple wavelengths of optical radiation into a tissue site of a person and detects the optical radiation after attenuation by pulsatile blood flowing within the tissue site so as to generate a sensor signal responsive to the detected optical radiation;
 - a physiological monitor in electrical communications with the optical sensor, the physiological monitor configured to calculate a measure of plethysmograph variability (PV) from the sensor signal; and
 - an infusion device that administers a liquid solution via an intravenous (IV) connection to the person in response to the measure of PV.

5

2. The fluid titration system according to claim 1 further comprising a fluid titration controller, the fluid titration controller comprising:

- a PV measure input;
- a fluid control output; and
- a predetermine relationship between the PV measure input and the fluid control output,

wherein the control output is in communication with the infusion device so as to regulate at least one of fluid flow start, rate and stop.

3. The fluid titration system according to claim 2 wherein the PV measure is responsive to changes in perfusion index (PI) over a time interval where one or more complete respiratory cycles have occurred.

4. The fluid titration system according to claim 3 further comprising:

- a digital signal processor (DSP); and
- a closed-loop fluid titration algorithm implemented in firmware executing on the DSP so as to implement the predetermined relationship.

5. The fluid titration system according to claim 4 further comprising an enclosure integrating the physiological monitor with the infusion device.

6. A fluid titration method comprising:

- deriving a plethysmograph waveform from an optical sensor attached to a person;
- determining a measure of perfusion variability corresponding to the plethysmograph waveform; and
- adjusting blood volume for the person based upon the perfusion variability metric.

7. The fluid titration method according to claim 6 wherein determining a measure of perfusion variability comprises calculating a perfusion variability index based upon a maximum perfusion measurement compared to a minimum perfusion measurement.

8. The fluid titration method according to claim 7 wherein adjusting comprises displaying an IV infusion device adjustment prompt to a care provider according to the perfusion variability index.

9. The fluid titration method according to claim 7 wherein adjusting comprises transmitting a control signal to an IV infusion device according to the perfusion variability index.

10. The fluid titration method according to claim 9 wherein the transmitting comprises at least one of:

- disabling the IV infusion device from infusing fluid when PVI is less than a first predetermined threshold; and
- enabling the IV infusion device for infusing fluid when PVI is greater than a second predetermined threshold.

11. A fluid titration system comprising:

- a sensor means for transmitting multiple wavelengths of optical radiation into a tissue site and detecting the optical radiation after attenuation by pulsatile blood flow within the tissue site;

a physiological monitor means in communications with the sensor means for deriving a plethysmograph and calculating a measure of plethysmograph variability;

6

an IV infusion device in communication with the fluid titration controller means configured to infuse a fluid into the person; and

a titration controller means for at least partially regulating the fluid infusion in response to the measure of plethysmograph variability.

12. The fluid titration system according to claim 11 wherein the titration controller means comprises an open loop means for utilizing a care provider to adjust the IV infusion device.

13. The fluid titration system according to claim 12 wherein the open loop means comprises an indicator means for communicating infusion adjustment to a care provider.

14. The fluid titration system according to claim 11 wherein the titration controller means comprises a closed-loop means for directly controlling fluid delivery by the IV infusion device.

15. The fluid titration system according to claim 14 wherein the closed-loop means comprises an infusion control output for transmitting a control signal to the IV infusion device.

16. A fluid titration method comprising:

- deriving a plethysmograph in response to an optical sensor attached to a person, the plethysmograph having a plurality of pulses in response to the person's arterial blood flow, the pulse minima of the plethysmograph defining a baseline;
- calculating a parameter indicative of a variability of the plethysmograph;
- infusing fluid into the person via an IV; and
- regulating the infusing according to the parameter.

17. The fluid titration method according to claim 16 wherein the calculating comprises:

- determining a plurality of perfusion measures corresponding to physiologically acceptable ones of the pulses; and
- computing a perfusion variation from the perfusion measures.

18. The intravenous fluid titration method according to claim 17 wherein the infusing comprises:

- connecting an IV infusion device to the IV; and
 - communicating an infusion control to the IV infusion device,
- wherein fluid flow from the IV infusion device is determined by the infusion control.

19. The intravenous fluid titration method according to claim 18 wherein the regulating comprises outputting a disabling signal on the infusion control when the variability parameter is below a predetermined threshold.

20. The intravenous fluid titration method according to claim 18 wherein the regulating comprises outputting an enabling signal on the infusion control when the parameter is above a predetermined threshold.

* * * * *

UNITED STATES PATENT AND TRADEMARK OFFICE
CERTIFICATE OF CORRECTION

PATENT NO. : 8,048,040 B2
APPLICATION NO. : 12/208998
DATED : November 1, 2011
INVENTOR(S) : Massi E. Kiani

Page 1 of 1

It is certified that error appears in the above-identified patent and that said Letters Patent is hereby corrected as shown below:

At column 6, line 52, in Claim 20, please delete “parameter” and insert therefore,
--variability parameter--.

Signed and Sealed this
Twenty-sixth Day of June, 2012

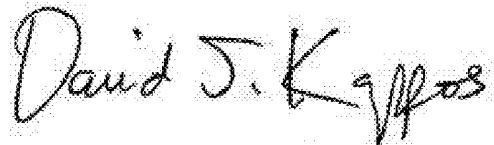
A handwritten signature in black ink that reads "David J. Kappos". The signature is written in a cursive style with a large initial "D".

David J. Kappos
Director of the United States Patent and Trademark Office

专利名称(译)	流体滴定系统		
公开(公告)号	US8048040	公开(公告)日	2011-11-01
申请号	US12/208998	申请日	2008-09-11
[标]申请(专利权)人(译)	梅西莫股份有限公司		
申请(专利权)人(译)	Masimo公司		
当前申请(专利权)人(译)	摩根大通银行, NATIONAL ASSOCIATION		
[标]发明人	KIANI MASSI E		
发明人	KIANI, MASSI E.		
IPC分类号	A61M5/00 A61B5/00		
CPC分类号	A61B5/14551 A61B5/6826 A61B5/6838 A61M5/142 A61M2205/3306 A61M2205/3313 A61B5/0295		
助理审查员(译)	ANDERSON, MICHAEL J		
优先权	60/993584 2007-09-13 US		
其他公开文献	US20090076462A1		
外部链接	Espacenet USPTO		

摘要(译)

流体滴定系统具有光学传感器，生理监测器，滴定控制器和输注装置。光学传感器将多个波长的光传输到人的组织部位，并在通过组织部位内流动的脉动血液衰减后检测光辐射。生理监测器接收所得到的传感器信号并导出对应于脉动血流的体积描记器。监测器还计算体积描记器变异性测量值，该测量值响应组织部位灌注的变化。滴定控制器根据可变量性测量产生流体控制输出。输注装置根据流体控制输出通过静脉内（IV）连接向人施用液体溶液，以便调节流体流动开始，速率和停止中的至少一个。

