



US 20070106169A1

(19) **United States**

(12) **Patent Application Publication**
Fadem

(10) **Pub. No.: US 2007/0106169 A1**

(43) **Pub. Date: May 10, 2007**

(54) **METHOD AND SYSTEM FOR AN
AUTOMATED E.E.G. SYSTEM FOR
AUDITORY EVOKED RESPONSES**

(76) Inventor: **Kalford C. Fadem, Louisville, KY
(US)**

Related U.S. Application Data

(60) Provisional application No. 60/479,684, filed on Jun. 19, 2003. Provisional application No. 60/557,230, filed on Mar. 29, 2004.

Publication Classification

(51) **Int. Cl.**
A61B 5/04 (2006.01)
A61B 5/00 (2006.01)
(52) **U.S. Cl.** **600/544; 600/559; 600/383**

Correspondence Address:
FROST BROWN TODD, LLC
2200 PNC CENTER
201 E. FIFTH STREET
CINCINNATI, OH 45202 (US)

(57) **ABSTRACT**

A dyslexia screening test system suitable for clinical use includes an integrated headset that efficiently and conveniently performs an auditory evoked response (AER) test by positioning electrodes about the ears of the subject. An integral control module automatically performs the test, providing simplified controls and indications to the clinician. A number of screening tests that are stored in the headset are periodically uploaded for billing, remote analysis and result reporting.

(21) Appl. No.: **10/561,572**

(22) PCT Filed: **Jun. 18, 2004**

(86) PCT No.: **PCT/US04/19418**

§ 371(c)(1),
(2), (4) Date: **Dec. 19, 2005**

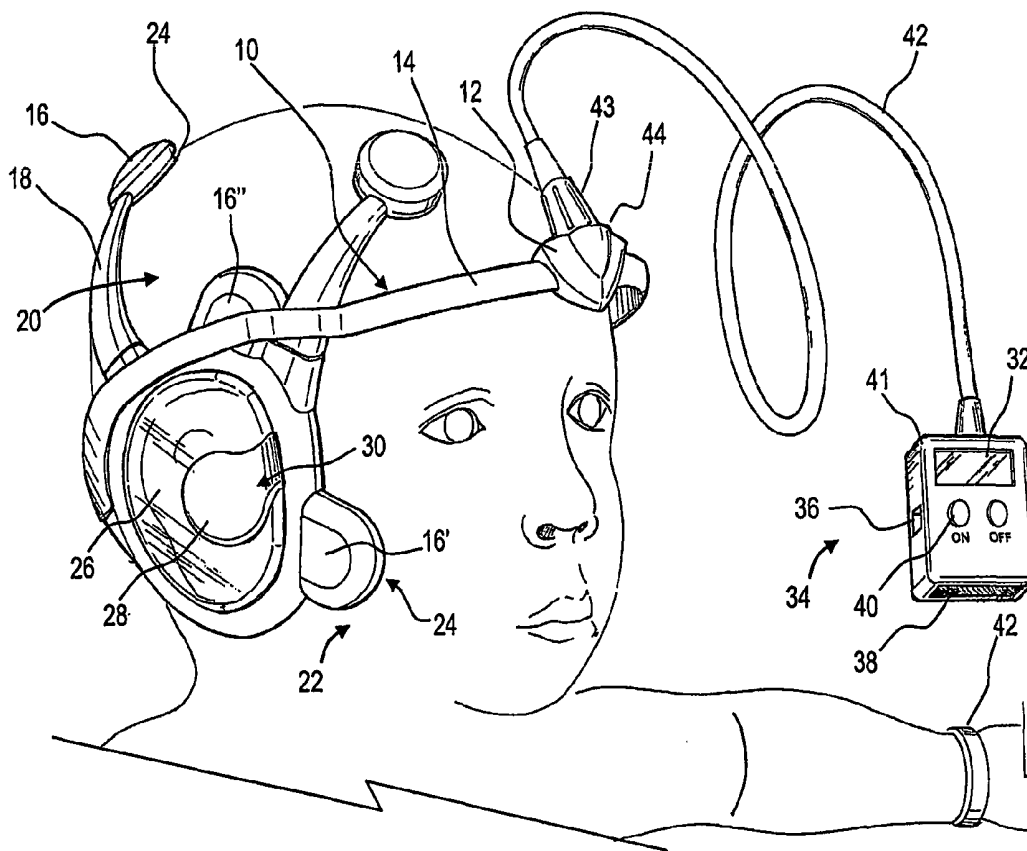

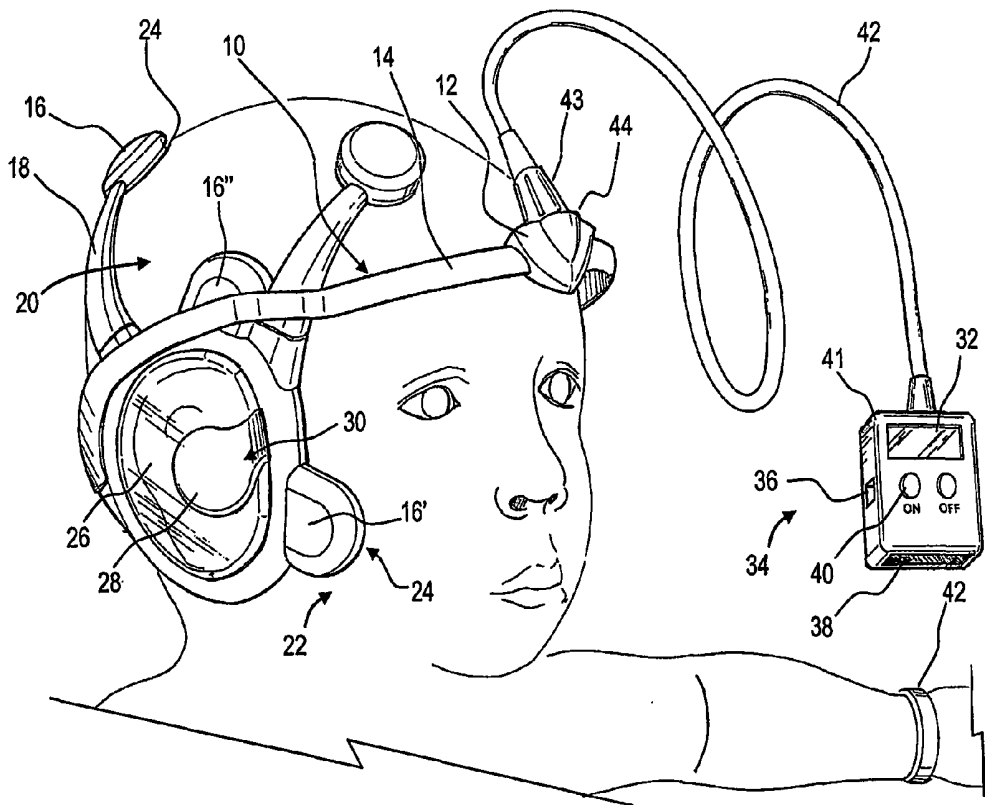

FIG. 1

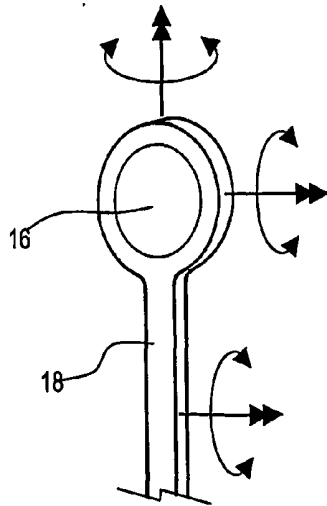

FIG. 2

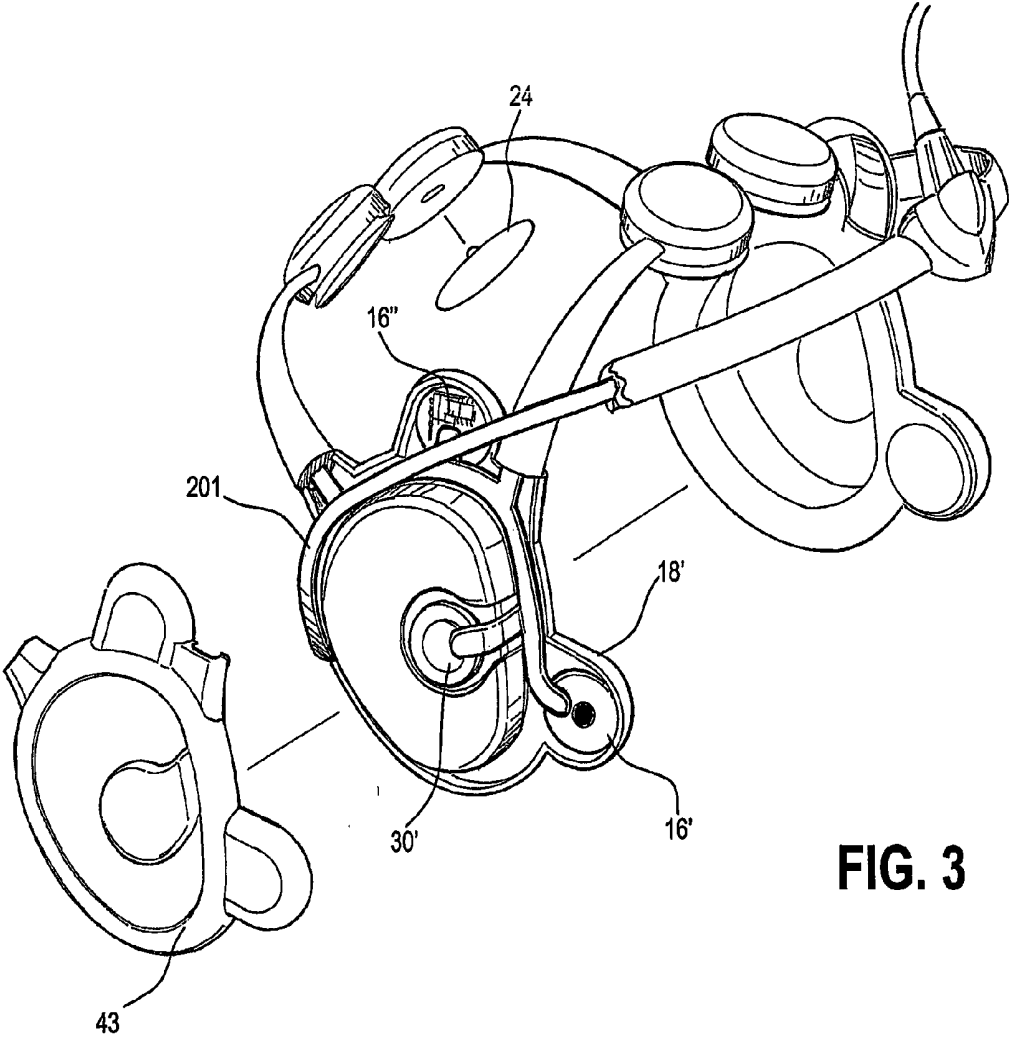

FIG. 3

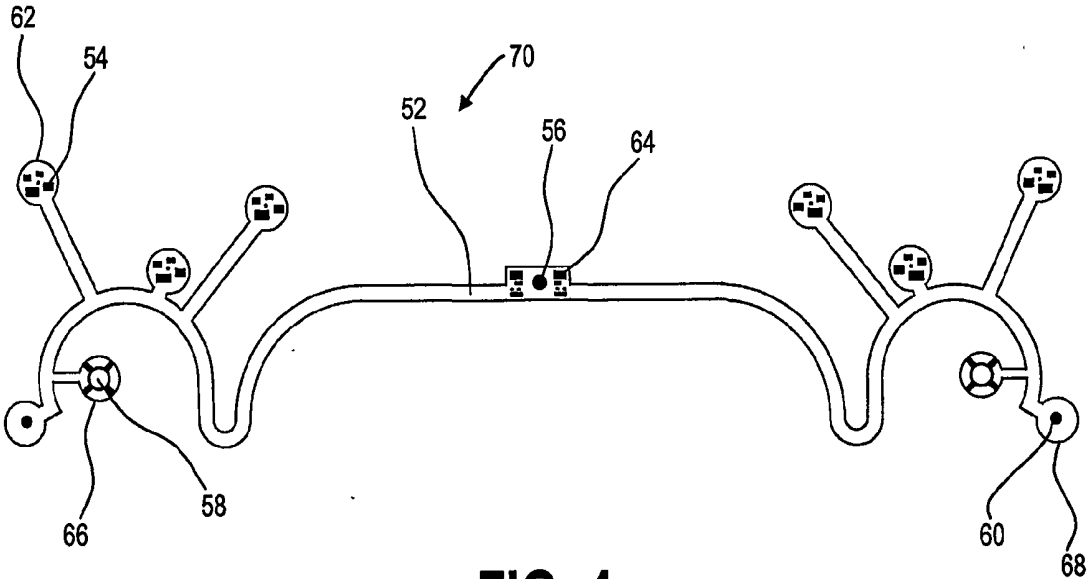

FIG. 4

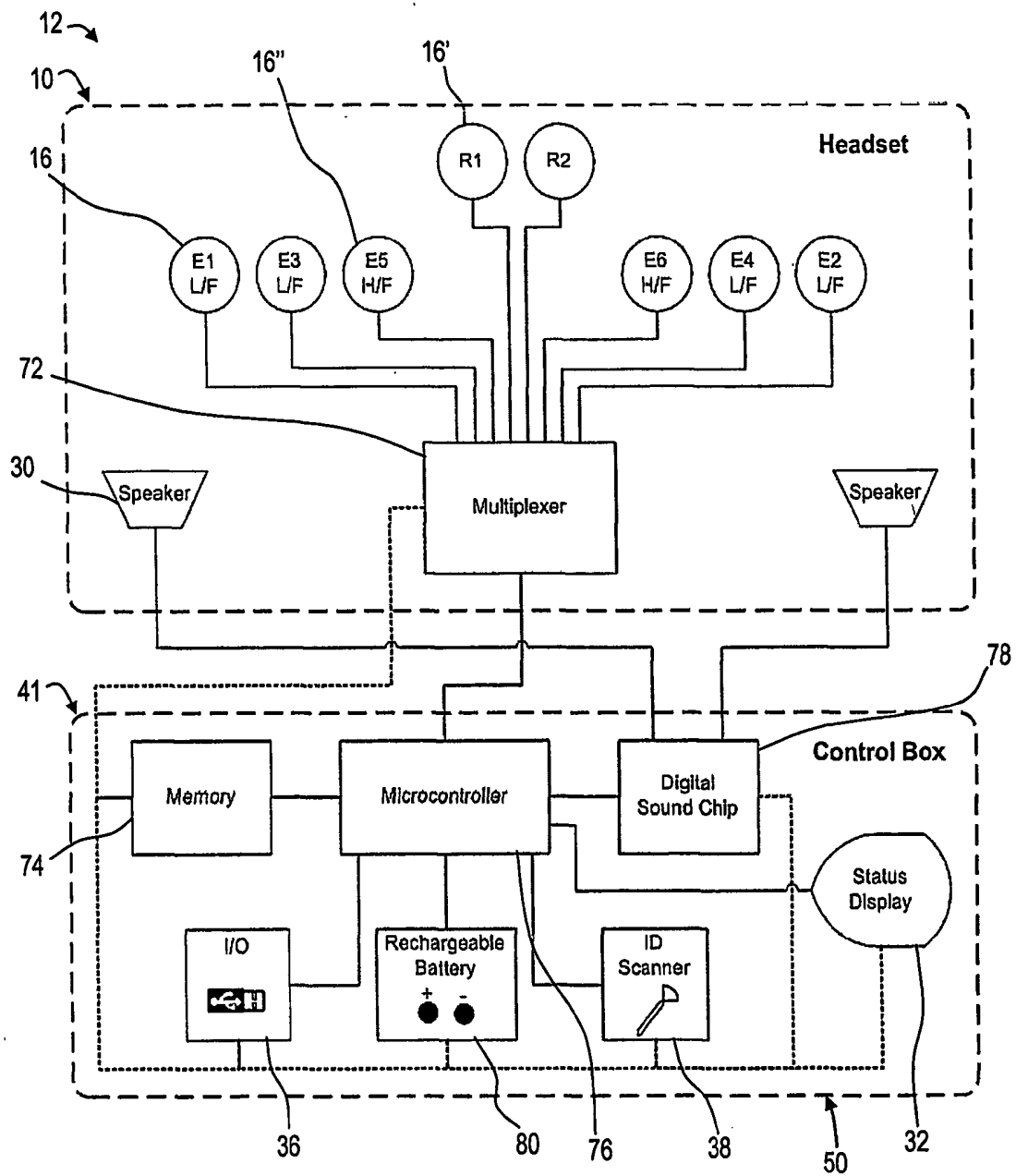

FIG. 5

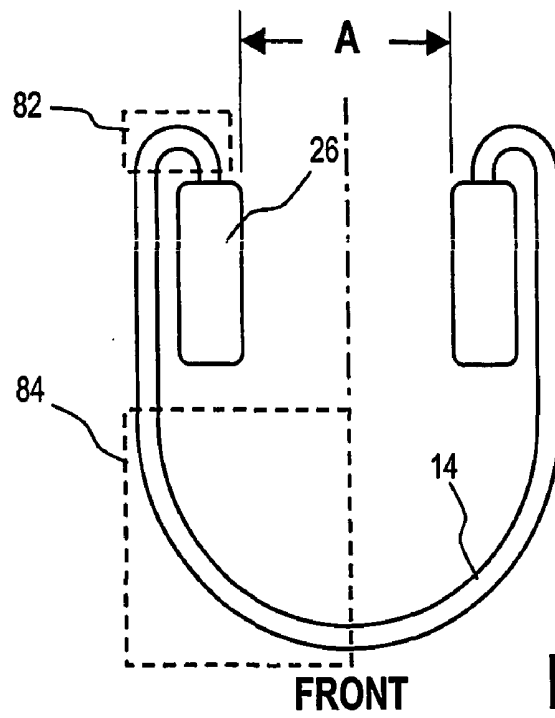

FIG. 6B

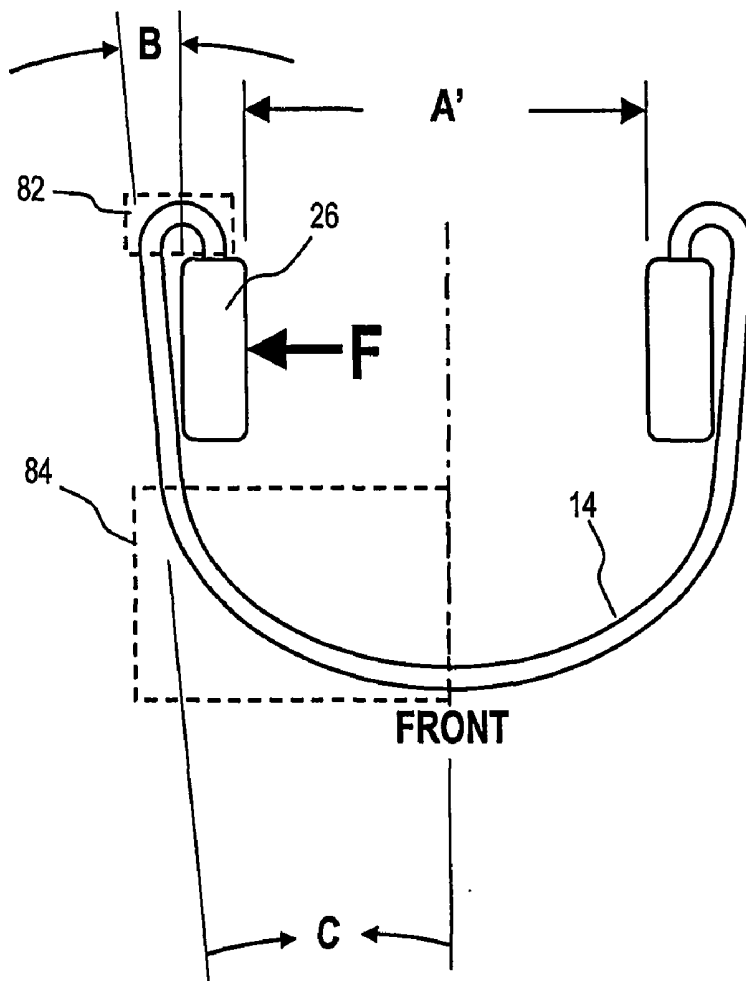

FIG. 6B

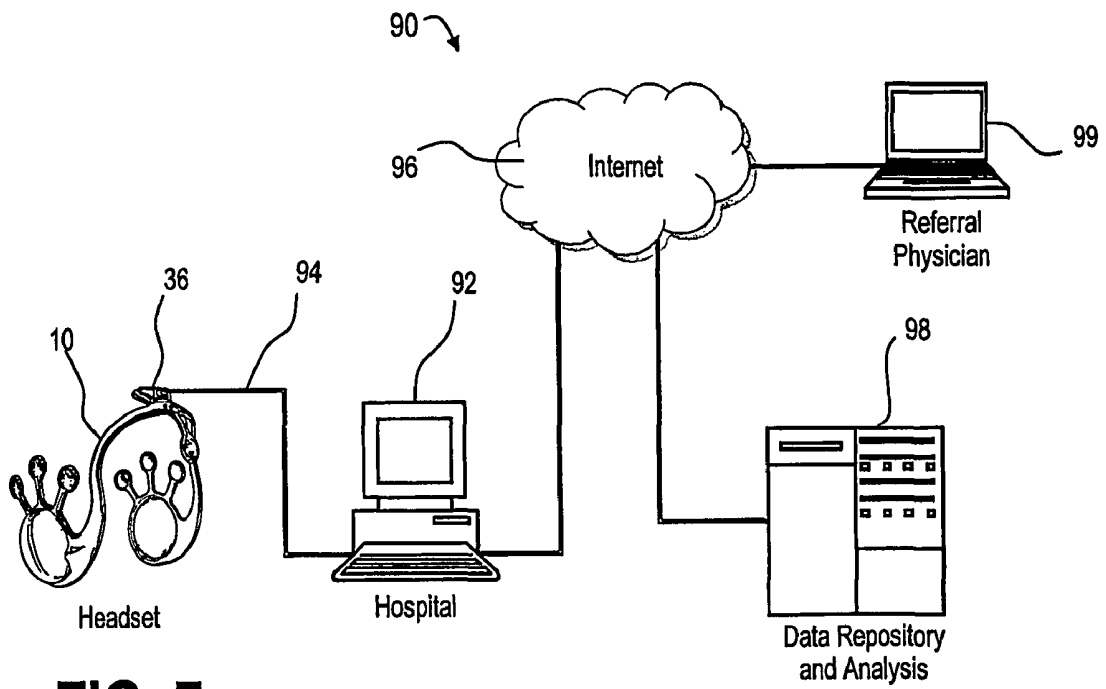

FIG. 7

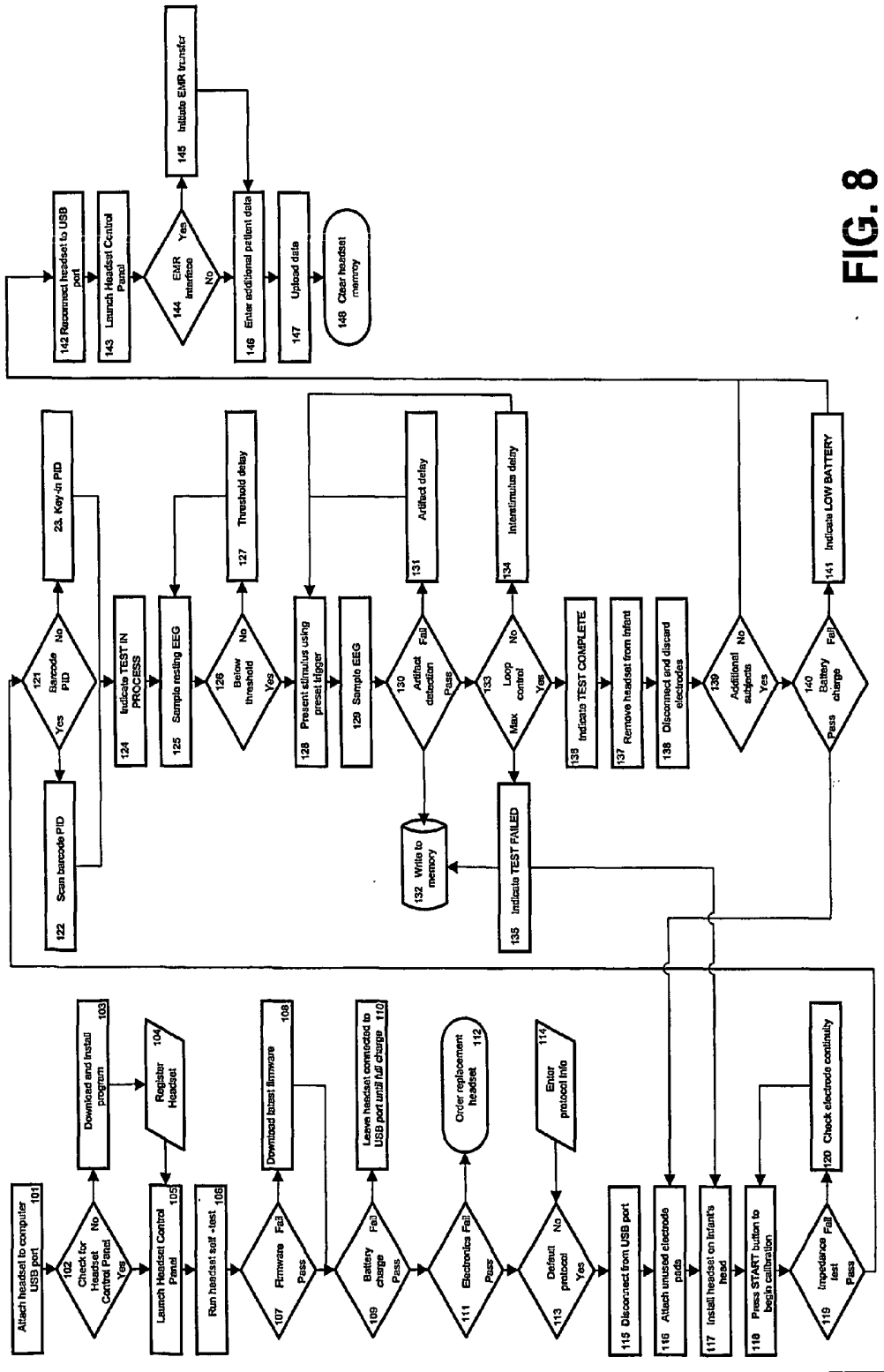

FIG. 8

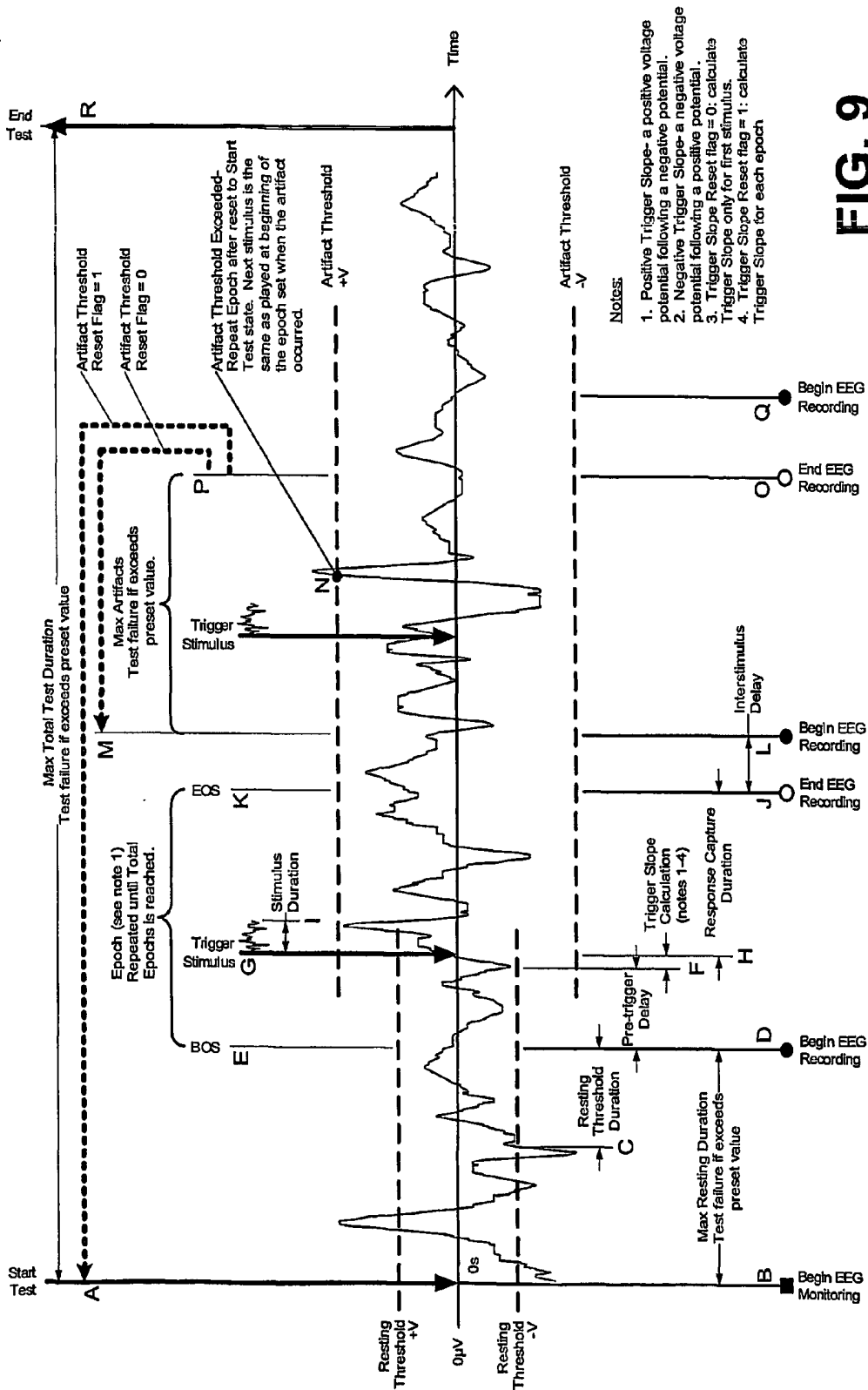

FIG. 9







Stimulus Library		
Click		Narrow band spike
Burst		Broadband short duration
Pip/Chirp		Single frequency half-cycle carrier
Steady-State Tone		Single frequency constant amplitude
MASTER		Single frequency continuous cycles
Phoneme		Single-phoneme speech sound
Word		Word

FIG. 10



EPOCH - a stimulus presentation and data capture event

AUDIOMETRY FIV STEP - a series of EPOCH's where the frequency is held constant and the volume is incremented through a preset range

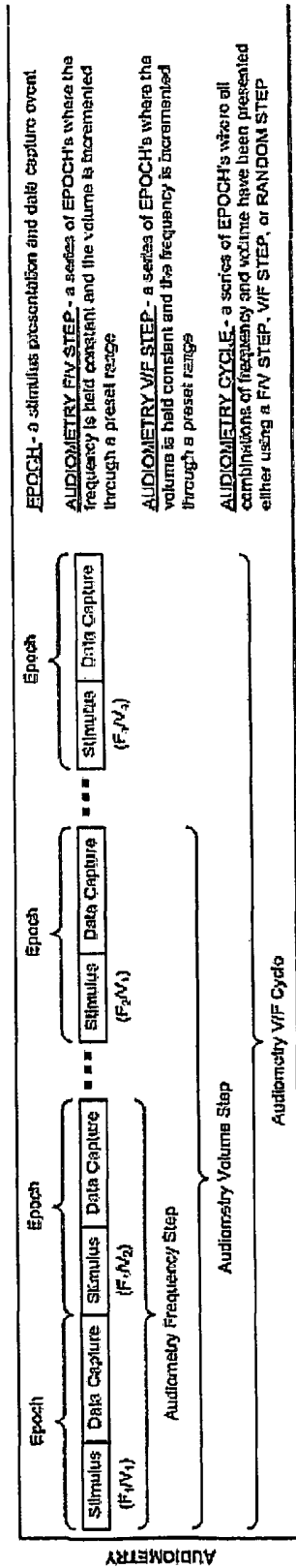
AUDIOMETRY VIF STEP - a series of EPOCH's where the volume is held constant and the frequency is incremented through a preset range

AUDIOMETRY CYCLE - a series of EPOCH's where all combinations of frequency and volume have been presented either using a FIV STEP, VIF STEP, or RANDOM STEP

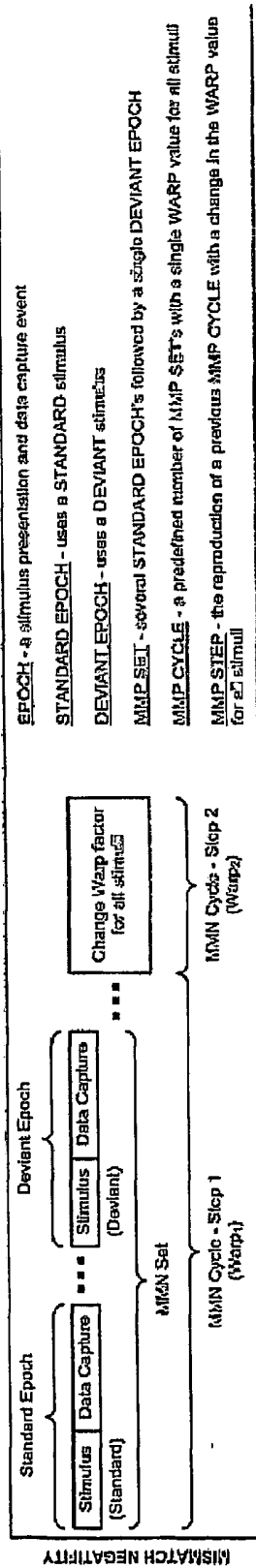

EPOCH - a stimulus presentation and data capture event

STANDARD EPOCH - uses a STANDARD stimulus

DEVIAINT EPOCH - uses a DEVIAINT stimulus

MNP SET - several STANDARD EPOCH's followed by a single DEVIAINT EPOCH

MNP CYCLE - a predefined number of MNP SET's with a single WARP value for all stimuli

MNP STEP - the reproduction of a previous MNP CYCLE with a change in the WARP value for aJ stimuli

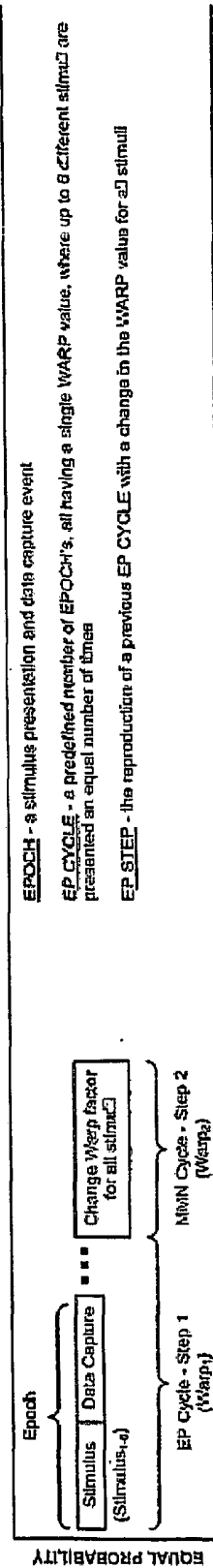

EPOCH - a stimulus presentation and data capture event

EP CYCLE - a predefined number of EPOCH's, all having a single WARP value, where up to 8 different stimuli are presented an equal number of times

EP STEP - the reproduction of a previous EP CYCLE with a change in the WARP value for aJ stimuli

FIG. 11

**METHOD AND SYSTEM FOR AN AUTOMATED
E.E.G. SYSTEM FOR AUDITORY EVOKED
RESPONSES**

CROSS REFERENCE TO RELATED
APPLICATION

[0001] The present application hereby claims the benefit of the U.S. provisional patent application of the same title, Ser. No. 60/479,684, filed on 19 Jun. 2003 and claims the benefit of the U.S. provisional entitled "ACTIVE, MULTI-PLEXED DIGITAL NEURO ELECTRODES FOR EEG, ECG, EMG APPLICATIONS" 60/557,230, filed on 29 Mar. 2004, the disclosure of both being hereby incorporated by reference in their entirety. The present application is related to the co-pending and commonly-owned application filed on even date herewith entitled "AUDITORY EVOKED RESPONSE MAPPING SYSTEM FOR AUDITORY NEURROME" to K. C. Fadem, the disclosure of which is hereby incorporated by reference in its entirety.

FIELD OF THE INVENTION

[0002] The present invention relates generally to a method and apparatus for capturing electroencephalogram (EEG) signals. More particularly, the present invention provides a method and describes a system for the purpose of diagnosing dyslexia, and similar neurological conditions such as autism, schizophrenia, etc., by capturing brain waves produced while processing a preprogrammed auditory stimulus.

BACKGROUND OF THE INVENTION

[0003] Dyslexia is an inborn condition characterized by abnormal brain physiology or "defective wiring". Detailed studies of the brains of known dyslexics show a marked difference from normal brains. This physical difference has been detected with a variety of brain imaging modalities including: MRI, CT, and PET. The pathophysiology is characterized by a disruption in left hemisphere posterior reading systems, primarily in left temporo-parieto-occipital brain regions, with a relative increase in brain activation in frontal regions (Shaywitz, et al. "Dyslexia Specific Reading Disability", *Pediatrics in Review*, Vol. 24, No. 5, May 2003).

[0004] Dyslexia effects about 10-15% of the population to varying degrees and manifests as difficulty reading, inability to concentrate, and various other learning disabilities. Surprisingly, dyslexia is unrelated to low I.Q. and is common in many successful and motivated people. Examples of recognized dyslexics include Einstein, Edison, Ford, Patton, da Vinci, Rockefeller, Churchill, Disney, and others (from www.dyslexia.com). Dyslexia is not a chemical imbalance or behavioral disorder like Attention Deficit Hyperactivity Disorder (ADHD) and can't be treated with drugs such as Ritalin as used in some ADHD children.

[0005] Typically, dyslexia is not diagnosed until between ages 5 and 8, usually after the child has fallen two grade levels behind in reading. By this time, much of the permanent damage to the child has already been done. Parents of dyslexic children are often forced to endure the difficulties of raising a child who has been labeled as "slow", "disruptive", or a "problem-child". Sometimes these dyslexic children are misdiagnosed as ADHD. These children may be put on drug therapy in hopes of controlling disruptive behaviors. While this may have some mitigating impact on the school

system, this kind of therapy will have no beneficial direct effect on the dyslexia itself. The longer-term negative effects include illiteracy, anti-social behavior, and low income.

[0006] Recent evidence has shown that dyslexic brains can be remodeled or retrained to overcome the wiring defect (Simos, et al., "Dyslexia-specific brain activation profile becomes normal following successful remedial training", *Neurology* 2002; 58:1203-1213). Many experts believe that intervention will be most effective early in a child's life ("A New Era: Revitalizing Special Education for Children and Their Families", President's Commission on Excellence in Special Education, Jul. 1, 2002). Early detection is the key mitigating the lifelong effects of dyslexia.

[0007] Most current dyslexia screening tests measure obscure, anecdotal, action-response behaviors. Some tests include posturography which measures balance strategies, bead threading which measures sequential memory, rhyming games which measure phonological awareness, and others. These tests can only be given to a child who is old enough to perform reading, puzzle solving, or other high-level assessment skills. None of these tests directly detect the underlying physical brain wiring defect. Poor performance on these tests could be attributed to causes other than dyslexia.

[0008] In 1929, the German psychiatrist, Hans Berger, announced to the world that: "it was possible to record the feeble electric currents generated on the brain, without opening the skull, and to depict them graphically onto a strip of paper . . . that this activity changed according to the functional status of the brain, such as in sleep, anesthesia, hypoxia (lack of oxygen) and in certain nervous diseases, such as in epilepsy." (Berger, H., "Uber das elektroencephalogramm des menschen", *Archiv fur Psychiatrie und Nervenkrankheiten*, 1929, 87:527-580). Berger named this new form of recording as the electroencephalogram (EEG).

[0009] Electroencephalograms or EEG's are voltage potentials measured on the scalp produced during brain activity where the magnitude of the voltage differentials is plotted versus time. An EEG system is composed of several discrete system components. The first component is a conductive electrode that is placed on the scalp generally in close proximity to an inactive part of the brain. This inactive or "reference" electrode is used as a reference for other "active" electrodes placed on the scalp in close proximity to processing areas of the brain. The electrodes are electrically connected to voltage amplifiers, bandpass filters, and various other electronic components generally used in processing electronic signals. In most current systems, the analog voltage signal is passed through an analog to digital converter where the signal is sampled at a user-controlled rate and converted to digital data. The digital data may then be stored on digital media for later processing.

[0010] The most important requirements for clinical application of EEG's were described in 1947 in U.S. Pat. No. 2,426,958 by Ulett. The electrode and placement technique associated therewith should be such that the electrode produces no artifacts; is easy to apply, keep on, and remove; and, it is relatively cheap in production and painless in its application and use.

[0011] EEG measurements from auditory evoked responses (AER) detect voltage potentials from the brain as

the brain attempts to discriminate a sound. EEG's from dyslexic children show abnormally high peak voltages and signal latencies. These characteristics correlate to higher than normal energy requirements to process sounds and slower discrimination and sound-to-symbol mapping, the outward manifestations of which will primarily be difficulty in reading and writing.

[0012] A body of research has been performed by Drs. Dennis and Victoria Molfese to develop and scientifically validate the use of AER's to diagnose dyslexia in infants so that earlier and more effective intervention is possible. (Molfese, D., "Predicting Dyslexia at 8 Years of Age Using Neonatal Brain Responses", *Brain and Language* 72, 238-245 (2000); Molfese, et al, "Newborn and Preschool Predictors of Second-Grade Reading Scores", *Journal of Learning Disabilities*, No. 6, November/December 2001, pp 545-554; and Molfese, et al, "The Use of Brain Electrophysiology Techniques to Study Language: A Basic Guide for the Beginning Consumer of Electrophysiology Information", *Learning Disability Quarterly*, Volume 24, Summer 2001, pp. 177-188). In particular, this research has identified optimum positions on the subject's scalp for picking up these characteristic electrical potentials and for identifying an AER characteristic of dyslexia.

[0013] While this research into AER diagnosis of dyslexia has been of scientific interest, diagnosis of dyslexia in infants is not common in a clinical setting. By contrast, hearing deficits affect only about 1 in 500 newborns whereas dyslexia affects 50 times as many children, yet the Universal Newborn Hearing Screening (UNHS) test is mandated in 38 states. Therefore, approximately 69% of the 4,000,000 children born in the U.S. each year have this UNHS test performed soon after birth. The UNHS test uses a similar EEG technology to measure brainwaves from the brain stem or "unconscious" part of the brain as a result of an auditory stimulus.

[0014] At least part of this disparity in clinical use is believed to be the testing equipment required for dyslexia AER diagnosis. The UNHS test only verifies the connection between the ear and the brain stem. As such, a relatively simple diagnostic analysis is required to detect the presence of brain stem response to a sound. The dyslexia AER diagnosis requires a more subtle comparison of characteristic waveforms for optimum auditory processing in the normal population compared to a sub-optimum auditory processing in the dyslexic population. Such sophisticated processing makes this analysis unpractical for the relatively untrained staff in a neonatal care unit.

[0015] Moreover, unlike UNHS testing wherein measurements from a single active electrode are used, dyslexia AER testing requires a time consuming process of attaching and taking measurements from several electrodes. Not only does the test preparation and locating of electrodes require some expertise, so does recognition as to whether a sufficient signal is being detected for analysis to be performed. Even under the best of circumstances, the signal-to-noise ratio (SNR) of AER is low.

[0016] Yet a further disincentive to clinical use of dyslexia AER testing is the fact that a desired test population are newborn infants. Known electrode attachments and analysis equipment are cumbersome, imposing in appearance, with

long and potentially dangerous wiring harnesses, tending to disconcert parents and other visitors to maternity wards who may witness the test.

[0017] Consequently, a significant need exists for an AER (e.g., dyslexia) testing device and method that is suitable for widespread clinical use.

BRIEF SUMMARY OF THE INVENTION

[0018] The invention overcomes the above-noted and other deficiencies of the prior art by providing a screening device that is simple to use in a clinical environment. A headset is readily engageable to a head of an infant subject and positions an electrode on a reference location on the head, such as the cheek or forehead or other portion, and positions a signal electrode advantageously with regard to the infant's ear. This signal electrode is thus readily positioned proximate to the auditory processing locations on the infant's head to sense an Auditory Evoked Response (AER) after an auditory stimulus is given to the infant. Simplified electrode placement allows clinical use by those without having specific neurological training.

[0019] In one aspect of the invention, the headset device positions the electrodes for convenient data acquisition and further stores the AER data after the auditory stimulus for later uploading via a communication link to a data analyzer. Thereby, the expense of a data analyzer is removed from the device, allowing one data analyzer to be more efficiently used to support a large number of devices. Moreover, the headset device is more portable and less intrusive for use in various clinical settings.

[0020] These and other objects and advantages of the present invention shall be made apparent from the accompanying drawings and the description thereof.

BRIEF DESCRIPTION OF THE FIGS.

[0021] The accompanying drawings, which are incorporated in and constitute a part of this specification, illustrate embodiments of the invention, and, together with the general description of the invention given above, and the detailed description of the embodiments given below, serve to explain the principles of the present invention.

[0022] FIG. 1 is a perspective view of an integrated Auditory Evoked Response (AER) headset for clinical screening for AER mapping (e.g., dyslexia) in infants.

[0023] FIG. 2 is a close-up view of an electrode attached to one of the headset's flexible arms.

[0024] FIG. 3 is a perspective view of the AER headset of FIG. 1 with one clamshell cover removed.

[0025] FIG. 4 is a top view of a flex-circuit electronic harness for the AER headset of FIG. 1.

[0026] FIG. 5 is a functional block diagram of a controller of the AER headset of FIG. 1.

[0027] FIG. 6A is a top diagrammatic view of a recurved frame and earpieces of the AER headset of FIG. 1, shown in a relaxed position.

[0028] FIG. 6B is a top diagrammatic view of the recurved frame and earpieces of the AER headset of FIG. 6A, shown in an expanded position.

[0029] FIG. 7 is a block diagram of the AER headset of FIG. 1 as part of an auditory evoked response mapping system.

[0030] FIG. 8 is a flowchart describing a procedure or sequence of operations performed by the AER headset of FIG. 1 to stimulate, capture, and analyze EEG's.

[0031] FIG. 9 is a graph of EEG auditory evoked response as a function of time illustrating a screening schema for AER analyses such as peak latency, cognitive functional significance, cortical distributions, and component brain sources.

[0032] FIG. 10 is a table of a stimulus library maintained and utilized by the auditory evoked response mapping system and/or the AER headset of FIG. 7.

[0033] FIG. 11 is a diagram of an illustrative AER protocol for audiometry, mismatch negativity, and equal probability testing performed as part of the auditory evoked response mapping system of FIG. 7.

DETAILED DESCRIPTION OF THE INVENTION

[0034] In the drawings where like members are given the same reference numeral, in FIG. 1, an integrated Auditory Evoked Response (AER) headset 10 includes embedded features that enable clinicians to readily perform an electroencephalogram (EEG) test without the necessity of extensive training. Portability of diagnostic data taking allows use whenever and wherever desired. Economy of use is achieved by centralized processing of the diagnostic data so that a great number of headsets 10 may be used without the necessity of expensive waveform processing equipment at each location. Collecting data from many screened individuals enables enhanced and improved diagnostic algorithms to be created and implemented. Furthermore, the headset 10 includes features that speed its use while avoiding human error and the need for extensive training.

[0035] To these ends, the headset 10 incorporates a control module 12 that advantageously allows the headset 10 to be portable and to be used in a clinical setting by including pre-loaded or downloadable testing protocols managed by the control module 12, enhancing ease of use. The headset 10 further includes an elastic, semi-rigid frame 14, which contains the control module 12. In particular, the frame 14 automatically positions six conductive electrode plugs ("electrodes") 16 via flexible arms 18 to specific positions 20 relative to the subject's ears correlating to portions of the brain responsible for auditory processing. These flexible arms 18 are advantageously cantilevered to exert a force upon the electrodes 16 to assist in obtaining good electrical contact with the subject's skin. In the illustrative embodiment, this alignment is assisted by the recurved frame 14 oriented to pass over the forehead. This convenient positioning greatly simplifies the generally accepted practice of manually positioning each electrode on the scalp in reference to a central point. A similar reference electrode plug 16' is positioned by flexible arm 18' to a forehead location 22 of the subject, this point selected for being relatively at an electrical ground potential relative to the auditory processing locations and for being readily accessible with a supine subject.

[0036] Each electrode plug 16, 16' contacts the subject's skin via an electrode pad 24, 24' that includes electrical

contacts to pick up the voltage signal of the AER. The frame 14 and flexible arms 18, 18' exert a force respectively upon each electrode plug 16, 16' and electrode 24, 24' to achieve a good electrical contact. Each electrode pad 24, 24' may be individually replaceable to ensure proper operation and/or sterilization requirements. Alternatively, a larger portion of the headset 10 may be replaceable for such reasons. Yet a further alternative may be that the electrodes 24, 24' may be compatible with sterilizing agents, such as an alcohol wipe. The electrode pads 24, 24' may support or incorporate an electrically conductive substance such as saline to enhance electrical contact. Alternatively or in addition, the electrode plugs 16, 16' and electrode pads 24, 24' may incorporate a pneumatic seal when manually depressed against the subject's skin, or even further include an active pneumatic suction capability to achieve good contact.

[0037] Fluid-filled bladders (not shown) may be advantageously incorporated into portions of the headset 10, such as inside the ear cups and electrodes, in order to provide a uniform contact with the subject's head, reducing discomfort and the likelihood of impedance variations. Alternatively, a resilient material (e.g., foam, gel) may be used instead of fluid-filled bladders.

[0038] An exemplary electrode 24, 24' may employ an active digital electrode approach for incorporation into the headset 10 to address the need for sensitivity, enhanced signal to noise performance, and economy, described in greater detail in the afore-mentioned patent application entitled "ACTIVE, MULTIPLEXED DIGITAL NEURO ELECTRODES FOR EEG, ECG, EMG APPLICATIONS".

[0039] In FIGS. 1 and 3, the frame 14 also supports ear cups (earpieces) 26 that position sound projectors 28 in front of the respective subject's ear. The headset 10 includes a speaker 30 for each ear that generates an auditory signal in response to an electrical signal from the control module 12. Each speaker 30 may be in a respective ear cup 26. Alternatively, each speaker 30 may be proximate to the control module 12, such as a piezoelectric transducer, that generates a sound that is directed through a pneumatic sound tube (not shown) to the sound projector 28 in the ear cup 26. This latter configuration may have advantages for having a replaceable ear cup assembly wherein active components are relegated to a reusable portion or where the active components are externally coupled to a passive, perhaps disposable headset. An electrode (not shown) may advantageously be included in the ear cup 26 for ensuring location caudad to the sylvian fissure.

[0040] When the headset 10 is used, simplified indications and controls 32 let the clinician know that the headset 10 is operational. For instance, an indication may be given that sufficient battery power exists, that the electronic components have passed a built-in test, etc. Thereby, the clinician, even with little specific training into the AER waveform analysis, is able to readily perform the data acquisition on the subject.

[0041] Although the headset 10 may include all of the functionality required to perform a (e.g., dyslexia) AER testing protocol, the headset 10 advantageously accepts an external electrical connector 34 at an interface 36 so that additional functionality may be selectively used. For instance, rechargeable batteries (not depicted in FIG. 1) in the headset 10 may be charged. The interface 36 may accept

subject identification information to be linked with the diagnostic data taken. For instance, a personal computer, personal digital assistant, or a keyboard may be interfaced to the headset **10** as a means to input subject identification information. An illustrative input device, depicted as an identity scanning device **38**, such as the OPTICON PN MSH-LVE4100 barcode scanner module integrated into the control box **41**, is activated by a push button **40** presented upon a control box **41** to read a patient identification band **42**. The illustrative identity scanning device **38** advantageously has a short reach via cable connection **43** to minimize the likelihood of misidentifying the subject being tested. The identity scanning device **38** may advantageously sense alternatively or in addition to barcodes other indicia of identity, such as by passive radio frequency identification (RFID) (e.g., PHILIPS PN HTRM440), fingerprint scanning, or manual keypad entry via an input device coupled or attached to a control box. Furthermore, such control box functions may be integrated into the headset rather than being tethered thereto.

[0042] It should be appreciated by those skilled in the art having the benefit of the present disclosure that a hard-wired interface **36**, such as a Universal Serial Bus (USB) interface, may be used as depicted or a wireless connection may be made, such as using the BLUETOOTH standard or other type of link.

[0043] Furthermore, a barcode identifier may be a one-dimensional or a two-dimensional barcode. Similar, the identifying information may be in the form of an embedded radio frequency (RF) target that puts off a unique return when energized by an RF carrier signal. Other types of identifying information may be used consistent with aspects of the present invention.

[0044] FIG. 2 depicts the flexible arm **18**, **18'** supporting the electrode plug **16** annotated to denote resilient characteristics inherent so that a good electrical conduct is achieved. It will be appreciated that wiring or conductive ink applied to or formed therein may be used to electrically couple the electrode plug **16**, **16'** to the control module **12**.

[0045] In FIG. 3, the electrodes **16** and **16'**, along with the speaker **30** are captured in a clamshell cover **43**. One or more active electrodes **16** may be a high frequency electrode which has been set to capture brainwaves at around 20,000 Hz. Disposable electrode contact pad **24**, shown detached, may be impregnated with an electrolytic gel to lower impedance. This headset **10** includes three different types of electrodes.

[0046] High frequency electrodes **16**, reference electrodes **16'** at the patient's cheek, and low frequency electrodes **16''**. As mentioned before, some electrodes **16** advantageously achieve good electrical contact via cantilevered flexible arms **18** while those closely coupled to the ear cups **26** receive a similar inward force from the recurved frame **14**.

[0047] In FIG. 4, a flex-circuit electronic harness **50** is depicted as an economical fabrication approach with the electrodes **16**, **16'**, interconnects, and other headset electronics integrated onto a flexible printed circuit **52**. Electrode electronics **54**, control electronics **56**, earpiece electronics **58**, and electrode pad connectors **60** are electrically connected to flexible printed circuit **52** at flexible circuit areas **62**, **64**, **66**, **68** respectively. Thus, an advantageous flex-

circuit electronic harness **50** lends itself to being shaped to a subject's cranium and to being exteriorly cantilevered into a good electrical contact with the subject's skin.

[0048] FIG. 5 depicts an illustrative control module **12** of the headset **10** formed as an electronic circuit **70**. It should be appreciated that the electronic circuit **50** may advantageously be produced in large-scale production as a custom Application Specific Integrated Circuit (ASIC) wherein all or many of these and other functions are incorporated into a single silicon wafer.

[0049] In the illustrative version, a number of discrete devices are used to perform the acquisition of AER data. The electrodes **16**, **16'** produce a low voltage signal that is selectively transmitted to the control box **41** by a multiplexer **72**. At least one electrode **16**, **16'** may advantageously be designed for high frequency data capture (e.g., typical sampling rate of 20,000 Hz) and/or at least one electrode may be designed for low frequency data capture (e.g., typical sampling rate of 250 Hz). The gain, filters, and A/D conversion settings may thus be different to accommodate the differences in signal characteristics. In particular, the high frequency electrode(s) may be used to capture low amplitude, high frequency brainwaves as in auditory brainstem response (ABR) testing for hearing defects. The low frequency electrode(s) may be used to capture higher amplitude, lower frequency brainwaves like the middle latency response (MLR) and the late latency response (LLR or slow-wave). These waves are commonly used to detect auditory processing disorders (APD), attention deficit disorder (ADD), and dyslexia.

[0050] The multiplexed signal therefrom is received by an integrated memory **54**, such as a TOSHIBA, Part. No. TC58128 AFT, 128 MB 3.3 V Flash Memory in a 48 Thin Small-Outline Package (TSOP) Surface-Mount Technology (SMT) package. The memory **74** receives input data from external devices, such as the barcode scanner **38** via the interface (e.g., USB port) **36**. The memory **74** is also preloaded or uploaded with a testing protocol and stores a number of testing session data records so that the headset **10** may be repeatedly used prior to uploading results.

[0051] The processing is performed by a microcontroller **76**, such as MICROCHIP PIC16C765-I/PT, which advantageously includes analog-to-digital (A/D) Converters and USB Communication capability. An example of the processing includes sending a predetermined number of audio signals of a predetermined pitch, volume and duration or a previously recorded and digitized sound, and recording the resultant AER waveform. In particular, the microcontroller **76** may communicate with the multiplexer **72** to control which electrodes **16**, **16'**, **16''** are being sampled. The electrodes can be turned on and off in a serial fashion to capture early, high frequency waves and later, low frequency waves evoked from the same initial stimulus. This will produce optimized signal detection with a minimum of file size.

[0052] The desired audio signals are produced by a digital sound card **78**, such as by WINBOND ELECTRONICS, ISD4002-150E, "Single-Chip Voice Playback Device" that produces the audio signals on speakers **30**. The electronic circuit **70** is powered by a power supply **80**, such as an ULTRALIFE UBC502030, Rechargeable 200 mAh battery.

[0053] In FIGS. 6A-6B, headset frame **14** is recurved such that when a force **F** is applied, as when there is a need for

the headset **10** to be installed on a large head increasing the distance from A to A', the bending angle B of the ear cup **26** in the general area **82** aft of the ear cup **26** of the headset frame **14** is equal to the bending angle C of the headset frame **14** in the general area **84** forward of the ear cup **26**. This will keep the orientation of the left and right earpieces **26**, with respect to the subject's ears, the same for a broad range of head sizes.

[0054] FIG. 7 depicts an AER (e.g., dyslexia) screening test system **90** that advantageously provides for economical testing, billing, long-term data storage and analysis for analysis refinement, subsequent therapeutic measures, and other features. To this end, the headset **10** may be in electrical communication with a hospital system **92** via a cable or wireless link **94** so that accomplishment of the dyslexia screening test is noted for patient health records and for billing records. Also, the hospital system **92** may facilitate communication across a network, such as the Internet **96**, to a remote processing facility, depicted as a data repository and analysis computer **98**.

[0055] This data repository and analysis computer **98** allows for the most up-to-date waveform recognition techniques to be employed to diagnose a dyslexia condition. Moreover, the computer **98** may process a number of data from screening tests to make such analysis more cost effective. Moreover, historical data may be mined as recognition techniques improve to capture previously undiagnosed conditions or to otherwise correlate previous test results with other forms of data to further refine the diagnostic process. It should be appreciated that the analysis performed by the data repository and analysis computer **98** could further include neural net processing, wherein the neural net is trained to recognize a waveform characteristic of dyslexia or other conditions.

[0056] Positive, inconclusive, and/or negative screening test results may be forwarded to an appropriate recipient, such as a referral physician **99** for further diagnostic testing and/or therapeutic measures.

[0057] FIG. 8 depicts an illustrative procedure or sequence of operations **100** for AER (e.g., dyslexia) screening performed by the test system **70** of FIG. 7. In block **101**, the headset is attached to a computer USB port. If determined that the headset control panel indicates the need for initializing the headset (block **102**), then a headset program is downloaded and installed (block **103**) and the headset identification number and initialization status is registered (block **104**). If initialization is not needed in block **102** or after registering in block **104**, then the headset control panel is launched (block **105**) and a self-test is performed by the headset (block **106**). If the firmware is determined to have failed (block **107**), then the latest firmware may be downloaded (block **108**). If the battery is determined to have failed a charge test (block **109**), then the headset is left connected to the USB port until fully charged (block **110**). If the electronics self-test fails (block **111**), then an indication is given to the user or electronically transmitted back via the USB port to order a replacement headset (block **112**). If the user inputs that default protocol is not to be used (block **113**), then the headset receives protocol information from the user, perhaps input through the control box or from a PC interface (block **114**). In block **115**, the headset is disconnected from a hospital computer or other device after a previous upload of screening test data, download of an updated test protocol, and/or charging of the batteries in the headset. The headset is prepared for the next subject by

ensuring that the headset is sterile and has operable electrodes. One way is as depicted in block **116** by attaching an unused electrode pad to each of the electrode arms.

[0058] With the headset ready, the headset is placed upon an infant subject's head. The frame of the headset simplifies placement by including ear cups and a forehead frame to be aligned with the subject's eyebrows that intuitively guide the clinician in proper placement (block **117**). This includes properly positioning reference electrodes at the patient's cheeks, although other predetermined reference locations may be selected, such as the forehead. Simplified initiation of the test is provided by depressing the start button on the attached control box (block **118**). The headset interprets this button push and initiates a self-test to verify good reception of an EEG signal from the subject (e.g., impedance test) (block **119**). The self-test is indicated on the headset indicator LED lights or control box. If failed, the clinician removes the headset from the infant's head and checks electrode continuity (block **120**), which may entail visually checking for good electrode contact and/or reconnecting the headset to a hospital device to evaluate the cause of the failure (block **120**). For instance, the headset may provide a more detailed explanation of the failure over the interface.

[0059] If in block **108** the self-test was deemed a pass, then a determination is made as to whether a machine readable patient identification (PID) such as a barcode is available (block **121**). If so, the clinician uses the scanning device to scan in a PD code from the subject (block **122**), else the PID is manually keyed in (block **123**). The headset responds by giving an indication of a test in process so that the clinician leaves the headset undisturbed (block **124**). Then, the headset samples resting EEG at the various electrodes (block **125**). This sampling includes making a determination whether an EEG voltage is below a threshold indicative of a resting, unstimulated state (block **126**), and if not, a threshold delay is imposed (block **127**), looping back to block **125**. Else, if the appropriate initial condition is found in block **126**, then a stimulus is presented using a preset trigger defined by the protocol (block **128**). The EEG is then sampled at the appropriate combination of electrodes and at a sample rate appropriate for the frequency of interest (block **129**).

[0060] Another feature that may enhance consistent results is defining an initial starting point on the same slope of a detected resting brainwave (e.g., rising slope, falling slope, apex, nadir).

[0061] Advantageously, the headset performs a data integrity check, such as by comparing the sampled data against various criteria to detect artifacts indicative of noise or external stimuli that corrupted the data sample (block **130**). If detected, then an artifact delay is imposed (block **131**) before looping back to block **128**. Else, the data samples are written to memory in the headset (block **132**), including storing the PID for tagging to the screening test data. Typically, the test protocol includes a series of stimuli and samples. Thus, a determination is made that another control loop is to be performed (block **133**). If so, an appropriate interstimulus delay is imposed to return to a resting EEG (block **134**) followed by looping back to block **128**. However, if more control loops are warranted but a threshold is exceeded for a maximum time or a maximum number of attempts, then the test failed indication is given (block **135**) and the procedure returns to block **117** for the clinician to reposition the headset for retesting. If, however, in block **133** the inner and outer control loops that define the testing

protocol are deemed complete, then a test complete indication is given to the clinician (block 136), such as by illuminating an appropriate LED light.

[0062] If test complete is determined in block 136, then the headset is removed from the infant subject's head (block 137) and the used electrode pads are removed and discarded from the headset (block 138). If another subject is to be tested prior to uploading screening test data (block 139), a battery charge check is made (block 140) to see if the remaining charge is sufficient. If it passes, then processing loops back to block 116 to prepare the headset for the next subject. If failed, then a low battery indication is given (block 141).

[0063] If no additional subjects are determined in block 139 or if low battery is determined in block 141, it is time for reconnecting the headset to the USB port of the hospital computer (block 142), which recharges the headset and also provides an opportunity to activate an Internet connection to initiate data upload and any new test protocol download. In particular, a headset control panel is launched for interacting with the clinician (block 143). If an electronic medical record (EMR) interface is determined to be available (block 144), then an EMR transfer is initiated (block 145). If EMR transfer is not available or after EMR transfer is initiated, then the clinician is afforded an opportunity to enter additional patient data (block 146). The data is uploaded to the AER system (remote user) for analysis and disposition (block 147)

[0064] For instance, the remote user may perform diagnostic analysis on the received screening test data to see if the AER data is indicative of dyslexia. If a determination is made that the results are not positive for dyslexia, then the appropriate recipient is informed, such as the parent or the attending pediatrician or obstetrician. If positive, then the test results may be advantageously forwarded to an in-network referral physician, such as a child psychologist.

[0065] In FIG. 9, a timing chart illustrates a sequence of events involved in an AER test. At time "T_A" the test subject's barcode wristband is scanned and the test begins. Concurrently, the headset begins monitoring the brainwaves at time "T_B" to identify when the amplitude of the resting brainwaves falls below the preset resting threshold at time "T_C" and remains there for a preset duration. This begins the recording of the brainwaves at time "T_D". This point is called beginning of series (BOS), at time "T_E". Next, the headset calculates the slope of each subsequent brainwave at time "T_F" and triggers the stimulus when the slope criteria is met at time "T_G" beginning a response capture period at time "T_H". The stimulus is generally of short duration at time "T_I". At the end of the response capture period, the brainwave recording stops at time "T_J". For a single stimulus series, this is called end of series (EOS) at time "T_K". Time sequence from time "T_E" to time "T_K" defines the first epoch. A predetermined interstimulus delay passes at "T_L" before the next epoch at time "T_M" is begun. During the next epoch, the chart shows an artifact where the amplitude of the recorded brainwave exceeds the artifact threshold at time "T_N". At the end of this epoch the EEG recording stops at time "T_O" and the sequence is redirected at time "T_P" back to the beginning of series at time "T_M" if the artifact threshold reset flag is set to "1" or to before the resting threshold at time "T_A" if the flag is set to "0". If the artifact threshold is not exceeded, a new epoch is begun at time "T_Q". The test ends when all epochs are completed or when the total test time is exceeded at time "T_R".

[0066] In FIG. 10, an illustrative stimulus library is depicted having seven general types of stimulus, representing the kind of stimuli that can be downloaded into headset memory to be used to evoke a brainwave response. Any recorded, or synthesized audio stimulus may be used with this list being merely exemplary. In particular, the library may include a click that is of a narrow frequency band of extremely short time duration (i.e., spike), a burst that is a broadband signal of short duration.

[0067] In Table 1, an illustrative configuration table lists data capture settings that may be accessed, selected, modified, or otherwise utilized by the headset 10 to adapt its testing capabilities. For instance, a range of preset electrode locations may be configurable, for example 10 to 20 locations identified by an electrode location label. For instance, a selected headset 10 with its choice of cantilevered arms and electrode placements may use a subset of available locations. However, the system is capable of being used with different locations. Data capture start and end defines what latency is expected for the brainwave of interest. Signal gain sets amplification as appropriate for the particular electrode location, brainwave of interest, and perhaps a detected impedance/resting brainwave pattern. In addition, artifact detection parameters may be advantageously incorporated so as to determine if a particular AER test did not receive an undisturbed result. This artifact detection may be a voltage threshold that should not be exceeded during the data sampling.

TABLE 1

Data Capture Settings	
Electrode Location	Location I.D. using 10-20 system
Electrode Selection	Which electrodes will be selected for data capture
Data Capture Start-End	When should the data capture begin and end
Data Capture Rate	At what rate should the system sample the electrodes to capture data
Signal Gain	Signal amplification
Artifact Threshold	Voltage threshold to be used to instruct the system when to replay the stimulus set

[0068] Table 2 represents the kind of sequences that can be downloaded into the headset memory to be used to evoke a brainwave response. User-defined sequences may also be used.

TABLE 2

Sequence Library	
Repetition	Repeat single stimuli
Steady-State	Single tone with long duration
Equal Probability	Multiple stimuli repeated, each repeated an equal number of times
Oddball Paradigm (MMN):	Single standard stimuli with one or more deviant stimuli
Variable Frequency	Constant volume, vary frequency
Variable Volume	Constant frequency, vary volume
Variable Time Warp	Constant tone, vary duration
User Defined	User defined sequence presentation, volume, tone, and time warp

[0069] In FIG. 11, the integrated AER headset 10 performs a selected or predefined protocol that detects an AER for mapping, illustrated by a protocol that includes audiometry, mismatch negativity, and equal probability testing such as may be performed as part of the procedure 100 of FIGS. 8

and 9. The headset 10 references characteristics of each epoch, which includes a stimulus presentation and a data capture event, to be performed within an audiometry frequency step. One or more audiometry frequency steps in turn comprise an audiometry volume step. One or more audiometry volume steps in turn comprise an audiometry volume/frequency cycle. Thus, the audiometry frequency/volume step combination holds a selected increment of frequency constant while stepping through volume increments before moving onto a different frequency increment. Thereby, the subject's hearing sensitivity at various frequencies is determined.

[0070] Variations in the audiometry cycle may be selected. For instance, an audiometry volume/frequency step combination entails a series of epochs wherein the volume is held constant and the frequency is incremented through a preset range before moving onto another increment of volume. As another example, an audiometry random step combination performs each combination of frequency and volume increment but in a random order.

[0071] In a mismatch negativity (MMN) set, several standard epochs are included with a deviant epoch having a deviant stimulus. A predefined number of MMN sets are performed with a single warp value for all stimuli to perform an MMN cycle. Then, another MMN step is performed as a reproduction of the previous MMN cycle but with a change in the warp value for all stimuli.

[0072] In an equal probably (EP) screening, an EP cycle includes a predetermined number of epochs, all having a single WARP value wherein up to 6 different stimuli are presented an equal number of times. An EP step is a reproduction of a previous EP cycle with a change in the WARP value for all stimuli.

[0073] In use, a headset 10 advantageously integrates sound projectors (earphones) 28 and flexible electrode arms 18, 18' that easily and accurately position electrodes 16 on a patient's scalp. A recurved headset frame 14 ensures the proper angle between ear cups 26 as well as providing a convenient ability to position the headset with a supine subject at the brow of the subject. Flex circuitry incorporates networked electrodes within an economical assembly. The contact points of the headset 10 may advantageously include fluid-filled bladders that provide comfort, a good seal for excluding noise from ear cups 26, and uniform impedance at electrodes 16. A digital control box 41 contains a microprocessor, battery, and a patient ID system (e.g., barcode or RFID scanner) in order to perform the auditory testing conveniently in a clinical setting. Samples are taken from each electrode 16, 16', 16'' at an appropriate data rate for the appropriate frequency and duration to reduce data storage file size. Automatic detection of artifacts causes replay of affected epochs to avoid failed tests. Different audio tests (e.g., audiometry, mismatched negativity, equal probability) are supported by a PC-based programming system that connects to a web-based database for downloading/modifying testing protocol configurations for loading onto a headset. A particularly advantageous protocol is supported by randomizing stimulus sequences, which is used when presenting multiple stimuli when each needs to be repeated an equal number of times in random order. Data integrity is maintained by performing artifact detection and resting threshold monitoring before initiating stimulus based upon the slope of the resting brainwaves.

[0074] By virtue of the foregoing, an easy to use headset 10 allows testing one or more subjects even when not conveniently near to outlet power or data network access points. Training of clinician personal is simplified by having protocols automatically set up as well as built-in hardware and data integrity tests.

[0075] While the present invention has been illustrated by description of several embodiments and while the illustrative embodiments have been described in considerable detail, it is not the intention of the applicant to restrict or in any way limit the scope of the appended claims to such detail. Additional advantages and modifications may readily appear to those skilled in the art.

[0076] For example, although a headset 10 and distributed dyslexia screening test system 70 have been illustrated that have certain advantages, all of the functionality may be incorporated into a headset. Alternatively, a disposable headset may be used with most of the active components and processing connected thereto. As yet a further alternative, a general-purpose computer may be configured to perform the testing protocol and/or the waveform analysis with the headset including essentially only electrodes and speakers.

[0077] As another example, although screening of infants is advantageously emphasized herein, older children and adults may be advantageously tested as well.

[0078] As yet an additional example, although dyslexia is a condition discussed herein, it will be appreciated that other neurological conditions may advantageously be tested by a similar headset with a frame positioning electrodes in a desired position and configuration. Examples include autism, hearing loss, schizophrenia, etc.

What is claimed is:

1. A screening device, comprising:

a frame shaped to be engageable to a head between a reference location, at least one ear and a signal detection location;

a reference electrode attached to the frame at the reference location;

a signal electrode attached to the frame at the auditory processing location;

an auditory signal producer positioned by the frame over the ear; and

an auditory evoked response (AER) data processor operably configured to initiate an auditory signal from the auditory signal producer and to perform a signal processing operation on an AER signal sensed across the reference and signal electrodes.

2. The screening device of claim 1, further comprising a cantilevered flexible arm connecting the signal electrode to the frame.

3. The screening device of claim 1, further comprising a second signal electrode attached to the frame.

4. The screening device of claim 3, further comprising a multiplexing channel controlled by the AER data processor for selectively sampling the first and second signal electrodes.

5. The screening device of claim 3, wherein the AER data processor is further operatively configured to sample the first

signal electrode at a low frequency sampling rate and to sample the second signal electrode at a high frequency.

6. The screening device of claim 5, further comprising a multiplexing channel controlled by the AER data processor for selectively sampling the first and second signal electrodes.

7. The screening device of claim 3, further comprising a flexible printed circuit harness containing the electrodes and communication paths to the AER data processor and shaped for conforming to the head under the resilient urging of the frame.

8. The screening device of claim 1, further comprising a test subject identification device, the AER data processor further operably configured to associate a test subject identification with the AER signal.

9. The screening device of claim 8, wherein the test subject identification device comprises a barcode scanner.

10. The screening device of claim 8, wherein the test subject identification device comprises a radio frequency identification scanner.

11. The screening device of claim 1, further comprising a diagnostic analyzer operably configured to characterize the AER signal and to compare the characteristics to a predetermined dyslexic AER characteristic.

12. The screening device of claim 11, further comprising a communication link, wherein the diagnostic analyzer is coupled to the frame via the communication link.

13. The screening device of claim 1, wherein the AER data processor comprises a control module integral to the frame.

14. The screening device of claim 1, wherein the frame includes a disposable portion that includes the electrodes.

15. The screening device of claim 1, wherein the AER data processor includes digital storage configured to store the AER data.

16. The screening device of claim 1, wherein the AER data processor is further operably configured to perform a sequence of screening tests, and to store in the digital storage AER data associated with each test.

17. The screening device of claim 16, wherein the digital storage further includes a predetermined test protocol.

18. The screening device of claim 1, wherein the AER data processor is further operably configured to generate a user indication of a test condition.

19. The screening device of claim 1, wherein the frame is operably shaped to connect between the ears across a front portion of a patient's head.

20. The screening device of claim 1, wherein the frame comprises a recurved frame and a pair of ear cups attached to each end thereof.

21. The screening device of claim 1, wherein the frame comprises an ear cup having a resilient portion inwardly affixed thereto.

22. The screening device of claim 1, wherein the frame further comprises an ear cup having an electrode registered caudad to the sylvan fissure of a subject.

23. A method of performing auditory evoked response (AER), comprising:

positioning a device on the head of a subject, the device positioning a sound producer, a reference electrode and a signal electrode;

generating an auditory stimulus;

recording AER data across the reference and signal electrodes.

24. The method of claim 23, wherein recording the AER data further comprises:

storing the AER data on the device;

connecting the device to a data analyzer;

transmitting the stored AER data to the data analyzer.

25. The method of claim 23, wherein positioning the device on the head of the subject further comprising positioning the subject face up and positioning the device across a forward portion of the subject's head.

26. The method of claim 23, wherein generating the auditory stimulus further comprises:

in response to determining the sensed electrode voltage exceeding a threshold, imposing a sampling delay in pursuit of a resting brain state.

27. The method of claim 23, wherein generating the auditory stimulus further comprises:

detecting a resting brain wave; and

initiating the auditory stimulus at a predetermined slope of the resting brain wave.

28. The method of claim 23, further comprising:

in response to determining the AER data to contain an artifact, imposing a sampling delay and repeating an epoch of auditory stimulus and sampling AER data.

29. The method of claim 23, further comprising:

accessing a remotely stored auditory testing protocol into the device; and

disconnecting the device prior to positioning a device on the head of the subject.

30. The method of claim 23, wherein the device positions the reference electrode, low frequency signal electrode and a high frequency signal electrode, the method further comprising sampling the low frequency signal electrode at first sampling rate and sampling the high frequency signal electrode at a higher second sampling rate.

31. The method of claim 23, wherein the device positions the reference electrode, a first signal electrode and a second signal electrode, and whereinsampling the first and second frequency signal electrodes further comprises for each electrode:

sensing an EEG voltage;

converting the sensed voltage to a digital value;

sampling the digital value at a predetermined sampling rate over a multiplexing channel; and

recording the multiplexed digital data.

32. The method of claim 31, wherein sampling the digital value at a predetermined sampling rate over the multiplexing channel comprises further comprises sampling the first signal electrode at low frequency and sampling the second signal electrode at a high frequency.

* * * * *

专利名称(译)	用于自动化的方法和系统。听觉诱发反应系统		
公开(公告)号	US20070106169A1	公开(公告)日	2007-05-10
申请号	US10/561572	申请日	2004-06-18
[标]申请(专利权)人(译)	FADEM KALFORDÇ		
申请(专利权)人(译)	FADEM KALFORDÇ		
当前申请(专利权)人(译)	NEURONETRIX SOLUTIONS , LLC		
[标]发明人	FADEM KALFORD C		
发明人	FADEM, KALFORD C.		
IPC分类号	A61B5/04 A61B5/00 A61B5/0484		
CPC分类号	A61B5/04845 A61B5/04012 A61B5/0478 A61B5/048		
优先权	60/479684 2003-06-19 US 60/557230 2004-03-29 US		
外部链接	Espacenet USPTO		

摘要(译)

适用于临床的阅读障碍筛查测试系统包括集成耳机，其通过将电极定位在受试者的耳朵周围而有效且方便地执行听觉诱发反应（AER）测试。集成控制模块自动执行测试，为临床医生提供简化的控制和指示。定期上传存储在耳机中的许多筛选测试以进行计费，远程分析和结果报告。

