



US008983564B2

(12) **United States Patent**  
**Al-Ali**

(10) **Patent No.:** **US 8,983,564 B2**  
(45) **Date of Patent:** **Mar. 17, 2015**

(54) **PERFUSION INDEX SMOOTHER**  
(71) Applicant: **Masimo Corporation**, Irvine, CA (US)  
(72) Inventor: **Ammar Al-Ali**, San Juan Capistrano, CA (US)  
(73) Assignee: **Masimo Corporation**, Irvine, CA (US)  
(\* ) Notice: Subject to any disclaimer, the term of this patent is extended or adjusted under 35 U.S.C. 154(b) by 0 days.  
(21) Appl. No.: **13/627,855**

(56) **References Cited**  
U.S. PATENT DOCUMENTS  
4,960,128 A 10/1990 Gordon et al.  
4,964,408 A 10/1990 Hink et al.  
5,041,187 A 8/1991 Hink et al.  
5,069,213 A 12/1991 Polczynski  
5,163,438 A 11/1992 Gordon et al.  
5,319,355 A 6/1994 Russek  
5,337,744 A 8/1994 Branigan  
5,341,805 A 8/1994 Stavridi et al.  
D353,195 S 12/1994 Savage et al.  
D353,196 S 12/1994 Savage et al.  
5,377,676 A 1/1995 Vari et al.  
(Continued)

(22) Filed: **Sep. 26, 2012**  
(65) **Prior Publication Data**  
US 2013/0079610 A1 Mar. 28, 2013

FOREIGN PATENT DOCUMENTS  
WO WO 2004/034898 4/2004  
WO WO 2006/097866 9/2006

**Related U.S. Application Data**  
(63) Continuation of application No. 11/871,620, filed on Oct. 12, 2007, now Pat. No. 8,280,473.  
(60) Provisional application No. 60/851,346, filed on Oct. 12, 2006.

OTHER PUBLICATIONS  
Office Action for European Appl. No. 07852700.9, dated Apr. 12, 2012, in 4 pages.  
(Continued)

(51) **Int. Cl.**  
**A61B 5/1455** (2006.01)  
**A61B 5/0295** (2006.01)  
**A61B 5/026** (2006.01)  
**A61B 5/0205** (2006.01)  
**A61B 5/00** (2006.01)  
(52) **U.S. Cl.**  
CPC ..... **A61B 5/0295** (2013.01); **A61B 5/0261** (2013.01); **A61B 5/14551** (2013.01); **A61B 5/0205** (2013.01); **A61B 5/7278** (2013.01); **A61B 5/7207** (2013.01)  
USPC ..... **600/310**; **600/322**; **600/324**  
(58) **Field of Classification Search**  
USPC ..... **600/310-344**  
See application file for complete search history.

*Primary Examiner* — Eric Winakur  
*Assistant Examiner* — Marjan Fardanesh  
(74) *Attorney, Agent, or Firm* — Knobbe Martens Olson & Bear LLP

(57) **ABSTRACT**  
An embodiment of the present disclosure seeks to smooth a perfusion index measurement through use of a baseline perfusion index measurement and/or through the use of multiple PI calculations. The combination of the baseline perfusion index measurement reduces an error between a calculated measurement of PI and actual conditions.

**4 Claims, 7 Drawing Sheets**

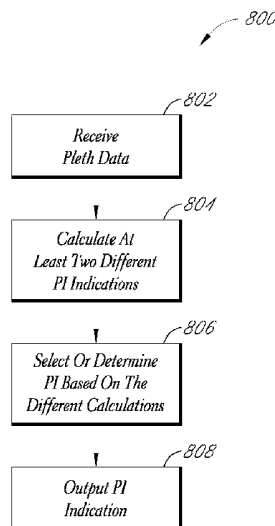

(56)

## References Cited

## U.S. PATENT DOCUMENTS

D359,546	S	6/1995	Savage et al.	6,325,761	B1	12/2001	Jay
5,431,170	A	7/1995	Mathews	6,334,065	B1	12/2001	Al-Ali et al.
D361,840	S	8/1995	Savage et al.	6,343,224	B1	1/2002	Parker
D362,063	S	9/1995	Savage et al.	6,349,228	B1	2/2002	Kiani et al.
5,452,717	A	9/1995	Branigan et al.	6,360,114	B1	3/2002	Diab et al.
D363,120	S	10/1995	Savage et al.	6,368,283	B1	4/2002	Xu et al.
5,456,252	A	10/1995	Vari et al.	6,371,921	B1	4/2002	Caro et al.
5,479,934	A	1/1996	Imran	6,377,829	B1	4/2002	Al-Ali
5,482,036	A	1/1996	Diab et al.	6,388,240	B2	5/2002	Schulz et al.
5,490,505	A	2/1996	Diab et al.	6,397,091	B2	5/2002	Diab et al.
5,494,043	A	2/1996	O'Sullivan et al.	6,430,437	B1	8/2002	Marro
5,533,511	A	7/1996	Kaspari et al.	6,430,525	B1	8/2002	Weber et al.
5,534,851	A	7/1996	Russek	6,463,311	B1	10/2002	Diab
5,561,275	A	10/1996	Savage et al.	6,470,199	B1	10/2002	Kopotic et al.
5,562,002	A	10/1996	Lalin	6,501,975	B2	12/2002	Diab et al.
5,590,649	A	1/1997	Caro et al.	6,505,059	B1	1/2003	Kollias et al.
5,602,924	A	2/1997	Durand et al.	6,515,273	B2	2/2003	Al-Ali
5,632,272	A	5/1997	Diab et al.	6,519,487	B1	2/2003	Parker
5,638,816	A	6/1997	Kiani-Azarbayjany et al.	6,525,386	B1	2/2003	Mills et al.
5,638,818	A	6/1997	Diab et al.	6,526,300	B1	2/2003	Kiani et al.
5,645,440	A	7/1997	Tobler et al.	6,541,756	B2	4/2003	Schulz et al.
5,685,299	A	11/1997	Diab et al.	6,542,764	B1	4/2003	Al-Ali et al.
D393,830	S	4/1998	Tobler et al.	6,580,086	B1	6/2003	Schulz et al.
5,743,262	A	4/1998	Lepper, Jr. et al.	6,584,336	B1	6/2003	Ali et al.
5,758,644	A	6/1998	Diab et al.	6,595,316	B2	7/2003	Cybulski et al.
5,760,910	A	6/1998	Lepper, Jr. et al.	6,597,932	B2	7/2003	Tian et al.
5,766,127	A	* 6/1998	Pologe et al. .... 600/310	6,597,933	B2	7/2003	Kiani et al.
5,769,785	A	6/1998	Diab et al.	6,606,511	B1	8/2003	Ali et al.
5,782,757	A	7/1998	Diab et al.	6,632,181	B2	10/2003	Flaherty et al.
5,785,659	A	7/1998	Caro et al.	6,639,668	B1	10/2003	Trepagnier
5,791,347	A	8/1998	Flaherty et al.	6,640,116	B2	10/2003	Diab
5,810,734	A	9/1998	Caro et al.	6,643,530	B2	11/2003	Diab et al.
5,823,950	A	10/1998	Diab et al.	6,650,917	B2	11/2003	Diab et al.
5,830,131	A	11/1998	Caro et al.	6,654,624	B2	11/2003	Diab et al.
5,833,618	A	11/1998	Caro et al.	6,658,276	B2	12/2003	Pishney et al.
5,860,919	A	1/1999	Kiani-Azarbayjany et al.	6,661,161	B1	12/2003	Lanzo et al.
5,890,929	A	4/1999	Mills et al.	6,671,531	B2	12/2003	Al-Ali et al.
5,904,654	A	5/1999	Wohlmann et al.	6,678,543	B2	1/2004	Diab et al.
5,919,134	A	7/1999	Diab	6,684,090	B2	1/2004	Ali et al.
5,934,925	A	8/1999	Tobler et al.	6,684,091	B2	1/2004	Parker
5,940,182	A	8/1999	Lepper, Jr. et al.	6,697,656	B1	2/2004	Al-Ali
5,995,855	A	11/1999	Kiani et al.	6,697,657	B1	2/2004	Shehada et al.
5,997,343	A	12/1999	Mills et al.	6,697,658	B2	2/2004	Al-Ali
6,002,952	A	12/1999	Diab et al.	RE38,476	E	3/2004	Diab et al.
6,011,986	A	1/2000	Diab et al.	6,699,194	B1	3/2004	Diab et al.
6,027,452	A	2/2000	Flaherty et al.	6,714,804	B2	3/2004	Al-Ali et al.
6,036,642	A	3/2000	Diab et al.	RE38,492	E	4/2004	Diab et al.
6,045,509	A	4/2000	Caro et al.	6,721,582	B2	4/2004	Trepagnier et al.
6,067,462	A	5/2000	Diab et al.	6,721,585	B1	4/2004	Parker
6,081,735	A	6/2000	Diab et al.	6,725,075	B2	4/2004	Al-Ali
6,088,607	A	7/2000	Diab et al.	6,728,560	B2	4/2004	Kollias et al.
6,110,522	A	8/2000	Lepper, Jr. et al.	6,735,459	B2	5/2004	Parker
6,124,597	A	9/2000	Shehada et al.	6,745,060	B2	6/2004	Diab et al.
6,128,521	A	10/2000	Marro et al.	6,760,607	B2	7/2004	Al-Ali
6,129,675	A	10/2000	Jay	6,770,028	B1	8/2004	Ali et al.
6,144,868	A	11/2000	Parker	6,771,994	B2	8/2004	Kiani et al.
6,151,516	A	11/2000	Kiani-Azarbayjany et al.	6,792,300	B1	9/2004	Diab et al.
6,152,754	A	11/2000	Gerhardt et al.	6,813,511	B2	11/2004	Diab et al.
6,157,850	A	12/2000	Diab et al.	6,816,741	B2	11/2004	Diab
6,165,005	A	12/2000	Mills et al.	6,822,564	B2	11/2004	Al-Ali
6,184,521	B1	2/2001	Coffin, IV et al.	6,826,419	B2	11/2004	Diab et al.
6,206,830	B1	3/2001	Diab et al.	6,830,711	B2	12/2004	Mills et al.
6,229,856	B1	5/2001	Diab et al.	6,850,787	B2	2/2005	Weber et al.
6,232,609	B1	5/2001	Snyder et al.	6,850,788	B2	2/2005	Al-Ali
6,236,872	B1	5/2001	Diab et al.	6,852,083	B2	2/2005	Caro et al.
6,241,683	B1	6/2001	Macklem et al.	6,861,639	B2	3/2005	Al-Ali
6,253,097	B1	6/2001	Aronow et al.	6,898,452	B2	5/2005	Al-Ali et al.
6,256,523	B1	7/2001	Diab et al.	6,920,345	B2	7/2005	Al-Ali et al.
6,263,222	B1	7/2001	Diab et al.	6,931,268	B1	8/2005	Kiani-Azarbayjany et al.
6,278,522	B1	8/2001	Lepper, Jr. et al.	6,934,570	B2	8/2005	Kiani et al.
6,280,213	B1	8/2001	Tobler et al.	6,939,305	B2	9/2005	Flaherty et al.
6,285,896	B1	9/2001	Tobler et al.	6,943,348	B1	9/2005	Coffin IV
6,301,493	B1	10/2001	Marro et al.	6,950,687	B2	9/2005	Al-Ali
6,317,627	B1	11/2001	Ennen et al.	6,961,598	B2	11/2005	Diab
6,321,100	B1	11/2001	Parker	6,970,792	B1	11/2005	Diab
				6,979,812	B2	12/2005	Al-Ali
				6,985,764	B2	1/2006	Mason et al.
				6,993,371	B2	1/2006	Kiani et al.
				6,996,427	B2	2/2006	Ali et al.

(56)

## References Cited

## U.S. PATENT DOCUMENTS

6,999,904	B2	2/2006	Weber et al.	7,530,949	B2	5/2009	Al Ali et al.
7,003,338	B2	2/2006	Weber et al.	7,530,955	B2	5/2009	Diab et al.
7,003,339	B2	2/2006	Diab et al.	7,563,110	B2	7/2009	Al-Ali et al.
7,015,451	B2	3/2006	Dalke et al.	7,596,398	B2	9/2009	Al-Ali et al.
7,024,233	B2	4/2006	Ali et al.	7,618,375	B2	11/2009	Flaherty et al.
7,027,849	B2	4/2006	Al-Ali	D606,659	S	12/2009	Kiani et al.
7,030,749	B2	4/2006	Al-Ali	7,647,083	B2	1/2010	Al-Ali et al.
7,039,449	B2	5/2006	Al-Ali	D609,193	S	2/2010	Al-Ali et al.
7,041,060	B2	5/2006	Flaherty et al.	D614,305	S	4/2010	Al-Ali et al.
7,044,918	B2	5/2006	Diab	RE41,317	E	5/2010	Parker
7,067,893	B2	6/2006	Mills et al.	7,729,733	B2	6/2010	Al-Ali et al.
7,096,052	B2	8/2006	Mason et al.	7,734,320	B2	6/2010	Al-Ali
7,096,054	B2	8/2006	Abdul-Hafiz et al.	7,761,127	B2	7/2010	Al-Ali et al.
7,132,641	B2	11/2006	Schulz et al.	7,761,128	B2	7/2010	Al-Ali et al.
7,142,901	B2	11/2006	Kiani et al.	7,764,982	B2	7/2010	Dalke et al.
7,149,561	B2	12/2006	Diab	D621,516	S	8/2010	Kiani et al.
7,186,966	B2	3/2007	Al-Ali	7,791,155	B2	9/2010	Diab
7,190,261	B2	3/2007	Al-Ali	7,801,581	B2	9/2010	Diab
7,215,984	B2	5/2007	Diab et al.	7,822,452	B2	10/2010	Schurman et al.
7,215,986	B2	5/2007	Diab et al.	RE41,912	E	11/2010	Parker
7,221,971	B2	5/2007	Diab et al.	7,844,313	B2	11/2010	Kiani et al.
7,225,006	B2	5/2007	Al-Ali et al.	7,844,314	B2	11/2010	Al-Ali
7,225,007	B2	5/2007	Al-Ali et al.	7,844,315	B2	11/2010	Al-Ali
RE39,672	E	6/2007	Shehada et al.	7,865,222	B2	1/2011	Weber et al.
7,239,905	B2	7/2007	Kiani-Azarbayjany et al.	7,873,497	B2	1/2011	Weber et al.
7,245,953	B1	7/2007	Parker	7,880,606	B2	2/2011	Al-Ali
7,254,429	B2	8/2007	Schurman et al.	7,880,626	B2	2/2011	Al-Ali et al.
7,254,431	B2	8/2007	Al-Ali et al.	7,891,355	B2	2/2011	Al-Ali et al.
7,254,433	B2	8/2007	Diab et al.	7,894,868	B2	2/2011	Al-Ali et al.
7,254,434	B2	8/2007	Schulz et al.	7,899,507	B2	3/2011	Al-Ali et al.
7,272,425	B2	9/2007	Al-Ali	7,899,518	B2	3/2011	Trepagnier et al.
7,274,955	B2	9/2007	Kiani et al.	7,904,132	B2	3/2011	Weber et al.
D554,263	S	10/2007	Al-Ali et al.	7,909,772	B2	3/2011	Popov et al.
7,280,858	B2	10/2007	Al-Ali et al.	7,910,875	B2	3/2011	Al-Ali
7,289,835	B2	10/2007	Mansfield et al.	7,919,713	B2	4/2011	Al-Ali et al.
7,292,883	B2	11/2007	De Felice et al.	7,937,128	B2	5/2011	Al-Ali
7,295,866	B2	11/2007	Al-Ali	7,937,129	B2	5/2011	Mason et al.
7,328,053	B1	2/2008	Diab et al.	7,937,130	B2	5/2011	Diab et al.
7,332,784	B2	2/2008	Mills et al.	7,941,199	B2	5/2011	Kiani
7,340,287	B2	3/2008	Mason et al.	7,951,086	B2	5/2011	Flaherty et al.
7,341,559	B2	3/2008	Schulz et al.	7,957,780	B2	6/2011	Lamego et al.
7,343,186	B2	3/2008	Lamego et al.	7,962,188	B2	6/2011	Kiani et al.
D566,282	S	4/2008	Al-Ali et al.	7,962,190	B1	6/2011	Diab et al.
7,355,512	B1	4/2008	Al-Ali	7,976,472	B2	7/2011	Kiani
7,356,365	B2	4/2008	Schurman	7,988,637	B2	8/2011	Diab
7,371,981	B2	5/2008	Abdul-Hafiz	7,990,382	B2	8/2011	Kiani
7,373,193	B2	5/2008	Al-Ali et al.	7,991,446	B2	8/2011	Ali et al.
7,373,194	B2	5/2008	Weber et al.	8,000,761	B2	8/2011	Al-Ali
7,376,453	B1	5/2008	Diab et al.	8,008,088	B2	8/2011	Bellott et al.
7,377,794	B2	5/2008	Al-Ali et al.	RE42,753	E	9/2011	Kiani-Azarbayjany et al.
7,377,899	B2	5/2008	Weber et al.	8,019,400	B2	9/2011	Diab et al.
7,383,070	B2	6/2008	Diab et al.	8,028,701	B2	10/2011	Al-Ali et al.
7,415,297	B2	8/2008	Al-Ali et al.	8,029,765	B2	10/2011	Bellott et al.
7,428,432	B2	9/2008	Ali et al.	8,036,728	B2	10/2011	Diab et al.
7,438,683	B2	10/2008	Al-Ali et al.	8,046,040	B2	10/2011	Ali et al.
7,440,787	B2	10/2008	Diab	8,046,041	B2	10/2011	Diab et al.
7,454,240	B2	11/2008	Diab et al.	8,046,042	B2	10/2011	Diab et al.
7,467,002	B2	12/2008	Weber et al.	8,048,040	B2	11/2011	Kiani
7,469,157	B2	12/2008	Diab et al.	8,050,728	B2	11/2011	Al-Ali et al.
7,471,969	B2	12/2008	Diab et al.	RE43,169	E	2/2012	Parker
7,471,971	B2	12/2008	Diab et al.	8,118,620	B2	2/2012	Al-Ali et al.
7,483,729	B2	1/2009	Al-Ali et al.	8,126,528	B2	2/2012	Diab et al.
7,483,730	B2	1/2009	Diab et al.	8,128,572	B2	3/2012	Diab et al.
7,489,958	B2	2/2009	Diab et al.	8,130,105	B2	3/2012	Al-Ali et al.
7,496,391	B2	2/2009	Diab et al.	8,145,287	B2	3/2012	Diab et al.
7,496,393	B2	2/2009	Diab et al.	8,150,487	B2	4/2012	Diab et al.
D587,657	S	3/2009	Al-Ali et al.	8,175,672	B2	5/2012	Parker
7,499,741	B2	3/2009	Diab et al.	8,180,420	B2	5/2012	Diab et al.
7,499,835	B2	3/2009	Weber et al.	8,182,443	B1	5/2012	Kiani
7,500,950	B2	3/2009	Al-Ali et al.	8,185,180	B2	5/2012	Diab et al.
7,509,154	B2	3/2009	Diab et al.	8,190,223	B2	5/2012	Al-Ali et al.
7,509,494	B2	3/2009	Al-Ali	8,190,227	B2	5/2012	Diab et al.
7,510,849	B2	3/2009	Schurman et al.	8,203,438	B2	6/2012	Kiani et al.
7,526,328	B2	4/2009	Diab et al.	8,224,411	B2	7/2012	Al-Ali et al.
7,530,942	B1	5/2009	Diab	8,228,181	B2	7/2012	Al-Ali
				8,229,533	B2	7/2012	Diab et al.
				8,255,026	B1	8/2012	Al-Ali
				8,255,028	B2	8/2012	Al-Ali et al.
				8,260,577	B2	9/2012	Weber et al.

(56)

**References Cited**

U.S. PATENT DOCUMENTS

8,274,360 B2 9/2012 Sampath et al.  
 8,301,217 B2 10/2012 Al-Ali et al.  
 8,310,336 B2 11/2012 Muhsin et al.  
 8,315,683 B2 11/2012 Al-Ali et al.  
 RE43,860 E 12/2012 Parker  
 8,337,403 B2 12/2012 Al-Ali et al.  
 8,346,330 B2 1/2013 Lamego  
 8,353,842 B2 1/2013 Al-Ali et al.  
 8,355,766 B2 1/2013 MacNeish, III et al.  
 8,359,080 B2 1/2013 Diab et al.  
 8,364,223 B2 1/2013 Al-Ali et al.  
 8,364,226 B2 1/2013 Diab et al.  
 8,374,665 B2 2/2013 Lamego  
 8,385,995 B2 2/2013 Al-Ali et al.  
 8,385,996 B2 2/2013 Smith et al.  
 8,388,353 B2 3/2013 Kiani et al.  
 8,399,822 B2 3/2013 Al-Ali  
 8,401,602 B2 3/2013 Kiani  
 8,405,608 B2 3/2013 Al-Ali et al.  
 8,414,499 B2 4/2013 Al-Ali et al.  
 8,418,524 B2 4/2013 Al-Ali  
 8,423,106 B2 4/2013 Lamego et al.  
 8,428,967 B2 4/2013 Olsen et al.  
 8,430,817 B1 4/2013 Al-Ali et al.  
 8,437,825 B2 5/2013 Dalvi et al.  
 8,455,290 B2 6/2013 Siskavich  
 8,457,703 B2 6/2013 Al-Ali

8,457,707 B2 6/2013 Kiani  
 8,463,349 B2 6/2013 Diab et al.  
 8,466,286 B2 6/2013 Bellott et al.  
 8,471,713 B2 6/2013 Poeze et al.  
 8,473,020 B2 6/2013 Kiani et al.  
 8,483,787 B2 7/2013 Al-Ali et al.  
 8,489,364 B2 7/2013 Weber et al.  
 8,498,684 B2 7/2013 Weber et al.  
 8,509,867 B2 8/2013 Workman et al.  
 8,515,509 B2 8/2013 Bruinsma et al.  
 8,523,781 B2 9/2013 Al-Ali  
 8,529,301 B2 9/2013 Al-Ali et al.  
 8,532,727 B2 9/2013 Ali et al.  
 8,532,728 B2 9/2013 Diab et al.  
 D692,145 S 10/2013 Al-Ali et al.  
 8,547,209 B2 10/2013 Kiani et al.  
 8,548,548 B2 10/2013 Al-Ali  
 8,548,550 B2 10/2013 Al-Ali et al.  
 8,560,032 B2 10/2013 Al-Ali et al.  
 8,560,034 B1 10/2013 Diab et al.  
 2003/0163032 A1\* 8/2003 Terry ..... 600/322  
 2006/0167362 A1 7/2006 Neumann et al.

OTHER PUBLICATIONS

Office Action for European Appl. No. 07852700.9, dated Aug. 10, 2012, in 7 pages.

PCT Communication Relating to the Results of the International Search for PCT/US2007/021816, dated Dec. 4, 2008, in 23 pages.

\* cited by examiner

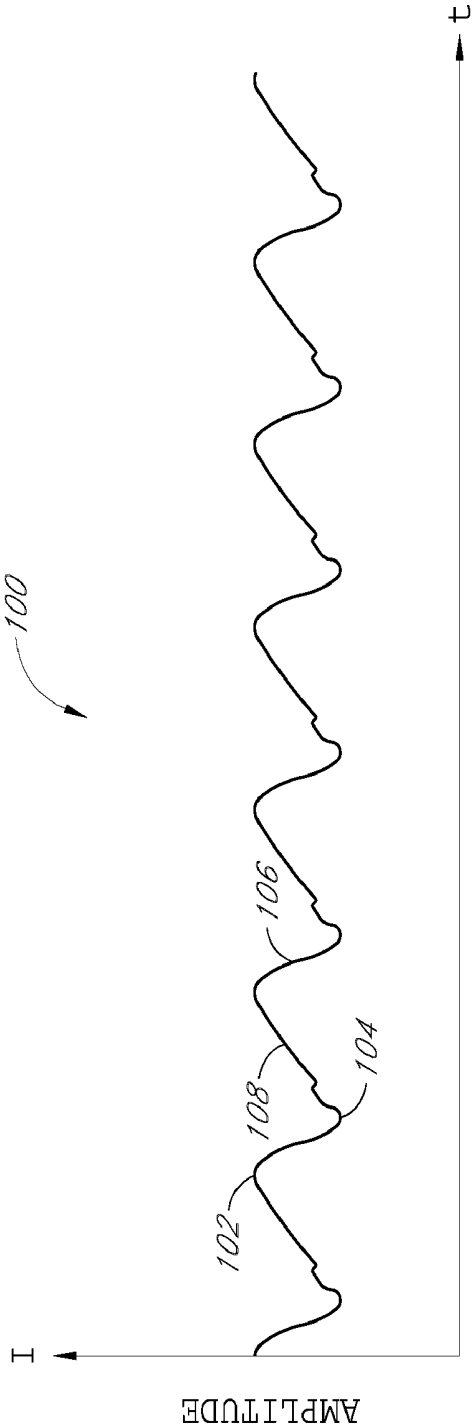

FIG. 1

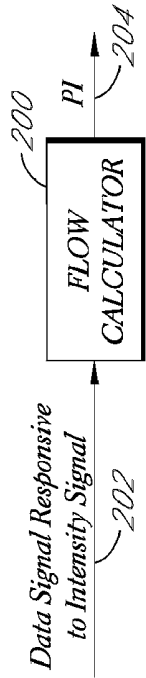

FIG. 2

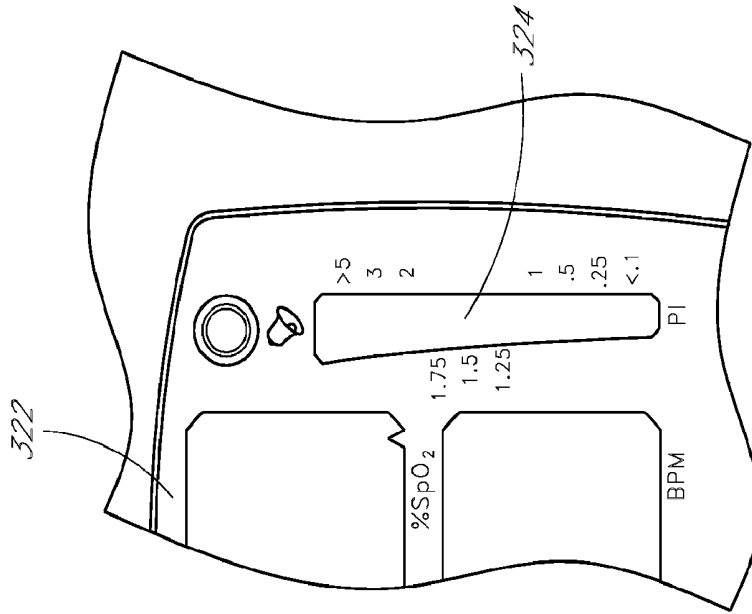

FIG. 3B

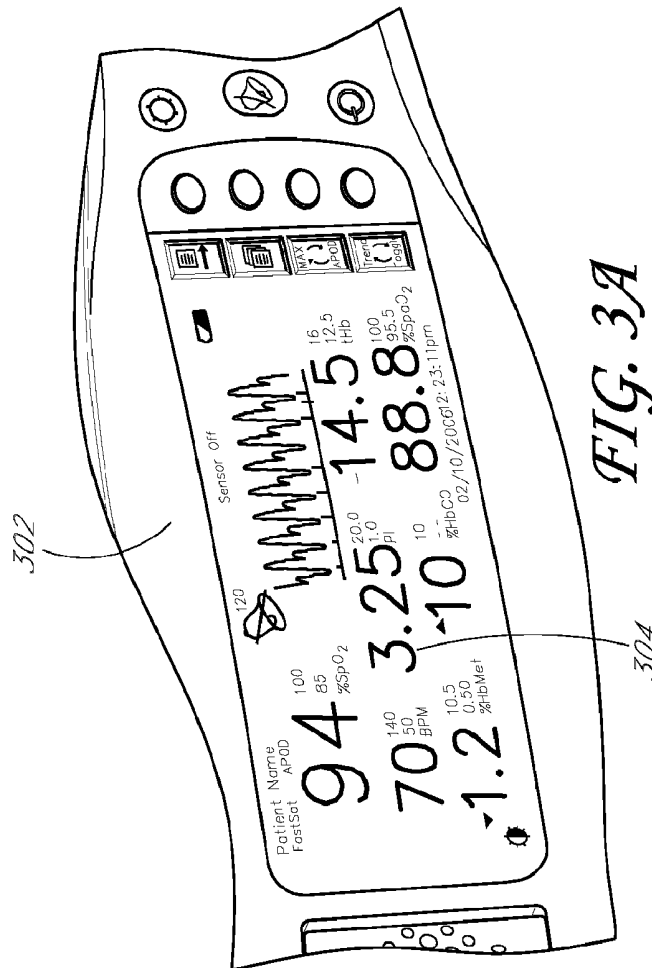

FIG. 3A

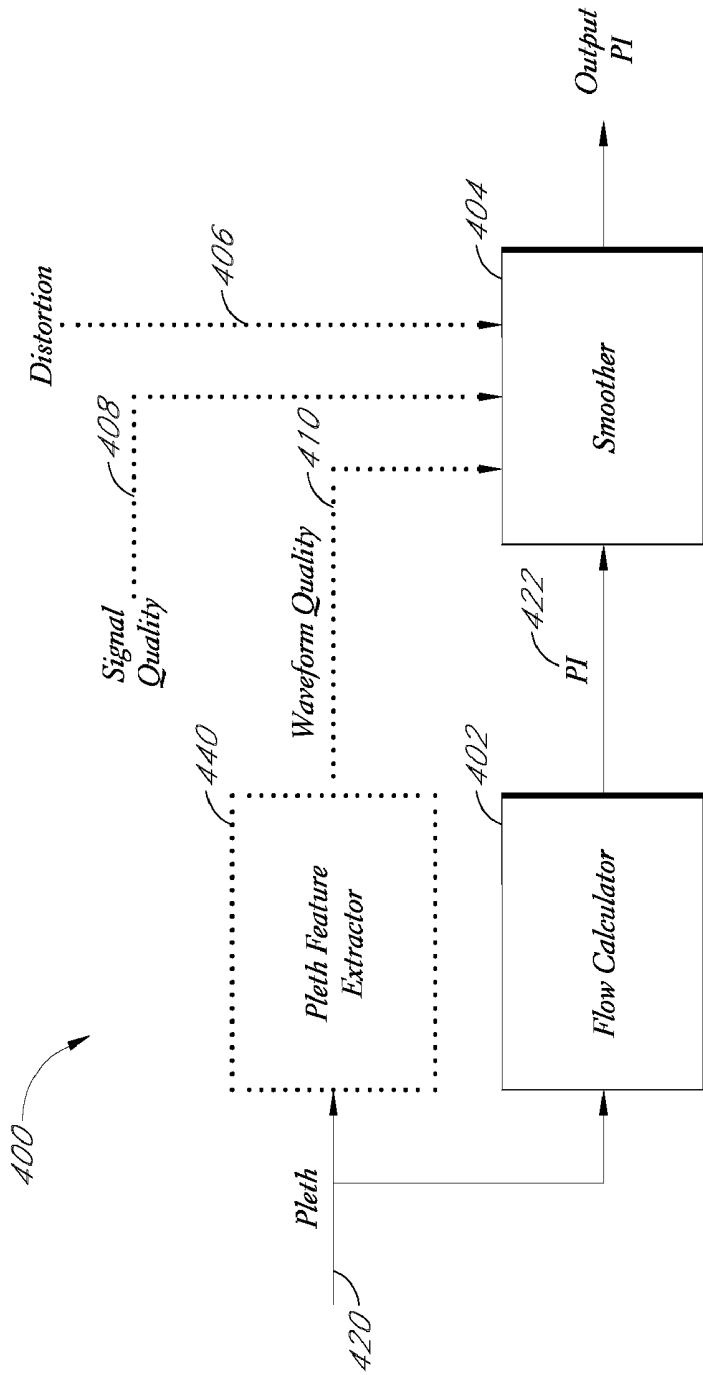

FIG. 4

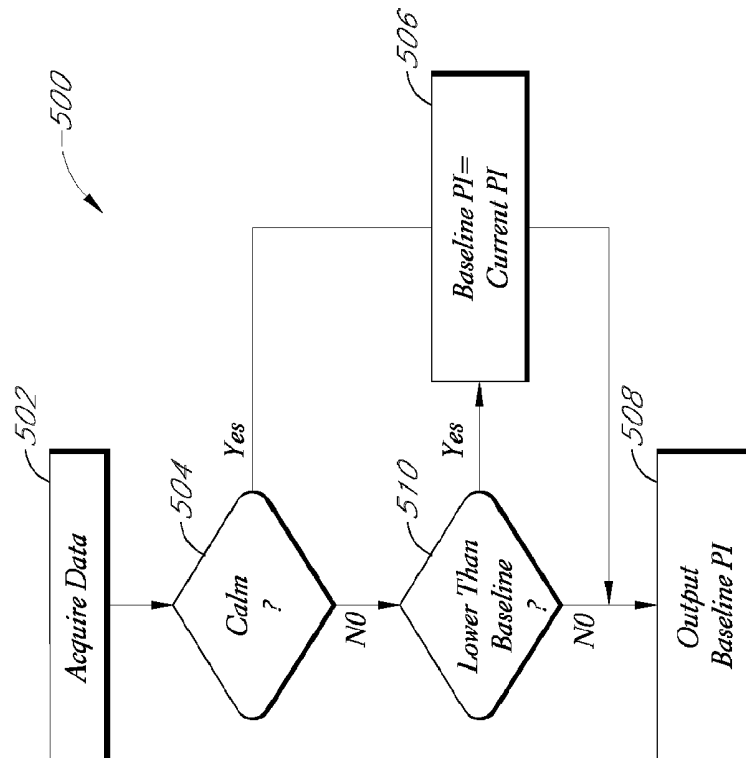

FIG. 5



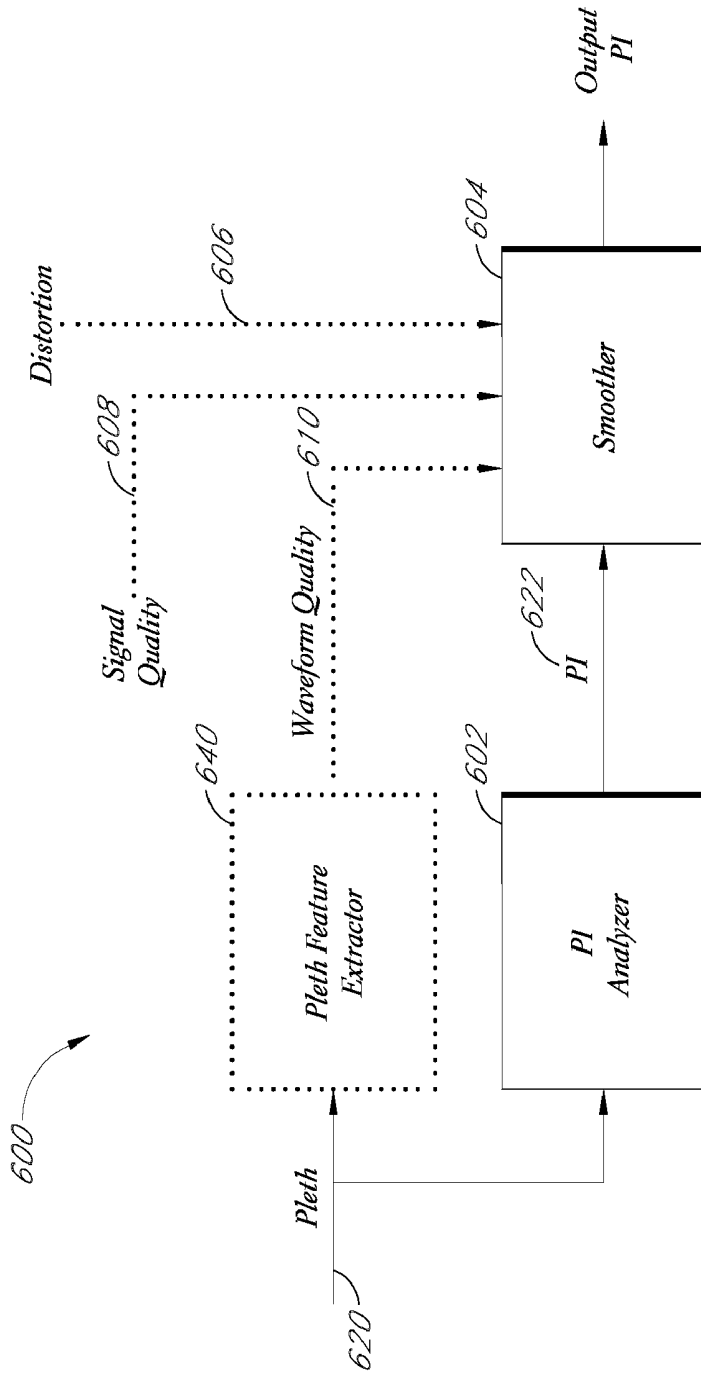

FIG. 6

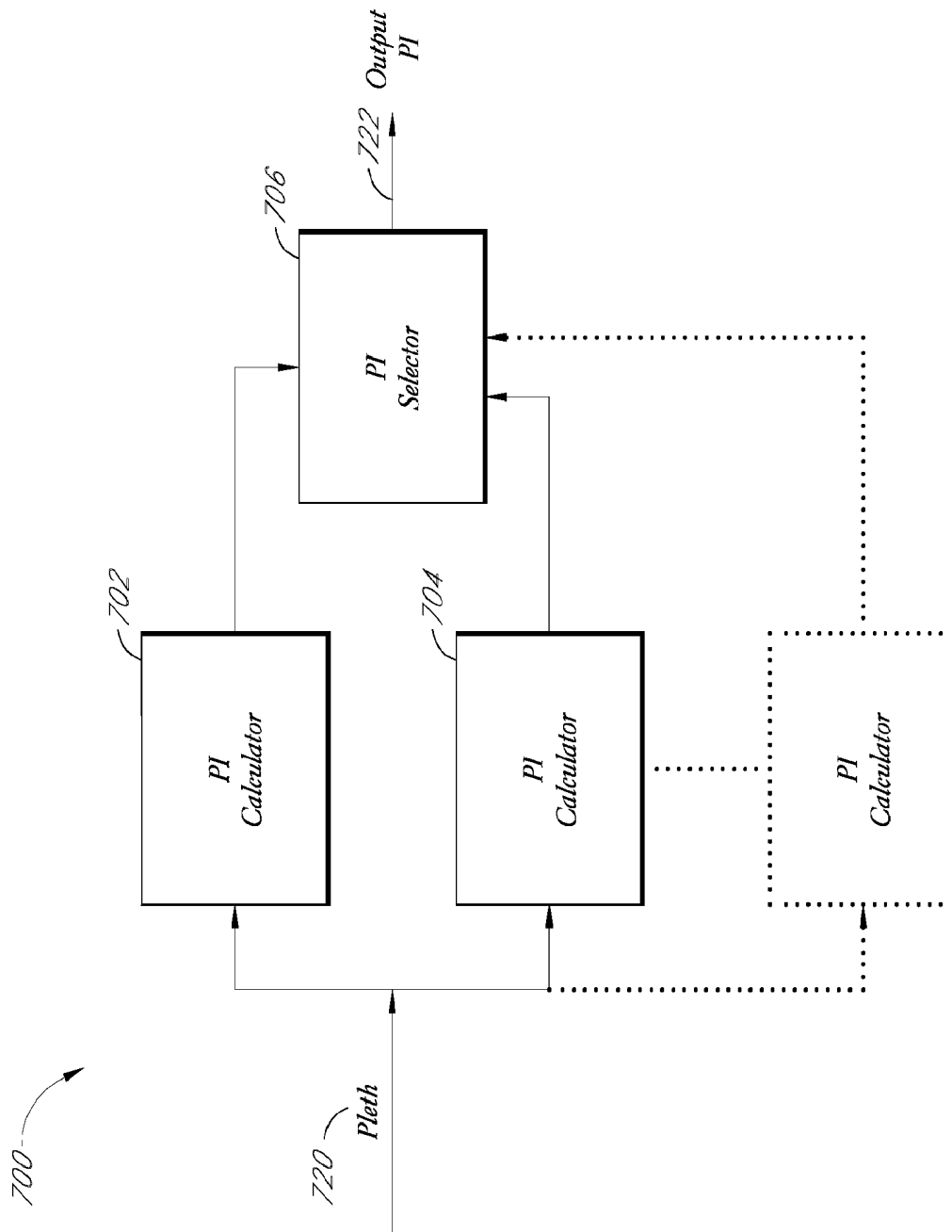

FIG. 7

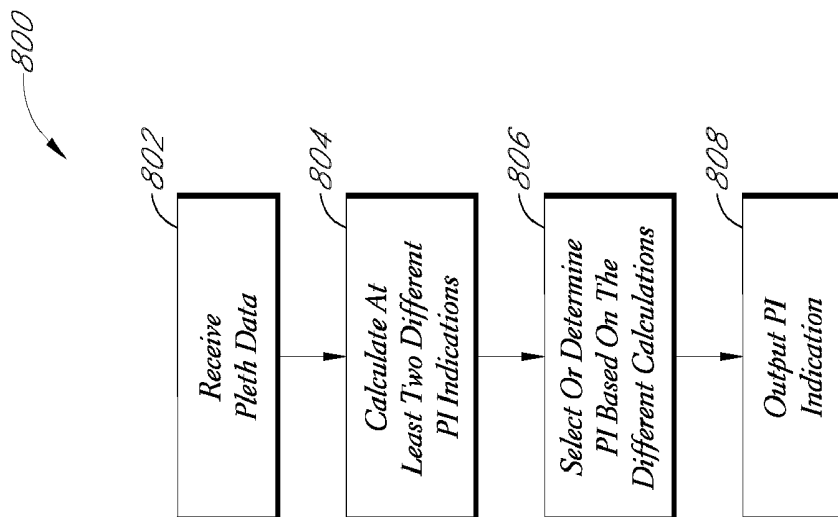

FIG. 8

## PERFUSION INDEX SMOOTHER

## PRIORITY CLAIM TO RELATED PROVISIONAL APPLICATIONS

The present application is a continuation of U.S. application Ser. No. 11/871,620, filed Oct. 12, 2007, entitled "Perfusion Index Smoother," which claims priority benefit under 35 U.S.C. §119(e) of U.S. Provisional Application Ser. No. 60/851,346, filed Oct. 12, 2006, entitled "Perfusion Index Smoother," which is incorporated herein by reference.

## RELATED CASES

The present application is related to U.S. Pat. Nos. 6,334,065, 6,606,511 and the continuation, continuation-in-part, and divisional applications thereof. The foregoing disclosure is incorporated herein by reference and included in the present filing.

## BACKGROUND OF THE DISCLOSURE

## 1. Field of the Disclosure

The present disclosure relates in general to patient monitoring and in particular to oximeter patient monitors capable of determining perfusion index measurements.

## 2. Description of the Related Art

Oximeter systems providing measurements of a monitored patient have become the standard of care in many patient care settings, including surgical, post surgical, neonatal, general ward, home care, physical training, and the like. In general, oximeter systems accept one or more noninvasive signals from an optical sensor or probe capable of emitting multiple wavelengths of light into a tissue site and capable of detecting light after attenuated by the tissue site. The optical sensor generally outputs intensity signal data. FIG. 1 illustrates a photoplethysmograph intensity signal **100** output by an oximeter sensor. An oximeter does not directly detect absorption, and hence does not directly measure a standard plethysmograph waveform. However, the standard plethysmograph can be derived by observing that the detected intensity signal **100** is merely an out of phase version of an absorption profile known to one of skill in the art. That is, the peak detected intensity **102**, generally corresponds to a minimum absorption, and minimum detected intensity **104**, generally corresponds to a maximum absorption. Further, a rapid rise in absorption during an inflow phase of the plethysmograph is reflected in a rapid decline **106** in intensity. Likewise, a gradual decline in absorption during the outflow phase of the plethysmograph is reflected in a gradual increase **108** in detected intensity.

FIG. 2 illustrates a flow calculator **200** which receives a processed signal **202** responsive to at least one of the intensity signals output from the sensor. In an embodiment, the flow calculator outputs an indication of blood flow, such as, for example, a perfusion index (PI) **204**. In an embodiment, the PI **204** comprises a relative indication of pulse strength at a monitoring site. For example, the PI **204** may be defined as the ratio of the wavelength's (A) AC signal to the DC signal, or the percentage of pulsatile signal to non-pulsatile signal, according to the following:

$$PI = (\lambda_{max} - \lambda_{min}) / \lambda_{DC}$$

where  $\lambda_{max}$  is the maximum value,  $\lambda_{min}$  is the minimum value, and  $\lambda_{DC}$  is the average value of the signal **202**.

Once calculated, the PI **204** may advantageously be displayed in a wide number of ways, including rising LEDs or

other display elements, text, graphics, or other visual elements including color, flashing, and the like, trended data, trace data, or the like. FIG. 3A illustrates a display output for an oximeter patient monitor **302** including a textual PI display **304** (shown as "3.25 PI") ranging from 1.0 to 20. FIG. 3B illustrates a display output for a handheld oximeter patient monitor **322** including a PI bar **324** ranging from, for example, "<0.1%" to ">5%" with steps of "<0.1%," "0.25%," "0.5%," "1%," "1.25%," "1.5%," "1.75%," "2%," "3%," and ">5%." An artisan will recognize from the disclosure herein that various steps and a wide variety of scalars or other mathematical mapping can be used to make PI numbers more readily understandable to a caregiver. However, using the foregoing scale, the PI bar **324** can be used as a diagnostic tool during low perfusion for the accurate prediction of illness severity, especially in neonates. Moreover, the rate of change in the PI bar **324** can be indicative of blood loss, sleep arousal, severe hypertension, pain management, the presence or absence of drugs, or the like. According to one embodiment, a measurement below about "1.25%" may indicate medical situations in need of caregiver attention, specifically in monitored neonates. Because of the relevance of about "1.25%", the PI bar **324** may advantageously include level indicia that switch sides of the PI bar **324**, thus highlighting any readings below about that threshold. Moreover, behavior of the PI bar **324**, as discussed below, may advantageously draw attention to monitored values below such a threshold.

The PI bar **324** may advantageously activate LEDs from a bottom toward a top such that the bar "fills" to a level proportional to the measured value. In one embodiment, the PI bar **324** shows a static value of perfusion for a given time period, such as, for example, one or more pulses. In another embodiment, or functional setting, the PI bar **324** may advantageously pulse with a pulse rate, may hold the last reading and optionally fade until the next reading, may indicate historical readings through colors or fades, traces or the like. Additionally, the PI bar **324** may advantageously change colors, flash, increasingly flash, or the like to indicate worsening measured values of perfusion.

As discussed above, the monitors **302**, **322** may include output functionality that outputs, for example, trend perfusion data, such that a caregiver can monitor measured values of perfusion over time. Alternatively or additionally, the monitors **302**, **322** may display historical trace data on an appropriate display indicating the measured values of perfusion over time. In an embodiment, the trend data is uploaded to an external computing device through, for example, a multipurpose sensor connector or other input output systems such as USB, serial or parallel ports, computing networks, or the like. Additional information regarding the calculation and use of PI is disclosed in the '065 patent, assigned to Masimo Corporation ("Masimo") of Irvine, Calif., and incorporated by reference herein.

## SUMMARY OF THE DISCLOSURE

Aspects of the present disclosure include a system which provides a more accurate indication of PI. In one embodiment, the wavelength used to determine PI is in the infrared (IR) spectrum. IR wavelengths are more independent of saturation than are wavelengths in the Red (R) spectrum. As a result, when the saturation changes, the PI calculated from a R wavelength tends to vary greater than the PI calculated from a IR wavelength. Although the IR intensity signal data is less responsive to saturation than various other intensity channels, the IR intensity signal remains somewhat susceptible to motion-induced noise, distortion and the like. In general, PI

measurements during lower signal quality or distortion generally trends the PI too high. As understood by an artisan from the disclosure herein, higher PI measurements should correlate to better perfusion through the tissue site, and lower PI measurements should correlate to lower perfusion through the tissue site. Thus, noise may cause a patient monitor to give a caregiver the indication that a patient has better perfusion through a measurement site than is actually the case.

Based at least thereon, embodiments of the present disclosure seek to reduce an error between a calculated measurement of PI and actual conditions. In an embodiment, a baseline perfusion index (“baseline PI”) is determined and used to improve measurements during motion conditions. For example, a smoother may advantageously determine a baseline PI during strong signal quality, high signal confidence conditions, and use that baseline PI or a statistical combination of baseline PIs instead of or in addition to the current PI that is being influenced by noise. In an embodiment, the smoother selects the lower PI value as the output PI value. This is because motion noise tends to increase PI, thus the lower PI value tends to be the more accurate value.

In an embodiment, PI is calculated using at least two different calculation techniques. The two different calculations are analyzed and a PI indication is determined. In an embodiment, the lower of the two PI values is chosen. In an embodiment, the PI values are averaged or statistically analyzed to determine a more accurate value for PI.

In an embodiment, a method of smoothing a perfusion index measurement in an oximeter system is disclosed. The method includes the steps of establishing a baseline perfusion index during quality signal conditions of a signal responsive to intensity signals acquired from a detector capable of detecting light attenuated by body tissue and leveraging the baseline perfusion index during poor signal conditions. In an embodiment, leveraging includes outputting the baseline perfusion index when a current perfusion index measurement is higher than the baseline perfusion index. In an embodiment, leveraging includes outputting a current perfusion index measurement when the baseline perfusion index is higher than the current perfusion index measurement. In an embodiment, the signal is responsive to an IR intensity signal.

In an embodiment, an oximeter is disclosed. The oximeter includes an input capable of receiving intensity signal data responsive to intensity signals acquired from a detector capable of detecting light attenuated by body tissue, a memory storing a baseline Perfusion Index (PI) and a processor programmed to output the baseline PI when the signal data includes motion-induced noise and a current PI derived from the signal data is not lower than the baseline PI. In an embodiment, an alarm is included which is configured to alert a caregiver when the output meets predetermined criteria. In an embodiment, the processor is programmed to output the current PI when the signal data is relatively calm or when the current PI is lower than the baseline PI.

In an embodiment, a method of determining an indication of perfusion index in a patient monitor is disclosed. The method includes the steps of receiving plethysmographic data, calculating two or more indications of perfusion index using at least two different calculation techniques, and determining a final indication of perfusion index based on the indications of perfusion index. In an embodiment, the final indication of perfusion index is determined by selecting the lowest indication of perfusion index. In an embodiment, the final indication of perfusion index is determined by statistical analysis. In an embodiment, the final indication of perfusion index is determined by averaging the indications of perfusion index.

In an embodiment, a method of determining an indication of perfusion index is disclosed. The method includes the steps of receiving plethysmographic data and determining an indication of perfusion index by utilizing at least one calculation techniques to determine a resulting indication of perfusion index. In an embodiment, determining the indication of perfusion index includes utilizing the calculation technique that will result in the lowest perfusion index value.

In an embodiment, an oximeter is disclosed. The oximeter includes an input capable of receiving intensity signal data responsive to intensity signals acquired from a detector capable of detecting light attenuated by body tissue, a first calculator configured to calculate a first indication of perfusion index using a first calculation technique, a second calculator configured to calculate a second indication of perfusion index using a second calculation technique and a processor configured to utilize at least one of the first and second calculators to determine a resulting indication of perfusion index. In an embodiment, the processor is configured to select the calculator which calculates the lowest indication of perfusion index. In an embodiment, the processor utilizes both calculation techniques. In an embodiment, the processor is further configured to select the lowest indication of perfusion index as the resulting indication of perfusion index.

In an embodiment, a method of determining an indication of a physiological condition using data responsive to intensity signals acquired from a detector capable of detecting light attenuated by body tissue is disclosed. The method includes the steps of determining one or more indications of pulse information from data responsive to intensity signals acquired from a detector capable of detecting light attenuated by body tissue, determining a first indication of amplitude data for a single pulse based on the one or more indications of pulse information, determining a second indication of amplitude data for a plurality of pulses based on the one or more indications of pulse information, determining a final indication of amplitude data based on the first and second indications and outputting the final indication. In an embodiment, the amplitude data is used to determine an indication of perfusion. In an embodiment, determining a final indication includes selecting the lowest indication of amplitude from the first and second indications of amplitude. In an embodiment, determining a final indication includes averaging the first and second indications of amplitude. In an embodiment, determining a final indication is based on a statistical analysis of the first and second indications of amplitude. In an embodiment, the combination includes an averaged combination of pulses. In an embodiment, the combination includes a maximum and minimum amplitude of a plurality of pulses. In an embodiment, the combination includes a statistical combination of pulses.

For purposes of summarizing the disclosure, certain aspects, advantages and novel features of the disclosure have been described herein. Of course, it is to be understood that not necessarily all such aspects, advantages or features will be embodied in any particular embodiment of the disclosure.

#### BRIEF DESCRIPTION OF THE DRAWINGS

A general architecture that implements the various features of the disclosure will now be described with reference to the drawings. The drawings and the associated descriptions are provided to illustrate embodiments of the disclosure and not to limit its scope.

FIG. 1 illustrates a graph showing an intensity “plethysmograph” oximetry waveform.

FIG. 2 illustrates a flow calculator capable of determining measurements for a perfusion index.

FIGS. 3A-3B illustrate patient monitors capable of calculating and displaying the measurements of FIG. 2.

FIG. 4 illustrates a simplified block diagram of a smoothed perfusion index generator, according to an embodiment of the disclosure.

FIG. 5 illustrates a flow chart of a smoothing process, according to an embodiment of the disclosure.

FIG. 6 illustrates another embodiment of a simplified block diagram of a smoothed perfusion index generator.

FIG. 7 illustrates a simplified block diagram of an embodiment of a PI determination system using multiple PI calculation techniques.

FIG. 8 illustrates a flow chart of a PI decision process, according to another embodiment of the disclosure.

#### DETAILED DESCRIPTION

FIG. 4 illustrates a simplified block diagram of a smoothed perfusion index generator 400, according to an embodiment of the disclosure. As shown, the generator 400 includes a flow calculator 402, a smoother 404 and optional indications of noise, including a measure of distortion 406, signal quality 408, and waveform quality 410. In an embodiment, a data signal 420 responsive to an intensity signal is input into the flow calculator 402, and a current value 422 of PI is calculated. A skilled artisan will recognize a number of calculations that can determine values of perfusion, including, for example, the foregoing ratio of the AC signal to the DC signal. The current value 422 of PI, which in an embodiment is subject to noise and distortion in the data signal 420, is input into the smoother 404, which reduces an error between the current value 422 of PI and actual perfusion conditions. For example, the smoother 404 may advantageously determine a baseline PI, and depending upon an indication of some or all of an amount of distortion, noise, signal quality, and/or waveform quality in the data signal 422, substitute or combine the baseline PI for or with the current value 422 to generate an output PI 430.

In an embodiment, the wavelength used to determine PI is in the infrared (IR) spectrum. IR wavelengths are more independent of saturation than are wavelengths in, for example, the Red (R) spectrum. As a result, when the saturation changes, the PI calculated from a R wavelength tends to vary greater than the PI calculated from a IR wavelength.

In an embodiment, the distortion signal 406 may comprise a Boolean value indicating whether the data signal 422 includes, for example, motion-induced noise. Although an artisan will recognize from the disclosure herein a number of methodologies for deriving the distortion signal 406, derivation of a Boolean distortion signal is disclosed in U.S. Pat. No. 6,606,511, incorporated herein by reference. Alternatively, or in addition to, the signal quality signal 408 may comprise a Boolean value indicating whether the data signal 422 meets various waveform criteria. Although an artisan will recognize from the disclosure herein a number of methodologies for deriving the signal quality signal 408, derivation of a Boolean distortion signal is disclosed in the '511 patent. Alternatively, or in addition to, a feature extractor 440 may advantageously produce waveform quality outputs 410, indicative of waveform quality or waveform shape. Although an artisan will recognize from the disclosure herein a number of methodologies for deriving the waveform quality signal 410, derivation thereof is disclosed in the '065 patent.

Thus, the smoother 404 accepts one or more or different indicators of the quality of the data signal 420, and determines

how to smooth the PI output to reduce errors between data trends and actual perfusion conditions. In an embodiment, the smoothing may advantageously comprise statistical weighting, other statistical combinations, or simply passing the PI 422 through to the output, depending upon one or more of the quality signals 406, 408, 410, or logical combinations thereof. In an embodiment, the smoother 404 selects the lowest PI value to pass to the output PI 422. This is because motion noise tends to increase PI, thus the lower PI value tends to be the more accurate value.

Upon the output of a smoothed PI measurement, a monitor may advantageously audibly and/or visually presents the measurement to a caregiver, and when the measurement meets certain defined thresholds or behaviors, the monitor may advantageously audibly and/or visually alert the caregiver. In other embodiments, the monitor may communicate with other computing devices to alert the caregiver, may compare longer term trend data before alarming, or the like.

FIG. 5 illustrates a flow chart of a smoothing process 500, according to an embodiment of the disclosure. In block 502, data is acquired responsive to one or more of multiple channel intensity signals. In block 504, a determination is made whether distortion is present, whether signal quality is good, whether there is motion-induced-noise or the like. When acceptable noise levels exist, in block 506, the baseline PI becomes the current PI and in block 508, the baseline PI is output. However, when unacceptable signal quality or the like is detected, the current PI is compared to the baseline PI. When the current PI is smaller than the baseline PI, in block 506, the baseline PI becomes the current PI. However, when the current PI is greater than or equal to the baseline PI, the baseline PI is output in block 510. Thus, the smoothing process 500 determines when a baseline PI can be acquired in quality monitoring conditions, and then uses that baseline PI to avoid drift or other errors that may deteriorate the accuracy of the PI output. An artisan will recognize from the disclosure herein that the baseline PI could be reset periodically, some or all iterations, when other occurrences or measurements suggest a reinitialization, when various trends occur, or the like.

FIG. 6 illustrates another embodiment of a simplified block diagram of a smoothed perfusion index generator 600. As shown, the generator 600 includes a smoother 604 and optional indications of noise, including a measure of distortion 606, signal quality 608, waveform quality 610, and Pleth Feature Extractor similar to those described with respect to FIG. 4. In an embodiment, a data signal 620 responsive to an intensity signal is input into the PI Analyzer 602, and a PI value 422 is outputted for use by the smoother 604. In an embodiment, the PI Analyzer employs multiple different calculation techniques to determine a more accurate indication of PI. In an embodiment, based on the indications of distortion signal quality, waveform quality and/or other indications of signal quality, a specific calculation technique is used to determine a PI output value 622.

FIG. 7 illustrates a simplified block diagram of an embodiment of a PI determination system 700 using multiple PI calculation techniques. As shown, pleth data 720 is input into the system. The pleth data 720 is then routed to at least two different PI calculators 702, 704. In an embodiment, more than two different types of calculation techniques can be used. The at least two PI calculators 702, 704 output PI indications for input into the PI selector 706. The PI selector 706 determines a PI value to output. In an embodiment, the PI selector chooses the lowest PI value. In general, the lower PI value should be the more accurate value, particularly in the presence of motion induced noise. This is because motion induced noise tends to raise PI values. In an embodiment, the

PI selector **706** averages or otherwise analyzes the PI values using statistical modeling in order to determine a more accurate value of PI.

In an embodiment, one of the PI calculators **702, 704** determines a PI value based on pulse by pulse determination of PI, such as, for example, using the following PI formula as described above:

$$PI = (\lambda_{max} - \lambda_{min}) / \lambda_{DC}$$

In an embodiment, one of the PI calculators **702, 704** determines a PI value based on a fixed or variable interval of pleth data including more than one pulse, in effect calculating a bulk PI.

FIG. **8** illustrates a flow chart of a PI decision process **800**, according to another embodiment of the disclosure. At block **802**, the process **800** receives pleth data **802**. The process then moves to block **804** where the process **800** calculates at least two different PI indications, such as, for example, as described with respect to FIG. **7**. The process **800** then moves to block **806** where an indication of PI is determined based on the different calculations, again, such as, for example, as described with respect to FIG. **7**. The process **800** then repeats itself for each PI value determination.

While the above perfusion index determination system has been described in certain embodiments herein, other embodiments of the present disclosure will be known to those of skill in the art from the descriptions herein. Moreover, the described embodiments have been presented by way of example only, and are not intended to limit the scope of the disclosure. Moreover, those of skill in the art understand that information and signals can be represented using a variety of different technologies and techniques. For example, data, instructions, commands, information, signals, bits, symbols, and chips that can be referenced throughout the above description may be represented by voltages, currents, electromagnetic waves, magnetic fields or particles, optical fields or particles, or any combination thereof.

Those of skill in the art further appreciate that the various illustrative logical blocks, modules, circuits, and algorithm steps described in connection with the embodiments disclosed herein can be implemented as electronic hardware, computer software, or combinations of both. To illustrate this interchangeability of hardware and software, various illustrative components, blocks, modules, circuits, and steps have been described above generally in terms of their functionality. Whether such functionality is implemented as hardware or software depends upon the particular application and design constraints imposed on the overall system. Skilled artisans can implement the described functionality in varying ways for each particular application, but such implementation decisions should not be interpreted as causing a departure from the scope of the present disclosure.

The various illustrative logical blocks, modules, and circuits described in connection with the embodiments disclosed herein can be implemented or performed with a general purpose processor, a digital signal processor (DSP), an application specific integrated circuit (ASIC), a field programmable gate array (FPGA) or other programmable logic device, discrete gate or transistor logic, discrete hardware components, or any combination thereof designed to perform the functions described herein. A general purpose processor can be a microprocessor, but in the alternative, the processor can be any conventional processor, controller, microcontroller, or state machine. A processor can also be implemented as a combination of computing devices, e.g., a combination of a DSP and a microprocessor, a plurality of microprocessors,

one or more microprocessors in conjunction with a DSP core, or any other such configuration.

The steps of a method or algorithm described in connection with the embodiments disclosed herein can be embodied directly in hardware, in a software module executed by a processor, or in a combination of the two. A software module can reside in RAM memory, flash memory, ROM memory, EPROM memory, EEPROM memory, registers, hard disk, a removable disk, a CD-ROM, or other form of storage medium known in the art. A storage medium is coupled to the processor, such that the processor can read information from, and write information to, the storage medium. In the alternative, the storage medium can be integral to the processor. The processor and the storage medium can reside in an ASIC. The ASIC can reside in a user terminal, physiological monitor and/or sensor. The processor and the storage medium can reside as discrete components in a user terminal, physiological monitor and/or sensor.

Although the foregoing disclosure has been described in terms of certain preferred embodiments, other embodiments will be apparent to those of ordinary skill in the art from the disclosure herein. Additionally, other combinations, omissions, substitutions and modifications will be apparent to the skilled artisan in view of the disclosure herein. Moreover, it is contemplated that various aspects and features of the disclosure described can be practiced separately, combined together, or substituted for one another, and that a variety of combination and subcombinations of the features and aspects can be made and still fall within the scope of the disclosure. Furthermore, the systems described above need not include all of the modules and functions described in the preferred embodiments. Accordingly, the present disclosure is not intended to be limited by the recitation of the preferred embodiments, but is to be defined by reference to the appended claims.

Additionally, all publications, patents, and patent applications mentioned in this specification are herein incorporated by reference to the same extent as if each individual publication, patent, or patent application was specifically and individually indicated to be incorporated by reference.

What is claimed is:

1. A method of determining an indication of perfusion index in a patient monitor, the method comprising:
  - receiving pleth data;
  - calculating at least two indications of perfusion index using at least two different calculation techniques; and
  - determining a final indication of perfusion index based on the at least two indications of perfusion index; wherein the final indication of perfusion index is determined by selecting the lowest indication of perfusion index.
2. A method of determining an indication of perfusion index, the method comprising:
  - receiving pleth data; and
  - determining an indication of perfusion index by utilizing at least one of a first calculation technique and a second calculation technique to determine a resulting indication of perfusion index; wherein determining the indication of perfusion index comprises choosing the calculation technique that will result in the lowest perfusion index value.
3. An oximeter comprising:
  - an input capable of receiving intensity signal data responsive to intensity signals acquired from a detector capable of detecting light attenuated by body tissue,

a first calculation calculator configured to calculate a first indication of perfusion index using a first calculation technique;  
a second calculator configured to calculate a second indication of perfusion index using a second calculation 5 technique; and  
a processor configured to utilize at least one of the first and second calculators to determine a resulting indication of perfusion index,  
wherein the processor is configured to select the calculator 10 which calculates the lowest indication of perfusion index.  
4. The method of claim 3, wherein the processor utilizes both calculation techniques.

\* \* \* \* \*



专利名称(译)	灌注指数更平滑		
公开(公告)号	<a href="#">US8983564</a>	公开(公告)日	2015-03-17
申请号	US13/627855	申请日	2012-09-26
[标]申请(专利权)人(译)	梅西莫股份有限公司		
当前申请(专利权)人(译)	Masimo公司		
[标]发明人	AL ALI AMMAR		
发明人	AL-ALI, AMMAR		
IPC分类号	A61B5/1455 A61B5/00 A61B5/0205 A61B5/026 A61B5/0295		
CPC分类号	A61B5/0295 A61B5/0261 A61B5/0205 A61B5/7278 A61B5/14551 A61B5/7207 A61B5/14552 A61B5/7282		
优先权	60/851346 2006-10-12 US		
其他公开文献	US20130079610A1		
外部链接	<a href="#">Espacenet</a> <a href="#">USPTO</a>		

摘要(译)

本公开的实施例寻求通过使用基线灌注指数测量和/或通过使用多个PI计算来平滑灌注指数测量。基线灌注指数测量的组合减少了计算的PI测量值与实际条件之间的误差。

