



US006869414B2

(12) **United States Patent**
Simpson et al.

(10) **Patent No.:** **US 6,869,414 B2**
(45) **Date of Patent:** **Mar. 22, 2005**

(54) **PRE-SHAPED CATHETER WITH PROXIMAL ARTICULATION AND PRE-FORMED DISTAL END**

(75) Inventors: **John A. Simpson**, Carlsbad, CA (US);
Robert C. Hayzelden, Canyon Lake, CA (US); **Wade A. Bowe**, Temecula, CA (US)

(73) Assignee: **Cardiac Pacemakers, Inc.**, St. Paul, MN (US)

(*) Notice: Subject to any disclaimer, the term of this patent is extended or adjusted under 35 U.S.C. 154(b) by 24 days.

(21) Appl. No.: **10/105,087**

(22) Filed: **Mar. 22, 2002**

(65) **Prior Publication Data**

US 2003/0181855 A1 Sep. 25, 2003

(51) **Int. Cl.**⁷ **A61M 31/00**; A61M 37/00;
A61M 25/00; A61B 5/00

(52) **U.S. Cl.** **604/95.04**; 600/585

(58) **Field of Search** 604/93.01, 95.01,
604/95.04, 523, 528; 600/433, 434, 435,
585

(56) **References Cited**

U.S. PATENT DOCUMENTS

5,195,968 A 3/1993 Lundquist et al.

5,389,090 A	2/1995	Fischell et al.	
6,059,778 A	5/2000	Sherman	
6,066,126 A	5/2000	Li et al.	
6,096,036 A	8/2000	Bowe et al.	
6,198,974 B1 *	3/2001	Webster, Jr.	607/122
6,270,496 B1	8/2001	Bowe et al.	
6,280,433 B1	8/2001	McIvor et al.	
6,408,214 B1	6/2002	Williams et al.	
6,530,914 B1	3/2003	Mickley	

* cited by examiner

Primary Examiner—Nicholas D. Lucchesi

Assistant Examiner—Mark K. Han

(74) *Attorney, Agent, or Firm*—Crawford Maunu PLLC

(57) **ABSTRACT**

A catheter employs a pre-formed distal end and a proximal deflection mechanism for steering the catheter. A shaped member extends from a shaped region of the catheter sheath to at least a portion of an anchor region. A steering ribbon extends from a proximal region of the sheath and passes within at least a portion of the anchor region. A distal end of the steering ribbon is joined with a proximal portion of the shaped member. At least one steering tendon is disposed within the sheath and has a first end attached at the anchor region and a second end located at the proximal region of the sheath. Movement of the steering tendon in a proximal direction causes the deflection region to deflect relative to the longitudinal axis of the catheter while the shape of shaped region of the sheath is substantially maintained.

46 Claims, 7 Drawing Sheets

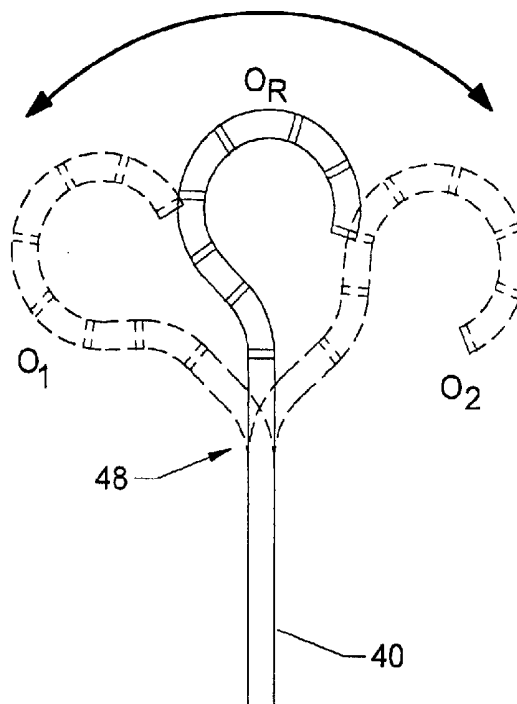
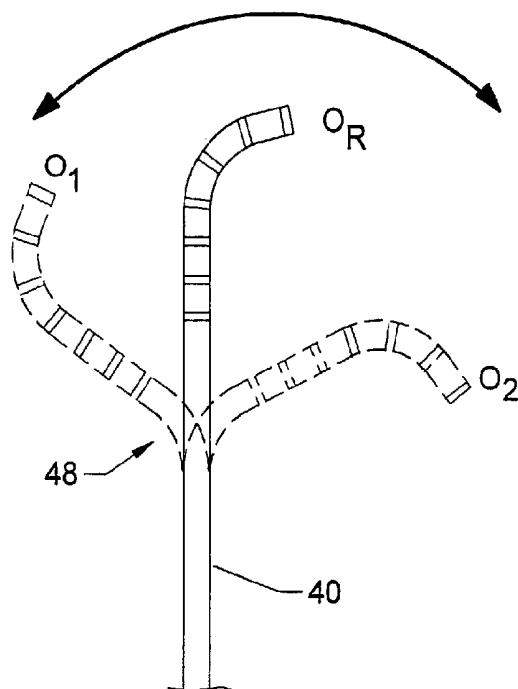

RELAXED CONFIGURATION

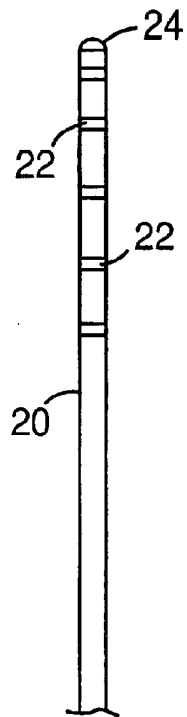

Fig. 1
PRIOR ART

STEERED CONFIGURATION

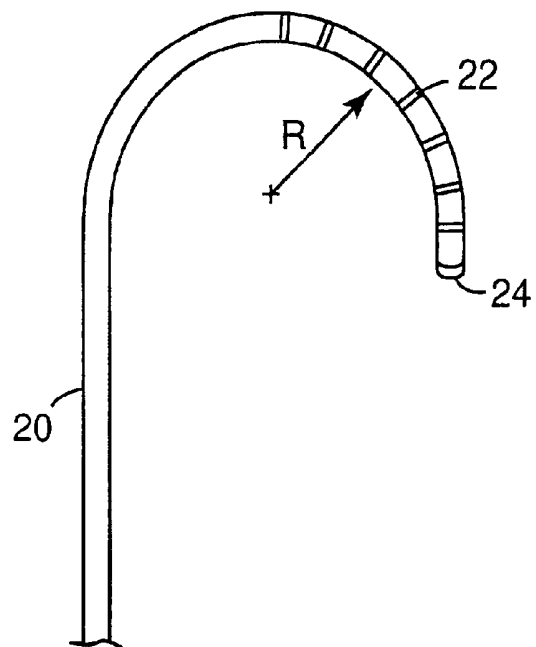

Fig. 2
PRIOR ART

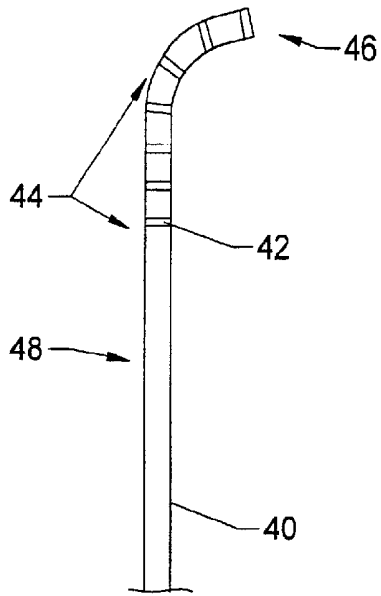

Fig. 3A

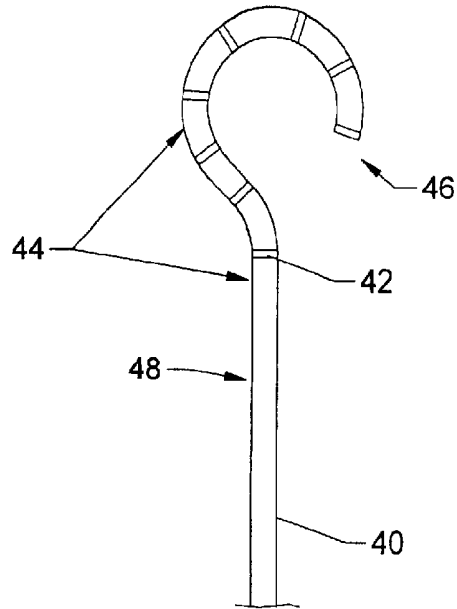

Fig. 3B

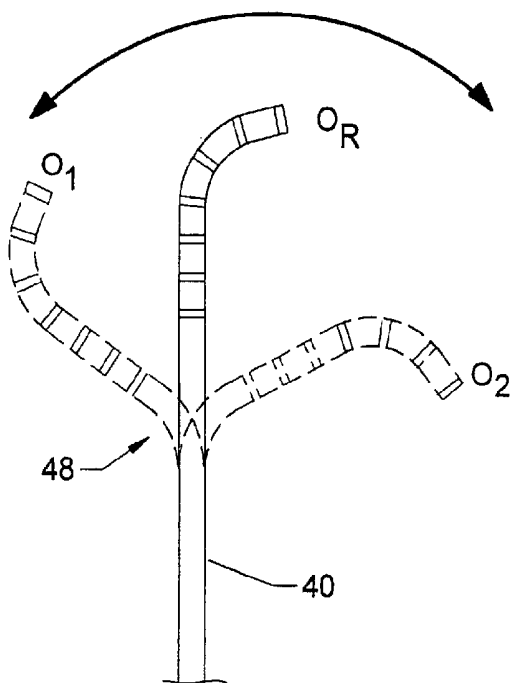

Fig. 4A

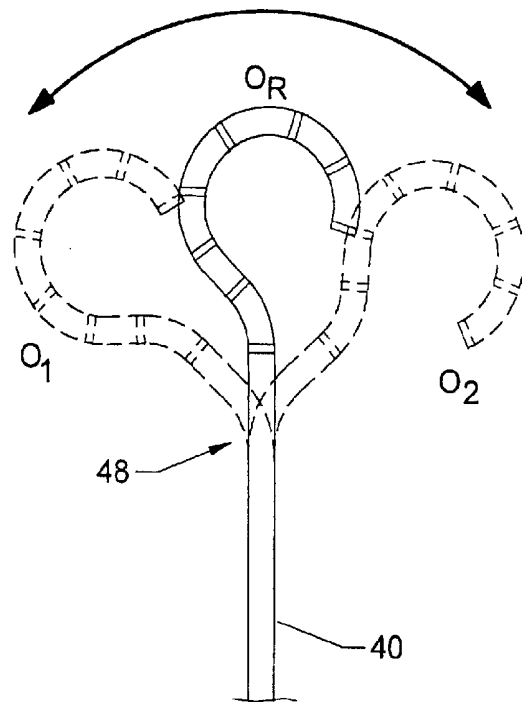

Fig. 4B

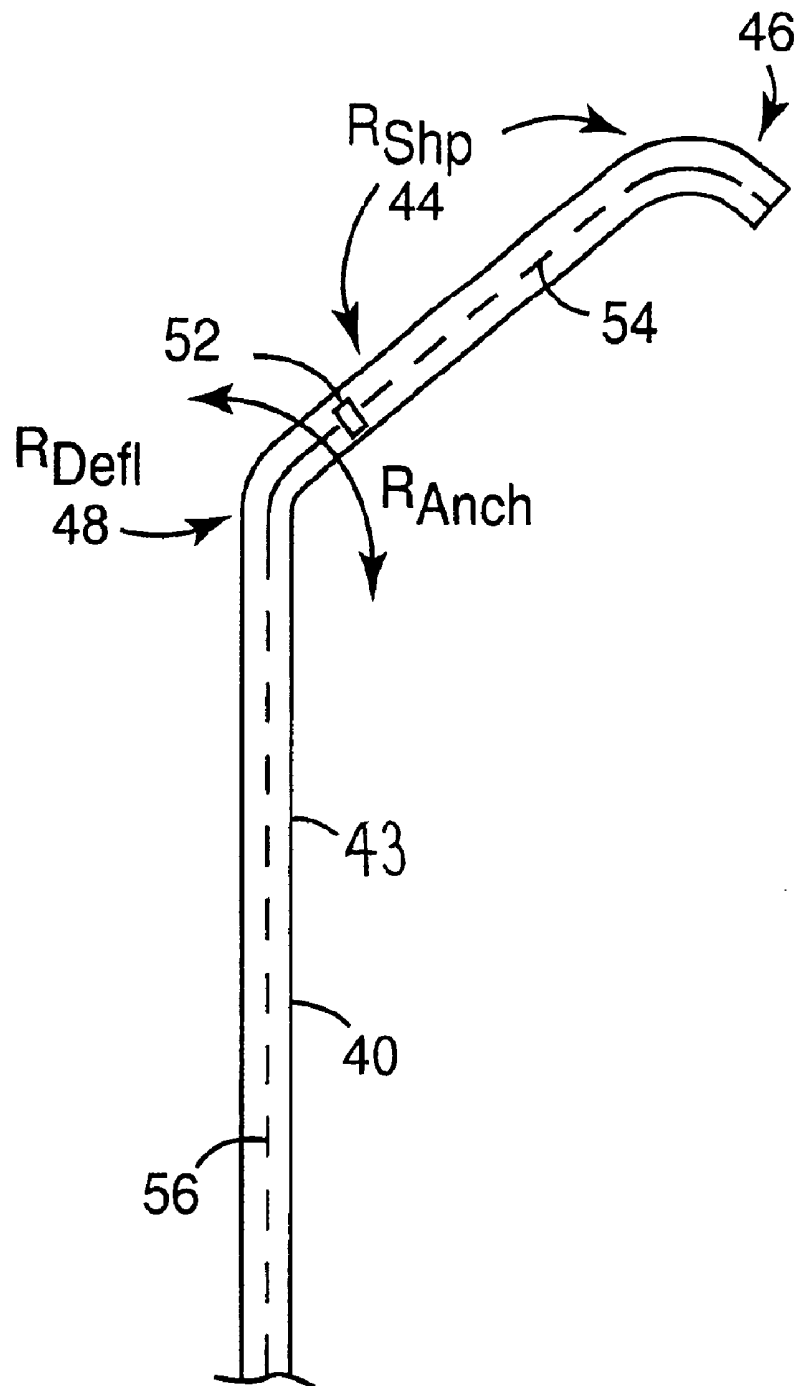

Fig. 5

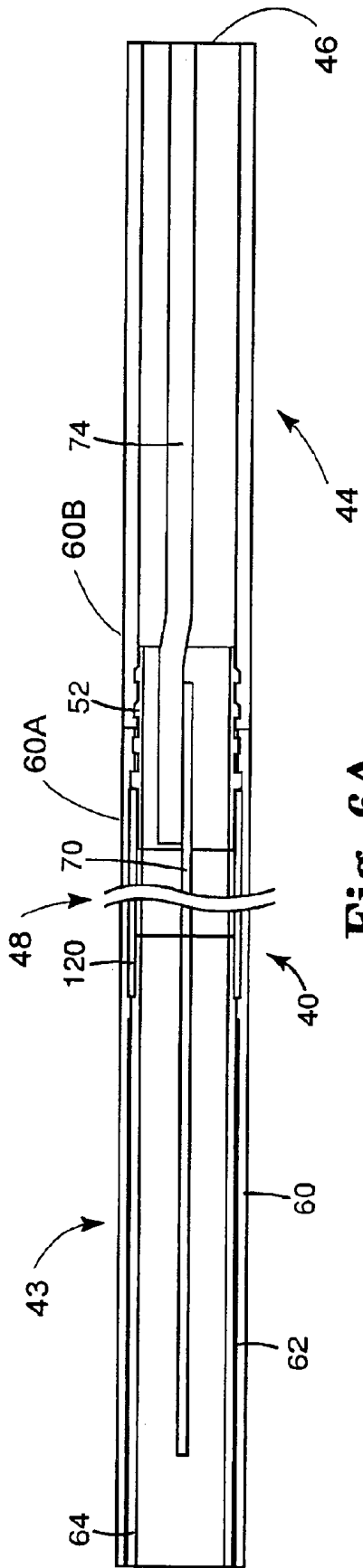

Fig. 6A

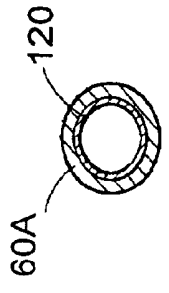

Fig. 6B

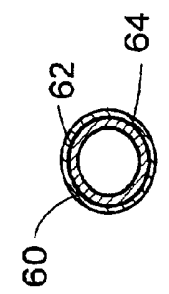

Fig. 6C

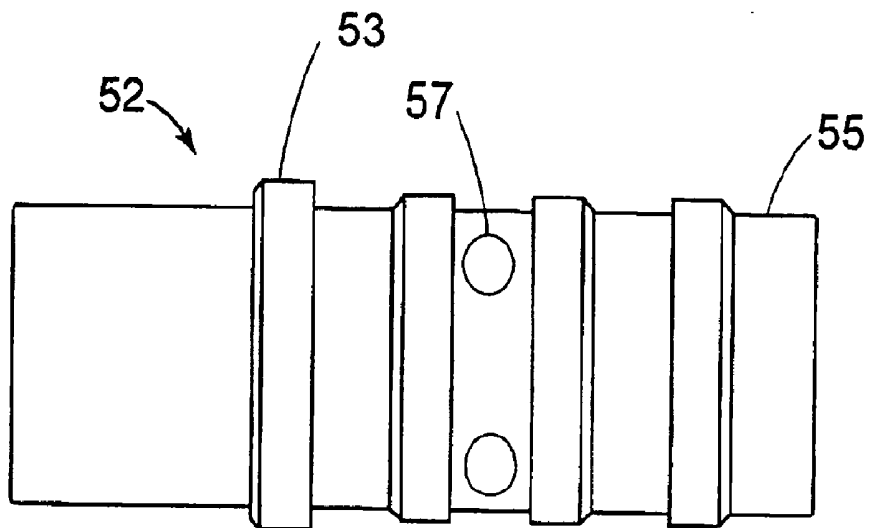

Fig. 7A

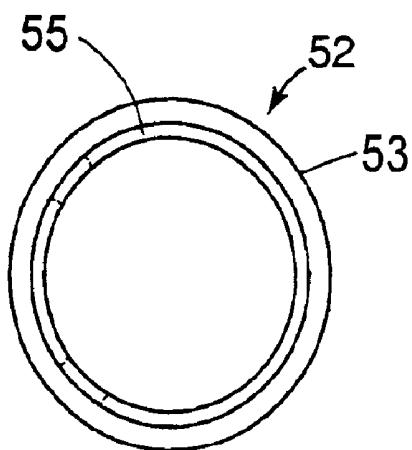

Fig. 7B

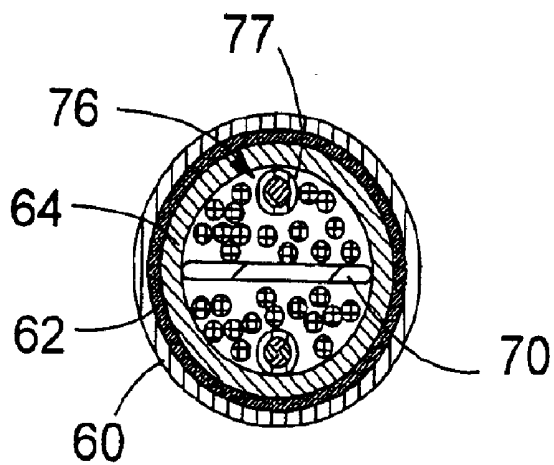

Fig. 8A

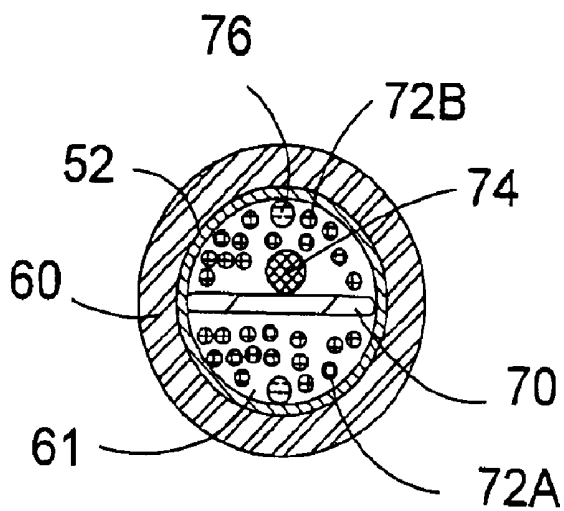

Fig. 8B

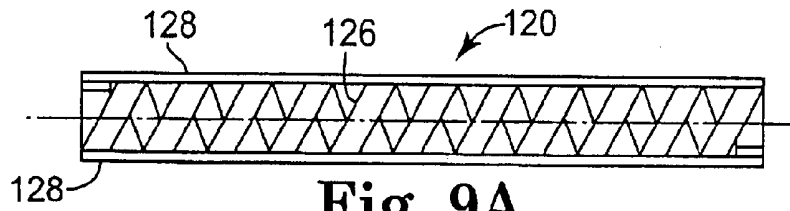

Fig. 9A

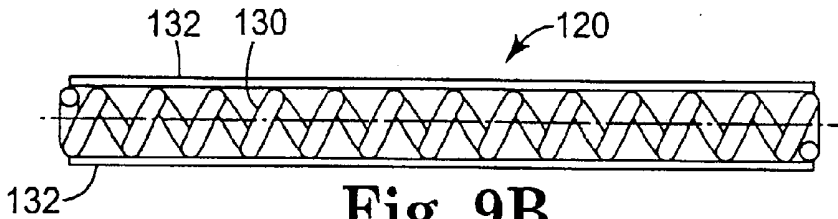

Fig. 9B

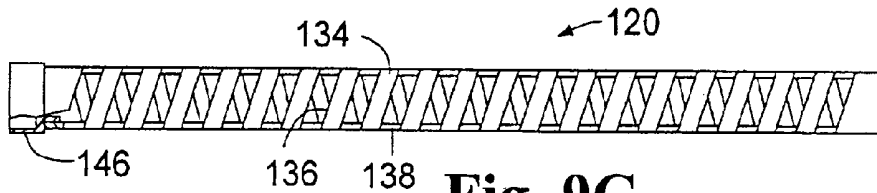

Fig. 9C

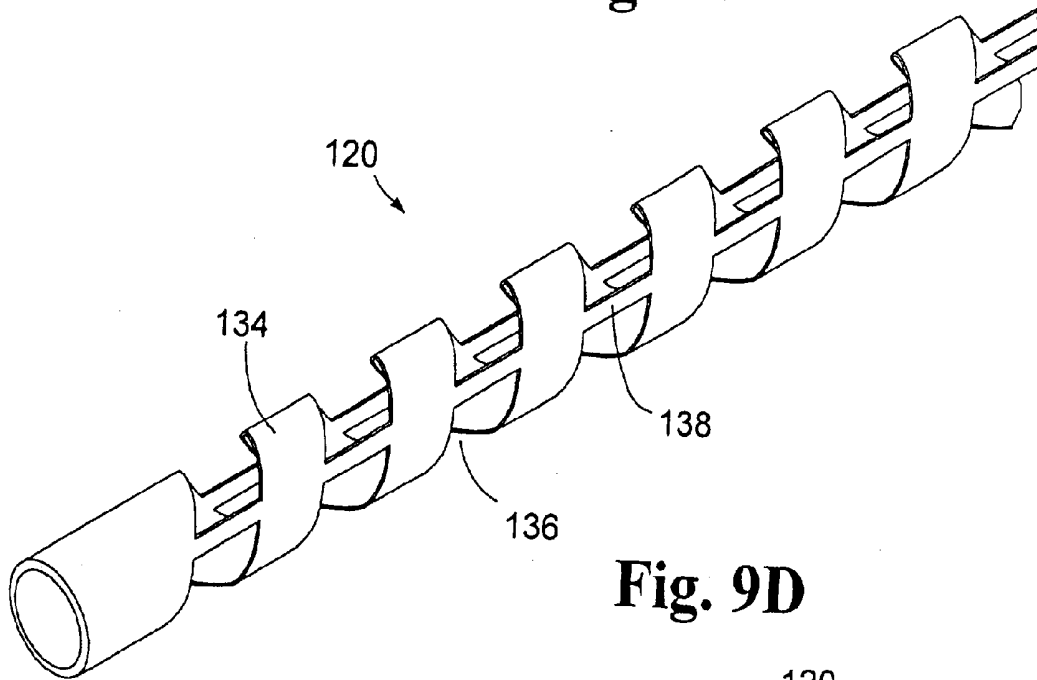

Fig. 9D

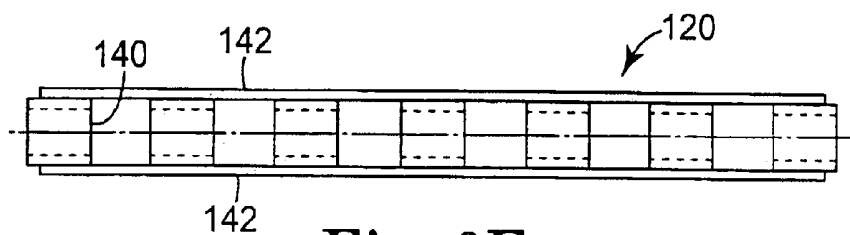

Fig. 9E

PRE-SHAPED CATHETER WITH PROXIMAL ARTICULATION AND PRE-FORMED DISTAL END

FIELD OF THE INVENTION

The present invention relates generally to steerable catheters and, more particularly, to a steerable catheter employing a pre-formed distal end section and a proximal steering mechanism.

BACKGROUND OF THE INVENTION

Mapping and ablation catheters are well-established technologies that allow the physician to locate and treat damaged cardiac tissue. Presently, a considerable amount of time is often spent by the physician when manipulating such catheters within cardiac structures, such as the right atrium, simply trying to locate an anatomical feature of interest, such as the coronary sinus ostium.

A pre-shaped guiding catheter is typically used to blindly locate the coronary sinus ostium, but this endeavor is complicated by the fact that the location of the coronary sinus ostium may vary appreciably from one patient to another, especially among patients with diseased hearts. Oftentimes, the clinician is entirely unable to locate the coronary sinus ostium using the guiding catheter, and must resort to finding the ostium by "mapping" (interpreting localized bipolar waveforms) using an electrophysiological (EP) catheter and an ECG monitor. After the ostium is located, a guiding catheter or sheath is typically used to inject radiographic contrast media into the coronary sinus to highlight the associated venous system, and then a pacing lead is installed within one of the coronary branches.

Steerability is also important for ablation catheter implementations. In many cases, ablation of the damaged tissue can restore the correct operation of the heart. Ablation can be performed, for example, by percutaneous ablation, a procedure in which a catheter is percutaneously introduced into the patient and directed through an artery to the atrium or ventricle of the heart to perform single or multiple diagnostic, therapeutic, and/or surgical procedures. In such a case, an ablation procedure is used to destroy the tissue causing the arrhythmia in an attempt to remove the electrical signal irregularities or create a conductive tissue block to restore normal heartbeat or at least an improved heartbeat. Successful ablation of the conductive tissue at the arrhythmia initiation site usually terminates the arrhythmia or at least moderates the heart rhythm to acceptable levels. A widely accepted treatment for arrhythmia involves the application of radio frequency (RF) energy to the conductive tissue.

By way of example, a procedure to address atrial fibrillation, referred to as Cox's Maze procedure, involves the development of continuous atrial incisions to prevent atrial re-entry and to allow sinus impulses to activate the entire myocardium. While this procedure has been found to be successful, it involves an intensely invasive approach. It is more desirable to accomplish the same result as the Maze procedure by use of a less invasive approach, such as through the use of an appropriate electrophysiological (EP) catheter system having enhanced steering and shape adjustment capabilities.

Steerable conventional mapping and ablation catheter systems are typically configured to allow the profile of the distal end of the catheter to be manipulated from a location outside the patient's body. The contours of pre-shaped

diagnostic catheters, for example, are generally fixed, and this is typically achieved in production by constraining the distal end within a shaping fixture while warming them until they assume the intended shape (i.e., by "heat setting" their polymer shaft). The shape of steerable mapping catheters, on the other hand, can be altered by the user simply by applying tension to one or more internal steering tendons affixed to a distal-end tip of the catheter. However, most steerable mapping catheters are generally straight when no tension is applied to the tendons. When steered, the distal end of such steerable catheters assumes a semicircular arc or full circular shape whose radius of curvature depends upon the amount of tension applied to the steering tendon.

FIGS. 1 and 2 illustrate a conventional steerable catheter in a relaxed configuration and a steered configuration, respectively. Catheter 20 is shown to include a number of band electrodes 22 and a tip electrode 24. As can be seen in FIG. 1, catheter 20 maintains a relatively straight profile while in a relaxed configuration.

FIG. 2 illustrates the catheter 20 of FIG. 1 in a steered configuration. According to this and other conventional steerable catheter implementations, catheter 20 has a distal end that assumes a semicircular arc or a fully circular shape when tension is applied to the catheter's steering tendon(s). The circular arc of catheter 20, when in its steered configuration, develops a shape whose radius, R , of curvature depends upon the amount of tension applied to the distal end vis-a-vis the steering tendon(s). It will be appreciated by those skilled in the art that enhanced steering capabilities are often required over and above those offered by conventional steerable catheters, such as those of the type depicted in FIGS. 1 and 2, for locating (e.g., such as by mapping) certain anatomical features and performing an ablation technique once such anatomical features have been located and accessed.

There is a need for an improved steerable catheter having enhanced steering capabilities for mapping and ablation applications. There exists a further need for such a catheter that provides for increased lumen space for accommodating larger payloads and one that resists deformation after repeated steering. The present invention fulfills these and other needs, and addresses other deficiencies of prior art implementations.

SUMMARY OF THE INVENTION

The present invention is directed to a catheter employing a pre-formed distal end and a proximal deflection mechanism for steering the catheter. According to one embodiment of the present invention, the catheter includes a sheath having a proximal region, a deflection region, a distal-end region including a shaped region, an anchor region defined between the deflection region and the shaped region, and a longitudinal axis. A shaped member extends from the shaped region of the sheath to at least a portion of the anchor region. The shaped region of the sheath is deformable to a shape substantially that of the shaped member. A steering ribbon may be included that extends from the proximal region of the sheath and passes within at least a portion of the anchor region. A distal end of the steering ribbon is joined with a proximal portion of the shaped member.

At least one steering tendon is disposed within the sheath. The steering tendon has a first end attached at the anchor region and a second end located at the proximal region of the sheath. Movement of the steering tendon in a proximal direction causes the deflection region to deflect relative to the longitudinal axis while the shape of shaped region of the

sheath is substantially maintained. In another configuration, the tendon may be slidably attached to the walls of the sheath proximal to the first end of the tendon.

The shaped member is preferably shaped to facilitate movement of the catheter relative to a specified anatomical feature. The shaped member, according to one embodiment, is formed of a resilient material having a pre-formed configuration. The pre-formed configuration of the shaped member is deformable to a substantially straightened configuration to facilitate movement of the catheter through vasculature. The shaped member returns to the pre-formed configuration when unconstrained by the vasculature.

In one configuration, the shaped member is a pre-formed outer portion of the sheath. In another configuration, the shaped member includes a stylet having a pre-established shape. According to this configuration, the shaped member is secured to a distal end of the catheter. In another configuration, the shaped member is fixably attached to the anchor region.

The shaped member may be configured to include a flattened proximal portion. The proximal portion of the shaped member is preferably joined to a distal portion of the steering ribbon. For example, the proximal portion of the shaped member is joined to the distal portion of the steering ribbon by a weld, a solder joint or an adhesive to form a lap joint.

The anchor region includes an anchor band within which a distal portion of the steering ribbon and the proximal portion of the shaped member are joined. A steering tendon is connected to a location of the anchor band offset from the longitudinal axis of the sheath. In one implementation, a number of electrical conductors pass through the anchor band. Filler material may be used to substantially fill voids within the anchor band to prevent shifting of the electrical conductors within the anchor band.

The steering ribbon is formed from a resilient material and has a flattened shape. The steering ribbon preferably has a width sufficient to match an inner diameter of the sheath. For example, the width of the steering ribbon is sufficient to contact an inner surface of the sheath at two diametrically opposite locations of the sheath's inner surface. The steering ribbon, in one configuration, separates a first steering tendon from a second steering tendon also passing through the deflection region. The steering ribbon, according to one embodiment, is integrally formed with the shaped member.

The catheter may further include a support structure extending over all or a portion of the deflection region. The support structure is configured to deflect laterally relative to the longitudinal axis and to resist axial compression along the longitudinal axis of the sheath. The support system is formed of a resiliently deformable, superelastic material. In one configuration, the support system includes a substantially tubular member comprising an array of notches. In another configuration, the support system includes a linear array of apertured rings defining a lumen, and at least one strut secured to one side of each of the rings. In such a configuration, a pair of struts are secured to diametrically opposite sides of each of the rings. In yet another configuration, the support system includes a substantially tubular member with notches cut at a pitch angle such that the remaining material is comprised of a continuous helix with a set of struts on diametrically opposite sides of the helix.

According to a further embodiment of the present invention, at least one electrode is located at a distal-end tip of the sheath. In another configuration, a number of elec-

trodes are located at one or both of the distal end and deflection regions for sensing cardiac signals or for transferring energy to biological tissue. By way of example, a number of electrodes are located at one or both of the distal end and deflection regions. A first set of electrical conductors is coupled to a first number of the electrodes, and a second set of electrical conductors is coupled to a second number of the electrodes. The first and second electrical conductor sets extend from the distal-end region to at least the proximal region of the sheath. The steering ribbon separates the first set of electrical conductors from the second set of electrical conductors.

In yet another embodiment of the present invention, a method of accessing vasculature and cardiac structures involves providing a catheter including a proximal region, a pre-formed region at a distal end of the catheter, a deflection mechanism proximal to the pre-formed region, a deflection region proximal to the deflection mechanism, and a longitudinal axis. The method involves applying an axial force in a proximal direction to the deflection mechanism, the axial force causing the deflection region to deflect relative to a longitudinal axis of the proximal region of the catheter while a pre-formed shape of the pre-formed region is substantially maintained. The method further involves resisting axial compression along the longitudinal axis at the deflection region resulting from application of the axial force.

According to another aspect, the method involves deforming the pre-formed region to a substantially straightened configuration to facilitate movement of the catheter through vasculature, and resuming the pre-formed region to the pre-formed shape when unconstrained by the vasculature. Another aspect involves applying the axial force to the deflection mechanism to change a bend angle at the deflection region while the pre-formed shape of the pre-formed region is substantially maintained. Cardiac signals can be sensed at the pre-formed region of the catheter. Energy can be delivered from the pre-formed region of the catheter to cardiac tissue.

In a further embodiment, a method of accessing vasculature and cardiac structures involves inserting the catheter into a patient. According to one particular approach, an introducer sheath is inserted into a selected cardiac structure. The catheter is guided through the introducer sheath. The pre-formed region of the catheter is extended beyond a distal end of the introducer sheath thereby allowing the pre-formed region of the catheter to resume its pre-formed shape.

The above summary of the present invention is not intended to describe each embodiment or every implementation of the present invention. Advantages and attainments, together with a more complete understanding of the invention, will become apparent and appreciated by referring to the following detailed description and claims taken in conjunction with the accompanying drawings.

BRIEF DESCRIPTION OF THE DRAWINGS

FIG. 1 is a depiction of a catheter employing a prior art steering mechanism, the catheter shown in a relaxed configuration;

FIG. 2 is a depiction of the catheter of FIG. 1 shown in a steered configuration;

FIG. 3A is a depiction of a catheter employing a proximal steering mechanism and pre-shaped distal end in accordance with an embodiment of the present invention, the catheter shown in a relaxed configuration;

FIG. 3B is a depiction of a catheter employing a proximal steering mechanism and looped pre-shaped distal end in

accordance with another embodiment of the present invention, the catheter shown in a relaxed configuration;

FIG. 4A is a depiction of the catheter of FIG. 3A shown in several steered configurations;

FIG. 4B is a depiction of the catheter of FIG. 3B shown in several steered configurations;

FIG. 5 is a depiction of a catheter employing a proximal steering mechanism and pre-shaped distal end in accordance with an embodiment of the present invention;

FIG. 6A is a cross-sectional view of a catheter employing a proximal steering mechanism in accordance with an embodiment of the present invention;

FIG. 6B is a cross-sectional view of the catheter shaft subassembly at a proximal section of the catheter shown in FIG. 6A;

FIG. 6C is a cross-sectional view of the catheter shaft subassembly of the catheter depicted in FIG. 6A taken at a deflection region situated between the proximal section and an anchor section of the catheter shown in FIG. 6A;

FIG. 7A is a side view of the anchor section of the catheter shown in FIG. 6A;

FIG. 7B is a cross-sectional view of the anchor section of the catheter shown in FIG. 6A;

FIG. 8A is a more detailed cross-sectional view of a proximal section of the catheter shown in FIG. 6A according to an embodiment of the present invention;

FIG. 8B is a more detailed cross-sectional view of the anchor section of the catheter shown in FIG. 6A according to an embodiment of the present invention;

FIG. 9A is a view of a support system comprising a flat-wired coil and struts;

FIG. 9B is a view of a support system comprising a round-wire coil and struts;

FIG. 9C is a view of a support system comprising a tubular member with an array of deep notches;

FIG. 9D is a perspective view of the support system shown in FIG. 9C; and

FIG. 9E is a view of a support system comprising a linear array of hollow rings connected with struts.

While the invention is amenable to various modifications and alternative forms, specifics thereof have been shown by way of example in the drawings and will be described in detail hereinbelow. It is to be understood, however, that the intention is not to limit the invention to the particular embodiments described. On the contrary, the invention is intended to cover all modifications, equivalents, and alternatives falling within the scope of the invention as defined by the appended claims.

DETAILED DESCRIPTION OF VARIOUS EMBODIMENTS

In the following description of the illustrated embodiments, references are made to the accompanying drawings which form a part hereof, and in which is shown by way of illustration, various embodiments in which the invention may be practiced. It is to be understood that other embodiments may be utilized, and structural and functional changes may be made without departing from the scope of the present invention.

Referring now to the drawings, and in particular to FIG. 3A, there is illustrated a catheter implemented in accordance with an embodiment of the present invention. The catheter 40 advantageously employs a pre-shaped distal section in combination with a deflectable proximal section which

advantageously provides for controlled articulation of the catheter 40 without significantly altering the distal section's predetermined shape. In accordance with this embodiment, catheter 40 is shown to include a pre-shaped section 44 extending from a distal tip 46 of the catheter 40 toward a deflection section 48. The deflection section 48 provides for controlled articulation of the pre-shaped section 44 and distal tip 46 for steering the catheter 40 through vasculature and cardiac structures and for dynamically adjusting the overall contour of the catheter 40 during use. The pre-shaped section 44 and distal tip 46 are preferably formed of a resilient material such that the pre-formed shape of the various catheter sections can effectively be straightened when the catheter 40 is inserted into a patient's vasculature or other constraining tissue structure.

A catheter 40 implemented in accordance with the present invention may be used in many applications, such as in mapping or ablation applications. If catheter 40 is equipped with thermal sensors, for example, catheter 40 can be used to generate long, continuous lesions for the treatment of atrial fibrillation or atrial flutter.

An articulating catheter 40 in accordance with the present invention may be implemented in a variety of forms, such as in the form of an electrophysiological (EP) mapping catheter having multiple band electrodes 42. The band electrodes 42 disposed at the distal-end region of catheter 40 are used to collect localized ECG signals for the specialized purpose of locating the coronary sinus. It is readily appreciated by those skilled in the art that the articulating catheter of the present invention can also be used to deliver radio frequency (RF) energy to locally ablate cardiac tissue and thereby alter its inherent electrical conduction.

By way of further example, an articulating catheter 40 employing a pre-shaped distal section 44 and deflectable proximal section 48 may be used within the right atrium for mapping purposes to positively locate the ostium of the coronary sinus. It is well understood in the art that this activity is known to be particularly challenging within hearts where the anatomy has been distorted by chronic disease, such as congestive heart failure (CHF) or atrial fibrillation (AF). It is necessary, for example, to specifically locate the coronary sinus when implanting one of the pacemaker leads for synchronized dual-chamber pacing CHF patients. A shape-adjustable catheter implemented according to the principles of the present invention can be used to efficiently locate the coronary sinus and other anatomical features of interest.

In accordance with a further illustrative example, an alternate distal configuration of the catheter 40 is illustrated in FIG. 3B. The combination of a pre-shaped distal portion 44 and a deflectable proximal section 48 implemented in catheter 40 may be useful within the left atrium for accurately positioning an array of ablation electrodes around the ostia of one or more of the pulmonary veins in order to produce bi-directional conduction block. It is considered necessary to create such block often when treating AF patients using RF ablation to less-invasively emulate the established open heart surgical procedure commonly known as Cox's Maze procedure.

The pre-shaped distal portion 44 in the configuration of FIG. 3B includes a substantially circular or semi-circular loop. The band electrodes 42 deployed at the pre-shaped distal portion are thereby arrayed in a shape that is particularly suited for creating a conduction block in one or more pulmonary veins.

An important advantage provided by an articulating catheter 40 implemented in accordance with the principles of the

present invention concerns a significantly increased lumen space within the catheter **40** which facilitates an increased number of electrical conductors and other catheter elements housed within the catheter **40** in comparison to prior art implementations. By way of example, a catheter **40** configured for ablation applications in accordance with the present invention may employ numerous band electrodes **42** (e.g., 6 or 12 electrodes), each bearing several individually insulated wires for power delivery and temperature measurement. In one such configuration, catheter **40** provides sufficient lumen space to accommodate numerous electrical wires (e.g., typically between 15–30 wires), a pre-shaped member situated at the distal section of catheter **40**, two tendon wires, a steering ribbon, and an anchor band, all while maintaining a catheter outer diameter of 7 French (2.3 mm). Those skilled in the art will readily appreciate that providing sufficient lumen space for such payload presents a significant design challenge, which is solved by implementing a catheter **40** consistent with the principles of the present invention.

Returning to the discussion of FIGS. **3A** and **4A**, FIG. **3A** illustrates an embodiment of catheter **40** in a relaxed configuration. As is depicted in FIG. **3A**, the configuration of catheter **40** in a relaxed state is significantly different from the relaxed configuration of prior art catheter **20** depicted in FIG. **1**.

FIG. **4A** depicts catheter **40** in several steered configurations. For example, the pre-shaped section **44** may be selectively deflected from its relaxed orientation, O_R , about a pivot point defined by proximal deflection section **48**. Pre-shaped section **44** may, for example, be deflected about proximal deflection section **48** in a direction toward the longitudinal axis of the proximal section of catheter **40**, as is depicted at steered orientation, O_1 . Also, the pre-shaped section **44** may be deflected toward and beyond a plane normal to the longitudinal axis of the proximal section of catheter **40**, as is depicted at steered orientation, O_2 .

By way of further example, FIG. **4B** shows steered configurations for an articulated catheter **40** having a distal loop as seen in FIG. **3B**. O_R is a relaxed orientation, and O_1 and O_2 are deflected orientations similar to those orientations described with respect to FIG. **4A**.

As can clearly be seen in FIGS. **4A** and **4B**, the distal portion of catheter **40** may be deflected at selected deflection angles relative to proximal deflection section **48** without significantly altering the predetermined shape of the distal section of catheter **40**. In contrast, the steered configuration of prior art catheter **20** depicted in FIG. **2** illustrates significant alteration of the distal section of prior art catheter **20** in response to deflection forces exerted at the distal end **24** of catheter **20**.

FIG. **5** is an illustration of an embodiment of the present invention in which an anchor region, R_{anch} , is shown to be located distal to a deflection region, R_{deft} , and proximal to a pre-shaped region, R_{shp} . A steering mechanism **56** extends from a proximal section **43** of catheter **40** to an anchor band **52** located at the anchor region, R_{anch} . A pre-shaped member **54** extends from the anchor band **52** through the pre-shaped region, R_{shp} . Preferably, pre-shaped member **54** is secured at the distal tip **46** of catheter **40**. By appropriately actuating steering mechanism **56**, tensile and torquing forces are imparted to anchor band **52** to cause pre-shaped region, R_{shp} , to deflect about the deflection region, R_{deft} , as will be discussed in greater detail hereinbelow.

The pre-shaped region, R_{shp} , takes on a shape consistent with that of pre-shaped member **54**. The pre-formed shape of

the pre-shaped region, R_{shp} , may have any form which generally conforms to the contour of the anatomical feature of interest. For example, the pre-shaped member **54** may have a contour that conforms to a biological cavity containing tissue to be ablated. It is understood that the configuration of pre-shaped region, R_{shp} , has been simplified for purposes of clarity, and that pre-shaped region, R_{shp} , may take various simple and complex forms. For example, the substantially straight portion of the pre-shaped region, R_{shp} , may instead have a simple or complex curved contour that follows that of pre-shaped member **54**. The pre-shaped section, R_{shp} , may, for example, have a form that facilitates treatment of atrial fibrillation in that its shape allows for the distal portion of catheter **40** to be easily inserted into the atrium of the heart. The pre-formed member **54** employed in combination with proximal deflection region, R_{deft} , and steering mechanism **56** provides for a shape-adjustable, steerable distal catheter region having a contour which may be dynamically adjusted during use to conform to the contour of the atrium or other anatomical feature of interest.

Turning now to FIG. **6**, there is illustrated an embodiment of a shape-adjustable catheter **40** employing a proximal steering mechanism in accordance with the principles of the present invention. It is noted that the catheter **40** shown in FIG. **6** is depicted in a linear or straight schematic configuration, without curvature indicated for purposes of clarity. According to this embodiment, catheter **40** is shown to include a proximal section **43**, a deflection section **48**, a pre-shaped section **44**, and a distal tip **46**. The shaft of catheter **40** at the proximal section **43** includes three layers. An outer layer **60** at the proximal section **43** is formed of a high durometer (e.g., 63 Shore D) PEBAX outer jacket having an outside diameter of 0.094 inches or 7 French, and an inside diameter of 0.062 inches. The proximal portion **43** of the sheath of catheter **40** further includes a braid layer **62** formed of eight strands of interwoven stainless steel ribbon, each with 0.001 inch by 0.003 inch cross-section. The braided ribbon **62** has a diameter of 0.009 inches. The braided ribbon **62** stiffens the proximal portion **43** of the catheter shaft, so it minimally deflects under normal steering loads. An inner core of the catheter sheath includes a tube **60** of polyetheretherketone (PEEK), having a diameter of 0.064 inches and an outer diameter of 0.078 inches.

At the distal end of the proximal shaft section **43** resides a flexible compression cage **120** that engages with the PEEK tube **64** and is embedded within low durometer (e.g., 35 Shore D) PEBAX **60a**. The compression cage **120** is preferably formed from nitinol. The sheath section of catheter **40** that includes the compression cage **120** and low durometer PEBAX jacket **60a** defines all or a substantial portion of the deflection region **48** of catheter **40**. The combination of compression cage **120** and low durometer PEBAX jacket **60a** provides for deflection of catheter **40** proximal to an anchor band **52** when tension is applied to a steering tendon connected to anchor band **52**. The compression cage **120**, as will be described in greater detail below, facilitates deflection of the steering portion of catheter **40** relative to a longitudinal axis of catheter **40**, and resists axial compression along the catheters longitudinal axis.

To vary the stiffness of the catheter **40**, the bending properties of either the catheter shaft (e.g., durometer of the polymeric materials) or the pre-shaped section **44** (e.g., the diameter or cross-section of a pre-formed stylet) can be varied along its length. This could be done to tune the relative stiffness of the distal tip region in order to minimize the risk of trauma. Furthermore, to help the distal tip **46** stay in the coronary sinus while the sheath is slid forward, the

pre-shaped section **44** can include a slight bend or “hook” near the distal tip **46** so that the catheter **40** is less likely to slip out of the ostium.

As is further shown in FIG. 6A, an anchor band **52** is installed within at least a portion of the distal of opening of the compression cage **120**. In one configuration, one or two stainless steel tendon wires **76**, best seen in FIGS. 8A and 8B, are pre-affixed to the anchor band **52** prior to installation. One or two steering tendons **76** can be provided depending on whether the catheter **40** will steer in a uni-directional or bi-directional manner. Each steering tendon **76** is substantially enclosed within a lubricious tendon sheath **77**, e.g., PTFE or similar material, that primarily serves to minimize friction between the tendon wire **76** and inner catheter wall. In one configuration, the tendon sheath **77** is bonded or otherwise affixed to the inner catheter wall, and the steering tendon **76** is slidably disposed within the tendon sheath **77**. This serves to restrain the steering tendon **76** from undesired movements (e.g. radial deflections) while allowing the steering tendon **76** to axially slide within the catheter’s sheath. In an alternate configuration, the tendon sheath **76** can be formed as a void in the PEEK tube wall.

It is preferable that the attachment point of the steering tendon(s) **76** to the metallic anchor band **52** be accomplished by welding or soldering. The anchor band **52** may then be embedded within the wall of the catheter during shaft lay-up. Alternatively, the anchor band **52** may be adhered at a later fabrication stage to the inner wall of the catheter shaft, such as by adhesive bonding or by hot melting the shaft material.

Attached to a distal end of the anchor band **52** is a hollow distal jacket section **60b** formed of a low durometer PEBAX material, upon which an array of band electrodes (not shown) can be placed. The distal tip **46** of catheter **40** is typically a metal component that is affixed to the distal end of the PEBAX distal jacket **60b**. The metal component at the distal end **46** of catheter **40** can be platinum, if used for ablation, or less expensive stainless steel, if no ablation is intended.

In one embodiment, the electrodes provided at the distal end of catheter **40** include twelve band electrodes arranged in a substantially linear array along the distal portion of catheter **40**. A tip electrode may also be provided at the distal tip **46** of catheter **40**. The band electrodes may be arranged so that there is space between the adjacent electrodes. In one configuration, the width of the band electrodes is 3 mm and the space between the electrodes is 4 mm. It is understood that the arrangement of band electrodes is not limited to a linear array and may take the form of other patterns. For example, a substantially linear array is preferred for certain therapeutic procedures, such as treatment of atrial fibrillation, in which linear lesions of typically 4–8 cm in length are desired. A linear array is more easily carried by the catheter **40** and also lessens the size of the catheter.

Temperature sensors for monitoring the temperature of the electrodes at various points along the distal portion of catheter **40** may also be provided. In one configuration, each band electrode has a temperature sensor mounted to it. Each temperature sensor provides a temperature signal which is indicative of the temperature of the respective band electrode at that sensor. In another embodiment, a temperature sensor is mounted on every other band electrode. In yet another configuration, every other electrode can have two temperature sensors.

The pre-shaped member **74** is formed of a resilient material capable of retaining a pre-formed shape upon removal of deformation forces acting thereon. The pre-

shaped member **74** is preferably made of superelastic wire or ribbon material so that it readily straightens while being fed into the cardiac anatomy and then readily resumes its original pre-shaped configuration. In general, the configuration of pre-shaped member **74** is selected to approximate a given anatomical requirement. In addition, once the pre-shaped member **74** passes into a biological tissue cavity, such as the right atrium, for example, the shape of the distal portion of catheter **40** resumes its pre-formed configuration.

In the configuration illustrated in FIG. 6A, pre-shaped member **74** represents a stylet that resides within the catheter **40**, and is preferably affixed to the distal tip **46** of catheter **40** to prevent migration of pre-shaped member **74** within the catheter **40** while in use. The pre-shaped member **74** may also be fixably attached to the anchor band **52** by means such as filling the anchor band **52** with an adhesive to trap the pre-shaped member therein. Attaching the pre-shaped member **74** in this way allows more effective torque transmission from the catheter’s proximal shaft to the distal tip **46**. It is noted that the desired pre-shape of the distal-end portion of catheter **40** may alternatively be imparted by heat-setting the polymer catheter shaft material at the distal end of catheter **40**.

In one embodiment, pre-shaped member **74** is formed from superelastic nitinol wire which has been previously heated under constraint to permanently set the intended shape. The superelastic nitinol member, such as a stylet, is held in a fixture and heated to approximately 500° C. for about 15 minutes. The diameter of the nitinol stylet can be varied, such as by grinding, to tailor its bending stiffness where appropriate, such as to soften the distal tip section for minimizing trauma risk.

For simplicity, a pre-shaped stylet **74** can have a round cross-section over most of its length. In principle, however, pre-shaped stylet **74** could have other cross-section, such as a D-shaped, square or rectangular, or other shape depending largely upon the intended pre-shape and its desired bending characteristics. The pre-shaped stylet **74** can also be flattened or tapered where the stylet’s proximal portion forms a joint with steering ribbon **70**. It is appreciated that a single pre-shape will likely not be suitable for all patients. Therefore, it is likely that a family of several different pre-shaped stylets **74** would be available to the physician.

The steering ribbon **70** extends through at least a portion of the proximal section **43** and substantially all of the deflection section **48** of the catheter shaft. The width of steering ribbon **70** is preferably matched to that of the shaft lumen. As is best seen in FIGS. 8A and 8B, steering ribbon **70** has a width such that it contacts diametrically opposed sides of the sheath inner wall, thereby bisecting the lumen of the proximal and deflection sections **43**, **48** of catheter **40**. Sets of electrical wires **72A**, **72B** and are separated from one another by steering ribbon **70**. An equal number of electrical wires **72** are preferably situated on either side of steering ribbon **70**.

A pair of steering tendons **76**, as is further shown in FIGS. 8A and 8B, is separated within the catheter’s lumen by steering ribbon **70**. In the proximal section **43** of the catheter’s lumen, steering tendon(s) **76** are covered with a tendon sheath **77**, such as by a coating of PTFE. It is noted that the steering tendon wire(s) **76** are not sheathed in the particular cross-section shown in FIG. 8B because the tendon(s) **76** are welded directly to the inner wall of the anchor band **52**.

The steering ribbon **70** not only conveniently segregates the electrical wires, but it also forces the steering tendon(s)

76 to always reside along the same side as their attachment point(s) on the anchor band 52. If the later were not so, then it would be possible for the deflectable section 48 to deflect in an unintended direction or assume an unpredictable profile, such as the shape of the “S,” instead of a semicircular arc or other shape that is intended. It is noted that if the steering ribbon 70 were eliminated, then steering profiles could be controlled by permanently affixing each steering tendon sheath 77 to the inner wall of the shaft lumen in order to prevent tendon wire migration. As shown, the steering ribbon 70 is deliberately thin for ease of bending, and preferably made of a resilient material, such as superelastic nitinol, so that it can withstand severe deflections due to steering without permanently deforming.

As is shown in FIGS. 6A and 8B, a proximal end portion of pre-shaped member 74 is joined with a distal-end portion of steering ribbon 70 within anchor band 52. As shown in FIGS. 6A and 8B, a lap joint between the steering ribbon 70 and pre-shaped member 74 is formed within the anchor band 52.

The anchor band 52 can be formed from a stainless steel ring, and is typically affixed to the shaft wall material 60 of catheter 40. Side and front views of anchor band 52 are provided in FIGS. 7A and 7B. Anchor band 52 includes a main cylindrical portion 55 and a number of spaced annular rings or ribs 53. The anchor band 52 may also include one or more weep holes 57 that allow filling the anchor band with an adhesive during assembly. The steering tendon wire(s) 76 is preferably welded or soldered to the inner wall of the anchor band 52. The steering tendon axis is parallel to but offset from the longitudinal axis of the catheter shaft. Pulling the steering tendon 76 causes the shaft to deflect such that the pulled tendon 76 always follows the inside radius of shaft curvature.

To improve torque transmission of the overall catheter assembly, the remaining space within the anchor band 52 may be filled with an adhesive or other filler material, such as epoxy, cyanoacrylate, urethane, or other suitable filler material. Use of such an adhesive as a filler material within anchor band 52 also serves to maintain alignment between the preferred bending planes of the compression cage 120 and steering ribbon 70, thereby assuring steering uniformity.

The deflectable section 48 of catheter 40 is advantageously implemented to deflect in a predictable, selectable manner, while carrying the accompanying axial compressive load whenever a tensile load is applied to a steering tendon 76. Those skilled in the art readily appreciate the difficulty for an ordinary thin-wall deflectable structure to endure deformation forces associated with catheter manipulation without buckling or excessively wrinkling. Catheter 40 implemented in accordance with an embodiment of the present invention employs a compression cage 120 that allows for a desired level of catheter shaft flexibility at the deflection section 48 of catheter 40, while providing the requisite columnar support needed to prevent undesirable buckling due to excessive compressive axial loads.

Turning now to FIGS. 9A–9E, there are illustrated various embodiments of a compression cage 120 in accordance with the principles of the present invention. It is understood that a catheter 40 implemented in accordance with the present invention preferably incorporates compression cage 120 within the catheter structure, but in certain implementations, compression cage 120 may optionally be excluded.

With reference to FIGS. 9A–9E, various configurations of a support system or compression cage 120 are shown. In one configuration, shown in FIG. 9A, the compression cage 120

includes a flat-wire coil 126 and two substantially longitudinal struts 128. The struts 128 are diametrically opposed from each other and are welded, soldered, brazed, adhered, or otherwise attached to some or all loops of the coil 126. In another configuration, shown in FIG. 9B, the compression cage 120 includes a round-wire coil 130 and two substantially longitudinal struts 132. The struts 132 are diametrically opposed from each other and are welded, soldered, brazed, adhered, or otherwise attached to some or all loops of the coil 130.

In another configuration, shown in FIGS. 9C and 9D, the compression cage 120 includes a substantially tubular member 134 with an array of deep notches 136 cut at a pitch angle. The material remaining between opposing notches 136 is thereby formed into a substantially helical structure with connecting struts 138. In yet another configuration, shown in FIG. 9E, the compression cage 120 includes a linear array of rings 140 and two substantially longitudinal struts 142 that interconnect the rings. The struts 142 are diametrically opposed from each other and are welded, soldered, brazed, adhered, or otherwise attached to each of the rings 140.

The primary function of the struts 128, 132, 138, 142 is to provide columnar strength to the compression cage 120. When a tensile load is applied to a steering tendon 76 to induce deflection of the distal-end region 44 of catheter 40, the reaction to the load is carried by the struts 128, 132, 138, 142 within the compression cage 120 and transferred into the relatively rigid proximal region 43 of catheter 40. The compression cage 120 deflects laterally most easily in a direction that is perpendicular to the plane in which a pair of opposing struts 128, 132, 138, 142 are located.

The support system 120 and anchor band 52 can be attached to the inner surface of the sheath within the deflection region 48, such as by melt-bonding, use of adhesives, or some other mechanical means. In an alternate and particularly useful configuration, the support system 120 is embedded within the walls of the sheath. Embedding the support system 120 within the catheter sheath serves to maximize the lumen diameter because there is only one “composite” wall having reduced thickness relative to the combined thickness that would result if the support system 120 were attached to an inner surface of the sheath walls.

The proximal end of the embedded support system 120 can be attached to the catheter using a union 146, best seen in FIG. 9C. An enlarged end of the union 146 fits over the distal end of the PEEK tube 64, and the narrowed end of the union 146 fits inside the support structure 120. The union 146 helps ensure that axial compressive loads carried by the support structure are reliably transferred to the proximal region 43 of the catheter sheath.

A tensile load produced by axial translation of a steering tendon 76 in the proximal direction causes the deflection region 48 to compress in the area of the support system 120 and to stretch in the area distal the support system 120. However, as previously mentioned, the reaction to the tensile load is carried by the struts 128, 132, 138, 142 within the support system 120 and is transferred into the relatively rigid proximal region 43 of the catheter sheath, thereby minimizing the associated compression and stretching of the deflection region 48 of the catheter sheath.

The support system 120 and other elements of catheter 40 described hereinabove may be configured as described in commonly owned U.S. patent application Ser. No. 09/848, 087, filed on May 2, 2001 under Attorney Docket No. HRT-55403 and entitled “Steerable Catheter with Shaft

Support System for Resisting Axial Compressive Loads”, U.S. patent application Ser. No. 09/848,114, filed on May 2, 2001 under Attorney Docket No. HRT-55404 and entitled “Steerable Catheter with Torque Transfer System”, and commonly owned U.S. Pat. Nos. 6,270,496 and 6,096,036, all of which are hereby incorporated herein by reference in their respective entireties.

As was discussed previously, a catheter **40** of the present invention may be employed in a variety of applications. In a configuration in which catheter **40** is implemented as an EP diagnostic catheter, catheter **40** is typically fed through a guiding catheter or introducer sheath and placed within the right atrium. The electrical leads from mapping electrodes located at the distal-end region of catheter **30** can be connected to an ECG monitor, and the ECG waveforms from adjacent electrode pairs can be examined. Since the proportion of atrial (“A”) signal relative to ventricular (“V”) signal changes progressively throughout the atrium, ECG waveforms can be used to home in on the location of the coronary sinus ostium. It is noted that the coronary sinus resides in a region where the “A” and “V” signals are approximately equal in strength. Using both ECG and fluoroscopy feedback, the distal end of the EP diagnostic catheter **40** of the present invention would be readily manipulated into the coronary sinus, and then the guiding catheter or sheath would be made to track over the EP diagnostic catheter **40** and “deep seated” within the coronary sinus. If the sheath were equipped with an occlusion balloon, it could then be inflated to anchor it in place while the EP diagnostic catheter **40** is removed. At this point, an angiogram would typically be performed followed by implantation of a pacing lead.

An important advantage associated with the present invention is that CHF implant procedure times presently vary widely, and that an EP diagnostic catheter **40** of the present invention could be used as a “frontline” device to make the procedure more predictable. Instead of the present situation where the clinician is left to his own devices if the pre-shaped guide or sheath fails to locate the coronary sinus, the catheter **40** of the present invention in conjunction with a non-shaped guide or sheath would provide a consistent, reliable means of quickly locating the coronary sinus.

In another configuration, a catheter **40** according to the present invention can be employed as an ablation catheter. A particularly useful ablation treatment for patients with atrial fibrillation involves ablating tissue around a pulmonary vein orifice. This procedure, known as circumferential RF ablation, can be used to isolate the pulmonary veins from the left atrium. The procedure involves introducing the ablation catheter **40** into the left atrium, typically via transseptal catheterization. Proper catheter location within the left atrium can be confirmed by fluoroscopy or advanced ultrasonic means. Ablation is preferably performed by applying a combination of bipolar (band electrode to band electrode) and unipolar (band electrode to backplate, e.g., cutaneous ground patch) potential differences. These potential differences can be applied using multiphase RF energy delivery as well as sequential unipolar/bipolar RF delivery. The resulting unipolar and bipolar currents promote both lesion depth and lesion fill-in between band electrodes.

It will, of course, be understood that various modifications and additions can be made to the preferred embodiments discussed hereinabove without departing from the scope of the present invention. Accordingly, the scope of the present invention should not be limited by the particular embodiments described above, but should be defined only by the claims set forth below and equivalents thereof.

What is claimed is:

1. A catheter, comprising:
 - a sheath including a proximal region, a deflection region, a distal-end region including a shaped region, an anchor region defined between the deflection region and the shaped region, and a longitudinal axis;
 - a shaped member extending from the shaped region of the sheath to at least a portion of the anchor region, the shaped region of the sheath deformable to a shape substantially that of the shaped member;
 - a steering ribbon extending from the proximal region of the sheath and passing within at least a portion of the anchor region, a distal end of the steering ribbon joined with a proximal portion of the shaped member; and
 - at least one steering tendon disposed within the sheath, the steering tendon having a first end attached at the anchor region and a second end located at the proximal region of the sheath, wherein movement of the steering tendon in a proximal direction causes the deflection region to deflect relative to the longitudinal axis while the shape of the shaped region of the sheath is substantially maintained.
2. The catheter of claim 1, wherein the shaped member is shaped to facilitate movement of the catheter relative to a specified anatomical feature.
3. The catheter of claim 1, wherein the shaped member comprises a resilient material having a pre-formed configuration, such that the pre-formed configuration of the shaped member is deformable to a substantially straightened configuration to facilitate movement of the catheter through vasculature, the shaped member returning to the pre-formed configuration when unconstrained by the vasculature.
4. The catheter of claim 1, wherein the shaped member comprises a pre-formed outer portion of the sheath.
5. The catheter of claim 1, wherein the shaped member comprises a stylet having a pre-established shape.
6. The catheter of claim 1, wherein the shaped member is secured to a distal end of the catheter.
7. The catheter of claim 1, wherein the proximal portion of the shaped member is joined to the distal portion of the steering ribbon by a weld, a solder joint, or an adhesive to form a lap joint.
8. The catheter of claim 1, wherein the anchor region comprises an anchor band within which a distal portion of the steering ribbon and the proximal portion of the shaped member are joined.
9. The catheter of claim 8, wherein the steering tendon is connected to a location of the anchor band offset from the longitudinal axis of the sheath.
10. The catheter of claim 9, wherein a plurality of electrical conductors pass through the anchor band.
11. The catheter of claim 1, wherein a filler material substantially fills voids within the anchor band.
12. The catheter of claim 1, further comprising a support structure extending over all or a portion of the deflection region, the support structure configured to deflect laterally relative to the longitudinal axis and to resist axial compression along the longitudinal axis of the sheath.
13. The catheter of claim 12, wherein the support system is formed of a superelastic material.
14. The catheter of claim 12, wherein the support system comprises a substantially tubular member comprising an array of notches.
15. The catheter of claim 12, wherein the support system comprises a linear array of apertured rings defining a lumen, and at least one strut secured to one side of each of the rings.
16. The catheter of claim 15, wherein the support system comprises a pair of struts secured to diametrically opposite sides of each of the rings.

15

17. The catheter of claim 1, wherein the steering ribbon is formed from a resilient material and has a flattened shape.

18. The catheter of claim 1, wherein the steering ribbon has a width sufficient to contact an inner surface of the sheath at two diametrically opposite locations of the sheath's inner surface.

19. The catheter of claim 1, wherein the steering ribbon is integrally formed with the shaped member.

20. The catheter of claim 1, wherein the at least one steering tendon comprises first and second steering tendons, and wherein the steering ribbon separates the first and second steering tendons.

21. A catheter, comprising:

a sheath having a proximal region, a distal-end region, and a deflection region defined between the proximal and distal-end regions;

an anchor band located between the deflection region and the distal-end region;

a shaped member extending from the distal-end region to at least a portion of the anchor band, at least a portion of the distal-end region of the sheath deformable to a shape substantially that of the shaped member;

a steering ribbon extending from the proximal region of the sheath and passing within at least a portion of the anchor band, a distal end of the steering ribbon joined with a proximal portion of the shaped member;

a support structure extending over all or a portion of the deflection region, the support structure configured to deflect laterally relative to a longitudinal axis of the sheath and to resist axial compression along the longitudinal axis; and

at least one steering tendon disposed within the sheath, the steering tendon having a first end attached to the anchor band and a second end located at the proximal region of the sheath, wherein movement of the steering tendon in a proximal direction causes the deflection region to deflect relative to the longitudinal axis while the shape of the shaped member is substantially maintained.

22. The catheter of claim 21, further comprising at least one electrode located at a distal-end tip of the sheath.

23. The catheter of claim 21, further comprising a plurality of electrodes located at one or both of the distal-end and deflection regions for sensing cardiac signals or for transferring energy to biological tissue.

24. The catheter of claim 21, wherein the shaped member comprises a resilient material having a pre-formed configuration, such that the pre-formed configuration of the shaped member is deformable to a substantially straightened configuration to facilitate movement of the catheter through vasculature, the shaped member returning to the pre-formed configuration when unconstrained by the vasculature.

25. The catheter of claim 21, wherein the shaped member comprises a pre-formed outer portion of the sheath.

26. The catheter of claim 21, wherein the shaped member comprises a stylet having a pre-established shape.

27. The catheter of claim 21, wherein the proximal portion of the shaped member is joined to the distal end of the steering ribbon to form a lap joint.

28. The catheter of claim 21, wherein the support system is formed of a superelastic material.

29. The catheter of claim 21, wherein the support system comprises a substantially tubular member comprising an array of notches.

30. The catheter of claim 21, wherein the support system comprises a linear array of apertured rings defining a lumen, and at least one strut secured to one side of each of the rings.

16

31. The catheter of claim 30, wherein the support system comprises a pair of struts secured to diametrically opposite sides of each of the rings.

32. The catheter of claim 21, wherein the steering ribbon is formed from a resilient material and has a flattened shape.

33. The catheter of claim 21, wherein the steering ribbon has a width sufficient to contact an inner surface of the sheath at two diametrically opposite locations of the sheath's inner surface.

34. The catheter of claim 21, wherein the steering ribbon is integrally formed with the shaped member.

35. The catheter of claim 21, wherein the at least one steering tendon comprises first and second steering tendons, and wherein the steering ribbon separates the first and second steering tendons.

36. A catheter, comprising:

a sheath including a proximal region, a deflection region, a distal-end region including a shaped region, an anchor region defined between the deflection region and the shaped region, and a longitudinal axis;

a shaped member extending from the shaped region of the sheath to at least a portion of the anchor region, the shaped member fixably attached to the anchor region, the shaped region of the sheath deformable to a shape substantially that of the shaped member; and

at least one steering tendon slidably disposed within the sheath, the steering tendon having a first end attached at the anchor region and a second end located at the proximal region of the sheath, wherein movement of the steering tendon in a proximal direction causes the deflection region to deflect relative to the longitudinal axis while the shape of the shaped region of the sheath is substantially maintained.

37. The catheter of claim 36, further comprising at least one electrode located at a distal-end tip of the sheath.

38. The catheter of claim 36, further comprising a plurality of electrodes located at one or both of the distal-end and deflection regions for sensing cardiac signals or for transferring energy to biological tissue.

39. The catheter of claim 36, wherein the shaped member comprises a resilient material having a pre-formed configuration, such that the pre-formed configuration of the shaped member is deformable to a substantially straightened configuration to facilitate movement of the catheter through vasculature, the shaped member returning to the pre-formed configuration when unconstrained by the vasculature.

40. The catheter of claim 36, wherein the shaped member comprises a pre-formed outer portion of the sheath.

41. The catheter of claim 36, wherein the shaped member comprises a stylet having a pre-established shape.

42. A catheterization device, comprising:

a catheter comprising a proximal region, a pre-formed region at a distal end of the catheter, a deflection mechanism proximal to the pre-formed region, a deflection region proximal to the deflection mechanism, and a longitudinal axis;

means for applying an axial force in a proximal direction to the deflection mechanism, the axial force causing the deflection region to deflect relative to a longitudinal axis of the proximal region of the catheter while a pre-formed shape of the pre-formed region is substantially maintained; and

means for resisting axial compression along the longitudinal axis at the deflection region resulting from application of the axial force.

43. The device of claim 42, further comprising means for deforming the pre-formed region to a substantially straight-

17

ened configuration to facilitate movement of the catheter through vasculature, and means for resuming the pre-formed region to the pre-formed shape when unconstrained by the vasculature.

44. The device of claim 42, further comprising means for axial force to the deflection mechanism to change a bend angle at the deflection region while the pre-formed shape of the pre-formed region is substantially maintained.

18

45. The device of claim 42, further comprising means for sensing cardiac signals at the pre-formed region of the catheter.

46. The device of claim 42, further comprising means for delivering energy from the pre-formed region of the catheter to cardiac tissue.

* * * * *

专利名称(译)	具有近端关节和预成形远端的预成形导管		
公开(公告)号	US6869414	公开(公告)日	2005-03-22
申请号	US10/105087	申请日	2002-03-22
[标]申请(专利权)人(译)	SIMPSON约翰 HAYZELDEN ROBERTÇ BOWE韦德		
申请(专利权)人(译)	JOHN SIMPSON A. HAYZELDEN罗伯特C. BOWE WADE A.		
当前申请(专利权)人(译)	心脏起搏器, INC.		
[标]发明人	SIMPSON JOHN A HAYZELDEN ROBERT C BOWE WADE A		
发明人	SIMPSON, JOHN A. HAYZELDEN, ROBERT C. BOWE, WADE A.		
IPC分类号	A61M25/00 A61M31/00 A61M37/00 A61B5/00		
CPC分类号	A61M25/0041 A61M25/0138 A61M25/0152 A61M25/0147 A61M2025/0163 A61M2025/0161		
其他公开文献	US20030181855A1		
外部链接	Espacenet USPTO		

摘要(译)

导管采用预先形成的远端和近端偏转机构来操纵导管。成形构件从导管鞘的成形区域延伸到锚固区域的至少一部分。转向带从护套的近端区域延伸并且在锚固区域的至少一部分内通过。转向带的远端与成形构件的近端部分连接。至少一个转向肌腱设置在护套内并且具有连接在锚固区域的第一端和位于护套的近端区域的第二端。转向肌腱在近端方向上的运动导致偏转区域相对于导管的纵向轴线偏转,同时基本上保持护套的成形区域的形状。

