



US006602246B1

(12) **United States Patent**  
**Joye et al.**

(10) **Patent No.:** **US 6,602,246 B1**  
(45) **Date of Patent:** **Aug. 5, 2003**

(54) **CRYOTHERAPY METHOD FOR  
DETECTING AND TREATING VULNERABLE  
PLAQUE**

(75) Inventors: **James Joye**, Los Gatos, CA (US);  
**Kristine Tatsutani**, Oakland, CA (US)

(73) Assignee: **Cryovascular Systems, Inc.**, Los  
Gatos, CA (US)

(\*) Notice: Subject to any disclaimer, the term of this  
patent is extended or adjusted under 35  
U.S.C. 154(b) by 0 days.

(21) Appl. No.: **09/641,462**

(22) Filed: **Aug. 18, 2000**

(51) **Int. Cl.**<sup>7</sup> ..... **A61B 18/18**

(52) **U.S. Cl.** ..... **606/21; 606/22; 606/20**

(58) **Field of Search** ..... 606/21, 20, 7,  
606/13, 14, 22

(56) **References Cited**

**U.S. PATENT DOCUMENTS**

3,901,241 A	8/1975	Allen, Jr. ....	128/303.1
4,336,691 A	6/1982	Burstein et al. ....	62/64
4,754,752 A	7/1988	Ginsburg et al. ....	128/303.12
5,019,075 A	5/1991	Spears et al. ....	606/7
5,041,089 A	8/1991	Mueller et al. ....	604/96
5,078,713 A	1/1992	Varney ..... ..	606/23
5,092,841 A	3/1992	Spears ..... ..	604/96
5,106,360 A	4/1992	Ishiwara et al. ....	600/2
5,147,355 A	9/1992	Friedman et al. ....	606/23
5,151,100 A	9/1992	Abele et al. .... ..	606/28
5,190,539 A	3/1993	Fletcher et al. ....	606/25
5,191,883 A	3/1993	Lennox et al. ....	128/401
5,196,024 A	3/1993	Barath ..... ..	606/191
5,275,595 A	1/1994	Dobak, III ..... ..	606/23
5,458,612 A	10/1995	Chin ..... ..	606/192
5,486,208 A	1/1996	Ginsburg ..... ..	607/106
5,501,681 A	3/1996	Neuwirth et al. ....	606/21
5,545,195 A	8/1996	Lennox et al. ....	607/105
5,617,739 A	4/1997	Little ..... ..	62/619
5,644,502 A	7/1997	Little ..... ..	364/496

5,733,280 A	3/1998	Avitall ..... ..	606/23
5,868,735 A *	2/1999	Lafontaine ..... ..	606/21
5,899,899 A	5/1999	Arless et al. ....	
5,902,299 A	5/1999	Jayaraman ..... ..	
5,924,997 A *	7/1999	Campbell ..... ..	600/549
5,971,979 A	10/1999	Joye et al. .... ..	606/21
6,245,026 B1 *	6/2001	Campbell et al. ....	600/549
6,290,696 B1	9/2001	Lafontaine ..... ..	

**FOREIGN PATENT DOCUMENTS**

WO	WO 91/05528	5/1991	.....	A61F/7/12
WO	WO 98/38934	11/1998	.....	A61B/17/39
WO	WO 01/64145 A1	9/2001		
WO	WO 02/04042 A2	1/2002		
WO	WO 02/07625 A2	1/2002		
WO	WO 02/38065 A1	5/2002		

**OTHER PUBLICATIONS**

Casscells, W., et al., *The Vulnerable Atherosclerotic Plaque: Understanding, Identification, and Modification: Chapter 13: Thermography*. Armonk, NY: Futura Publishing Company, Inc.; ©1999. pp. 231-242.

(List continued on next page.)

*Primary Examiner*—Linda C. M. Dvorak

*Assistant Examiner*—Pete J Vrettakos

(74) *Attorney, Agent, or Firm*—Townsend Townsend & Crew LLP; Mark D. Barrish, Esq.

(57) **ABSTRACT**

The present invention provides methods, apparatus, and kits for detection and/or treatment of vulnerable plaque of a blood vessel having a lumen surface. Detection methods include sensing a temperature differential along a lumen surface with temperature sensors that thermally couple the lumen surface. Treatment methods include controlled and safe cryogenic cooling of vulnerable plaque to inhibit release of retained fluid within the vulnerable plaque so as to inhibit acute coronary syndrome and to help maintain patency of a body lumen. Treatment methods may include additional treatments, such as primary treatments or passivation.

**16 Claims, 10 Drawing Sheets**

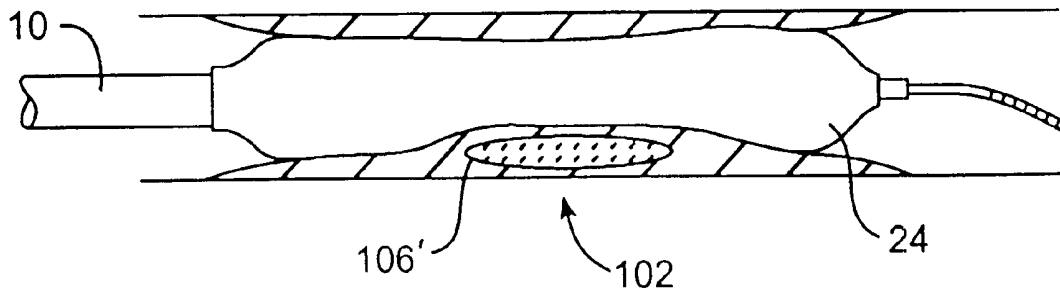

## OTHER PUBLICATIONS

Dalager-Pedersen, S., et al. *The Vulnerable Atherosclerotic Plaque: Understanding, Identification, and Modification: Chapter 1: Coronary Artery Disease: Plaque Vulnerability, Disruption, and Thrombosis*. Armonk, NY: Futura Publishing Company, Inc.; ©1999. pp. 1-23.

Diamantopoulos, L., et al. <http://www.eurekalert.org/releases/aha-ati0041499.html>. "Artery Temperatures Identify Hot Spots on Plaque that May Rupture and Trigger Heart Attack." (Release date: Apr. 20, 1999) 3 pages.

Kruuv, Jack. "Survival of Mammalian Cells Exposed to Pure Hypothermia in Culture." *Advances in Molecular and Cell Biology*. (1997) 9:143-190.

Quinn, P.J. "A Lipid-Phase Separation Model of Low-Temperature Damage to Biological Membranes." *Cryobiology*. (1985) 22:128-146.

Taylor, Michael J. *Biology of Cell Survival in the Cold*. Organ Recovery Systems, Inc. & Allegheny University of Health Sciences. Greenwich, CT: JAI Press, 1996:1-64.

U.S. patent application No. 09/203,011 filed on Dec. 1, 1998 entitled: *Apparatus and Method for Cryogenic Inhibition of Hyperplasia*, Inventor(s): James Joye et al.

U.S. patent application No. 09/344,177 filed on Jun. 24, 1999 entitled: *Cryosurgical Catheter Inhibition of Hyperplasia*, Inventor(s): James Joye et al.

U.S. patent application No. 09/510,903 filed on Feb. 23, 2000 entitled: *Cryogenic Angioplasty Catheter*, Inventor(s): James Joye et al.

U.S. patent application No. 09/511,191 filed on Feb. 23, 2000 entitled: *Cryogenic Angioplasty Catheter*, Inventor(s): James Joye et al.

U.S. patent application No. 09/268,205 filed Mar. 15, 1999 entitled: *Cryosurgical Fluid Supply*, Inventor(s): James Joye et al.

U.S. patent application No. 09/619,583 filed on Jul. 19, 2000 entitled: *Improved Safety Cryotherapy Catheter*, Inventor(s): James Joye et al.

\* cited by examiner

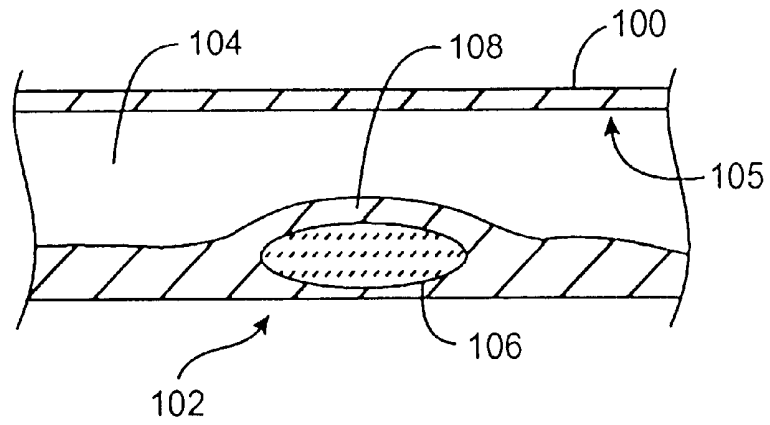

FIG. 1A

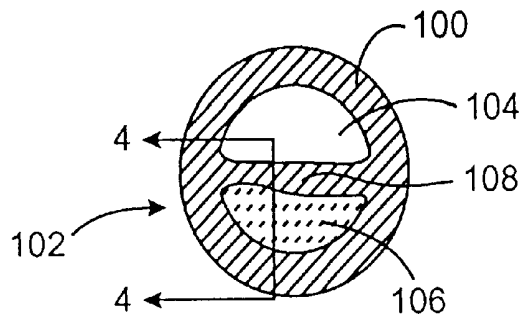

FIG. 1B

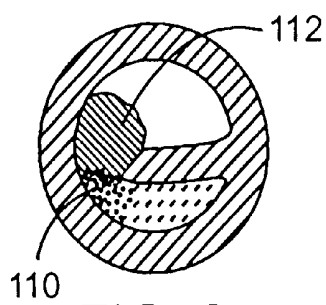

FIG. 2

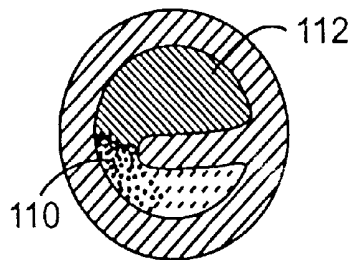

FIG. 3

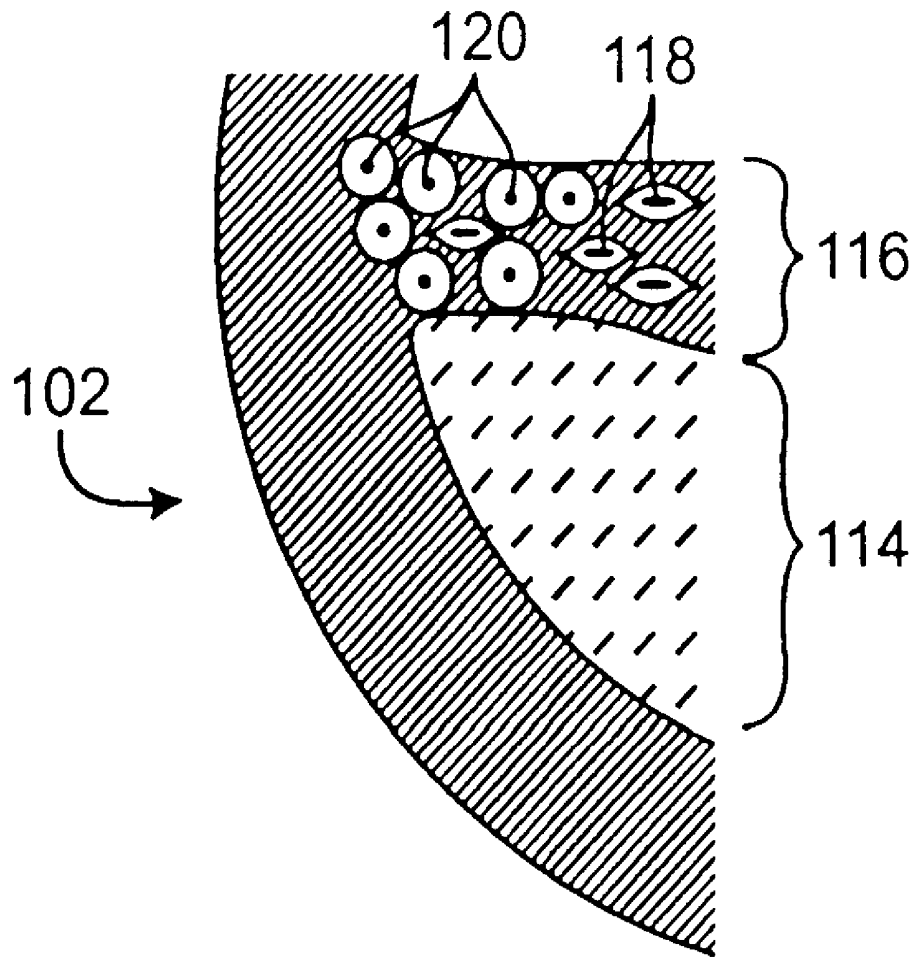

FIG. 4

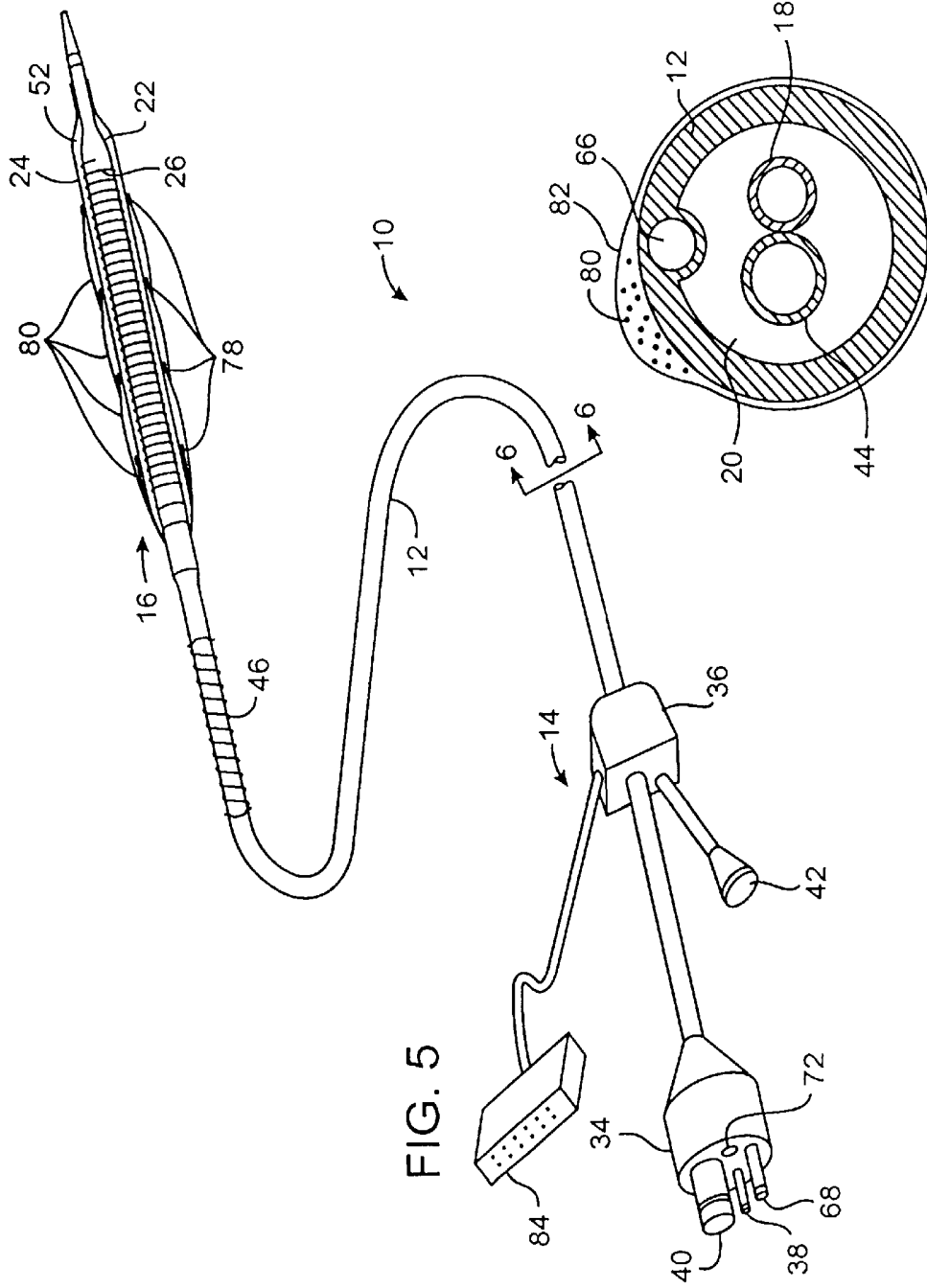

FIG. 5

FIG. 6



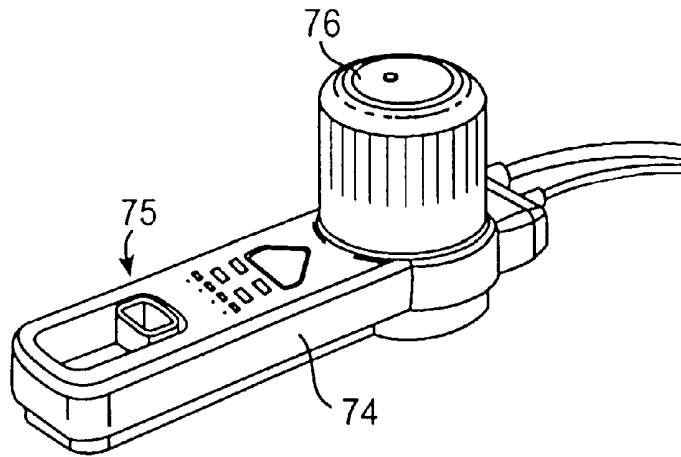

FIG. 8A

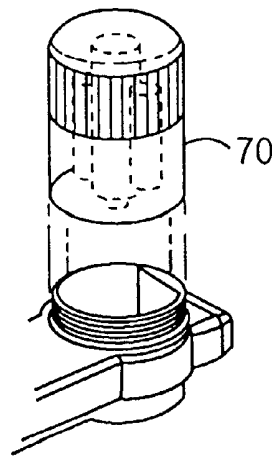

FIG. 8B

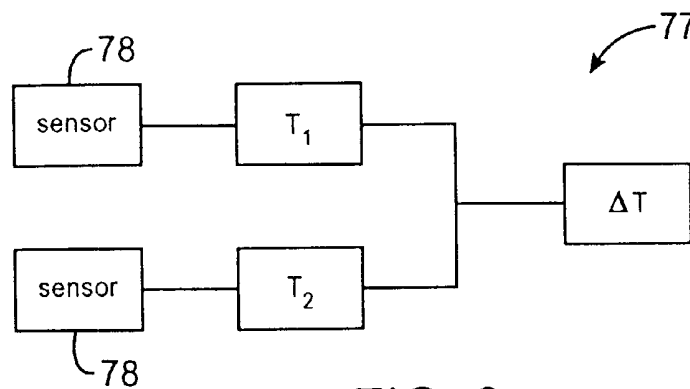

FIG. 9

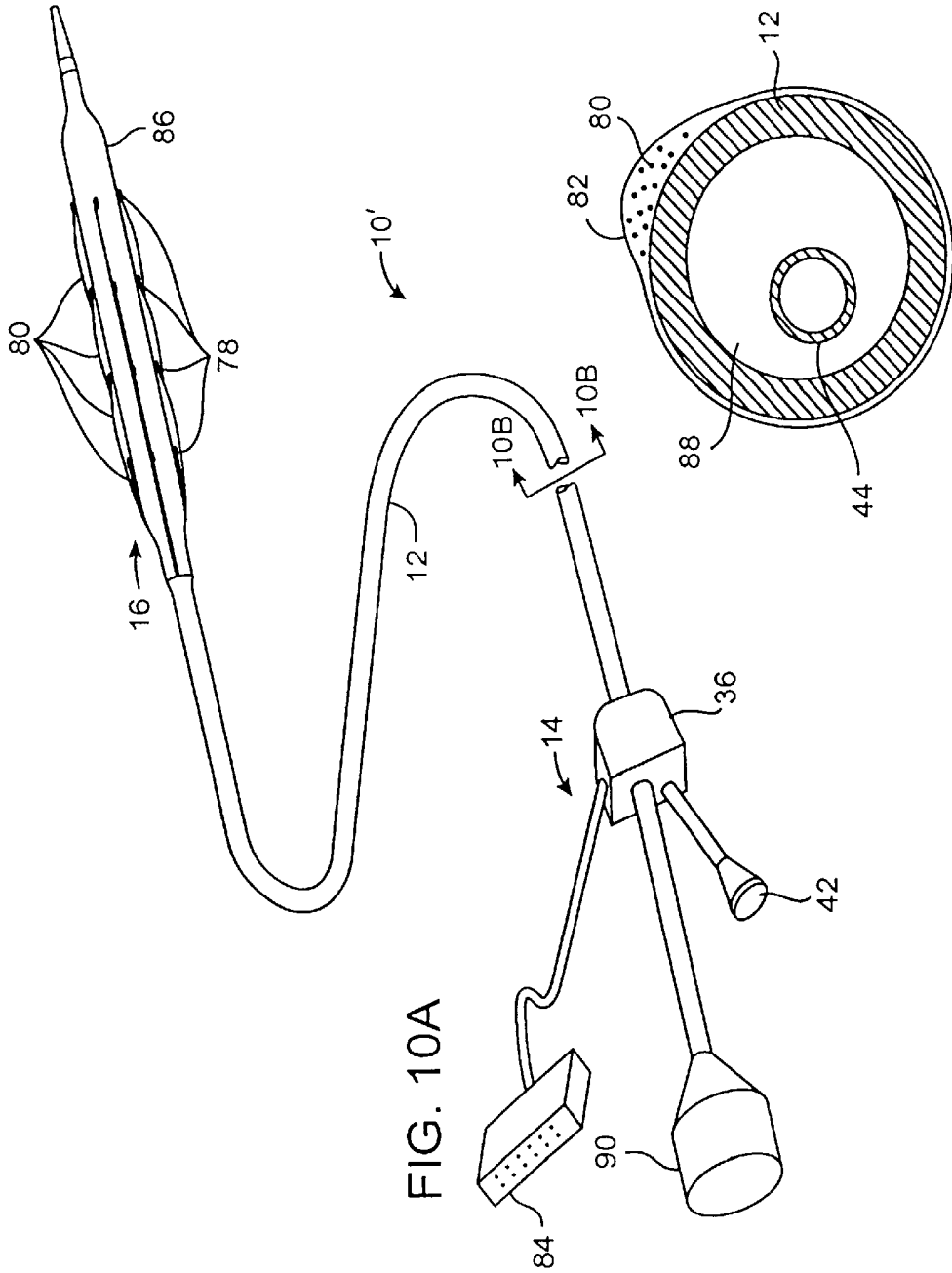

FIG. 10A

FIG. 10B

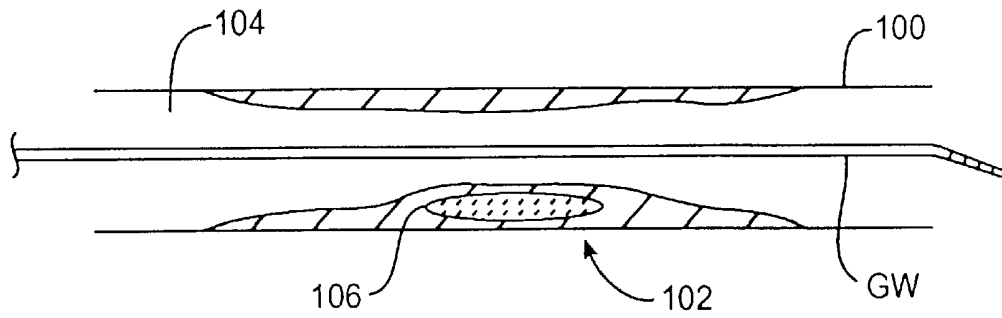

FIG. 11A

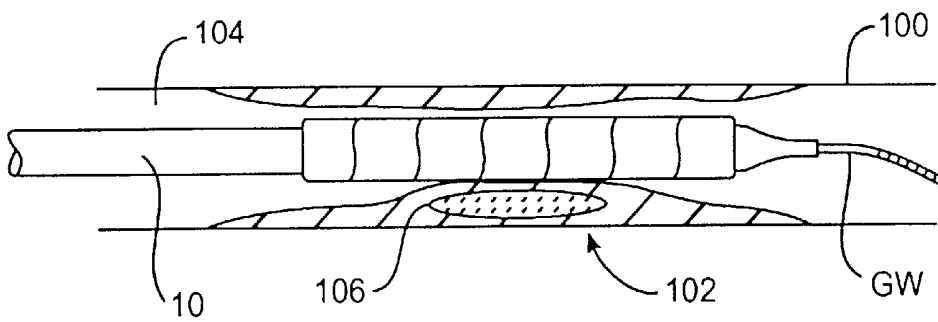

FIG. 11B

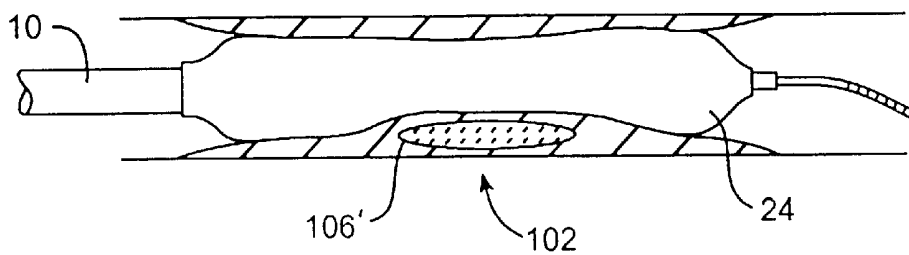

FIG. 11C

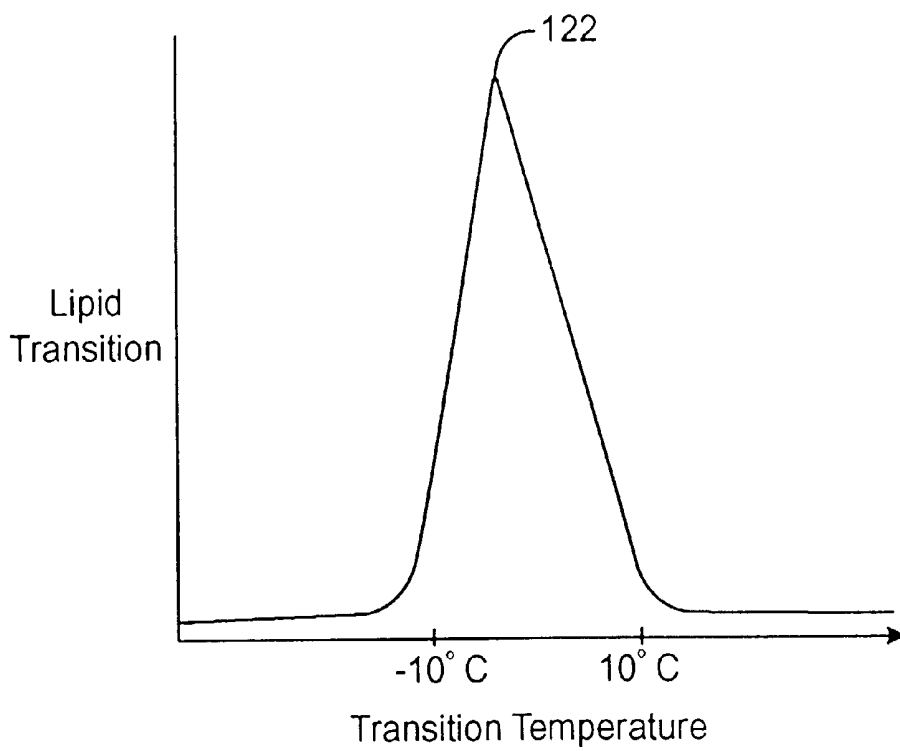

FIG. 12A

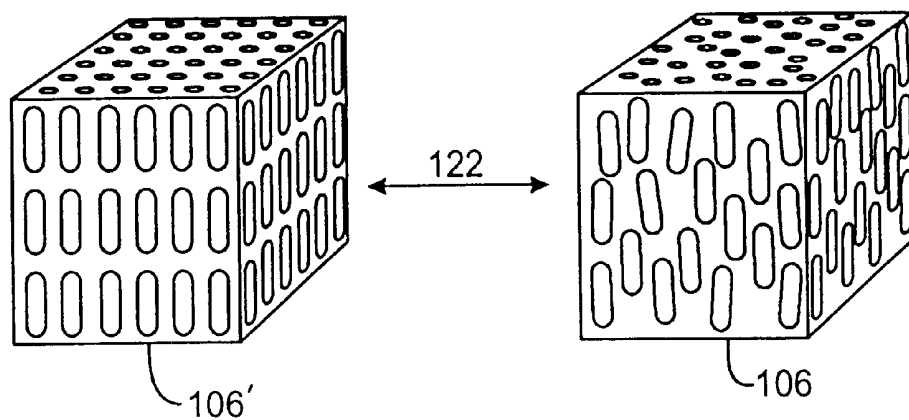

FIG. 12B

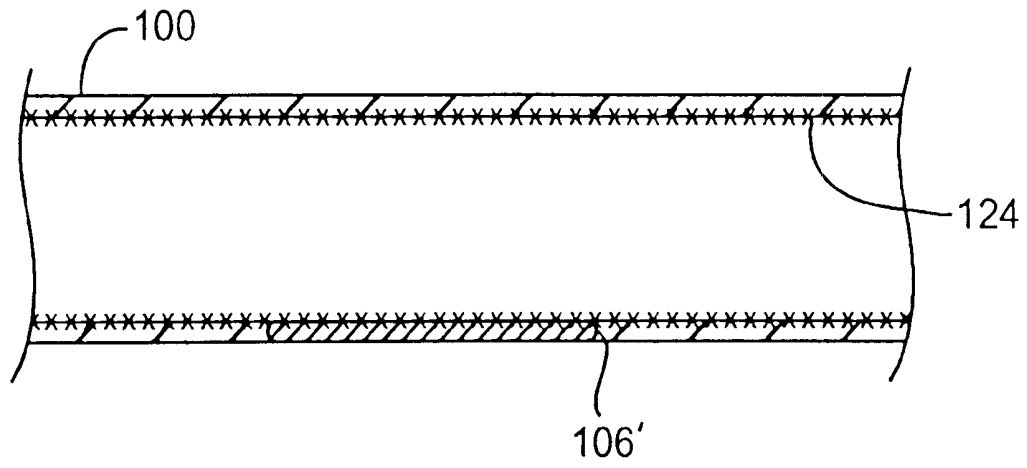

FIG. 13A

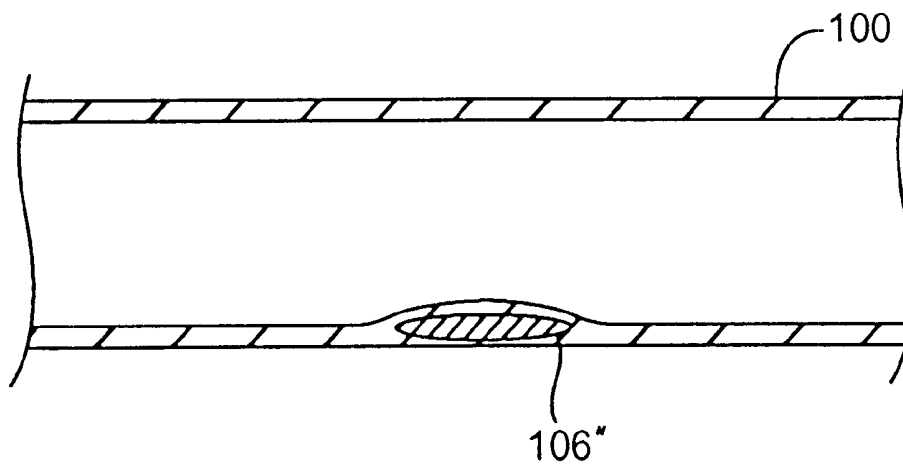

FIG. 13B

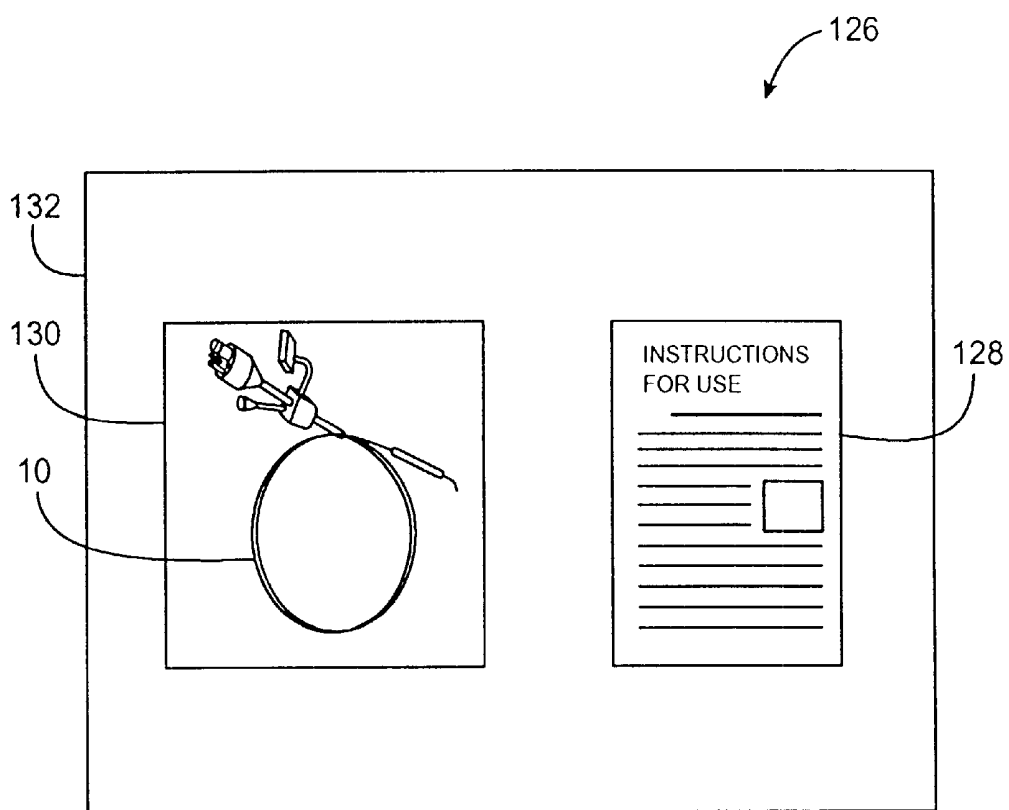

FIG. 14

## CRYOTHERAPY METHOD FOR DETECTING AND TREATING VULNERABLE PLAQUE

### BACKGROUND OF THE INVENTION

#### 1. Field of the Invention

The present invention relates generally to methods, apparatus, and kits for treating blood vessels. More particularly, the present invention provides methods, apparatus, and kits for treating a lesion, and particularly a vulnerable atherosclerotic plaque, within a patient's vasculature to inhibit harmful releases within the vasculature, such as those which may be responsible for strokes or acute coronary syndromes of unstable angina, myocardial infarction, and sudden cardiac death.

Atherosclerotic plaque is present to some degree in most adults. Plaques can severely limit the bloodflow through a blood vessel by narrowing the open vessel lumen. This narrowing effect or stenosis is often responsible for ischemic heart disease. Fortunately, a number of percutaneous intravascular procedures have been developed for treating atherosclerotic plaque in a patient's vasculature. The most successful of these treatments is percutaneous transluminal angioplasty (PTA). PTA employs a catheter having an expandible distal end, usually in the form of an inflatable balloon, to dilate a stenotic region in the vasculature to restore adequate blood flow beyond the stenosis. Other procedures for opening stenotic regions include directional atherectomy, laser angioplasty, stents, and the like. Used alone or in combination, these percutaneous intravascular procedures have provided significant benefits for treatment of stenoses caused by plaque.

While treatments of plaque-induced stenoses have advanced significantly over the last few decades, the morbidity and mortality associated with vascular plaques have remained significant. Recent work suggests that plaque may generally fall into one of two different general types: standard stenotic plaques and vulnerable plaques. Stenotic plaque, which is sometimes referred to as thrombosis-resistant plaque, can generally be treated effectively by the known intravascular lumen opening techniques mentioned above. Although the stenoses they induce may require treatment, these atherosclerotic plaques themselves are often a benign and effectively treatable disease.

Unfortunately, as plaque matures, narrowing of a blood vessel by a proliferation of smooth muscle cells, matrix synthesis, and lipid accumulation may result in formation of a plaque which is quite different than a standard stenotic plaque. Such atherosclerotic plaque becomes thrombosis-prone, and can be highly dangerous. This thrombosis-prone or vulnerable plaque may be a frequent cause of acute coronary syndromes.

The characterization of these vulnerable (and potentially life-threatening) plaques is currently under investigation. A number of strategies have been proposed to detect a vulnerable plaque. Proposed strategies include angiography, intravascular ultrasound, angioscopy, magnetic resonance imaging, magnetic resonance diffusion imaging; spectroscopy, infrared spectroscopy, scintigraphy, optical coherence tomography, electron beam computed tomographic scanning, and thermography, all of which have had limited success. In particular, proposed thermography methods detect temperature variations, as vulnerable plaque is typically inflamed and as such gives off more heat than standard stenotic plaque. While current thermography meth-

ods show great promise, they continue to suffer from limited temperature sensitivity which may often result in inaccurate detections of vulnerable plaque.

While the known procedures for treating plaque have gained wide acceptance and shown good efficacy for treatment of standard stenotic plaques, they may be ineffective (and possibly dangerous) when thrombotic conditions are superimposed on atherosclerotic plaques. Specifically, mechanical stresses caused by primary treatments like PTA or stenting may actually trigger release of fluids and/or solids from a vulnerable plaque into the blood stream, thereby potentially causing a coronary thrombotic occlusion.

For these reasons, it would be desirable to provide methods, apparatus, and kits for the detection and treatment of vulnerable plaque in blood vessels. The methods and apparatus should be suitable for intravascular and intraluminal introduction, preferably via a percutaneous approach. It would be particularly desirable if the new methods and apparatus were able to detect the vulnerable plaque accurately and/or deliver the treatment in a very controlled and safe manner, with minimal deleterious effects on adjacent tissues. Treatment methods, apparatus, and kits should further be effective in inhibiting release of the vulnerable plaque with minimum side effects. At least some of these objectives will be met by the invention described herein.

#### 2. Description of the Background Art

A cryoplasty device and method are described in WO 98/38934. Balloon catheters for intravascular cooling or heating a patient are described in U.S. Pat. No. 5,486,208 and WO 91/05528. A cryosurgical probe with an inflatable bladder for performing intrauterine ablation is described in U.S. Pat. No. 5,501,681. Cryosurgical probes relying on Joule-Thomson cooling are described in U.S. Pat. Nos. 5,275,595; 5,190,539; 5,147,355; 5,078,713; and 3,901,241. Catheters with heated balloons for post-angioplasty and other treatments are described in U.S. Pat. Nos. 5,196,024; 5,191,883; 5,151,100; 5,106,360; 5,092,841; 5,041,089; 5,019,075; and 4,754,752. Cryogenic fluid sources are described in U.S. Pat. Nos. 5,644,502; 5,617,739; and 4,336,691. The following U.S. Patents may also be relevant to the present invention: U.S. Pat. Nos. 5,458,612; 5,545,195; and 5,733,280.

Thermography is described by Ward Casscells et al. in *The Vulnerable Atherosclerotic Plaque: Understanding, Identification, and Modification*, chpt. 13, pp. 231-242 (1999); and L. Diamantopoulos et al. at <http://www.eurekalert.org/releases/aha-ati041499.html>. The impact of low temperatures on lipid membranes is described by Jack Kruuv in *Advances in Molecular and Cell biology*, vol. 19, pp. 143-192 (1997); P.J. Quinn in *Cryobiology*, vol. 22, pp. 128-146 (1985); and Michael J. Taylor, Ph.D. in *Biology Of Cell Survival In The Cold*, (Harwood Academic Publishers, In Press).

The full disclosures of each of the above references are incorporated herein by reference.

### SUMMARY OF THE INVENTION

The present invention provides detection and cryotherapy treatment of vulnerable plaque within a blood vessel of a patient. The blood vessel may be any blood vessel in the patient's vasculature, including veins, arteries, and particularly coronary arteries. The vessel will typically be partially stenosed, at least in part from vulnerable plaque. In particular, the present invention may inhibit release of retained fluid within the vulnerable plaque so as to inhibit acute coronary syndrome and to help maintain the patency

of a body lumen. The present invention may also provide for the treatment of vulnerable plaque in carotid arteries for stroke prevention. Where the patient's vasculature has both the vulnerable plaque and standard stenotic plaque, the treatment techniques described herein may be selectively directed to the vulnerable plaque, optionally without substantial cooling of the standard stenotic plaque. In other embodiments, both types of plaque may be treated.

In a first aspect, the present invention provides a method for treating vulnerable plaque of a blood vessel. The method comprises cooling the blood vessel adjacent the vulnerable plaque to a temperature sufficient to inhibit release of retained fluid from within the vulnerable plaque into the blood stream. The cooling treatment will often be directed against all or a portion of a circumferential surface of a lumen of the blood vessel, and will preferably inhibit release of lipid-rich liquid being releasably retained by the vulnerable plaque.

Cooling of the vessel may be effected by introducing a catheter into a lumen of the blood vessel. A first balloon is positioned within the vessel lumen adjacent the vulnerable plaque. Cryogenic cooling fluid is introduced into the first balloon and exhausted. A second balloon disposed over the first balloon is expanded to radially engage the vessel lumen. Generally, the temperature of an inside surface of the first balloon will be in the range from about  $-55^{\circ}\text{C}$ . to  $-75^{\circ}\text{C}$ . and an outside surface of the first balloon will be in the range from about  $-25^{\circ}\text{C}$ . to  $-45^{\circ}\text{C}$ . The temperature of an outside surface of the second balloon will be in the range from about  $10^{\circ}\text{C}$ . to  $-40^{\circ}\text{C}$ ., preferably from about  $10^{\circ}\text{C}$ . to  $-20^{\circ}\text{C}$ ., more preferably from about  $5^{\circ}\text{C}$ . to  $-10^{\circ}\text{C}$ .

Usually, the temperature at the cell surface of the blood vessel lumen is in the range from about  $10^{\circ}\text{C}$ . to  $-40^{\circ}\text{C}$ ., preferably from about  $10^{\circ}\text{C}$ . to  $-20^{\circ}\text{C}$ ., more preferably from about  $5^{\circ}\text{C}$ . to  $-10^{\circ}\text{C}$ . The tissue is typically maintained at the desired temperature for a time period in the range from about 15 seconds to 120 seconds, preferably from 30 seconds to 60 seconds. Vulnerable plaque stabilization may be enhanced by repeating cooling in cycles, typically with from about 1 to 3 cycles, with the cycles being repeated at a rate of about one cycle every 120 seconds.

Surprisingly, cooling temperatures above  $0^{\circ}\text{C}$ . can effect a transition of the vulnerable plaque's lipid core from a disordered crystalline state fluid to an ordered crystalline state solid or gel. Thus, vulnerable plaque can be stabilized by cooling the lipid-rich liquid sufficiently to change a state of the lipid-rich liquid, typically to a highly ordered hexagonal lattice at transition temperatures generally in the range from about  $10^{\circ}\text{C}$ . to  $-10^{\circ}\text{C}$ . Cooling may stabilize the vulnerable plaque while inhibiting necrosis and/or apoptosis of tissue adjacent the lipid-rich liquid, particularly of the tissues defining a cap of cells between the lipid-rich liquid and the lumen of the blood vessel. Cooling may also inhibit inflammation and deterioration of the vulnerable plaque. The cooling treatment may further inhibit rupture of the cap of cells of the vulnerable plaque.

In other aspects, the present invention of cooling the vulnerable plaque to inhibit release of lipid-rich liquid may be combined with additional treatments. For example, one adjunctive method may comprise treating the cooled vulnerable plaque with a primary treatment. Suitable primary treatments may include balloon angioplasty, atherectomy, rotational atherectomy, laser angioplasty, or the like, where the lumen of the treated blood vessel is enlarged to at least partially alleviate a stenotic condition. The primary treatment may also include procedures for controlling restenosis,

such as stent placement. In the case of arteries, the primary treatment will be effected shortly before, during, or preferably very shortly after the cooling treatment, preferably within 60 seconds of the cooling treatment, more preferably immediately following the cooling of the lipid-rich liquid to a desired temperature. Alternatively, cooling methods may additionally comprise passivating the vulnerable plaque by reducing a size of the lipid-rich liquid, changing a cellular consistency or composition of the lipid-rich liquid, enhancing a structural integrity of the cap (e.g. increasing a thickness of the cap), modifying a cellular composition or structural properties of the cap, and/or the like by altering the chemistry or life cycle of the vulnerable plaque.

In another aspect, the present invention provides a method for treating vulnerable plaque of a blood vessel, the vulnerable plaque releasably retaining fluid. The method includes detecting the vulnerable plaque and cooling the blood vessel adjacent the vulnerable plaque to a temperature sufficient to inhibit release of the retained fluid into the blood vessel.

In another aspect, the present invention provides a method for detecting vulnerable plaque of a blood vessel. The method includes positioning a balloon within the vessel lumen adjacent a plaque. The balloon is inflated so that a plurality of temperature sensors affixed to the balloon are coupled a surface of the vessel lumen. A temperature differential along the lumen surface is sensed with the sensors.

In another aspect, the present invention provides a cryotherapy catheter for detecting and treating vulnerable plaque of a blood vessel having a lumen surface. The catheter generally comprises a catheter body having a proximal end and a distal end with a cooling fluid supply lumen and an exhaust lumen extending therebetween. A first balloon is disposed near the distal end of the catheter body in fluid communication with the supply lumen and exhaust lumen. A second balloon is disposed over the first balloon with a thermal barrier therebetween. A plurality of temperature sensors are affixed to the second balloon so as to provide temperature measurements of the lumen surface.

In another aspect, the present invention provides a catheter for detecting a vulnerable plaque of a blood vessel having a lumen surface. The catheter generally comprises a catheter body having a proximal end and a distal end with a supply lumen and an exhaust lumen extending therebetween. A balloon is disposed on the distal end of the catheter body in fluid communication with the supply lumen and exhaust lumen. A plurality of temperature sensors are supported by the balloon so as to provide temperature measurements of the lumen surface.

In another aspect, the invention also provides a kit for treating vulnerable plaque in a blood vessel. The kit comprises a catheter having a proximal end, a distal end, and a cooling member near its distal end. Instructions are included in the kit for use of the catheter. These instructions comprise the step of cooling the blood vessel adjacent the vulnerable plaque to inhibit release of the retained fluid into the blood vessel. Such a kit may include instructions for any of the methods described herein.

In yet another aspect, the invention provides a kit for detecting vulnerable plaque of a blood vessel. The kit comprises a catheter having a proximal end, a distal end, and a balloon member with a plurality of temperature sensors near its distal end. Instructions are included in the kit for use of the catheter. These instructions comprise the steps of positioning a balloon within the vessel lumen adjacent a plaque, inflating the balloon so that a plurality of temperature sensors affixed to the balloon are coupled to a surface

of the vessel lumen, and sensing a temperature differential along the lumen surface with the sensors. Such a kit may include instructions for any of the methods described herein.

#### BRIEF DESCRIPTION OF THE DRAWINGS

FIGS. 1A and 1B are cross-sectional views of a blood vessel containing a mature vulnerable plaque.

FIG. 2 illustrates a cross-sectional view of a vulnerable plaque rupture and plaque hemorrhage in the blood vessel.

FIG. 3 illustrates a cross-sectional view of a thrombotic occlusion in the blood vessel.

FIG. 4 illustrates an exploded cross-sectional view of FIG. 1A taken along line 4—4.

FIG. 5 illustrates an exemplary cryotherapy catheter for detecting and treating vulnerable plaque.

FIG. 6 is a cross-sectional view of the catheter taken along line 6—6 in FIG. 5.

FIG. 7 is a functional flow diagram illustrating the operation of an automatic fluid shutoff mechanism of the catheter of FIG. 5.

FIGS. 8A and 8B illustrate a handle and removable energy pack for use in the cryotherapy catheter of FIG. 5.

FIG. 9 illustrates a block diagram of a circuit which measures a temperature differential of the lumen surface.

FIG. 10A illustrates an alternative catheter for detecting vulnerable plaque.

FIG. 10B is a cross-sectional view of the catheter taken along line 10B—10B in FIG. 10A.

FIGS. 11A—11C illustrate use of the catheter of FIG. 5 for treatment of vulnerable plaque.

FIG. 12A is a graph illustrating a transition temperature which effects a lipid core transition of the vulnerable plaque.

FIG. 12B illustrates the lipid core transition from a liquid, disordered state to a solid, ordered state.

FIGS. 13A and 13B illustrate additional treatments in conjunction with cooling of the vulnerable plaque.

FIG. 14 illustrates a vulnerable plaque treatment kit including the apparatus of FIG. 5 and instructions for use.

#### DESCRIPTION OF THE SPECIFIC EMBODIMENTS

As used herein, the terms “vulnerable plaque” and “hot plaque” refer to atherosclerotic plaque that is thrombosis-prone. FIGS. 1A and 1B illustrate cross-sectional views of a blood vessel 100 containing a mature vulnerable plaque 102 within a lumen 104 of the vessel. The vulnerable plaque 102 generally comprises a necrotic core 106 of soft, lipid-rich, atheromatous gruel and a fibrous, sclerotic cap 108 of a collagen matrix of smooth muscle cells that covers the core 106. The gruel generally comprises a liquid of esterified cholesterol and low density lipoproteins which is releasably retained by the vulnerable plaque 102. Disruption or fissuring of the cap 108 may cause plaque hemorrhage 110 (release of the highly thrombogenic lipid-rich liquid 106 through the ruptured plaque), as seen in FIG. 2. As a result of plaque hemorrhage 110, the highly thrombogenic lipid-rich liquid 106 is exposed to flowing blood of the vessel lumen 104. As illustrated in FIG. 3, release of the thrombogenic liquid may cause a thrombotic occlusion 112 (blood clot) of the entire vessel lumen, which in turn may be lead to life-threatening conditions, such as a stroke or sudden cardiac death.

Three determinants of vulnerability are illustrated in FIG. 4, which is an exploded cross-sectional view of FIG. 1A

taken along line 4—4. Susceptibility of a vulnerable plaque to rupture may be primarily determined from the size 114 and consistency of the atheromatous core (e.g. a larger core increases chances for rupture), the thickness 116 and structural integrity of the sclerotic cap (e.g. a thinner cap increases chances for rupture), and cap inflammation (e.g. macrophage foam cell 118 infiltration weakens the cap cells 120 and increases chances for rupture). Additionally, vulnerable plaque disruption may be triggered by numerous extrinsic stresses imposed on the plaque. For example, fluctuations in intraluminal blood pressure, pulse pressure, heart contraction, vasospasm, and the like may precipitate disruption of a vulnerable plaque. Alternatively, mechanical stresses caused by primary treatments like PTA or stenting may trigger rupture as well.

Referring now to FIGS. 5 and 6, an exemplary cryotherapy catheter 10 (which is more fully described in application Ser. No. 09/619,583 filed Jul. 19, 2000, the full disclosure of which is incorporated herein by reference) for detecting and treating vulnerable plaque 102 of a blood vessel 100 having a lumen surface 105 (see FIG. 1A) will be described. The catheter 10 comprises a catheter body 12 having a proximal end 14 and a distal end 16 with a cooling fluid supply lumen 18 and an exhaust lumen 20 extending therebetween. A first balloon 22 is disposed near the distal end of the catheter body 12 in fluid communication with the supply and exhaust lumens. A second balloon 24 is disposed over the first balloon 22 with a thermal barrier 26 therebetween.

The balloons 22, 24 may be an integral extension of the catheter body 12, but such a structure is not required by the present invention. The balloons 22, 24 could be formed from the same or a different material as the catheter body 12 and, in the latter case, attached to the distal end 16 of the catheter body 12 by suitable adhesives, heat welding, or the like. The catheter body 12 may be formed from conventional materials, such as polyethylenes, polyimides, and copolymers and derivatives thereof. The balloons 22, 24 may also be formed from conventional materials used for angioplasty, preferably being inelastic, such as polyethylene terephthalate (PET), polyethylene, or other medical grade material suitable for constructing a strong non-distensible balloon. Additionally, balloons 22 and 24 could be formed from different material to provide improved protection. For example, the first balloon 22 could be formed from PET to provide strength while the second balloon 24 could be formed from polyethylene to provide durability. The balloons 22, 24 have a length of at least 1 cm each, more preferably in the range from 2 cm to 5 cm each. The balloons 22, 24 will have diameters in the range from 2 mm to 5 mm each in a coronary artery and 2 mm to 10 mm each in a peripheral artery.

The thermal barrier 26 may comprise a gap maintained between the balloons 22, 24 by a filament. The filament typically comprises a helically wound, braided, woven, or knotted monofilament. The monofilament may be formed from PET or polyethylene naphthlate (PEN), and affixed to the first balloon 22 by adhesion bonding, heat welding, fasteners, or the like. The thermal barrier 26 may also comprise a gap maintained between the balloons 22, 24 by a plurality of bumps on an outer surface of the first balloon 22 and/or an inner surface of the second balloon 24. The plurality of bumps may be formed in a variety of ways. For example, the bumps may be intrinsic to the balloon (created during balloon blowing), or the bumps could be created by deforming the material of the balloon wall, by affixing mechanical “dots” to the balloon using adhesion bonding,

heat welding, fasteners, or the like. Alternatively, the thermal barrier 26 may comprise a gap maintained between the balloons 22, 24 by a sleeve. The sleeve may be perforated and formed from PET or rubbers such as silicone and polyurathane.

Hubs 34 and 36 are secured to the proximal end 14 of the catheter body 12. Hub 34 provides a port 38 for connecting a cryogenic fluid source to the fluid supply lumen 18 which is in turn in fluid communication with the inner surface of the first balloon 22. Hub 34 further provides a port 40 for exhausting the cryogenic fluid which travels from balloon 22 in a proximal direction through the exhaust lumen 20. Hub 36 provides a port 42 for a guidewire which extends through a guidewire lumen 44 in the catheter body 12. Typically, the guidewire lumen 44 will extend through the exhaust lumen 20, as shown in FIG. 6. The guidewire lumen 44 may also extend axially outside the exhaust lumen 20 to minimize the occurrence of cryogenic fluid entering the blood stream via the guidewire lumen 44. Optionally, the guidewire lumen 44 may extend outside the inner surface of the first balloon 22 or the guidewire lumen 44 may allow for a guidewire to extend outside both balloons 22, 24. Additionally, a reinforcing coil 46 may extend along the catheter body 12 proximal the first balloon 22. The reinforcing coil 46 may comprise a simple spring having a length typically in the range from 6 cm to 10 cm to prevent the catheter 10 from kinking up inside the blood vessel.

The cryotherapy catheter 10 in FIG. 5 additionally illustrates a safety mechanism that monitors the containment of the first and second balloons 22, 24. The first balloon 22 defines a volume in fluid communication with the supply and exhaust lumens. A fluid shutoff is coupled to a cryogenic fluid supply with the supply lumen 18. The second balloon 24 is disposed over the first balloon 22 with a vacuum space 52 therebetween. The vacuum space 52 is coupled to the fluid shutoff so as to inhibit flow of cryogenic fluid into the first balloon 22 in response to a change in the vacuum space 52.

FIG. 7 illustrates a functional flow diagram of the automatic fluid shutoff mechanism 54. The fluid shutoff 54 typically comprises a vacuum switch 56 connected to a shutoff valve 58 by a circuit, the circuit being powered by a battery 60. The switch 56 may remain closed only when a predetermined level of vacuum space 52 is detected in the second balloon 24. The closed switch 56 allows the shutoff valve 58, in fluid communication with the cryogenic fluid supply 62, to be open. Alternatively, the circuit may be arranged so that the switch 56 is open only when the predetermined vacuum space 52 is present, with the shutoff valve 58 being open when the switch is open. The vacuum space 52 is reduced when either the first balloon 22 is punctured, allowing cryogenic fluid to enter the vacuum space 52, or the second balloon 24 is punctured, allowing blood to enter the vacuum space 52. In addition to monitoring the containment of both balloons 22, 24, in the event of a failure, the vacuum switch 56 will be triggered to prevent the delivery of additional cryogenic fluid from the fluid supply 62 into the supply lumen 18. The second balloon 24 also acts to contain any cryogenic fluid that may have escaped the first balloon 22.

The vacuum space 52 may be provided by a simple fixed vacuum chamber 64 coupled to the vacuum space 52 by a vacuum lumen 66 of the body 12 via a vacuum port 68 (See FIG. 5). In the exemplary embodiment, a positive displacement pump (ideally being similar to a syringe) is disposed within handle 74 and may be actuated by actuator 75, as seen in FIG. 8A. The vacuum space 52 should comprise a small

volume of vacuum in the range from 1 mL to 100 mL, preferably 10 mL or less, as a smaller vacuum space 52 facilitates detection of a change in the amount of vacuum when a small amount of fluid leakage occurs. The cryogenic fluid supply 62 and battery 60 for powering the circuit may be packaged together in an energy pack 70, as seen in FIG. 8B. The energy pack 70 is detachable from a proximal handle 74 of the catheter body and disposable. A plurality of separate replaceable energy packs 70 allow for multiple cryogenic cooling cycles. Additionally, an audio alert or buzzer 76 may be located on the handle 74, with the buzzer providing an audio warning unless the handle is maintained sufficiently upright to allow flow from the fluid supply 62. The cryotherapy catheter may additionally comprise a hypsometer 72 coupled to the volume by a thermistor, thermocouple, or the like located in the first balloon 22 or handle to determine the pressure and/or temperature of fluid in the first balloon 22. The hypsometer allows for accurate real time measurements of variables (pressure, temperature) that effect the efficacy and safety of cryotherapy treatments.

The dual balloon cryotherapy catheter 10 in FIG. 5 also illustrates a temperature sensing mechanism that provides for thermographic detection of vulnerable plaque. A plurality of temperature sensors 78 are affixed to the second balloon 24 so as to provide direct temperature measurements of the lumen surface 105 (see FIG. 1A). The temperature sensors 78 may comprise a plurality of up to 20 thermocouples or thermistors and may be capable of detecting temperature differences greater than 0.1° C. The temperature sensors 78 may be secured to the second balloon 24 at a series of axial and circumferential locations. The plurality of temperature sensors 78 may be affixed by adhesion bonding, heat welding, fasteners, or the like to an outer surface of the second balloon 24, as shown in FIG. 5, or may be alternatively affixed to an inner surface of the second balloon 24. Temperature sensor wires 80 may be secured along the length of the catheter shaft 12 within a thin sleeve 82 formed from PET or rubbers such as silicone and polyurathane, or in the latter case the wires 80 may be threaded through the vacuum lumen 66. A connector 84 at the proximal end 14 of the catheter 10 may also be provided to connect the temperature sensor wires 80 to a temperature readout device for temperature mapping along the lumen surface. Additionally, a circuit 77 may be attached to the connector 84 for measuring a temperature differential  $\Delta T$  along the lumen surface from temperature measurement T1 and T2 sensed by the temperature sensors 78, as illustrated in the block diagram of FIG. 9. An indicator which is triggered above a threshold temperature differential may also be located on the connector for alerting purposes.

Detection of vulnerable plaque may be carried out by introducing the cryotherapy catheter 10 into a lumen 104 of the blood vessel 100 over a guidewire. The first balloon 22 is positioned within the blood vessel lumen 104 adjacent a plaque. The first balloon 22 is inflated so that the plurality of temperature sensors 78 affixed to the second balloon 24 (which expands upon inflation) thermally couple a surface of the vessel lumen. A temperature differential along the lumen surface 105 is sensed with the sensors. Inflation of balloon 22 may be effected by a gas, such as carbon dioxide, nitrous oxide, or the like, at a pressure in the range from about 5 psi to 50 psi. The balloon 22 will typically be inflated for a time period in the range from 10 to 120 seconds. The balloon catheter may sense for a temperature differential in a static position or as it moving along the lumen surface. Advantageously, temperature sensors 78 thermally engage the lumen surface to allow for direct temperature measure-

ments to be made at specific locations along the lumen surface. This increased temperature sensitivity may in turn lead to improved temperature mapping and accurate vulnerable plaque detections. Cryotherapy catheter **10** may then be used for treating the detected vulnerable plaque as described in more detail below with reference to FIGS. **11A–11C**.

An alternative catheter **10'** for detecting a vulnerable plaque of a blood vessel having a lumen surface is illustrated in FIGS. **10A** and **10B**. Detection catheter **10'** comprises a catheter body **12** having a proximal end **14** and a distal end **16** with a supply lumen **88** and an exhaust lumen **88** extending therebetween. A balloon **86** is disposed on the distal end of the catheter body **12**. Balloon **86** has an inner surface in fluid communication with the supply lumen and exhaust lumen. A plurality of temperature sensors **78** are affixed to an outer surface of the balloon **86** so as to provide direct temperature measurements of the lumen surface **105** (see FIG. **1A**).

Detection of vulnerable plaque may be carried out by introducing the detection catheter **10'** into a lumen **104** of the blood vessel **100** over a guidewire. The balloon **86** is positioned within the vessel lumen adjacent a plaque. The balloon **86** is inflated so that a plurality of temperature sensors **78** affixed to the balloon thermally couple a surface of the vessel lumen. A temperature differential along the lumen surface is sensed with the sensors. Balloon **86** is generally inflatable with standard inflation media, such as contrast, saline, or the like. An inflation media supply and/or exhaust port **90** is connected to the supply and/or exhaust lumen **88** which is in turn in fluid communication with the inner surface of balloon **86**. Balloon **86** will typically be inflated for a time period in the range from 10 to 120 seconds. The balloon catheter may sense for a temperature differential in a static position or as it moving along the lumen surface.

Referring now to FIGS. **11A** through **11C**, use of cryotherapy catheter **10** of FIG. **5** for treatment of vulnerable plaque **102** will be described. As illustrated in FIG. **11A** and **11B**, catheter **10** will be introduced into a lumen **104** of the blood vessel **100** over a guidewire GW. The first balloon **22** is positioned within the blood vessel lumen **104** adjacent the vulnerable plaque **102**. Cryogenic cooling fluid is introduced into the first balloon **22** (in which it often vaporizes) and exhausted. The second balloon **24** expands to radially engage the vessel wall, as illustrated by FIG. **11C**. The vaporized fluid serves both to inflate balloon **22** (and expand balloon **24**) and to cool the exterior surface of the balloons **22, 24**. The blood vessel **100** adjacent the vulnerable plaque **102** is cooled to a temperature sufficient to inhibit release of retained fluid **106** from within the vulnerable plaque **102** into the blood vessel **100**. The cooling treatment will be directed at all or a portion of a circumferential surface the vessel lumen. Preferably cooling will inhibit release of lipid-rich liquid being releasably retained by the vulnerable plaque by stabilizing the lipid-rich liquid **106** to a lipid-rich solid or gel **106'** (which is described in more detail in FIGS. **12A–12B** below). Heat transfer will also be inhibited between the first and second balloons **22, 24** by the thermal barrier **26** so as to limit cooling of the vulnerable plaque to a desired temperature profile. Additionally, containment of the first and second balloons **22, 24** will be monitored during cooling by the fluid shutoff mechanism (see FIG. **7**).

Suitable cryogenic fluids will preferably be non-toxic and may include liquid nitrous oxide, liquid carbon dioxide, cooled saline and the like. The cryogenic fluid will flow through the supply lumen said at an elevated pressure and will vaporize at a lower pressure within the first balloon **22**.

For nitrous oxide, a delivery pressure within the supply lumen **18** will typically be in the range from 600 psi to 1000 psi at a temperature below the associated boiling point. After vaporization, the nitrous oxide gas within the first balloon **22** near its center will have a pressure typically in the range from 15 psi to 100 psi. Preferably, the nitrous oxide gas will have a pressure in the range from 50 psi to 100 psi in a peripheral artery and a range from about 15 psi to 45 psi in a coronary artery.

Generally, the temperature of an inside surface of the first balloon will be in the range from about  $-55^{\circ}\text{C}$ . to  $-75^{\circ}\text{C}$ . and an outside surface of the first balloon will be in the range from about  $-25^{\circ}\text{C}$ . to  $-45^{\circ}\text{C}$ . The temperature of an outside surface of the second balloon will be in the range from about  $10^{\circ}\text{C}$ . to  $-40^{\circ}\text{C}$ ., preferably from about  $10^{\circ}\text{C}$ . to  $-20^{\circ}\text{C}$ ., more preferably from about  $5^{\circ}\text{C}$ . to  $-10^{\circ}\text{C}$ . This will provide a desired treatment temperature in a range from about  $10^{\circ}\text{C}$ . to  $-40^{\circ}\text{C}$ ., preferably from about  $10^{\circ}\text{C}$ . to  $-20^{\circ}\text{C}$ ., more preferably from about  $5^{\circ}\text{C}$ . to  $-10^{\circ}\text{C}$ . The tissue is typically maintained at the desired temperature for a time period in the range from about 15 to 120 seconds, preferably being from 30 to 60 seconds. Vulnerable plaque stabilization may be enhanced by repeating cooling in cycles, typically with from about 1 to 3 cycles, with the cycles being repeated at a rate of about one cycle every 120 seconds.

In some instances, cooling of the vessel may be limited to inhibiting necrosis and/or apoptosis of tissue adjacent the lipid-rich liquid, particularly of the tissues defining a cap of cells **108** between the lipid-rich liquid **106** and the lumen of the blood vessel **104** (see FIG. **1A**). Apoptosis or cell necrosis may be undesirable if it weakens the cap of cells as cap weakening may likely incite rupture of the vulnerable plaque and release of the lipid-rich liquid. Thus, the present invention may inhibit release of the retained fluid into the blood vessel without affecting the viability of the cap cells **108** and other cells which line the body lumen.

In other applications, cooling of the vessel at cooler temperatures may be desirable to provide for apoptosis and/or programmed cell death stimulation of inflammatory cells (e.g. macrophages **118**, see FIG. **4**) in the vulnerable plaque **102**. Apoptosis may be desirable as the presence of such inflammatory cells may trigger cap weakening or erosion which in turn may lead to vulnerable plaque release of the lipid-rich liquid. Cooling at temperatures in the range from about  $0^{\circ}\text{C}$ . to  $-15^{\circ}\text{C}$ . may inhibit inflammation and deterioration of the vulnerable plaque, particularly of the tissues defining the cap of cells **108**. Alternatively, it may be beneficial to provide for necrosis in the cap cells **108** at cooling temperatures below about  $-20^{\circ}\text{C}$ . Cap necrosis may stimulate cellular proliferation and thickening of the cap which in turn may inhibit cap rupture.

Referring now to FIGS. **12A** and **12B**, transition of the vulnerable plaque's lipid-rich liquid core **106** will be described. FIG. **12A** illustrates the transition temperature which effects a lipid core transition. The main transition point **122** occurs at some point between the transition temperature range of  $10^{\circ}\text{C}$ . to  $-10^{\circ}\text{C}$ . At this transition point **122**, the lipid core may undergo a phase change from a disordered crystalline state fluid **106** to an ordered crystalline state solid or gel **106'**, as shown in FIG. **12B**. Thus, vulnerable plaque can be stabilized by cooling the lipid-rich liquid core **106** sufficiently to change its state, typically from a disordered lipid to a highly ordered hexagonal lattice. Advantageously, a transition temperature above  $-5^{\circ}\text{C}$ . also inhibits necrosis and/or apoptosis of tissue adjacent the lipid-rich liquid **106**, particularly of the cap **108**.

With reference now to FIGS. 13A and 13B, additional treatments in conjunction with cooling of the vulnerable plaque will be illustrated. FIG. 13A illustrates a cross section of a blood vessel 100 that has been cooled so that the vulnerable plaque has been stabilized to lipid-rich solid/gel 106'. A stent 124 has been placed within the vessel lumen while the plaque is stabilized to provide a long-term restraint of lipid-rich fluid 106, and possibly to provide a structural scaffolding for healthy endothelial cells via tissue ingrowth. The stent may also alleviate plaque-induced stenosis and to improve the patency of the lumen. Other suitable primary treatments of the stabilized plaque may include balloon angioplasty, atherectomy, rotational atherectomy, laser angioplasty, or the like, where the lumen of the treated blood vessel is enlarged to at least partially alleviate a stenotic condition. In the case of arteries, the primary treatment will be effected shortly before, during, or preferably very shortly after the cooling treatment, preferably within 60 seconds of the cooling treatment, more preferably immediately following the cooling of the lipid-rich liquid to a desired temperature. In some instances, cooling may effect passivation of the vulnerable plaque, possibly reducing a size of the lipid-rich liquid 106", as illustrated in FIG. 13B, or modifying a cellular consistency or composition of the lipid-rich liquid, and/or the like by altering the chemistry or life cycle of the vulnerable plaque. Passivation may also include enhancing a structural integrity of cap 108 (e.g. increasing the thickness, strength, elasticity, or hardness of the cap), modifying a cellular composition or property of the cap, and/or the like via scar formation or alteration of the chemistry of the vulnerable plaque.

A kit 126 including a catheter 10 and instructions for use 128 is illustrated in FIG. 14. Catheter 10 may comprise the dual balloon catheter of FIG. 5, as illustrated in FIG. 14, or a catheter having a proximal end, a distal end, and a cooling member near its distal end. Instructions for use 128 may describe any of the associated method steps set forth above for detection and/or treatment of vulnerable plaque. Instructions for use 128 will often be printed, optionally appearing at least in part on a sterile package 130 for balloon catheter 10. In alternative embodiments, instructions for use 128 may comprise a machine readable code, digital or analog data graphically illustrating or demonstrating the use of balloon catheter 10 to detect and/or treat vulnerable plaque. Still further alternatives are possible, including printing of the instructions for use on packaging 132 of kit 126, and the like.

While the above is a complete description of the preferred embodiments of the invention, various alternatives, modifications, and equivalents will be obvious to those of skill in the art. Hence, the above description should not be taken as limiting the scope of the invention which is defined by the appended claims.

What is claimed is:

1. A method for treating vulnerable plaque of a blood vessel, the vulnerable plaque releasably retaining fluid, said method comprising:
  - 5 cooling the blood vessel adjacent the vulnerable plaque to a temperature sufficient to inhibit release of the retained fluid into the blood vessel, wherein the cooling step comprises:
    - introducing a catheter into a lumen of the blood vessel;
    - 10 positioning a first balloon within the vessel lumen adjacent the vulnerable plaque;
    - introducing a cryogenic cooling fluid into the first balloon;
    - 15 exhausting the cooling fluid; and
    - expanding a second balloon disposed over the first balloon to radially engage the vessel lumen.
  2. A method as in claim 1, wherein a temperature of an outer surface of the first balloon is in the range from about -25° C. to -45° C. and a temperature of an outer surface the second balloon is in the range from about 10° C. to -40° C.
  3. A method as in claim 1, wherein the blood vessel is an artery.
  4. A method as in claim 1, wherein the fluid of the vulnerable plaque comprises a lipid-rich liquid.
  5. A method as in claim 4, wherein the vulnerable plaque comprises a cap of cells between the lipid-rich liquid and a lumen of the blood vessel.
  6. A method as in claim 5, further comprising inhibiting apoptosis of tissue adjacent the lipid-rich liquid.
  7. A method as in claim 5, wherein the cooling step inhibits rupture of the cap of cells.
  8. A method as in claim 1, wherein the cooling step comprises lowering the temperature of the blood vessel surface from about 10° C. to -40° C. for a time period in the range from about 15 to 120 seconds.
  9. A method as in claim 4, further comprising stabilizing the vulnerable plaque by cooling the lipid-rich liquid to a highly ordered hexagonal lattice.
  10. A method as in claim 9, wherein the lipid-rich liquid is hardened to at least a gel-state.
  11. A method as in claim 1, wherein the cooling inhibits inflammation of the vulnerable plaque.
  12. A method as in claim 1, wherein the cooling inhibits deterioration of the vulnerable plaque.
  13. A method as in claim 1, further comprising treating the vulnerable plaque with a primary treatment.
  14. A method as in claim 4, further comprising passivating the vulnerable plaque by reducing a size or modifying a consistency or composition of the lipid-rich liquid.
  15. A method as in claim 14, wherein passivation is carried out by altering the chemistry or life cycle of the vulnerable plaque.
  16. A method as in claim 5, further comprising passivating the vulnerable plaque by increasing a thickness of the cap of cells.

\* \* \* \* \*

专利名称(译)	用于检测和治疗易损斑块的冷冻方法		
公开(公告)号	<a href="#">US6602246</a>	公开(公告)日	2003-08-05
申请号	US09/641462	申请日	2000-08-18
[标]申请(专利权)人(译)	CRYOVASCULAR SYST		
申请(专利权)人(译)	CRYOVASCULAR系统公司.		
当前申请(专利权)人(译)	CRYOVASCULAR系统公司.		
[标]发明人	JOYE JAMES TATSUTANI KRISTINE		
发明人	JOYE, JAMES TATSUTANI, KRISTINE		
IPC分类号	A61B18/00 A61B18/02 A61B17/22 A61B17/00 A61B5/00 A61B18/18		
CPC分类号	A61B5/01 A61B5/6853 A61B18/02 A61B2017/00101 A61B2017/22001 A61B2017/22002 A61B2017/22051 A61B2018/0022 A61B2018/0212 A61B2018/0262		
外部链接	<a href="#">Espacenet</a> <a href="#">USPTO</a>		

摘要(译)

本发明提供了用于检测和/或治疗具有管腔表面的血管的易损斑块的方法，装置和试剂盒。检测方法包括利用热耦合腔表面的温度传感器来感测沿着腔表面的温差。治疗方法包括对易损斑块进行受控和安全的低温冷却，以抑制易损斑块内保留液体的释放，从而抑制急性冠状动脉综合征并帮助维持体腔通畅。治疗方法可包括额外的治疗，例如初级治疗或钝化。

