



US009149193B2

(12) **United States Patent**  
**Wolinsky et al.**

(10) **Patent No.:** **US 9,149,193 B2**  
(45) **Date of Patent:** **Oct. 6, 2015**

(54) **DEVICES FOR FIXING A SENSOR IN A LUMEN**

(75) Inventors: **Lone Wolinsky**, Ramat Gan (IL); **Alon Ben-Yoseph**, Amek Yisrael (IL); **Abraham Penner**, Tel Aviv (IL)

(73) Assignee: **Remon Medical Technologies LTD**, Caesarea (IL)

(\* ) Notice: Subject to any disclaimer, the term of this patent is extended or adjusted under 35 U.S.C. 154(b) by 275 days.

(21) Appl. No.: **12/496,904**

(22) Filed: **Jul. 2, 2009**

(65) **Prior Publication Data**  
US 2009/0270742 A1 Oct. 29, 2009

**Related U.S. Application Data**

(63) Continuation of application No. 11/034,502, filed on Jan. 12, 2005, now Pat. No. 7,572,228.

(60) Provisional application No. 60/536,580, filed on Jan. 13, 2004.

(51) **Int. Cl.**  
*A61B 5/02* (2006.01)  
*A61B 5/0215* (2006.01)  
*A61B 5/00* (2006.01)  
*A61F 2/86* (2013.01)  
*A61B 5/145* (2006.01)  
*A61F 2/82* (2013.01)

(52) **U.S. Cl.**  
CPC ..... *A61B 5/0215* (2013.01); *A61B 5/0031* (2013.01); *A61B 5/6882* (2013.01); *A61B 5/6886* (2013.01); *A61F 2/86* (2013.01); *A61B 5/145* (2013.01); *A61F 2/82* (2013.01); *A61F 2230/0091* (2013.01); *A61F 2250/0002* (2013.01)

(58) **Field of Classification Search**  
CPC ..... A61B 5/021; A61B 5/0215  
USPC ..... 600/481, 485-488, 547  
See application file for complete search history.

(56) **References Cited**

U.S. PATENT DOCUMENTS

3,874,388 A 4/1975 King et al.  
4,391,124 A 7/1983 Drost et al.  
4,407,296 A 10/1983 Anderson  
4,485,813 A 12/1984 Anderson et al.  
4,492,107 A 1/1985 Sandhu

(Continued)

FOREIGN PATENT DOCUMENTS

EP 0897690 2/1999  
EP 0928598 8/2000

(Continued)

OTHER PUBLICATIONS

Holmes et al. "Sirolimus Eluting Stents vs. Vascular Brachytherapy for InStent Restenosis Within BareMetal Stents" JAMA295 (11): 1264-1273 Mar. 15, 2006.

(Continued)

*Primary Examiner* — Michael D'Angelo  
(74) *Attorney, Agent, or Firm* — Faegre Baker Daniels LLP

(57) **ABSTRACT**

Apparatus for positioning at least one sensor in a body lumen, the apparatus including a fixation element, a sensor, and a connecting element that connects the sensor to the fixation element, the connecting element extending at least partially into the lumen so that the sensor is located radially inward from a wall of the lumen.

**19 Claims, 4 Drawing Sheets**

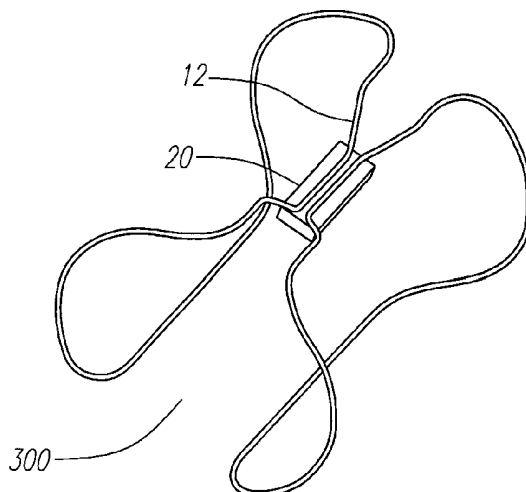

(56)

## References Cited

## U.S. PATENT DOCUMENTS

4,672,976 A	6/1987	Kroll	6,628,989 B1	9/2003	Penner et al.
4,836,204 A	6/1989	Landymore et al.	6,645,143 B2	11/2003	Van Tassel et al.
4,846,191 A	7/1989	Brockway et al.	6,660,021 B1	12/2003	Palmer et al.
4,886,065 A	12/1989	Collings, Jr.	6,685,638 B1	2/2004	Taylor et al.
4,900,303 A	2/1990	Lemelson	6,699,186 B1	3/2004	Wolinsky et al.
4,917,089 A	4/1990	Sideris	6,702,847 B2	3/2004	DiCarlo
4,966,148 A	10/1990	Millar	6,730,108 B2	5/2004	Van Tassel et al.
5,040,538 A	8/1991	Mortazavi	6,738,671 B2	5/2004	Christophersom et al.
5,218,965 A	6/1993	Ring	6,743,173 B2	6/2004	Penner et al.
5,284,138 A	2/1994	Kujawski	6,746,404 B2	6/2004	Schwartz
5,303,207 A	4/1994	Brady et al.	6,747,916 B1	6/2004	Fleury et al.
5,334,217 A	8/1994	Das	6,755,855 B2	6/2004	Yurek et al.
5,411,551 A	5/1995	Winston et al.	6,764,446 B2	7/2004	Wolinsky et al.
5,415,630 A	5/1995	Gory et al.	6,783,499 B2	8/2004	Schwartz
5,451,235 A	9/1995	Lock et al.	6,800,060 B2	10/2004	Marshall
5,509,900 A *	4/1996	Kirkman ..... 604/104	6,840,956 B1	1/2005	Wolinsky et al.
5,604,531 A	2/1997	Iddan et al.	6,855,115 B2	2/2005	Fonseca et al.
5,634,936 A	6/1997	Linden et al.	6,868,288 B2	3/2005	Thompson
5,656,036 A	8/1997	Palmaz	6,890,303 B2	5/2005	Fitz
5,662,711 A	9/1997	Douglas	6,899,729 B1	5/2005	Cox et al.
5,704,352 A	1/1998	Tremblay et al.	6,904,308 B2	6/2005	Frisch et al.
5,725,552 A	3/1998	Kotula et al.	6,920,347 B2	7/2005	Simon et al.
5,733,249 A	3/1998	Katzin et al.	6,926,670 B2	8/2005	Rich
5,733,294 A *	3/1998	Forber et al. .... 606/151	6,934,573 B1	8/2005	Glukhovskiy et al.
5,733,313 A	3/1998	Barreras, Sr. et al.	6,950,690 B1	9/2005	Meron et al.
5,772,669 A	6/1998	Vrba	6,958,034 B2	10/2005	Iddan
5,775,331 A	7/1998	Raymond et al.	6,970,742 B2	11/2005	Mann et al.
5,800,497 A	9/1998	Bakels et al.	6,972,017 B2	12/2005	Smith et al.
5,824,053 A *	10/1998	Khosravi et al. .... 623/1.15	6,984,205 B2	1/2006	Gazdzinski
5,833,603 A	11/1998	Kovacs et al.	7,001,329 B2	2/2006	Kobayashi et al.
5,855,563 A	1/1999	Kaplan et al.	7,006,858 B2	2/2006	Silver et al.
5,860,923 A	1/1999	Lenker et al.	7,009,634 B2	3/2006	Iddan et al.
5,891,154 A	4/1999	Loeffler	7,011,671 B2	3/2006	Welch
5,967,980 A	10/1999	Ferre et al.	7,024,248 B2	4/2006	Penner et al.
5,967,986 A	10/1999	Cimochowski et al.	7,033,322 B2	4/2006	Silver
5,967,989 A	10/1999	Cimochowski et al.	7,035,684 B2	4/2006	Lee
5,995,876 A	11/1999	Kruse et al.	7,039,453 B2	5/2006	Mullick et al.
6,002,969 A	12/1999	Machek et al.	7,060,038 B2	6/2006	Letort et al.
6,015,386 A	1/2000	Kensey et al.	7,064,472 B2	6/2006	Peline et al.
6,015,387 A	1/2000	Schwartz et al.	7,065,409 B2	6/2006	Mazar
6,030,413 A	2/2000	Lazarus	7,065,709 B2	6/2006	Ellis et al.
6,033,366 A	3/2000	Brockway et al.	7,083,822 B2	8/2006	Brightbill
6,053,873 A *	4/2000	Govari et al. .... 600/505	7,116,352 B2	10/2006	Yaron
6,076,016 A	6/2000	Feierbach	7,118,529 B2	10/2006	Glukhovskiy et al.
6,077,227 A	6/2000	Miesel et al.	7,118,531 B2	10/2006	Krill
6,097,984 A	8/2000	Douglas	7,131,986 B2	11/2006	Sirhan et al.
6,106,464 A	8/2000	Bass et al.	7,160,258 B2	1/2007	Imran et al.
6,140,740 A	10/2000	Porat et al.	7,181,261 B2	2/2007	Silver et al.
6,159,156 A	12/2000	Van Bockel	7,198,603 B2	4/2007	Penner et al.
6,179,858 B1	1/2001	Squire et al.	7,211,045 B2	5/2007	Dala-Krishna et al.
6,193,745 B1	2/2001	Fogarty et al.	7,273,457 B2	9/2007	Penner
6,214,025 B1	4/2001	Thistle et al.	7,283,874 B2	10/2007	Penner
6,231,516 B1	5/2001	Keilman et al.	7,308,319 B2	12/2007	Lovett et al.
6,236,889 B1	5/2001	Soykan et al.	7,338,512 B2	3/2008	McGuckin, Jr. et al.
6,239,724 B1	5/2001	Doron et al.	7,347,868 B2	3/2008	Burnett et al.
6,240,312 B1	5/2001	Alfano et al.	7,392,094 B2	6/2008	Zhang et al.
6,246,898 B1	6/2001	Vesely et al.	7,437,193 B2	10/2008	Parramon et al.
6,277,078 B1	8/2001	Porat et al.	7,452,334 B2	11/2008	Gianchandani et al.
6,278,790 B1	8/2001	Davis et al.	7,477,946 B2	1/2009	Tockman et al.
6,309,350 B1	10/2001	Van Tassel	7,555,351 B2	6/2009	Zhang et al.
6,328,669 B1	12/2001	Imanishi et al.	7,780,694 B2	8/2010	Palmer et al.
6,328,699 B1	12/2001	Eigler et al.	7,850,708 B2	12/2010	Pal
6,331,163 B1	12/2001	Kaplan	7,890,188 B2	2/2011	Zhang et al.
6,379,308 B1	4/2002	Brockway et al.	9,026,229 B2	5/2015	Stalker et al.
6,409,674 B1	6/2002	Brockway et al.	2002/0077555 A1 *	6/2002	Schwartz ..... 600/486
6,416,474 B1	7/2002	Penner et al.	2002/0123672 A1	9/2002	Christophersom et al.
6,432,050 B1	8/2002	Porat et al.	2002/0151816 A1 *	10/2002	Rich et al. .... 600/547
6,442,413 B1	8/2002	Silver	2002/0165601 A1	11/2002	Clerc
6,447,522 B2	9/2002	Gambale et al.	2002/0183628 A1	12/2002	Reich et al.
6,475,170 B1	11/2002	Doron et al.	2002/0188207 A1	12/2002	Richter
6,486,588 B2	11/2002	Doron et al.	2003/0114897 A1	6/2003	Von Arx et al.
6,527,780 B1	3/2003	Wallace et al.	2003/0139796 A1	7/2003	Sequin et al.
6,543,272 B1	4/2003	Vitek	2003/0195606 A1	10/2003	Davidson et al.
6,585,763 B1	7/2003	Keilman et al.	2003/0200031 A1	10/2003	de Kok
6,592,553 B2	7/2003	Zhang et al.	2004/0006377 A1	1/2004	Behm
			2004/0054403 A1	3/2004	Israel
			2004/0116992 A1 *	6/2004	Wardle et al. .... 607/116
			2004/0147969 A1	7/2004	Mann et al.
			2004/0176672 A1	9/2004	Silver et al.

(56)

## References Cited

## FOREIGN PATENT DOCUMENTS

## U.S. PATENT DOCUMENTS

2004/0204744 A1 10/2004 Penner et al.  
 2004/0215228 A1 10/2004 Simpson et al.  
 2005/0080472 A1 4/2005 Atkinson et al.  
 2005/0096702 A1 5/2005 Denker et al.  
 2005/0115561 A1 6/2005 Stahmann et al.  
 2005/0124875 A1 6/2005 Heil, Jr. et al.  
 2005/0136385 A1 6/2005 Mann et al.  
 2005/0149108 A1 7/2005 Cox  
 2005/0149128 A1 7/2005 Heil, Jr. et al.  
 2005/0149155 A1 7/2005 Scheiner et al.  
 2005/0149156 A1 7/2005 Libbus et al.  
 2005/0154321 A1 7/2005 Wolinsky et al.  
 2005/0165456 A1 7/2005 Mann et al.  
 2005/0182387 A1 8/2005 Webler  
 2005/0209678 A1 9/2005 Henkes et al.  
 2005/0245840 A1 11/2005 Christopherson et al.  
 2006/0009818 A1 1/2006 Von Arx et al.  
 2006/0047205 A1 3/2006 Ludomirsky et al.  
 2006/0064133 A1 3/2006 Von Arx et al.  
 2006/0064134 A1 3/2006 Mazar et al.  
 2006/0064142 A1 3/2006 Chavan et al.  
 2006/0064143 A1 3/2006 Von Arx et al.  
 2006/0079740 A1 4/2006 Silver et al.  
 2006/0089627 A1 4/2006 Burnett et al.  
 2006/0089694 A1 4/2006 Zhang et al.  
 2006/0122522 A1 6/2006 Chavan et al.  
 2006/0136004 A1 6/2006 Cowan et al.  
 2006/0142819 A1 6/2006 Penner et al.  
 2006/0149329 A1 7/2006 Penner  
 2006/0149330 A1 7/2006 Mann et al.  
 2006/0178586 A1 8/2006 Dobak, III  
 2006/0206153 A1 9/2006 Libbus et al.  
 2006/0241735 A1 10/2006 Tockman et al.  
 2006/0259085 A1 11/2006 Zhang et al.  
 2006/0287700 A1 12/2006 White et al.  
 2006/0293741 A1 12/2006 Johnson et al.  
 2007/0049833 A1 3/2007 Tearney et al.  
 2007/0060959 A1 3/2007 Salo et al.  
 2007/0129637 A1 6/2007 Wolinsky et al.  
 2007/0156126 A1 7/2007 Flaherty  
 2007/0156205 A1 7/2007 Larson et al.  
 2007/0162090 A1 7/2007 Penner  
 2007/0179583 A1 8/2007 Goetzinger et al.  
 2007/0191904 A1 8/2007 Libbus et al.  
 2007/0208390 A1 9/2007 Von Arx et al.  
 2007/0247565 A1 10/2007 Sasiaki et al.  
 2007/0250126 A1 10/2007 Maile et al.  
 2007/0274565 A1 11/2007 Penner  
 2007/0282413 A1 12/2007 Tockman et al.  
 2007/0282415 A1 12/2007 Tockman et al.  
 2008/0071178 A1 3/2008 Greenland et al.  
 2008/0071248 A1 3/2008 Delgado et al.  
 2008/0071339 A1 3/2008 Stalker et al.  
 2008/0108904 A1 5/2008 Heil  
 2008/0176271 A1 7/2008 Silver et al.  
 2008/0275350 A1 11/2008 Liao et al.  
 2008/0283066 A1 11/2008 Delgado et al.  
 2009/0054793 A1 2/2009 Nunez et al.  
 2009/0171274 A1 7/2009 Harlev et al.  
 2010/0016840 A1 1/2010 Stahmann et al.  
 2010/0210923 A1 8/2010 Li et al.

EP 1068836 1/2001  
 EP 1488735 6/2007  
 GB 2333044 7/1999  
 JP H(11)-089942 4/1999  
 JP 2000-507142 6/2000  
 JP 2001-061790 3/2001  
 JP 2006-500991 1/2006  
 WO WO 83/03348 10/1983  
 WO WO 99/34731 7/1999  
 WO WO 00/16686 3/2000  
 WO WO 00/59376 10/2000  
 WO WO 01/67989 9/2001  
 WO WO 01/87137 11/2001  
 WO WO 2004/024034 3/2004  
 WO WO 2004/110263 12/2004  
 WO WO 2005/058202 6/2005  
 WO WO 2005/066849 7/2005  
 WO WO 2005/067817 7/2005  
 WO WO 2006/062725 6/2006  
 WO WO 2007/057739 5/2007  
 WO WO 2007/062299 5/2007  
 WO WO 2007/082115 7/2007  
 WO 2008002654 1/2008  
 WO WO 2008/034077 3/2008  
 WO WO 2008/057720 5/2008  
 WO WO2008/060197 5/2008  
 WO WO 2008/144191 11/2008  
 WO 2009006610 1/2009

## OTHER PUBLICATIONS

Lanning & Shandas, "Development and Validation of Implantable Sensors for Monitoring Function of Prosthetic Heart Valves: In Vitro Studies", *Medical & Biological Engineering & Computing*, Jul. 2003, vol. 41, issue 4, pp. 416-424.

Sheth et al. "Subacute Thrombosis and Vascular Injury Resulting From Slotted-Tube Nitinol and Stainless Steel Stents in a Rabbit Carotid Artery Model" *Circulation* 1996, 94: 1733-1740.

Stone et al. "Paclitaxel-Eluting Stents vs. Vascular Brachytherapy for In-Stent Restenosis Within Bare-Metal Stents" *JAMA* 295(11): 1253-1263, Mar. 15, 2006.

Wenaweser et al. "Stent thrombosis following baremetal stent implantation: success of emergency percutaneous coronary intervention and predictors of adverse outcome" *European Heart Journal* 26: 1180-1187 2005.

Goodall, Eleanor V. et al., "Position-Selective Activation of Peripheral Nerve Fibers with a Cuff Electrode", *IEEE Transactions on Biomedical Engineering*, IEEE Service Center, Piscataway, NJ, US, vol. 43, No. 8, Aug. 1, 1996.

International Search Report and Written Opinion issued in PCT/US2010/020756, mailed Sep. 27, 2010.

Invitation to Pay Fees and Partial Search Report issued in PCT/US2010/020756, mailed May 12, 2010.

Mullins, C.E. et al., "Implantation of Balloon-Expandable Intravascular Grafts by Catheterization in Pulmonary Arteries and Systemic Veins", *Circulation*, 1988, vol. 77, pp. 188-199.

\* cited by examiner

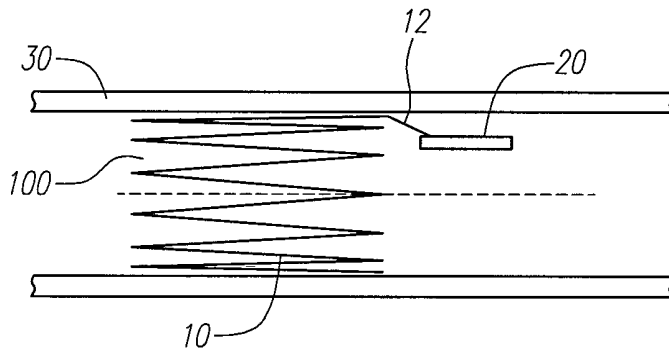

FIG. 1A

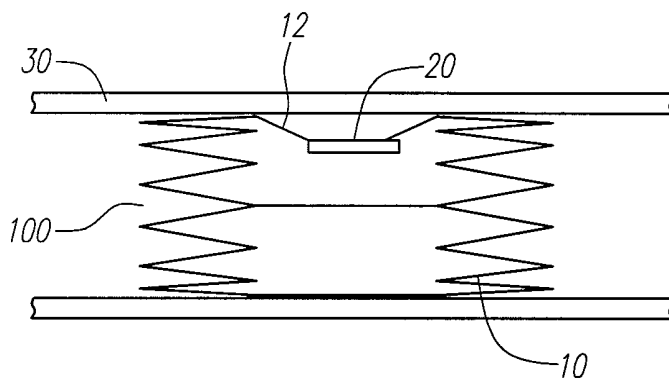

FIG. 1B

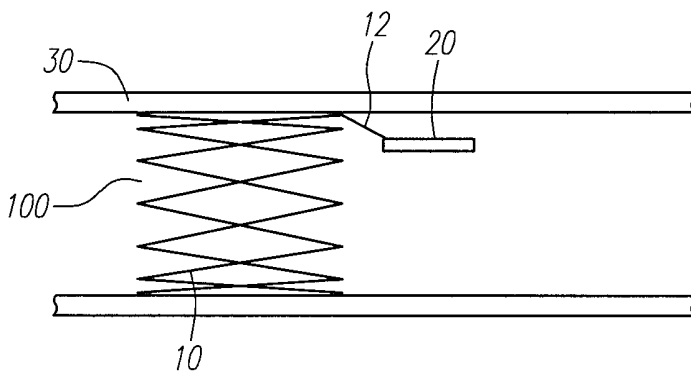

FIG. 1C

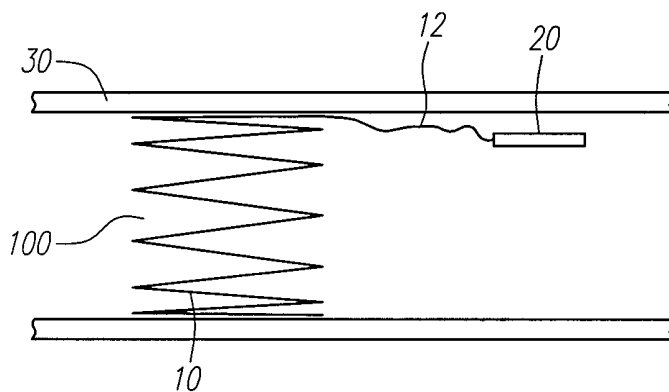

FIG. 1D

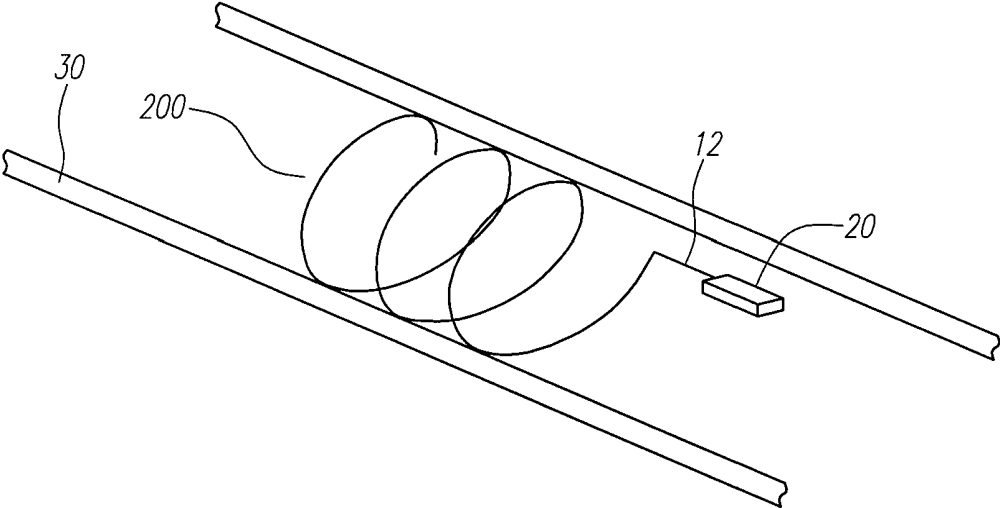

FIG. 2A

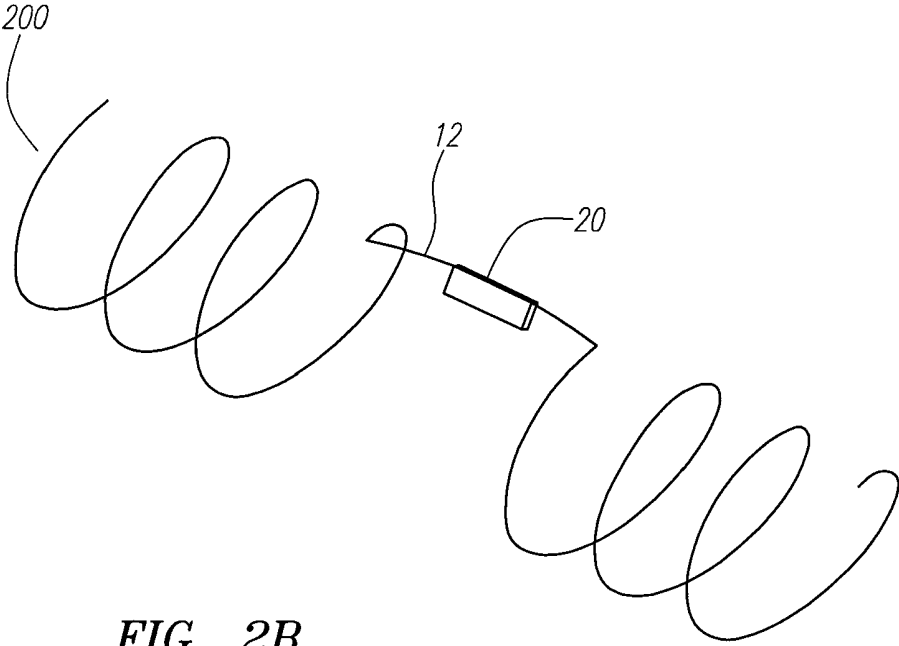

FIG. 2B

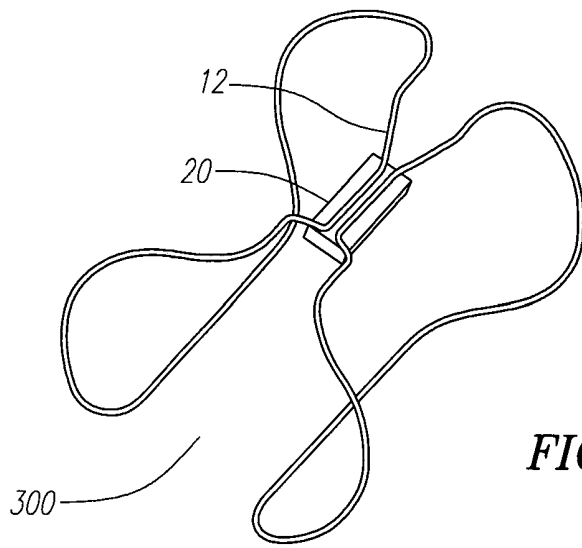

FIG. 3A

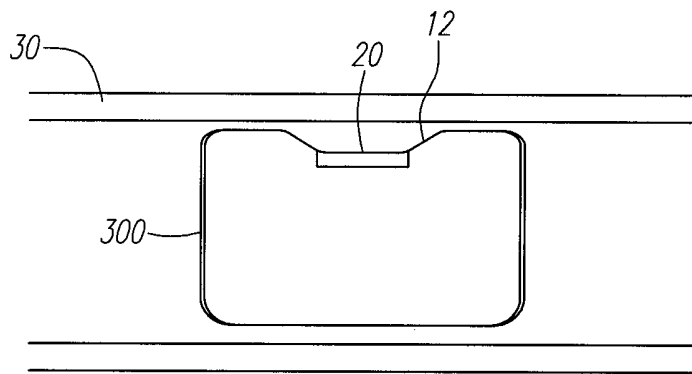

FIG. 3B

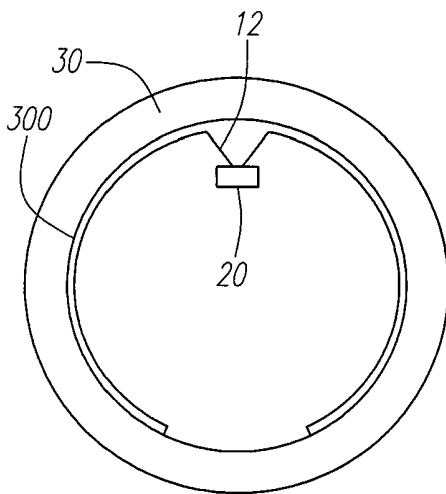

FIG. 3C

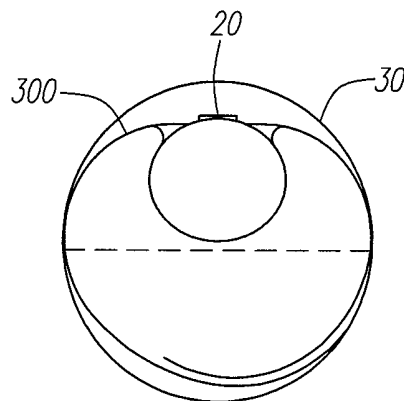

FIG. 3D

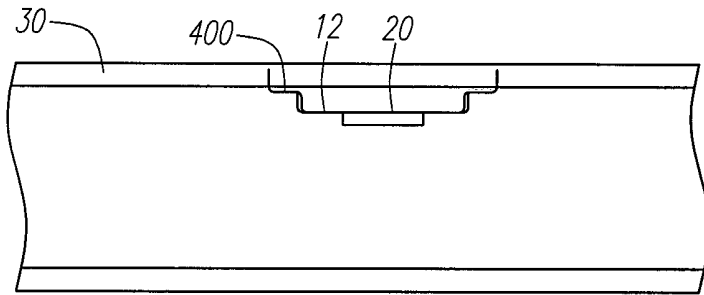

FIG. 4A

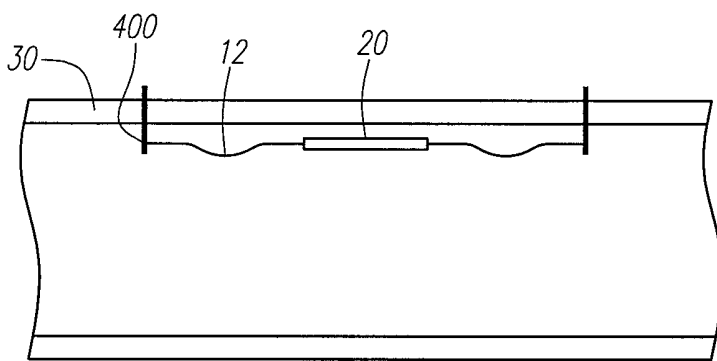

FIG. 4B

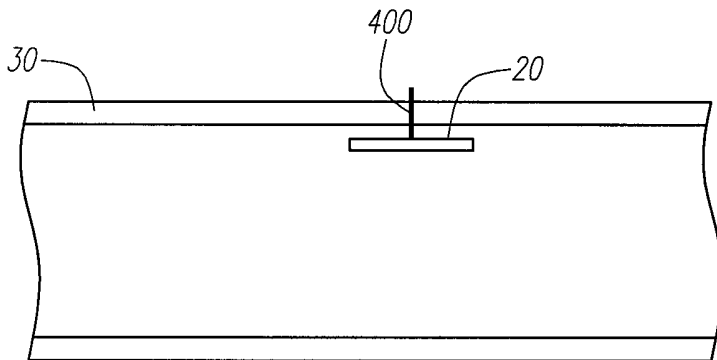

FIG. 4C

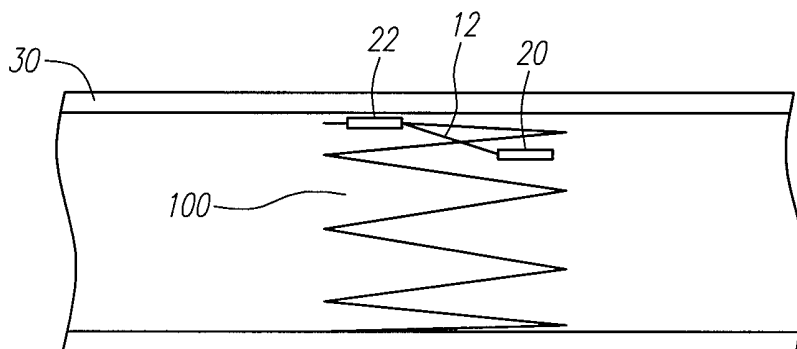

FIG. 5

## DEVICES FOR FIXING A SENSOR IN A LUMEN

### CROSS-REFERENCE TO RELATED APPLICATION

This application is a continuation of U.S. patent application Ser. No. 11/034,502, filed on Jan. 12, 2005, which claims priority under 35 U.S.C. §119 to U.S. Provisional Patent Application Ser. No. 60/536,580, entitled "Device for Fixing a Sensor in a Lumen," filed on Jan. 13, 2004, each of which are expressly incorporated herein by reference in their entirety.

### TECHNICAL FIELD

The present invention relates to field of medical devices and more specifically to a device for positioning a sensor in a lumen.

### BACKGROUND

The use of sensors in body lumens is well known. For example, U.S. Pat. No. 4,485,813 describes a sensor that can be permanently implanted in a specific location within the human body in an implantable medical device such as a pacemaker. In other applications sensors are implanted alone in a body lumen. U.S. Pat. Nos. 6,645,143, 6,053,873, 6,442,413 and United States Publication Serial No. 2002/0188207 describe medical monitoring sensors designed to be implanted in the vascular system and are capable of sensing and transmitting via a telemetry link to an external monitor.

The implanted sensors are utilized for monitoring physical, chemical or physiological parameters in the body. The aim of such sensors is to accurately monitor the desired parameter.

The position of the sensor within the lumen can influence the accuracy of the measurement. Positioning of a sensor facing a lumen wall can alter the sensing ability. Furthermore, positioning of a sensor pressing against the lumen wall in blood vessels may encourage responses, such as neo-intimal growth, which can influence and/or impact the long and short term accuracy of measurements.

United States Publication Serial No. 2002/0188207 discloses a device and method for anchoring a sensor at the center of the lumen. This concept addresses the issue of tissue growth. However, it is problematic to axially align multiple sensors in the same vicinity of a lumen, since a first sensor would block the further sensor(s) from blood flow through the lumen. Thus, it is desirable, and often functionally necessary, to radially and/or circumferentially off-set the sensors of a multiple sensor arrangement, so that they are not coaxially aligned. On the other hand, it is desirable, and often functionally necessary, to operably connect the individual sensors of a multiple sensor arrangement.

There are several medical procedures that require insertion of catheters or other devices through a body lumen and especially through the vascular system, for example, Swan-Ganz catheter to the pulmonary artery for monitoring hemodynamic parameters. Thus, a sensor implantation device should not prevent accessibility to a desired location within the vascular system.

### SUMMARY

One embodiment of the invention is an apparatus for positioning at least one sensor in a body lumen, the body lumen having a wall, the apparatus including a fixation element, a sensor, and a connecting element that connects the sensor to

the fixation element. The connecting element extends at least partially into the lumen so that the sensor is located radially inward from the lumen wall. Other and further embodiments and aspects of the invention are disclosed and described herein.

### BRIEF DESCRIPTION OF THE DRAWINGS

The present invention will be more fully understood and appreciated from the following detailed description taken in conjunction with the figures, in which:

FIGS. 1A-1D are schematic illustrations of a device having a stent-like configured fixation element according to one an embodiment of the invention.

FIGS. 2A-2B are schematic illustrations of a device having a coiled configured fixation element according to another embodiment of the invention.

FIGS. 3A-3D are schematic illustrations of a device having a wing configured fixation element according to yet another embodiment of the invention.

FIGS. 4A-4C are schematic illustrations of a device having a hook configured fixation element according to still another embodiment of the invention.

FIG. 5 is a schematic illustration of a device having two implants according to a still further embodiment of the invention.

### DETAILED DESCRIPTION

The devices disclosed in the following detailed description enable positioning of an implant such as a sensor, a drug reservoir, or other known and/or convenient device within a lumen at a location which is between the inner lumen wall and the lumen center.

In one embodiment, the device includes a fixation part and an implant that is positioned between the lumen wall and the center of the lumen. The implant can be directly connected to the fixation part. The device can further include a connecting element for connecting between the fixation part and the implant and/or for positioning the implant at the desired location. The implant can be a sensor such as, for example, a pressure sensor that is implanted in blood vessels for monitoring blood pressure or any other known and/or convenient device. However, any known and/or convenient sensor can be used, including, but not limited to, a flow sensor, a radiation sensor, a temperature sensor, an electrical impedance sensor, other physical measurement sensor, an optical sensor for monitoring Hemoglobin concentrations and/or glucose, concentrations or any other measurement, or any type of sensor for monitoring chemical species and/or composition, and/or an electrochemical sensor for monitoring various compounds within the bloods, for example, calcium, potassium, sodium and/or any other measurable compound, molecule, atom, and/or ion.

In alternate embodiments, the device can further include a second implant located either in contact with the wall or at the vicinity of the wall or in any other convenient location within a lumen. The second implant can be a second sensor such as, for example, a flow sensor for monitoring flow in the cardiovascular system or an energy source such as a battery or any other known and/or convenient device. The second implant can be connected to the first implant. For example, a first implant which is a sensor can be electrically connected, using an isolated electric wire, to a second implant which is an energy source such as battery for enabling energy transfer from the energy source to the sensor.

In one embodiment, a first implant, which can be a sensor, can be located between the lumen wall and the center of the lumen and a second implant, which can be an energy source, can be located in contact with the lumen wall and electrically connected to the sensor. This configuration enables miniaturizing of the first implant since the energy source is not a part of the sensor.

The insertion of the device into a body lumen can be performed via a catheterization procedure. The device can be mounted on a delivery system, in a compressed configuration so as to enable navigation through the lumen, and delivered through the lumen to the desired deployment site. At the desired deployment site the expandable technique and/or any other known and/or convenient method and/or mechanism.

Other techniques for inserting a device into a lumen, such as making an incision in the lumen and suturing the device at the desired location can be applied. Additionally, the device can be connected to other implants.

Reference is now made to FIGS. 1A-1D illustrating a device that includes a fixation element having a stent-like configuration according to an embodiment of the invention. The devices shown in the embodiments include a fixation element 100, a connecting element 12 and a sensor 20. For convenience and clarity, the lumen 30 is shown in cross-section.

In the embodiment shown in FIG. 1A, fixation element 100 can be manufactured from a wire, a laser cut tube or a chemical etched tube or sheet made of metal, for example Nickel-Titanium alloy, stainless steel titanium, cobalt-based alloy, or a polymer including a shape memory polymer with or without the addition of radio-opaque material e.g. barium sulfate or can be manufactured from any known and/or convenient material using any known and/or convenient method and having any convenient shape. In the embodiment shown in FIG. 1A, the struts 10 cross section can be round, oval, rectangular or any convenient shape. In the embodiment shown in FIG. 1A, the struts are arranged in a zigzag configuration. However in alternate embodiments, the struts can have any convenient configuration. The thickness of struts 10 is in the range of 0.05-0.5 mm. However in alternate embodiments, various other thicknesses can be used. The struts can further include ridges or hooks for preventing migration within the lumen.

FIG. 1A shows fixation element 100 having a radial zigzag configuration that is in contact with the inner side of the lumen wall. The sensor 20 can be connected to a connecting element 12 for connecting sensor 20 to fixation element 100 and for positioning sensor 20 at a desired location distanced from the lumen wall. The sensor 20 can be located between the lumen wall and the center of the lumen. In some embodiments, the sensor can be distanced from the lumen wall between 0.05 mm and 0.8r wherein r is the lumen radius. For example, for a blood vessel having radius of r=10 mm the sensor can be positioned at a distance of 0.05 to 8 mm from the vessel wall.

In some embodiments, connecting element 12 can be made of metal such as Nickel-Titanium alloy, stainless steel, titanium, cobalt-based alloy, or using tantalum, gold, platinum or platinum-iridium for enhanced radio-opacity, or a polymer including a shape memory polymer with or without the addition of radio-opaque material e.g. barium sulfate, and/or composed of any known and/or convenient material and or made in any know and/or convenient shape using any known and/or convenient method.

In some embodiments, connecting element 12 can be rigid so as to maintain sensor 20 at constant position or can be flexible as illustrated in FIG. 1D, so as to enable movement of

the sensor within the lumen. In alternate embodiments, sensor 20 can be connected directly to strut 10 of fixation element 100. In selected embodiments, the sensor 20, can be located in a position proximal to the fixation element 100 to reduce neo intima and cell proliferation.

In alternate embodiments, sensor 20 can be oriented parallel, perpendicular or at any other angle to the lumen wall. In still further alternate embodiments, the active face of the sensor 20 can be oriented towards the lumen center, the lumen wall or tangential and/or in any other convenient location.

Reference is now made to FIG. 1B, illustrating one configuration of the device having two fixation elements 100 at both sides, proximal and distal to the sensor 20. In the embodiment shown in FIG. 1B, proximal and distal fixation elements 100 can be connected at one or more points and sensor 20 can be connected to fixation element 100 by one connecting element. That is, sensor 20 can be connected to the distal or proximal strut or can be connected to the distal and proximal strut. Sensor 20 can be oriented parallel, perpendicular or at any other angle to the lumen wall. The active face of the sensor 20 can be oriented towards the lumen center, the lumen wall or tangential or in any convenient orientation. In some embodiments, connecting element 12 can be rigid so as to maintain sensor 20 at constant position or can be flexible so as to allow movement of sensor 20.

Reference is now made to FIG. 1C, illustrating an alternate configuration of fixation element 100 in which the struts are configured in a closed cell zigzag arrangement. However in some embodiments, any known and/or convenient strut configuration can be used. Furthermore, it will be appreciated that other configurations can be used.

Reference is now made to FIGS. 2A-2B illustrating a device having a coiled fixation element 200 according to an embodiment of the invention. The device can include coiled configured fixation element 200, connecting element 12 and sensor 20. For clarity and convenience the lumen 30 is shown in cross-sectional view.

The coiled fixation element 200 can be manufactured from a wire, a laser cut tube or a chemical etched tube or sheet made of metal, for example Nickel-Titanium alloy, stainless steel titanium, cobalt-based alloy, or a polymer including a shape memory polymer with or without the addition of radio-opaque material e.g. barium sulfate or composed of any known and/or convenient material, in any convenient shape and/or using any known and/or convenient method. The fixation element cross-section may be round, oval, rectangular etc. The thickness of strut 10 of coiled fixation element 200 is in the range of 0.05-0.5 mm. Additionally in selected embodiments, the strut can further include ridges or hooks for preventing migration within the lumen.

The coiled fixation element 200 configuration can be radial and can be in contact with the lumen wall. The sensor 20 can be connected to a connecting element 12 for connecting sensor 20 to fixation element 200 and/or for positioning sensor 20 at a desired location distanced from the lumen wall. In alternate embodiments, sensor 20 can be connected directly to coil fixation element 200. In various embodiments, the sensor can be located between the lumen wall and the center of the lumen. In alternate embodiments the sensor can be distanced from the lumen wall between 0.05 mm and 0.8r wherein r is the lumen radius. However in alternate embodiments, the sensor can be located at any convenient distance from the lumen wall. For example, for blood vessel having radius of r=10 mm the sensor can be positioned at a distance of 0.05 to 8 mm of the vessel wall. In selected embodiments, connecting element 12 can be made of metal such as Nickel-Titanium alloy, stainless steel titanium, cobalt-based alloy, or using

tantalum, gold, platinum or platinum-iridium for enhanced radio-opacity, or a polymer including a shape memory polymer with or without the addition of radio-opaque material e.g. barium sulfate, or any known and/or convenient material, in any convenient shape and manufactured in any known and/or convenient manner. In selected embodiments, connecting element **12** can be rigid so as to maintain sensor **20** at constant position or can be flexible so as to allow movement of sensor **20**.

The sensor **20** may be oriented parallel, perpendicular or at any other angle to the lumen wall. The active face of the sensor **20** can be oriented towards the lumen center, the lumen wall, tangential to the lumen wall or at any other convenient angle within the lumen. In selected embodiments, sensor **20** can be oriented parallel, perpendicular or at any other angle to the lumen wall.

Reference is now made to FIG. 2B, illustrating a device having coiled fixation element **200** at both sides, of sensor **20**. In the embodiment shown in FIG. 2B, proximal and distal coiled fixation element **200** can be connected at one or more points. Connecting element **12** can be rigid so as to maintain sensor **20** at constant position or can be flexible so as to allow movement of sensor **20**. Additionally, sensor **20** can be oriented parallel, perpendicular or at any other angle to the lumen wall. The active face of the sensor **20** can be oriented towards the lumen center, the lumen wall or tangential. Furthermore, sensor **20** can be oriented parallel, perpendicular or at any other angle to the lumen wall. As will be apparent to those skilled in the art, other configurations can be used.

Reference is now made to FIGS. 3A-3D, illustrating a device having a wing-configured fixation element. In the embodiments shown in FIGS. 3A-3D, the device includes wing-configured fixation element **300**, connecting element **12** and a sensor **20**. For convenience and clarity, the lumen **30** is shown in cross-sectional view.

The wing-configured fixation element **300** may be manufactured from a wire, a laser cut tube or a chemical etched tube or sheet made of metal, for example Nickel-Titanium alloy, stainless steel titanium, cobalt-based alloy, or a polymer including a shape memory polymer with or without the addition of radio-opaque material, e.g. barium sulfate, or can be comprised of any known and/or convenient material, can be manufactured using any known and/or convenient shape and can be made using any known and/or convenient method.

The struts **10** of wing configured fixation element **300** may have a round, oval, rectangular etc. cross section. The thickness of struts **10** is in the range of 0.05-0.5 mm. The thickness of the struts may be any convenient thickness. Additionally, the struts can further include ridges or hooks for preventing migration within the lumen.

FIG. 3A is a three dimensional view of the device having wing configured fixation element **300** and FIGS. 3B and 3C illustrate longitudinal and lateral cross sections, respectively.

The sensor **20** may be connected to a connecting element **12** for connecting sensor **20** to fixation element **300** and for positioning sensor **20** at a desired location distanced from the lumen wall. In other embodiment sensor **20** can be connected directly to fixation element **300**. The sensor can be located between the lumen wall and the center of the lumen. In one embodiment the sensor can be distanced from the lumen wall between 0.05 mm and 0.6r wherein r is the lumen radius. For example, for a blood vessel having radius of r=10 mm the sensor can be positioned at a distance of 0.05 to 8 mm off the vessel wall. However in alternate embodiments, the sensor can be located at any convenient location within the lumen. Additionally, connecting wire **12** can be made of metal such as Nickel-Titanium alloy, stainless steel titanium, cobalt-

based alloy, or using tantalum, gold, platinum or platinum-iridium for enhanced radio-opacity, or a polymer including a shape memory polymer with or without the addition of radio-opaque material e.g. barium sulfate, or any known and/or convenient material, made in any convenient shape using any known and/or convenient manufacturing process.

In alternate embodiments, connecting element **12** can be made of metal such as Nickel-Titanium alloy, stainless steel titanium, a polymer or any known and/or convenient material. The connecting element **12** can be rigid so as to maintain sensor **20** at constant position or can be flexible so as to enable movement of the sensor within the lumen. In alternate embodiments, sensor **20** can be connected directly to fixation element **300**.

In the embodiments shown in FIGS. 3A-3C, sensor **20** can be oriented parallel, perpendicular or at any other angle to the lumen wall. The active face of the sensor **20** can be oriented towards the lumen center, the lumen wall, tangential to the lumen wall or at any other convenient angle.

FIG. 3D illustrates a lateral cross section of another configuration of the wing fixation element **300**. In the configuration shown in FIG. 3D, the sensor is at the same level as the strut. In those embodiments in which the struts **10** are made of superelastic Nickel-Titanium alloy, intermediate levels of expansion can be implemented such that the predetermined distances of the sensor from the vessel wall can be achieved.

Reference is now made to FIGS. 4A-4C, illustrating a device having a hook configured fixation element according to an embodiment of the invention. The device includes hook configured fixation element **400**, connecting element **12** and a sensor **20**. Cross section of lumen **30**, for example a blood vessel, is shown.

Fixation element **400** can be manufactured from a wire, a laser cut or a chemical etched tube or sheet made of metal, for example Nickel-Titanium alloy, stainless steel titanium, cobalt-based alloy, or a polymer including a shape memory polymer with or without the addition of radio-opaque material e.g. barium sulfate or of any known and/or convenient material, can be manufactured in any convenient shape using any known and/or convenient method of manufacture. The strut of fixation element **400** cross section can be round, oval, rectangular or have any convenient shape. The thickness of struts is in the range of 0.05-1 mm. The struts can have any convenient thickness and/or dimensions. Additionally, the struts can further include ridges or hooks for anchoring fixation element **400** within the lumen and preventing migration within the lumen.

FIG. 4A shows a device having a hook configured fixation element **400** that is hooked into the lumen wall at least at two points. Hooking can be at the longitudinal axis of the lumen as shown in FIG. 4A or at the transverse axis (not shown).

The sensor **20** can be connected to a connecting wire **12**, which is configured so as to distance the sensor from the lumen wall. The connecting wire **12** is connected to the fixation element **400**. The sensor can be located between the lumen wall and the center of the lumen. In one embodiment the sensor can be distanced from the lumen wall between 0.05 mm and 0.8r wherein r is the lumen radius. For example, for a blood vessel having radius of r=10 mm the sensor can be positioned at a distance of 0.05 to 8 mm of the vessel wall. However in alternate embodiments, the sensor can be located at any convenient location within the lumen.

Connecting element **12** can be made of metal such as Nickel-Titanium alloy, stainless steel titanium, cobalt-based alloy, or using tantalum, gold, platinum or platinum-iridium for enhanced radio-opacity, or a polymer including a shape memory polymer with or without the addition of radio-

opaque material e.g. barium sulfate or any known and/or convenient material, can have any convenient shape and can be manufactured using any convenient manufacturing process. Connecting element 12 can be rigid so as to maintain sensor 20 at constant position or can be flexible as illustrated in FIG. 4B, so as to enable movement of the sensor within the lumen. In other embodiment sensor 20 can be connected directly to fixation element 400.

The sensor 20 can be oriented parallel, perpendicular or at any other angle to the lumen wall. The active face of the sensor 20 can be oriented towards the lumen center, the lumen wall, tangential to the lumen wall or at any other convenient angle.

Reference is now made to FIG. 4C, illustrating another configuration of fixation element 400 in which the fixation element 400 is inserted in the lumen similarly to the insertion of a drawing pin. The sensor 20 can be directly connected to fixation element 400 or connected via a connecting wire.

The sensor 20 can be oriented parallel, perpendicular or at any other angle to the lumen wall. The active face of the sensor 20 can be oriented towards the lumen center, the lumen wall, tangential to the lumen wall or any other convenient angle. Additionally, it will be appreciated that other configurations can be used.

Reference is now made to FIG. 5 which is a schematic illustration of a device having two implants according to an embodiment of the invention. The device includes a fixation element 100, a first implant 20, a second implant 22, and a connecting element 12. For convenience and clarity, the lumen, which can be a blood vessel, is shown in cross-section.

It will be appreciated that fixation element 100 can have any other configuration such as, for example, coil, wing, hook and/or any other known and or convenient configuration.

A first implant 20 may be located between the lumen wall and the center of the lumen. First implant 20 can be distanced from the lumen wall between 0.05 mm and 0.8r wherein r is the lumen radius. For example, for a blood vessel having radius of r=10 mm the first implant can be positioned at a distance of 0.05 to 8 mm off the vessel wall. Second implant 22 can be in contact with the lumen wall or distanced from the lumen wall. However in alternate embodiments, the first and second implants can be located at any convenient locations within the lumen and relative to each other.

The first implant 20 and second implant 22 may be connected by connecting element 12. Second implant 22 can be directly connected to fixation element 100 or connected through an additional connecting element.

The connecting element 12 may be made of metal such as Nickel-Titanium alloy, stainless steel titanium, cobalt-based alloy, or using tantalum, gold, platinum or platinum-iridium for enhanced radio-opacity, or a polymer including a shape memory polymer with or without the addition of radio-opaque material e.g. barium sulfate, or of any other known and/or convenient material.

The connecting element 12 may be rigid so as to maintain first implant 20 at constant position or can be flexible so as to enable movement of first implant 20 within the lumen. Connecting element 12 that connects first implant 20 to second implant 22 can be a metallic or a plastic tube that includes an electric wire for enabling electric communication between first and second implants. The connection between first implant 20 and second implant 22 can be achieved using mechanical means, crimp, adhesives, welding or any other convenient mechanism and/or material. In alternate embodiments, the connection between the first implant 20 and second implant 22 can be wireless, wired or made in any other known and/or convenient manner. Furthermore, in embodiments in

which the second implant 22 is physically connected with the first implant and/or the fixation element 100, the connection element can support both the first implant and the second implant. Alternately, each implant can have a separate connection element 12 to connect the implant with the fixation element.

In one embodiment first implant 20 can be a sensor such as pressure sensor and second implant 22 can be an energy source such as a battery. The sensor and the battery can be connected by electric wire for enabling energy transfer from the battery to the sensor.

While the invention is susceptible to various modifications, and alternative forms, specific examples thereof have been shown in the drawings and are herein described in detail. It should be understood, however, that the invention is not to be limited to the particular embodiments or methods disclosed, but to the contrary, the invention is to cover all modifications, equivalents, and alternatives falling within the scope of the appended claims.

What is claimed is:

1. An implantable vascular pressure sensor for sensing blood pressure within a pulmonary artery, the sensor comprising:

a sensor configured to sense blood pressure within the pulmonary artery; and

a fixation element configured to secure the sensor to a wall of the pulmonary artery, wherein, when the fixation element is disposed within the pulmonary artery, the sensor is located between the wall of the pulmonary artery and a center of the pulmonary artery, the fixation element including:

a first wire loop having a first section fixedly attached to, and extending away from, a first portion of the sensor, the first wire loop having a second section making at least one turn, and the first wire loop having a third section returning to the sensor at, and fixedly attached to, a second portion of the sensor different from the first portion, wherein at least a part of each of the first and third sections of the first wire loop is disposed in a first plane, and at least a part of the second section of the first wire loop is disposed in a second plane that intersects the first plane, the first wire loop comprised entirely of a first wire configured to expand from a collapsed position to an expanded position within the pulmonary artery, wherein, in the expanded position of the first wire loop, an outer periphery of the first wire loop is configured to contact and assert a radial force against the wall at a first location within the pulmonary artery; and

a second wire loop having a first section fixedly attached to, and extending away from, a third portion of the sensor different from the first and second portions, the second wire loop having a second section making at least one turn, and the second wire loop having a third section returning to the sensor at, and fixedly attached to, a fourth portion of the sensor different from the first, second, and third portions, wherein at least a part of each of the first and third sections of the second wire loop is disposed in a third plane, and at least a part of the second section of the second wire loop is disposed in a fourth plane that intersects the third plane, the second wire loop comprised entirely of a second wire configured to expand from a collapsed position to an expanded position within the pulmonary artery, wherein, in the expanded position of the second wire loop, an outer periphery of the second

wire loop is configured to contact and assert a radial force against the wall at a second location within the pulmonary artery.

2. The pressure sensor of claim 1, wherein the sensor is laterally offset from the outer periphery of the first and second wire loops such that, in the expanded position, the sensor is located radially inward and spaced a distance apart from the wall of the pulmonary artery.

3. The pressure sensor of claim 1, wherein, when the fixation element is disposed within the pulmonary artery, the sensor is located less than approximately  $0.8r$  away from the wall, wherein  $r$  represents the artery radius.

4. The pressure sensor of claim 1, wherein the first and second wire loops each comprise a single wire loop.

5. The pressure sensor of claim 1, further comprising a first connecting element connecting the first wire loop to the sensor and a second connecting element connecting the second wire loop to the sensor.

6. The pressure sensor of claim 5, wherein the first and second connecting elements are wires.

7. The pressure sensor of claim 5, wherein the first and second connecting elements are flexible.

8. The pressure sensor of claim 5, wherein the first and second connecting elements are rigid.

9. The pressure sensor of claim 1, wherein an active face of the sensor is adapted to be oriented towards a center of the pulmonary artery.

10. The pressure sensor of claim 9, wherein the active face of the sensor is adapted to be oriented parallel to the wall of the pulmonary artery.

11. The pressure sensor of claim 9, wherein the first and second wire loops are coupled to the sensor on a side opposite the active face.

12. The pressure sensor of claim 9, wherein the active face of the sensor is laterally offset from the outer periphery of the first and second wire loops.

13. The pressure sensor of claim 9, wherein the active face of the sensor is laterally aligned with the outer periphery of the first and second wire loops.

14. The pressure sensor of claim 1, wherein the first and second wire loops are formed at least in part of a metal.

15. The pressure sensor of claim 14, wherein the metal includes a nickel-titanium alloy.

16. The pressure sensor of claim 1, wherein the first and second wire loops are formed at least in part of a polymer.

17. The pressure sensor of claim 1, wherein the sensor includes an energy storage device.

18. An implantable vascular pressure sensor for sensing blood pressure within a pulmonary artery, the sensor comprising:

a sensor configured to sense blood pressure within the pulmonary artery; and

a fixation element configured to secure the sensor to a wall of the pulmonary artery, wherein, when the fixation element is disposed within the pulmonary artery, the sensor is located between the wall of the pulmonary artery and a center of the pulmonary artery, the fixation element including:

a first wire loop having a first section fixedly attached to, and extending away from, a first portion of the sensor, the first wire loop having a second section making at least one turn, and the first wire loop having a third section returning to the sensor at, and fixedly attached to, a second portion of the sensor different from the first portion, wherein at least a part of each of the first and third sections of the first wire loop is disposed in a first plane, and at least a part of the second section of the first

wire loop is disposed in a second plane that intersects the first plane, and extending at least in part proximally from the sensor along a longitudinal axis of the pulmonary artery, the first wire loop comprised entirely of a first wire configured to expand from a collapsed position to an expanded position within the pulmonary artery, wherein, in the expanded position of the first wire loop, an outer periphery of the first wire loop is configured to contact and assert a radial force against the wall at a first location within the pulmonary artery proximal to the sensor;

a second wire loop having a first section fixedly attached to, and extending away from, a third portion of the sensor different from the first and second portions, the second wire loop having a second section making at least one turn, and the second wire loop having a third section returning to the sensor at, and fixedly attached to, a fourth portion of the sensor different from the first, second, and third portions, wherein at least a part of each of the first and third sections of the second wire loop is disposed in a third plane, and at least a part of the second section of the second wire loop is disposed in a fourth plane that intersects the third plane, and extending at least in part distally from the sensor along the longitudinal axis of the pulmonary artery, the second wire loop comprised entirely of a second wire configured to expand from a collapsed position to an expanded position within the pulmonary artery, wherein, in the expanded position of the second wire loop, an outer periphery of the second wire loop is configured to contact and assert a radial force against the wall at a second location within the pulmonary artery distal to the sensor.

19. An implantable vascular pressure sensor for sensing blood pressure within a pulmonary artery, the sensor comprising:

a sensor configured to sense blood pressure within the pulmonary artery; and

a fixation element configured to secure the sensor to a wall of the pulmonary artery, wherein, when the fixation element is disposed within the pulmonary artery, the sensor is located between the wall of the pulmonary artery and a center of the pulmonary artery, the fixation element including:

a first anchoring member having a first section fixedly attached to, and extending away from, a first portion of the sensor, the first anchoring member having a second section making at least one turn, and the first anchoring member having a third section returning to the sensor at, and fixedly attached to, a second portion of the sensor different from the first portion, wherein at least a part of each of the first and third sections of the first anchoring member is disposed in a first plane, and at least a part of the second section of the first anchoring member is disposed in a second plane that intersects the first plane, the first anchoring member comprising a single wire loop formed entirely of a first wire configured to expand from a collapsed position to an expanded position within the pulmonary artery, wherein, in the expanded position, an outer periphery of the first anchoring member is configured to contact and assert a radial force against the wall at a first location within the pulmonary artery;

a second anchoring member having a first section fixedly attached to, and extending away from, a third portion of the sensor different from the first and second portions, the second anchoring member having a second section making at least one turn, and the second anchoring member having a third section returning to the sensor at, and

fixedly attached to, a fourth portion of the sensor different from the first, second, and third portions, wherein at least a part of each of the first and third sections of the second anchoring member is disposed in a third plane, and at least a part of the second section of the second anchoring member is disposed in a fourth plane that intersects the third plane, the second anchoring member comprising a single wire loop formed entirely of a second wire configured to expand from a collapsed position to an expanded position within the pulmonary artery, wherein, in the expanded position, an outer periphery of the second anchoring member is configured to contact and assert a radial force against the wall at a second location within the pulmonary artery.

\* \* \* \* \*

专利名称(译)	用于将传感器固定在内腔中的装置		
公开(公告)号	<a href="#">US9149193</a>	公开(公告)日	2015-10-06
申请号	US12/496904	申请日	2009-07-02
[标]申请(专利权)人(译)	REMON医疗TECH		
申请(专利权)人(译)	REMON MEDICAL TECHNOLOGIES LTD.		
当前申请(专利权)人(译)	REMON MEDICAL TECHNOLOGIES LTD		
[标]发明人	WOLINSKY LONE BEN YOSEPH ALON PENNER ABRAHAM		
发明人	WOLINSKY, LONE BEN-YOSEPH, ALON PENNER, ABRAHAM		
IPC分类号	A61B5/02 A61B5/0215 A61B5/00 A61F2/86 A61B5/145 A61F2/82 A61F2/02		
CPC分类号	A61B5/0215 A61B5/0031 A61B5/6882 A61B5/6886 A61F2/86 A61B5/145 A61F2/82 A61F2230/0091 A61F2250/0002		
代理机构(译)	FAEGRE BAKER丹尼尔斯律师事务所		
审查员(译)	德安杰洛, MICHAEL		
优先权	60/536580 2004-01-13 US		
其他公开文献	US20090270742A1		
外部链接	<a href="#">Espacenet</a> <a href="#">USPTO</a>		

摘要(译)

用于将至少一个传感器定位在体腔中的装置，该装置包括固定元件，传感器和将传感器连接到固定元件的连接元件，该连接元件至少部分地延伸到管腔中，使得传感器是从腔的壁径向向内定位。

