



US 20090270742A1

(19) **United States**

(12) **Patent Application Publication**
Wolinsky et al.

(10) **Pub. No.: US 2009/0270742 A1**

(43) **Pub. Date: Oct. 29, 2009**

(54) **DEVICES FOR FIXING A SENSOR IN A LUMEN**

(22) Filed: **Jul. 2, 2009**

Related U.S. Application Data

(75) Inventors: **Lone Wolinsky**, Ramat Gan (IL);
Alon Ben-Yoseph, Amek Yisrael (IL);
Abraham Penner, Tel Aviv (IL)

(63) Continuation of application No. 11/034,502, filed on Jan. 12, 2005, now Pat. No. 7,572,228.

(60) Provisional application No. 60/536,580, filed on Jan. 13, 2004.

Publication Classification

Correspondence Address:
FAEGRE & BENSON LLP
PATENT DOCKETING - INTELLECTUAL PROPERTY (32469)
2200 WELLS FARGO CENTER, 90 SOUTH SEVENTH STREET
MINNEAPOLIS, MN 55402-3901 (US)

(51) **Int. Cl.**
A61B 5/02 (2006.01)

(52) **U.S. Cl.** **600/486**

(57) **ABSTRACT**

Apparatus for positioning at least one sensor in a body lumen, the apparatus including a fixation element, a sensor, and a connecting element that connects the sensor to the fixation element, the connecting element extending at least partially into the lumen so that the sensor is located radially inward from a wall of the lumen.

(73) Assignee: **Remon Medical Technologies Ltd.**, Caesarea (IL)

(21) Appl. No.: **12/496,904**

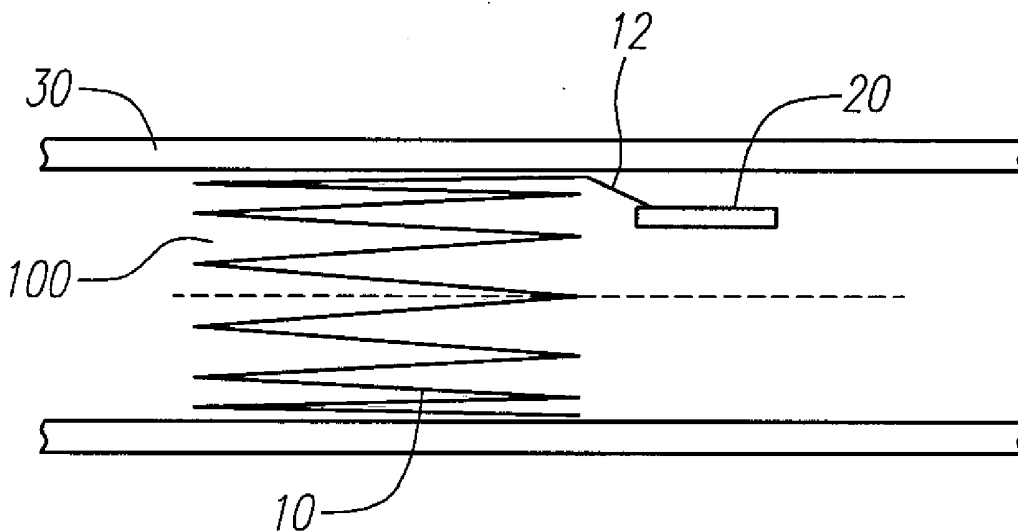

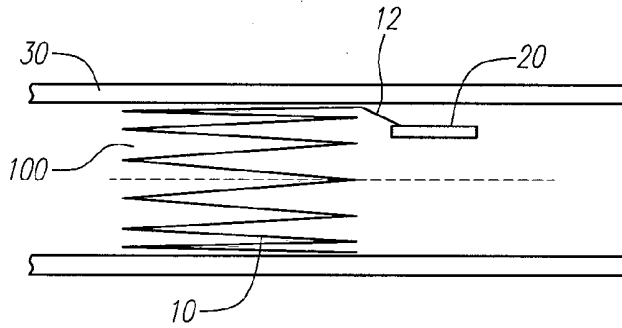

FIG. 1A

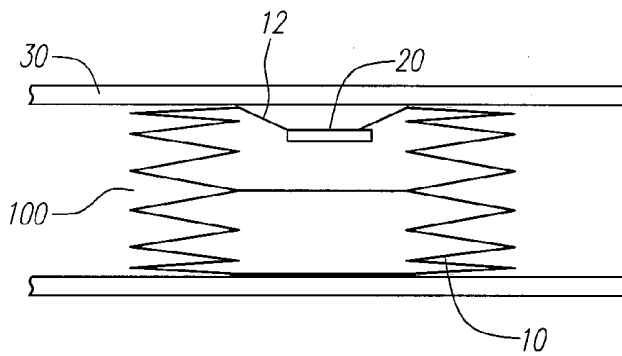

FIG. 1B

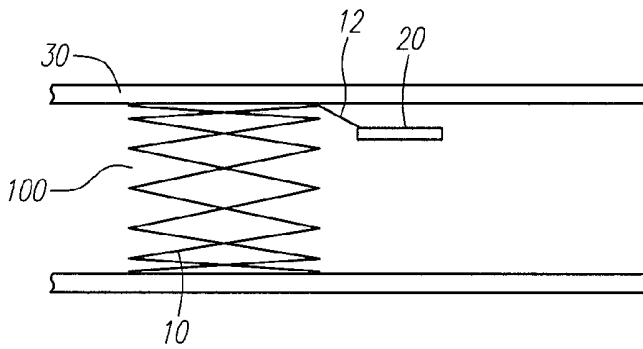

FIG. 1C

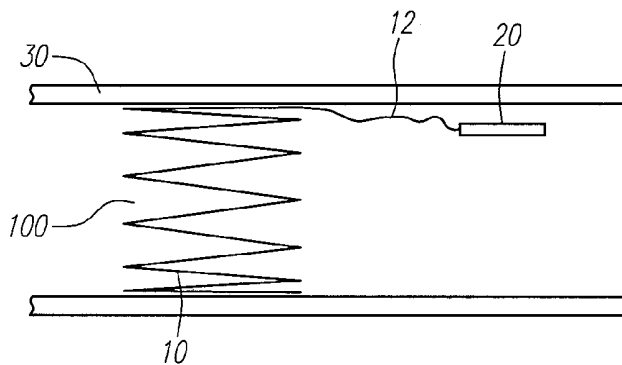

FIG. 1D

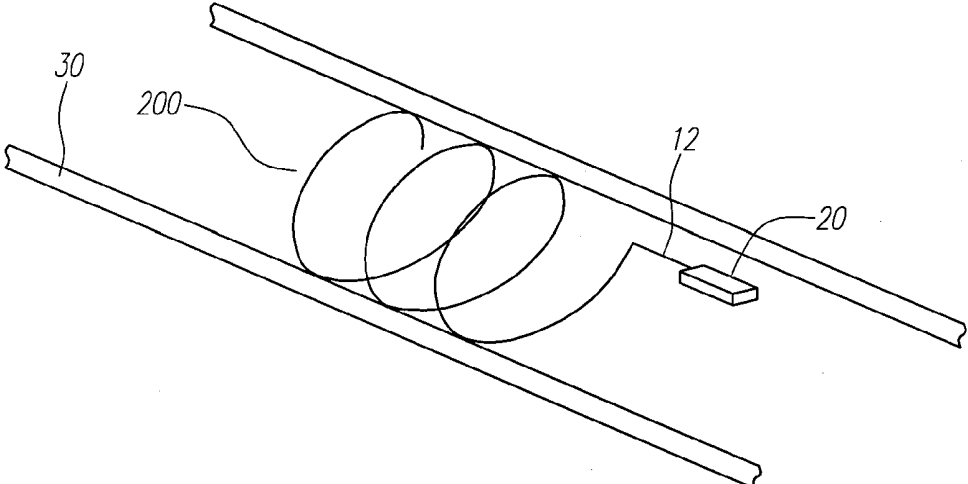

FIG. 2A

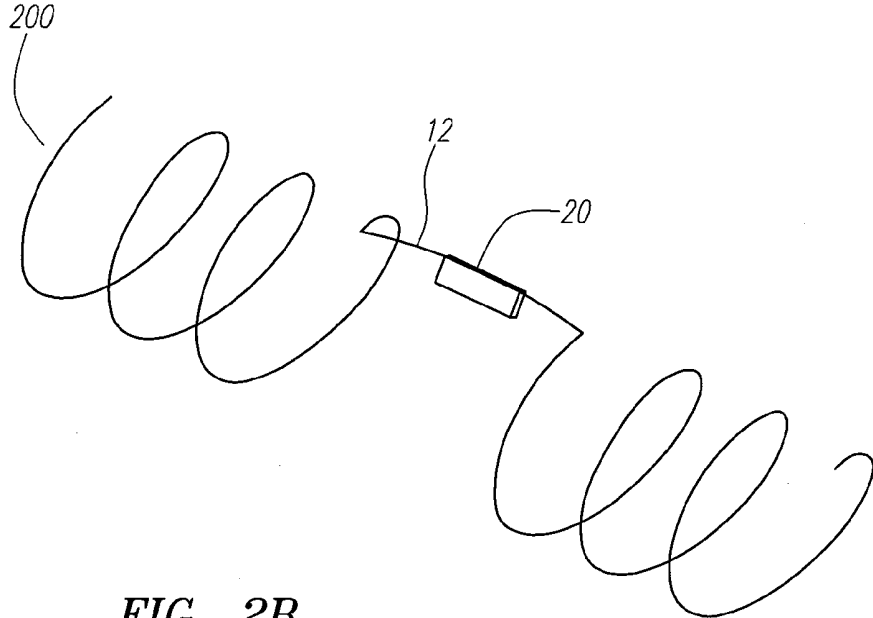

FIG. 2B

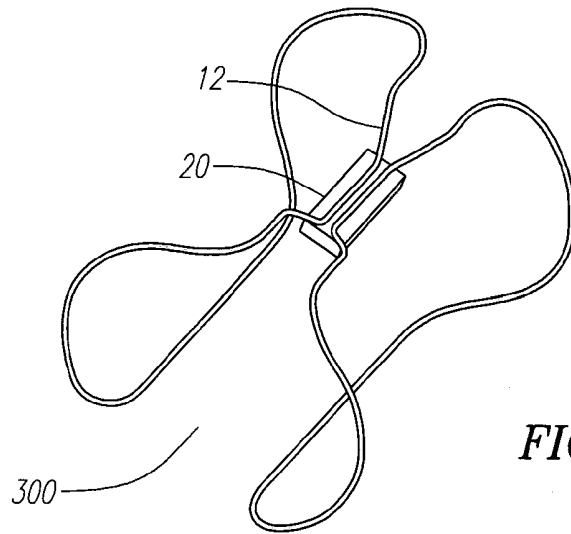

FIG. 3A

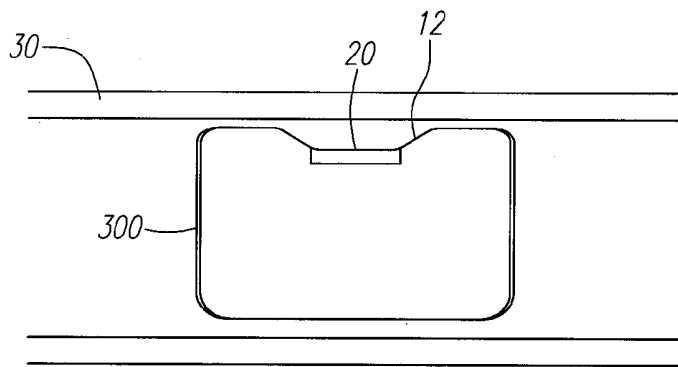

FIG. 3B

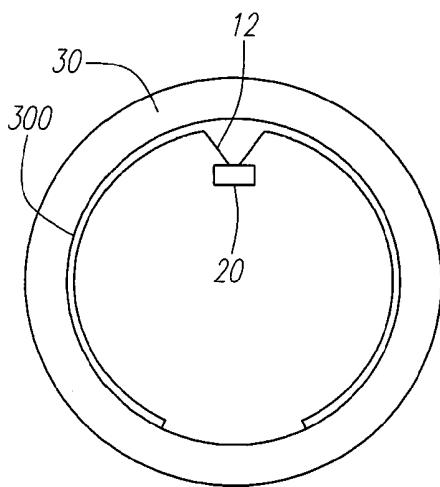

FIG. 3C

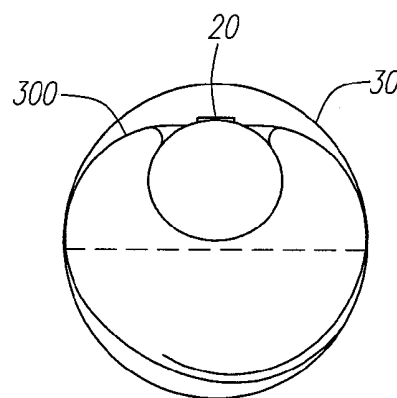

FIG. 3D

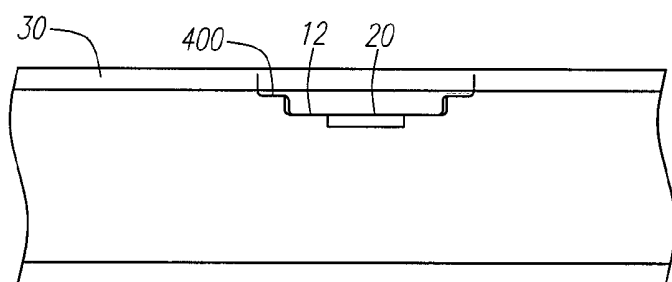

FIG. 4A

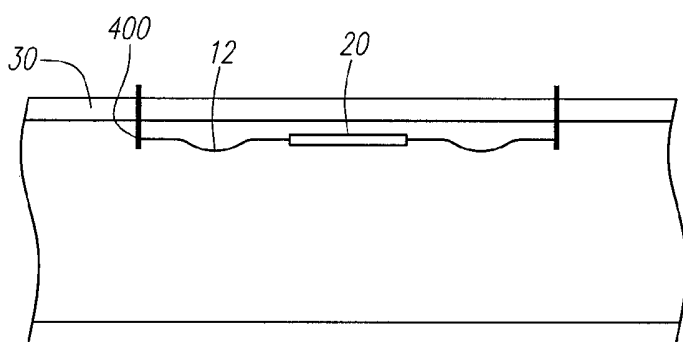

FIG. 4B

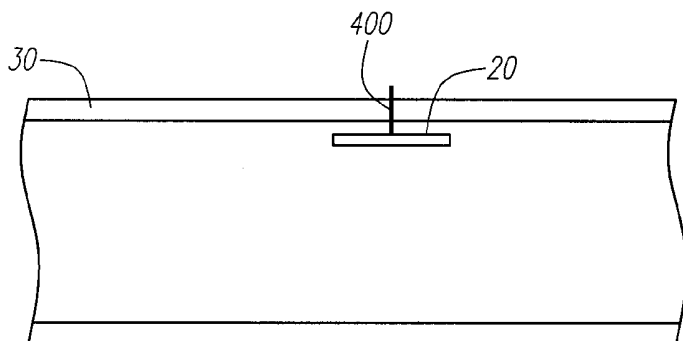

FIG. 4C

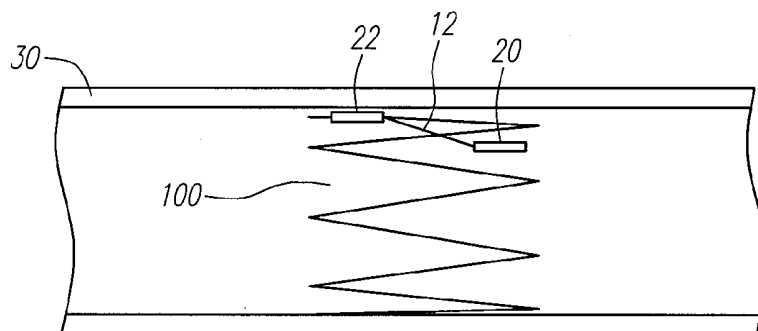

FIG. 5

DEVICES FOR FIXING A SENSOR IN A LUMEN

CROSS-REFERENCE TO RELATED APPLICATION

[0001] This application is a continuation of U.S. patent application Ser. No. 11/034,502, filed on Jan. 12, 2005, which claims priority under 35 U.S.C. §119 to U.S. Provisional Patent Application Ser. No. 60/536,580, entitled "Device for Fixing a Sensor in a Lumen," filed on Jan. 13, 2004, each of which are expressly incorporated herein by reference in their entirety.

TECHNICAL FIELD

[0002] The present invention relates to field of medical devices and more specifically to a device for positioning a sensor in a lumen.

BACKGROUND

[0003] The use of sensors in body lumens is well known. For example, U.S. Pat. No. 4,485,813 describes a sensor that can be permanently implanted in a specific location within the human body in an implantable medical device such as a pacemaker. In other applications sensors are implanted alone in a body lumen. U.S. Pat. Nos. 6,645,143, 6,053,873, 6,442,413 and United States Publication Serial No. 2002/0188207 describe medical monitoring sensors designed to be implanted in the vascular system and are capable of sensing and transmitting via a telemetry link to an external monitor.

[0004] The implanted sensors are utilized for monitoring physical, chemical or physiological parameters in the body. The aim of such sensors is to accurately monitor the desired parameter.

[0005] The position of the sensor within the lumen can influence the accuracy of the measurement. Positioning of a sensor facing a lumen wall can alter the sensing ability. Furthermore, positioning of a sensor pressing against the lumen wall in blood vessels may encourage responses, such as neo-intimal growth, which can influence and/or impact the long and short term accuracy of measurements.

[0006] United States Publication Serial No. 2002/0188207 discloses a device and method for anchoring a sensor at the center of the lumen. This concept addresses the issue of tissue growth. However, it is problematic to axially align multiple sensors in the same vicinity of a lumen, since a first sensor would block the further sensor(s) from blood flow through the lumen. Thus, it is desirable, and often functionally necessary, to radially and/or circumferentially off-set the sensors of a multiple sensor arrangement, so that they are not coaxially aligned. On the other hand, it is desirable, and often functionally necessary, to operably connect the individual sensors of a multiple sensor arrangement.

[0007] There are several medical procedures that require insertion of catheters or other devices through a body lumen and especially through the vascular system, for example, Swan-Ganz catheter to the pulmonary artery for monitoring hemodynamic parameters. Thus, a sensor implantation device should not prevent accessibility to a desired location within the vascular system.

SUMMARY

[0008] One embodiment of the invention is an apparatus for positioning at least one sensor in a body lumen, the body

lumen having a wall, the apparatus including a fixation element, a sensor, and a connecting element that connects the sensor to the fixation element. The connecting element extends at least partially into the lumen so that the sensor is located radially inward from the lumen wall. Other and further embodiments and aspects of the invention are disclosed and described herein.

BRIEF DESCRIPTION OF THE DRAWINGS

[0009] The present invention will be more fully understood and appreciated from the following detailed description taken in conjunction with the figures, in which:

[0010] FIGS. 1A-1D are schematic illustrations of a device having a stent-like configured fixation element according to one an embodiment of the invention.

[0011] FIGS. 2A-2B are schematic illustrations of a device having a coiled configured fixation element according to another embodiment of the invention.

[0012] FIGS. 3A-3D are schematic illustrations of a device having a wing configured fixation element according to yet another embodiment of the invention.

[0013] FIGS. 4A-4C are schematic illustrations of a device having a hook configured fixation element according to still another embodiment of the invention.

[0014] FIG. 5 is a schematic illustration of a device having two implants according to a still further embodiment of the invention.

DETAILED DESCRIPTION

[0015] The devices disclosed in the following detailed description enable positioning of an implant such as a sensor, a drug reservoir, or other known and/or convenient device within a lumen at a location which is between the inner lumen wall and the lumen center.

[0016] In one embodiment, the device includes a fixation part and an implant that is positioned between the lumen wall and the center of the lumen. The implant can be directly connected to the fixation part. The device can further include a connecting element for connecting between the fixation part and the implant and/or for positioning the implant at the desired location. The implant can be a sensor such as, for example, a pressure sensor that is implanted in blood vessels for monitoring blood pressure or any other known and/or convenient device. However, any known and/or convenient sensor can be used, including, but not limited to, a flow sensor, a radiation sensor, a temperature sensor, an electrical impedance sensor, other physical measurement sensor, an optical sensor for monitoring Hemoglobin concentrations and/or glucose, concentrations or any other measurement, or any type of sensor for monitoring chemical species and/or composition, and/or an electrochemical sensor for monitoring various compounds within the bloods, for example, calcium, potassium, sodium and/or any other measurable compound, molecule, atom, and/or ion.

[0017] In alternate embodiments, the device can further include a second implant located either in contact with the wall or at the vicinity of the wall or in any other convenient location within a lumen. The second implant can be a second sensor such as, for example, a flow sensor for monitoring flow in the cardiovascular system or an energy source such as a battery or any other known and/or convenient device. The second implant can be connected to the first implant. For example, a first implant which is a sensor can be electrically

connected, using an isolated electric wire, to a second implant which is an energy source such as battery for enabling energy transfer from the energy source to the sensor.

[0018] In one embodiment, a first implant, which can be a sensor, can be located between the lumen wall and the center of the lumen and a second implant, which can be an energy source, can be located in contact with the lumen wall and electrically connected to the sensor. This configuration enables miniaturizing of the first implant since the energy source is not a part of the sensor.

[0019] The insertion of the device into a body lumen can be performed via a catheterization procedure. The device can be mounted on a delivery system, in a compressed configuration so as to enable navigation through the lumen, and delivered through the lumen to the desired deployment site. At the desired deployment site the expandable technique and/or any other known and/or convenient method and/or mechanism.

[0020] Other techniques for inserting a device into a lumen, such-as making an incision in the lumen and suturing the device at the desired location can be applied. Additionally, the device can be connected to other implants.

[0021] Reference is now made to FIGS. 1A-1D illustrating a device that includes a fixation element having a stent-like configuration according to an embodiment of the invention. The devices shown in the embodiments include a fixation element 100, a connecting element 12 and a sensor 20. For convenience and clarity, the lumen 30 is shown in cross-section.

[0022] In the embodiment shown in FIG. 1A, fixation element 100 can be manufactured from a wire, a laser cut tube or a chemical etched tube or sheet made of metal, for example Nickel-Titanium alloy, stainless steel titanium, cobalt-based alloy, or a polymer including a shape memory polymer with or without the addition of radio-opaque material e.g. barium sulfate or can be manufactured from any known and/or convenient material using any known and/or convenient method and having any convenient shape. In the embodiment shown in FIG. 1A, the struts 10 cross section can be round, oval, rectangular or any convenient shape. In the embodiment shown in FIG. 1A, the struts are arranged in a zigzag configuration. However in alternate embodiments, the struts can have any convenient configuration. The thickness of struts 10 is in the range of 0.05-0.5 mm. However in alternate embodiments, various other thicknesses can be used. The struts can further include ridges or hooks for preventing migration within the lumen.

[0023] FIG. 1A shows fixation element 100 having a radial zigzag configuration that is in contact with the inner side of the lumen wall. The sensor 20 can be connected to a connecting element 12 for connecting sensor 20 to fixation element 100 and for positioning sensor 20 at a desired location distanced from the lumen wall. The sensor 20 can be located between the lumen wall and the center of the lumen. In some embodiments, the sensor can be distanced from the lumen wall between 0.05 mm and 0.8r wherein r is the lumen radius. For example, for a blood vessel having radius of r=10 mm the sensor can be positioned at a distance of 0.05 to 8 mm from the vessel wall.

[0024] In some embodiments, connecting element 12 can be made of metal such as Nickel-Titanium alloy, stainless steel, titanium, cobalt-based alloy, or using tantalum, gold, platinum or platinum-iridium for enhanced radio-opacity, or a polymer including a shape memory polymer with or without the addition of radio-opaque material e.g. barium sulfate,

and/or composed of any known and/or convenient material and or made in any known and/or convenient shape using any known and/or convenient method.

[0025] In some embodiments, connecting element 12 can be rigid so as to maintain sensor 20 at constant position or can be flexible as illustrated in FIG. 1D, so as to enable movement of the sensor within the lumen. In alternate embodiments, sensor 20 can be connected directly to strut 10 of fixation element 100. In selected embodiments, the sensor 20, can be located in a position proximal to the fixation element 100 to reduce neo intima and cell proliferation.

[0026] In alternate embodiments, sensor 20 can be oriented parallel, perpendicular or at any other angle to the lumen wall. In still further alternate embodiments, the active face of the sensor 20 can be oriented towards the lumen center, the lumen wall or tangential and/or in any other convenient location.

[0027] Reference is now made to FIG. 1B, illustrating one configuration of the device having two fixation elements 100 at both sides, proximal and distal to the sensor 20. In the embodiment shown in FIG. 1B, proximal and distal fixation elements 100 can be connected at one or more points and sensor 20 can be connected to fixation element 100 by one connecting element. That is, sensor 20 can be connected to the distal or proximal strut or can be connected to the distal and proximal strut. Sensor 20 can be oriented parallel, perpendicular or at any other angle to the lumen wall. The active face of the sensor 20 can be oriented towards the lumen center, the lumen wall or tangential or in any convenient orientation. In some embodiments, connecting element 12 can be rigid so as to maintain sensor 20 at constant position or can be flexible so as to allow movement of sensor 20.

[0028] Reference is now made to FIG. 1C, illustrating an alternate configuration of fixation element 100 in which the struts are configured in a closed cell zigzag arrangement. However in some embodiments, any known and/or convenient strut configuration can be used. Furthermore, it will be appreciated that other configurations can be used.

[0029] Reference is now made to FIGS. 2A-2B illustrating a device having a coiled fixation element 200 according to an embodiment of the invention. The device can include coiled configured fixation element 200, connecting element 12 and sensor 20. For clarity and convenience the lumen 30 is shown in cross-sectional view.

[0030] The coiled fixation element 200 can be manufactured from a wire, a laser cut tube or a chemical etched tube or sheet made of metal, for example Nickel-Titanium alloy, stainless steel titanium, cobalt-based alloy, or a polymer including a shape memory polymer with or without the addition of radio-opaque material e.g. barium sulfate or composed of any known and/or convenient material, in any convenient shape and/or using any known and/or convenient method. The fixation element cross-section may be round, oval, rectangular etc. The thickness of strut 10 of coiled fixation element 200 is in the range of 0.05-0.5 mm. Additionally in selected embodiments, the strut can further include ridges or hooks for preventing migration within the lumen.

[0031] The coiled fixation element 200 configuration can be radial and can be in contact with the lumen wall. The sensor 20 can be connected to a connecting element 12 for connecting sensor 20 to fixation element 200 and/or for positioning sensor 20 at a desired location distanced from the lumen wall. In alternate embodiments, sensor 20 can be connected directly to coil fixation element 200. In various embodiments, the sensor can be located between the lumen

wall and the center of the lumen. In alternate embodiments the sensor can be distanced from the lumen wall between 0.05 mm and $0.8r$ wherein r is the lumen radius. However in alternate embodiments, the sensor can be located at any convenient distance from the lumen wall. For example, for blood vessel having radius of $r=10$ mm the sensor can be positioned at a distance of 0.05 to 8 mm of the vessel wall. In selected embodiments, connecting element **12** can be made of metal such as Nickel-Titanium alloy, stainless steel titanium, cobalt-based alloy, or using tantalum, gold, platinum or platinum-iridium for enhanced radio-opacity, or a polymer including a shape memory polymer with or without the addition of radio-opaque material e.g. barium sulfate, or any known and/or convenient material, in any convenient shape and manufactured in any known and/or convenient manner. In selected embodiments, connecting element **12** can be rigid so as to maintain sensor **20** at constant position or can be flexible so as to allow movement of sensor **20**.

[0032] The sensor **20** may be oriented parallel, perpendicular or at any other angle to the lumen wall. The active face of the sensor **20** can be oriented towards the lumen center, the lumen wall, tangential to the lumen wall or at any other convenient angle within the lumen. In selected embodiments, sensor **20** can be oriented parallel, perpendicular or at any other angle to the lumen wall.

[0033] Reference is now made to FIG. 2B, illustrating a device having coiled fixation element **200** at both sides, of sensor **20**. In the embodiment shown in FIG. 2B, proximal and distal coiled fixation element **200** can be connected at one or more points. Connecting element **12** can be rigid so as to maintain sensor **20** at constant position or can be flexible so as to allow movement of sensor **20**. Additionally, sensor **20** can be oriented parallel, perpendicular or at any other angle to the lumen wall. The active face of the sensor **20** can be oriented towards the lumen center, the lumen wall or tangential. Furthermore, sensor **20** can be oriented parallel, perpendicular or at any other angle to the lumen wall. As will be apparent to those skilled in the art, other configurations can be used.

[0034] Reference is now made to FIGS. 3A-3D, illustrating a device having a wing-configured fixation element. In the embodiments shown in FIGS. 3A-3D, the device includes wing-configured fixation element **300**, connecting element **12** and a sensor **20**. For convenience and clarity, the lumen **30** is shown in cross-sectional view.

[0035] The wing-configured fixation element **300** may be manufactured from a wire, a laser cut tube or a chemical etched tube or sheet made of metal, for example Nickel-Titanium alloy, stainless steel titanium, cobalt-based alloy, or a polymer including a shape memory polymer with or without the addition of radio-opaque material, e.g. barium sulfate, or can be comprised of any known and/or convenient material, can be manufactured using any known and/or convenient shape and can be made using any known and/or convenient method.

[0036] The struts **10** of wing configured fixation element **300** may have a round, oval, rectangular etc. cross section. The thickness of struts **10** is in the range of 0.05-0.5 mm. The thickness of the struts may be any convenient thickness. Additionally, the struts can further include ridges or hooks for preventing migration within the lumen.

[0037] FIG. 3A is a three dimensional view of the device having wing configured fixation element **300** and FIGS. 3B and 3C illustrate longitudinal and lateral cross sections, respectively.

[0038] The sensor **20** may be connected to a connecting element **12** for connecting sensor **20** to fixation element **300** and for positioning sensor **20** at a desired location distanced from the lumen wall. In other embodiment sensor **20** can be connected directly to fixation element **300**. The sensor can be located between the lumen wall and the center of the lumen. In one embodiment the sensor can be distanced from the lumen wall between 0.05 mm and $0.6r$ wherein r is the lumen radius. For example, for a blood vessel having radius of $r=10$ mm the sensor can be positioned at a distance of 0.05 to 8 mm off the vessel wall. However in alternate embodiments, the sensor can be located at any convenient location within the lumen. Additionally, connecting wire **12** can be made of metal such as Nickel-Titanium alloy, stainless steel titanium, cobalt-based alloy, or using tantalum, gold, platinum or platinum-iridium for enhanced radio-opacity, or a polymer including a shape memory polymer with or without the addition of radio-opaque material e.g. barium sulfate, or any known and/or convenient material, made in any convenient shape using any known and/or convenient manufacturing process.

[0039] In alternate embodiments, connecting element **12** can be made of metal such as Nickel-Titanium alloy, stainless steel titanium, a polymer or any known and/or convenient material. The connecting element **12** can be rigid so as to maintain sensor **20** at constant position or can be flexible so as to enable movement of the sensor within the lumen. In alternate embodiments, sensor **20** can be connected directly to fixation element **300**.

[0040] In the embodiments shown in FIGS. 3A-3C, sensor **20** can be oriented parallel, perpendicular or at any other angle to the lumen wall. The active face of the sensor **20** can be oriented towards the lumen center, the lumen wall, tangential to the lumen wall or at any other convenient angle.

[0041] FIG. 3D illustrates a lateral cross section of another configuration of the wing fixation element **300**. In the configuration shown in FIG. 3D, the sensor is at the same level as the strut. In those embodiments in which the struts **10** are made of superelastic Nickel-Titanium alloy, intermediate levels of expansion can be implemented such that the predetermined distances of the sensor from the vessel wall can be achieved.

[0042] Reference is now made to FIGS. 4A-4C, illustrating a device having a hook configured fixation element according to an embodiment of the invention. The device includes hook configured fixation element **400**, connecting element **12** and a sensor **20**. Cross section of lumen **30**, for example a blood vessel, is shown.

[0043] Fixation element **400** can be manufactured from a wire, a laser cut or a chemical etched tube or sheet made of metal, for example Nickel-Titanium alloy, stainless steel titanium, cobalt-based alloy, or a polymer including a shape memory polymer with or without the addition of radio-opaque material e.g. barium sulfate or of any known and/or convenient material, can be manufactured in any convenient shape using any known and/or convenient method of manufacture. The strut of fixation element **400** cross section can be round, oval, rectangular or have any convenient shape. The thickness of struts is in the range of 0.05-1 mm. The struts can have any convenient thickness and/or dimensions. Additionally, the struts can further include ridges or hooks for anchoring fixation element **400** within the lumen and preventing migration within the lumen.

[0044] FIG. 4A shows a device having a hook configured fixation element 400 that is hooked into the lumen wall at least at two points. Hooking can be at the longitudinal axis of the lumen as shown in FIG. 4A or at the transverse axis (not shown).

[0045] The sensor 20 can be connected to a connecting wire 12, which is configured so as to distance the sensor from the lumen wall. The connecting wire 12 is connected to the fixation element 400. The sensor can be located between the lumen wall and the center of the lumen. In one embodiment the sensor can be distanced from the lumen wall between 0.05 mm and 0.8r wherein r is the lumen radius. For example, for a blood vessel having radius of $r=10$ mm the sensor can be positioned at a distance of 0.05 to 8 mm of the vessel wall. However in alternate embodiments, the sensor can be located at any convenient location within the lumen.

[0046] Connecting element 12 can be made of metal such as Nickel-Titanium alloy, stainless steel titanium, cobalt-based alloy, or using tantalum, gold, platinum or platinum-iridium for enhanced radio-opacity, or a polymer including a shape memory polymer with or without the addition of radio-opaque material e.g. barium sulfate or any known and/or convenient material, can have any convenient shape and can be manufactured using any convenient manufacturing process. Connecting element 12 can be rigid so as to maintain sensor 20 at constant position or can be flexible as illustrated in FIG. 4B, so as to enable movement of the sensor within the lumen. In other embodiment sensor 20 can be connected directly to fixation element 400.

[0047] The sensor 20 can be oriented parallel, perpendicular or at any other angle to the lumen wall. The active face of the sensor 20 can be oriented towards the lumen center, the lumen wall, tangential to the lumen wall or at any other convenient angle.

[0048] Reference is now made to FIG. 4C, illustrating another configuration of fixation element 400 in which the fixation element 400 is inserted in the lumen similarly to the insertion of a drawing pin. The sensor 20 can be directly connected to fixation element 400 or connected via a connecting wire.

[0049] The sensor 20 can be oriented parallel, perpendicular or at any other angle to the lumen wall. The active face of the sensor 20 can be oriented towards the lumen center, the lumen wall, tangential to the lumen wall or any other convenient angle. Additionally, it will be appreciated that other configurations can be used.

[0050] Reference is now made to FIG. 5 which is a schematic illustration of a device having two implants according to an embodiment of the invention. The device includes a fixation element 100, a first implant 20, a second implant 22, and a connecting element 12. For convenience and clarity, the lumen, which can be a blood vessel, is shown in cross-section.

[0051] It will be appreciated that fixation element 100 can have any other configuration such as, for example, coil, wing, hook and/or any other known and or convenient configuration.

[0052] A first implant 20 may be located between the lumen wall and the center of the lumen. First implant 20 can be distanced from the lumen wall between 0.05 mm and 0.8r wherein r is the lumen radius. For example, for a blood vessel having radius of $r=10$ mm the first implant can be positioned at a distance of 0.05 to 8 mm off the vessel wall. Second implant 22 can be in contact with the lumen wall or distanced from the lumen wall. However in alternate embodiments, the

first and second implants can be located at any convenient locations within the lumen and relative to each other.

[0053] The first implant 20 and second implant 22 may be connected by connecting element 12. Second implant 22 can be directly connected to fixation element 100 or connected through an additional connecting element.

[0054] The connecting element 12 may be made of metal such as Nickel-Titanium alloy, stainless steel titanium, cobalt-based alloy, or using tantalum, gold, platinum or platinum-iridium for enhanced radio-opacity, or a polymer including a shape memory polymer with or without the addition of radio-opaque material e.g. barium sulfate, or of any other known and/or convenient material.

[0055] The connecting element 12 may be rigid so as to maintain first implant 20 at constant position or can be flexible so as to enable movement of first implant 20 within the lumen. Connecting element 12 that connects first implant 20 to second implant 22 can be a metallic or a plastic tube that includes an electric wire for enabling electric communication between first and second implants. The connection between first implant 20 and second implant 22 can be achieved using mechanical means, crimp, adhesives, welding or any other convenient mechanism and/or material. In alternate embodiments, the connection between the first implant 20 and second implant 22 can be wireless, wired or made in any other known and/or convenient manner. Furthermore, in embodiments in which the second implant 22 is physically connected with the first implant and/or the fixation element 100, the connection element can support both the first implant and the second implant. Alternately, each implant can have a separate connection element 12 to connect the implant with the fixation element.

[0056] In one embodiment first implant 20 can be a sensor such as pressure sensor and second implant 22 can be an energy source such as a battery. The sensor and the battery can be connected by electric wire for enabling energy transfer from the battery to the sensor.

[0057] While the invention is susceptible to various modifications, and alternative forms, specific examples thereof have been shown in the drawings and are herein described in detail. It should be understood, however, that the invention is not to be limited to the particular embodiments or methods disclosed, but to the contrary, the invention is to cover all modifications, equivalents, and alternatives falling within the scope of the appended claims.

What is claimed is:

1. An implantable vascular pressure sensor for sensing blood pressure within a pulmonary artery, the sensor comprising:

- a sensor configured to sense blood pressure within the pulmonary artery; and
- a fixation element configured to secure the sensor to a wall of the pulmonary artery, the fixation element including:
 - a first wire loop coupled to the sensor, the first wire loop configured to expand from a collapsed position to an expanded position within the pulmonary artery, wherein, in the expanded position of the first wire loop, an outer periphery of the first wire loop is configured to contact and assert a radial force against the wall at a first location within the pulmonary artery; and
 - a second wire loop coupled to the sensor, the second wire loop configured to expand from a collapsed position to an expanded position within the pulmonary artery,

wherein, in the expanded position of the second wire loop, an outer periphery of the second wire loop is configured to contact and assert a radial force against the wall at a second location within the pulmonary artery.

2. The pressure sensor of claim 1, wherein the sensor is laterally offset from the outer periphery of the first and second wire loops such that, in the expanded position, the sensor is located radially inward and spaced a distance apart from the wall of the pulmonary artery.

3. The pressure sensor of claim 1, wherein the fixation element suspends at least part of the sensor inwardly away from the wall such that blood within the pulmonary artery flows between the wall and the sensor.

4. The pressure sensor of claim 1, wherein, when the fixation element is disposed within the pulmonary artery, the sensor is located less than approximately $0.8r$ away from the wall, wherein r represents the artery radius.

5. The pressure sensor of claim 1, wherein the first and second wire loops each comprise a single wire loop.

6. The pressure sensor of claim 1, further comprising a first connecting element connecting the first wire loop to the sensor and a second connecting element connecting the second wire loop to the sensor.

7. The pressure sensor of claim 6, wherein the first and second connecting elements are wires.

8. The pressure sensor of claim 6, wherein the first and second connecting elements are flexible.

9. The pressure sensor of claim 6, wherein the first and second connecting elements are rigid.

10. The pressure sensor of claim 1, wherein an active face of the sensor is oriented towards a center of the pulmonary artery.

11. The pressure sensor of claim 10, wherein the active face of the sensor is oriented parallel to the wall of the pulmonary artery.

12. The pressure sensor of claim 10, wherein the first and second wire loops are coupled to the sensor on a side opposite the active face.

13. The pressure sensor of claim 10, wherein the active face of the sensor is laterally offset from the outer periphery of the first and second wire loops.

14. The pressure sensor of claim 10, wherein the active face of the sensor is laterally aligned with the outer periphery of the first and second wire loops.

15. The pressure sensor of claim 1, wherein the first and second wire loops are formed at least in part of a metal.

16. The pressure sensor of claim 15, wherein the metal includes a nickel-titanium alloy.

17. The pressure sensor of claim 1, wherein the first and second wire loops are formed at least in part of a polymer.

18. The pressure sensor of claim 1, wherein the sensor includes an energy storage device.

19. An implantable vascular pressure sensor for sensing blood pressure within a pulmonary artery, the sensor comprising:

a sensor configured to sense blood pressure within the pulmonary artery; and

a fixation element configured to secure the sensor to a wall of the pulmonary artery, the fixation element including: a first wire loop coupled to and extending at least in part proximally from the sensor along a longitudinal axis of the pulmonary artery, the first wire loop configured to expand from a collapsed position to an expanded position within the pulmonary artery, wherein, in the expanded position of the first wire loop, an outer periphery of the first wire loop is configured to contact and assert a radial force against the wall at a first location within the pulmonary artery proximal to the sensor; and

a second wire loop coupled to and extending at least in part distally from the sensor along the longitudinal axis of the pulmonary artery, the second wire loop configured to expand from a collapsed position to an expanded position within the pulmonary artery, wherein, in the expanded position of the second wire loop, an outer periphery of the second wire loop is configured to contact and assert a radial force against the wall at a second location within the pulmonary artery distal to the sensor.

20. An implantable vascular pressure sensor for sensing blood pressure within a pulmonary artery, the sensor comprising:

a sensor configured to sense blood pressure within the pulmonary artery; and

a fixation element configured to secure the sensor to a wall of the pulmonary artery, the fixation element including: a first anchoring member coupled to the sensor, the first anchoring member comprising a single wire loop configured to expand from a collapsed position to an expanded position within the pulmonary artery, wherein, in the expanded position, an outer periphery of the first anchoring member is configured to contact and assert a radial force against the wall at a first location within the pulmonary artery; and

a second anchoring member coupled to the sensor, the second anchoring member comprising a single wire loop configured to expand from a collapsed position to an expanded position within the pulmonary artery, wherein, in the expanded position, an outer periphery of the second anchoring member is configured to contact and assert a radial force against the wall at a second location within the pulmonary artery;

wherein, when the first and second anchoring members are in the expanded position, the sensor is located radially inward and spaced apart from the wall of the pulmonary artery.

* * * * *

专利名称(译)	用于将传感器固定在内腔中的装置		
公开(公告)号	US20090270742A1	公开(公告)日	2009-10-29
申请号	US12/496904	申请日	2009-07-02
[标]申请(专利权)人(译)	REMON医疗TECH		
申请(专利权)人(译)	REMON MEDICAL TECHNOLOGIES LTD.		
当前申请(专利权)人(译)	REMON MEDICAL TECHNOLOGIES LTD		
[标]发明人	WOLINSKY LONE BEN YOSEPH ALON PENNER ABRAHAM		
发明人	WOLINSKY, LONE BEN-YOSEPH, ALON PENNER, ABRAHAM		
IPC分类号	A61B5/02 A61B5/00 A61B5/0215 A61F2/02 A61F2/82 A61F2/86		
CPC分类号	A61B5/0031 A61B5/0215 A61B5/145 A61B5/6882 A61F2230/0091 A61F2/82 A61F2/86 A61F2250/0002 A61B5/6886		
优先权	60/536580 2004-01-13 US		
其他公开文献	US9149193		
外部链接	Espacenet USPTO		

摘要(译)

用于将至少一个传感器定位在体腔中的装置，该装置包括固定元件，传感器和将传感器连接到固定元件的连接元件，该连接元件至少部分地延伸到管腔中，使得传感器是从腔的壁径向向内定位。

