



US007654966B2

(12) **United States Patent**  
**Westinskow et al.**

(10) **Patent No.:** **US 7,654,966 B2**  
(45) **Date of Patent:** **Feb. 2, 2010**

(54) **METHOD AND APPARATUS FOR MONITORING DYNAMIC CARDIOVASCULAR FUNCTION USING N-DIMENSIONAL REPRESENTATIVES OF CRITICAL FUNCTIONS**

(75) Inventors: **Dwayne Westinskow**, Salt Lake City, UT (US); **James Agutter**, Salt Lake City, UT (US); **Noah Syroid**, Salt Lake City, UT (US); **David Strayer**, Salt Lake City, UT (US); **Robert Albert**, Salt Lake City, UT (US); **S. Blake Wachter**, Huntsville, UT (US); **Frank Drews**, Salt Lake City, UT (US)

(73) Assignee: **University of Utah Research Foundation**, Salt Lake City, UT (US)

(\* ) Notice: Subject to any disclaimer, the term of this patent is extended or adjusted under 35 U.S.C. 154(b) by 1393 days.

(21) Appl. No.: **10/269,423**

(22) Filed: **Oct. 11, 2002**

(65) **Prior Publication Data**

US 2003/0227472 A1 Dec. 11, 2003

**Related U.S. Application Data**

(63) Continuation-in-part of application No. 09/457,068, filed on Dec. 7, 1999, now abandoned.

(60) Provisional application No. 60/328,880, filed on Oct. 12, 2001.

(51) **Int. Cl.**  
**A61B 5/08** (2006.01)

(52) **U.S. Cl.** ..... **600/532; 600/538; 600/529**

(58) **Field of Classification Search** ..... **600/485, 600/529-543; 434/262-275**

See application file for complete search history.

(56) **References Cited**

U.S. PATENT DOCUMENTS

4,598,706 A *	7/1986	Darowski et al.	128/205.24
4,752,893 A	6/1988	Gutttag et al.	
4,772,882 A	9/1988	Mical	
4,813,013 A	3/1989	Dunn	
4,823,283 A	4/1989	Diehm et al.	
4,915,757 A	4/1990	Rando	
4,939,757 A *	7/1990	Nambu	378/8
4,984,158 A *	1/1991	Hillsman	128/200.14
5,021,976 A	6/1991	Wexelblat et al.	
5,121,469 A	6/1992	Richards et al.	
5,129,401 A *	7/1992	Corenman et al.	600/529
5,262,944 A	11/1993	Weisner et al.	
5,317,321 A	5/1994	Sass	
5,333,106 A *	7/1994	Lanpher et al.	600/538
5,491,779 A	2/1996	Bezjian	
5,515,301 A	5/1996	Corby, Jr. et al.	

(Continued)

*Primary Examiner*—Charles A Marmor, II  
*Assistant Examiner*—Navin Natnithithadha  
(74) *Attorney, Agent, or Firm*—Thorpe North & Western LLP

(57) **ABSTRACT**

A method, system, apparatus and device for the monitoring, diagnosis and evaluation of the state of a dynamic pulmonary system is disclosed. This method and system provides the processing means for receiving sensed and/or simulated data, converting such data into a displayable object format and displaying such objects in a manner such that the interrelationships between the respective variables can be correlated and identified by a user. This invention provides for the rapid cognitive grasp of the overall state of a pulmonary critical function with respect to a dynamic system.

**16 Claims, 33 Drawing Sheets**

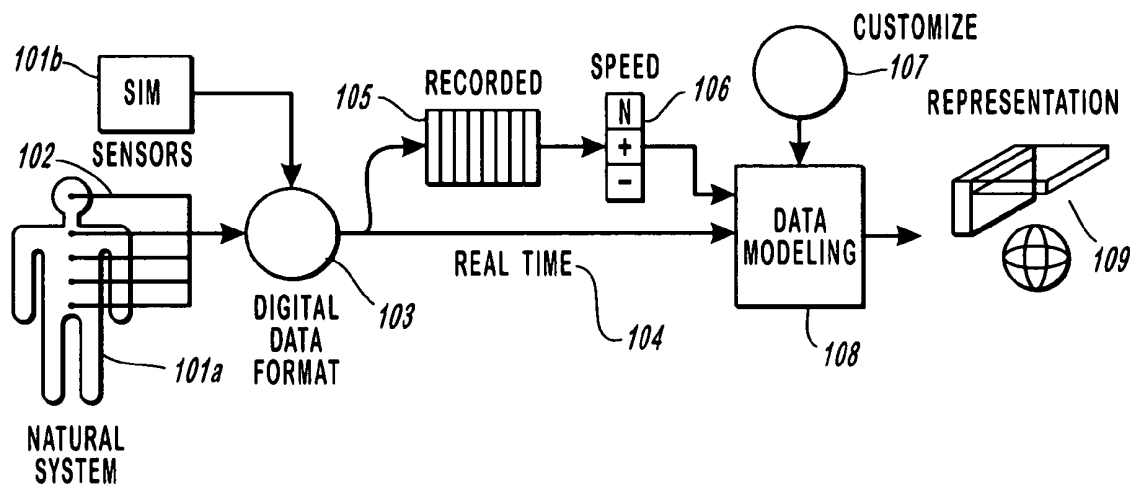

U.S. PATENT DOCUMENTS					
5,588,104 A	12/1996	Lainier et al.	6,158,432 A *	12/2000	Biondi et al. .... 128/204.21
5,592,195 A	1/1997	Misono et al.	6,201,542 B1	3/2001	Arai et al.
5,596,694 A	1/1997	Capps	6,222,547 B1	4/2001	Schwuttke et al.
5,731,819 A	3/1998	Gagne et al.	6,417,854 B1	7/2002	Isowaki et al.
5,751,931 A	5/1998	Cox et al.	6,463,930 B2 *	10/2002	Biondi et al. .... 128/204.21
5,768,552 A	6/1998	Jacoby	6,575,918 B2 *	6/2003	Kline ..... 600/532
5,774,878 A	6/1998	Marshall	6,584,973 B1 *	7/2003	Biondi et al. .... 128/204.21
5,796,398 A	8/1998	Zimmer	6,612,995 B2 *	9/2003	Leonhardt et al. .... 600/532
5,812,134 A	9/1998	Pooser et al.	6,745,764 B2 *	6/2004	Hickle ..... 128/203.12
5,830,150 A	11/1998	Palmer et al.	7,066,892 B2 *	6/2006	Kline ..... 600/532
5,923,330 A	7/1999	Tartlton et al.	7,128,578 B2 *	10/2006	Lampotang et al. .... 434/365
5,931,160 A *	8/1999	Gilmore et al. .... 128/204.21	2003/0060725 A1 *	3/2003	Kline ..... 600/529

\* cited by examiner

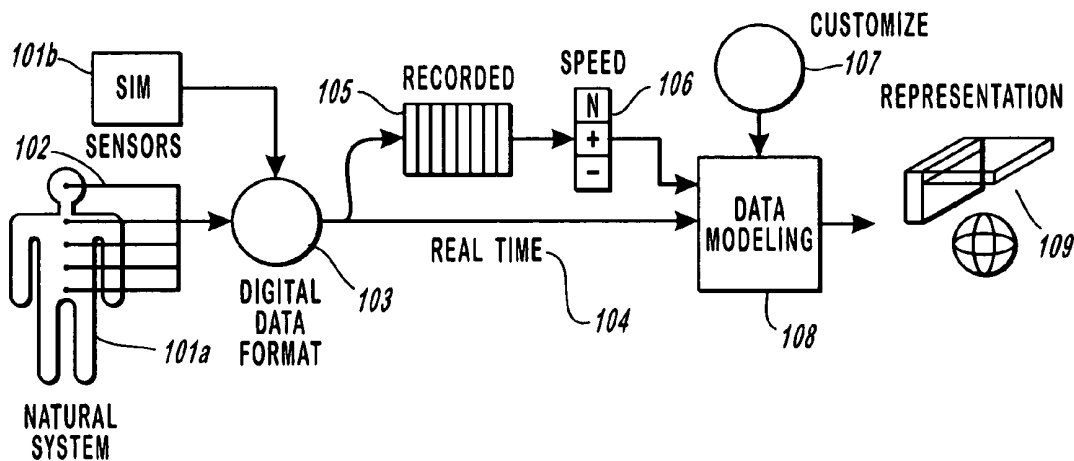

FIGURE 1a

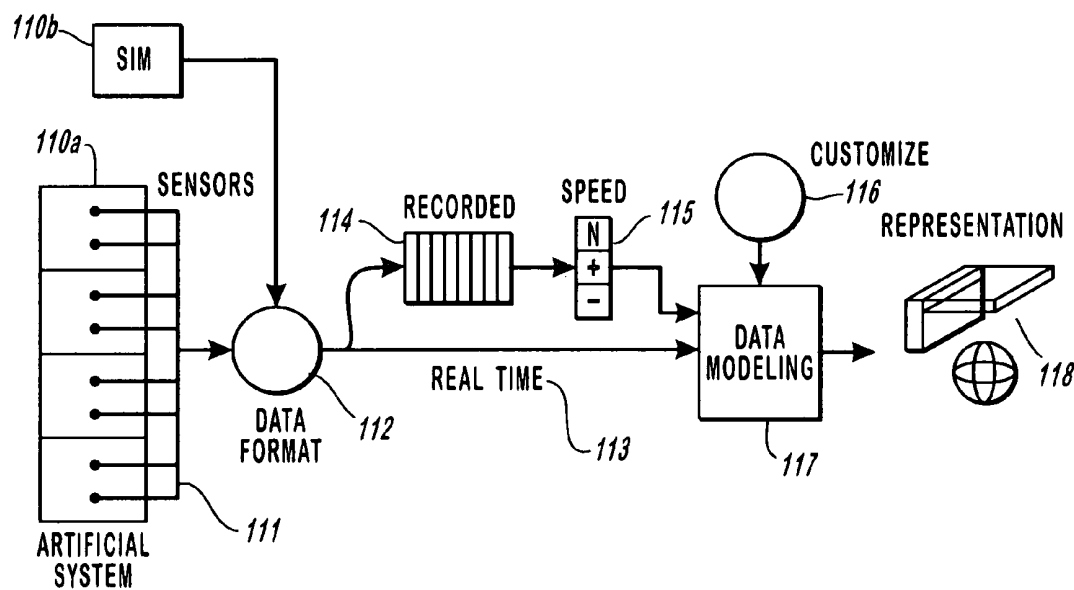

FIGURE 1b

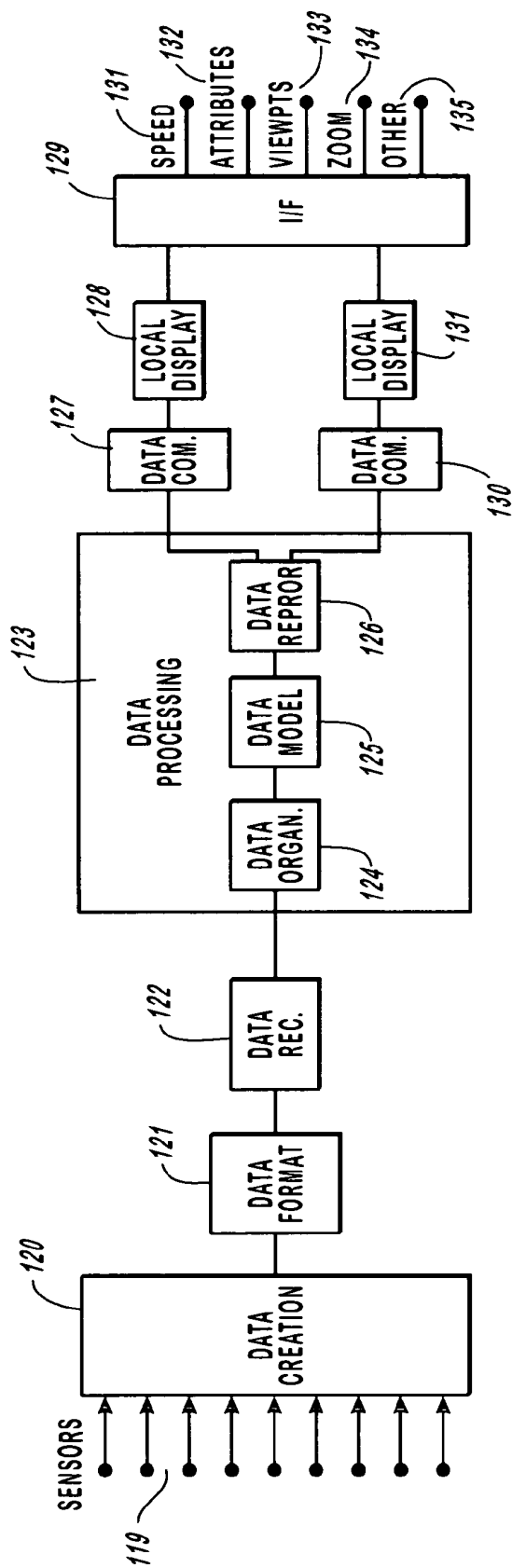

FIGURE 1c

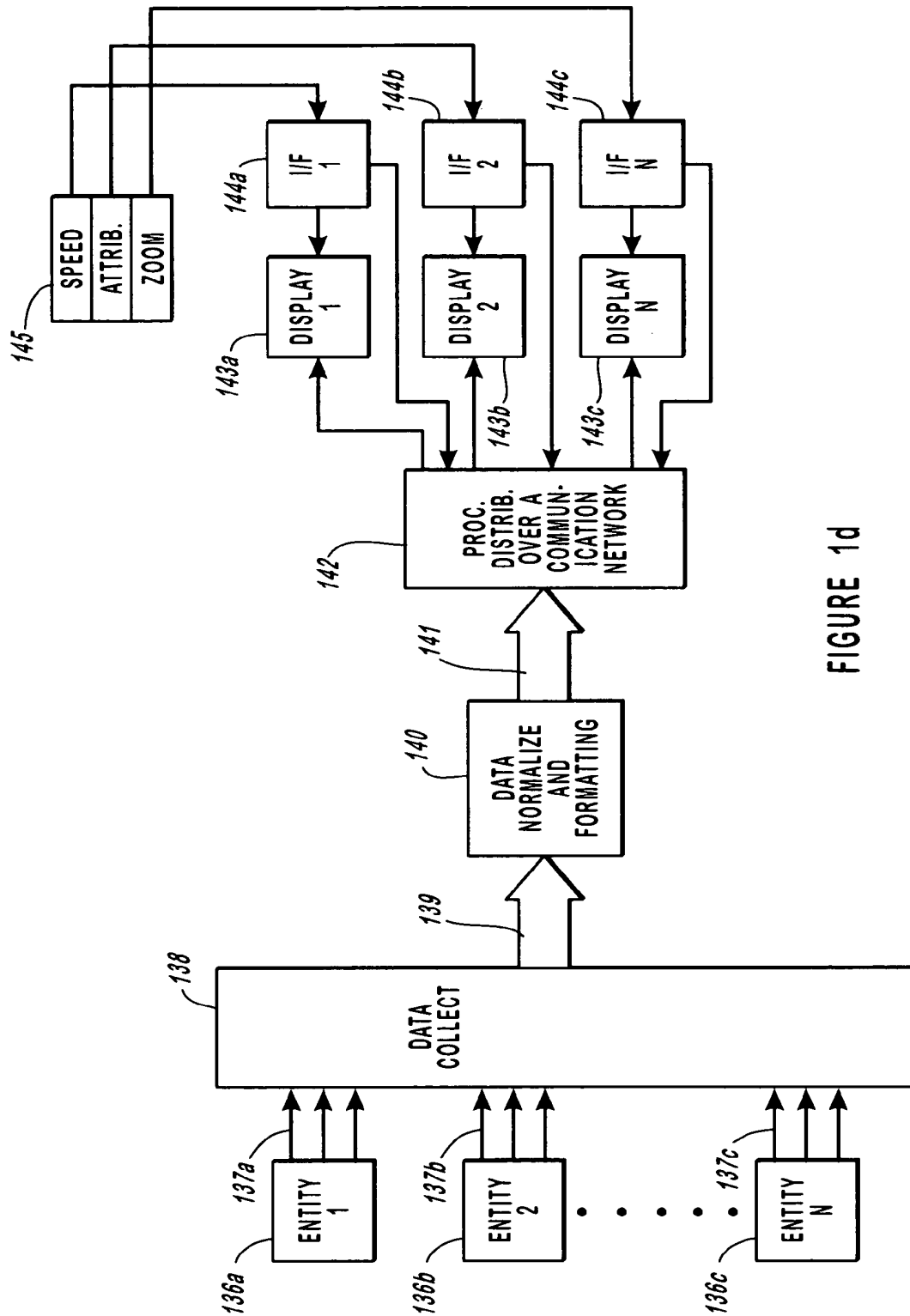

FIGURE 1d

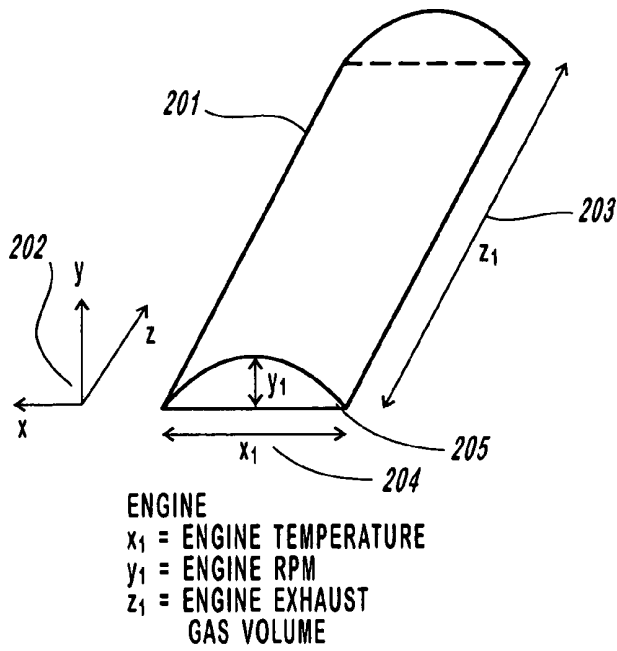

FIGURE 2a

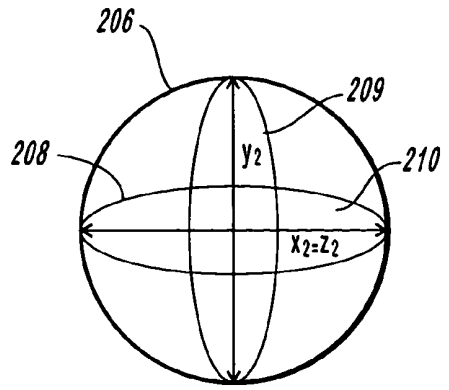

FIGURE 2b

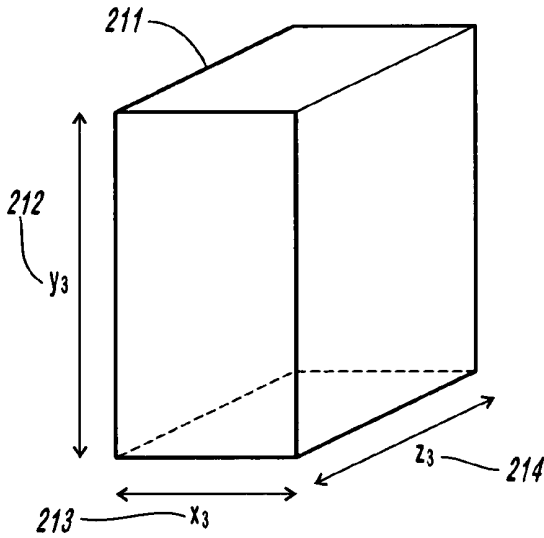

FIGURE 2c

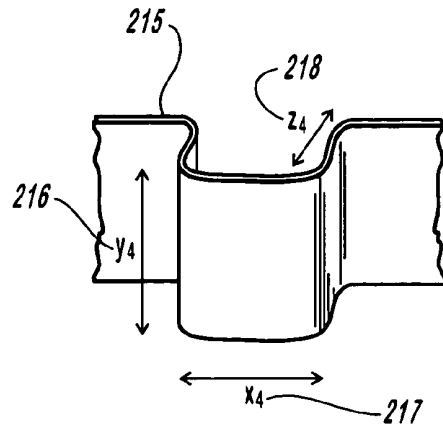

FIGURE 2d

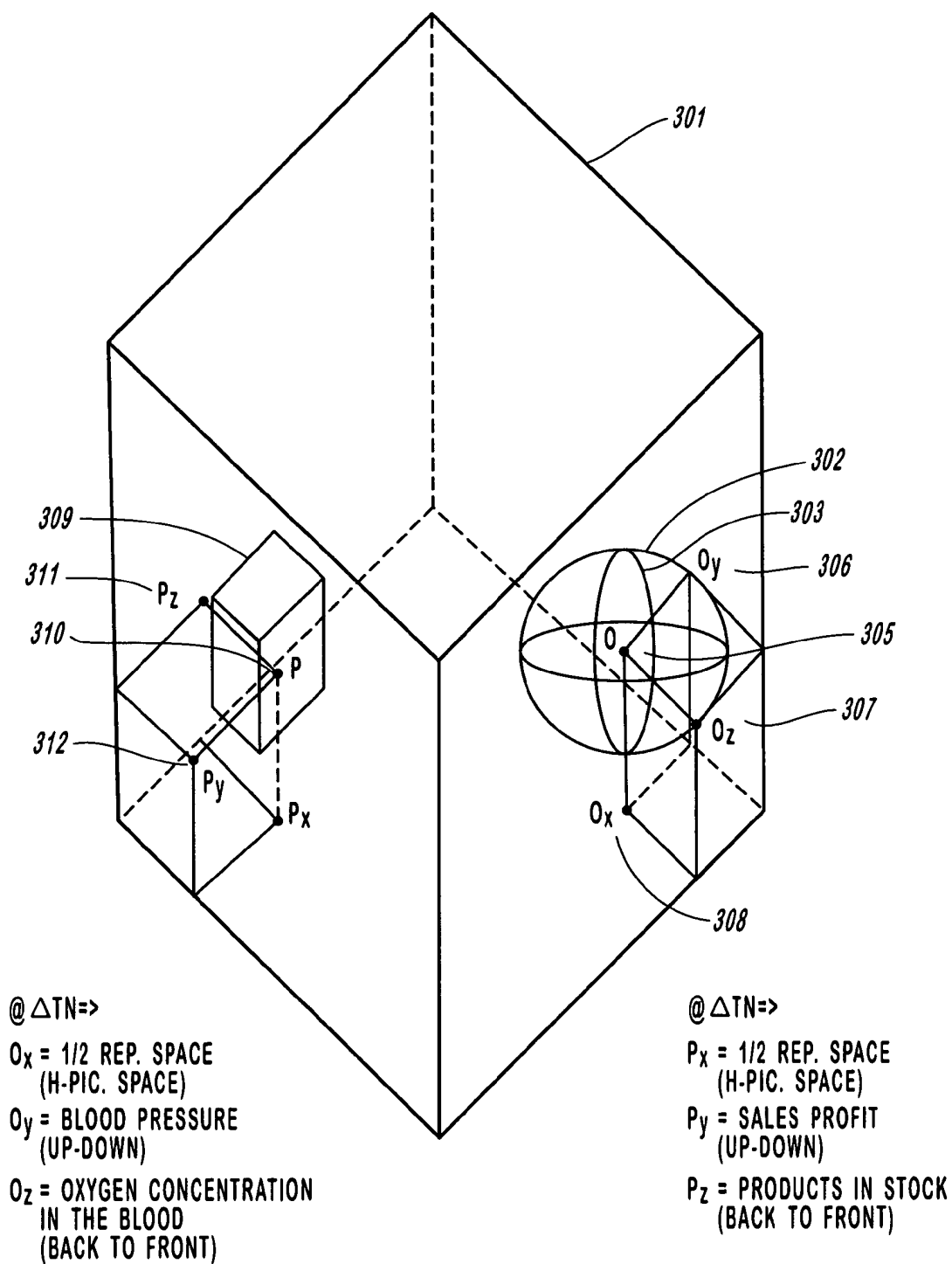

FIGURE 3

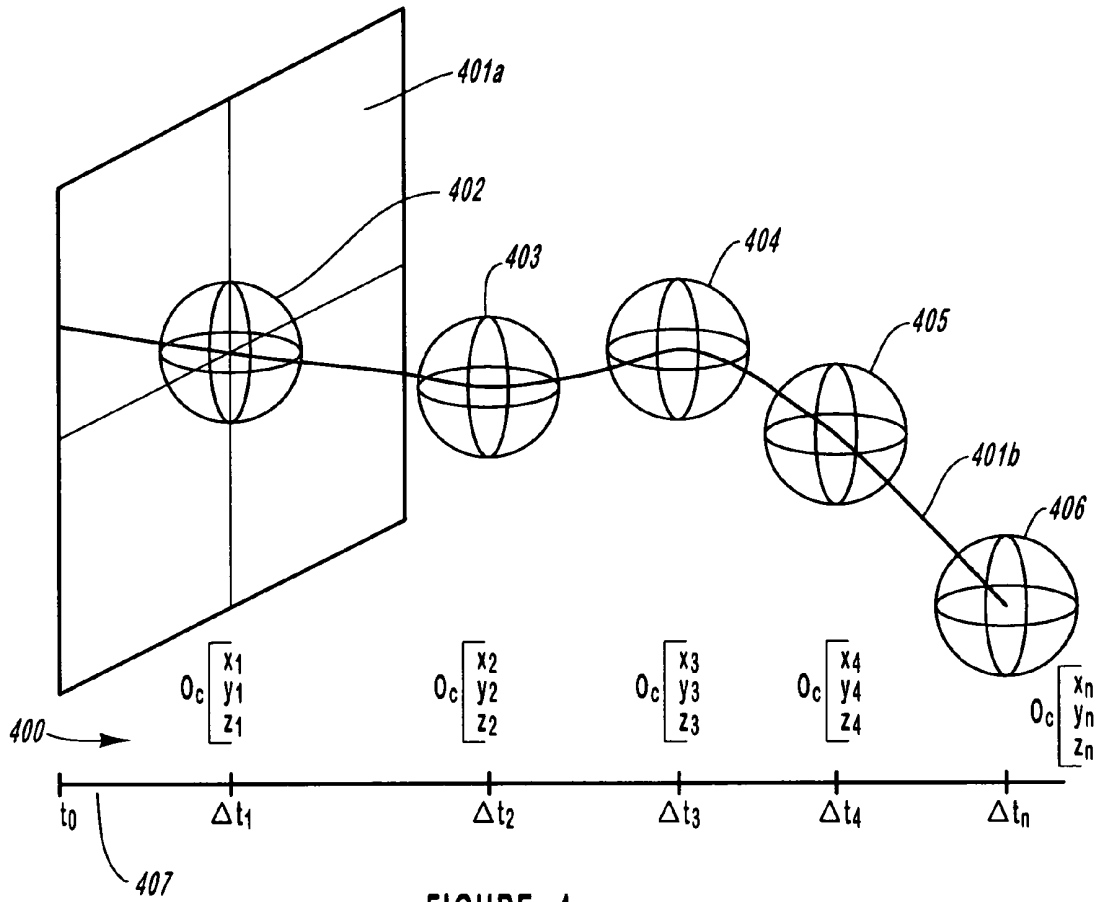

FIGURE 4a

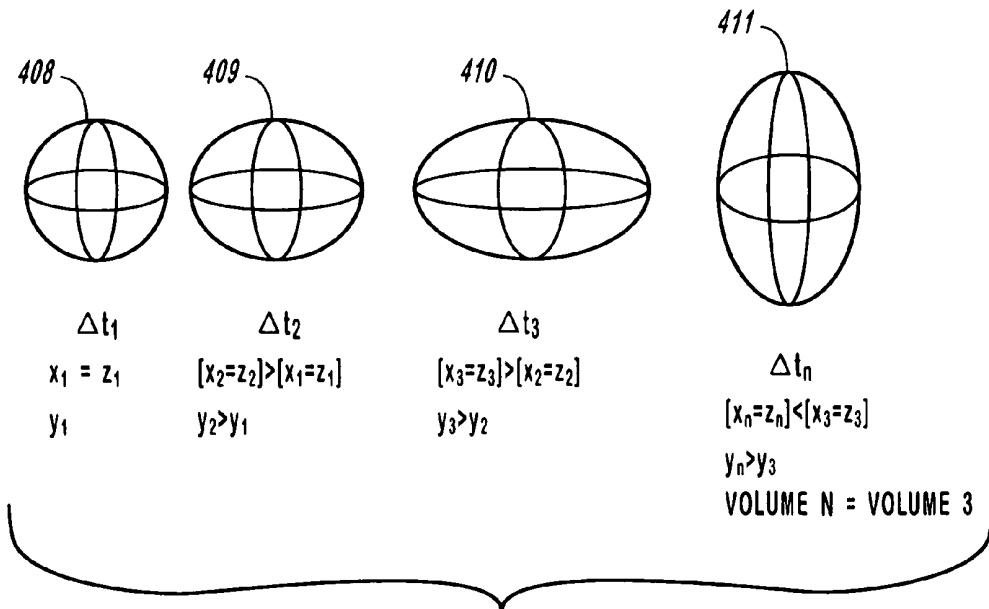

FIGURE 4b

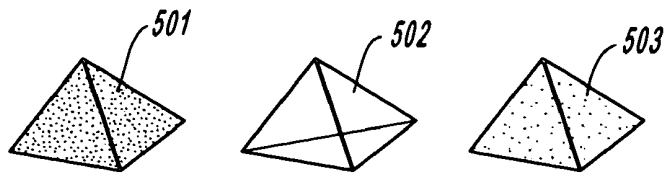

FIGURE 5a

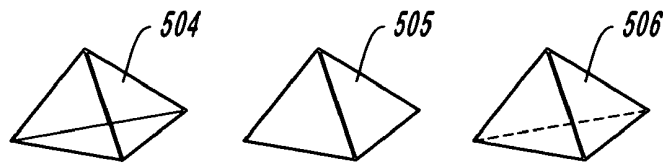

FIGURE 5b

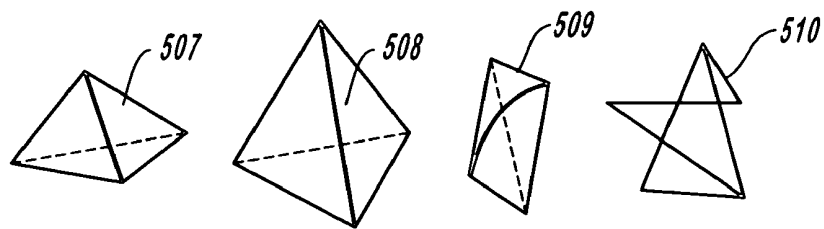

FIGURE 5c

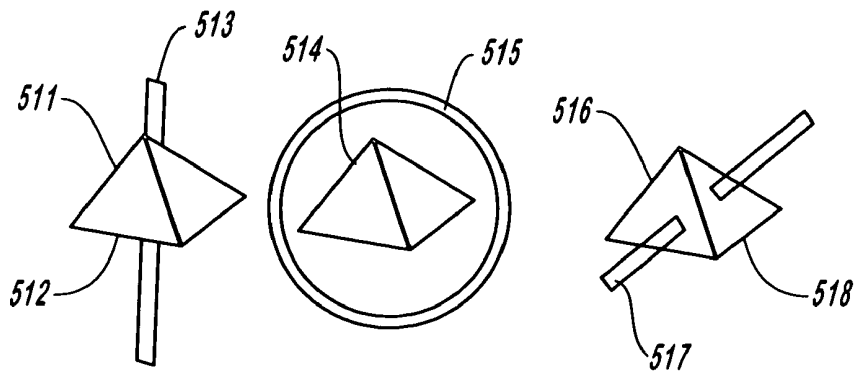

FIGURE 5d

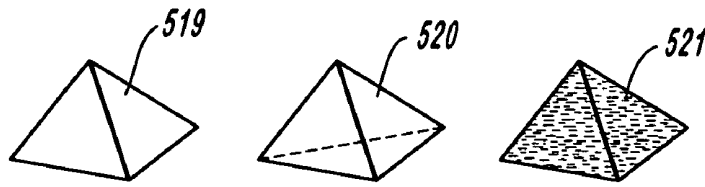

FIGURE 5e

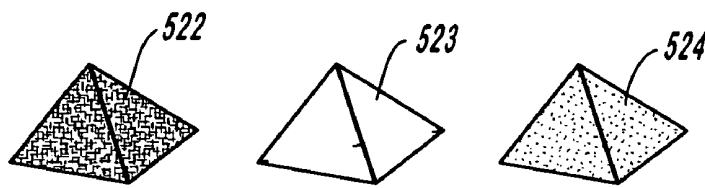

FIGURE 5f

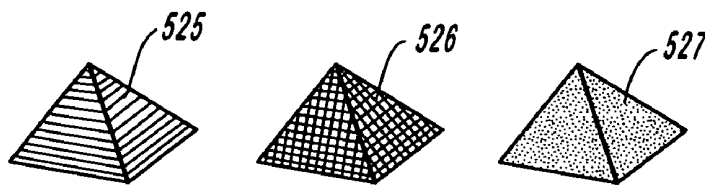

FIGURE 5g

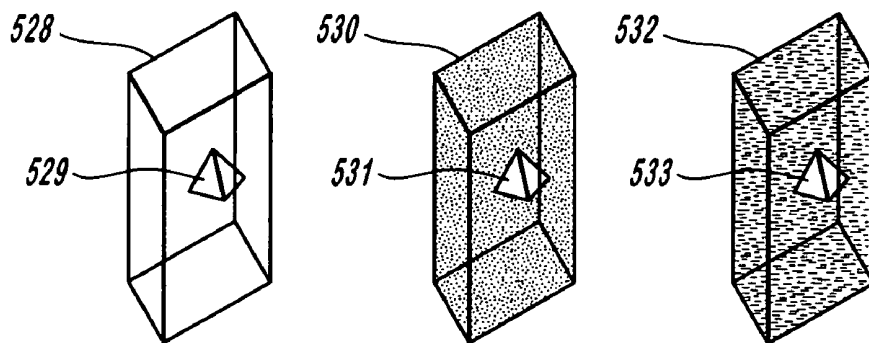

FIGURE 5h

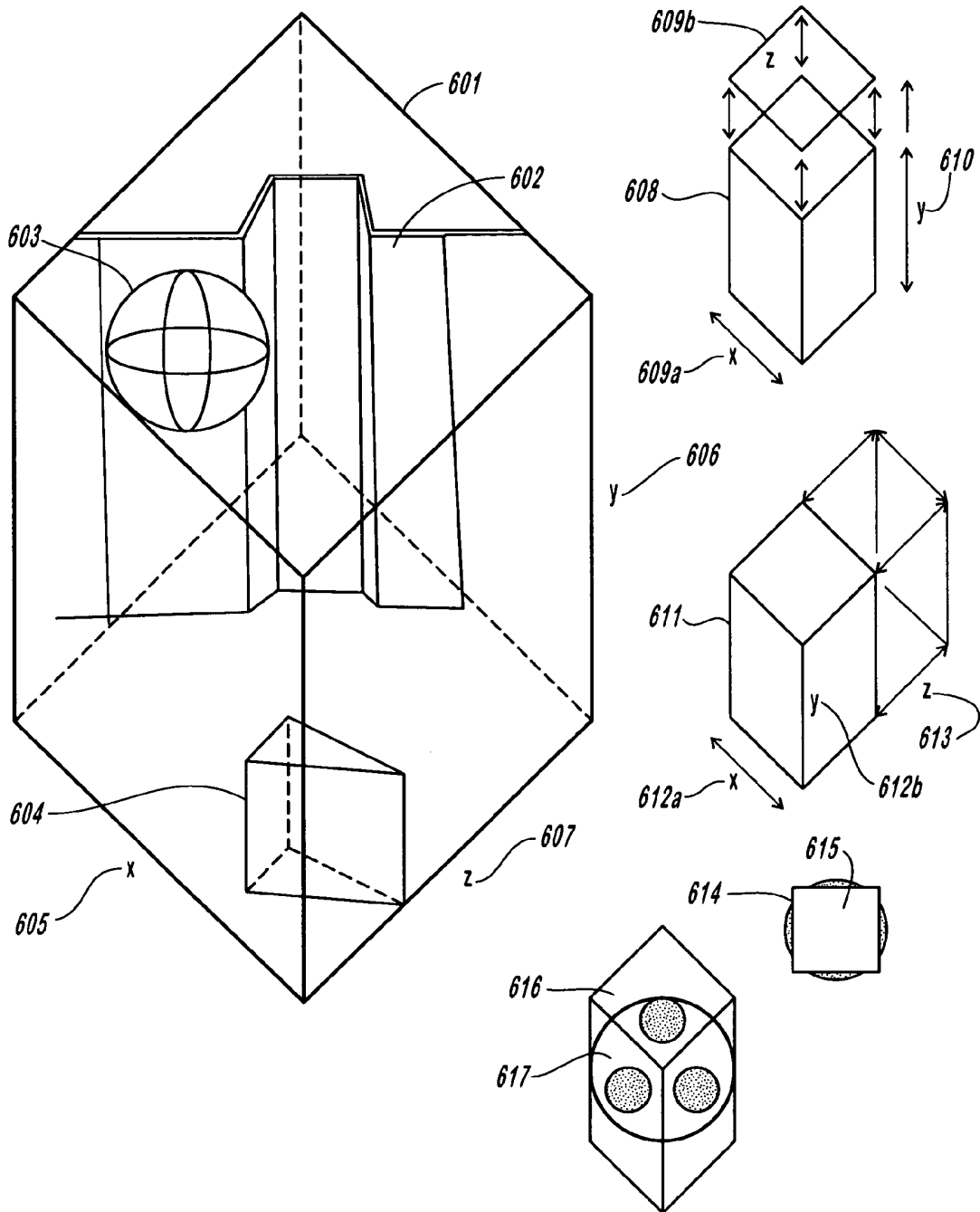

FIGURE 6

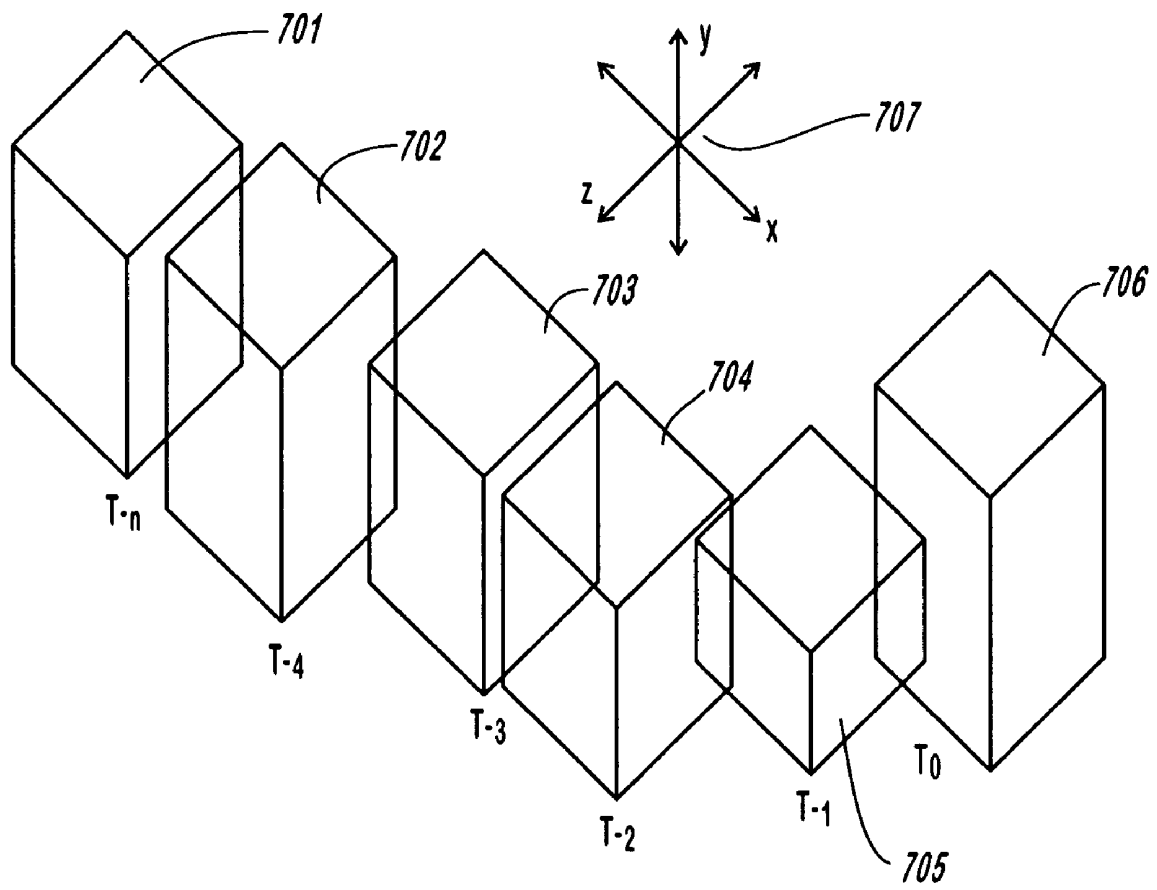

FIGURE 7

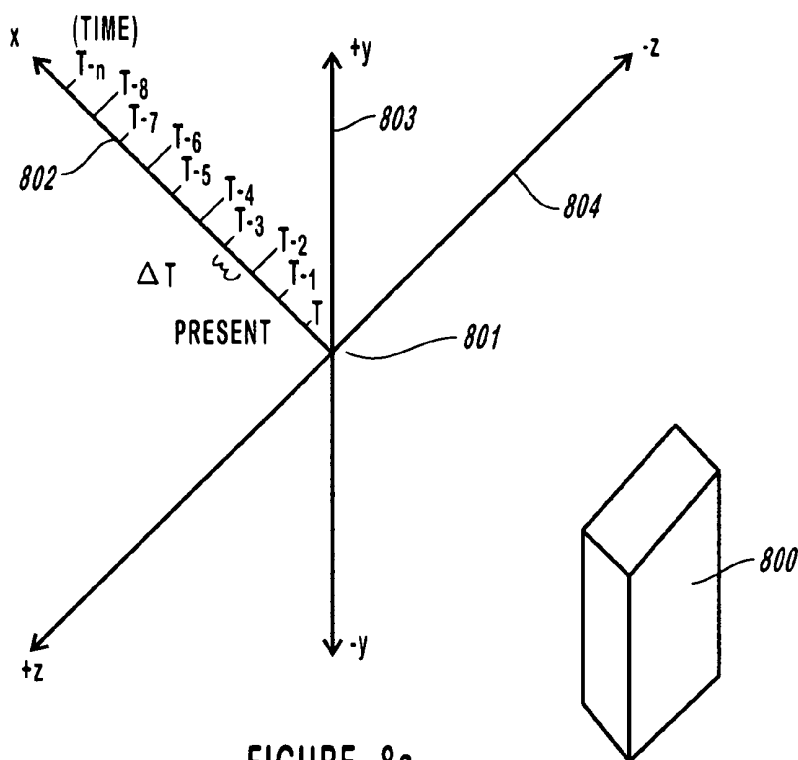

FIGURE 8a

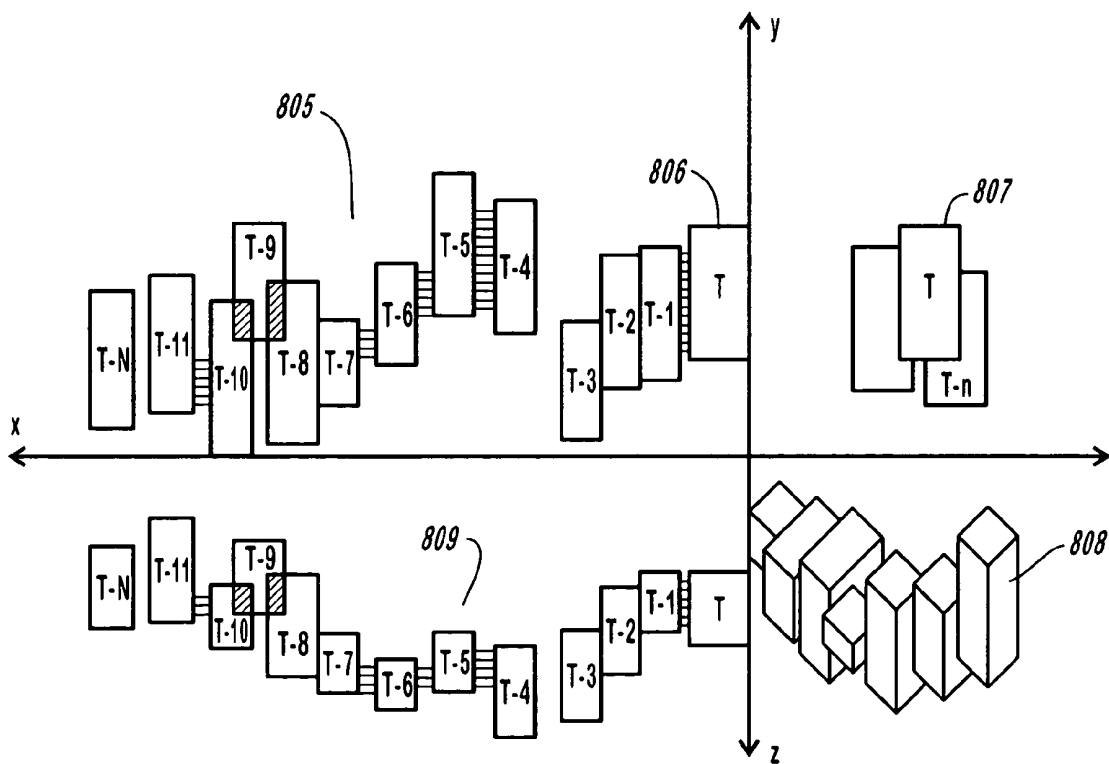

FIGURE 8b

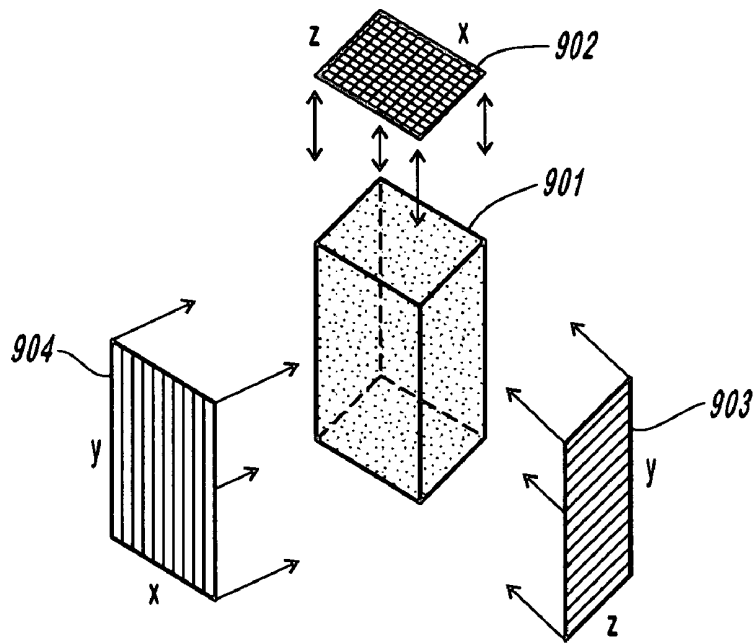

FIGURE 9a

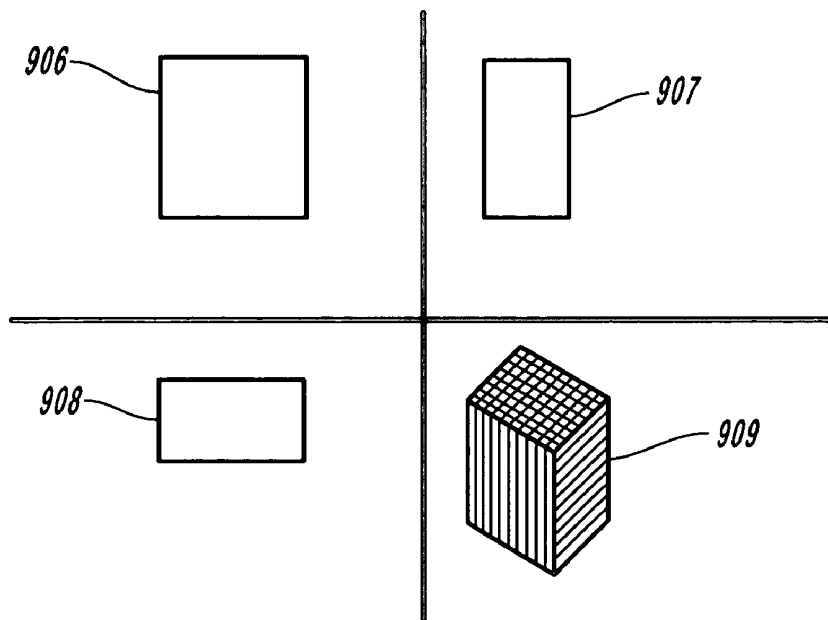

FIGURE 9b

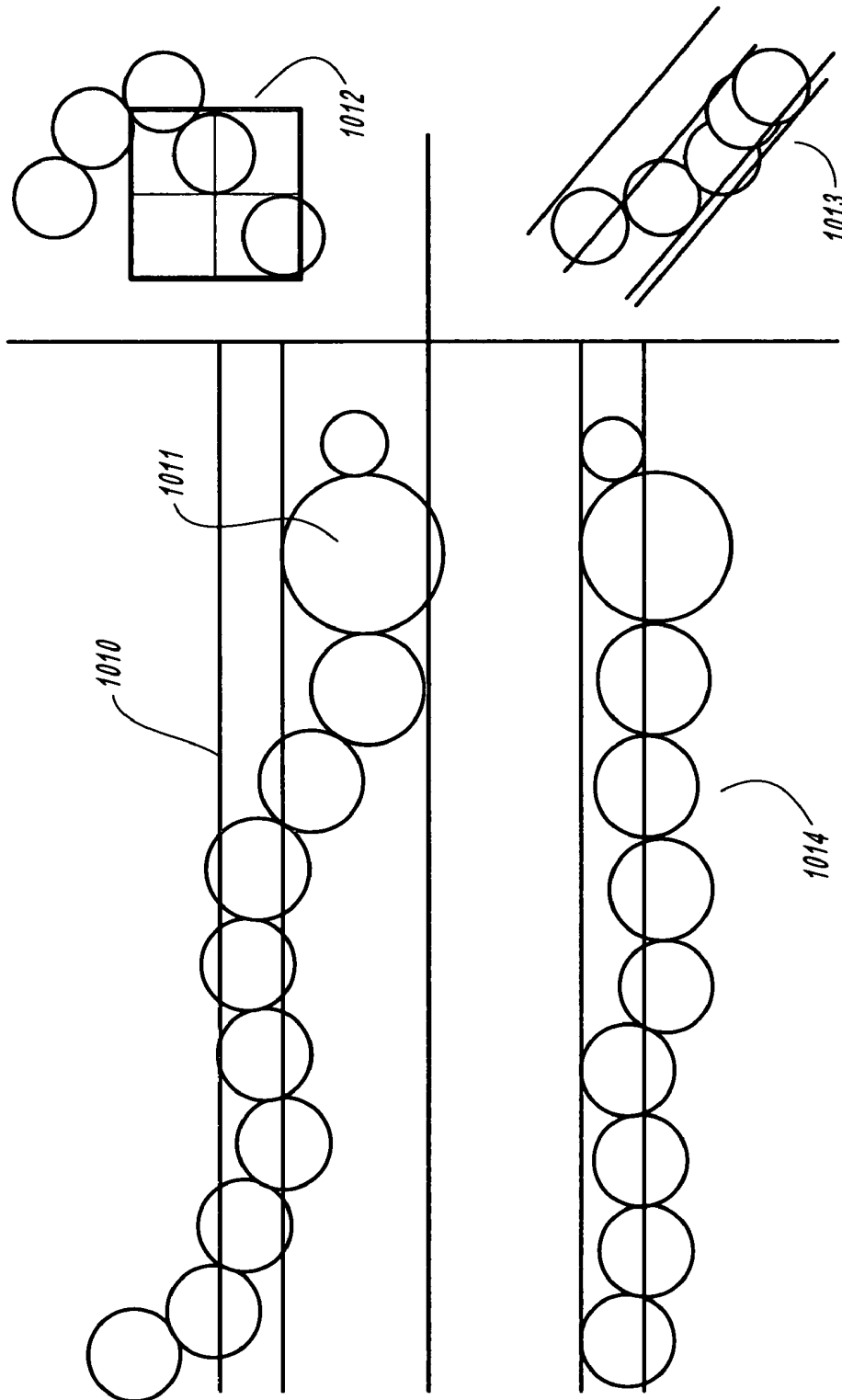

FIGURE 10

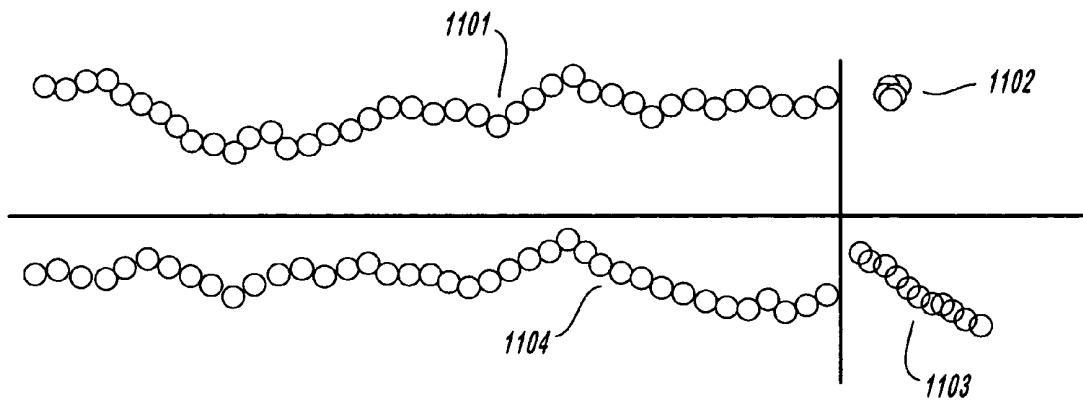

FIGURE 11a

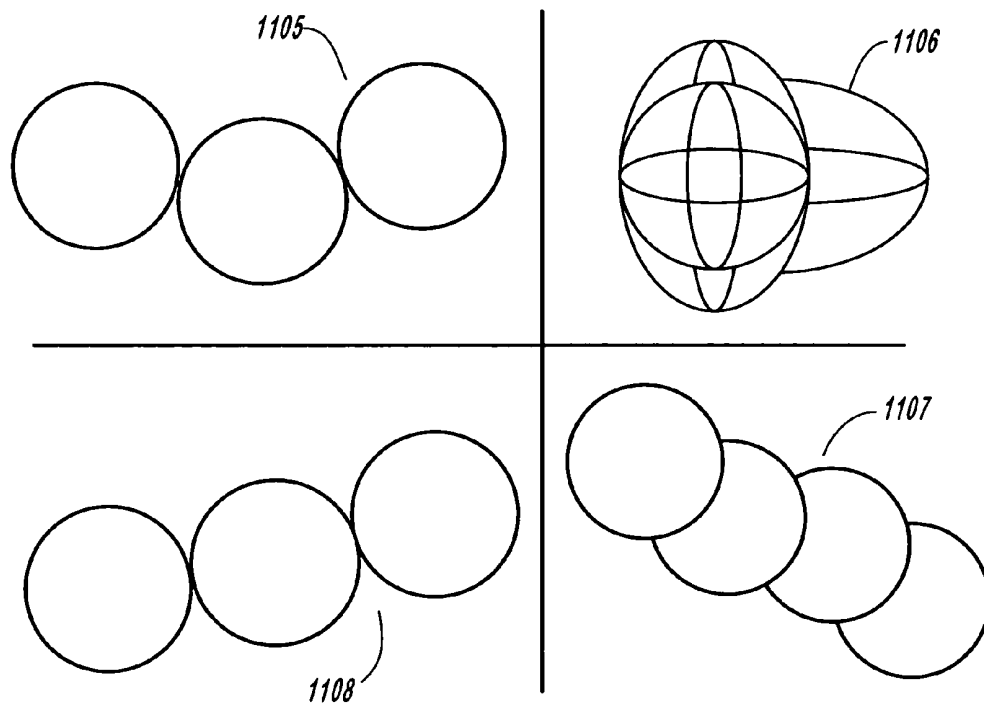

FIGURE 11b

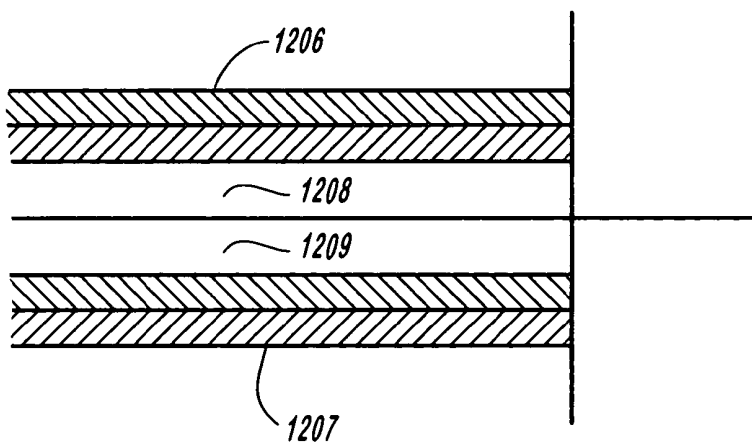
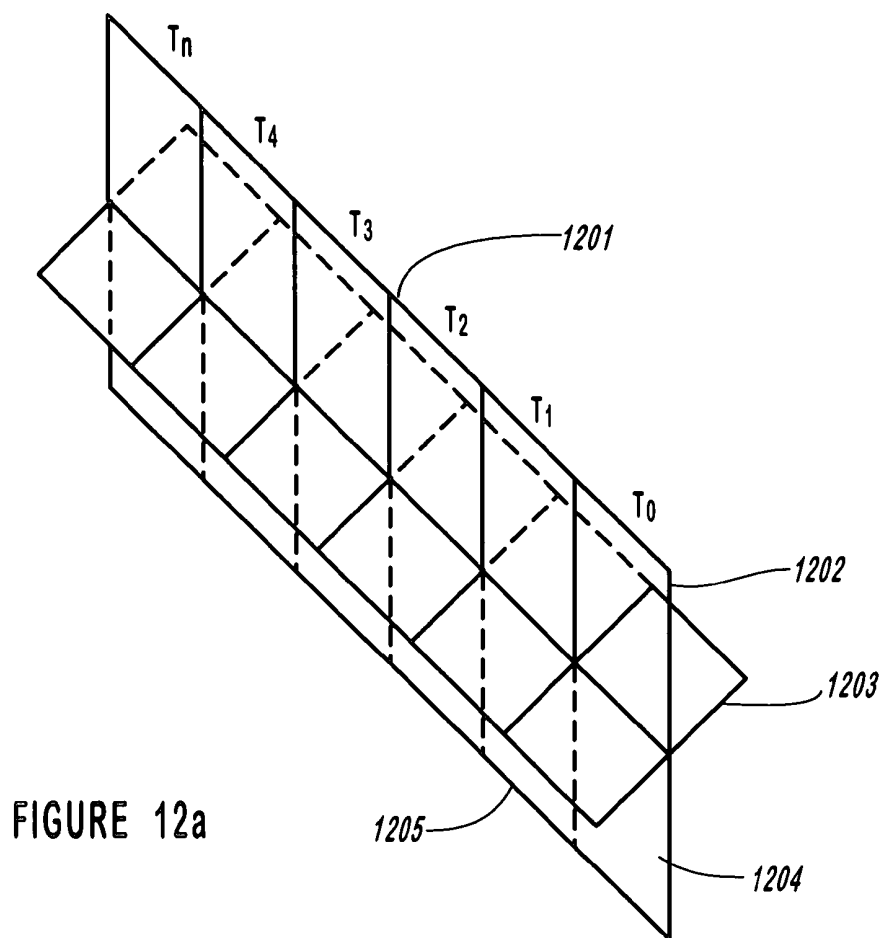
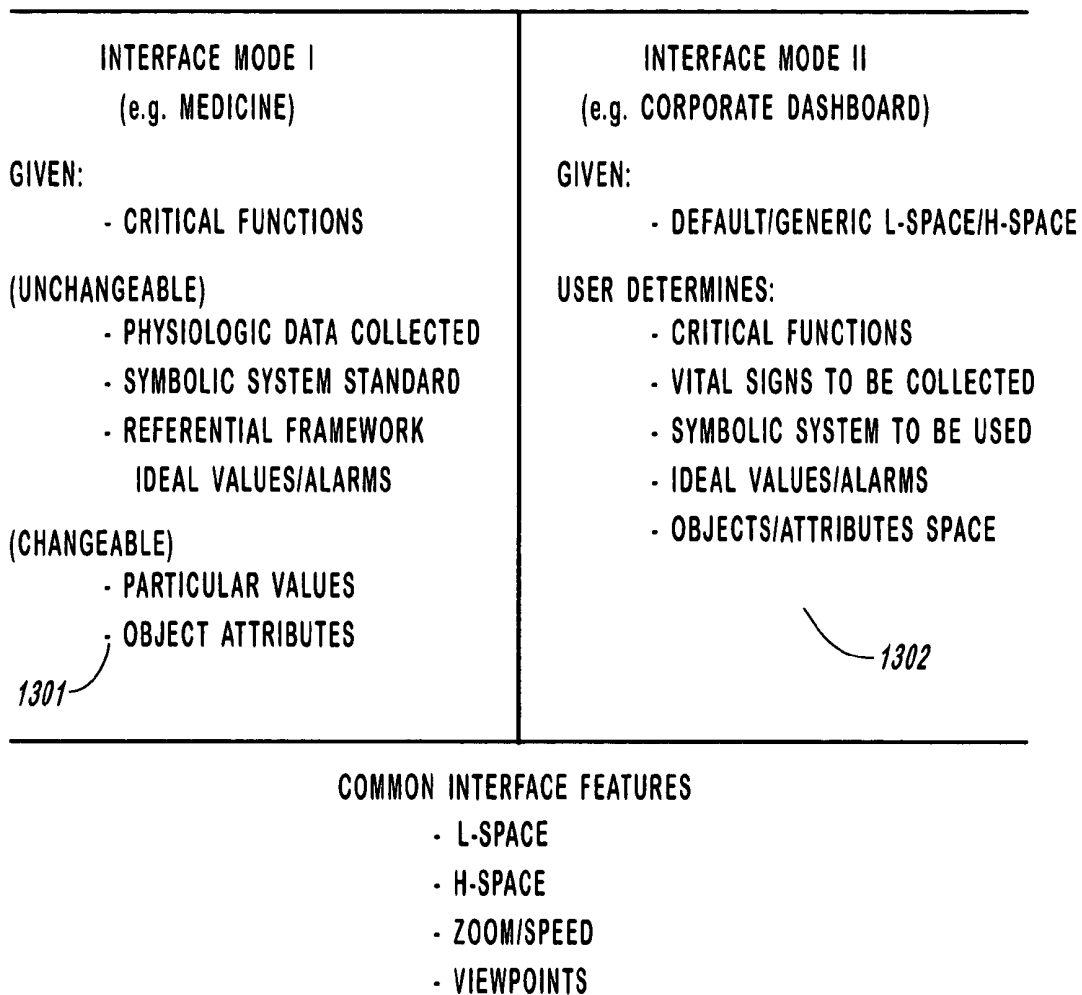

FIGURE 12b



**FIGURE 13**

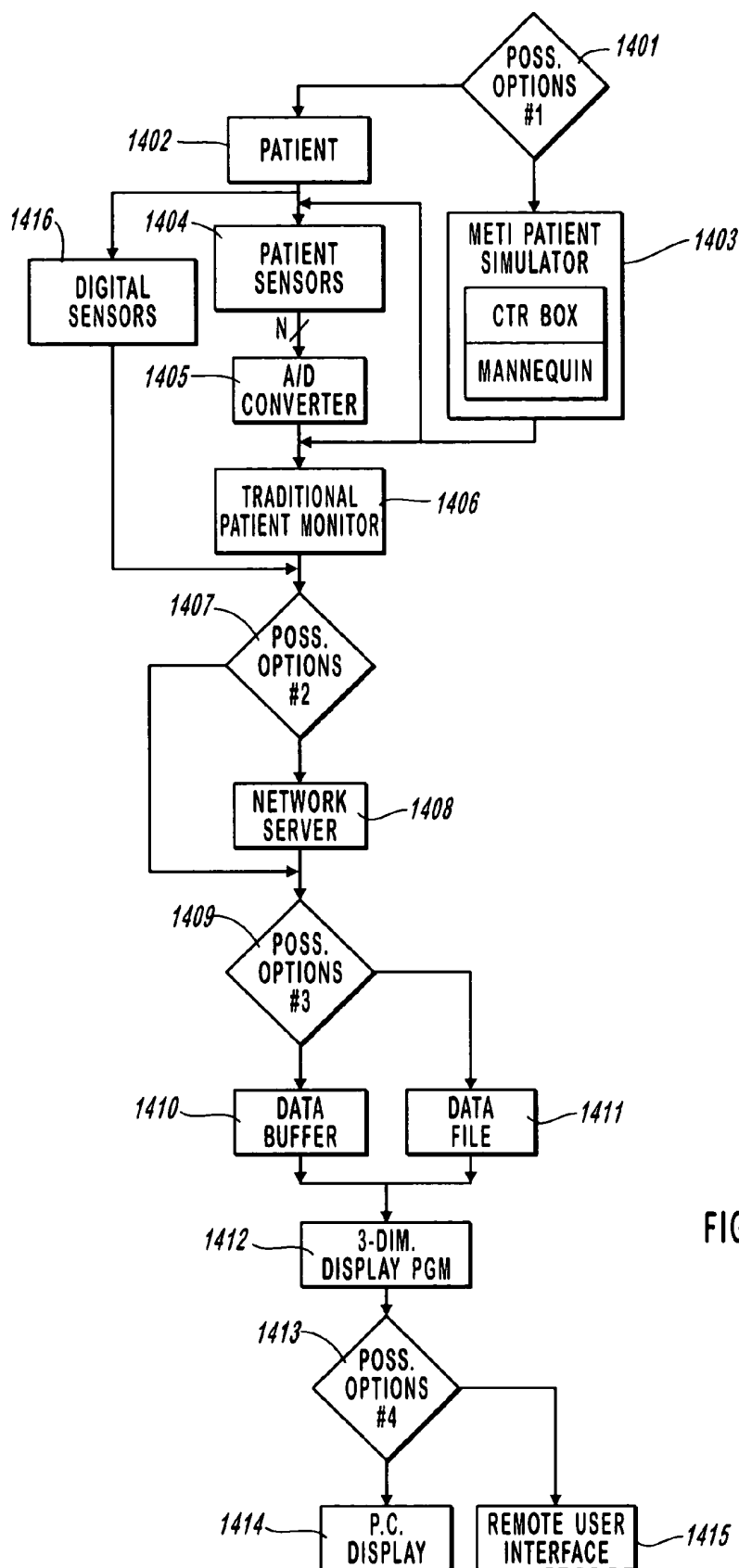

FIGURE 14

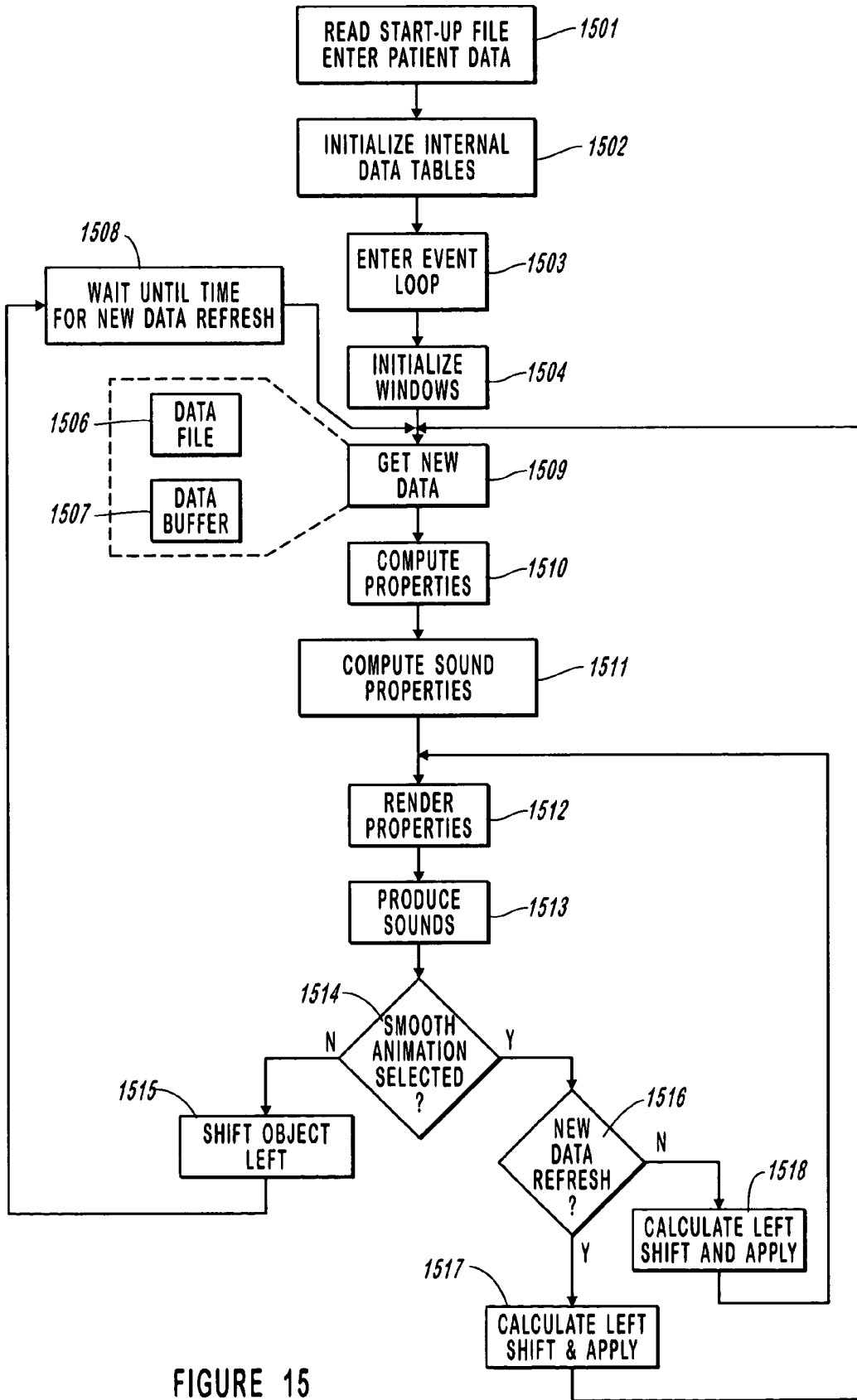

FIGURE 15

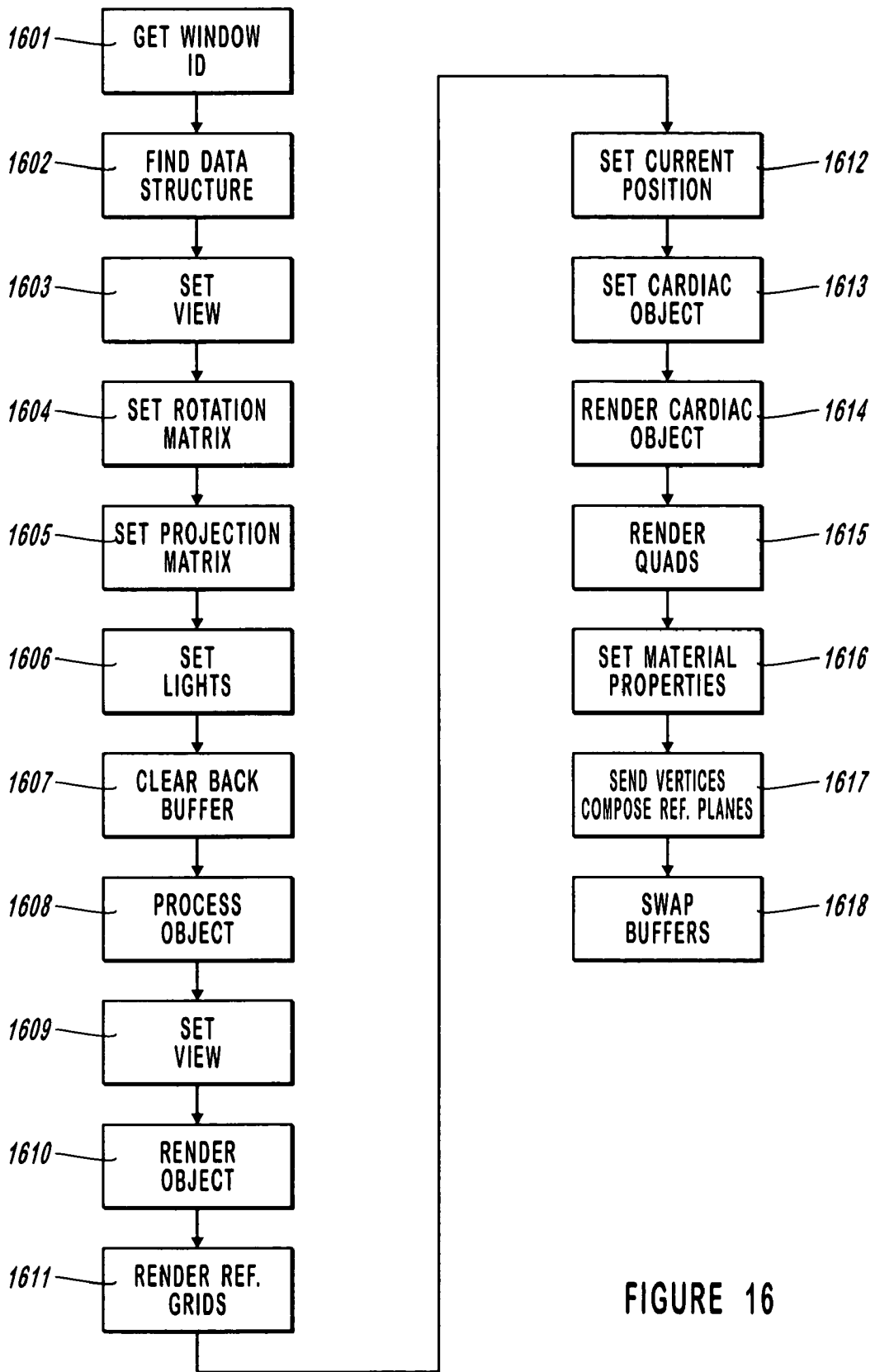

FIGURE 16

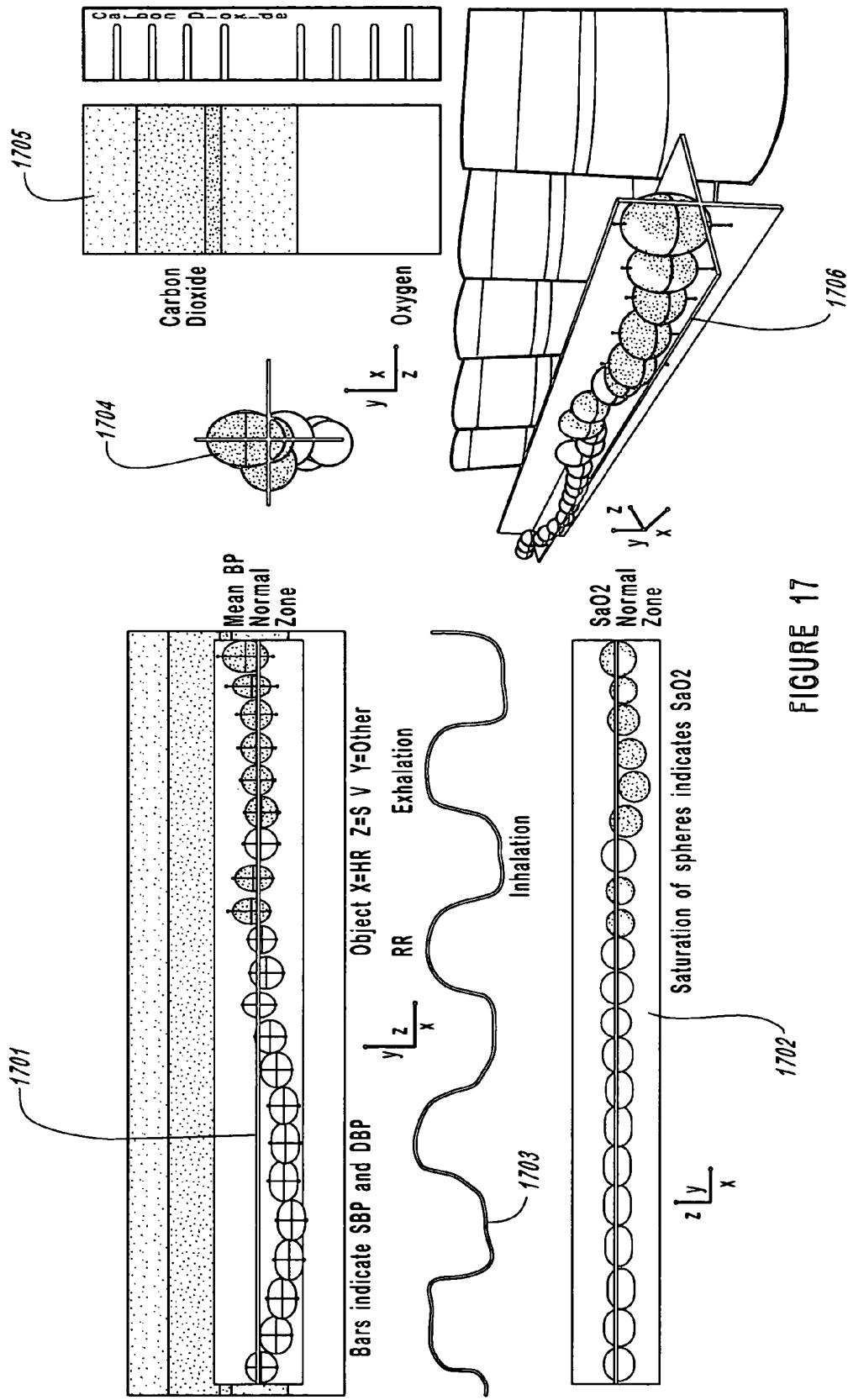

FIGURE 17

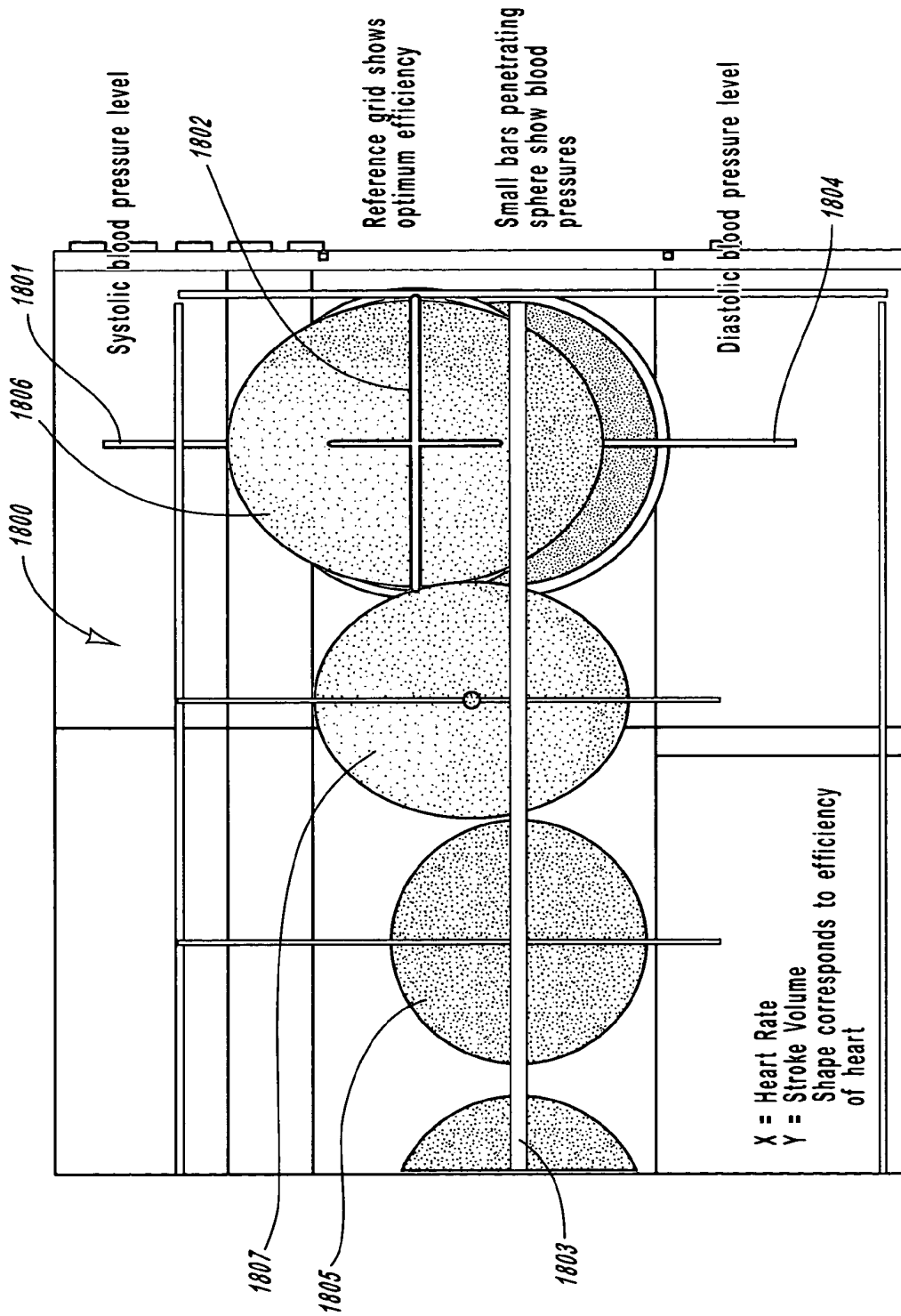

FIGURE 18

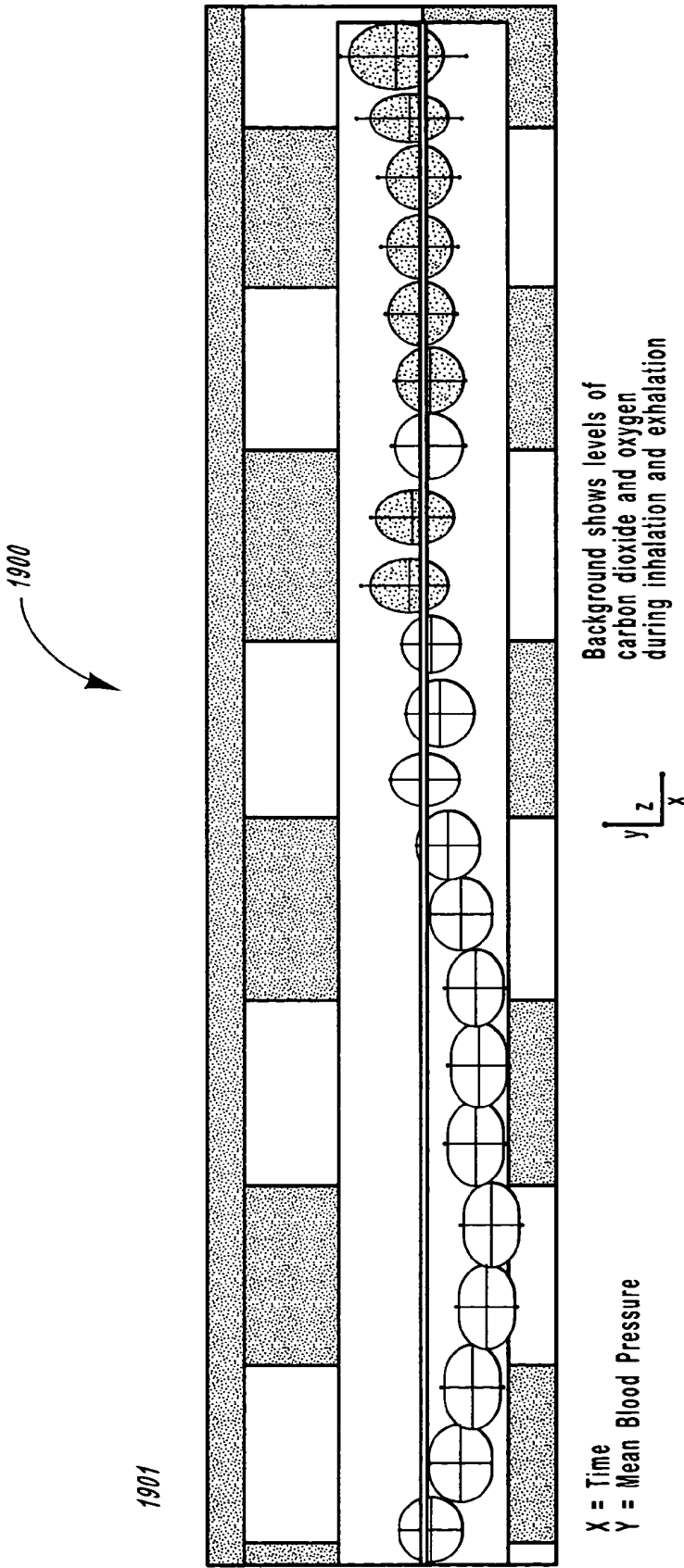

FIGURE 19

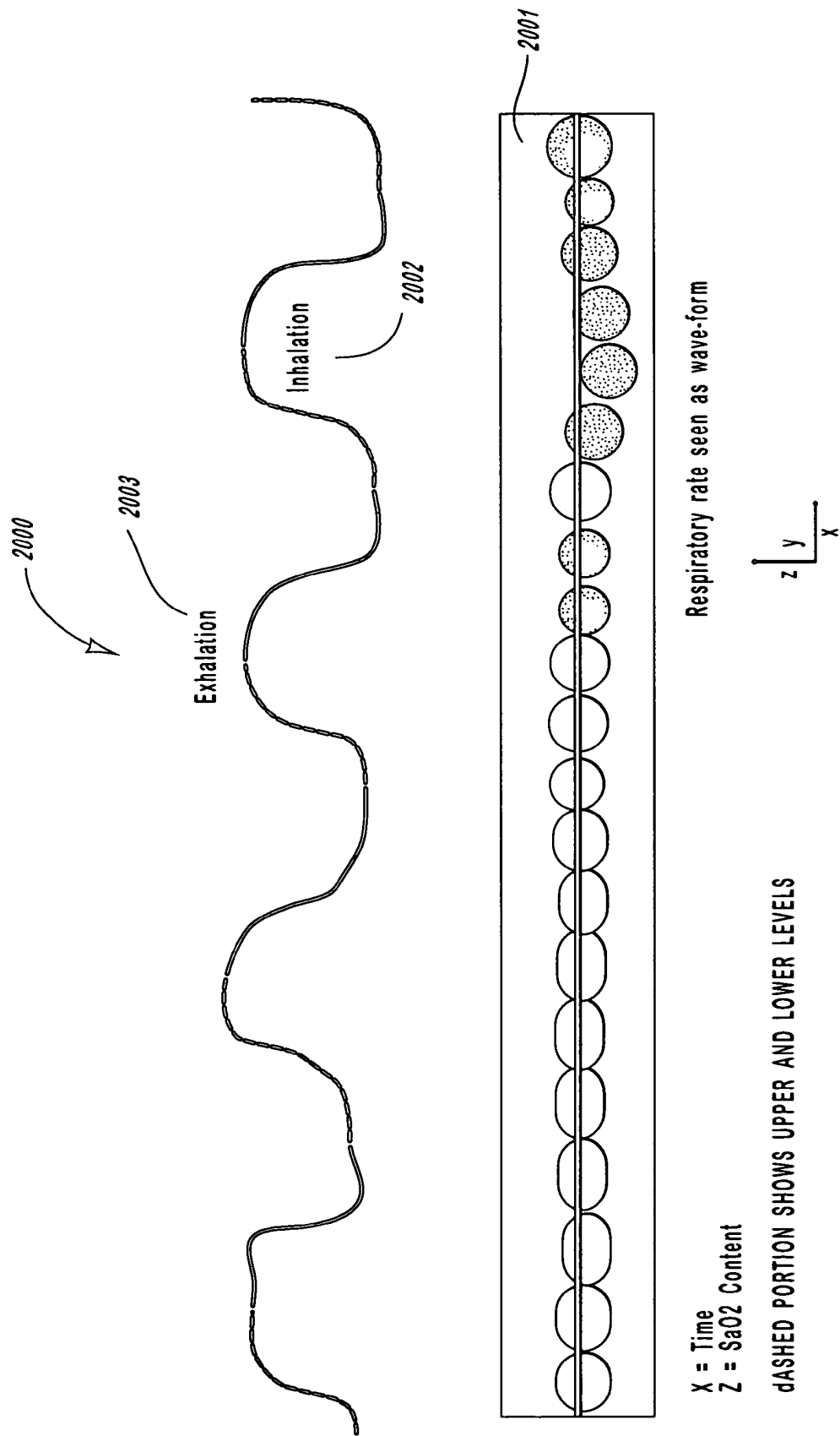

FIGURE 20

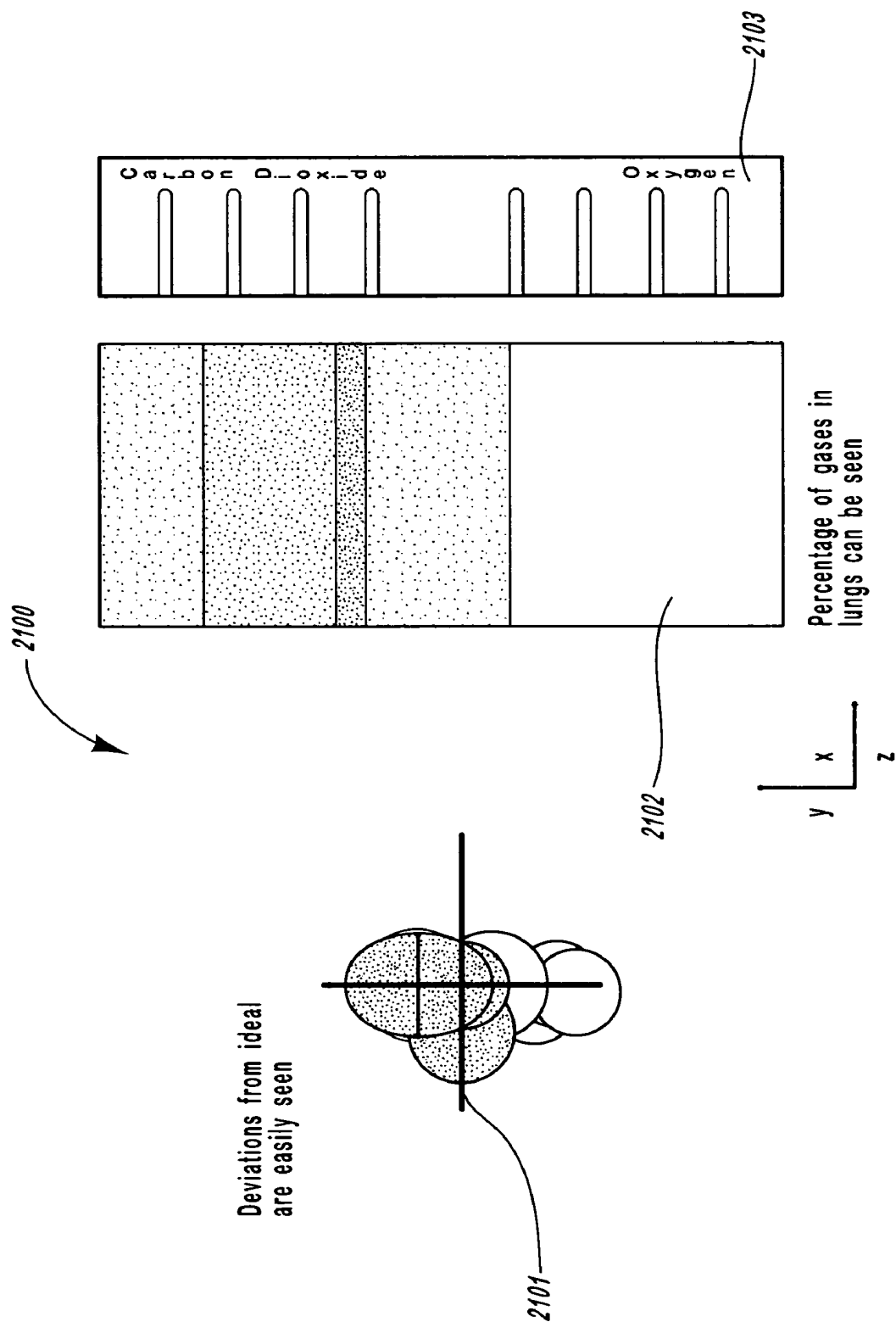

FIGURE 21

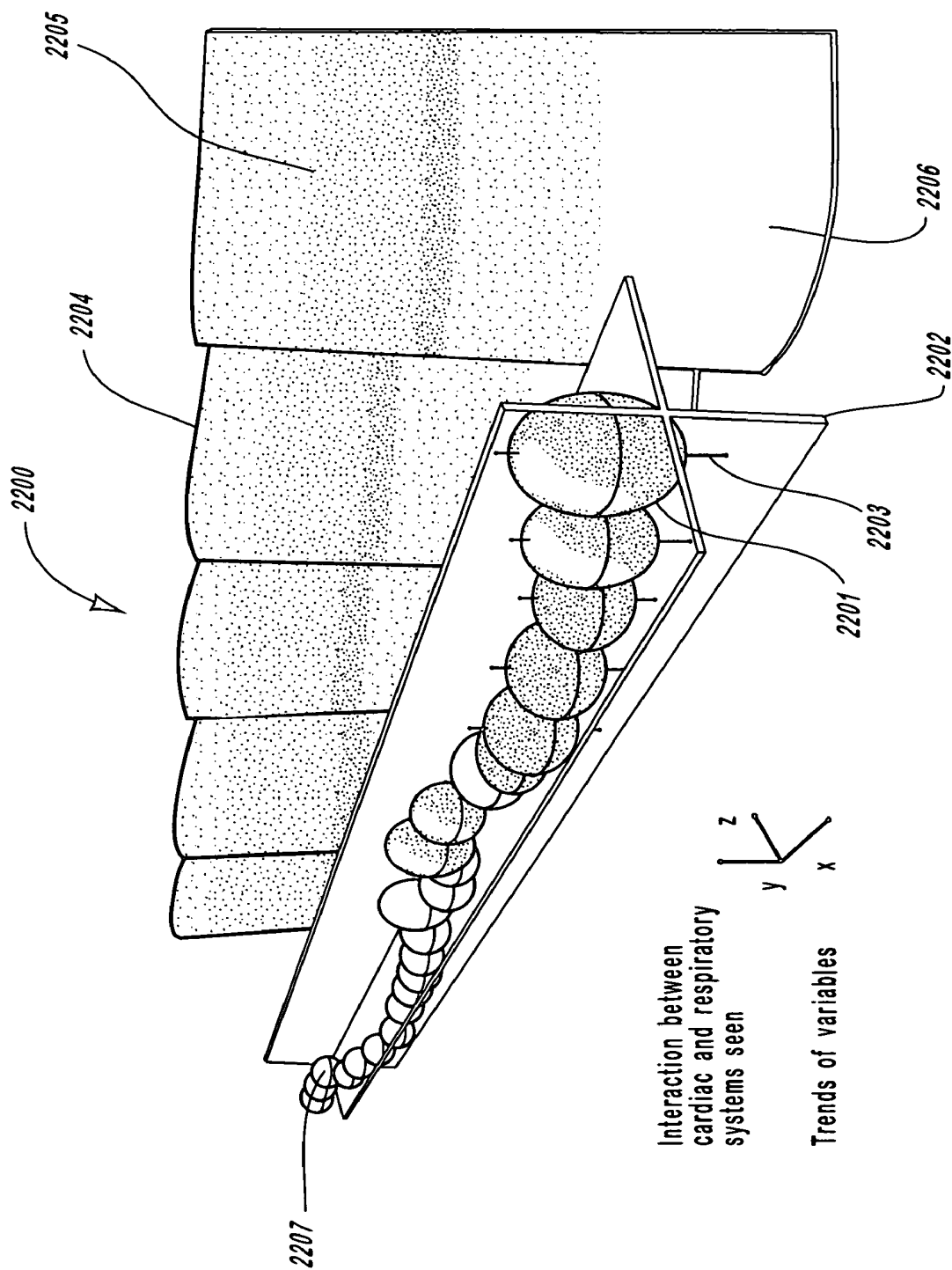

FIGURE 22

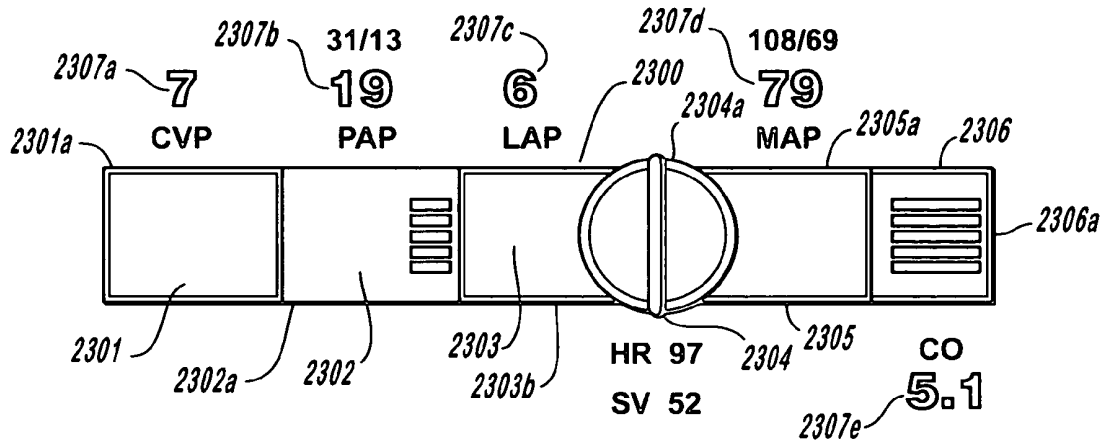

FIGURE 23a

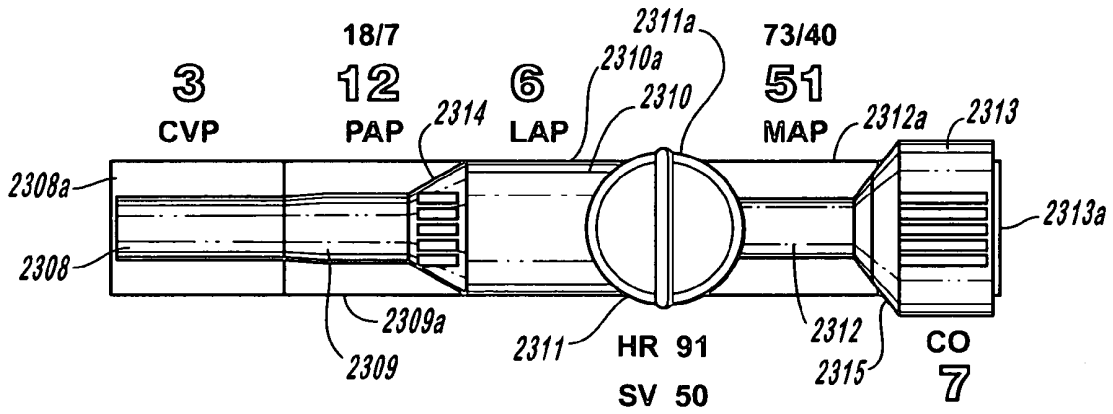

FIGURE 23b

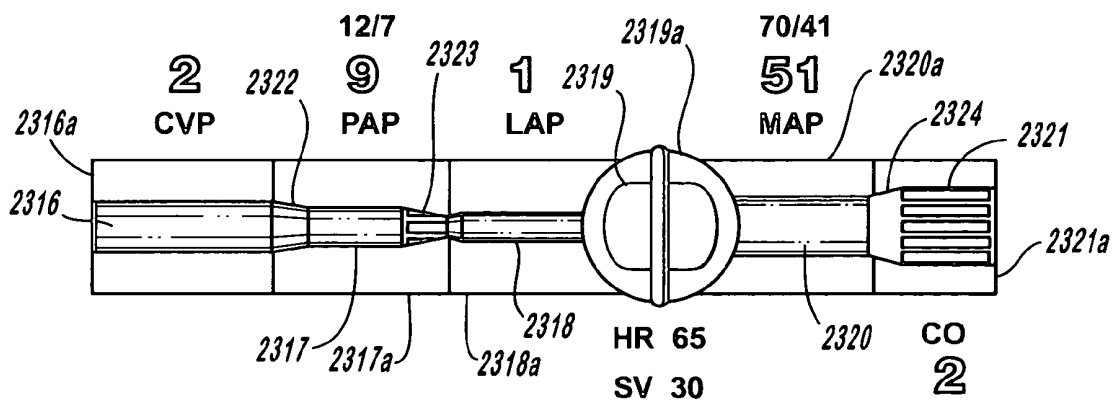

FIGURE 23c

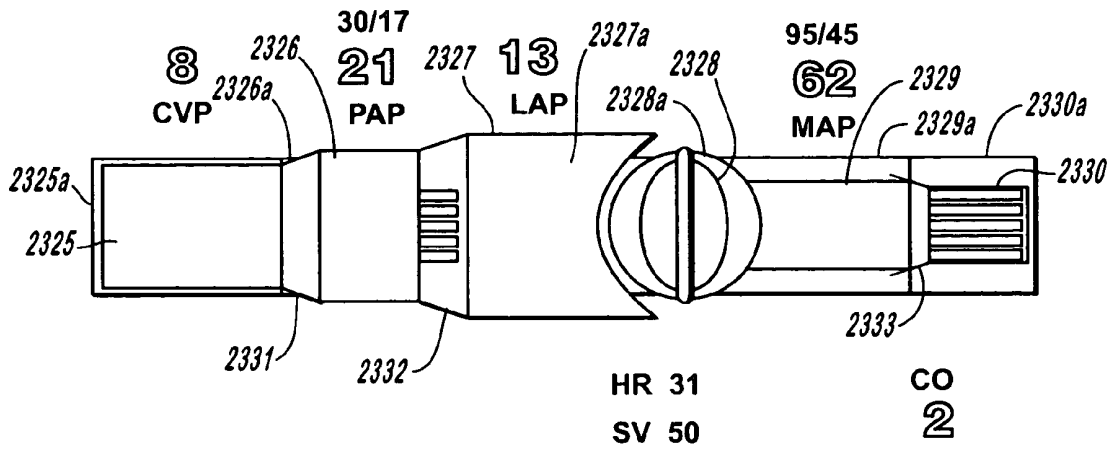

FIGURE 23d

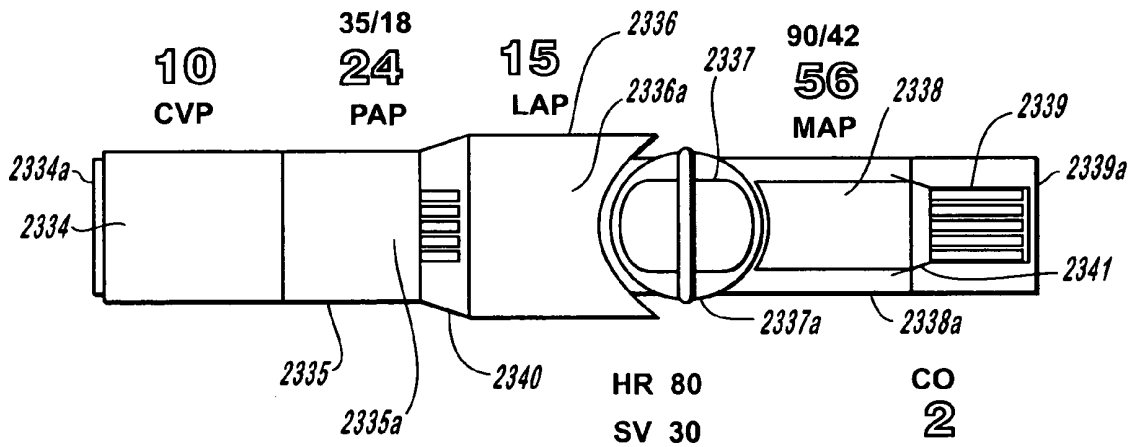

FIGURE 23e

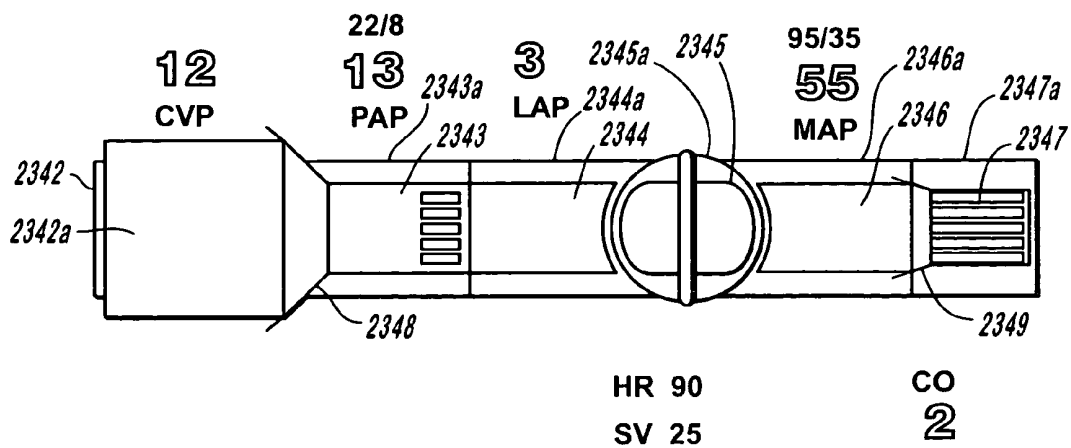

FIGURE 23f

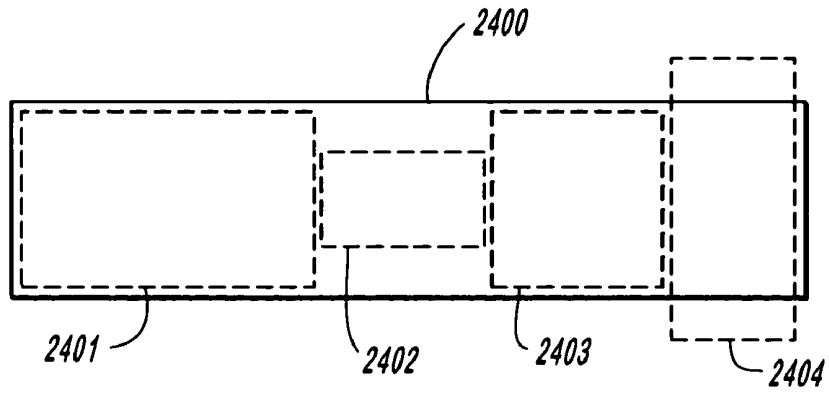

FIGURE 24

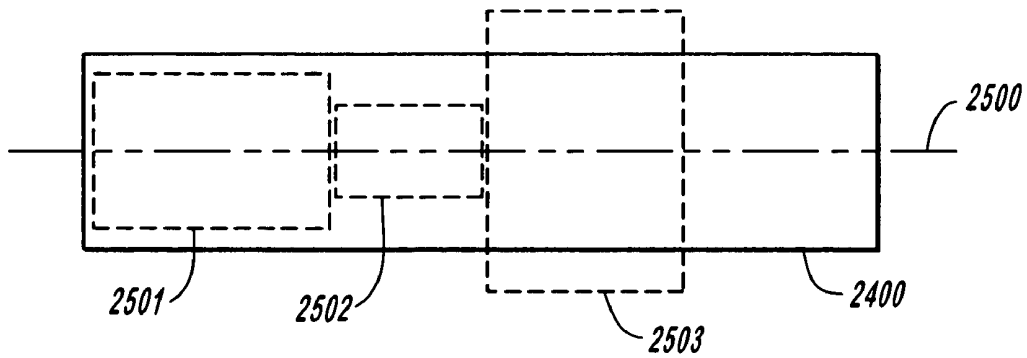

FIGURE 25

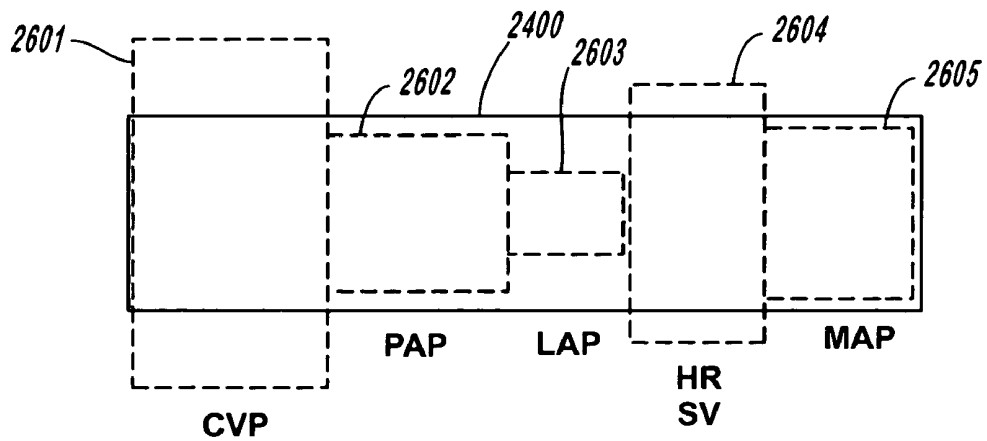

FIGURE 26

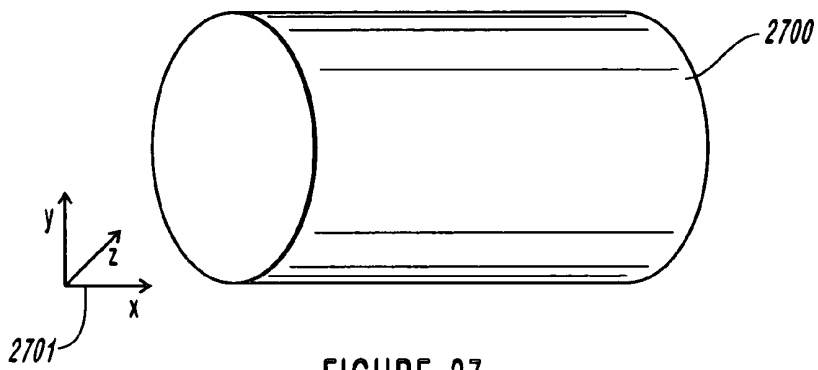

FIGURE 27

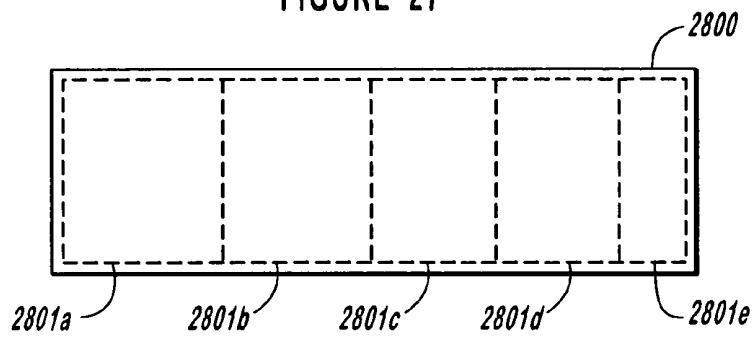

FIGURE 28

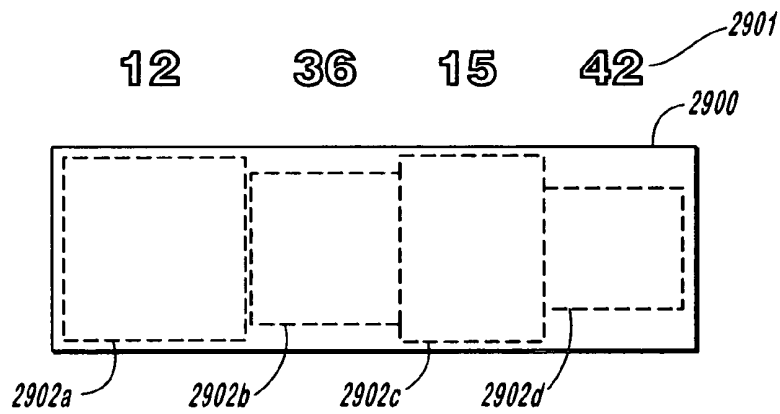

FIGURE 29

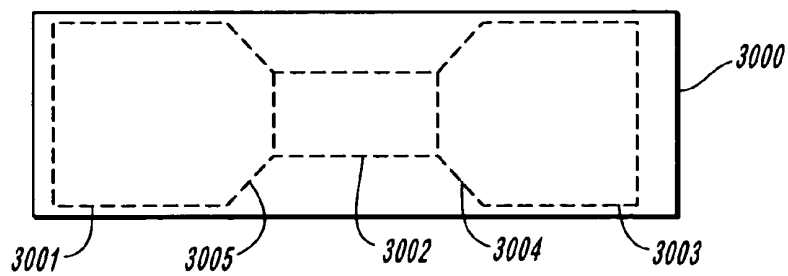

FIGURE 30

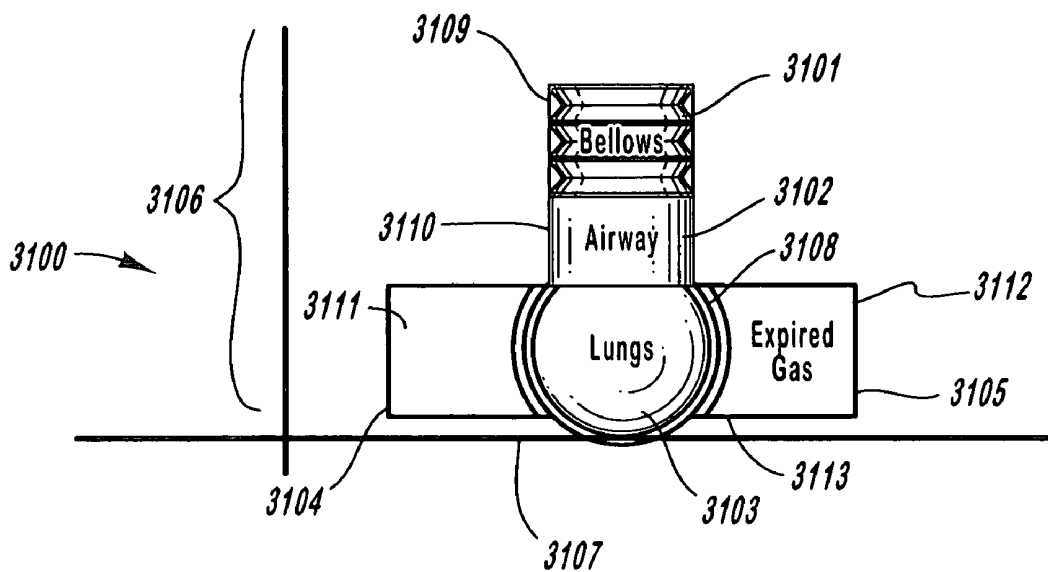

FIGURE 31

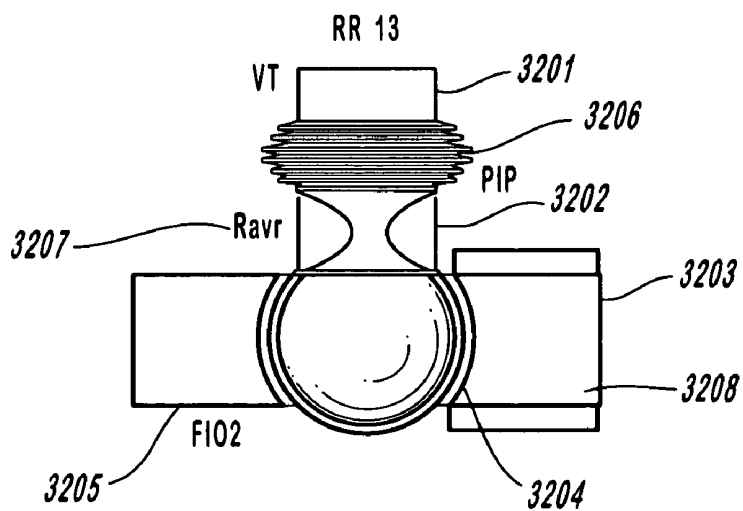

FIGURE 32

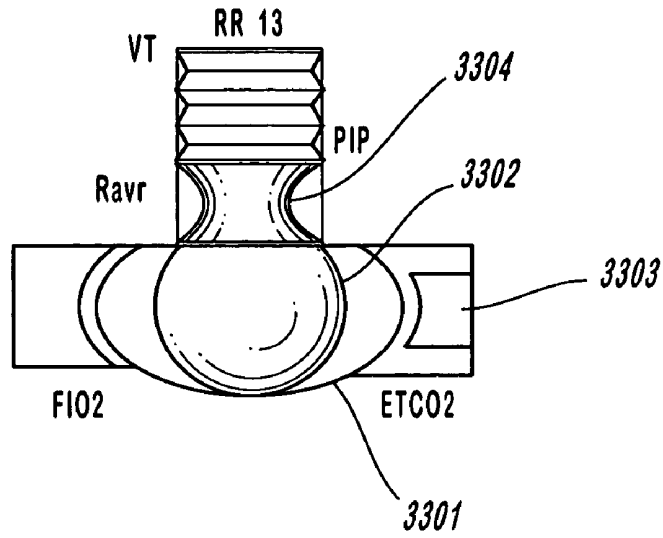

FIGURE 33

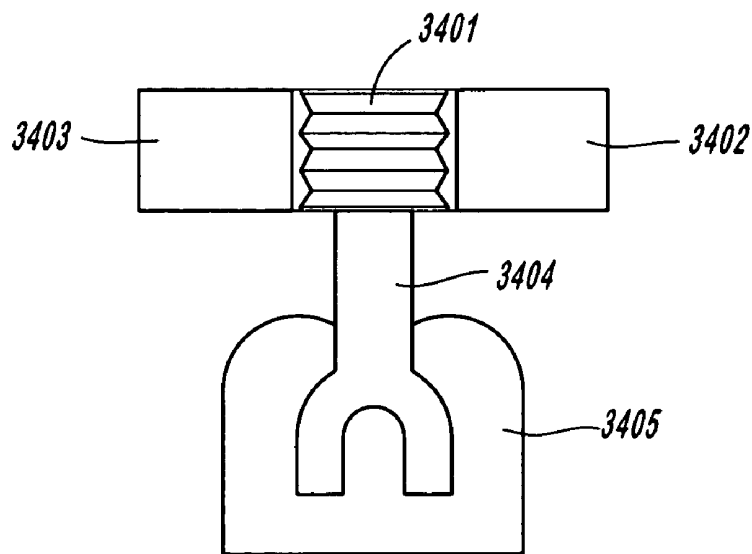

FIGURE 34

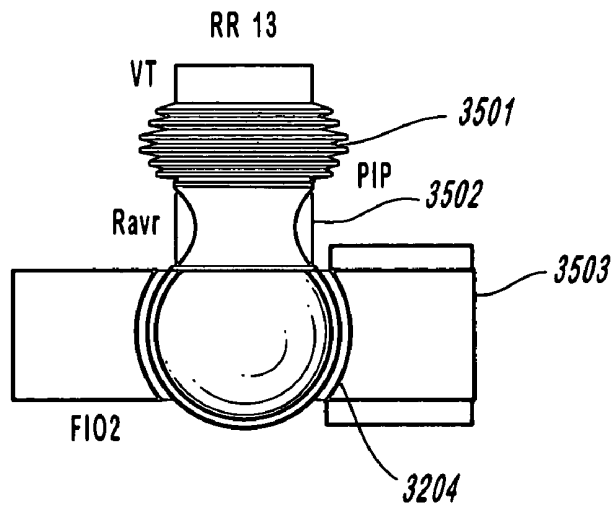

FIGURE 35

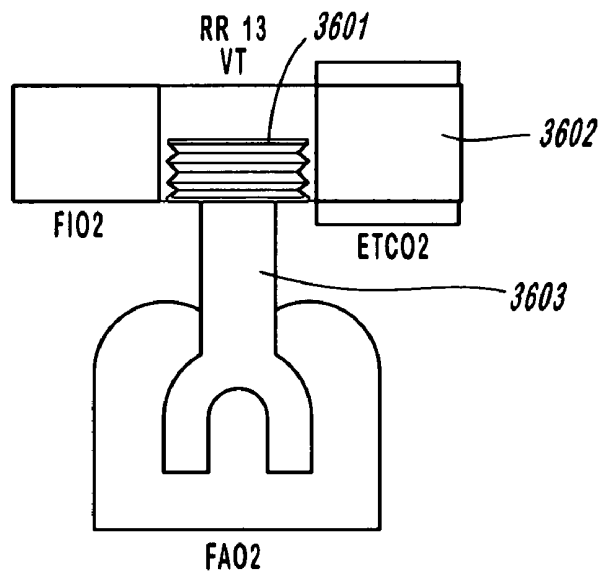

FIGURE 36

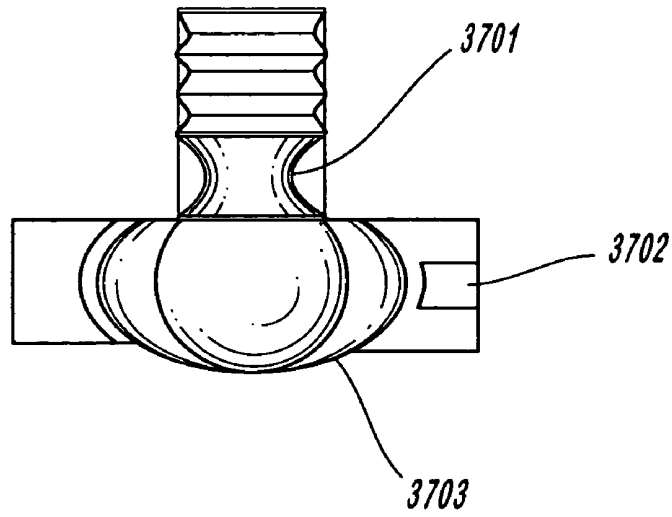

FIGURE 37

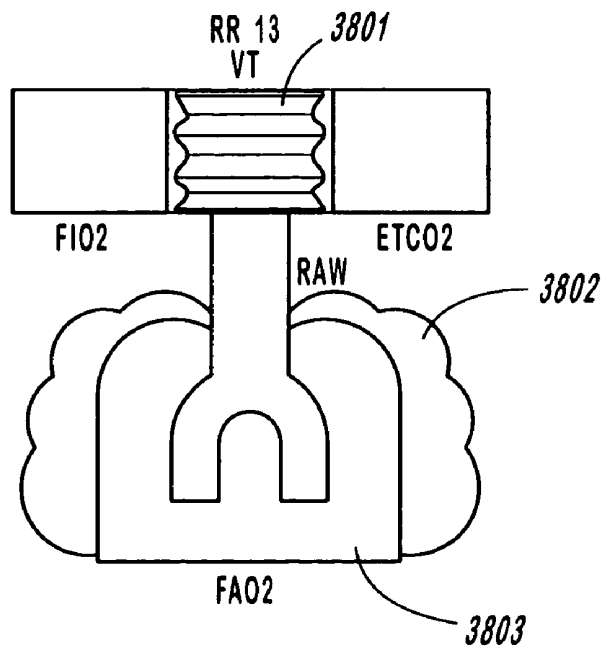

FIGURE 38

**METHOD AND APPARATUS FOR  
MONITORING DYNAMIC  
CARDIOVASCULAR FUNCTION USING  
N-DIMENSIONAL REPRESENTATIVES OF  
CRITICAL FUNCTIONS**

CROSS REFERENCE TO RELATED  
APPLICATIONS

This patent application is a continuation-in-part patent application of copending U.S. patent application Ser. No. 09/457,068, which was filed on Dec. 7, 1999 and of copending Provisional Patent Application Ser. No. 60/328,880, filed on Oct. 12, 2001. Priority is hereby claimed to all common material disclosed in these pending patent cases.

FEDERAL RESEARCH STATEMENT

Some of the technology described in this patent application was funded in part by National Institute of Health Grant No. 1R24 HL 64590 and NASA Grant No. NGTA40101.

BACKGROUND OF INVENTION

1. Field of the Invention

This invention relates to the visualization, perception, representation and computation of data relating to the attributes or conditions constituting the health state of a dynamic system. More specifically, this invention relates to the display and computation of pulmonary and cardiovascular data, in which variables constituting attributes and conditions of a dynamic physiological system can be interrelated and visually correlated in time as three-dimensional objects.

2. Description of the Related Art

A variety of methods and systems for the visualization of data have been proposed. Traditionally, these methods and systems fail to present in a real-time multi-dimensional format that is directed to facilitating a user's analysis of multiple variables and the relationships between such multiple variables. Moreover, such prior methods and systems tend not to be specifically directed to display of a patient's cardiovascular and pulmonary system by showing such variables as blood pressure, blood flow, vascular tone and the like. Prior methods typically do not process and display data in real-time, rather they use databases or spatial organizations of historical data. Generally, they also simply plot existing information in two or three dimensions, but without using three-dimensional geometric objects to show the interrelations between data. Often previous systems and methods are limited to pie charts, lines or bars to represent the data. Also, many previous systems are limited to particular applications or types of data. The flexibility and adaptability of the user interface and control is typically very limited, and may not provide flexible coordinate systems and historical-trend monitors. Other systems, which have a flexible user interface, generally require substantial user expertise in order to collect and evaluate the data, including the pre-identification of data ranges and resolution. Another common limitation of previous systems and methods is that they provide only a single or predetermined viewpoint from which to observe the data. Typically, prior systems and methods do not provide data normalcy frameworks to aid in the interpretation of the data. Furthermore, most prior methods use "icons," shapes, lines, bars, or graphs.

The state-of-the-art for pulmonary monitored data in both traditional intensive care units and anesthesiology units is the wave form and numeric display monitors. These monitors represent information in discrete variables associated with

each sensor using the display paradigm of a "single-sensor-single-indicator-display." As a result, current monitors lack integrated data. The anesthesiologist is left to collect and process all of the different data herself in a timely manner.

The anesthesiologist is faced with a fire-hose of information during every case. Numerical data, waveforms, control dials, ventilator breaths, heart rate beeps, and alarm sounds bombard the anesthesiologist from all directions. During an uneventful case, the anesthesiologist successfully monitors all the available data at a low cognitive level. However, should an unexpected event happen, the anesthesiologist must quickly ascertain if a problem exists, the causality, and the needed corrective action. Should the anesthesiologist fail at any of these tasks, an error will occur. Human error is associated with more than 80% of critical anesthesia incidents and more than 50% of anesthetic deaths.

Studies have shown that integrated information represented in a graphical metaphor does reduce detection time and time to accurately diagnose a problem in anesthesia. However, the graphical metaphors studied to date tend to be complex and lack usability testing to drive designs. As a result, the graphical interface may inadvertently increase the cognitive workload of the anesthesiologists.

For general background material, the reader is directed to U.S. Pat. Nos. 3,908,640, 4,193,393, 4,464,122, 4,519,395, 4,619,269, 4,752,893, 4,772,882, 4,813,013, 4,814,755, 4,823,283, 4,832,038, 4,875,165, 4,880,013, 4,915,757, 4,930,518, 4,989,611, 5,012,411, 5,021,976, 5,103,828, 5,121,469, 5,162,991, 5,222,020, 5,224,481, 5,262,944, 5,317,321, 5,425,372, 5,491,779, 5,568,811, 5,588,104, 5,592,195, 5,596,694, 5,626,141, 5,634,461, 5,751,931, 5,768,552, 5,774,878, 5,796,398, 5,812,134, 5,830,150, 5,836,884, 5,913,826, 5,923,330, 5,961,467, 6,042,548, and 6,090,047 each of which is hereby incorporated by reference in its entirety for the material disclosed therein.

As this disclosure employs a number of terms, which may be new to the reader, the reader is directed to the applicants' definitions section, which is provided at the beginning of the detailed description section.

SUMMARY OF INVENTION

It is desirable to provide a method, system, and apparatus, which facilitates the rapid and accurate analysis of complex and quickly changing data. Moreover, it is desirable that such a system and method include a graphic element that depicts the status of a patient's cardiovascular system by graphically showing blood pressure, blood flow, vascular tone and other cardiovascular variables. It is important that such a graphic element provide an anesthesiologist with the means to quickly assess the patient's status. It is also desirable that the element be comprised of subcomponents, which are linked together to show thereby the relationships of the various cardiovascular and pulmonary variables. Also, it is desirable that system and method be capable of analyzing time based, real-time, and historical data and that it be able to graphically show the relationships between various data.

Research studies have indicated that the human mind is better able to analyze and use complex data when it is presented in a graphic, real world type representation, rather than when it is presented in textual or numeric formats. Research in thinking, imagination and learning has shown that visualization plays an intuitive and essential role in assisting a user associate, correlate, manipulate and use information. The more complex the relationship between information, the more critically important is the communication, including audio and visualization of the data. Modern human factors

theory suggests that effective data representation requires the presentation of information in a manner that is consistent with the perceptual, cognitive, and response-based mental representations of the user. For example, the application of perceptual grouping (using color, similarity, connectedness, motion, sound etc.) can facilitate the presentation of information that should be grouped together. Conversely, a failure to use perceptual principles in the appropriate ways can lead to erroneous analysis of information.

The manner in which information is presented also affects the speed and accuracy of higher-level cognitive operations. For example, research on the “symbolic distance effect” suggests that there is a relationship between the nature of the cognitive decisions (for example, is the data increasing or decreasing in magnitude?) and the way the information is presented (for example, do the critical indices become larger or smaller, or does the sound volume or pitch rise or fall?). Additionally, “population stereotypes” suggest that there are ways to present information that are compatible with well-learned interactions with other systems (for example, an upwards movement indicates an increasing value, while a downwards movement indicates a decreasing value).

Where there is compatibility between the information presented to the user and the cognitive representations presented to the user, performance is often more rapid, accurate, and consistent. Therefore, it is desirable that information be presented to the user in a manner that improves the user’s ability to process the information and minimizes any mental transformations that must be applied to the data.

Therefore, it is the general object of this invention to provide a method and systems for presenting a three-dimensional visual and/or possibly an audio display technique that assists a doctor in the monitoring of a patient’s cardiovascular and pulmonary function.

It is a further object of this invention to provide a method and system that assists in the monitoring of a patient’s cardiovascular and/or pulmonary system through the use of a three-dimensional graphic element.

It is another object of this invention to provide a method and system that assists in the management of anesthesia care of patients, by presenting a display, which quickly shows the relationships of various cardiovascular or pulmonary variables.

It is a still further object of this invention to provide a method and system that assists in the determination of the “health” of a dynamic cardiovascular or pulmonary system, by providing visual information related to the nature or quality of the soundness, wholeness, or well-being of the system as related to historical or normative values.

Another object of this invention is to provide a method and system that assists in the determination of the functioning of a cardiovascular or pulmonary system by measuring the interaction among a set of “vital-signs” normally associated with the health of the cardiovascular system.

A still further object of this invention is to provide a method and system, which provides the gathering and use of sensor measured data, as well as the formatting and normalization of the data in a format suitable to the processing methodology.

A further object of this invention is to provide a method and system, which organizes a cardiovascular or pulmonary system’s data into relevant data sets or critical functions as appropriate.

Another object of this invention is to provide a method and system, which provides a three-dimensional health-space for mapping the cardiovascular or pulmonary system data.

It is another object of this invention to provide a method and system, which provides three-dimensional objects that

are symbols of the critical functioning of the cardiovascular or pulmonary system being monitored.

It is an object of this invention to provide a method and system that shows the relationships between several critical functions that a user wishes to monitor.

It is a further object of this invention to provide a method and system that permits an integrated and overall holistic understanding of the cardiovascular or pulmonary process being monitored.

A further object of this invention is to provide a method and system where three-dimensional objects are built from three-dimensional object primitives, including: cubes, spheres, pyramids, n-polygon prisms, cylinders, slabs.

A still further object of this invention is to provide a method and system, wherein three-dimensional objects are placed within health-space based on the coordinates of their geometric centers, edges, vertices, or other definite geometric variables.

It is a further object of this invention to provide a method and system, which has three-dimensional objects that have three spatial dimensions, as well as geometric, aesthetic and aural attributes, to permit the mapping of multiple data functions.

It is another object of this invention to provide a method and system, which shows increases and decreases in data values using changes in location, size, form, texture, opacity, color, sound and the relationships thereof in their context.

It is a still further object of this invention to provide a method and system, wherein the particular three-dimensional configuration of three-dimensional objects can be associated with a particular time and health state.

A still further object of this invention is to provide a method and system that permits the simultaneous display of the history of data objects.

Another object of this invention is to provide a method and system that provides for the selection of various user selectable viewpoints.

It is a further object of this invention to provide a method and system that provides both a global and a local three-dimensional coordinate space.

It is another object of this invention to provide a method and system that permits the use of time as one of the coordinates.

It is a still further object of this invention to provide a method and system that provides a reference framework of normative values for direct comparison with the measured data.

It is a further object of this invention to provide a method and system where normative values are based on the average historical behavior of a wide population of healthy systems similar to the system whose health is being monitored.

A further object of this invention is to provide a method and system that provides viewpoints that can be selected to be perspective views, immersive Virtual Reality views, or any orthographic views.

Another object of this invention is to provide a method and system that permits the display of a layout of multiple time-space viewpoints.

A still further object of this invention is to provide a method and system that provides for zooming in and out of a time and/or space coordinate.

It is another object of this invention to provide a method and system that permits temporal and three-dimensional modeling of data “health” states based on either pre-recorded data or real-time data, that is as the data is obtained.

Another object of this invention is to provide a method and system that presents the data in familiar shapes, colors, and locations to enhance the usability of the data.

A still further object of the invention is to provide a method and system that uses animation, and sound to enhance the usefulness of the data to the user.

It is an object of this invention to provide a method and system for the measurement, computation, display and user interaction, of complex data sets that can be communicated and processed at various locations physically remote from each other, over a communication network, as necessary for the efficient utilization of the data and which can be dynamically changed or relocated as necessary.

It is a still further object of this invention to provide a method and system for the display of data that provides both a standard and a customized interface mode, thereby providing user and application flexibility.

These and other objects of this invention are achieved by the method and system herein described and are readily apparent to those of ordinary skill in the art upon careful review of the following drawings, detailed description and claims.

#### BRIEF DESCRIPTION OF DRAWINGS

In order to show the manner that the above recited and other advantages and objects of the invention are obtained, a more particular description of the preferred embodiment of the invention, which is illustrated in the appended drawings, is described as follows. The reader should understand that the drawings depict only a preferred embodiment of the invention, and are not to be considered as limiting in scope. A brief description of the drawings is as follows:

FIG. 1a is a top-level representative diagram showing the data processing paths of the preferred embodiment of this invention.

FIG. 1b is a top-level block diagram of the data processing flow of the preferred embodiment of this invention.

FIG. 1c is a top-level block diagram of one preferred processing path of this invention.

FIG. 1d is a top-level block diagram of a second preferred processing path of this invention.

FIGS. 2a, 2b, 2c, and 2d are representative 3-D objects representing critical functions.

FIG. 3 is a representation of data objects in H-space.

FIGS. 4a and 4b are representative views of changes in data objects in time.

FIGS. 5a, 5b, 5c, 5d, 5e, 5f, 5g and 5h are representative views of properties of data objects provided in the preferred embodiment of this invention.

FIG. 6 shows a 3-D configuration of the objects in H-space in the preferred embodiment of the invention.

FIG. 7 shows H-space with a time coordinate along with local-space coordinates.

FIGS. 8a and 8b show the global level coordinate system of the preferred embodiment of this invention.

FIGS. 9a and 9b show various viewpoints of the data within H-space in the preferred embodiment of this invention.

FIG. 10 shows the transformation of an object in space in context, with a reference framework, in the preferred embodiment of this invention.

FIG. 11a shows the zooming out function in the invention.

FIG. 11b shows the zooming in function in the invention.

FIGS. 12a and 12b show a 3-D referential framework of normative values.

FIG. 13 shows the interface modes of the preferred embodiment of this invention.

FIG. 14 is a hardware system flow diagram showing various hardware components of the preferred embodiments of the invention.

FIG. 15 is a software flow chart showing the logic steps of a preferred embodiment of the invention.

FIG. 16 is a software block diagram showing the logic steps of the image computation and rendering process of a preferred embodiment of the invention.

FIG. 17 is a photograph of the 3-dimensional display of a preferred embodiment of the invention.

FIG. 18 is a close-up front view of the cardiac object and the associated reference grid of a preferred embodiment of the invention.

FIG. 19 is a view of the front view portion of the display of a preferred embodiment of the present invention showing the cardiac object in the foreground and the respiratory object in the background.

FIG. 20 is a view of the top view portion of the display of a preferred embodiment of the present invention showing the cardiac object toward the bottom of the view and the respiratory object toward the top of the view.

FIG. 21 is a view of the side view portion of the display of a preferred embodiment of the present invention showing the cardiac object to the left and the respiratory object to the right.

FIG. 22 is a view of the 3-D perspective view portion of the display of a preferred embodiment of the invention showing the cardiac object in the left foreground and the respiratory object in the right background.

FIG. 23a is a view of the preferred graphic element of this invention in a normal cardiovascular system.

FIG. 23b is a view of the preferred graphic element of this invention in a cardiovascular system showing anaphylaxis.

FIG. 23c is a view of the preferred graphic element of this invention in a cardiovascular system showing hypovolemia.

FIG. 23d is a view of the preferred graphic element of this invention in a cardiovascular system showing bradycardia.

FIG. 23e is a view of the preferred graphic element of this invention in a cardiovascular system showing ischemia.

FIG. 23f is a view of the preferred graphic element of this invention in a cardiovascular system showing pulmonary embolism.

FIG. 24 is a view of the preferred reference grid of this embodiment of the invention.

FIG. 25 is a view of the preferred reference grid showing object placement in this preferred embodiment of the invention.

FIG. 26 is a view of the preferred reference grid showing the functional object relationships in this preferred embodiment of the invention.

FIG. 27 is a representative three-dimensional object used in the present preferred embodiment of the invention.

FIG. 28 is a representative view of the normalization of the present preferred embodiment of the invention.

FIG. 29 is an integrated view showing numeric information in the present preferred embodiment of the invention.

FIG. 30 is a view showing the addition of slopes to show the restriction of blood vessels.

FIG. 31 shows an embodiment of a pulmonary metaphor 3100 with anatomical representations.

FIG. 32 shows an embodiment of a pulmonary metaphor where various features are abnormal.

FIG. 33 shows an embodiment of a pulmonary metaphor where the intrinsic PEEP has increased.

FIG. 34 shows a preferred embodiment of a pulmonary metaphor.

FIG. 35 shows an embodiment of a pulmonary metaphor wherein the patient has pulmonary fibrosis.

FIG. 36 shows an alternative embodiment of a pulmonary metaphor wherein the patient has pulmonary fibrosis.

FIG. 37 shows an embodiment of a pulmonary metaphor wherein the patient has emphysema.

FIG. 38 shows an alternative embodiment of a pulmonary metaphor wherein the patient has emphysema.

#### DETAILED DESCRIPTION

This invention is a method, system and apparatus for the visual display of complex sets of dynamic data. In particular, this invention provides the means for efficiently analyzing, comparing and contrasting data, originating from either natural or artificial systems. In its most common use the preferred embodiment of this invention is used to produce an improved cardiovascular or pulmonary display of a human or animal patient. This invention provides n-dimensional visual representations of data through innovative use of orthogonal views, form, space, frameworks, color, shading, texture, transparency, sound and visual positioning of the data. The preferred system of this invention includes one or a plurality of networked computer processing and display systems, which provide real-time as well as historical data, and which processes and formats the data into an audio-visual format with a visual combination of objects and models with which the user can interact to enhance the usefulness of the processed data. While this invention is applicable to a wide variety of data analysis applications, one important application is the analysis of health data. For this reason, the example of a medical application for this invention is used throughout this description. The use of this example is not intended to limit the scope of this invention to medical data analysis applications only, rather it is provided to give a context to the wide range of potential application for this invention.

This invention requires its own lexicon. For the purposes of this patent description and claims, the inventors intend that the following terms be understood to have the following definitions.

An “artificial system” is an entity, process, combination of human designed parts, and/or environment that is created, designed or constructed by human intention. Examples of artificial systems include manmade real or virtual processes, computer systems, electrical power systems, utility and construction systems, chemical processes and designed combinations, economic processes (including, financial transactions), agricultural processes, machines, and human designed organic entities.

A “natural system” is a functioning entity whose origin, processes and structures were not manmade or artificially created. Examples of natural systems are living organisms, ecological systems and various Earth environments.

The “health” of a system is the state of being of the system as defined by its freedom from disease, ailment, failure or inefficiency. A diseased or ill state is a detrimental departure from normal functional conditions, as defined by the nature or specifications of the particular system (using historical and normative statistical values). The health of a functioning system refers to the soundness, wholeness, efficiency or well being of the entity. Moreover, the health of a system is determined by its functioning.

“Functions” are behaviors or operations that an entity performs. Functional fitness is measures by the interaction among a set of “vital-signs” normally taken or measured using methods well known in the art, from a system to establish the system’s health state, typically at regular or defined time intervals.

“Health-space” or “H-space” is the data representation environment that is used to map the data in three or more dimensions.

“H-state” is a particular 3-D configuration or composition that the various 3-D objects take in H-space at a particular time. In other words, H-state is a 3-D snapshot of the system’s health at one point of time.

“Life-space” or “L-space” provides the present and past health states of a system in a historical and comparative view of the evolution of the system in time. This 3-D representation environment constitutes the historical or Life-space of a dynamic system. L-space allows for both continuous and categorical displays of temporal dependent complex data. In other words, L-space represents the health history or trajectory of the system in time.

“Real-Time Representation” is the display of a representation of the data within a fraction of a second from the time when the event of the measured data occurred in the dynamic system.

“Real-Time User Interface” is the seemingly instantaneous response in the representation due to user interactivity (such as rotation and zooming).

A “variable” is a time dependent information unit (one unit per time increment) related to sensing a given and constant feature of the dynamic system.

“Vital signs” are key indicators that measure the system’s critical functions or physiology. In the preferred embodiments of this invention, data is gathered using methods or processes well known in the art or as appropriate and necessary. For example, in general, physiologic data, such as heart rate, respiration rate and volume, blood pressure, and the like, is collected using the various sensors that measure the functions of the natural system. Sensor-measured data is electronically transferred and translated into a digital data format to permit use by the invention. This invention uses the received measured data to deliver real-time and/or historical representations of the data and/or recorded data for later replay. Moreover, this invention permits the monitoring of the health of a dynamic system in a distributed environment. By distributed environment, it is meant that a user or users interacting with the monitoring system may be in separate locations from the location of the dynamic system being monitored. In its most basic elements, the monitoring system of this invention has three major logical components: (1) the sensors that measure the data of the system; (2) the networked computational information systems that computes the representation and that exchanges data with the sensors and the user interface; and (3) the interactive user interface that displays the desired representation and that interactively accepts the users’ inputs. The components and devices that perform the three major functions of this invention may be multiple, may be in the same or different physical locations, and/or may be assigned to a specific process or shared by multiple processes.

FIG. 1a is a top-level representative diagram showing the data processing paths of the preferred embodiment of this invention operating on a natural system. The natural system 101a is shown as a dynamic entity whose origin, processes and structures (although not necessarily its maintenance) were not manmade or artificially created. Examples of natural systems are living organisms, ecological systems, and various Earth environments. In one preferred embodiment of the invention, a human being is the natural system whose physiology is being monitored. Attached to the natural system 101a are a number of sensors 102. These sensors 102 collect the physiologic data, thereby measuring the selected critical functions of the natural system. Typically, the data gathering

of the sensors **102** is accomplished with methods or techniques well known in the art. The sensors **102** are typically and preferably electrically connected to a digital data formatter **103**. However, in other embodiments of this invention, the sensors may be connected using alternative means including but not limited to optical, RF and the like. In many instances, this digital data formatter **103** is a high-speed analog to digital converter. Also, connected to the digital data formatter **103** is the simulator **101b**. The simulator **101b** is an apparatus or process designed to simulate the physiologic process underlying the life of the natural system **101a**. A simulator **101b** is provided to generate vital sign data in place of a natural system **101a**, for such purposes as education, research, system test, and calibration. The output of the digital data formatter **103** is Real-Time data **104**. Real-Time data **104** may vary based on the natural system **101a** being monitored or the simulator **101b** being used and can be selected to follow any desired time frame, for example time frames ranging from one-second periodic intervals, for the refreshment rates of patients in surgery, to monthly statistics reporting in an ecological system. The Real-Time data **104** is provided to a data recorder **105**, which provides the means for recording data for later review and analysis, and to a data modeling processor and process **108**. In the preferred embodiments of this invention the data recorder **105** uses processor controlled digital memory, and the data modeling processor and process **108** is one or more digital computer devices, each having a processor, memory, display, input and output devices and a network connection. The data recorder **105** provides the recorded data to a speed controller **106**, which permits the user to speed-up or slow-down the replay of recorded information. Scalar manipulations of the time (speed) in the context of the 3-D modeling of the dynamic recorded digital data allows for new and improved methods or reviewing the health of the systems **101a,b**. A customize/standardize function **107** is provided to permit the data modeling to be constructed and viewed in a wide variety of ways according to the user's needs or intentions. Customization **107** includes the ability to modify spatial scale, such modifying includes but is not limited to zooming, translating, and rotating, attributes and viewports in addition to speed. In one preferred embodiment of the invention, the range of customization **107** permitted for monitoring natural systems **101a** physiologic states is reduced and is heavily standardized in order to ensure that data is presented in a common format that leads to common interpretations among a diverse set of users. The data modeling processor and process **108** uses the prescribed design parameters, the standardized/customize function and the received data to build a three-dimensional (3-D) model in real-time and to deliver it to an attached display. The attached display of the data modeling processor and process **108** presents a representation **109** of 3-D objects in 3-D space in time to provide the visual representation of the health of the natural system **101a** in time, or as in the described instances of the simulated **101b** system.

FIG. **1b** is a top-level block diagram of the data processing flow of the preferred embodiment of this invention operating on an artificial system. An artificial system is a dynamic entity whose origin, processes and structure have been designed and constructed by human intention. Examples of artificial systems are manmade real or virtual, mechanical, electrical, chemical and/or organic entities. The artificial system **110a** is shown attached to a number of sensors **111**. These sensors **111** collect the various desired data, thereby measuring the selected critical functions of the artificial system. Typically, the data gathering of the sensors **111** is accomplished with methods or techniques well known in the art. The sensors **111**

are connected to a data formatter **112**, although alternative connection means including optical, RF and the like may be substituted without departing from the concept of this invention. In many instances, this digital data formatter **112** is a high-speed analog to digital converter. Although, in certain applications of the invention, namely stock market transactions, the data is communicated initially by people making trades. Also connected to the digital data formatter **112** is the simulator **110b**. The simulator **110b** is an apparatus or process designed to simulate the process underlying the state of the artificial system **110a**. The simulator **110b** is provided to generate vital data in place of the artificial system **110a**, for such purposes as education, research, system test, and calibration. The output of the digital data formatter **112** is Real-Time data **113**. Real-Time data **113** may vary based on the artificial system **110a** being monitored or the simulator **110b** being used and can be selected to follow any desired time frame, for example time frames ranging from microsecond periodic intervals, for the analysis of electronic systems, to daily statistics reported in an financial trading system. The Real-Time data **113** is provided to a data recorder **114**, which provides the means for recording data for later review and analysis, and to a data modeling processor and process **117**. In the preferred embodiments of this invention the data recorder **114** uses processor controlled digital memory, and the data modeling processor and process **117** is one or more digital computer devices, each having a processor, memory, display, input and output devices and a network connection. The data recorder **114** provides the recorded data to a speed controller **115**, which permits the user to speed-up or slow-down the replay of recorded information. Scalar manipulations of the time (speed) in the context of the 3-D modeling of the dynamic recorded digital data allows for new and improved methods or reviewing the health of the system **110a,b**. A customize/standardize function **116** is provided to permit the data modeling to be constructed and viewed in a wide variety of ways according to the user's needs or intentions. Customization **116** includes the ability to modify spatial scale (such modification including, but not limited to translating, rotating, and zooming), attributes, other structural and symbolic parameters, and viewports in addition to speed. The range of customization form monitoring artificial systems' **110a,b** states is wide and not as standardized as that used in the preferred embodiment of the natural system **101a,b** monitoring. In this Free Customization, the symbolic system and display method is fully adaptable to the user's needs and interests. Although this invention has a default visualization space, its rules, parameters, structure, time intervals, and overall design are completely customizable. This interface mode customize/standardize function **116** also allows the user to select what information to view and how to display the data. This interface mode customization **116** may, in some preferred embodiments, produce personalized displays that although they may be incomprehensible to other users, facilitate highly individual or competitive pursuits not limited to standardized interpretations, and therefore permit a user to look at data in a new manner. Such applications as analysis of stock market data or corporation health monitoring may be well suited to the flexibility of this interface mode. The data modeling processor and process **117** uses the prescribed design parameters, the customize/standardized function **116** and the received real-time data **113** to build a three-dimensional (3-D) model in time and to deliver it to a display. The display of the data modeling processor and process **117** presents a representation **118** of 3-D objects in 3-D space in time

to provide the visual representation of the health of the artificial system **110a** in time, or as in the described instances of the simulated **110b** system.

FIG. **1c** is a top-level block diagram of one preferred processing path of this invention. Sensors **119** collect the desired signals and transfer them as electrical impulses to the appropriate data creation apparatus **120**. The data creation apparatus **120** converts the received electrical impulses into digital data. A data formatter **121** receives the digital data from the data creation apparatus **120** to provide appropriate formatted data for the data recorder **122**. The data recorder **122** provides digital storage of data for processing and display. A data processor **123** receives the output from the data recorder **122**. The data processor **123** includes a data organizer **124** for formatting the received data for further processing. The data modeler **125** receives the data from the data organizer and prepares the models for representing to the user. The computed models are received by the data representer **126**, which formats the models for presentation on a computer display device. Receiving the formatted data from the data processor **123** are a number of data communication devices **127**, **130**. These devices **127**, **130** include a central processing unit, which controls the image provided to one or more local displays **128**, **131**. The local displays may be interfaced with a custom interface module **129** which provides user control of such attributes as speed **131**, object attributes **132**, viewports **133**, zoom **134** and other like user controls **135**.

FIG. **1d** is a top-level block diagram of a second preferred processing path of this invention. In this embodiment of the invention a plurality of entities **136a, b, c** are attached to sensors **137a, b, c** which communicate sensor data to a data collection mechanism **138**, which receives and organizes the sensed data. The data collection mechanism **138** is connected **139** to the data normalize and formatting process **140**. The data normalize and formatting process **140** passes the normalized and formatted data **141** to the distributed processors **142**. Typically and preferably the processing **142** is distributed over the Internet, although alternative communication networks may be substituted without departing from the concept of this invention. Each processing unit **142** is connected to any of the display devices **143a, b, c** and receives command control from a user from a number of interface units **144a, b, c**, each of which may also be connected directly to a display devices **143a, b, c**. The interface units **144a, b, c** receive commands **145** from the user that provide speed, zoom and other visual attributes controls to the displays **143a, b, c**.

FIGS. **2a**, **2b**, **2c**, and **2d** are representative 3-D objects representing critical functions. Each 3-D object is provided as a symbol for a critical function of the entity whose health is being monitored. The symbol is created by selecting the interdependent variables that measure a particular physiologic function and expressing the variable in spatial (x,y,z) and other dimensions. Each 3-D object is built from 3-D object primitives (i.e., a cube, a sphere, a pyramid, a n-polygon prism, a cylinder, a slab, etc.). More specifically, the spatial dimensions (extensions X, Y and Z) are modeled after the most important physiologic variables based on (1) data interdependency relationships, (2) rate, type and magnitude of change in data flow, (3) geometric nature and perceptual potential of the 3-D object, for example a pyramid versus a cylinder, (4) potential of the object's volume to be a data-variable itself by modeling appropriate data into x, y and z dimensions (e.g., in one preferred application of the invention, cardiac output is the result of heart rate (x and y dimensions) and stroke volume (z)), (5) orthographic viewing potential (see viewport) and (6) the relationship with the normal values framework.

The first representative object **201**, shown in FIG. **2a**, is an engine process. The object **201** representing this process is provided on a standard x-y-z coordinate axis **202**. The correlation between temperature, shown in the x1-dimension **204**, engine RPM, shown in the y1-dimension **205** and exhaust gas volume, shown in the z1-dimension **203** is shown by changes in the overall sizes and proportion of the object **201**. In the shown example object **201** the engine gas volume **203** is large, when RPM **205** is low and the engine temperature **204** is in the middle range. This combination of values, even without specific identified values suggests an engine's starting point.

The second representative object **206**, shown in FIG. **2b**, is an object representing cardiac function using stroke volume, in the y2-dimension **209**, and the heart rate per second, shown as the x2, z2 dimensions. The total cardiac volume is shown as the total spherical volume **208**.

The third representative object **211**, shown in FIG. **2c**, represents the interaction between the number of contracts, shown in the y3-dimension **212**, the average revenue per contract, shown in the z3-dimension **214**, and the average time per contract, shown in the x3-dimension **213**. Assessing the interaction among these variables is important in monitoring of a sales department's operations.

The fourth representative object **215** is shown in FIG. **2d**, shows the respiratory function generated by the respiratory rate, shown in x4-dimension **216**, the respiratory volume, shown in the y4-dimension **216**, and inhalation/exhalations, shown in the z4-dimension **218**.

FIG. **3** is a representation of data objects in H-space **301**. Data sets are represented as 3-D objects of various characteristics and relationships within a 3-D representation space. The data representation environment in this figure is used to map the physiologic data in 3-D and is what is referred to as "Health-space" or "H-space"**301**. The 3-D objects are placed within H-space on the 3 coordinates of their geometric centers. The coordinates for an object's geometric center depends on the relevant data associated to the particular critical function the object represents. For example, in the preferred embodiment, the cardiac function object, shown as a spherical object **302**, is placed in H-space **301** based on Mean Blood Pressure, designated as Oy **306** and Oxygen Saturation in the Blood, shown as Oz **307**. In the other example object, the prism **309** is placed in H-space **301** depending on sales profit, shown as Py **312**, and products in stock, shown as Pz, **311**. The location of 3-D objects in H-space **301** allows for the overall extension envelope of H-space, the relationship between 3-D objects and spaces within H-space **301**, the viewport display areas and the departure from normative values. Typically and preferably the centers of the objects **302**, **309** are located in the middle of the x-dimension of H-space **301**.

FIGS. **4a** and **4b** are representative views of changes in data objects in time. In FIG. **4a**, the x-coordinate **400** is used to measure the temporal dimension of an objects **402** trajectory. The y-z plane **401a** determines the location of an object's geometric center within H-space. Increases or decreases in data values associated with the coordinates of the object's geometric center that make that object's location change in time as shown in path line **401b**. In this view, the object **402** is presented in four different time intervals **403**, **404**, **405**, **406**, thereby creating a historical trajectory. The time intervals at which the object **402** is shown are provided **407**. In FIG. **4b**, increases in size and proportion are presented, **408**, **409**, **410**, **411** providing an example of changes in values. The monitoring of these changes in time assists the user establish and evaluate comparative relationships within and across H-states.

FIGS. 5a, 5b, 5c, 5d, 5e, 5f, 5g and 5h are representative views of properties of data objects provided in the preferred embodiment of this invention. In addition to the three x-y-z spatial dimensions used for value correlation and analysis, 3-D objects may present data value states by using other geometric, aesthetic, and aural attributes that provide for the mapping of more physiologic data. These figures show some of the representative other geometric, aesthetic, and aural attributes supported for data presentation in this invention. FIG. 5a shows changes in apparent volumetric density. A solid object 501 is shown in relation to a void object 502 and an intermediate state 503 object. FIG. 5b shows changes in apparent 3-D enclosure. An open object 504, a closed object 505, and an intermediate state 506 is shown. FIG. 5c shows the apparent degree of formal deformation. A normal object 507, a distorted object 508, a transformed object 509, and a destroyed object 510 are shown in comparison. FIG. 5d shows secondary forms of the objects. "Needles" 513 protruding through a standard object 512 in combination 511 is shown in comparison with a boundary 515 surrounding a standard object 514 and a bar 517 protruding into the original form object 518 forming a new combination object 516 are shown providing additional combination supported in this invention. FIG. 5e shows the various degrees of opacity of the object's surface, showing an opaque object 519, a transparent object 520 and an intermediate state object 521. FIG. 5f shows the various degrees of texture supported by the object display of this invention, including a textured object 522, a smooth object 523 and an intermediate textured object 524. FIG. 5g is intended to represent various color hue possibilities supported for objects in this invention. An object with color hue is represented 525 next to a value hue object 526 and a saturation hue object 527 for relative comparison. Naturally, in the actual display of this invention colors are used rather than simply the representation of color shown in FIG. 5g. FIG. 5h shows the atmospheric density of the representation space possible in the display of objects in this invention. An empty-clear space 528, a full-dark space 530 and an intermediate foggy space 523 are shown with 3-D objects shown within the representative space 529, 531, 533.

Aural properties supported in this invention include, but are not limited to pitch, timbre, tone and the like.

FIG. 6 shows the 3-D configuration of the objects in H-space in the preferred embodiment of the invention. In this view the local level, H-space 601 is shown within which the 3-D objects 602, 603, and 604 are located. Object 602 represents the respiratory function of an individual. Its 602 x-y-z dimensions change based on the parameter-based dimensional correlation. The object 603 represents the efficiency of the cardiac system by varying the x,y,z coordinates of the object. The object 604 represents a human brain function, also with the x,y,z dimensions changing based on the parameter-based dimensional correlation. In this way the user can easily view the relative relationships between the three physiological objects 602, 603, 604. Within H-space 601, the temporal coordinate (i.e., periodic time interval for data capturing that defines how H-space is plotted in Live-space see FIG. 7) is a spatial dimension on which data is mapped. The x-dimension of 605 of the H-space 601 can be mapped to another independent variable such as heart rate period, blood pressure or the like. The location of an object in the y-dimension 606 of H-space 601 can be mapped to additional variables that are desired to be monitored such as SaO2 content, CaO2 content, or temperature in the blood. The location of an object in the z-dimension 607 of the H-space 601 can also be mapped to additional variables that the user desires to monitor. A hypothetical object 608 shows that the three coordinates are con-

textual to a particular object 608 and need not be the same for all objects, except in the object's 608 extension measuring properties. Fixed x- and z-dimension values 609a and 609b are shown as constant. The y-value 610 of this object 608 changes to fluctuating values or data type that results in the height of the object 608 increasing or decreasing. This view shows another object 611 showing the relationship between the three dimensions. Constant x- and y-values 612a and 612b are shown. The z-value 613 of this object 611 changes to fluctuating values or data types that result in the width of the object 611 increasing or decreasing. An overlapping view 614 of an object 615 that has extended past the H-space limitation. A limit of H-space 616 with a spherical object 617 located inside H-space 616 shown with the degree of extension shown in shaded circles.

FIG. 7 shows a series of H-spaces 701, 702, 703, 704, 705, 706 along a global time coordinate 708, and the local-space coordinates 707 that governs each H-space. Each of these H-spaces represents progressive states of the dynamic system at pre-established temporal intervals ( $T_0, T_{-1}, T_{-2}, \dots T_{-n}$ ) and the six 701, 702, 703, 704, 705, 706 together show the evolution of that system over time, demonstrating the historical representation of individual H-states within an overall "Life-space" or "L-space." At the global level (or L-space), one of the coordinates, typically x, is always time. The temporal coordinate is scaled based on the intervals at which a particular functions system's physiologic data are collected by the art or as appropriate. This interval or module is fixed and constant across L-space and provides the necessary temporal frame of reference for comparing different H-spaces. The fixed temporal interval also determines the maximum x-extension of the representation envelope of H-space. The other two coordinates, y and z, provide L-space with extension and are not fixed. The three coordinates thus described provide a regulating 3-D environment within which the H-states can be visualized and related to each other.

FIGS. 8a and 8b show the global level coordinate system of the preferred embodiment of this invention. FIG. 8a shows the L-space coordinate system 801 in its preferred embodiment. The x-dimension 802 of L-space is mapped to a constant time interval, set by means standard in the art or otherwise as appropriate. The present position of H-state is also indicated on the x-dimension 802. The y-dimension 803 in both positive and negative extensions is measured, up and down from the x-axis. This dimension 803 can be mapped to a data variable within particular 3D object in space. The z-dimension 804 is shown in both positive and negative extensions measured forwards and backwards from the intersecting x-axis. This dimension 804 can be mapped to a data variable within a particular 3D object in space. Now for FIG. 8b a prismatic object 800 represents a critical function, whose evolution is being monitored in L-space, of a given dynamic system. The front view 805 shows the different H-states of the prism/function 800 using a time T to T-n historical trend. The level of intersection and separation between the front views of the prism indicate abnormal health states of the critical function the object 800 represents. No separation or intersection shows normal function conditions. The trajectory in the y-dimension of the prism (i.e., H-states of the critical function) are mapped to a variable that cause their relative position to change in the + and y dimension. The current state 806 of the prism is shown in this front view 805. A top view of 809 of the three-dimensional L-space is shown, showing the evolution of the prism 800 backward in time and showing a T to T-N historical trend. The level of intersection and separation indicate abnormal health states of the particular critical function the prism represents. No separation or intersection shows

normal conditions. The trajectory in the z-dimension of the object is mapped to a variable that causes their position to change in the x and z dimension. This top view shows both the z and y trajectories in one comprehensive view. The perspective view **808** of L-space gives a comprehensive view of the interaction of the prisms (the H-states of the function) and their movement in all dimensions. The side view **807** of L-space shows the prisms and their positions in L-space giving a simultaneous view of z and y trajectories.

FIGS. **9a** and **9b** shows various viewpoints in which the data may be visualized in the preferred embodiment of this invention. This figure shows representations of a data object (a prism) and is provided to show that there are two basic types of viewports: orthographic and perspectival. The orthographic viewports **906**, **907**, **908**, of FIG. **9b** use a parallel system of projection to generate representations of H-space that maintains dimensional constancy without deformation. Some examples of orthographic views include traditional architectural or engineering views of objects, such as a top view, a front view, and a side view. The orthographic viewport allows for accurate and focused 2-D expressions of the actual 3-D object. The perspectival viewport **909**, shown in FIG. **9b** uses a focal system of projection to generate depictions analogous to our perception of reality but at the cost of deformation and lack of dimensional constancy. For example, the top view **902** along with the side view **903** and the front view of **904** of the 3-D data object **901** are shown in FIG. **9a**. FIG. **9b** shows three orthogonal views **906**, **907**, **908** along with a perspective view **909** of the current data object. The number and types of viewports used in a particular embodiment of the invention may range from one type, for example a perspective viewport allowing immerse virtual reality, to combinations of both types. In the preferred current embodiment, there are the four viewports shown in FIG. **9b**. Given the 3-D nature of data objects and H-space, viewports provide the user with different depictions of the same data.

FIG. **10** shows the transform of an object in space in context, with a reference framework, in the preferred embodiment of this invention. The referential framework **1010** is typically set based on population normals or patient normals. This framework assists the user to see deviations from normal very quickly. An individual spherical object **1011** that represents cardiac function is shown located in L-space and in relation to the referential framework. A side view **1012** is shown along with several cardiac objects. In this view the referential framework provides a center target point so that a user can make the necessary corrections to bring the object back to the ideal center of the framework. A perspectival view **1013** of the framework is also shown along with several cardiac objects. The top view **1014** of the framework is shown with several spherical objects (representing cardiac states). This figure demonstrates the variety of viewports provided to the user by this invention, which provides enhanced flexibility of analysis of the displayed data.

FIG. **11a** shows the zooming out function in the invention. This invention provides a variety of data display functions. This figure shows the way views may be zoomed in and out providing the relative expansion or compression of the time coordinate. Zooming out **1101** permits the user to look at the evolution of the system's health as it implies the relative diminution of H-states and the expansion of L-space. This view **1101** shows a zoomed out view of the front view showing a historical view of many health states. A side view **1102** zoomed out view is provided to show the historical trend stacking up behind the current view. A 3-D perspectival, zoomed out view **1103** showing the interaction of H-states

over a significant amount of time is provided. A zoomed out top view **1104** shows the interaction of H-states over a large amount of time.

FIG. **11b** shows the zooming in function of the invention. The zooming in front view **1105** is shown providing an example of how zooming in permits a user to focus in on one or a few H-states to closely study specific data to determine with precision to the forces acting on a particular H-state. A zoomed in side view **1106** is provided showing the details of specific variables and their interactions. A zoomed in 3-D perspective view **1107** of a few objects is also shown. Also shown is a zoomed in top view **1108** showing the details of specific variables and their interaction.

FIG. **12a** shows a 3-D referential framework of normative values that is provided to permit the user a direct comparison between existing and normative health states, thereby allowing rapid detection of abnormal states. The reference framework **1201** works at both the global L-space level and the local H-space level. "Normal" values are established based on average historical behavior of a wide population of systems similar to the one whose health is being monitored. This normal value constitutes the initial or by-default ideal value, which, if necessary may be adjusted to acknowledge the particular characteristics of a specific system or to follow user-determined specifications. The highest normal value of vital sign "A" **1202** (+y) is shown, along with the lowest normal value of "B" **1203** (-z), the lowest normal value of vital sign "A" **1204** (-y) and the highest normal value of vital sign "B" **1205** (+z). In FIG. **12b**, abnormal values of "A" and "B" are shown in an orthogonal view. An abnormally high value of "A" **1206**, an abnormally low value of "B" **1207**, an abnormally low value of "A" **1208** and an abnormally high value of "B" **1209** are shown.

FIG. **13** shows a comparison of the interface modes of the preferred embodiment of this invention. This invention provides two basic types of interface modes: (a) standardized or constrained customization; and (b) free or total customization. Each is directed toward different types of applications. The standardized or constrained customization **1301** uses a method and apparatus for user interface that is set a-priori by the designer and allows little customization. This interface mode establishes a stable, common, and standard symbolic system and displaying method that is "user-resistant". The fundamental rules, parameters, structure, time intervals, and overall design of L-space and H-space are not customizable. Such a normalized symbolic organization creates a common interpretative ground upon which different users may arrive at similar conclusions when provided common or similar health conditions. This is provided because similar data flows will generate similar visualization patterns within a standardized symbolic system. This interface method is intended for social disciplines, such as medicine in which common and agreeable interpretations of the data are highly sought after to ensure appropriate and verifiable monitoring, diagnosis and treatment of health states. The customization permitted in this mode is minimal and is never threatening to render the monitoring device incomprehensible to other users.

The free or total customization interface mode **1302** provides a symbolic system and displaying method that is changeable according to the user's individual needs and interests. Although the invention comes with a default symbolic L-space and H-space, its rules, parameters, structure, time intervals, and overall design are customizable. This interface mode also permits the user to select what information the user wishes to view as well as how the user wishes to display it. This interface mode may produce personalized displays that are incomprehensible to other users, but provides flexibility

that is highly desired in individual or competitive pursuits that do not require agreeable or verifiable interpretations. Examples of appropriate applications may include the stock market and corporate health data monitoring.

FIG. 14 is a hardware system flow diagram showing various hardware components of the preferred embodiments of the invention in a "natural system" medical application. Initially a decision **1401** is made as to the option of using data monitored on a "real" system, that is a real patient, or data from the simulator, for anesthesiology training purposes. If the data is from a real patient, then the patient **1402** is provided with patient sensors **1404**, which are used to collect physiological data. Various types of sensors, including but not limited to non-invasive BP sensors, ECG leads, SaO<sub>2</sub> sensors and the like may be used. Digital sensors **1416** may also provide physiological data. An A/D converter **1405**, is provided in the interface box, which receives the analog sensor signals and outputs digital data to a traditional patient monitor **1406**. If the data is produced **1401** by the simulator **1403**, a control box and mannequins are used. The control box controls the scenarios simulated and the setup values of each physiological variable. The mannequins generate the physiological data that simulates real patient data and doctors collect the data through different, but comparable sensors. The traditional patient monitor **1406** displays the physiological data from the interface box on the screen. Typically and preferably, this monitor **1406** is the monitor used generally in an ICU. A test **1407** is made to determine the option of where the computations and user interface are made, that is whether they are made on the network server **1408** or otherwise. If a network server **1408** is used, all or part of the data collection and computation may be performed on this computer server **1408**. An option **1409** is provided for running a real time representation versus a representation delayed or replayed from events that previously occurred. For real time operation, a data buffer **1410** is provided to cache the data so that the representation is played in real time. For the replay of previous events, a data file **1411** provides the means for permanently storing the data so that visualization is replayed. The visualization software **1412** runs on a personal computer and can display on its monitor or on remote displays via the internet or other networking mechanism. Typically the physiological data measured on either a real patient or the simulator are fed to the personal computer from the traditional data monitor. A standard interface such as RS232, the Internet, or via a server, which receives data from the monitor, may serve as the communication channel to the personal computer running the visualization software **1412**. This program **1412** is the heart of the invention. The program **1412** computes the representation and processes the user interface. An option **1413** is provided for computing and user interface on the local desktop personal computer or for distribution across the Internet or other network mechanism. If a local desktop personal computer is selected, the personal computer **1414** with an adequate display for computation of the visualization and user interface is provided. If a remote user interface **1415** is selected the display and user interface is communicated across the Internet.

FIG. 15 is a software flow chart showing the logic steps of a preferred embodiment of the invention. The preferred embodiment of this invention begins by reading the startup file **1501**, which contains the name of the window and the properties associated with the invention. The properties associated with the a window include formulas to set object properties, text that is to be rendered in the scene, the initial size of the window, the initial rotation in each window, zoom, lighting and patient data that describes the normal state of each

variable. Internal data tables are next initialized **1502**. For each new window encountered in the startup file a new window object is made and this window object is appended to the list of windows. The window object contains an uninitialized list of properties describing the state of the window, which is filled with data from the startup file. The event loop is entered **1503**. This is a window system dependent infinite loop from which the program does not exit. After some initialization, the program waits for user input and then acts on this input. The program then takes control of the event loop for continuous rendering that is if there is no interactivity in the program. Initialization **1504** of windows is next performed. This involves calls to the window system dependent functions (these are functions that are usually different on different computational platforms) that creates the windows and displays them on the computer screen. In the current preferred embodiment of the invention, OpenGL is required, although alternative embodiments using other 3D application programming interfaces, such as PEX or DirectX, could be substituted without departing from the concept of this invention. Also, in the preferred embodiment of this invention, a personal computer graphics card is preferred in the personal computer so as to permit smooth animation with multiple windows. Although the lack of such a card is not absolutely required for operation of this invention. New data is received **1509**, typically from the data file **1506** or the data buffer **1507**. This new data **1509** can come from any source that generates floating-point numbers. The preferred line of data is composed of columns of floating point numbers separated by space. At this point the current time is also stored so that the next line of data can be obtained at the next user defined time interval, which is typically set at about 1 second. Object properties are next computed **1510**. This is performed by using formulas that are specified in the startup file to compute properties of objects. Data fields in the formulas are specified by writing the column number preceded by a dollar sign. For example, \$1/20.0 would divide the first field by 20.0. The specific properties in this application are: cardiac object dimensions, material properties, and position. Material properties can include the red, green, and blue components as they appear under ambient, diffuse, and specular light, as well as transparency. The cardiac object position includes the y and z positions as well as an x shift. If four or more lines of data have been acquired, the respiratory object properties are computed. A delay is necessary because a cubic spline is fitted, using four data points to do the fit, to the data points to generate a smooth respiratory object. Therefore, until four time steps have passed, the curtain is not rendered. Thereafter, it is rendered every time new data is acquired. Cardiac object properties include material properties and the height of the color bands. Blood pressure object length and materials are the thin cylinders that go through the top and bottom of each ellipsoid. Next, reference grid properties are computed. All objects, except the cardiac object reference are stationary, in the current implementation. The cardiac object reference can move according to the movement of the cardiac object if the user specifies this movement in the startup file. Next, sounds are computed **1511** and made audible **1513**. Objects and reference grids are rendered **1512**. Before rotation the newest object appears at the right side of the screen and oldest object is at the left side of the screen. Sound is produced **1513** next. A test **1514** is next made to determine if smooth animation is selected. If smooth animation is selected the scene will scroll during the time the program is waiting to get new data. The program, using available computing resources, selects the minimum time increment so that the shift of the objects can be rendered within the increment, but limiting the increment to

the smallest increment that human eyes can detect. If smooth animation is not selected, objects are shifted to the left **1515** such that the distance from the center of the newest cardiac object to that of the former cardiac object is equal to the inter-cardiac spacing. The process waits **1508** until the current time minus the time since data was last obtained equals the data acquisition period specified by the user. If the current time minus the time when the data was last acquired equals the user specified data acquisition period then a new line of data is acquired. If smooth animation is selected, then the cardiac objects are shifted to the left by computing **1516** to that when it is time to get the next line of data, the cardiac objects have moved **1517**, **1518** such that the distance from the rightmost cardiac object to the position where the new cardiac object will appear is equal to the inter-cardiac-object distance. For example, if it takes 0.20 seconds to render the previous scene, the period of data acquisition is 1.0 seconds, and the x shift of the rightmost cardiac object is 0.1 units then the program will shift the scene left  $(0.20/(1.0+0.20))*(1.0-0.1)=0.15$ . The formula in the denominator is  $(1.0+0.20)$  instead of 0.8 because, if the scene has been shifted left such that, when new data is acquired, the shifting has stopped (because the position of the cardiac objects satisfies the criteria that the distance from the center of the rightmost cardiac object to the center point where the new cardiac object will be rendered=1 unit) then the animation will no longer be smooth, that is, when new data is acquired the animation will appear to stop. Note, that the respiratory object is never entirely smoothly shifted because no data is available to render the object at the intermediate time steps.

FIG. **16** is a software block diagram showing the logic steps of the image computation and rendering process of a preferred embodiment of the invention. This process begins with acquiring the window identification **1601** of the current rendering context. Next, the data structure is found **1602** corresponding to the current window identification. After which, the view is set **1603**. A rotation matrix is set **1604**. A projection matrix is set **1605**. Lights are set **1606**. The back buffer is cleared **1607**. Object processing **1608** begins, and includes for each cardiac object, calling OpenGL to see material properties; shift left one inter-cardiac-object distance; push the modelview matrix, shift x,y, and z directions; call OpenGL utility toolkit to render the cardiac object; set the top cardiac object material properties, call OpenGL quadrics function to render top cardiac object; set top cardiac object material properties, call OpenGL quadrics function to render bottom cardiac object and pop modelview matrix. Next, the view is set **1609**, as above. The respiratory object is rendered **1610**, by setting OpenGL to render quad strips, for each polygon strip set material properties, and send vertex to OpenGL. Reference grids are rendered **1611** by setting material property of the cardiac reference grid. The current position is set **1612** to be the ideal position of the newest cardiac object, that is the position corresponding to a patient in ideal health. The cardiac object material properties are set **1613**. The OpenGL utility toolkit is called to render **1614** the cardiac object. Next, OpenGL is set to render quads **1615**. After which the material properties of the reference planes are set **1616**. Vertices that compose the reference planes through the OpenGL pipeline are sent **1617** and buffers are swapped **1618**. Buffer swap is a window system defendant function.

FIG. **17** is a photograph of the 3-dimensional display of a preferred embodiment of the invention. The 3-D view shown at lower right **1706** provides a comprehensive, integrated and interactive view of all physiological data, and shows the interaction between the different objects in relation to the reference frame. This view can be manipulated by the user to fit

specific application needs. The front **1701**, side **1704**, **1705** and top views **1702** show how the same data appears from different vantage points. In this figure these views **1701**, **1702**, **1704**, **1705** show the interaction between the cardiac object, the reference frame and the respiratory object, with the side view **1704** providing a target for optimum efficiency of the cardiac system **1705** shows the level of gas concentration in the lungs and overall tidal volume in the respiratory system. This FIG. **17** is a representation of a true 3-D model of the physiologic data. The circle **1703** shown is the top view of the respiratory waveform showing CO<sub>2</sub> content in the lungs and inspiration and expiration values. In **1703**, a real time display, the object grows and shrinks with each heartbeat. Its height is proportional to the heart's volume output and its width is proportional to heart rate. The gridframe (or reference framework) shows the expected normal values for stroke volume and heart rate. The position of this object in the vertical direction of the display is proportional to the patient's mean blood pressure. This graphic objects shape and animation provides a useful graphical similarity to a working heart. In the preferred embodiment, the background is colored to show inspired and expired gases. The height of the "curtain" is proportional to tidal volume, while the width is proportional to respiratory rate. The colors, which are, displayed in the preferred display show the concentrations of respiratory gases. Time is set to move from right to left, with the present or current conditions shown at the "front" or right edge of each view. Past states remain to provide a historical view of the data.

FIG. **18** is a close-up front view of the cardiac object and the associated reference framework of a preferred embodiment of the invention. The upper limit of normal blood pressure value is shown **1800** on the reference frame. The systolic blood pressure level is indicated by the bar **1801** penetrating the cardiac sphere **1806**. The height **1802** of the sphere **1806** is proportional to cardiac output, which shows the optimum efficiency of the heart. The width of the sphere **1806** is proportional to 1/heart rate. The elevation of the sphere **1806** is an indication of mean blood pressure, where the center reference gridline is a normal mean blood pressure **1803**. The lower limit, or diastolic blood pressure **1804** is shown by the length of the bar extending downward from the sphere **1806**. Previous historical values for the sphere **1806** are also provided in **1805**, **1807**.

FIG. **19** is a view of the front view portion of the display of a preferred embodiment of the present invention showing the cardiac object in the foreground and the respiratory object in the background. This view **1900** provides a more quantitative image of the hemodynamic variables, stroke volume, blood pressure **1901** and heart rate. The "normal" reference lines are more apparent. In the preferred embodiment, respiration is shown by changes in the background color.

FIG. **20** is a view of the top view portion of the display **2000** of a preferred embodiment of the present invention showing the cardiac object toward the bottom of the view and the respiratory object toward the top of the view. Inhaled gas **2002** and exhaled gas **2003**. CO<sub>2</sub> concentrations and oxygen saturation of the arterial blood **2001** versus time are also shown.

FIG. **21** is a view of the side view portion of the display of a preferred embodiment of the present invention showing the cardiac object to the left and the respiratory object to the right. Gas concentration in the lungs **2101**, a calibrated scale for gas concentration **2103**, blood pressure **2100**, and oxygen saturation **2101** are shown. The end view, shown here in FIG. **21**, is especially useful during treatment, where the goal is to bring the variables back to the center or normal state. Func-

tional relationships can be added to this view to predict how treatment can be expected to bring the variables back to normal.

FIG. 22 is a view of the 3-D perspective view portion of the display of a preferred embodiment of the present invention showing the cardiac object in the left foreground and the respiratory object in the right background. This view 2200 provides a comprehensive, integrated and interactive view of nine physiological variables. The sphere 2201 grows and shrinks with each heartbeat. Its height is proportional to the heart's stroke volume and its width is proportional to heart rate. This graphic object 2201 offers useful similarity to a beating heart. The gridframe 2202 shows the expected normal values for stroke volume and heart rate. The position of this object 2201 on the screen is proportional to the patient's mean blood pressure. The ends of the bar 2203 drawn vertically through the center of the heart object show systolic and diastolic blood pressure. In the preferred embodiment of the invention, the background 2204 is colored to show inspired and expired gases. The height of the "curtain" 2205 is proportional to tidal volume. The width of each fold 2206 is proportional to respiratory rate. In the preferred embodiment colors are used to show the concentrations of respiratory gases. Time moves from right to left with the present condition shown at the "front" or right edge of the view 2200. Past states 2207 remain to permit a historical view of the data.

FIG. 23a shows the preferred graphic element of this invention depicting a normal cardiovascular system. This graphic element 2300 is composed of a number of distinct objects 2301, 2301, 2303, 2304, 2305, 2306. Normal, or expected object represented values are shown by the filling of an object in its designated frame 2301, 2301a, 2303a, 2304a, 2305a, 2306a. Numeric values 2307a-e are also shown to provide numeric indications of the desired graphic object. Although shown here as black objects within a white frame, in alternative embodiments the objects and frames may be any desired displayable color, texture, shading and the like.

FIG. 23b shows the preferred graphic element of this invention depicting a cardiovascular system exhibiting anaphylaxis. This figure demonstrates the display of objects 2308, 2309, 2312 having values substantially less than desired or expected, by failing to fill the expected frame 2308a, 2309a, 2312a. An object 2313 having a value much larger than desired or expected is shown by overfilling its frame 2313a. Objects 2310, 2311 having expected values is shown by filling their respective frames 2310a, 2311a. Two sloped regions 2314, 2315 are provided to show a change in value between two objects.

FIG. 23c shows the preferred graphic element of this invention depicting a cardiovascular system exhibiting hypovolemia. This figure demonstrates the display of objects 2316, 2317, 2318, 2319, 2320, 2321 having values substantially less than desired or expected, by failing to fill the expected frame 2316a, 2317a, 2318a, 2319a, 2320a, 2321a. Three sloped regions 2322, 2323, 2324 are provided to show a change in value between two objects.

FIG. 23d shows the preferred graphic element of this invention depicting a cardiovascular system exhibiting bradycardia. This figure demonstrates the display of objects 2329, 2330 having values substantially less than desired or expected, by failing to fill the expected frame 2329a, 2330a. Objects 2326, 2327 having a value much larger than desired or expected is shown by overfilling its frame 2326a, 2327a. And an object 2325 having an expected value is shown by filling its respective frame 2325a. Three sloped regions 2331, 2332, 2333 are provided to show a change in value between two objects.

FIG. 23e shows the preferred graphic element of this invention depicting a cardiovascular system exhibiting ischemia. This figure demonstrates the display of objects 2338, 2339 having values substantially less than desired or expected, by failing to fill the expected frame 2338a, 2339a. An object 2336 having a value much larger than desired or expected is shown by overfilling its frame 2336a. Objects 2334, 2335 having expected values is shown by filling their respective frames 2334a, 2335a. Two sloped regions 2340, 2341 are provided to show a change in value between two objects.

FIG. 23f shows the preferred graphic element of this invention depicting a cardiovascular system exhibiting pulmonary embolism. This figure demonstrates the display of objects 2343, 2344, 2345, 2346, 2347 having values substantially less than desired or expected, by failing to fill the expected frame 2343a, 2344a, 2345a, 2346a, 2347a. An object 2342 having a value much larger than desired or expected is shown by overfilling its frame 2342a. Two sloped regions 2348, 2349 are provided to show a change in value between two objects.

FIG. 24 shows the preferred reference grid of this embodiment of this invention. A reference grid 2400 is provided within which space is allocated for graphic objects 2401, 2402, 2403, 2404.

FIG. 25 shows the preferred reference grid 2400 of this embodiment of this invention with the preferred object placement 2501, 2502, 2503, 2504 as well as a center line axis point 2500 indicated. Generally the center line axis 2500 is used to scale the object from a center point. Smaller objects, such as 2502, indicates lower values. While larger objects, such as 2503, indicates larger values.

FIG. 26 shows the preferred reference frame 2400 of this embodiment of this invention with the preferred object relationships indicated. This figure provides the placement of objects identified with specific physical processes. For example, object 2601 is CVP, object 2602 is PAP, object 2603 is LAP, object 2604 is HR SV and object 2605 is MAP. In alternative applications of this invention, different physical processes can be assigned to the objects.

FIG. 27 shows a representative three-dimensional object 2700 used in the present preferred embodiment of this invention. This preferred object 2700 is generally cylindrical in shape placed in a three-dimensional coordinate system 2701. Alternative object shapes are foreseeable and can be substituted without departing from the concept of this invention.

FIG. 28 shows a representative view of the normalization of the present preferred embodiment of this invention. This figure shows the normalization of frames 2801a-e set within a reference grid 2800.

FIG. 29 shows and integrated view presenting numeric information 2901 in the present preferred embodiment of this invention set to associate with particular objects 2902a-d within a reference frame 2900.

FIG. 30 shows the addition of slope features 3004, 3005 to show the restriction of blood flow, designated in objects 3001, 3002, 3003, within a reference frame 3000.

In one embodiment of the invention, a pulmonary metaphor was developed to improve the anesthesiologist's situational awareness. The metaphor displays the patient's physiological status in an intuitive and meaningful way by depicting metaphor signatures representing critical pulmonary variables and events. Pulmonary variables include tidal volume, respiratory rate, fractional inspired oxygen, peak end expiratory pressure, oxygen saturation in arterial blood, oxygen partial pressure in arterial blood, carbon dioxide partial pressure in arterial blood, oxygen partial pressure in alveoli, carbon dioxide partial pressure in alveoli, end tidal carbon dioxide, functional residual capacity, acidity of blood, peak

inspiratory pressure, dead space, compliance, airway resistance, ventilation/perfusion, shunting of blood, and alveoli/arterial oxygen gradient. Pulmonary events include hypoventilation, hyperventilation, COPD, intrinsic PEEP, ventilator off, stiff lung, pneumothorax, bronchospasm, obstructed ETT, esophageal intubation, hypoxemia, endobronchial intubation, and hypercarbia.

FIG. 31 shows a an embodiment of a pulmonary metaphor 3100 that anatomically represents the bellows 3101, airway 3102, lungs 3103, inspired gas 3104, and expired gas 3105. In one embodiment the bellows 3101 was chosen to be a gray/blue color similar to the bellows in a ventilator. The bellows 3101 move along the y-axis 3106 representing tidal volume. The bellows 3101 bulges along the x-axis 3107 representing Peak Inspiratory Pressure (PIP). The airway 3102 was chosen to be silver, and changes along the x-axis 3107 respective to airway resistance. An obstructed airway would be depicted as a rounded narrowing of the tube. The lung 3103 could also be considered the alveoli or site of gas exchange interchangeably. The shade of green may be used to map the FO<sub>2</sub> present in the alveoli 3103. The black line 3108 surrounding the lung 3103 is mapped inversely to compliance. The thicker the line; the lower the compliance; the stiffer the lung. The width of the lung 3103 is mapped to intrinsic Peak End Expiratory Pressure (PEEP). As the intrinsic PEEP increases, the lung 3103 bulges out on its sides depicting a high internal pressure as shown in FIG. 33. Inhaled/inspired gas 3104 may be green in color and is mapped to fractional inspired oxygen (FIO<sub>2</sub>). Green is a common color used on physiological monitors for oxygen. Exhaled/expired gas 3105 may be colored gray and is mapped to end tidal carbon dioxide (ETCO<sub>2</sub>). Gray is a common color used on physiological monitors for carbon dioxide. A reference frame 3109, 3110, 3111, 3112, 3113, surrounds each individual feature. An abnormal value change is depicted in the positive or negative direction from the reference frame 3109, 3110, 3111, 3112, 3113. Subsequently, the abnormal emerging features will appear to pop out and the metaphor will no longer look symmetrical.

FIG. 32 shows an embodiment of a pulmonary metaphor where various features are abnormal. The reference frames of each feature 3201, 3202, 3203, 3204, 3205 are outlined in black. The bellows 3206 have compressed, the airway 3207 has constricted, and expired gas 3208 has increased.

FIG. 33 shows an embodiment of a pulmonary metaphor where the intrinsic PEEP has increased. This has caused the lung 3301 to bulge out on its sides bond the normal reference frame 3302 to depict a high internal pressure. Additionally, the expired gas 3303 has decreased, and the airway 3304 has constricted.

FIG. 34 shows a preferred embodiment of a pulmonary metaphor. The bellows 3401 are connected the lungs 3405 via the airway 3404. Inspired gas 3403 and expired gas 3402 are located on either side of the bellows 3401.

FIG. 35 shows an embodiment of a pulmonary metaphor wherein the patient has pulmonary fibrosis. The bellows 3501 has bulged out the sides and constricted downward. The airway 3502 shows resistance and the expired gas 3503 has increased.

FIG. 36 shows an alternative embodiment of a pulmonary metaphor wherein the patient has pulmonary fibrosis. The bellows 3601 has bulged out the sides and constricted downward. The airway 3602 shows resistance and the expired gas 3603 has increased.

FIG. 37 shows an embodiment of a pulmonary metaphor wherein the patient has emphysema. The airway 3701 is restricted and lungs 3703 are bulging and the expired gas 3702 has decreased.

FIG. 38 shows an alternative embodiment of a pulmonary metaphor wherein the patient has emphysema. The airway 3801 is restricted and lungs 3803 are bulging and the expired gas 3802 has decreased.

It is to be understood that the above-described embodiments and examples are merely illustrative of numerous and varied other embodiments and applications which may constitute applications of the principles of the invention. Such other embodiments may be readily devised by those skilled in the art without departing from the spirit or scope of this invention and it is our intent that they are deemed to be within the scope of this invention.

The invention claimed is:

1. A medical display method for using a data processor to provide an integrated representation of a patient's pulmonary system for diagnostic purposes and display to a user, comprising:

displaying an inspired gas object on a display, wherein the inspired gas object is configured to depict a patient's inspired gas volume as measured by a first sensor configured to detect inspired gas;

displaying a lung object on the display, the lung object being associated with the inspired gas object and configured to represent a patients' lung condition as sensed by a second sensor configured to detect a lung condition;

displaying an expired gas object on the display, the expired gas object being configured to represent a patient's expiration volume as measured by third sensor configured to detect expired gas, and the expiration object being displayed in combination with the lung object and inspired gas object to exhibit interaction between objects to display pulmonary states of the patient; and

displaying a normal reference frame on the display, the normal reference frame representing expected normal pulmonary values for inspired gas, lungs and expired gas.

2. A medical diagnostic display method as in claim 1, further comprising:

displaying an airway object representing a constriction state of a patient's airway;

displaying a ventilation object in communication with the airway object representing tidal volume of the patient's pulmonary system.

3. A medical diagnostic display method as in claim 2, wherein a ventilation object is configured in a symbolic lung shape.

4. A medical diagnostic display method as in claim 1, wherein the lung object represents alveoli or a site of gas interchange.

5. A medical diagnostic display method as in claim 1, further comprising displaying a lung reference frame having lung reference frame thickness mapped inversely to lung compliance, wherein a thicker lung reference frame represents increased lung stiffness.

6. A medical diagnostic display method as in claim 5, wherein the lung object is mapped to Positive End Expiratory Pressure (PEEP).

7. A medical diagnostic display method as in claim 5, wherein the lung object can expand in width past the lung reference frame to represent high internal lung pressure or volume.

8. A medical diagnostic display method as in claim 1, wherein changes on an x-axis of the airway object represent Positive Inspiratory Pressure (PIP).

9. A medical diagnostic display method as in claim 1, wherein the inspired gas object is configured to represent fractional inspired oxygen concentration (FIO<sub>2</sub>).

10. A medical diagnostic display method as in claim 1, wherein the expired gas object is configured to represent end tidal carbon dioxide concentration (ETCO<sub>2</sub>).

11. A medical diagnostic display method as in claim 1, wherein the normal reference frame and object within the reference frame are configured to show positive increases past normalization by expanding outside the reference frame and negative decreases from normalization by shrinking within the reference frame.

12. A medical diagnostic display method for using a data processor to provide an integrated view of a patient's pulmonary system for display to a user, comprising:

displaying an inspired gas object configured to depict a patient's inspired gas volume as measured by a first sensor configured to detect inspired gas;

displaying a lung object associated with the inspired gas object, the lung object configured to represent a patient's lung status as sensed by a second sensor configured to detect a lung status;

displaying an expired gas object configured to display a patient's respiration volume as measured by a third sensor configured to detect expired gas, the expiration object being associated with the lung object;

displaying an airway object extending from the lung object and representing a constriction state of a patient's airway as sensed by a fourth sensor configured to detect airway constriction;

displaying a ventilation object coupled to the airway object, the ventilation object representing tidal volume of the patient's pulmonary system, wherein the tidal volume of the patient's pulmonary system is sensed using a fifth sensor configured to detect pulmonary system tidal volume, and wherein pulmonary objects are displayed in combination to exhibit interaction between objects to display pulmonary states of the patient; and displaying a normal reference frame surrounding each of the pulmonary objects, wherein the normal reference frame represents expected normal pulmonary values.

13. A medical diagnostic display method as in claim 12, wherein the inspired gas object, lung object, expired gas object, airway object, and ventilation object are organized in

a order that represents the pulmonary system as compared to timing of the pulmonary processes.

14. A medical diagnostic display method as in claim 12, wherein each pulmonary object can expand past the normal reference frame or contract within the normal reference frame to show an abnormal pulmonary state.

15. A method for displaying diagnostic patient pulmonary data in a three-dimensional display on a display screen, comprising the steps of:

measuring a patient's inspired gas volume using a first sensor configured to detect inspired gas volume and representing the inspired gas volume as an inspired gas object;

displaying a lung object associated with the inspired gas object, the lung object being configured to represent a patient's lung condition as sensed by a second sensor configured to detect a lung condition;

displaying an expired gas object configured to display the patient's respiration volume as measured by a third sensor configured to detect respiration, wherein the expired gas object is associated with the lung object;

representing a constriction state of an airway using an airway object extending from the lung object, wherein the constriction state of the airway is sensed using a fourth sensor configured to detect airway constriction;

representing tidal volume of a patient's pulmonary system using a ventilation object coupled to the airway object, wherein the tidal volume of the patient's pulmonary system is sensed using a fifth sensor configured to detect pulmonary system tidal volume, and wherein pulmonary objects are displayed in combination to exhibit interaction between objects to display pulmonary states of the patient; and

providing a normalization frame surrounding each of the pulmonary objects, wherein the normal reference frame represents expected normal pulmonary values.

16. A method as in claim 15, wherein each pulmonary object can expand past the reference frame or contract within the reference frame to show an abnormal pulmonary state.

\* \* \* \* \*

UNITED STATES PATENT AND TRADEMARK OFFICE  
**CERTIFICATE OF CORRECTION**

PATENT NO. : 7,654,966 B2  
APPLICATION NO. : 10/269423  
DATED : February 2, 2010  
INVENTOR(S) : Westenkow et al.

Page 1 of 1

It is certified that error appears in the above-identified patent and that said Letters Patent is hereby corrected as shown below:

On the Title Page:

The first or sole Notice should read --

Subject to any disclaimer, the term of this patent is extended or adjusted under 35 U.S.C. 154(b) by 2156 days.

Signed and Sealed this

Twenty-third Day of November, 2010

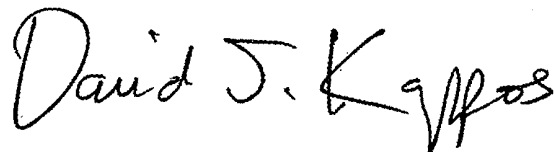
A handwritten signature in black ink that reads "David J. Kappos". The signature is written in a cursive, flowing style.

David J. Kappos  
*Director of the United States Patent and Trademark Office*

专利名称(译)	使用关键功能的n维表示来监测动态心血管功能的方法和装置		
公开(公告)号	<a href="#">US7654966</a>	公开(公告)日	2010-02-02
申请号	US10/269423	申请日	2002-10-11
[标]申请(专利权)人(译)	犹他大学		
申请(专利权)人(译)	犹他大学		
当前申请(专利权)人(译)	UTAH研究基金会大学		
[标]发明人	WESTINSKOW DWAYNE AGUTTER JAMES SYROID NOAH STRAYER DAVID ALBERT ROBERT WACHTER S BLAKE DREWS FRANK		
发明人	WESTINSKOW, DWAYNE AGUTTER, JAMES SYROID, NOAH STRAYER, DAVID ALBERT, ROBERT WACHTER, S. BLAKE DREWS, FRANK		
IPC分类号	A61B5/08 A61B5/00 A61B5/0205		
CPC分类号	A61B5/00 A61B5/0205 A61B5/742		
代理机构(译)	THORPE北西区LLP		
优先权	60/328880 2001-10-12 US		
其他公开文献	US20030227472A1		
外部链接	<a href="#">Espacenet</a> <a href="#">USPTO</a>		

摘要(译)

公开了一种用于监测，诊断和评估动态肺部系统的状态的方法，系统，装置和装置。该方法和系统提供用于接收感测的和/或模拟的数据，将这样的数据转换为可显示的对象格式并且以使得各个变量之间的相互关系可以由用户相关和识别的方式显示这样的对象的处理装置。本发明提供了相对于动态系统的肺临界函数的总体状态的快速认知掌握。

