



US 20070232942A1

(19) **United States**

(12) **Patent Application Publication**
Quy

(10) **Pub. No.: US 2007/0232942 A1**

(43) **Pub. Date: Oct. 4, 2007**

(54) **METHOD AND APPARATUS FOR HEALTH AND DISEASE MANAGEMENT COMBINING PATIENT DATA MONITORING WITH WIRELESS INTERNET CONNECTIVITY**

which is a continuation of application No. 09/738,270, filed on Dec. 15, 2000, now Pat. No. 6,602,191.

(60) Provisional application No. 60/172,486, filed on Dec. 17, 1999.

(76) Inventor: **Roger J. Quy**, Mill Valley, CA (US)

Correspondence Address:
MAYER & WILLIAMS PC
251 NORTH AVENUE WEST
2ND FLOOR
WESTFIELD, NJ 07090 (US)

Publication Classification

(51) **Int. Cl.**
A61B 5/02 (2006.01)
(52) **U.S. Cl.** **600/508**

(21) Appl. No.: **11/649,355**

(22) Filed: **Jan. 3, 2007**

(57) **ABSTRACT**

Related U.S. Application Data

(63) Continuation of application No. 11/156,177, filed on Jun. 17, 2005, now Pat. No. 7,156,809, which is a continuation-in-part of application No. 10/773,501, filed on Feb. 6, 2004, now Pat. No. 6,976,958, which is a continuation-in-part of application No. 10/418,845, filed on Apr. 18, 2003, now Pat. No. 6,936,007,

Embodiments of the invention provide a method and apparatus for a wireless health monitoring system for interactively monitoring a disease or health condition of a patient by connecting a mobile phone to or with a digital camera and/or a medical monitoring device. The health related data or visual information from the camera is transmitted to a server using standard internet protocols and may be integrated with various operating systems for handheld or wireless devices, especially those with enhanced capabilities for handling images and visual data.

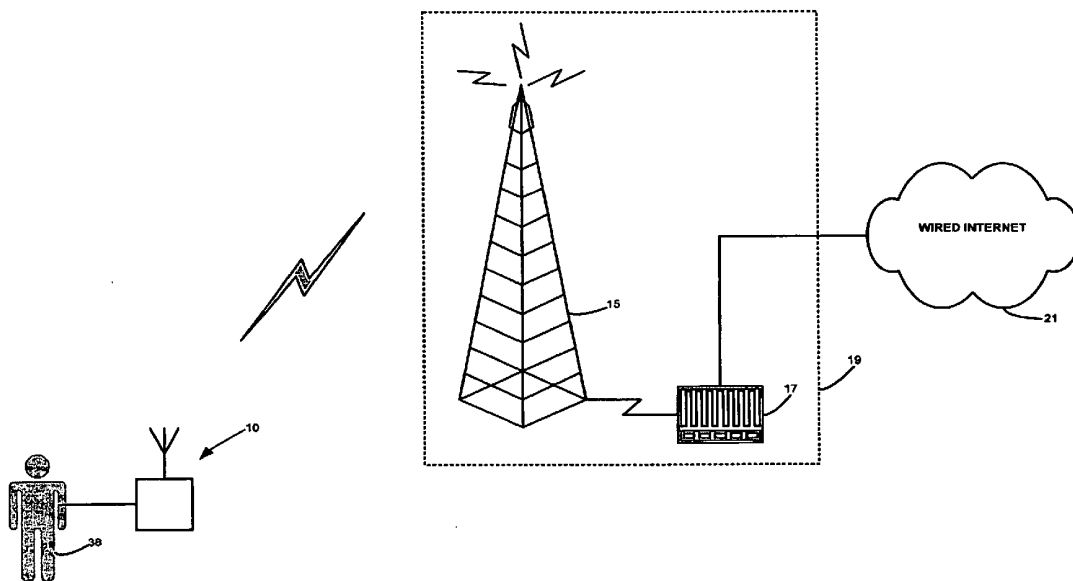

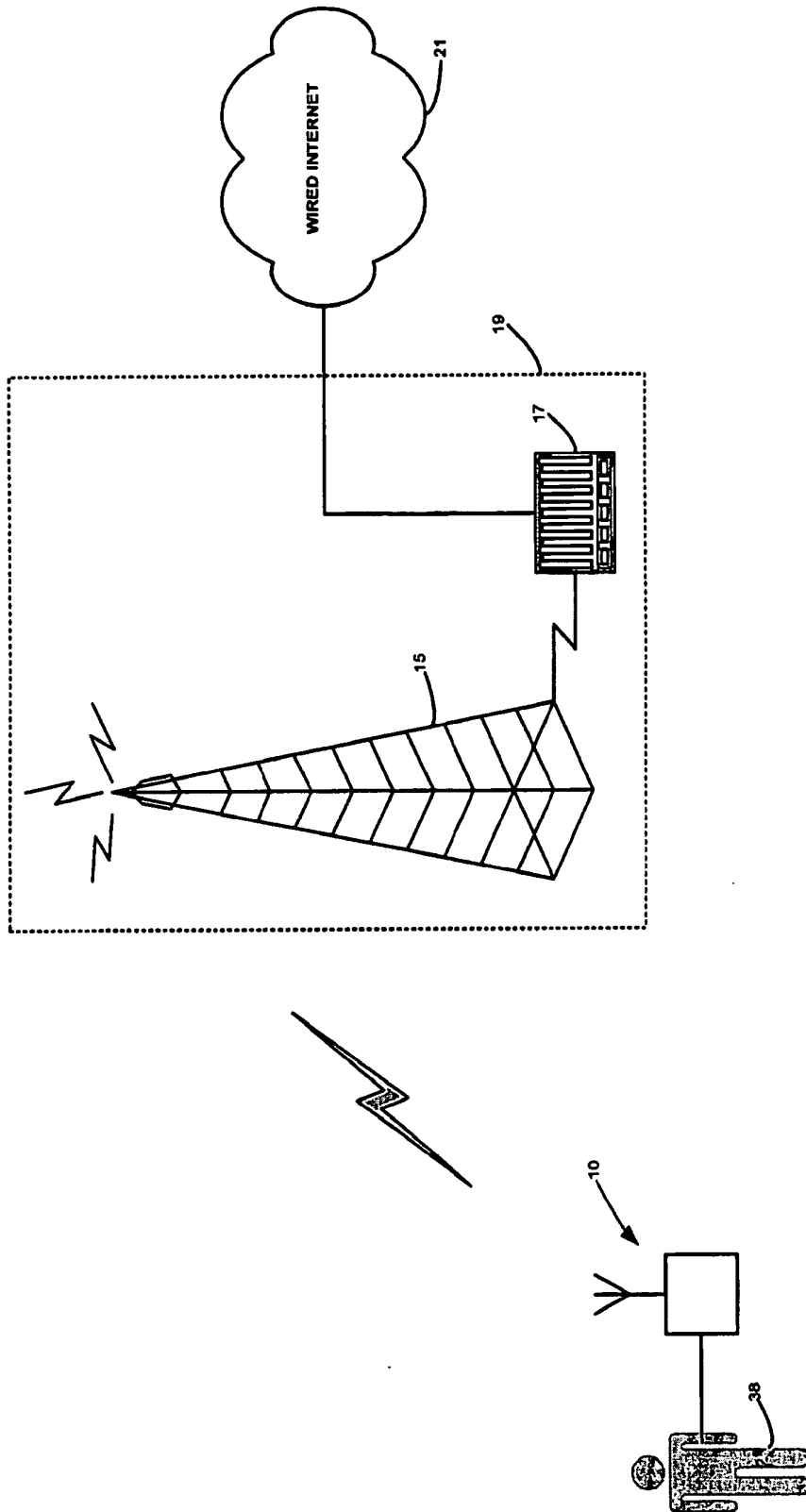

FIG. 1

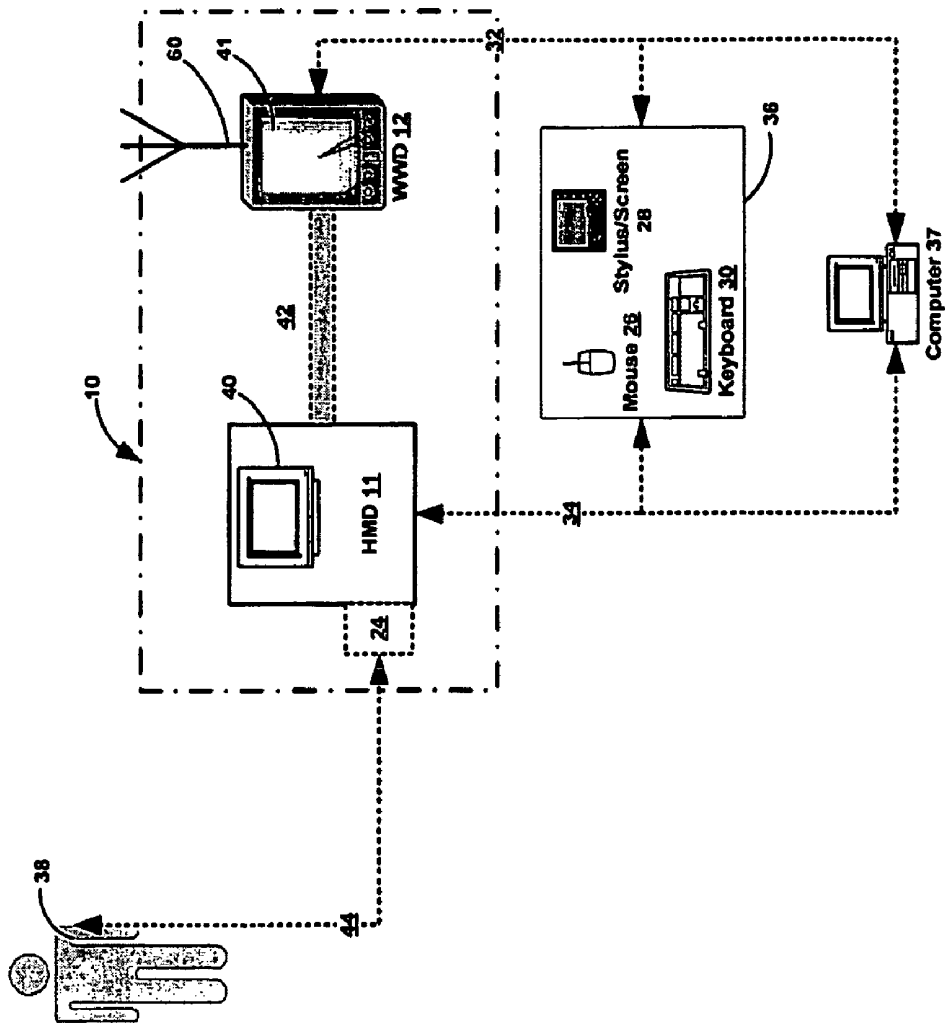
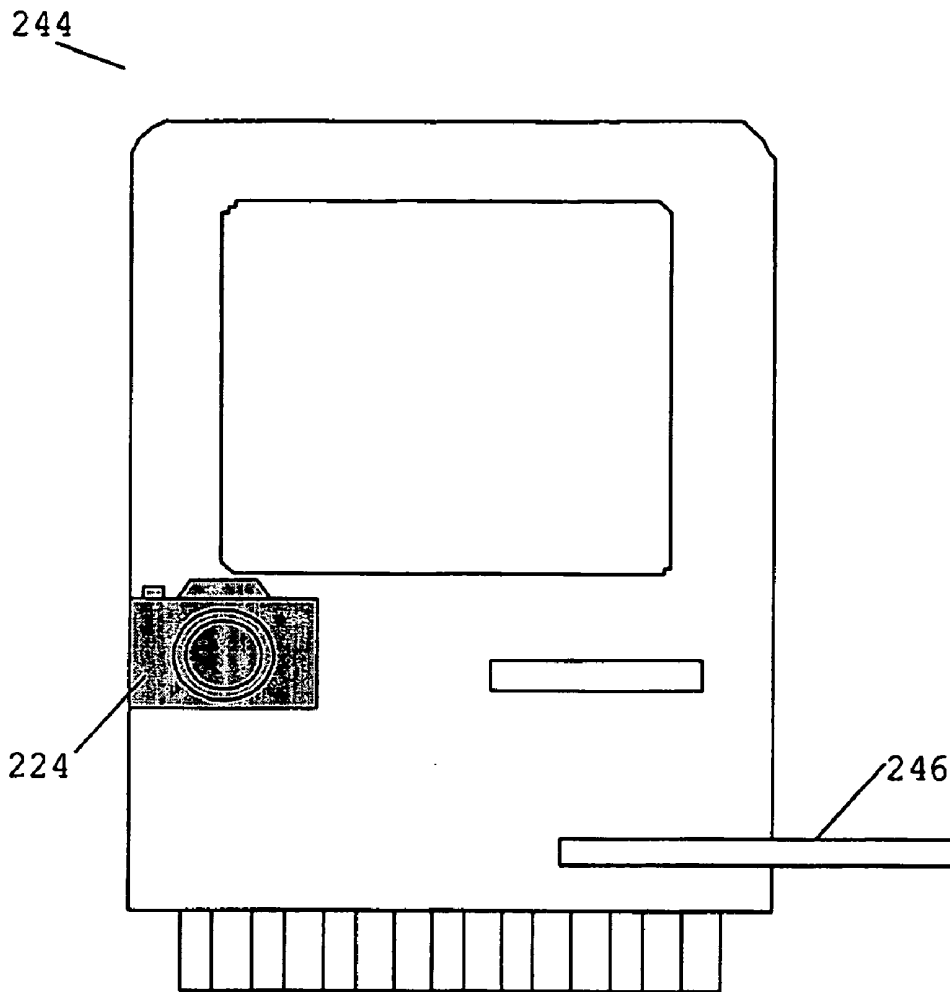

FIG. 2

FIG. 3



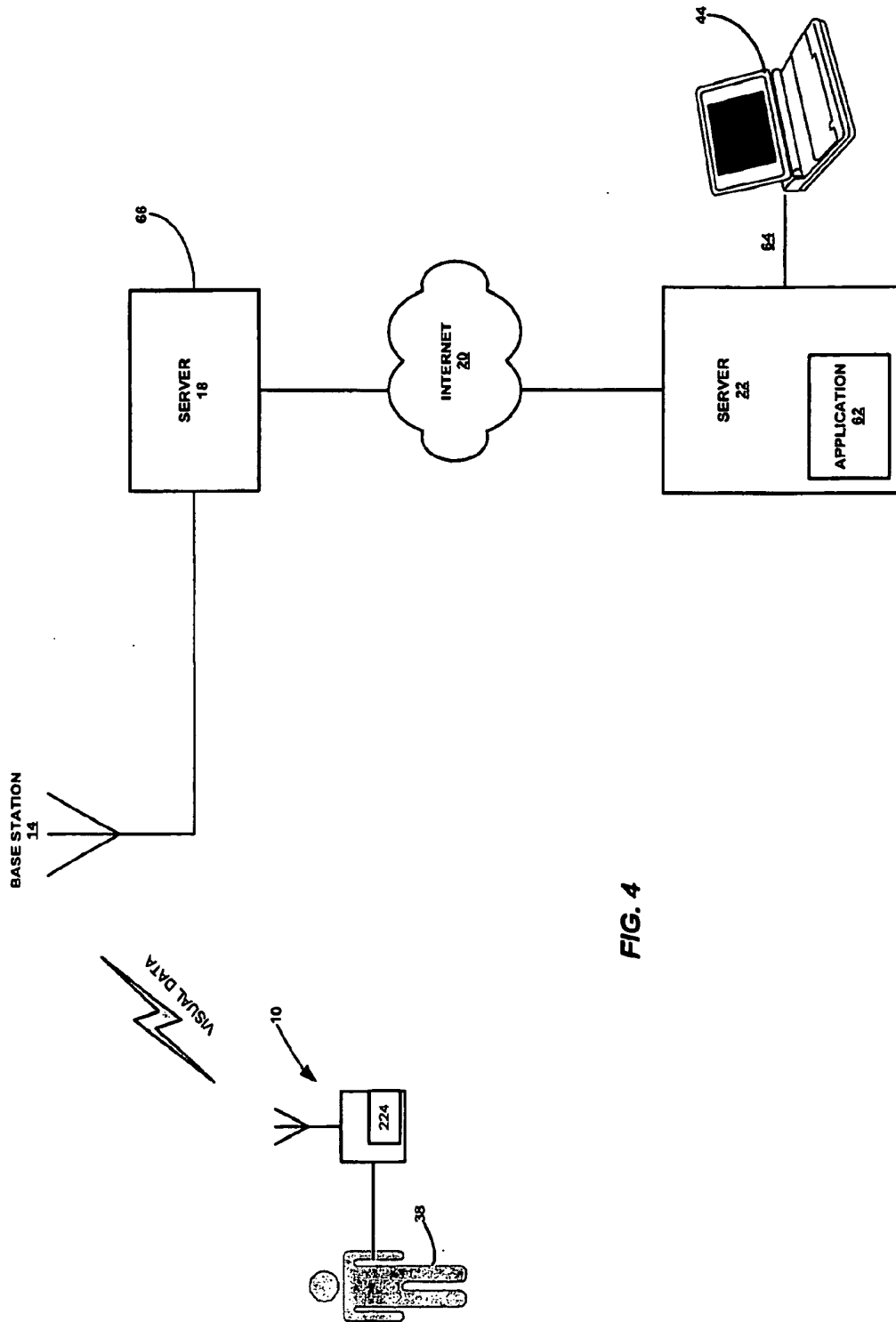

FIG. 4

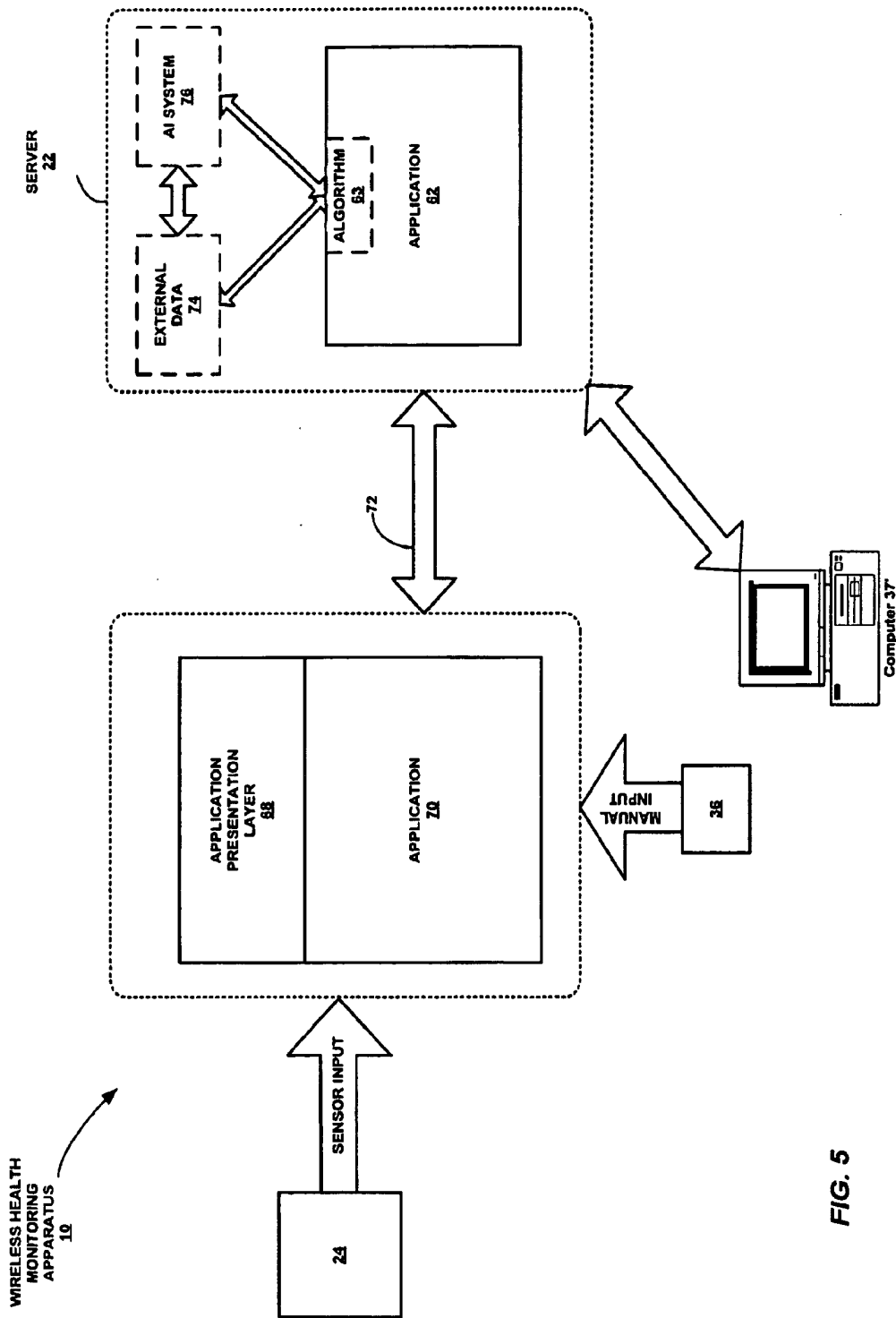
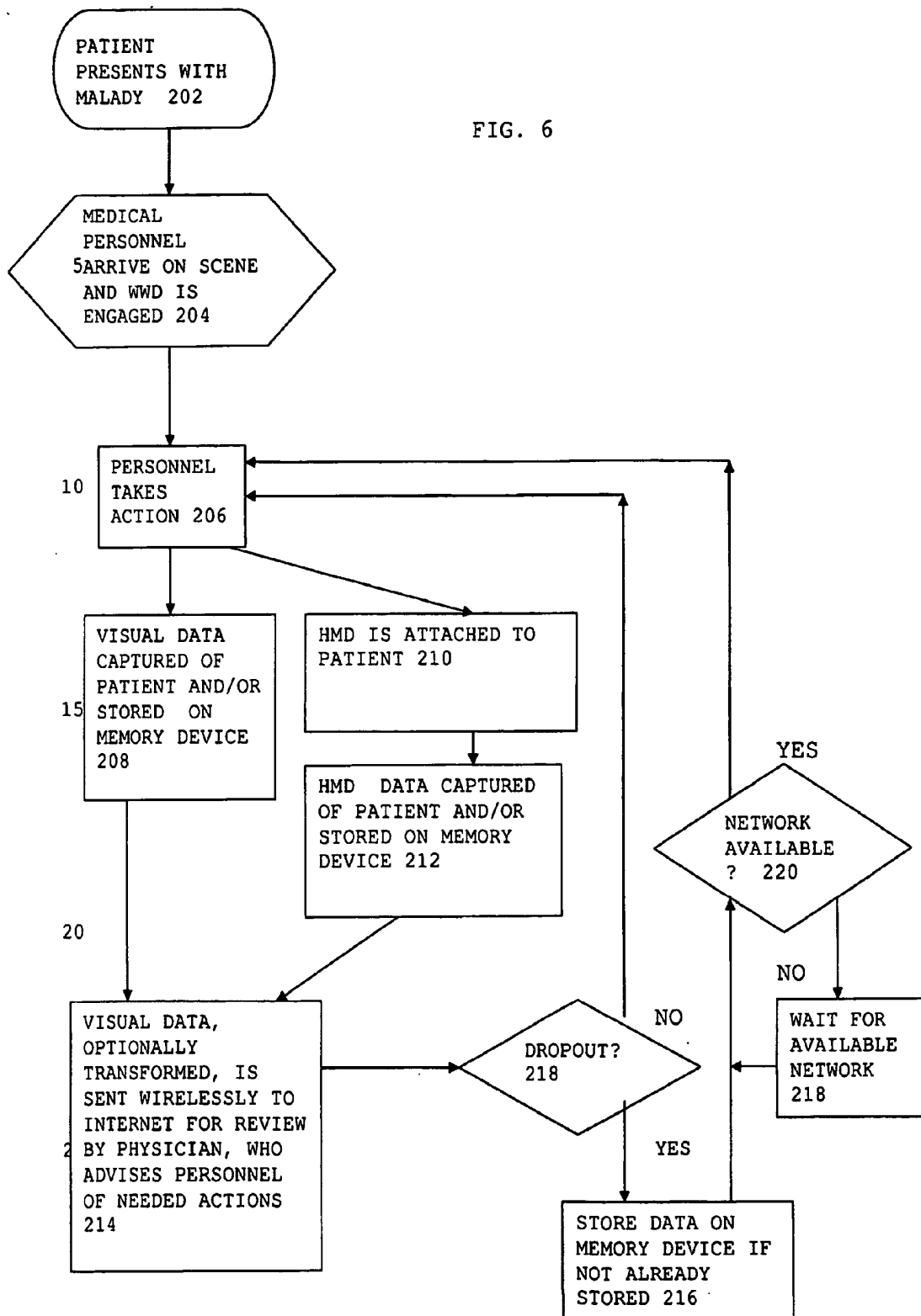

FIG. 5

FIG. 6



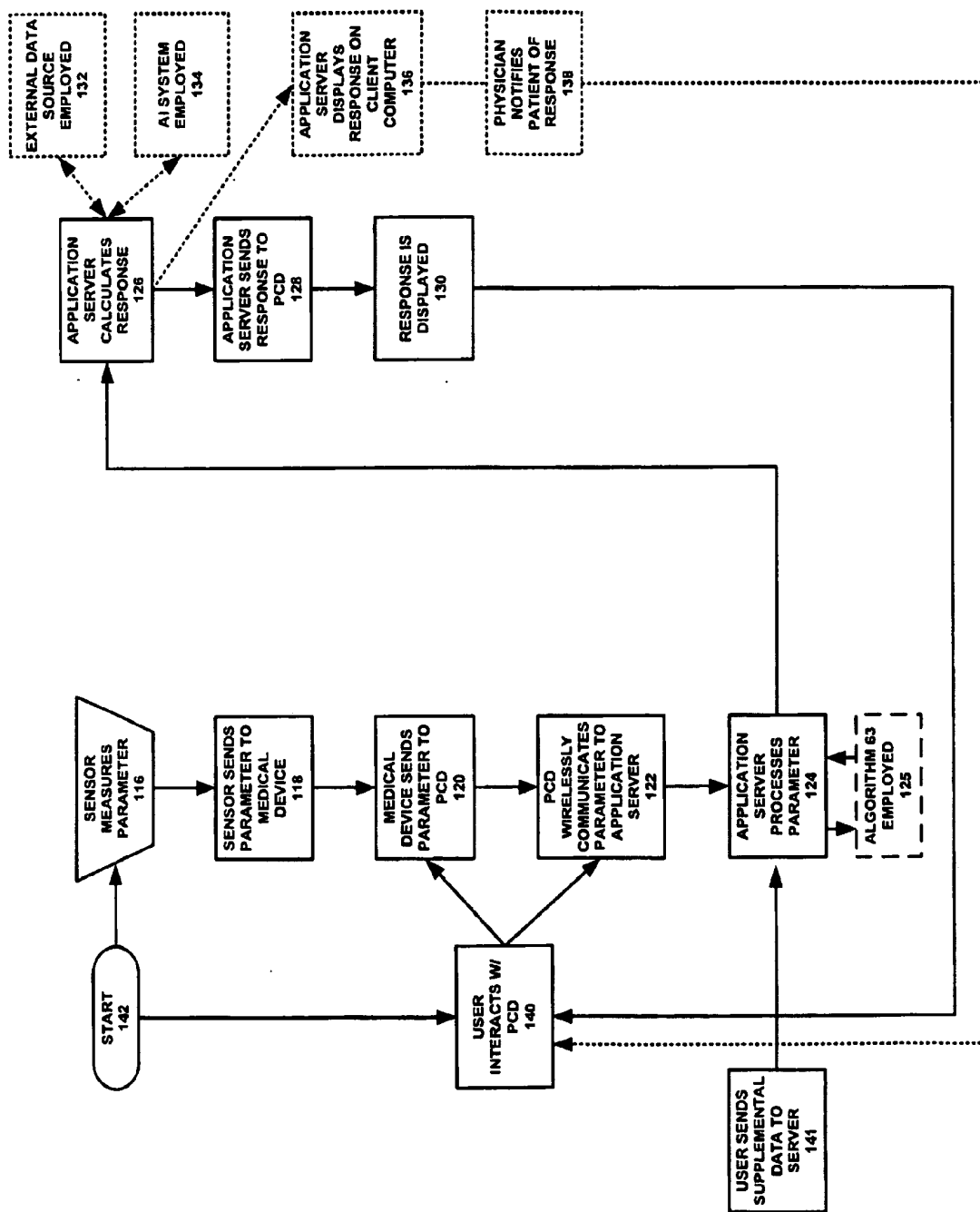

FIG. 7

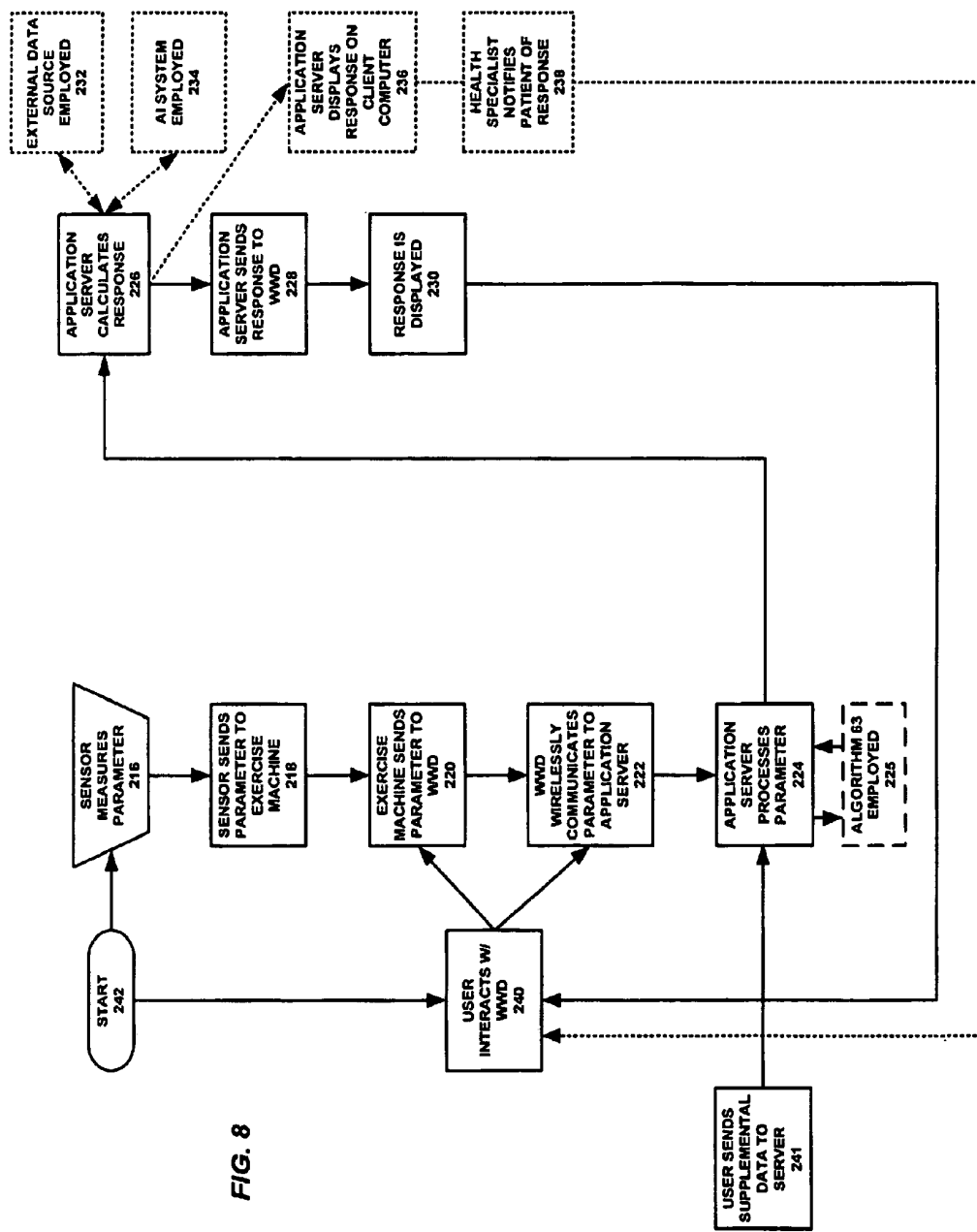

FIG. 8

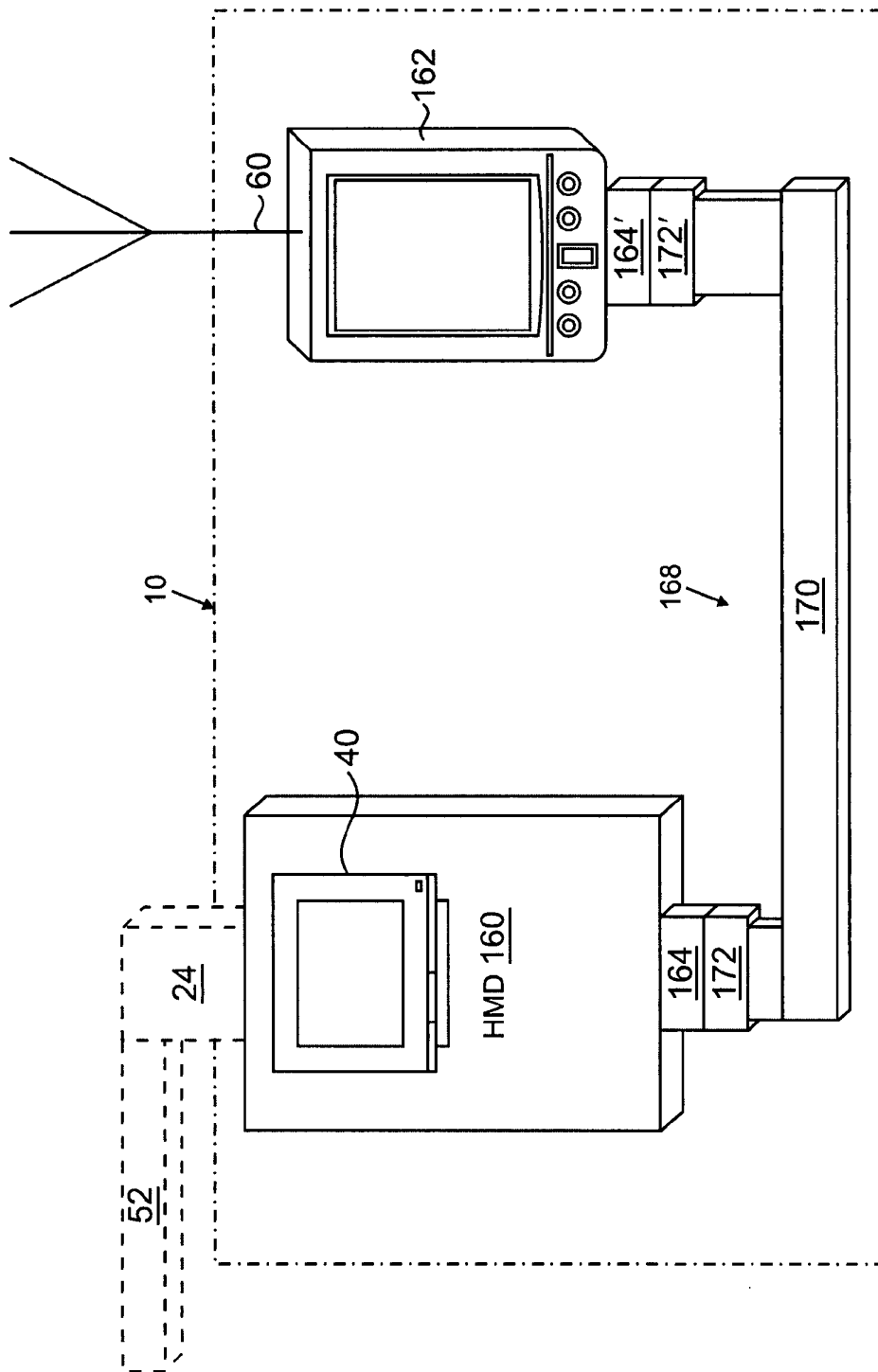

FIG. 9

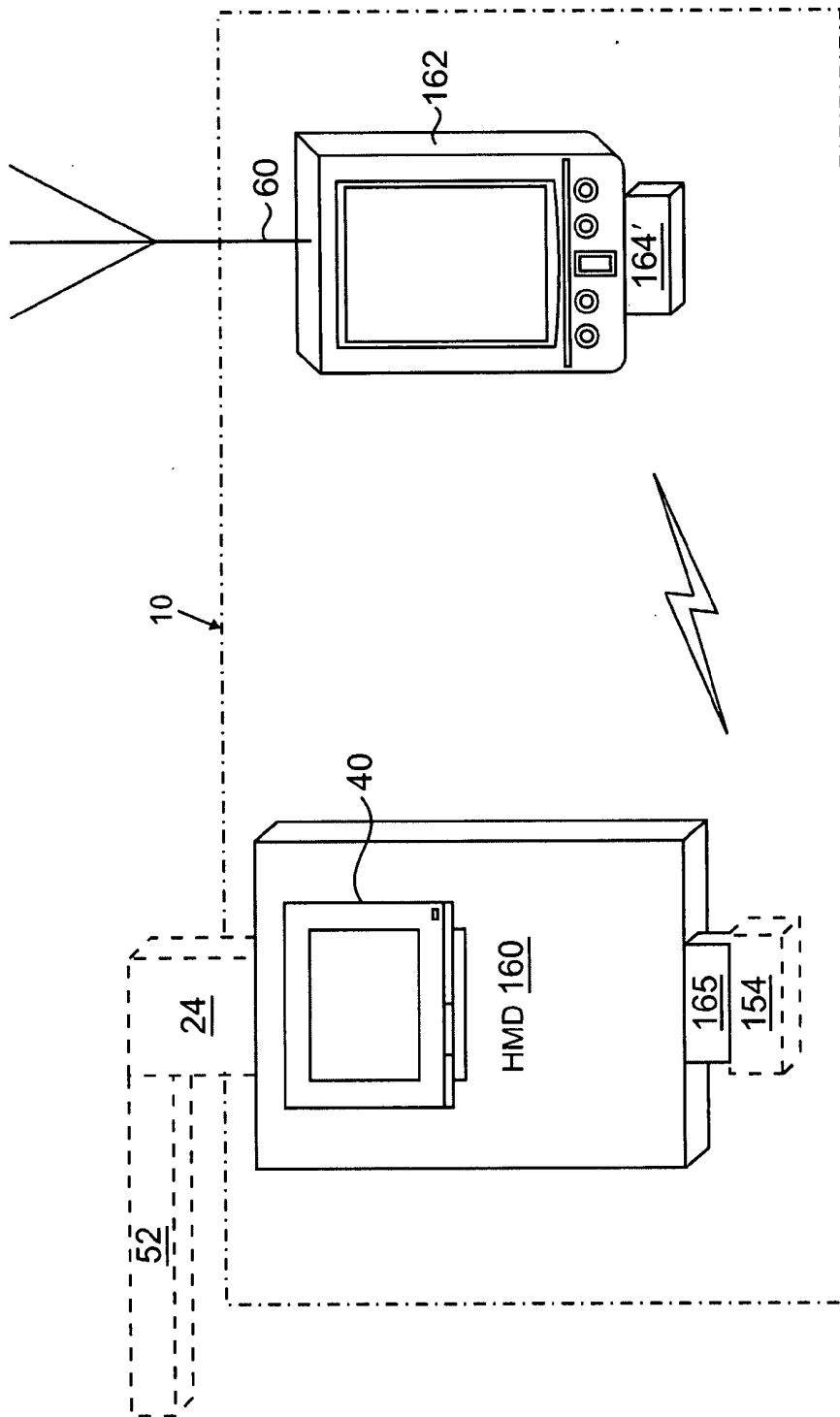

FIG. 10

METHOD AND APPARATUS FOR HEALTH AND DISEASE MANAGEMENT COMBINING PATIENT DATA MONITORING WITH WIRELESS INTERNET CONNECTIVITY

CROSS-REFERENCE TO RELATED APPLICATIONS

[0001] This application is a continuation of U.S. patent application Ser. No. 11/156,177, filed Jun. 17, 2005, entitled "Method and Apparatus For Health and Disease Management Combining Patient Data Monitoring With Wireless Internet Connectivity," now U.S. Pat. No. 7,156,809, which is a continuation-in-part of U.S. patent application Ser. No. 10/773,501, filed Feb. 6, 2004, now U.S. Pat. No. 6,976,958, which is a continuation-in-part of U.S. patent application Ser. No. 10/418,845, filed Apr. 18, 2003, now U.S. Pat. No. 6,936,007, which is a continuation of U.S. patent application Ser. No. 09/738,270, filed Dec. 15, 2000, now U.S. Pat. No. 6,602,191, which claims the benefit of U.S. Provisional Patent Application Ser. No. 60/172,486 filed Dec. 17, 1999, entitled "Method and Apparatus for Health and Disease Management Combining Patient Data Monitoring with Wireless Internet Connectivity", the entirety of each being incorporated by reference herein.

REFERENCE TO GOVERNMENTAL SUPPORT

[0002] (none)

REFERENCE TO MICROFICHE APPENDIX

[0003] (none)

FIELD OF THE INVENTION

[0004] The present invention relates to monitoring of living subjects, and more particularly to health-monitoring of persons where measured or input health data, including photographic, video or voice information, is communicated by a mobile communications device to and from a software application running on an internet-connected server and where the same may be studied and processed by the software application, a health professional, a caregiver, or the subject.

BACKGROUND OF THE INVENTION

[0005] Several attempts have been made in the past to achieve efficient interactive communication of medical or health information between a subject or patient and a reviewer or provider of that information. However, in general, previous systems have limited the user to the general location in which the device was located. For example, in U.S. Pat. No. 5,441,047, images and data were transmitted by standard telephone lines or wireless telemetry systems.

[0006] Even where devices are portable, as in the case of a laptop computer with a modem, an ordinary POTS phone line must be found and used. Where the user's computer employs a broadband connection, such as DSL or satellite, the choices of location are even more limited.

[0007] Attempts have been made to remedy this deficiency. As noted above, some telemetry systems allow a "wireless" distance to be placed between a health measuring unit and a remote monitoring system. However, such systems are limited in their range.

[0008] Other systems have used cellular telephone technology to increase the wireless health monitoring range. However, these systems have several deficiencies, such as requiring significant modification of the mobile phone. For example, U.S. Pat. No. 5,772,586, issued Jun. 30, 1998 to Heinonon et al., discloses a method for monitoring the health of a patient. This system uses a specialized connection between the patient health measuring unit and the cellular phone, however. The patient health measuring unit is located in the battery space of the mobile phone and is connected to a communication bus of the mobile phone. Other systems have been proposed, but these suffer from similar deficiencies in that they require specially modified cellular phones to be employed.

[0009] The deployment of the above systems also currently lacks employment of full back-end server functionality with which to provide a wide range of interactive communication with the patient. Instead, such systems, if internet-enabled, are often limited to mere one-way non-interactive data transfer via a modem.

SUMMARY OF THE INVENTION

[0010] Embodiments of the present invention overcome one or more of the disadvantages of the prior art by providing a full-feature health-monitoring system that may wirelessly connect to a back-end server application via the internet. The invention allows wireless access to and from a wide variety of present medical or health-related instruments and devices, while maintaining the capability of connecting to future such devices.

[0011] The advent of multimedia mobile phones and other personal communications devices that include a digital camera, or are able to connect with one, allows the capture and transmission of medical information, including images. Existing multimedia mobile phones have the capability of transmitting voice, images and data from a medical monitoring device. In addition to the uploading of images, the display screen of a WWD allows the display of images such as illustrations, diagrams or video clips which may be downloaded from a server as part of an interactive user interface (e.g., for the purpose of describing to a caregiver how to set up a medical device). The ability to include images in a system that is based on a WWD connected to a medical device helps facilitate the remote diagnosis and management of a medical condition.

[0012] The "reviewer or provider of medical or health information" is understood to include not only a physician or paramedic but also a software application or algorithm that may analyze the information. The medical information can include data from a variety of monitoring devices and images relating to the condition of the patient. The images could include photographs or videos of the patient's specific malady or general condition that aid diagnosis and treatment.

[0013] In particular, the invention may be embodied in several systems. Two complementary such systems are described herein, although extensions to other such systems can be envisioned. First, an embodiment of the invention may be employed to manage the disease state or condition of a patient. In this embodiment, the patient, or a caregiver, may employ a health monitoring device ("HMD"), in particular a medical device, and a wireless connection to

provide data from the medical device for processing via the internet, including a review by a physician or other health care professional if required.

[0014] In the second embodiment, a health or lifestyle management plan may be implemented. Various health parameters, such as those relating to nutrition or exercise, may be entered into a health monitoring device, in this instance termed an “exercise machine”, and the same may be wirelessly communicated to a server. An application may process and store the health parameters, and a health specialist may optionally review the same.

[0015] In other embodiments, the condition of patients may be evaluated by collecting medical data and providing information in response to those data by means of a WWD designed to display interactive information through a connection to the Internet. The present invention may be connected to various HMDs, and may communicate information via a wireless connection such as a wireless Internet connection. The user of the present invention may be the patient or a caregiver, such as medical or paramedic personnel.

[0016] Wireless internet connectivity has many advantages. For example, in the first embodiment, a diabetic could connect a blood glucose meter to an internet-enabled wireless web device (“WWD”) away from home and download data to a Diabetes Management Company’s server and, in response, receive guidance displayed on the screen (or by voice) about choices for the next meal.

[0017] Alternatively, in the second embodiment, a person interested in tracking an exercise program may take the WWD to the local health club and attach the same to an exercise machine, send data output from various exercise machines over the Internet, and receive a personalized response from the server of a company specializing in Health & Lifestyle Management. The individual may input caloric content of foods eaten, and may further input caloric content of exercise performed. In this way, e.g., a person in a weight-loss program may see in great detail whether they are expending more calories in the form of exercise than the same individual is consuming in the form of food.

[0018] In general, in the health management embodiment, the system may be employed to monitor the physiologic status of a healthy subject while eating, exercising, or performing other activities. For clarity, such devices are termed herein “exercise machines”. These may include an electronic body weight scale, a body fat gauge, biofeedback devices, physiotherapy or chiropractic equipment, blood pressure recorders, or the like, or any type of exercise machine or monitor, including a heart rate monitor, treadmill, rowing machine, stepper, or the like.

[0019] In more detail, the present invention provides a method and system for assisting patients to manage a medical condition or disease or maintain healthy lifestyle by collecting health-related data and providing information in response to those data by means of a WWD designed to display interactive information through a connection to the Internet. The present invention may be connected to various HMDs, both medical and exercise-related in nature, and may communicate information via a wireless connection such as a wireless Internet connection.

[0020] A major advantage of embodiments of the invention is that the same frees the patient from the constraints of

wired systems. The same allows users with consumer “off-the-shelf” wireless devices to significantly extend the range of connectivity over that of wired computer, or even wireless telemetry systems.

[0021] In a first embodiment of the present invention, the WWD is a web-enabled mobile phone. Here it is noted that the term “web” or “internet” are used interchangeably to refer to the internet in general. In a second embodiment, the WWD is a palm, handheld, or laptop computer, or a PDA equipped with a wireless modem. In a third embodiment, the WWD may be a hybrid device that combines the functions of a computer, PDA and telephone in some fashion. In a fourth embodiment, the WWD is a web-enabled mobile phone or hybrid device using a satellite communications network.

[0022] In a separate embodiment, an adaptor is used if necessary to convert the output signal of the medical monitoring device to a suitable input signal for the, e.g., WWD. The adaptor allows connection of the WWD to a medical device, exercise machine or other variety of health care equipment, and the connection may be made via several techniques.

[0023] As for wired techniques, a standard parallel bus, universal serial bus (USB), Firewire, serial cable, or similar industry-standard connection may be used if the input/output ports between the HMD and the WWD are appropriate. Otherwise, a suitable separate adaptor may be employed. For example, a serial-to-USB adapter cable may be utilized to connect the serial data port, e.g., RS232, of a medical device to the USB input port of a WWD.

[0024] The connection may also be an input such as a memory device reader, a disk drive or other media input for input of data, a USB port or phone jack or other such wired input, again employing an adaptor if required.

[0025] As for wireless techniques, infrared (IR), microwaves, radio frequency (RF), Bluetooth® (802.15 protocols), Wifi, WifiMax (802.11 protocols), Ultrawideband (UWB) and Wireless USB (W-USB) or other wireless protocols, optical techniques including lasers, and other such techniques may be used. As above, an adapter is used if necessary to convert the output of a medical device to a suitable wireless signal for the WWD, for example, a Bluetooth® virtual serial cable.

[0026] The user, e.g. the patient or a caregiver, may also input data manually, such as by a stylus, keypad, synchronization from a PC, or by various other techniques discussed below.

[0027] A major advantage of the invention is that by use of an optional adaptor, the system is compatible with current and prior HMDs as well as maintaining a capability of adapting to future such systems.

[0028] A digital camera may be integral to the WWD to provide photographic or video images to supplement the data from the HMD. Alternatively, the WWD may be connected to a camera either through a wired or wireless connection. The HMD may also provide image data (e.g., ECG on-screen signals could be transmitted visually if an output connection is not available).

[0029] The interaction between a WWD and a back-end server may provide a major additional advantage in certain

embodiments of the invention. In particular, the relatively small amount of memory currently provided on a WWD as compared to a back-end server severely limits the functionality of applications running on the WWD, especially in terms of computing capacity, processing power, and user interface. By providing significant application functionality on the back-end, less memory and processing capabilities become necessary on the WWD (i.e., on the "front-end"). Thus, memory may be used in the WWD for an enhanced user interface or for other purposes, according to the user requirements. The invention is protocol-independent.

[0030] In a method according to an embodiment of the invention, the user connects to a specific Internet site and a software program, resident on a remote server located on the Internet, downloads an interactive user interface for that patient and an application for the measurement of the medical information. Alternatively, the software may have been previously installed on the WWD by a supplier or a from a memory device, or downloaded to the WWD from a personal computer via a synchronization operation in known fashion.

[0031] The software provides a personalized display for the user and configures the WWD to control and monitor devices connected via a generic input/output port to the WWD. The software may be designed to suit the constraints of the small display screens of WWDs. The software, as well as inputs from the patient or other inputs, can control the manner, content, and display of information presented to the patient, and measured or input data can be stored for review by a health care professional or be processed further by a software algorithm or application. The algorithm may be of varying complexity, from a simple program that merely acknowledges receipt of information to an artificial intelligence algorithm, such as an expert system, collaborative filtering system, rules-based system, case-based reasoning system, or other such artificial intelligence application.

[0032] Further information may be provided to or from the user, including information entered manually. The user may input this information via a personal computer, which then may download the input information to the WWD via a synchronization operation using standard protocols, such as those for Palm PDA devices.

[0033] The user may also input supplemental information via a PC connected independently to the server via the internet. Alternatively, the user may input this information via connection with a another device using standard protocols, wired or wireless connections including Bluetooth®, 802.11 wireless, or infrared wireless connections. For example, a GPS device can be used to provide data about the location of the patient.

[0034] The use of WWD equipped with a "hands-free" earpiece and microphone allows the user to interact with the health care professional while recording medical data. The use of a camera-equipped mobile phone further allows the health care professional to instruct the user to send photographs or video of the patient to assist in the remote diagnosis and treatment of the patient's condition. The deployment of voice processing technology may be used to allow an even more convenient user interface.

[0035] In all of these respects, the portable aspect of the WWD is important: to wit, the user may conveniently carry the WWD on their person wherever they go, allowing data entry at the time needed.

[0036] A health care worker reviewing the data may also input supplemental information via a PC connected independently to the server via the internet to supplement the data input to the WWD. Such supplemental information may include data that is not otherwise available to the user with the patient.

[0037] Other aspects, features, and advantages will be apparent from the summary above, as well as from the description that follows, including the figures and the claims.

BRIEF DESCRIPTION OF THE DRAWINGS

[0038] FIG. 1 illustrates a general embodiment of a wireless health-monitoring system according to the present invention;

[0039] FIG. 2 illustrates an embodiment of a wireless health-monitoring apparatus according to the present invention, showing the system of FIG. 1 up to a point of a wireless antenna 60;

[0040] FIG. 3 illustrates an embodiment of a WWD employing a camera, which may be integral or not, and optional removable memory stick.

[0041] FIG. 4 illustrates an embodiment of a back end of a health-monitoring system according to the present invention;

[0042] FIG. 5 illustrates a data flow diagram according to an embodiment of the present invention;

[0043] FIG. 6 illustrates an embodiment of a method of use for a wireless application and a server application according to the present invention, in which the same is implemented in an emergency medicine setting;

[0044] FIG. 7 illustrates an embodiment of a method of use for a wireless application and a server application according to the present invention, in which the same is implemented for disease and patient management;

[0045] FIG. 8 illustrates an embodiment of a method of use for a wireless application and a server application according to the present invention, in which the same is implemented for health and exercise management;

[0046] FIG. 9 illustrates an embodiment of a wired connection between a HMD and a WWD, also showing an optional adaptor; and

[0047] FIG. 10 illustrates an embodiment of a wireless connection between a HMD and a WWD, also showing a different type of optional adaptor than that in FIG. 9.

DETAILED DESCRIPTION OF THE PREFERRED EMBODIMENTS

[0048] Various acronyms are used for clarity herein. Definitions are given below. The term "HMD" may encompass not only devices with physiologic sensors but also devices with a keypad, keyboard, mouse, pointer, pressure sensor, or other such inputs that the patient or user may employ to perform data entry of the desired parameters. In general, HMDs include some means for determining a health parameter.

[0049] In a disease management embodiment, an HMD may be a blood glucose monitor, a blood pressure monitor, an ambulatory ECG recorder, a respiratory monitor, a temperature monitor and so on.

[0050] In a healthy lifestyle management embodiment, an HMD may be an exercise machine, including treadmills, rowers, steppers, exercise cycles, or other aerobic or anaerobic exercisers, or a monitor, include monitors for temperature, heart rate, blood pressure, amount of work or rate of work performed, etc.

[0051] The term “subject” as used herein primarily indicates a human subject. The same may be a medical patient under a physician’s care or the care of a paramedic or other healthcare professional, a person interested in maintaining health via accurate recording of nutrition and exercise, and so on. The term “user” is generally used to refer to the user of the device, which may be synonymous with the subject or may alternatively be a medically or non-medically trained caregiver of the subject, etc. The term “patient” is used, in addition to a person under the care of a physician, to also refer to a “normal” or healthy individual who is interested in maintaining a healthy physiologic balance.

[0052] The term “signal communication” is used to mean any type of connection between components where the connection is, e.g., electromagnetic, and where the connection allows information to be passed from one component to another. This term may be used in a similar fashion as “coupled”, “connected”, “information communication”, “data communication”, etc. The following are examples of signal communication schemes. As for wired techniques, a standard USB or serial cable may be used if the input/output ports are compatible and an optional adaptor may be employed if they are not. As for wireless techniques, IR, microwaves, RF, e.g., Bluetooth® or 802.11 protocols, optical techniques including lasers, and other such techniques may be used. The user may even input data manually, such as by a stylus or keypad or by various other techniques discussed above and below.

[0053] The term “generic input/output port” is used to mean any type of convention, standard, universal, stock, consumer, or “off-the-shelf” type of port for data input and output. These may include both wired and wireless ports. A further description is given below.

[0054] Various embodiments of the invention are now described in more detail.

[0055] Referring to FIG. 1, a system of the present invention is shown for monitoring health data from a patient or subject 38. The system includes a wireless health-monitoring apparatus (“WHMA”) 10 described in further detail below. WHMA 10 is linked in a wireless fashion to a wireless connection point of presence (“POP”) 19, the same including at least a base station antenna 15 coupled to a server 17. Server 17 is in turn connected to the wired, or even a wireless (not shown) Internet 21, which may include the World Wide Web.

[0056] It should be noted that the base station embodiment shown in FIG. 1 may be replaced or removed for mobile phones which connect via satellite rather than via a cellular network, i.e., “satellite phones”.

[0057] Referring to FIG. 2, a first embodiment of WHMA 10 is shown. WHMA 10 includes an HMD 11, which may

include an optional monitor screen 40, coupled via an optional adaptor 42 to a WWD 12. WWD 12 connects wirelessly via an antenna 60 to base station 15 (see FIG. 1). One function of WWD 12 may be to provide the user interface; other functions are described below.

[0058] As noted above, HMD 11 may include a physiologic sensor 24 or may include a manual system 36 for input of physiologic data via a connection 44. Manual system 36 may also be used to input data directly into WWD 12 via a connection 32. Manual system 36 may include, e.g., a keyboard 30, a mouse 26, a pen-type device 28, and may also employ a separate monitor (not shown). Of course, the user may also view information on monitor 40 or on a screen 41 of WWD 12. In many embodiments, the stylus-based system employed by many current PDA’s, such as the Palm®, may be preferred for such manual data input.

[0059] Data may also be input via entry on a computer 37. This data may then be synchronized to WWD 12 in known fashion. Alternatively, computer 37, or another computer may be used to connect to a server using the wired internet. This use may be particularly advantageous when entering a large amount of data, such as a patient’s medical history. As noted above, in this way the patient may be afforded a more convenient environment in which to manipulate data to supplement the data input to the WWD.

[0060] It will be clear to one of skill in the art given this teaching that cable 32, as well as cables 34 and 44, may be replaced with wireless circuitry to communicate signals wirelessly. Alternatively, cables 34 or 44 may be replaced by a direct plug and socket connection. In this connection, adaptor 42 may be a direct plug and socket connection.

[0061] For medical devices and applications, physiologic sensor 24 may include, e.g., a sensor appropriate for measuring blood glucose levels, blood oxygen levels, blood pressure, electrocardiograms (ECG), heart rate, respiration, or any other desired parameter as required by the physician. Sensor 24 may connect via an optional cable 44 to subject 38. Alternatively, sensor 24 may be distal of HMD 11, i.e., at or within subject 38. In other words, if cable 44 is employed, sensor 24 may be proximal or distal of cable 44. In some applications, such as cardiac monitoring, sensor 24 is implanted within the patient. Alternatively, other health monitors may also be employed so long as the measured data may either be transferred to WWD 12, e.g., via optional adaptor 42, described in further detail below, or by being read by a user, e.g., from a display, and manually input to the WWD.

[0062] If a wireless communications capability is added, sensor 24 need not physically connect with HMD 11 or WWD 12 at all. That is, the same may measure a health parameter and may communicate the same to wireless health-monitoring apparatus 10 wirelessly. The short range wireless communications schemes which may be employed include infrared, radio frequency including Bluetooth or 802.11, or other such schemes.

[0063] As examples of sensor types, to measure blood glucose levels, sensor 24 may be a sensor that accepts a drop of blood, e.g., via a finger-prick. To measure heart rate, sensor 24 may be placed via an adhesive sensor disposed on the chest. Other health monitors may also be employed so long as the measured data may either be transferred to WWD

12, e.g., via optional adaptor 42, described in further detail below, or by being read by a user, e.g., from a display, and manually input to WWD 12. Alternatively, the measured data may be transferred to WWD 12 via wireless communication schemes, such as RF including Bluetooth® or 802.11, infrared, optical, microwaves, etc., directly from sensor 24 or from HMD 11 as described in greater detail below. For some patients, the measured data may be obtained by an implantable device, such as a cardiac monitor, for which a wireless communication scheme would be particularly appropriate.

[0064] The user, who may or may not be the same person as subject 38, may input data to WWD 12 to supplement the measured data. For example, in a health or exercise device, if subject 38 consumes a known number of calories, this information may be entered via manual system 36 directly into WWD 12 or into HMD 11. Further, the user, the subject, and the sensor are not necessarily the sole sources of information. Data stored on the server, or on a separate server operated for health management may also be employed to result in a health benefit to subject 38.

[0065] The data used to benefit the subject 38 may be from a camera as well as from an HMD. Referring to FIG. 3, an embodiment of a WWD 244 is shown equipped with a camera 224 and an optional memory device 246. The camera may be integral to the WWD, or may be separate and connected via a cable.

[0066] Particularly important types of data about a patient that presents with a malady that may be wirelessly transmitted from the WWD are those corresponding to photographic pictures, both still and video, and graphical or visual data output images from an HMD, e.g., an ECG output. In either case, medical personnel may arrive on an emergent scene and engage the WWD. Some action may be taken immediately if warranted.

[0067] To obtain the first type of data noted above, photographic data, a camera may be employed, which is either resident on the WWD or is otherwise available by way of a wired or wireless link. The WWD may store photographic data, either still or video, and transmit the same wirelessly to a point of collection, e.g., a server application, or may save the photographic data on the memory device for contemporaneous or later transmission, again either via a streamed, non-streamed, or other transmission method.

[0068] There are various ways in which visual data may be communicated to an off-site caregiver. A simple method is to send the visual data via an email message. In more advanced methods, the visual data may be integrated with a data stream of other medical information. Current systems may be used in combination with the present invention to facilitate the handling and transmission of visual data by a WWD. In all cases, the visual data may be stored, e.g., as a separate file or may be included as an embedded object in a data file on the memory device or in an email.

[0069] In more detail, a data port from a HMD that is coupled to a patient may be employed to send visual information from the same to an input port on the WWD. This transmission may be accomplished via the techniques described above. Such data may be in either a raw form or in a preformatted-for-video form, and may be stored in the WWD or on the memory device. In either case, it may be

required to format the data in a way suitable for the display screen of the WWD. In some cases, viewing on the WWD is not necessary, and the data may be sent in its original form, optionally undergoing some intermediate processing, directly on to the off-site caregiver's system for viewing or analysis. Examples of this type of data may be ECG data or other sources of data.

[0070] Alternatively, a subset of the data may be sent, such as a compressed version, while the remainder, i.e., the complete version of the patient data, may be maintained on the WWD and/or memory device for purposes of maintaining a complete patient record.

[0071] The memory device 246 may be a smartcard, a smartmedia card, a memory card, memory stick, compact flash card, memory cubes, micro-drives, disk-on-keys, flash memory-keys, micro-laser disks, nano-storage devices, bio-memories, battery/memory combination device, USB flash drives, and so on, or indeed any other type of removable media that may be connected to a WWD to store information. Typically, these memory devices are capable of storing substantial amounts of data. The same may also include a memory and power source or combination device. In another embodiment, the memory device 246 may be inserted (not shown) in a memory device reader, which is in turn connected to a WWD via link.

[0072] Of course, in some devices, including some current mobile phones and PDAs, there is no need for a separate memory device 246 as the internal storage capacity, e.g. in the form of solid state memory, microdrive or other memory storage devices, is sufficient to store all applications and data. Whether via a memory device 246 or internal storage, enhanced functionality and storage are provided for the WWDs 244 or 250. This may be particularly important for medical data, as certain health monitoring apparatuses produce copious amounts of data, e.g., cardiac monitoring equipment, and thus require substantial storage capabilities. This is particularly true for memory-intensive video and multimedia content.

[0073] Another reason such memory devices are particularly pertinent in medical device monitoring is that they store data which can then be wirelessly transmitted in a streamed or non-streamed fashion. In the event of drop-outs, interruptions, or unavailability of the wireless network, no loss of data occurs, as the data has been stored on the memory device and may be wirelessly transmitted at a later time when cellular or mobile service is again available. The memory device thus serves as a back-up storage media. In the event of an extended period of unavailability of a wireless network, the memory device may be replaced or overwritten to provide practically unlimited storage until such time as the network is available and the data can be uploaded. In more detail, in the case of a dropout or other disruption of wireless service, the data may be stored on the memory device or in the WWD if it has not already been, as may be the case for streamed data. The WWD may periodically test for the availability of the wireless network, and may wait until the network is available. Once the system is again available, the advice from the caregiver may be sent to the WWD and the on-site personnel may again take action.

[0074] Of course, even if the wireless network is available, the memory device or on-board WWD memory may store

the data for various purposes. This real-time capability and robustness is often very important in ensuring patient safety and ensuring that a high level of care is being delivered to the patient by the caregiver, particularly in field or emergent situations where the wireless connection may be the only source of communications with a physician.

[0075] A related reason why memory devices are particularly pertinent in medical device monitoring is that they allow a greater level of buffering for real-time data monitoring, thus allowing more pre-analysis and filtering of data.

[0076] A further benefit of the use of memory devices is that they provide for easy application downloading onto a WWD. For example, a memory device may be inserted into a WWD and a large application program may be easily downloaded onto a WWD from the memory device rather than through a wired or wireless synchronization or downloading process via a PC or the internet or both. Downloading in this fashion may be particularly rapid and complete. The downloaded data may include visual data, such as still or video photographic images, that instruct a user on the operation of a device. In an alternative embodiment, the data need not be downloaded but may rather be streamed, either from a stored video on a server or in real-time via a user with a webcam. In downloaded or streamed by generally not live systems, the user interface may be interactive, allowing the user to access a knowledge database resident on the server or memory device or previously downloaded onto the main memory of the WWD.

[0077] Referring to FIG. 4, WHMA 10 is shown communicating wirelessly with the Internet. In doing so, WHMA 10 generally sends a wireless signal to a base station 14 (in known fashion) that is connected to a server 18 that is in signal communication (in known fashion) with the internet. Server 18 communicates via a protocol (in known fashion) to Internet 20, which also communicates via a protocol (in known fashion) to a server 22 running an application 62. Server 22 may be accessed (in known fashion) by a client computer 44 through a connection 64.

[0078] As noted, the protocols for data communication are known. They include cellular networks, wireless networks (such as those using 802.11 protocols) or Broadband and UltraWideband (UWB) protocols and may include a satellite instead of ground-based communication systems. However, they currently vary amongst known techniques. The present invention is not limited to any particular protocols, and may be implemented in any languages supported by the WWD and server. In particular, the wireless communications schemes envisioned by the present invention include cellular, mobile, satellite, and other such wireless techniques. In such wireless communication systems, an additional security layer may be employed, including industry-standard encryption and decryption of the transmitted data, especially as patient health information is highly sensitive and private data

[0079] Of course, as computing capabilities continue to increase, it is expected that the capabilities of WHMA 10, servers 18 and 22, as well as application 62 and client 44, and other components, will correspondingly increase.

[0080] Application 62 running on server 22 may interact with WHMA 10 in a number of ways. Referring to FIG. 5, WHMA 10 is shown in signal communication with server 22

via a connection 72. Connection 72 schematically represents the wireless Internet connection and intervening pathways. WHMA 10 includes an application that may be viewed as having two components: a base wireless or device application 70 and an application presentation layer or user interface 68. User interface 68 is employed to, e.g., present a menu of options to the user, to allow the user to choose inputs, and to generally operate the device. User interface 68 may vary widely in sophistication, e.g., from a simple data entry field to a full graphical user interface. These applications may accept as inputs data from a sensor 24 as well as from a manual input 36.

[0081] Server 22 has a base server application 62 with which the same calculates or provides a response based at least in part on data from WHMA 10. Application 62 may include an algorithm 63 for analyzing data from the HMD, and either application 62 or algorithm 63 may optionally access data from an external data source 74 and may further consult an artificial intelligence system 76.

[0082] External data source 74 may be a memory or disk or other such storage that stores health data, such as healthy and unhealthy weight/height ranges, healthy and unhealthy cholesterol counts, the patient's or subject's prior medical or health history, healthy and unhealthy blood pressure values, information corresponding to the caloric and other nutritional content of foods, information corresponding to the caloric expenditure values of various exercises, algorithms for calculating various health parameters, etc. In general, any data that may benefit the health of a subject or patient may be stored in external data source 74. External data source 74 may be a memory device or other such storage that stores supplemental data such as treatment protocols. In general, any data that may benefit or otherwise affects the medical condition of a patient may be stored in external data source 74. External data source 74 may also include online access of medical information from external databases or other sources.

[0083] As noted, application 62 or algorithm 63 may also consult AI system 76 for suggestions as to health benefits. AI system 76 may even interact with external data source 74 to extract useful information from the same. AI system 76 may employ, e.g., case-based reasoning, rules-based systems, collaborative filtering, neural networks, expert systems, or other such systems as are known.

[0084] It should also be noted that each of application 62, algorithm 63, external data source 74, or AI system 76, may physically reside on more than one server, e.g., on an array of servers for, e.g., storage or multiple processing purposes. Each of application 62, algorithm 63, external data source 74, or AI system 76, or combinations of each, may also respectively reside on different servers.

[0085] The extent to which server application 62 interacts with wireless application 70 depends on the use to which the system is put. For example, in a less interactive embodiment, device application 70 may act to measure a diabetic patient's blood glucose level and report the same to server application 62. In this case, a physician may simply review the measured value and send the patient an email reporting that the value is acceptable or not. In a highly interactive embodiment, a patient may have numerous HMDs 11 connected via optional adaptors to a WWD 12, and wireless application 70 may correspondingly send a large amount of health data to

server application 62. The physician, accessing server application 62, may in turn send detailed care plans to a caregiver via connection 72. The received data may be analyzed using algorithm 63, external data source 74, and AI system 76. In this sense, the two applications may be highly interactive.

[0086] It is noted that an Application Service Provider (ASP) may operate application 62. That is, application 62 may be leased by an ASP to the health care provider, and the ASP may perform all necessary upgrades and maintenance to application 62 and its associated components.

[0087] To initialize the system, the program starts and a wireless application is loaded into the WWD. The loading of the wireless application may occur via synchronization from a desktop or via downloading from a server over the internet. The server application may be loaded into an appropriate internet-connected server. Subject data may be loaded into the WWD or into the server. In the latter case, the subject information may later be transferred to the WWD or transferred to the server from the WWD, as called for by the application. The initialization scheme then ends.

[0088] The wireless application may access the server and server application, or vice-versa, as determined by the respective program instructions.

[0089] Referring to FIG. 6, particularly important types of data about a patient that presents with a malady (step 202 of FIG. 6) that may be wirelessly transmitted from the WWD are those corresponding to photographic pictures, both still and video, and graphical or visual data output images from an HMD, e.g., an ECG output. In either case, medical personnel may arrive on an emergent scene and engage the WWD (step 204 of FIG. 6). Some action may be taken immediately if warranted (step 206 of FIG. 6).

[0090] To obtain the first type of data noted above, photographic data, a camera may be employed, which is either resident on the WWD (camera 224 of FIG. 3) or is otherwise available by way of a link. The WWD may store photographic data, either still or video, and transmit the same wirelessly to a point of collection, e.g., a server application, or may save the photographic data on the memory device for contemporaneous or later transmission, again either via a streamed, non-streamed, or other transmission method (step 208 of FIG. 6).

[0091] To devise the second type of data mentioned above, a data port from a HMD that is coupled to a patient (step 210 of FIG. 6) may be employed to send information from the same to an input port on the WWD. This transmission may be accomplished via the techniques described above. Such data may be in either a raw form or in a preformatted-for-video form, and may be stored in the WWD or on the memory device (step 212 of FIG. 6). In either case, it may be required to format the data in a way suitable for the display screen of the WWD. In some cases, viewing on the WWD is not necessary, and the data may be sent in its original form, optionally undergoing some intermediate processing, directly on to the off-site caregiver's system for viewing or analysis (step 214 of FIG. 6). Examples of this type of data may be ECG data or other sources of data. Alternatively, a subset of the data may be sent, such as a compressed version, while the remainder, i.e., the complete version of the patient data, may be maintained on the WWD and/or memory device for purposes of maintaining a complete patient record.

[0092] The WWD may store the HMD data, and transmit the same wirelessly to a point of collection or may save the data on the memory device for contemporaneous or later transmission, again either via a streamed or other transmission method. The memory device may be a smartcard, a smartmedia card, a memory card, memory stick, compact flash card, memory cubes, micro-drives, disk-on-keys, flash memory-keys, micro-laser disks, nano-storage devices, bio-memories, battery/memory combination device, USB flash drives, and so on, or indeed any other type of removable media that may be connected to a WWD to store information.

[0093] In the case of a dropout or other disruption of wireless service (step 218 of FIG. 6), the data may be stored on the memory device or in the WWD if it has not already been, as may be the case for streamed data (step 216 of FIG. 6). The WWD may periodically test for the availability of the wireless network (step 220 of FIG. 6), and may wait until the network is available (step 218 of FIG. 6). Once the system is again available, the advice from the caregiver may be sent to the WWD and the on-site personnel may again take action (step 206 of FIG. 6).

[0094] Using such data, an off-site health care professional may give an on-site caregiver valuable diagnosis and treatment advice. Moreover, no wired or dedicated connection is necessary.

[0095] More particularly, for visual data, there are various ways in which such data may be communicated to an off-site caregiver. A simple method is to send the visual data via an email message. In more advanced methods, the visual data may be integrated with a data stream of other medical information. Current systems may be used in combination with the present invention to facilitate the handling and transmission of visual data by a WWD. In all cases, the visual data may be stored, e.g., as a separate file or may be included as an embedded object in a data file on the memory device or in an email.

[0096] Examples are now given for (1) a system of disease and patient management and (2) a system for health management employing an exercise machine.

Example Employing System for Disease Management

[0097] Referring to FIG. 7, an example is given for a system of disease and patient management.

[0098] In FIG. 7, a medical device may determine health parameters and an optional physician review is provided. Health parameters may also be determined by user manual input.

[0099] The program is started (step 142) and a sensor measures a health parameter (step 116). The sensor may send the parameter to a medical device (step 118). The medical device then sends the parameter to the WWD (step 120). The WWD then wirelessly communicates the parameter to the application server (step 122), e.g., via the wireless web. The application server processes the parameter (step 124), and calculates or provides a response (step 126) based at least in part on the parameter. The application server may optionally employ algorithm 63 (step 125), external data (step 132) or an AI system (step 134) in the calculation. The

application server then sends the response to the WWD (step 128), where the response is displayed (step 130).

[0100] It should be noted that the term “response” here is used generally may simply be an acknowledgement that the parameter was received by the application server. The term “calculate” is also used generally, and may entail a simple calculation as well as a complex one. A result may, e.g., be the result of a calculation.

[0101] As noted above, the sensor may connect to any type of medical device or other such device in which information pertaining to a patient’s disease or condition may be ascertained. The parameter may be any value corresponding to such information.

[0102] The method may also use a manual input as shown. In this case, after the start (step 142) of the application, the user may interact with the WWD (step 140). The interact may be a data input, a command to read data from a medical device, a response to a physician question or statement, an acknowledgement of physician notification, etc. Calculations by the application server may further take into account supplemental data sent by the user to the server, e.g., in a wired fashion directly over the internet (step 141).

[0103] FIG. 7 also shows a physician review and notification. In this option, the responses are displayed on a client computer (step 136) in signal communication with the application server. A physician may then review the response on the client computer, and notify the patient of the responses (step 138). For example, the physician may notify the patient of positive or negative responses. Of course, it should be noted that the “client computer” may simply be a pager, PDA, WWD, or other such device, as well as a more typical desktop or laptop computer.

[0104] In one implementation, a diabetic may keep a database on a server of a dietary history and a blood glucose history. With this data at-hand wirelessly, the diabetic may choose whether to eat a particular food by entering nutritional information about the food into a WWD, transmitting the same wirelessly to the server, and receiving a recommendation from the server. The recommendation may be based on the food and also on data or information that had previously been transmitted wirelessly, including data from a blood glucose monitor, data input manually, if any, as well as data from algorithm 63, external data source 74, and AI system 76.

Example Employing System for Health Management Using a General Exercise Machine

[0105] Referring to FIG. 8, an example is given for a system of health, nutrition, and/or exercise management. In this example, the HMD is an exercise machine as that termed has been defined above.

[0106] The program is started (step 242) and a sensor measures a health parameter (step 216), where the health parameter corresponds to health, fitness, nutrition, exercise, etc.

[0107] The sensor may send the parameter to the exercise machine (step 218). It is understood here that the “sensor” may be, e.g., a blood pressure monitor, but may also be a simple device connected to an aerobic exerciser that tracks miles ran, work performed, etc.

[0108] The exercise machine then sends the parameter to the WWD (step 220). The WWD wirelessly communicates the parameter to the application server (step 222), e.g., via the wireless web.

[0109] An alternative and complementary way of entering the parameter is by user input (step 248). For example, the user may enter the parameter into the exercise machine or into the WWD. This parameter may correspond to an amount of exercise performed, an amount of food consumed, etc.

[0110] Calculations by the application server may also take into account supplemental data sent by the user to the server, e.g., in a wired fashion directly over the internet (step 241).

[0111] The application server processes the parameter (step 224 and optionally step 225), and calculates a response (step 226) based at least in part on the parameter. The application server may optionally employ external data (step 232) or an AI system (step 234) in the calculation. The application server then sends the response to the WWD (step 228), where the response is displayed.

[0112] The same definitional statements regarding the terms “response”, “calculate”, “sensor”, etc., as given before, apply in this embodiment as well.

[0113] As an optional step, a health specialist may notify the patient or subject of the response (step 238) after having the same displayed on their client computer (step 236). The health specialist may be replaced in this example by an application that may also include an algorithm.

Adaptor Hardware

[0114] A description is given below of a particular type of adaptor hardware. As noted above, the adaptor may optionally be used to connect a HMD to a WWD.

[0115] In general, a connection is necessary between a HMD 11 and a WWD. The nature of this connection may vary. For example, the connection may be wired or wireless. For wired systems, the connection may be direct or an adaptor may be employed, either on one or both ends of the direct wired connection, to adapt the signal appropriately. In the same way, for wireless systems, the connection may be direct, if both HMD and WWD employ the same wireless protocol, or an adaptor may be involved to modify the signal of one or both devices. These connections, all of which are encompassed by the present invention, are discussed in more detail below.

[0116] Referring to FIG. 9, an embodiment of the connection is shown. In this figure, a hardware (or “wired”) connection is shown, i.e., an adaptor 168, disposed between a HMD 160 and a WWD 162. In most circumstances, it is assumed that the varieties of HMDs will vary more widely than the varieties of WWDs. Accordingly, HMD 160 will likely have one of a variety of types of connectors for input/output purposes, here shown as a connector 164. Connector 164 mates with a connector 172 of adaptor 168. At another point on adaptor 168 is a connector 172' for connecting to a generic input/output port 164' on WWD 162. A cable 170 is disposed between the two connectors, cable 170 capable of including adaptor circuitry if desired.

[0117] Of course, the use and structure of adaptor 168, between HMD 160 and WWD 162, depends on factors such

as the prevalence of an industry standard for such communications. In other words, if the output of HMD 160 is readily acceptable to WWD 162, then the same may be directly connected or may be connected via a simple cable, the same basically extending from pin-to-pin. For example, a standard Universal Serial Bus (USB) or serial cable (RS232) may be used if the input/output ports between the HMD and the WWD are compatible. Otherwise, a suitable adaptor circuit that provides for appropriate signal and pin conversion may be employed. For example, a standard USB-to-serial (RS232) cable or the like may be used as required. The connection may also be an input for data, e.g. a USB port or phone jack or other such wired input, or a media storage device, again employing an adaptor circuit if required.

[0118] Port 164 can be used to communicate with HMD 160 and connector 164 via a number of types of wired connections, including USB, or Firewire. In some cases, optional adaptor 168 may also be employed.

[0119] In other embodiments, such as for devices connected to proprietary connectors, a less standard and perhaps proprietary pin-out may be required.

[0120] Referring to FIG. 10, an embodiment of a wireless implementation of the WHMA 10 is shown. In FIG. 10, a wireless connection is shown between HMD 160 and WWD 162. HMD 160 may have an integral wireless modulator/demodulator disposed within (not shown). More likely, however, is that HMD 160 has an adaptor 165 connectable thereto which performs these functions. WWD 162 may have an integral wireless modulator/demodulator (not shown), although an adaptor can also be used in this context.

[0121] While the device shown in FIG. 10 is described in the context of general wireless communications, various protocols may be employed. For radio frequency communications, protocols such as Bluetooth®, 802.11 or Ultrawideband (UWB) or wireless USB may be advantageously employed. Other techniques employing a similar configuration include those employing IR, microwaves, optical techniques including lasers, and so on.

[0122] It should be understood that the above is merely exemplary, and that the form of the adaptor may vary widely between HMDs and WWDs.

[0123] The above description of a remote health monitoring system, termed occasionally a “mobile health-monitoring” system, clearly provides a valuable tool for the remote diagnosis and management of patients.

[0124] Besides the patient data transmission from HMDs, other sorts of transmissions may also occur. For example, visual data, such as photographs or videos, may be transferred as an indication of the patient’s condition and to aid remote diagnosis. Alternatively, other visual indications of a patient’s status, such as graphical or other outputs of HMDs, may provide information useful for a diagnosing/treating physician.

[0125] In certain embodiments, a set of visual data from a camera or from an HMD and voice communication may be transmitted via the telecommunications infrastructure from the WWD. The visual data may thus be sent via an appropriate protocol to a server for retrieval and analysis by a user such as a treating ‘off-site’ physician.

[0126] The advent of multimedia mobile phones and other WWDs that include a digital camera (or are equipped with a link to one) allow the capture and transmission of photographic images using low-cost consumer devices. Embodiments of the invention may employ these in combination with HMDs.

[0127] It will be understood that the above description of a “Method and Apparatus for Health and Disease Management Combining Patient Data Monitoring with Wireless Internet Connectivity” has been with respect to particular embodiments of the invention. While this description is fully capable of attaining the objects of the invention, it is understood that the same is merely representative of the broad scope of the invention envisioned, and that numerous variations of the above embodiments may be known or may become known or are obvious or may become obvious to one of ordinary skill in the art, and these variations are fully within the broad scope of the invention. For example, while certain wireless technologies have been described herein, other such wireless technologies may also be employed. Furthermore, while various types of medical devices have been mentioned, numerous other types may also be used in the embodiments of the invention, including pulse oximeters, implanted monitors, syringe drivers, infusion pumps, spirometers, ventilators, anesthesia monitors, blood glucose meters, automated defibrillators, cardiac monitors, vital signs monitors and so on. Accordingly, the scope of the invention is to be limited only by the claims appended hereto, and equivalents thereof. In these claims, a reference to an element in the singular is not intended to mean “one and only one” unless explicitly stated. Rather, the same is intended to mean “one or more”. All structural and functional equivalents to the elements of the above-described preferred embodiment that are known or later come to be known to those of ordinary skill in the art are expressly incorporated herein by reference and are intended to be encompassed by the present claims. Moreover, it is not necessary for a device or method to address each and every problem sought to be solved by the present invention, for it to be encompassed by the present claims. Furthermore, no element, component, or method step in the present invention is intended to be dedicated to the public regardless of whether the element, component, or method step is explicitly recited in the claims. No claim element herein is to be construed under the provisions of 35 U.S.C. .sectn..sectn.112, 6, unless the element is expressly recited using the phrase “means for”.

1-47. (canceled)

48. A system for monitoring heart rate of a user, comprising:

- a. a heart rate monitor, the heart rate monitor having an infrared port for transmission of signals corresponding to the user’s heart rate; and
- b. b mobile phone, the mobile phone having an infrared port for receipt of the signals corresponding to the user’s heart rate.

49. The system of claim 48, wherein the mobile phone has a display configured to display an indication of the signals corresponding to the user’s heart rate.

50. The system of claim 48, further comprising a computer-readable medium, the medium containing a software application having instructions for causing a computer connected to the internet to:

- a. receive the signals corresponding to the user's heart rate; and
- b. display an indication of the signals corresponding to the user's heart rate.

51. The system of claim 48, wherein the heart rate monitor further comprises a heart sensor disposed on the patient's chest.

52. A method of monitoring heart rate of a user, comprising:

- a. measuring heart rate with a heart rate monitor;
- b. transmitting the results of the heart rate measuring step to a mobile phone by transmitting the results from an infrared transmitter on the heart rate monitor to an infrared receiver on the mobile phone.

53. The method of claim 522, further comprising displaying the results of the heart rate measuring step on a display of the mobile phone.

54. The method of claim 522, further comprising receiving heart rate data from a sensor disposed on the chest of the user.

* * * * *

专利名称(译)	用于健康和疾病管理的方法和装置将患者数据监测与无线互联网连接相结合		
公开(公告)号	US20070232942A1	公开(公告)日	2007-10-04
申请号	US11/649355	申请日	2007-01-03
[标]申请(专利权)人(译)	QUY ROGER J		
申请(专利权)人(译)	QUY ROGER J		
当前申请(专利权)人(译)	QUY ROGER J		
[标]发明人	QUY ROGER J		
发明人	QUY, ROGER J.		
IPC分类号	A61B5/02 A61B5/00 A61B5/021 A61B5/024 A61B5/0432 G08B1/08 G08B21/02 H04L12/56 H04N7/173 H04W24/00 H04W88/02		
CPC分类号	A61B5/0008 A61B5/0022 A61B5/02438 A61B5/04325 A61B5/14532 A61B5/6826 A61B5/6838 G06F19/322 G06F19/3418 G06F19/3456 G06F19/3475 G08B21/02 G08B21/0211 G08B21/04 H04N1/00127 H04N1/00244 H04N1/00307 H04N7/17318 H04N7/185 H04N21/41407 H04N21/42201 H04N21/4223 H04N21/44213 H04N21/4782 H04N2201/0084 H04W24/00 H04W88/02 Y10S128/903 Y10S128/904 A61B5/021 G06F19/3481 G16H10/60 G16H20/30 G16H40/67 A61B5/0013 A61B5/0077 A61B5/1112 A61B5/6801 A61B5/743 A61B2562/0219 A63B22/0076 A63B22/02 A63B22/04 A63B22/0605 A63B22/0664 A63B24/0021 A63B24/0062 A63B71/0622 A63B2071/0663 A63B2071/0666 A63B2220/12 A63B2220/20 A63B2220/40 A63B2220/62 A63B2225/20 A63B2225/50 A63B2230/06 A63B2230/30 A63B2230/50 A63B2230/70 G09B5/06 G09B19/003 G16H20/10 G16H20/40 G16H20/60 H04N5/23293		
优先权	60/172486 1999-12-17 US		
外部链接	Espacenet USPTO		

摘要(译)

本发明的实施例提供了一种用于无线健康监测系统的的方法和装置，用于通过将移动电话连接到数字照相机和/或医疗监测设备来交互地监测患者的疾病或健康状况。来自摄像机的健康相关数据或视觉信息使用标准互联网协议传输到服务器，并且可以与用于手持或无线设备的各种操作系统集成，尤其是具有用于处理图像和视觉数据的增强能力的那些操作系统。

