

US008469884B2

(12) **United States Patent**
David et al.

(10) **Patent No.:** **US 8,469,884 B2**
(45) **Date of Patent:** ***Jun. 25, 2013**

(54) **MEDICAL SENSOR KIT FOR COMBINATION WITH A CHAIR TO ENABLE MEASUREMENT OF DIAGNOSTIC INFORMATION**

60/205,369, filed on May 18, 2000, provisional application No. 60/205,144, filed on May 18, 2000.

(75) Inventors: **Daniel David**, Ranana (IL); **Irving Levy**, Rishon Lezion (IL)

(51) **Int. Cl.**
A61B 5/00 (2006.01)
A61B 19/00 (2006.01)
A47C 7/62 (2006.01)
A47C 31/00 (2006.01)

(73) Assignee: **Commwell Research and Development, Ltd.**, Kfar Saba (IL)

(52) **U.S. Cl.**
USPC **600/301**; 600/300; 128/897; 297/217.1; 297/217.2; 297/217.3; 297/217.7

(*) Notice: Subject to any disclaimer, the term of this patent is extended or adjusted under 35 U.S.C. 154(b) by 0 days.

(58) **Field of Classification Search**
None
See application file for complete search history.

This patent is subject to a terminal disclaimer.

(56) **References Cited**

(21) Appl. No.: **13/540,276**

U.S. PATENT DOCUMENTS

(22) Filed: **Jul. 2, 2012**

3,906,931 A 9/1975 Terekhov
4,082,348 A * 4/1978 Haury 297/45
(Continued)

(65) **Prior Publication Data**

US 2012/0271122 A1 Oct. 25, 2012

FOREIGN PATENT DOCUMENTS

DE 696 13 197 T2 12/2001
EP 0760225 3/1997

Related U.S. Application Data

(Continued)

OTHER PUBLICATIONS

(63) Continuation of application No. 13/092,570, filed on Apr. 22, 2011, now Pat. No. 8,211,014, and a continuation of application No. 12/724,141, filed on Mar. 15, 2010, now Pat. No. 8,235,895, which is a continuation-in-part of application No. 10/890,042, filed on Jul. 13, 2004, now abandoned, and a continuation-in-part of application No. 10/276,455, filed on Nov. 18, 2002, now Pat. No. 6,832,987, said application No. 10/890,042 is a continuation of application No. 10/276,455, filed as application No. PCT/US01/16360 on May 18, 2001, now Pat. No. 6,832,987, said application No. 13/092,570 is a continuation of application No. 10/890,042, filed on Jul. 13, 2004, now abandoned.

European Search Report, dated Jan. 13, 2012, Application No. EP 11 19 4367.6.

(Continued)

Primary Examiner — Bill Thomson

Assistant Examiner — Shirley Jian

(74) *Attorney, Agent, or Firm* — Banner & Witcoff, Ltd.

(60) Provisional application No. 61/160,135, filed on Mar. 13, 2009, provisional application No. 60/232,708, filed on Sep. 15, 2000, provisional application No.

(57) **ABSTRACT**

A medical examination chair kit includes a group of sensors including electrodes in finger-tip sensors, various other types of sensors incorporated in covers attachable or placeable on a chair and load cells on an adjustable grid supporting the chair, all of which provide data which is partially processed in a transmission pocket mounted on the chair.

7 Claims, 10 Drawing Sheets

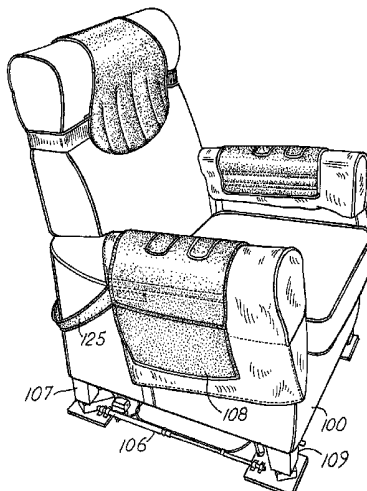

U.S. PATENT DOCUMENTS

4,195,643 A 4/1980 Pratt, Jr.
 4,702,108 A 10/1987 Amundsen et al.
 4,949,729 A 8/1990 Haski
 5,210,706 A 5/1993 Nishiyama
 5,299,454 A 4/1994 Fuglewicz et al.
 5,331,549 A 7/1994 Crawford, Jr.
 5,410,471 A 4/1995 Alyfuku et al.
 5,441,047 A 8/1995 David et al.
 5,511,571 A 4/1996 Adrezin et al.
 5,544,649 A 8/1996 David et al.
 5,620,003 A 4/1997 Sepponen
 5,715,548 A 2/1998 Weismiller et al.
 5,861,582 A 1/1999 Flanagan et al.
 5,885,231 A 3/1999 Cramer et al.
 5,987,982 A 11/1999 Wenman et al.
 6,009,764 A 1/2000 Fukunaga
 6,063,046 A 5/2000 Allum
 6,163,903 A 12/2000 Weismiller et al.
 6,223,606 B1 5/2001 Burke et al.
 6,416,485 B1 7/2002 Rovetta et al.
 6,450,840 B2 9/2002 Nakamura
 6,829,942 B2 12/2004 Yanai et al.
 6,832,937 B1 12/2004 Wrede et al.
 6,832,987 B2 12/2004 David et al.
 7,396,331 B2 7/2008 Mack et al.
 7,785,257 B2 8/2010 Mack et al.
 2003/0083587 A1 5/2003 Ferek-Petric

2003/0208109 A1 11/2003 David et al.
 2004/0082870 A1 4/2004 Rudy et al.
 2004/0186358 A1 * 9/2004 Chernow et al. 600/300
 2004/0260156 A1 12/2004 David et al.
 2005/0251914 A1 11/2005 Schaller et al.
 2006/0129047 A1 6/2006 Ruotoistenmaki
 2006/0219445 A1 * 10/2006 Yamashita 177/245
 2008/0077020 A1 3/2008 Young et al.
 2010/0210921 A1 8/2010 Park et al.
 2011/0034784 A1 2/2011 David et al.

FOREIGN PATENT DOCUMENTS

EP 1074217 A1 2/2001
 EP 1 126 556 A2 8/2001
 WO 91 01111 A 2/1991
 WO 98 34577 A 8/1998
 WO 98 52467 A 11/1998

OTHER PUBLICATIONS

Francis, D.B. et al., "Compensating the VCG for Variations in Electrode Positions", Proceedings of the 20th Annual Conference of Engineering in Medicine and Biology, Nov. 13-16, 1967.
 Sunemark, M. et al , "Serial VCG/ECG Analysis Using Neural Networks", Computers and Biomedical Research, Academic Press, London, vol. 31, Jan. 1, 1998, pp. 59-69.

* cited by examiner

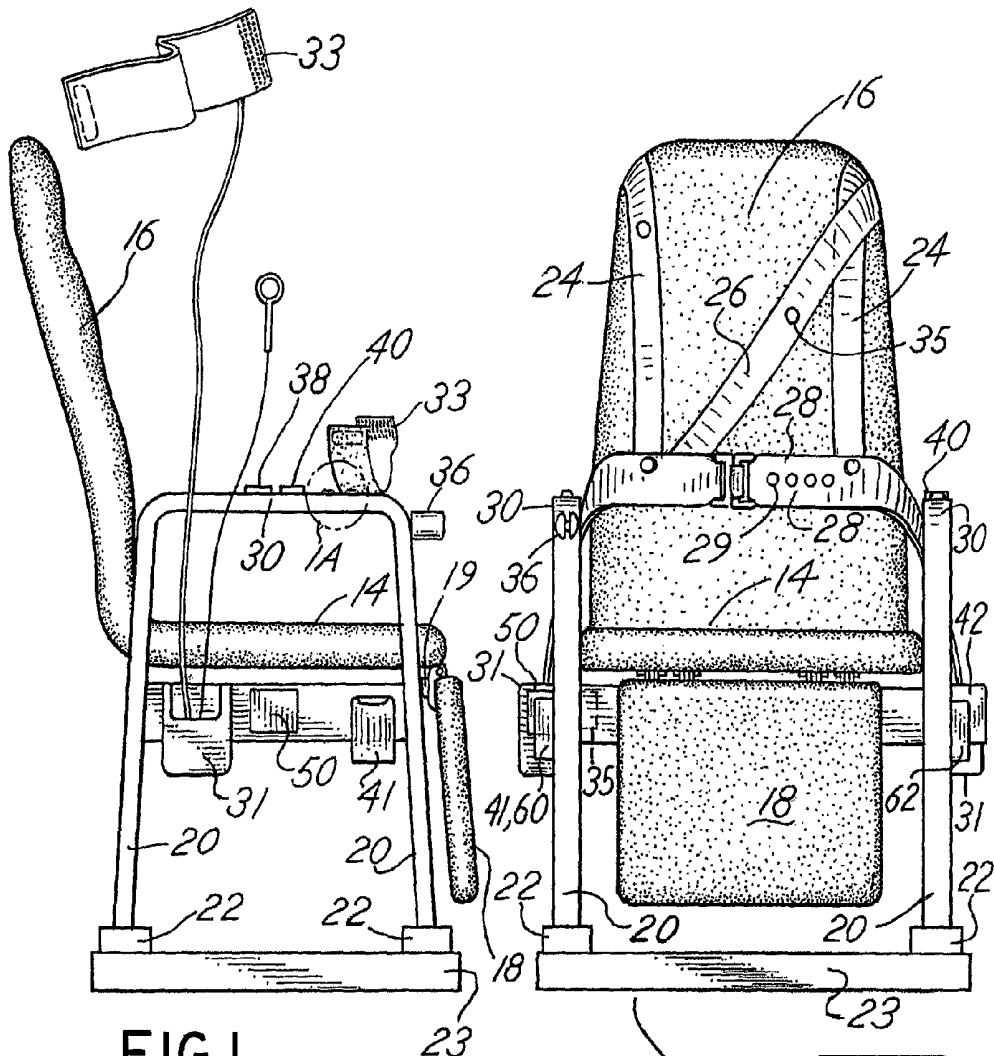

FIG. 1

FIG. 2

FIG. 1A

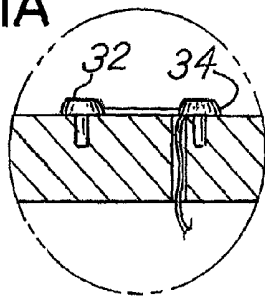
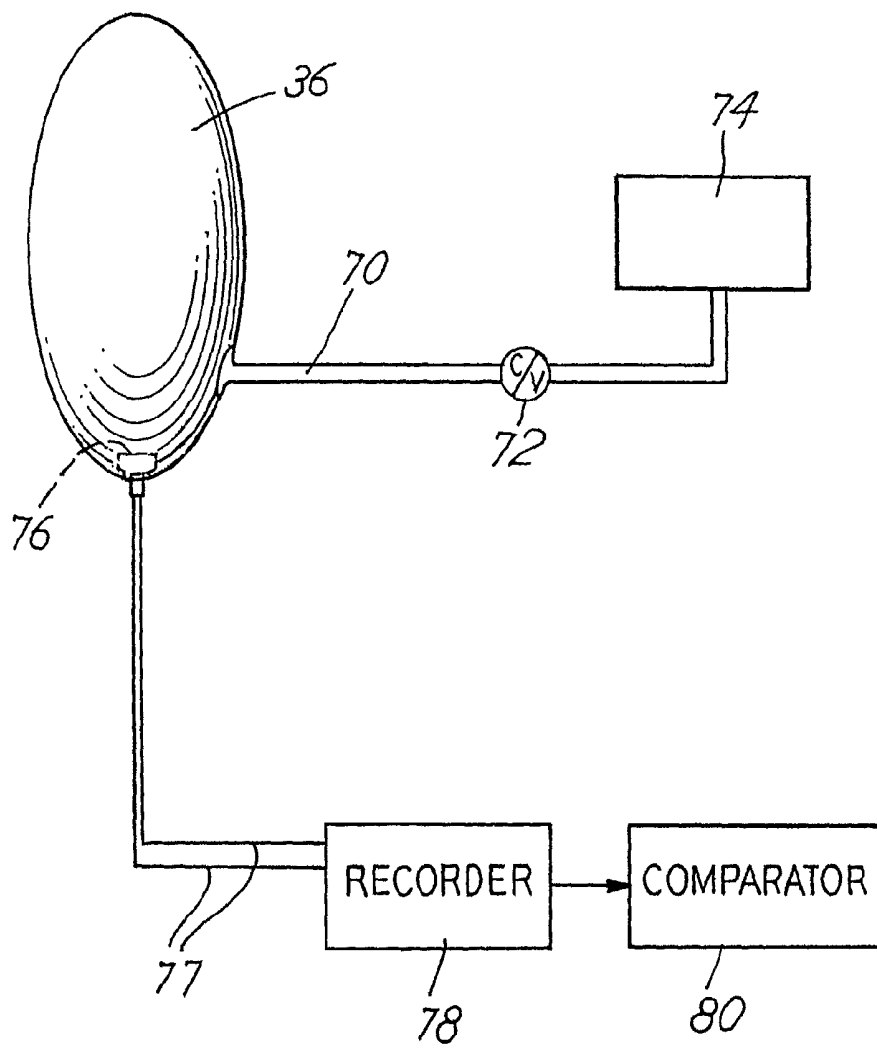

FIG. 3



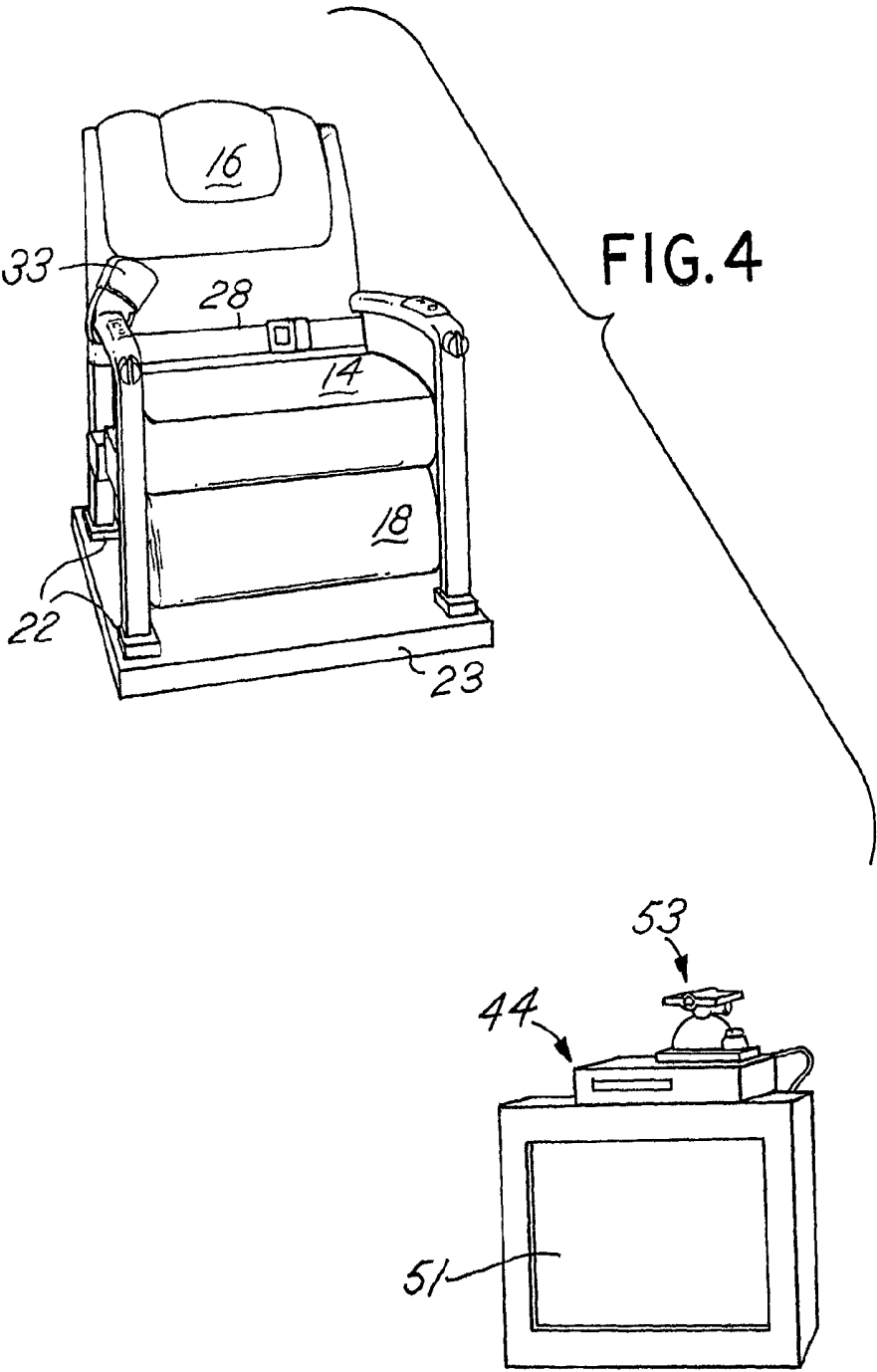
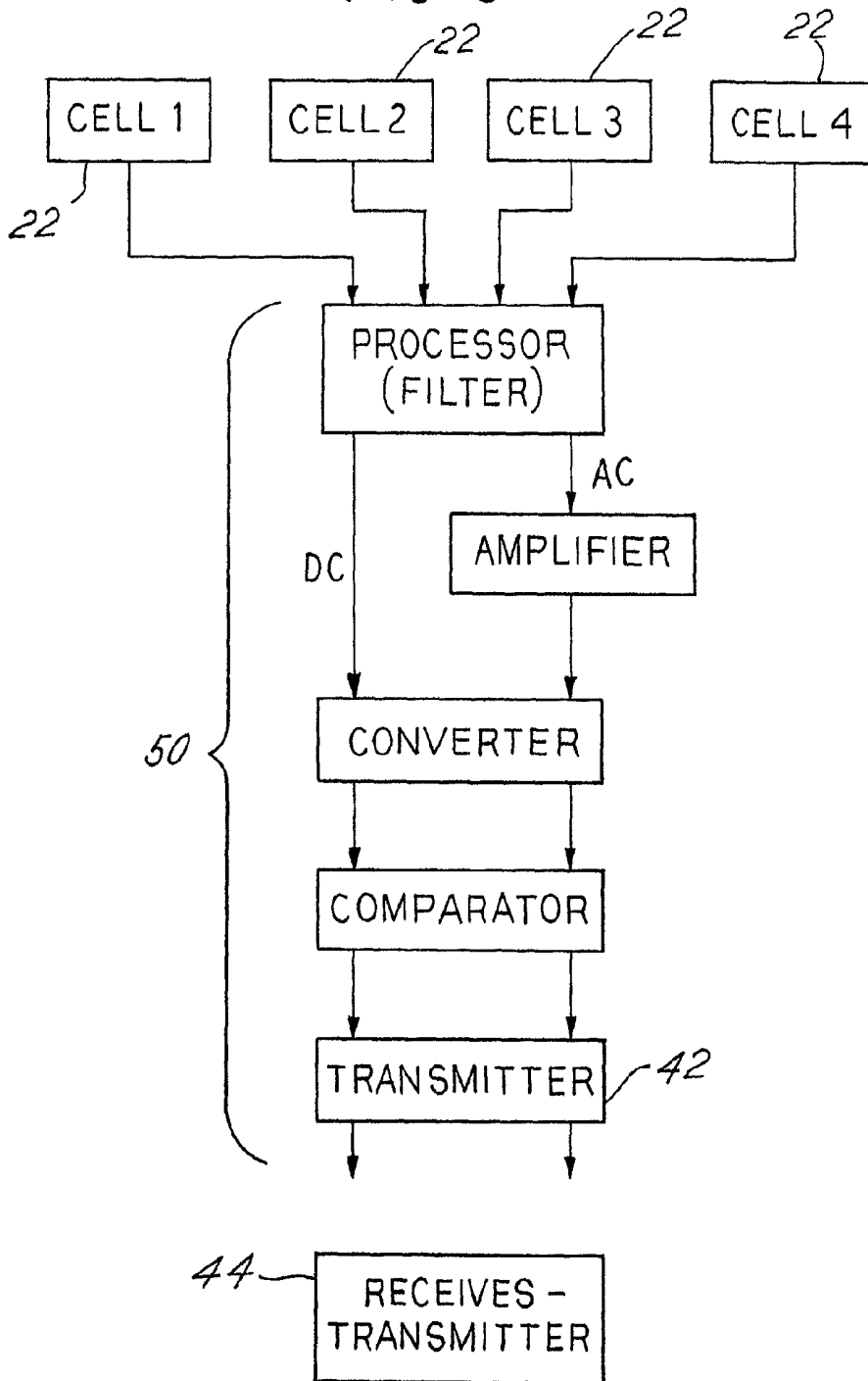

FIG. 5



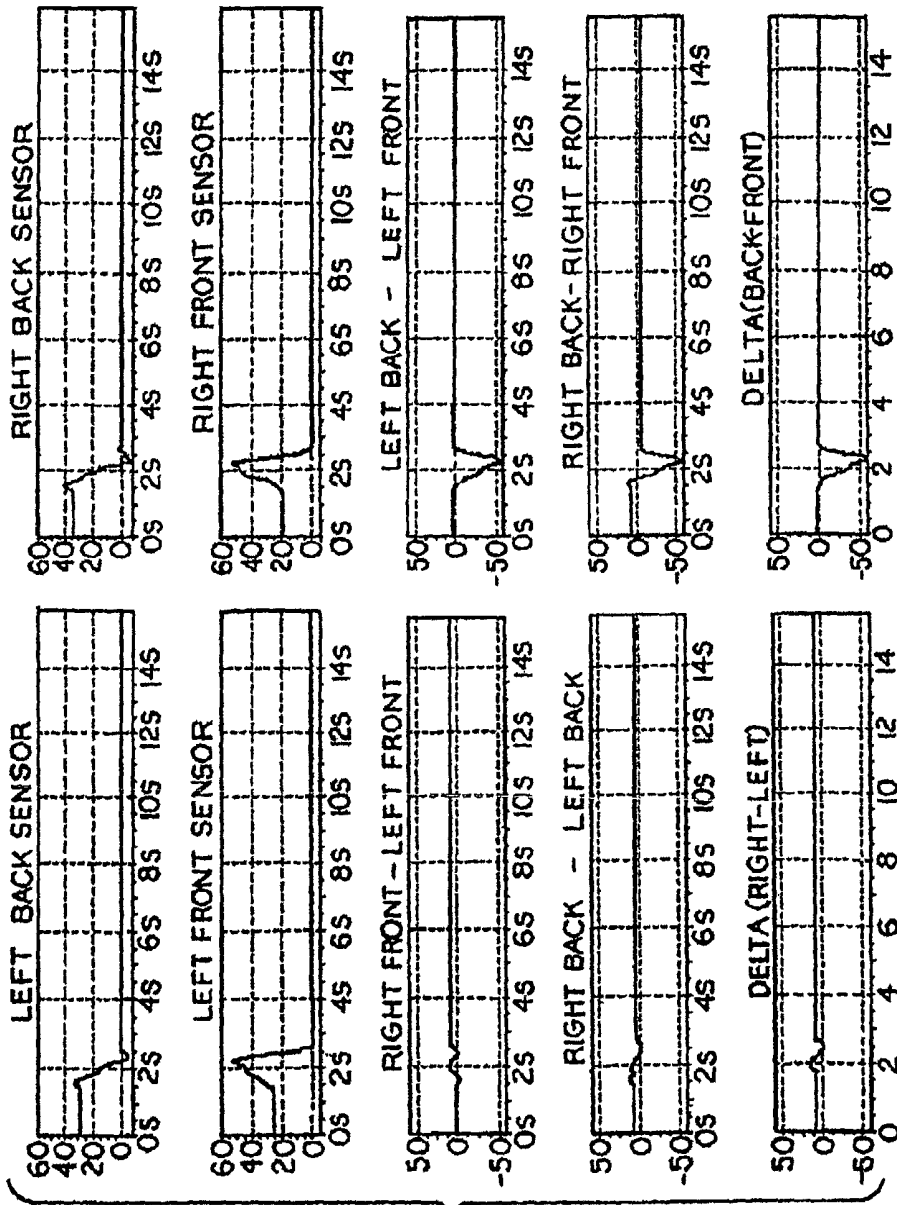

FIG.6

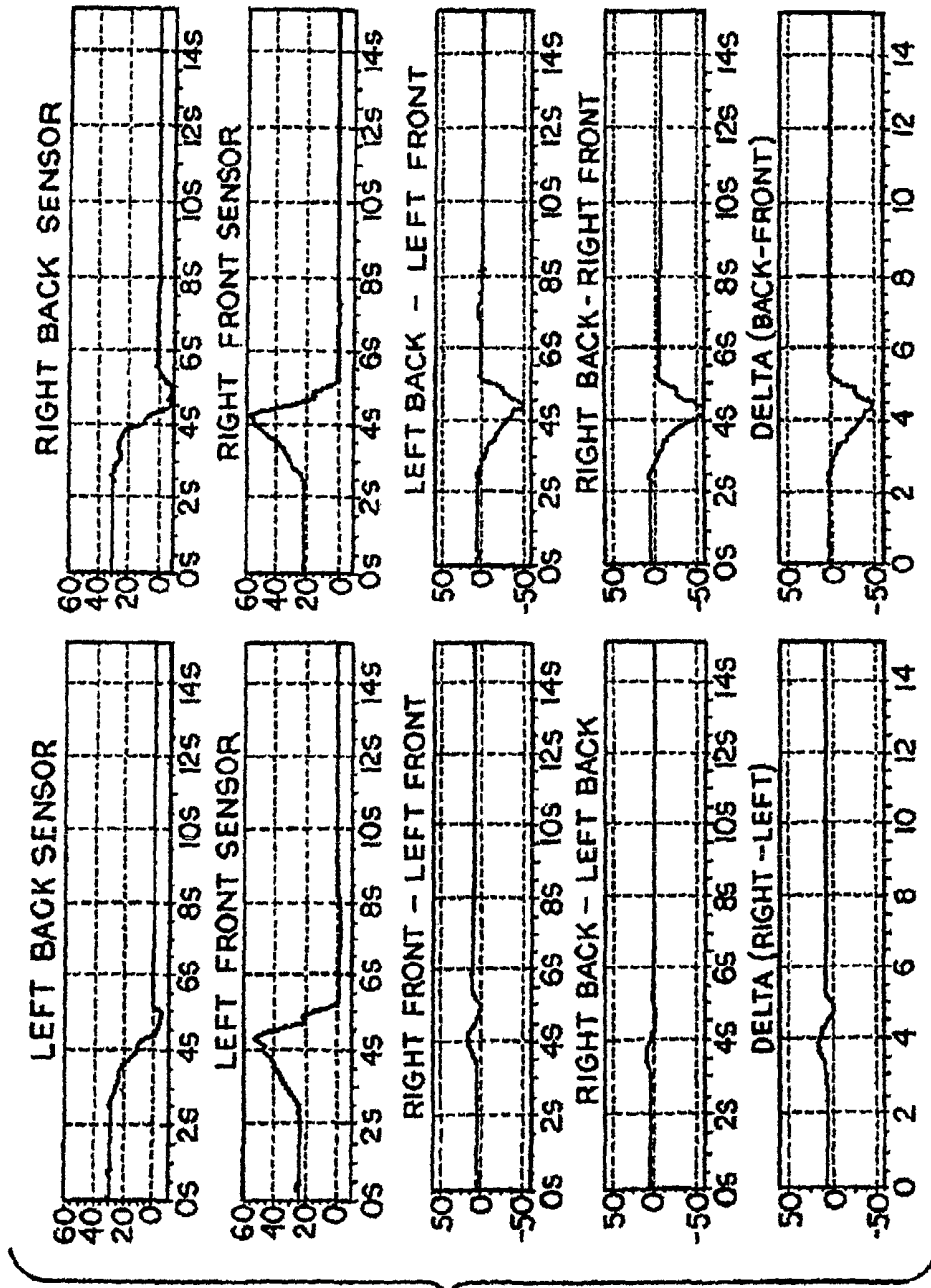

FIG. 7

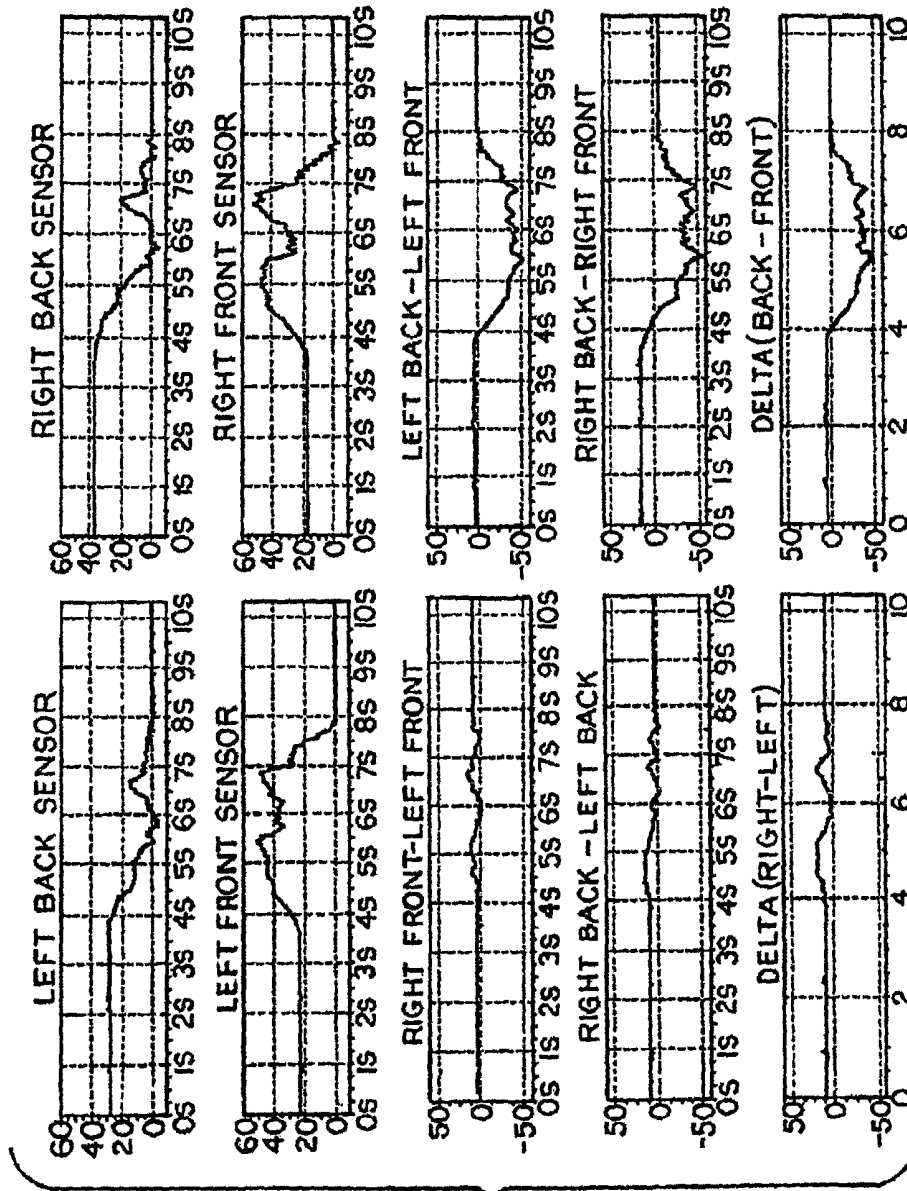

FIG.8

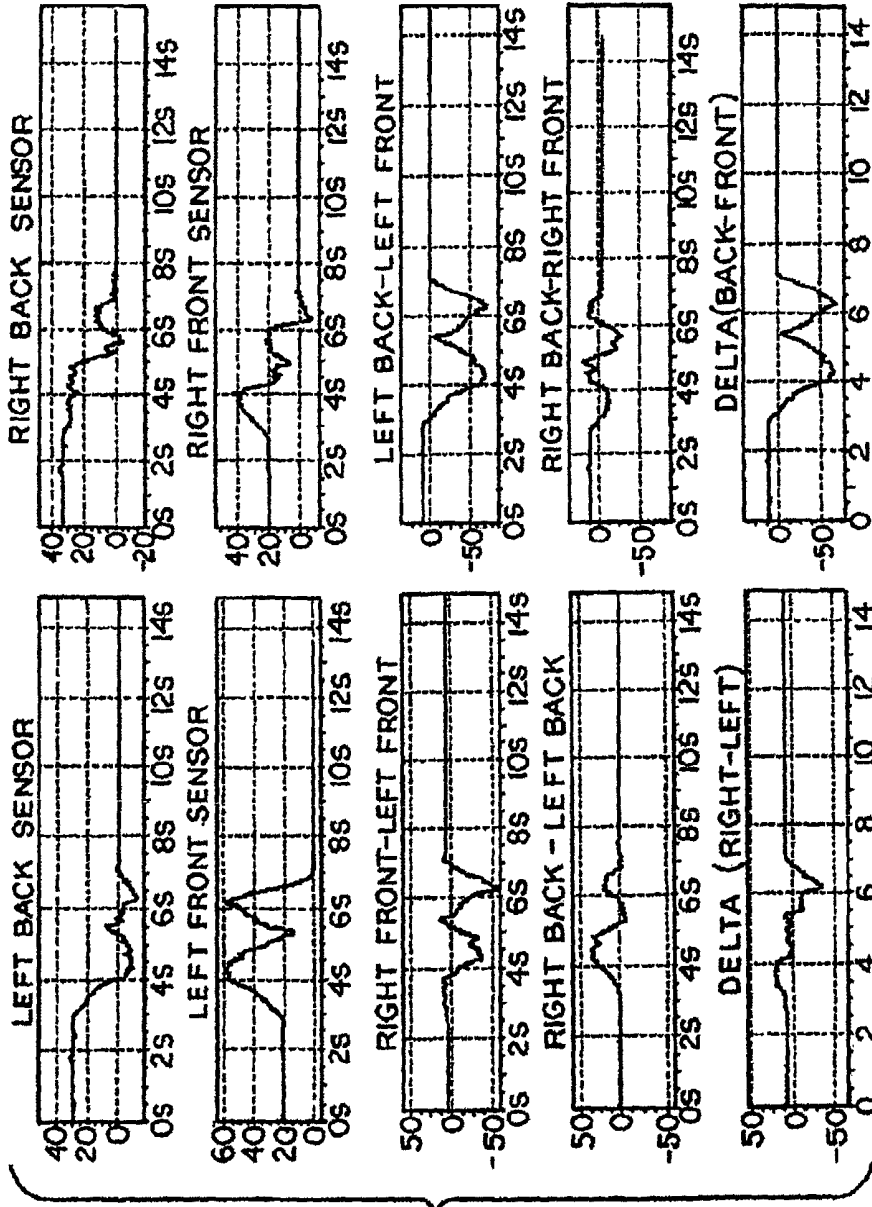
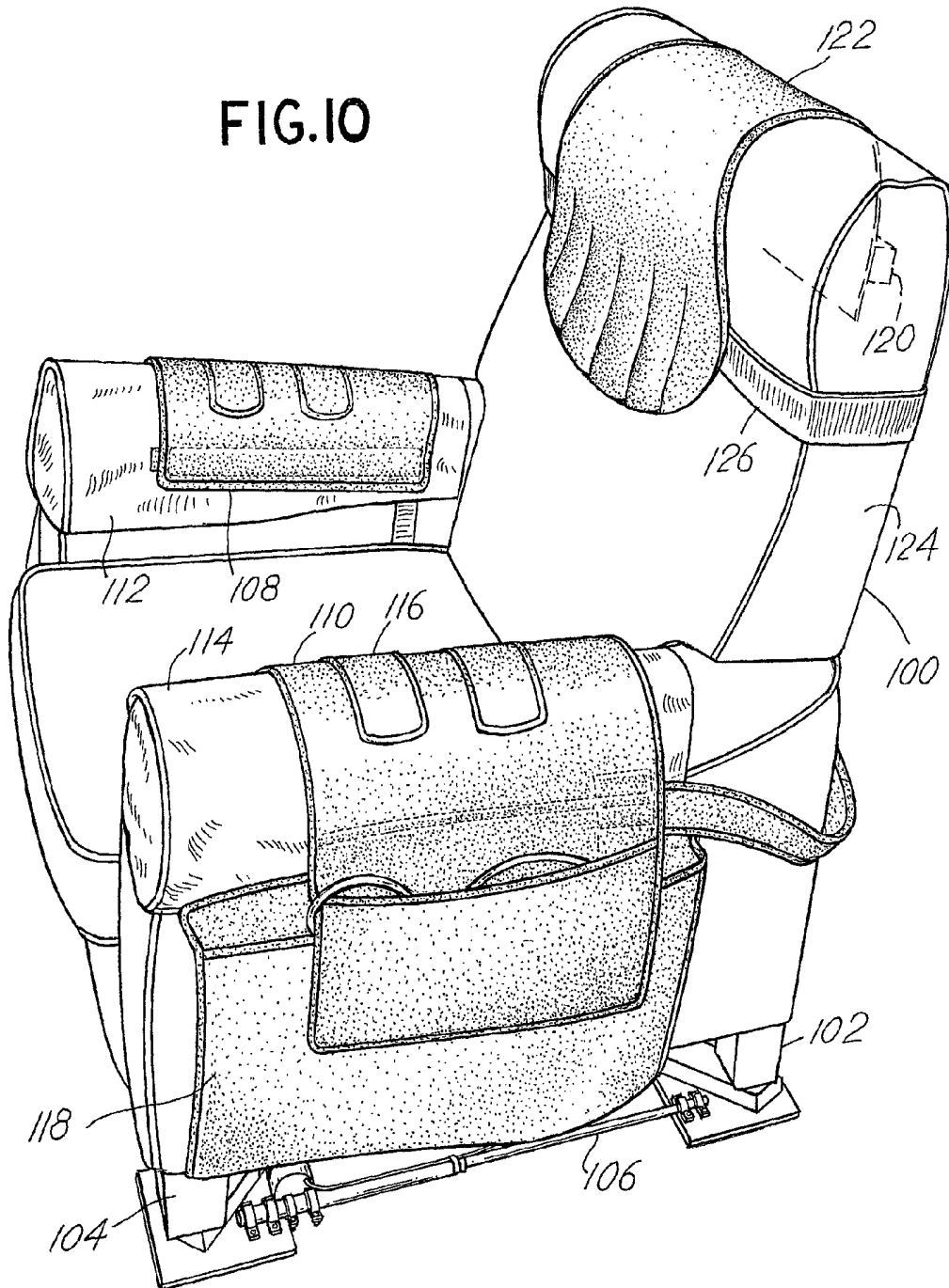
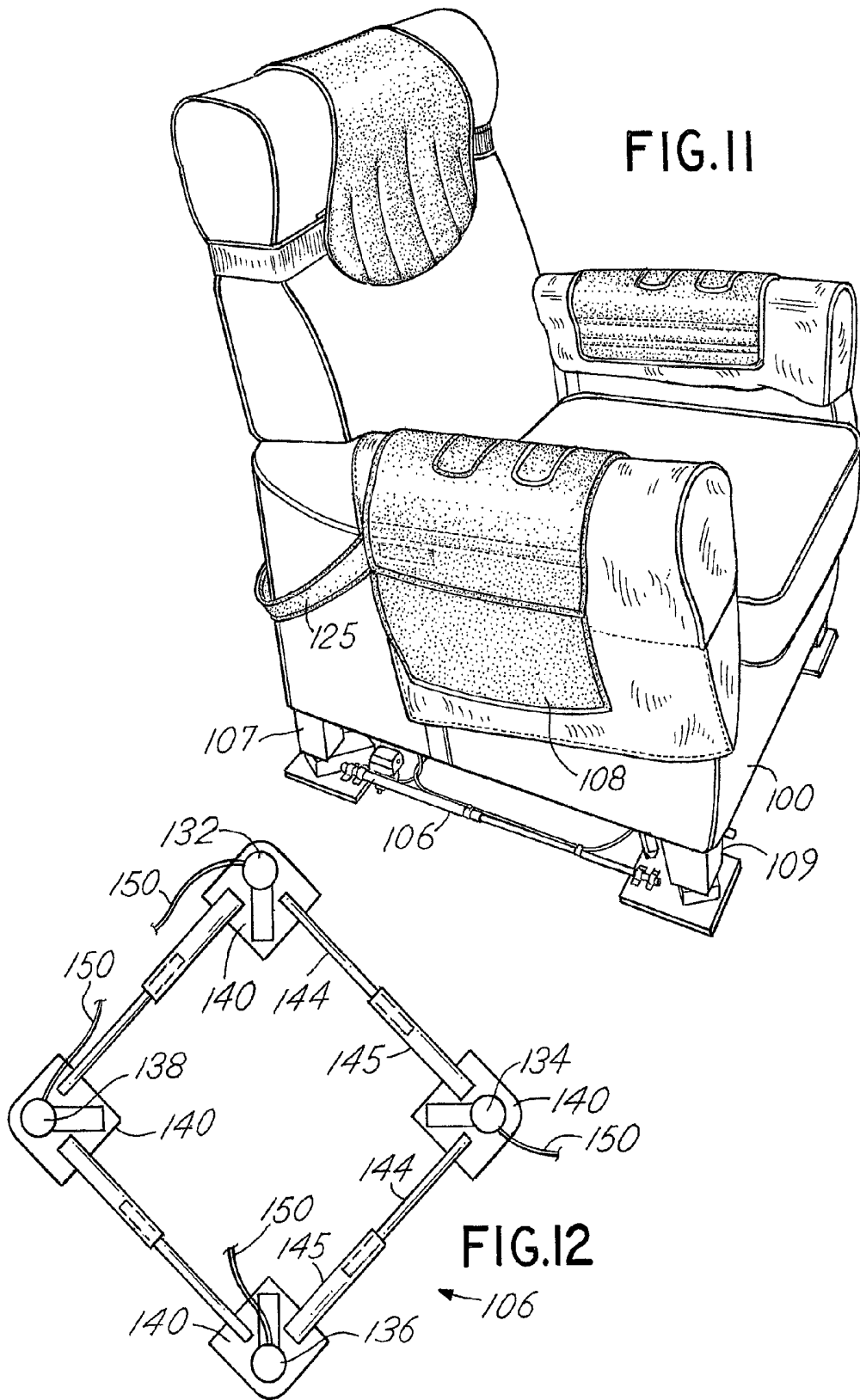

FIG. 9

FIG. 10





**MEDICAL SENSOR KIT FOR COMBINATION
WITH A CHAIR TO ENABLE
MEASUREMENT OF DIAGNOSTIC
INFORMATION**

CROSS REFERENCE TO RELATED
APPLICATIONS

This is a continuation application of the following applications which are incorporated herein by reference and for which priority is claimed: (1) application Ser. No. 12/724,141 filed Mar. 15, 2010, which claims the benefit of Ser. No. 61/160,135 filed Mar. 13, 2009 entitled "Medical Sensor Kit for Combination with a Chair to Enable Measurement of Diagnostic Information" and is a continuation in part of application Ser. No. 10/890,042 and application Ser. No. 10/276,455 (2) continuation application Ser. No. 13/092,570 filed Apr. 22, 2011 (now U.S. Pat. No. 8,211,014) which is a continuation of Ser. No. 10/890,042 filed Jul. 13, 2004 entitled "Chair and Ancillary Apparatus with Medical Diagnostic Features in a Remote Health Monitoring System", which is a continuation of utility application Ser. No. 10/276,455 filed Nov. 18, 2002 (now U.S. Pat. No. 6,832,987) entitled "Chair and Ancillary Apparatus with Medical Diagnostic Features in a Remote Health Monitoring System" which is based on PCT/US01/16360 filed May 18, 2001, which is a utility application based upon and incorporating by reference the following three provisional applications: Ser. No. 60/232,708 filed Sep. 15, 2000 entitled "Chair and Ancillary Apparatus with Medical Diagnostic Features in a Remote Health Monitoring System", Ser. No. 60/205,369 filed May 18, 2000 entitled "Chair and Ancillary Apparatus with Medical Diagnostic Features", and Ser. No. 60/205,144 filed May 18, 2000 "Hand Grip Monitoring Device", upon which we claim priority.

BACKGROUND OF THE INVENTION

In a principal aspect, the present invention relates to a kit that may be mounted or incorporated with a chair for use in the conduct of medical diagnostic tests in a diagnostic system wherein the subject may be remotely located from a control center.

U.S. Pat. No. 5,544,649, incorporated herewith by reference, discloses various techniques for interactive patient monitoring from a central station, (e.g., a clinic) of patients located at a remote site, (e.g., their home). The diagnostic techniques disclosed in U.S. Pat. No. 5,544,649 rely, at least in part, upon utilization of apparatus, such as a diagnostic chair incorporating various sensor apparatus to facilitate the conduct of diagnostic measurements. U.S. Pat. No. 5,544,649 discloses a chair which includes sensors for measuring patient temperature, blood pressure and the like, and for transmitting such data via alternative transmission means to a central station for analysis and diagnosis.

The diagnostic session involving a patient in a remote location chair may be interactive. That is, the health care professional at the central station and the patient at the remote site are in real time, two-way audio and video communication and diagnostic data sensed at the remote location is simultaneously provided in real time to the central station. Such communication enhances the validity and the scope of the diagnostic tests being conducted.

The diagnostic information is analyzed by personnel at the central station. This provides a convenient and low cost manner in which to monitor patient condition without requiring the patient to physically travel to a diagnostic clinic or hos-

pital. This technique and the associated apparatus also enable the health practitioner to direct the patient through test protocols and to diversify or revise the test protocols as necessary during the interactive session.

The use of apparatus of this type disclosed, and, in particular, a chair and various other ancillary equipment have become the topic of continued research and development in order to provide apparatus which senses the diagnostic parameters necessary to provide immediate and appropriate patient health care or monitoring in an inexpensive, yet highly reliable manner. Such continued research and development has led to the discovery of the apparatus disclosed in U.S. Pat. No. 6,832,987 issued Dec. 21, 2004 for a Chair and Ancillary Apparatus with Medical Diagnostic features in a Remote Health Monitoring System and also provides for the combination of such apparatus in an interactive diagnostic system U.S. Pat. No. 6,832,937 is incorporated herewith by reference.

The cost and care of a chair and associated apparatus may inhibit the practical adoption of the technology taught in the aforesaid references. Thus, there has developed a need to develop more usable, cost effective systems for remote monitoring of diagnostic health parameters or information.

SUMMARY OF THE INVENTION

Briefly, the present invention relates to the construction and design of a diagnostic sensor kit for use in combination with a chair or other support platform device used for subject monitoring and medical examination and to the combination of such a device with a system for remote monitoring from a central station.

The device in the form of a kit incorporates numerous apparatus for the acquisition of physiological and other diagnostic parameters from a subject who is sitting in a chair to which the kit has been attached. In a preferred embodiment, a conventional chair is utilized in combination with a kit which accepts commands for the acquisition and analysis of diagnostic data and sends the results, either processed on site and/or as raw data, by wireless communication to a relay system located at the site. The relay system then transfers data received from instrumentation incorporated in the kit to a central system by means of a wide bandwidth public channel (e.g., wireless network, telephone system, cable modem or other public utility). Communication and sensor control is interactive. That is, the transmissions are two-way transmissions. Additionally, other communication channels are simultaneously operative, e.g., audio and video are interactive. Simultaneous, two-way transmission on three channels results in the capacity to diagnose and, to a limited extent, treat a patient at a remote site interactively. The channels may also be integrated for example by modulation or packing of a single channel signal.

By way of example and not limitation, the following medical information and testing, protocols are enabled by the kit design: (1) finger-tip ECG, (2) "safety-belt" diagnostic ECG, (3) non-invasive blood pressure, (4) weight, (5) balance, (6) respiration rate, (7) saturated pulse oximetry (SpO₂), (8) blood glucose analysis, (9) lung sounds, (10) expiratory flow (respiration exhale and/or inhale flow rates), (11) skin resistance, and (12) hand grip strength. All of the instrumentation required for the various measurements recited are an integral part of the kit. No special knowledge, expertise, or physical dexterity is required on the part of the patient or subject to participate in the test procedures since all of the instruments are an integral part of the kit which is easily attached to a conventional chair. The chair provides an ergonomically safe

support for the patient, an aesthetically pleasant appearance and the kit includes storage for the sensors and instruments not in use.

Exemplary of the diagnostic capabilities of the system is measurement of hand grip strength of a patient. That is, a hand grip instrument can detect whether the patient suffers from tremors when gripping an object and thus can be relied upon as a diagnostic tool to evaluate the health of a patient. Apparatus which provide information of this general nature also allows assessment of motor activity which is associated with neurological features or capacity of a patient as well as strength which is associated with the muscle characteristics of a patient. Such monitoring is capable of projecting the likelihood or impact of stroke, for example, and other patient abnormalities.

Thus, a hand grip monitoring device which, in one embodiment, includes a bladder in the form of an elongated ellipsoid may be provided. A source of pressurized fluid is provided to the bladder with a check valve connected to the bladder filled with a predetermined volume of fluid (e.g., gas or liquid). A sensor is connected to the bladder for monitoring the fluid pressure in the bladder and providing a first signal which represents the absolute pressure therein and a second signal representative of the change in pressure over time. A recorder may be provided for recording the first and second signals. Data associated with the first and second signals is analyzed, the first signal being representative of the total energy associated with patient grip and the second signal associated with tremors or a change in pressure with time. As indicated heretofore, tremors may be indicative of neurological status, neuromuscular pathology or stroke. The system may include historical recordings of like signals or a library of data to compare with the measurement or sensed signals in order to determine the change in patient health with time. Alarms may be provided to alert the medical technician at the central station of deviation beyond the general patient specific norm.

Another example involves load cells incorporated on a grid structure that is mounted to the support legs of a chair. The cells detect shifts in weight which, in turn, can be relied upon to diagnose balance and other physiological characteristics of a patient.

The chair and its associated diagnostic sensors may be utilized in combination with a remote monitoring system or infrastructure which operates from a central station by communication techniques with multiple, remote sites.

It is an object of the invention to provide a diagnostic kit for attachment to or combination with a chair and other ancillary apparatus used in combination with the chair to provide sensors that reliably interact with a patient for the measurement of respiration rate, pulmonary condition, heart condition, muscle strength, blood pressure, and other physiological parameters.

Yet a further object of the invention is to provide a highly reliable, yet inexpensive diagnostic apparatus comprised of a kit which is compact and which may be combined with a chair at a remote location yet easily transported from one location to another and easily interfaced with another chair and sensor transmission equipment and with a remote diagnostic system of the type generally depicted in U.S. Pat. No. 5,544,649.

Another object of the invention is to provide a kit for a chair which maybe utilized to obtain diagnostic data from subjects located at a remote site for transmission to and recordal at a central station in order to obtain an historic record of the subject indicative of the wellness or deterioration in wellness of the subject or the status of recovery of the subject.

These and other objects, advantages and features of the invention will be set forth in the detailed description which follows.

BRIEF DESCRIPTION OF THE DRAWING

In the detailed description which follows, reference will be made to the drawing comprised of the following figures:

FIG. 1 is a side elevation of an embodiment of a chair with integrated sensing apparatus;

FIG. 1a is an exploded sectional view of a portion of the chair depicted in FIG. 1;

FIG. 2 is a front elevation of the chair of FIG. 1;

FIG. 3 is a schematic view of a hand grip sensor utilized in combination with a chair or with a kit for a chair;

FIG. 4 is a diagrammatic view of a diagnostic chair having integrated sensors or a kit incorporated in a remote monitoring system;

FIG. 5 is a block diagram of the signal processing protocol for the load cells associated with measurement of weight, balance, respiration rate and other physical characteristics of a subject;

FIG. 6 is a series of graphs depicting the readings from load cells on a time scale and further depicting readings which represent the sum of various combinations of signals;

FIG. 7 is a series of graphs similar to FIG. 6 representing a distinct physiological pattern;

FIG. 8 is another series of graphs similar to FIG. 6 representing a further distinct physiological pattern; and

FIG. 9 is another series of graphs similar to FIG. 6 representing a further distinct physiological pattern or event;

FIG. 10 is a photograph of a typical chair in combination with a sensor kit for measurement of diagnostic information;

FIG. 11 is a photograph of the chair of FIG. 10 depicting the opposite side of the chair and the attached sensor kit; and

FIG. 12 is a photograph of the adjustable grid for the load cells positioned under the four legs of the chair of FIG. 10.

DETAILED DESCRIPTION OF EMBODIMENTS

The apparatus of the invention comprises the combination of a chair or equivalent patient support platform such as a bed, gurney or the like with various data, audio and visual transmission components. Thus, the chair depicted in FIGS. 1 and 2, involves data sensing, collection and transmission, as well as control of sensors in the chair through the data transmission links or channels. The chair typically comprises an element of an overall system and has self-contained sensing and control elements. FIG. 4 illustrates the chair and home unit components of such a system and the invention is described in the embodiment of a chair though other platform devices may be substituted such as a bed.

FIGS. 4-9 relate to the sensor operation and examples of the information which the system may gather for the purpose of diagnosis. FIGS. 10-12 relate to a kit comprised of various sensors and diagnostic components which may be incorporated with a multitude of chair designs thereby enabling use of a typical chair in combination with a diagnostic kit and thus avoiding the cost of using a special chair for diagnostic purposes.

Referring to FIGS. 1-9, an exemplary chair with integrated sensors includes the following elements: a seat 14, a back support 16 and an optional moveable, cantilever leg support 18. The chair is mounted on four, spaced legs 20 or equivalent four mounting pads on the bottom of a chair base. Each leg 20 or mounting pad is supported on a separate load cell 22. A stable platform 23 supports the four load cells 22. The load

cells 22 on fixed support platform 23 are used to measure or indicate weight, balance, and weight distribution at any given time and as a function of time as described in more detail below. The load cells 22 preferably are positioned on the corners of a rectangle.

Back support 16 includes an array of straps 24, 26, 28 and a non-invasive blood pressure cuff strap 33. Strap 26 is an electronic stethoscope strap 26 used for assessment of heart and lung sounds and includes a respirometer used for measuring respiration data. A "safety belt" like strap 28 is used for diagnostic ECG (electrocardiogram). The "safety belt" like strap 28 is similar to the design of a safety belt used in an automobile with attached electrodes 29 to permit secure placement of the electrodes 29 in the appropriate position on a human subject for obtaining a diagnostic single, multiple or full 12 lead ECG measurement. Ancillary electrodes 29 may be provided on the other straps 24, 26.

Moveable, cantilever leg support 18 facilitates raising the legs of a patient from resting on the floor when measuring patient weight by load cells 22. A strain gage 19 in leg support 18 also allows measurement of leg muscle strength. That is, a patient may attempt to lower the support 18 by engagement with their legs. The force imparted on support 18 by such activity may be sensed by a strain gage 19 to thereby provide a measurement of leg strength, muscle condition and muscle coordination.

Arm rests or supports 30 include "finger-tip" electrodes 32, 34 used for measuring a single lead ECG lead-I and skin resistance. A hand-grip 36 is used to measure hand muscular strength and control. A skin sensor 38 is used to measure blood glucose measurements. An infra-red emitter and sensor 40 is used to measure SpO₂. An infra-red (IR) transmitter and receiver 42 is used for wireless communication to a transmission device 44 located at the patient or remote site. Communication device 44 is then linked to a central station, for example, by a wireless transmission, switched network cable line, telecommunication line or the like. An electronics enclosure 50 is attached underneath the seat 14 and contains the analog to digital conversion and microprocessor electronics for the operation of the sensor instruments in the chair.

The chair is designed so that the entire weight of the person sitting in the chair is transferred solely to the load cells 22. Thus, rectangular platform or frame 23 holds four load cells 22 arranged at the corners of the rectangular platform 23 supporting the chair. The frame 23 provides a means for physically locating the load cells 22 for supporting the chair. The frame 23 allows the load cells 22 to be fixed in each of the four corners of the rectangle or in any other desired geometric pattern associated with the legs 20 or chair support and the diagnostic protocol. Electronics which provide a common reference voltage to all load cells 22; differential amplifiers which amplify the temporal changes due to the weight shift on each load cell 22; bandpass filter for respiratory monitoring; low pass filter for human balance monitoring and a microprocessor with a multi-channel analog to digital converter are all housed in the enclosure 50. Software which controls data collection and signal processing is also incorporated in the hardware in the enclosure 50. Though the four load cells 22 are in a rectangular array, additional load cells in other arrays may be utilized to measure weight distribution as it varies with time over the surface of the seat 14 to thereby permit diagnostic measurements of the type discussed hereinafter. Each of the cells 22 provide a separate, recordable signal to the processing equipment described for ultimate transmission to a central station.

Respiration Rate Measurement

As previously described, a recliner chair is preferably used in order that support 18 will lift the feet of the patient from the floor. This is done so that all of the body weight of the patient is supported solely by the chair and the weight is directed in some pattern of distribution to each of the four sensors or load cells 22 under the chair seat 14 during measurement of respiration and other indices of patient health. That is, as a patient breathes, there is a small shift of weight from the back to the front of the chair or vice versa. This weight shift is transferred to the appropriate front and back load cells 22 in response to the shifting of patient weight due to respiration. The load cells 22 are thus arranged such that they can detect small changes in load due to patient respiratory induced weight shift. In other words, the load cells 22 are arranged so that they can detect load changes in both the X and Y directions, i.e., side to side and front to back of seat 14. As schematically depicted in FIG. 5, a high pass filter may be used to remove the DC component of the weight signal allowing only the AC changes in the signal to be passed. Since the AC changes are very small compared with the DC component, AC coupling allows the signal to be highly amplified. The signal to noise response of the system is improved by the quadrature nature of the signals. The quadrature nature of the signals arises from the fact that any increase in weight in one direction in the X-Y plane is compensated by an equal decrease in weight in the opposing direction in the X-Y plane. Noise and non-body movement artifacts thus can be removed from the signal. The front to back and side to side signal change of a sitting or recumbent subject represents respiration rate and many other physical parameters. In other words, by appropriately positioning load cells 22 and processing the AC component associated with changes in weight distribution, the system enables a physician or diagnostician located at a remote site to monitor respiration rate of the patient in real time responsive, for example, to instructed as well as natural breathing patterns. For example, the patient may have exercised before sitting in the diagnostic chair thereby enabling the diagnostician the opportunity to evaluate respiration rate following activity as well as at rest. Many variable patterns of patient activity are possible, all of which may be remotely monitored using the described system.

Weight

The lower portion of the chair acts as a scale that allows measurement of the gross weight of the patient sitting in the seat 14 of the chair. To measure total weight, the patient must raise his or her feet from the floor allowing all of the body weight to fall on the seat 14 of the chair. The DC component of the load cells signal is indicative of weight. Note, the chair may not include the cantilever leg support 18 in which event the patient must lift his or her legs from the floor to provide a true DC weight signal by the load cells 22. Also if the platform is a bed on gurney, then positioning of cells 22 will be dependent on the size of the platform and the platform will normally be supportive of leg or limb weight.

Balance

Each individual who sits down in the chair or gets up from the chair produces a characteristic response signature of time dependent weight distribution on each of the four load cells 22. The signature is used for historical reference to determine if changes in this signature may indicate physiological or pathological trauma as suggested, for example, by a change in patient ability to balance and in the response time to the command to change position (e.g., to rise from the chair) following instructions.

The monitoring of balance is accomplished by recording, for example, the transient response on the load cells 22 as a patient rises from the chair. The transient response provides a

characteristic picture signature of the shifts of body weight as a function of time when the patient rises. For example, the weight is initially transferred from the back to the front of the chair and then later to the arms 30 which provide support for the person rising from the chair. Information from the four load cells 22 over time provides a characteristic picture signature of temporal balance changes as one rises from the chair. An example of data provided for diagnostic analysis includes measurement of the movement of the center of mass of a patient over seat 14 in the X and Y directions as a function of time. Unlike respiration, the weight signals relating to changes in balance and gross weight are large signals containing the DC element. The system is designed so that the characteristic frequency of the load cells 22 is well above the upper frequency required from the system.

Periodic monitoring of a person rising from the chair produces data pattern signatures. These patterns are stored and statistically compared to new data using multidimensional statistical analysis. When the new data pattern signature is significantly different than the stored data pattern, an alarm (not shown) may be activated indicating the need for further diagnostic investigation. That alarm may be in the chair, but more appropriately is maintained at the diagnostic center.

In summary, the load cells 22 generate a myriad of data, including weight or load change as a function of time for each cell 22 as well as gross load for each cell 22 as a function of time. Preferably, this data is collected in its most basic form as analog signals by sensors 22. The signals are then typically converted to digital form by the software and hardware in the chair and transmitted by a wireless transmitter 42 to a receiver 44 at the remote site. There receiver 44 may store the data, compress the data and otherwise preliminarily process the data and subsequently forward the data via a preferred network, for example, to the central station. The data transmission may be interspersed with data or control signals to the transmitter 44. The data may thus be downloaded periodically or continually and may be processed, in part before transmission or transmitted in full.

The load cell 22 signals may be assigned to a single channel for transmission to the central station separate from the other diagnostic signals so that the interrelationship of the various diagnostic protocols may be observed. For example, weight shift data and gross weight data may interrelate with heart rate data to provide diagnostic insight. Consequently, assigning weight or load cell information to one data channel and heart rate and condition to another data channel may be optionally desired and programmed. Other diagnostic information may also be simultaneously recorded or sensed and then correlated with heart, weight distribution data, etc. Of course simultaneous audio and video interaction may also occur to facilitate the diagnostic activity.

FIGS. 6 through 9 are graphical results derived from load cell measurements of the direct current (weight parameter) of the load cells 22 in an experiment conducted to evaluate the diagnostic capacity of the device. The load cells were placed in a rectangular array with left and right back sensors or load cells 22 attached to the back legs or back edge of the chair and left and right sensors or load cells 22 attached to with the left and right front legs or front edge of the chair. Each figure depicts ten graphs which are the result of the processing of the signals from the four load cells 22. The first four graphs in the upper portion of each figure comprise or specify the absolute weights sensed by each of the sensors 22 taken during 2 second intervals. The next four graphs show differences between the pairs of adjacent sensors as indicated on the figure. The final two graphs show the summed differences of

the back, the front, and of the left to right sensors, and are indicated as delta right to left and delta back to front.

Referring first to FIG. 6 there is depicted the results with respect to a person in good general health without handicap arising from a chair in a very normal fashion. The weight of a person arising from the chair is initially shifted from the back (as sensed by the change detected by the back sensors) to the front of the chair (as detected by the front sensors) causing the rise in signal and thus the rise in weight detected in the front sensors and a corresponding decrease in the weight detected in the back sensors. Once the person has risen from the chair, of course both the front and the back sensors show a decrease and a steady state with respect to weight. In FIG. 6 it is seen that the person is risen from the chair at approximately one second. Also it is to be noted that the differential weight shift from the front to the back indicates very little difference between the left to the right sides. This indicates that the person rose from the chair in a symmetrical manner. This suggests that muscle strength and coordination is balanced and that the person rose from the chair in a normal balanced fashion relying upon the equal strength and agility with respect to muscles on both sides of the body.

FIG. 7 includes graphs quite similar to those set forth in FIG. 6. However, the events required a longer time. Approximately two seconds are required to rise from a chair in the graphs depicted in FIG. 7. Again there is little difference between the left and right sensors during the event. Thus, though the person took almost twice as long, the person arose from the chair in a very symmetrical fashion. This indicates the balance of the person is symmetrical although because of the prolonged time to rise from the chair there may be an indication of weakness or diminished strength or some other indicator of a physiological problems.

FIG. 8 indicates a person rising slowly from a chair and then momentarily falling back into the chair before completely rising. The fact that the person fell back into the chair is indicated by the bimodal peaks in the graphs. However, in this circumstance the difference between the left and right sensors is still comparable indicating that the person rose in a symmetric fashion. These charts may indicate a loss of balance, a diminution or loss of muscle strength or other physiological problems, but in any event, suggest further diagnosis in order.

FIG. 9 includes graphs or tracings that indicate that the person favors or leans to his or her left side. That is, the left side measurements increase while the right side measurements decrease. Otherwise, there is a shift from the back sensors to the front sensors as the person rises. The time period or term in order for the person to effect the movement is also somewhat prolonged. The pathophysiological indications from these charts suggest a weakness on the right side in muscle or muscle control or balance. Again, further testing and analysis are indicated.

Maintaining a record of such charts for a particular patient and comparing the charts over time will enable a practitioner to understand whether the person is maintaining a certain level of health, whether the patient is declining in health and whether, for example, therapy is assisting the patient with respect to recovery. Further charts along with norms associated with certain movements will facilitate the practitioners analysis and diagnosis.

Finger-Tip/Arm Rest ECG

Another type of data collected via the chair sensors relates to electrical sensing, most typically, ECG sensing. Thus, two electrodes 34, one mounted on the left arm 30 of the chair and one mounted in the right arm 30 of the chair, may be used to measure the standard lead one ECG vector. The use of two

electrodes **34** without a reference electrode is made possible by using an analog design incorporating a very high common mode rejection. The placement of the electrodes **34** is such that the measurement is made by the patient holding his or her arms and hands on both of the arms **30** of the chair simultaneously.

A second use of the two electrodes **34** is to provide a patient activated switch. Placing the fingers on the electrodes **34** provides one state of the switch, while removing the fingers from the electrodes **34** provides the second state of the switch. For example, the electrodes **34** of both arms **30** may require touching or activation to initiate a sequence of sensor operation. Consequently, initiation of the record of an ECG may not begin until the patient properly places fingers from each hand on separate sensors **34**. Also, the patient may be required to operate the switches **34** in a sequence or in response to an audio or video signal to diagnose sight, sound, response time or memory or attention deficit.

Alternatively, for ECG monitoring, two electrodes **34** are placed on one arm **30** of the chair and a third electrode **34** (as a ground) is placed on the other arm **30** of the chair. The input from the two electrodes **34** on the same arm can then be monitored to provide for the vector one ECG reading or signal.

Multiple other variations of electrode positioning on the arms **30** and/or belts **24**, **26**, **28** are within the scope of the invention. For example, the sensors may be placed in the back support **16** of the chair. Such placement may incorporate redundancy inasmuch as multiple sensors may be provided to sense the same feature of patient health. For example, positioning of multiple electrodes **34** on each arm for engagement by separate digits of each hand can be utilized in combination with various prescribed video and audio instructions (either preprogrammed or initiated by the central station diagnostician). This may enable detection or analysis of muscular control, memory, attention span, etc. which, in turn, provide valuable diagnostic information for detection of disease such as stroke, Alzheimer disease, etc.

Safety Belt Diagnostic ECG

The "safety belt" is a diagnostic element which, in a preferred embodiment, consists of two portions, a chest strap **26** which crosses the patient's chest from the upper right to the lower left, and a lap portion **28** which crosses the patient horizontally above the abdomen from the right side to the left side where it meets with the chest strap **26**. The straps **28**, **26** are made with an elastic material allowing initial placement of electrode pads **29** to accommodate a patient's anatomy. Electrode pads **29** are thus placed in the standard chest predefined positions used for the limb measurements of, LL and RL as well as the standard chest positions used for C1, C2, C3, C4, C5, and C6 of an ECG. The leads LA and RA are obtained from the finger-tip or arm rest electrodes **34**. The elasticity of the belt strap **28** insures good skin contact while the measurement is made. When the measurement is completed the safety belt strap **28** returns into a housing **31** mounted on the side of the chair. A full 12 lead ECG consisting of leads I, II, III, AVR, AVL, AVF, V1, V2, V3, V4, V5, V6 is derived from the input electrodes **29**.

Alternative placement of electrodes is, as suggested above, possible. Thus, the number of electrodes, their placement, their structure and construction are variable depending upon the diagnostic protocol to be adapted.

Non-Invasive Blood Pressure

A cuff **33** is used to measure non-invasive blood pressure and is stored on the side of the chair. Cuff **33** is designed for easy placement on a patient's arm. The blood pressure measurement is activated remotely after the patient slides his arm

into cuff **33**. Electronics in the chair control enclosure or housing **50** automatically monitors inflation and deflation of the cuff. Sensors in cuff **33** detect pressure and pressure change. Measurement of blood pressure may be effected separately or simultaneously with other tests described. Again, a separate data channel coordinated with other channels may be utilized in the system. Also, the data may be gathered, processed, transmitted and analyzed in the manner described above for load cell data. Other alternatives for data storage and coordination with other parameters are possible again depending upon the diagnostic protocol adopted and typically controlled from the central station.

Saturated Pulse Oximetry

Pulse oximetry is a means to confirm the amount of oxygen in the blood. Standard instrumentation uses a comparison of absorption of red and infra-red light by the body tissue to determine the percentage of oxygenated blood cells by placing a finger clip emitter/sensor **40** on patient's finger. The chair incorporates a finger clip or socket **40** located in the arm **30** of the chair. The measurement will be made by the patient placing his finger in the finger clip or socket **40**. A socket **40** may be provided in one or both arms **30**. Again, the data may be processed as described above.

Blood Glucose Analysis

Blood glucose measurements are usually made by placing a drop of blood on a chemically treated paper and recording the color of the paper. The chair has an optical sensor **38** built into the arm **30** which can measure the color of the paper. In addition, a sterilized finger prick **60** using disposable finger pricks is built into the arm **30**. A container **41** on the side of the chair is used to store finger pricks and paper, while another container **62** is used for disposing the used material. Alternatively, skin sensors can be attached to the chair to noninvasively measure blood glucose levels. The chair may also incorporate newer blood glucose measuring devices that do not require the drawing of a blood sample.

Heart and Lung Sounds

An electronic stethoscope is incorporated in strap **26** or may be attached to the side or back support **16** of the chair to assess heart and lung sounds. Alternatively, the stereoscope may be incorporated in belt or strap **26**.

Respiratory Flow Measurements

A respirometer **35** attached to the side of the chair and is used to measure pulmonary inspiratory and expiratory flow functions. Respirometer **35** may be incorporated in strap **26**.

Skin Resistance

Skin resistance is measured by placing a high frequency signal into the finger tip electrode **34** and measuring the associated resistance between the electrodes **34**.

Manual Strength Measurement

Hand grips **36** placed on one or both arms **30** with sensors are used for early detection of neurological and neuromuscular dysfunction. The grips **36** measure the active force caused by muscular contraction as well as passive sensing of finger motion associated with tremors. Similar technology is built into the leg support **18** rest for the determination of leg muscle force.

Typically, referring to FIG. 3, one embodiment of a real time hand grip monitoring device comprises a bladder **36** in the form of an ellipsoid. However, other bladder shapes may be used which are comfortable for a patient to hold or grip. The bladder **36** may be positioned and incorporated in one arm **30** or two bladders **36** may be provided, one in each arm **30**, i.e., for left hand gripping and for right hand gripping. A comparison of signals from both the left and right hand

arrangement of bladders 36 is considered important when analyzing certain muscular and neuromuscular characteristics of a patient.

The bladder 36 is connected by a tube 70 through a check valve 72 to a fluid source 74. Typically, the fluid is air, although other fluids may be utilized. The bladder 36 further includes an internal pressure sensor 76 with sending leads 77 connected thereto. The sending leads 77 connect the sensor 76 with a data recorder 78. The data recorder 78 is connected with a data comparator 80.

Typically, the bladder 36 is maintained at atmospheric pressure. When there is no manual pressure applied to the bladder 36, then there is no pressure differential with respect to atmospheric pressure. Squeezing the bladder 36 increases the pressure within the bladder 36. This pressure is sensed by the pressure sensor 76. The pressure sensor 76 produces an electrical voltage proportional to the pressure applied to the sensor which varies in time, depending upon the patient's strength and grip. The voltage contains two elements, a direct current element and an alternating current element. The direct current element represents the absolute pressure while the alternating current element represents changes in pressure associated with physiological change, for example, information relating to muscle or hand tremors.

Thus, the signal from the sensor 76 is divided into two parallel processing paths. The first path is for the direct current signal. Typically, the path will have a filter that removes the AC or alternating current portion of the signal. The second path is for the alternating current portion of the signal. This path removes the direct current portion. In each instance, after removal of the appropriate portion of the signal, by virtue of an appropriate filter, the signal is amplified. The signals are then converted into a digital format if desired and necessary by hardware and software in housing 50. The digital signals then may be transferred to a communication system as described above or processed on site and then transmitted.

In practice, it is desirable to have a bladder 36 associated with both the left hand and right hand of the patient so as to compare data with respect to both channels for the left hand and right hand side of the patient. The patient hand strength with respect to each hand provides additional physiological information, for example, associated with stroke and stroke patient recovery.

In any event, the direct current signal typically will increase to a steady state value upon manual gripping. The steady state value represents maximum hand strength. The length of time at that fixed value represents the time during which the patient can maintain the maximum hand grip force on the bladder. Integration of that fixed value represents the total energy exerted by the patient. The data is typically recorded for future comparison.

The alternating current signals are converted to an appropriate frequency where the data frequency and amplitude are recorded. Historical comparisons can then be made for the individual patient or by comparison to the standard formats or a standard library of information. Over time, the change in the readings on both channels can be determined. The differential readings with respect to left and right hand signal processing can also be determined. Thresholds can be set and an alarm can be provided which will indicate the crossing of a signal threshold. That may be indicative of a possible abnormality of the patient.

An alternative embodiment of the hand grip sensor includes a grip mechanism with load cell sensors in place of the bladder construction described. Other mechanical or electro-mechanical substitutes may be utilized to provide the AC and DC signals.

System Operation

Of course, the chair is capable of interactive use as part of a remote station/central station system as generally described in the aforementioned U.S. Pat. No. 5,544,649. However, the present invention incorporates not only sensor specific features associated with the chair, but also system features associated with the means and protocol for collecting, analyzing, transmitting, and processing data. Also, the interrelationship of the collected data is made possible for diagnostic implication. That is, conducting and measuring multiple physical parameters simultaneously at a remote site provides a better diagnostic overview of a patient and the described system permits such a diagnostic overview.

It is possible, however, to vary the function, elements and construction of the diagnostic chair and system with the chair. For example, the number of load cells 22 and their geometric array may be varied in order to enhance the data representative of factors such as weight, respiration, rate, balance, etc. Also, the chair or device may be utilized in a hospital or clinic and is not restricted to remote site use.

In operation, the patient is directed to sit in the chair and to follow a series of steps in desired and specific sequence or simultaneously. The directions are provided through the remote monitoring audio and video transmission from the central station. As depicted in FIG. 4, a video screen 51 and camera 53 are utilized in combination with the chair. As each instrument, for example, the straps 26, 28 are attached to the patient by the patient, a signal is initiated and transmitted from the transmitter receiver 42 to the transmission device 44 and then back to the central station. The electronics and logic systems in the electronics enclosure 50 control all of the initial sensing and set up and the described processing of the various signals from the patient. Thus, data manipulation is accomplished in the software and hardware and maintained in the chair or at the remote site as an initial first step. The essential data is then transmitted from the transmitter receiver to the transmission device and ultimately over some network such as a switched network to the central station. Upon completion of the examination, the patient will rise from the chair and disconnect the chair from a power source.

The platform may be in the form of a chair as described on in the form of a bed or gurney or other subject support device. Repositioning the sensors on various platforms is viewed as within the scope of the ability of a practitioner in the relevant field. The platform is also useful for detection of physical change, monitoring of subject wellness, emergency diagnosis, general health care management, rehabilitation monitoring, recovery monitoring, information collection, information dissemination, and interaction with respect to health and wellness for geriatrics especially. Examples of the utility of the device include the following.

Example 1

Congestive Heart Failure (CHF) Patients

Currently CHF patients present one of the biggest challenges of medicine. The New England Journal of Medicine reports that heart failure affects approximately 6 million Americans and is the leading cause of hospitalization for adults over the age of 65. Annual expenditures for heart failure related costs are estimated as high as \$38 billion, according to research conducted by the Journal of the American College of Cardiologists, of which \$23 billion is for hospitalizations.

Numerous studies suggest that comprehensive heart-failure-management programs can improve patients' quality of

life, reduce hospital readmissions and emergency room visits and save overall costs of treating this condition. Despite the improved results, physicians are concerned about the low level of compliance. The lack of compliance results in inaccurate data received from patients with the consequence of inappropriate treatment. The present system and device permits transmission of data such as weight, ECG, balance and coordination information etc., from the patient site to the monitoring center which will be done automatically without the need of patient activity, audio-visual verification of medication in-take, and visual contact with a health practitioner to maintain human contact.

Example 2

Diabetes

Diabetes affects 5.9% of the U.S. population, estimated to be 15.7 million Americans. Approximately half of all diabetes occurs in people older than 55. Of the 65 and older population yearly 18.4% (6.8 million people have diabetes). Diabetes causes many serious complications, including blindness, heart disease and kidney failure. One in four patients with diabetes develops foot problems which require treatment. Sixty thousand amputations are performed on people with diabetes in the U.S. each year. Complications from diabetes costs the U.S. economy \$45 billion each year, with an additional \$47 billion attributed to indirect costs from diabetes-related disabilities.

Diabetes requires daily self management. Education, frequent monitoring and medication adjustments in the home setting with the disclosed device will help patients achieve better glucose and blood pressure control, thereby preventing or slowing the progression of diabetes complications, provide psychological support achieved by audio-visual interaction with a nurse, and provide the capability of monitoring and retrieving various vital signs (i.e., ECG, NIBP, weight) and clinical observations (i.e., wounds, swelling, etc.) and to prevent complications such as cardiac problems and circulatory problems leading to amputation, stroke, etc.

Example 3

Parkinson's Disease

Parkinson's disease is a progressive disorder of the central nervous system affecting approximately 2 out of 1,000 people, and most often develops after age 50. It is one of the most common neurological disorders of the elderly. Treatment begun early in the disorder can slow progression of the disease.

The health care provider may be able to diagnose Parkinson's disease based on the symptoms and physical examination. However, the symptoms may be difficult to assess, particularly in the elderly. Some of these symptoms are: muscle rigidity, stiffness, difficult bending arms and legs, unstable, or slumped-over posture, loss of balance, gait changes, shuffling walk slow movements, difficulty beginning to walk, difficulty in initiating any voluntary movement, small steps followed by the need to run to maintain balance, freezing of movement when the movement is stopped, inability to resume movement, shaking and tremor, changes in facial expression.

Some of these symptoms are not specific to Parkinson and may be confused with other disorders that cause similar symptoms. For example, the posture changes may be similar to osteoporosis or other changes associated with aging. Lack

of facial expression may be a sign of depression. The tremor may not appear when the person is sitting quietly with arms in the lap.

Untreated, the disorder progresses to total disability, often accompanied by general deterioration of all brain functions. It may result in an early death if untreated.

Treated, the disorder impairs people in varying ways. Most people respond (to some extent) to medications. The extent of symptom relief, and how long this control of symptoms lasts, is highly variable. The side effects of medications may be severe. The device with its response time test and the ability to detect and measure tremors will enable the early detection of the disease as well as the follow up of the efficacy of the medications.

The type and number of tests which can be implemented utilizing the chair or an alternative platform may be varied. All of the tests described need not be performed. Various additional tests may be incorporated into the chair using additional types of sensors. Also, the chair (device) may be automatically controlled from a remote (or near) station to automatically perform a series of tests without a nurse or professional guiding the subject. The system can therefore be programmed to conduct testing upon initiation by the subject of a predefined protocol. The test results will then be transmitted and/or recorded for later personal review.

FIGS. 10, 11 and 12 illustrate an embodiment of the invention wherein a kit is provided for use in combination with a chair 100 having a size, shape or design. More specifically, the kit is comprised of a grid 106 which may be placed upon a floor or a other horizontal flat surface. A standard chair may then be positioned upon the grid 106 and, more particularly, upon load cells incorporated in the grid 106. Covers 108, 110 for the arms of the chair 100 include various sensors and pockets for instrumentation for diagnostic purposes. A head rest 122 is provided and straps 126 are included for attachment thereof to the back 124 of the chair 100. The backside of the head rest includes various electronic gear 120 for gathering and processing and forwarding the sensed diagnostic information from a patient sitting or reclining in the standard chair 100. Thus FIG. 10 is a photograph depicting the standard chair 100 having four legs. Chair 100 includes legs such as legs 102 and 104. The legs 102, 104 are spaced one from each other in a generally rectangular pattern. A grid assembly 106 shown in greater detail in FIG. 12 is adjusted to position load sensors under each of the respective legs 102 and 104 as well as the legs (see FIG. 11) of the opposite side of the chair 100.

Arm covers 108 and 110 are positioned respectively over the arms 112 and 114 of the chair 100. The arm covers 108 and 110 include various sensor pads such as pad 116. The sensors, such as the sensor pad 116, are designed to sense aspects of diagnostic information such as heart rate, blood pressure and the like. The cover 110 includes a pocket for additional instrumentation. Further, a storage pocket 118 may be associated with e.g. arm cover 100. A similar assembly may be provided with the arm cover 108.

Wireless sensors may be provided to transmit detected diagnostic information to a telemetry collection and transmission packet 120 supported by the back side of the head rest 122 which is maintained on the chair back 124 by a strap 126. All of the diagnostic information gathered using the kit may then be transmitted in a manner similar to the telemetry and transmission system previously described with respect to FIGS. 1-9.

As shown in FIG. 11, which is the opposite side of the chair 100 of FIG. 10, the arm cover 108 may be hard wired through a connection 125 to the telemetry transmission packet 120.

15

FIG. 11 also depicts the legs 107 and 109 on the opposite side of the chair 100. The grid 106 which is designed to support the legs of the chair 100 is shown so that it is positioned in a manner wherein load cells are beneath each of the legs of the chair 100.

FIG. 12 depicts the in a plan view the grid 106 construction for the load cells. Four load cells 132, 134, 136 and 138 are positioned on a grid 106 comprised of plates such as plate 140. In other words, a load cell is associated with each plate 140. The plates 140 are connected by a telescoping rod 144 in a tube 145. The rods 144 may be adjusted to space the load cells and more particularly the plates 140 upon which the load cells 132, 134, 136 and 138 are positioned. In this manner, the grid may be adjusted so as to position the load cells beneath the legs of any chair. Leads such as lead 150 connect each load cell to the telemetry packet or station 120. The adjustability of the load cells as well as the portability of the other component portions of the kit enable the utilization of the diagnostic techniques described with respect to FIGS. 1-9 in combination with any seating arrangement or chair. The cost savings and portability of the system is thus significantly enhanced.

While there has been set forth various embodiments of the invention, it is understood that the invention will be limited only by the following claims and the equivalents thereof.

What is claimed is:

1. A medical examination diagnostic device in the form of a kit for a chair comprising:

a horizontal chair seat member for accommodation of a seated patient on a chair;

at least four chair seat support members located respectively at the corners of a quadrilateral support for said seat member, said seat member having a front edge and a back edge, two of said support members aligned with the back edge and two of said support members aligned with the front edge;

a frame connecting said support members by adjustable links;

an independent load sensor device located under each of said seat support members, each said load sensor device configured for detecting the load independently on each of load sensor device to provide a set of four independent data signals for medical diagnosis;

a data collection device for collecting said independent data signals;

a processor that measures and records the collected signals as a function of time corresponding to a weight distribution of a patient sitting on the horizontal chair seat member, said processor configured to provide an indi-

16

cation of each one of the data signals as a change characterized by a temporally sequential relationship among said four independent recorded data signals wherein said indication is selected from the group consisting of at least one of the following:

a diagnostic respiration rate;

a physiological trauma; and

a pathological trauma; and

wherein each load cell is mounted on a plate, said plates being connected to form a quadrilateral grid with a load cell mounted at each corner of said grid, the distance between each plate being adjustable, each load cell being independently connected to said processor.

2. The chair kit of claim 1 further including at least two arm pads incorporating one or more sensor elements, and one or more of the following supplemental sensor elements located in at least one of said sensor pads:

blood pressure sensor;

pulse oximetry sensor;

sound sensor;

skin resistance sensor;

manual grip sensor;

fluid flow rate sensor;

glucometer.

3. The chair kit of claim 1 further including a wireless sensor signal collection, storage and transmission device for attachment to a chair, said wireless sensor signal collection, storage and transmission device for collection of sensor signals from said sensor devices.

4. The chair kit of claim 1 wherein adjacent plates are connected by a link comprised of a telescoping rod in a tube, said links forming said quadrilateral grid.

5. The chair kit of claim 1 for placement upon a chair having arm rests and a back support, said kit further including sensor pads for placement on the arm rests and back support, each sensor pad including independent sensor elements and a signal transmission device for transmission of a data signal to said processor.

6. The chair kit of claim 1 further including at least one arm pad incorporating one or more supplemental sensor elements located in said sensor pad for sensing diagnostic information from a patient sitting or reclining in a chair.

7. The chair kit of claim 1 for placement upon a chair having a back support, said kit further including a sensor pad for placement on said back support including one or more sensor elements for sensing diagnostic information from a patient sitting or reclining in a chair.

* * * * *

专利名称(译)	用于与椅子组合的医疗传感器套件，用于测量诊断信息		
公开(公告)号	US8469884	公开(公告)日	2013-06-25
申请号	US13/540276	申请日	2012-07-02
[标]申请(专利权)人(译)	COMMWELL RES和DEV LTD以色列		
申请(专利权)人(译)	commwell研发，公司卡法萨巴公司，以色列		
当前申请(专利权)人(译)	commwell研发有限公司		
[标]发明人	DAVID DANIEL LEVY IRVING		
发明人	DAVID, DANIEL LEVY, IRVING		
IPC分类号	A61B5/00 A61B19/00 A47C7/62 A47C31/00 A61B5/0205 A61B5/022 A61B5/0408 A61B5/053 A61B5/08 A61B5/087 A61B5/103 A61B7/04		
CPC分类号	A61B5/0205 A61B5/04085 A61B5/1036 A61B5/14532 A61B5/6887 A61B5/6891 A61B7/04 A61B5/225 A61B5/14551 A61B5/0026 A61B5/7278 A61B5/0002 A61B5/02241 A61B5/0531 A61B5/0816 A61B5/087 A61B5/1455		
代理机构(译)	BANNER & WITCOFF., LTD.		
优先权	10/276455 2002-11-18 US PCT/US2001/016360 2001-05-18 WO 61/160135 2009-03-13 US 60/232708 2000-09-15 US 60/205369 2000-05-18 US 60/205144 2000-05-18 US		
其他公开文献	US20120271122A1		
外部链接	Espacenet USPTO		

摘要(译)

医疗检查椅套件包括一组传感器，包括指尖传感器中的电极，可安装或可放置在椅子上的盖子中的各种其他类型的传感器以及支撑椅子的可调节网格上的称重传感器，所有这些都提供数据。在安装在椅子上的传动袋中进行部分处理。

