



(19) **United States**

(12) **Patent Application Publication**
Sevick-Muraca et al.

(10) **Pub. No.: US 2005/0085732 A1**

(43) **Pub. Date: Apr. 21, 2005**

(54) **METHOD AND SYSTEM FOR NEAR-INFRARED FLUORESCENCE CONTRAST-ENHANCED IMAGING WITH AREA ILLUMINATION AND AREA DETECTION**

Related U.S. Application Data

(60) Provisional application No. 60/480,526, filed on Jun. 20, 2003.

Publication Classification

(51) **Int. Cl.⁷** **A61B 6/00**
(52) **U.S. Cl.** **600/473**

(76) **Inventors:** **Eva M. Sevick-Muraca**, College Station, TX (US); **Alan B. Thompson**, Hillsboro, OR (US); **Roy Ranadhir**, College Station, TX (US)

(57) **ABSTRACT**

According to one embodiment of the invention, a method for biomedical imaging includes directing time-varying excitation light at a surface area of a light scattering material, the material comprising a fluorescent target. Time-varying emission light from the fluorescent target is detected, substantially at a two-dimensional sensor surface, in response to the time-varying excitation light stimulating the fluorescent target. The time-varying emission light is filtered to reject excitation light re-emitted from the material. A three-dimensional image of the fluorescent target is generated based on the detection substantially at the sensor surface.

Correspondence Address:
BAKER BOTTS L.L.P.
2001 ROSS AVENUE
SUITE 600
DALLAS, TX 75201-2980 (US)

(21) Appl. No.: **10/872,333**

(22) Filed: **Jun. 18, 2004**

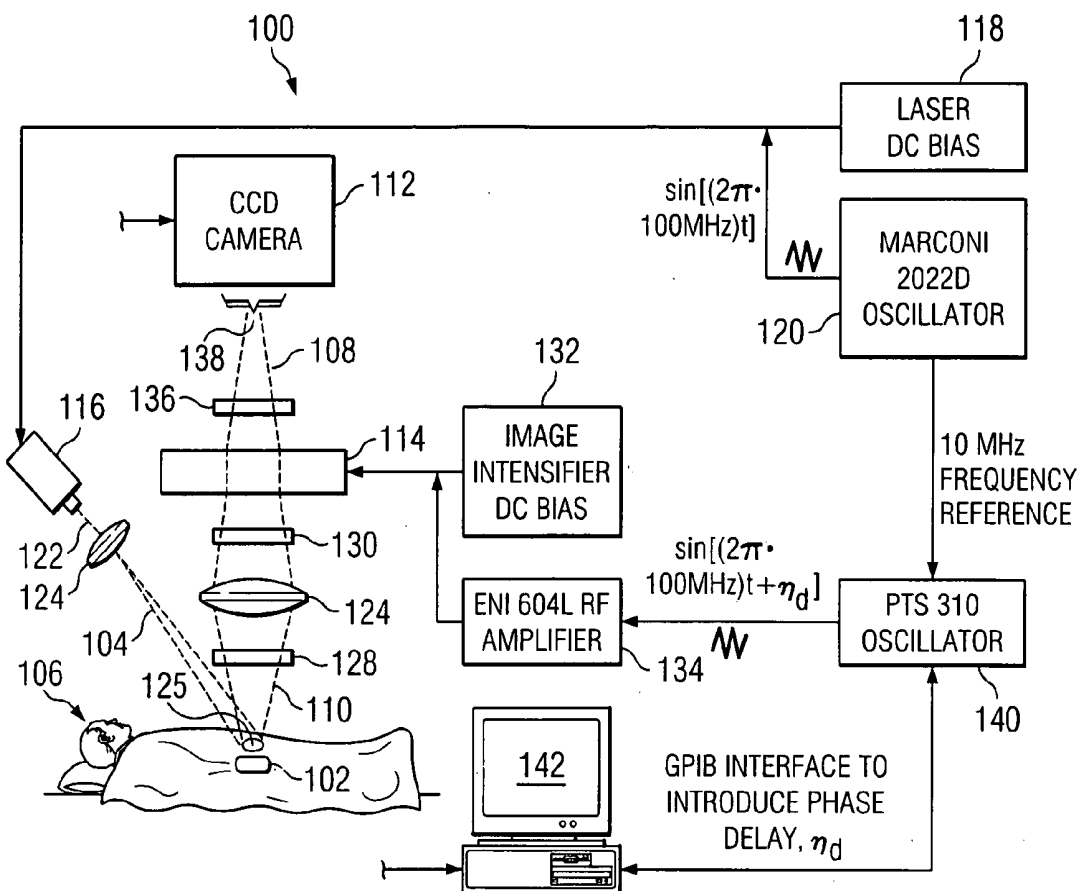

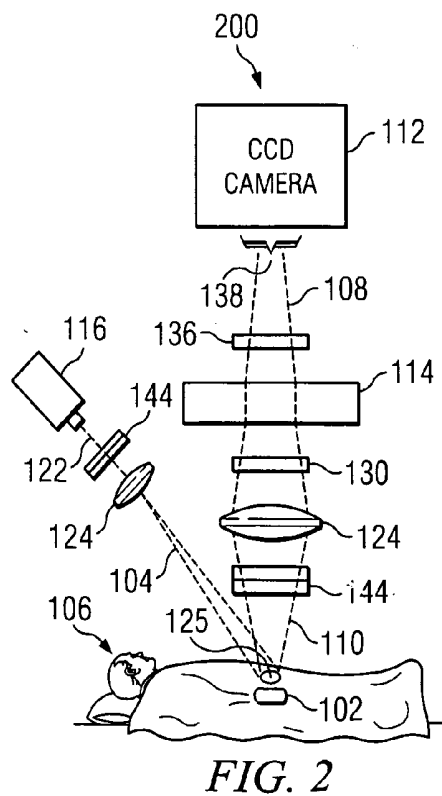
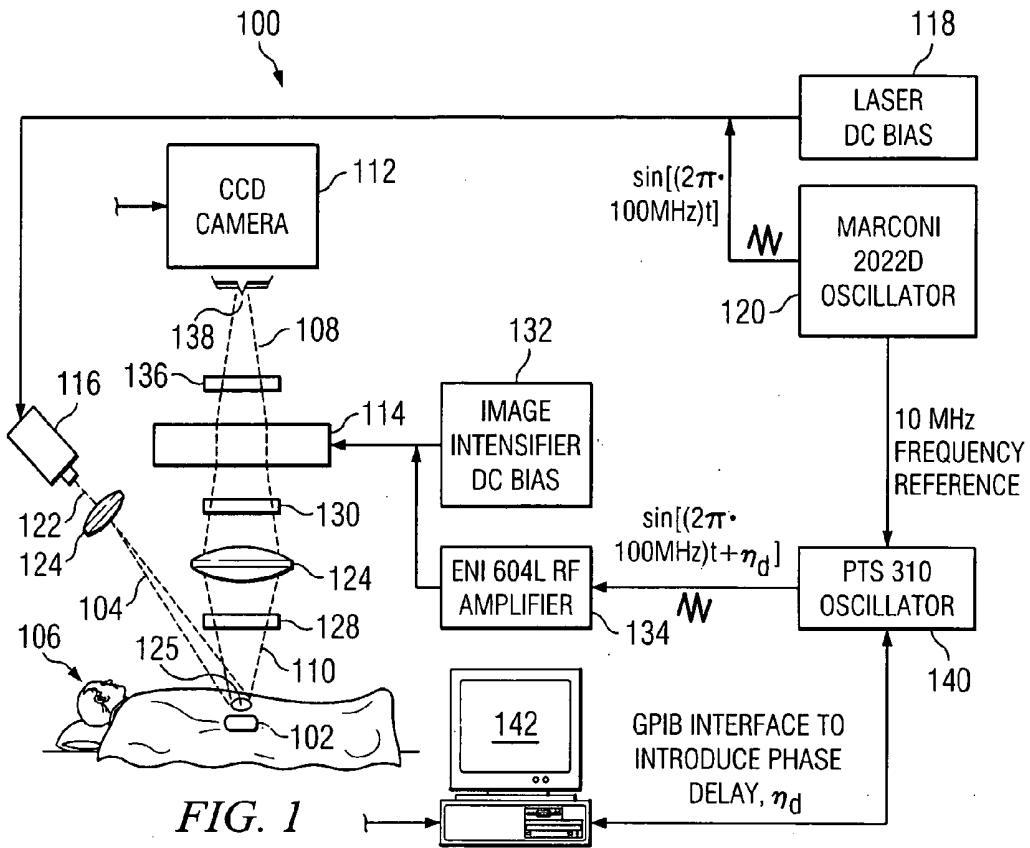

FIG. 3

300

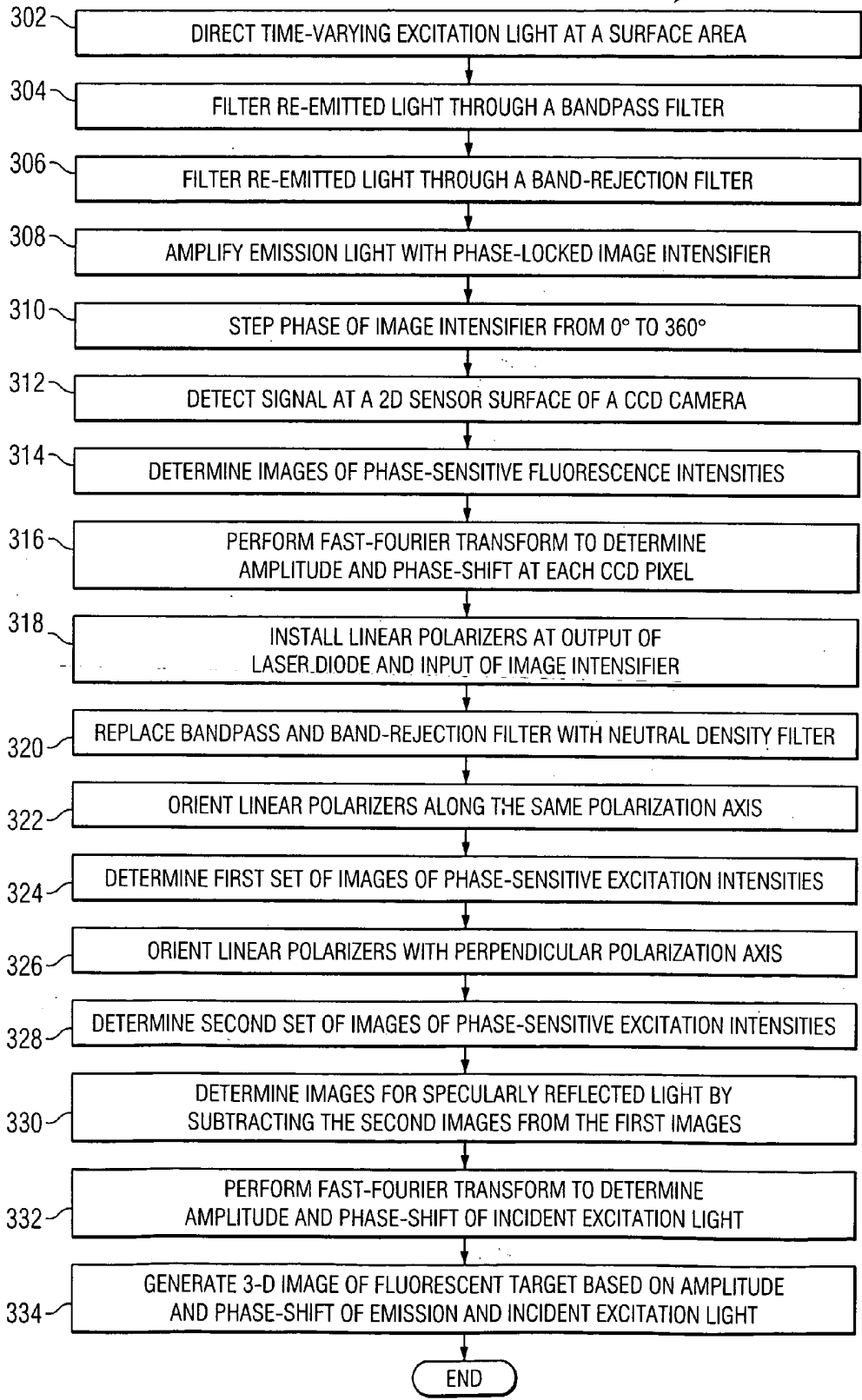

FIG. 4

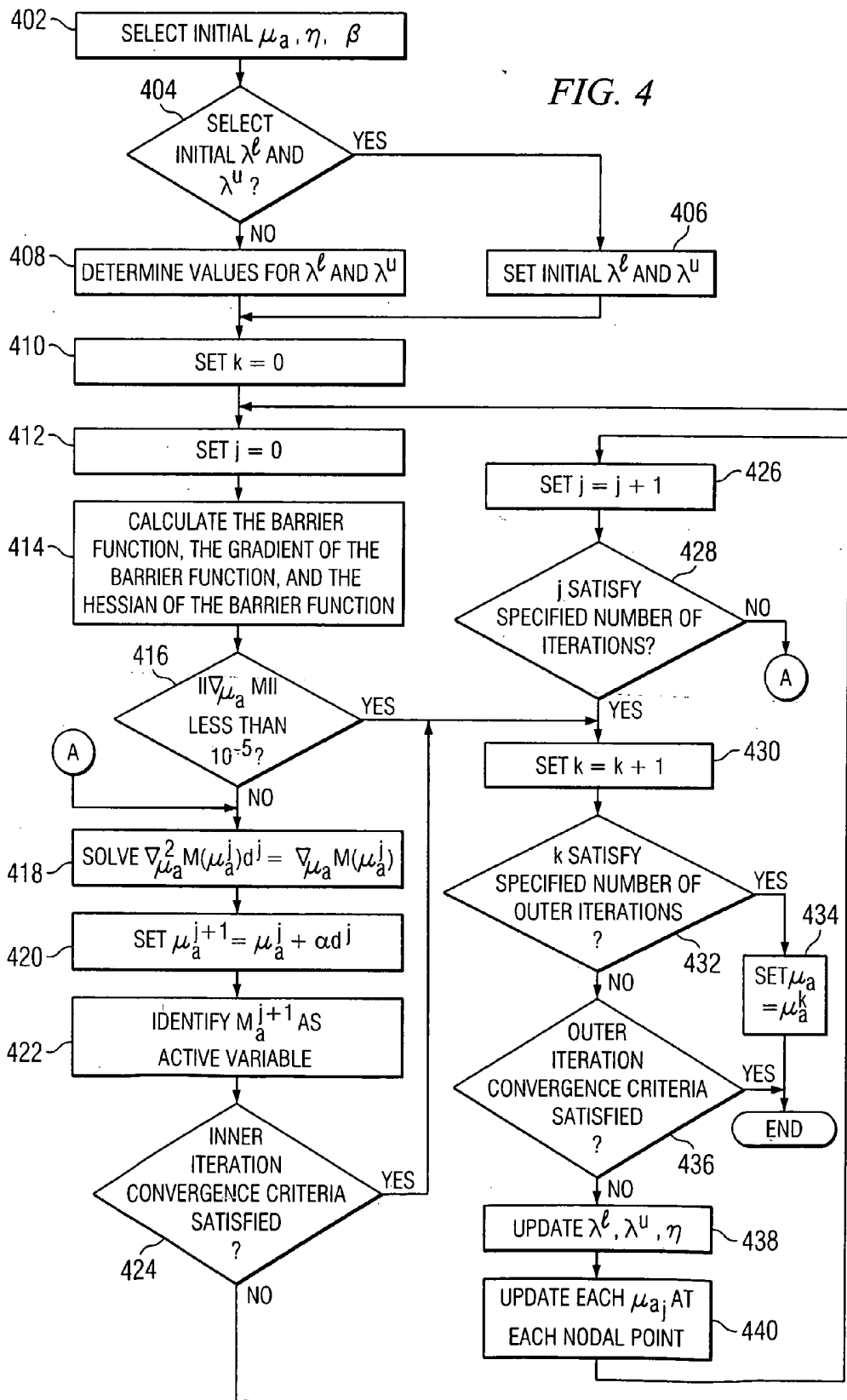

FIG. 5A

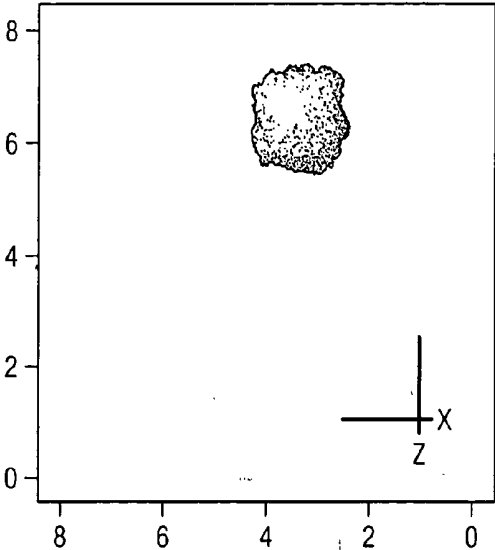

FIG. 5B

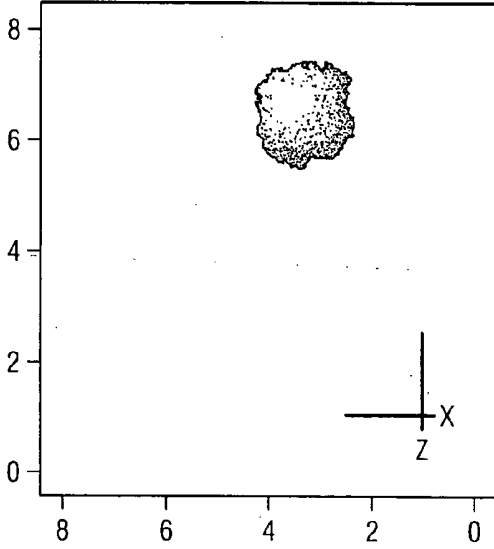
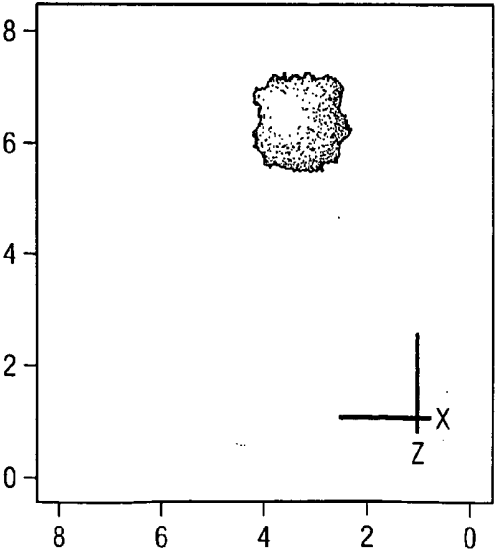

FIG. 5C



**METHOD AND SYSTEM FOR NEAR-INFRARED
FLUORESCENCE CONTRAST-ENHANCED
IMAGING WITH AREA ILLUMINATION AND
AREA DETECTION**

BACKGROUND OF THE INVENTION

[0001] Fluorescent contrast agents have been developed and/or employed that enhance the optical detection of diseased tissues. These agents excite and re-emit at near-infrared (NIR) wavelengths, which deeply penetrate tissues. Localization of a contrast-enhanced target in three dimensions necessitates: (1) rapid and precise acquisition of fluorescence measurements; (2) accurate prediction of these measurements using an appropriate theoretical model of light propagation through tissues; and (3) tomographic reconstruction of model parameters, which include optical and fluorescent properties of tissues, using an optimization routine that minimizes the differences between the experimental and predicted fluorescence data. Steady-state and time-resolved experimental measurements of diffuse fluorescence have been used to localize a contrast-enhanced target. The steady-state measurements provide information regarding the spatial origin of fluorescent photons, and the time-resolved measurements provide additional information regarding fluorescence decay kinetics, which may render functional information about the environment in which the fluorophores reside.

[0002] Experimental measurements of diffuse fluorescence acquired using point illumination and point detection techniques have been incorporated into tomographic reconstruction algorithms. In order to adequately probe a tissue volume using these techniques, illumination and detection must occur via fiber optic at several points about the tissue volume. Disadvantages with point illumination and point detection include (1) possible failure to sufficiently excite the contrast-enhanced target and (2) the production of sparse data sets, which make the underdetermined inverse problem difficult to solve.

SUMMARY OF THE INVENTION

[0003] A method and system for near-infrared fluorescence contrast-enhanced imaging with area illumination and area detection are provided. In one embodiment, a method for biomedical imaging includes directing time-varying excitation light at a surface area of a light scattering material, the material comprising a fluorescent target. Time-varying emission light from the fluorescent target is detected, substantially at a two-dimensional sensor surface, in response to the time-varying excitation light stimulating the fluorescent target. The time-varying emission light is filtered to reject excitation light re-emitted from the material. A three-dimensional image of the fluorescent target is generated based on the detection substantially at the sensor surface.

[0004] Embodiments of the invention provide a number of technical advantages. Embodiments of the invention may include all, some, or none of these advantages. An approach employed herein involves area illumination and area detection on the same tissue-like surface. This approach overcomes the disadvantages associated with point illumination and point detection given that (1) fluorophores within a large tissue volume are more efficiently excited via area illumina-

tion and (2) significantly more data is provided via area detection. In addition, non-contact imaging is possible. Some applications may arise in medical imaging of diseased tissues and intraoperative 3D identification of diseased (and tumor) lesion margin for effective and complete resection of diseased tissue, among others.

[0005] Other advantages may be readily ascertainable by those skilled in the art from the following figures, description, and claims.

BRIEF DESCRIPTION OF THE DRAWINGS

[0006] For a more complete understanding of the invention, and for further features and advantages, reference is now made to the following description, taken in conjunction with the accompanying drawings, in which:

[0007] **FIG. 1** is a schematic illustrating a system for near-infrared ("NIR") frequency-domain photon migration ("FDPM") measurements according to one embodiment of the present invention;

[0008] **FIG. 2** is a schematic illustrating a system for detecting re-emitted excitation light in accordance with one embodiment of the present invention;

[0009] **FIG. 3** is a flow chart illustrating a method for tomographic fluorescent imaging in accordance with one embodiment of the present invention;

[0010] **FIG. 4** illustrates one embodiment of generation step of **FIG. 3**; and

[0011] **FIGS. 5A-C** illustrate a reconstructed three-dimensional image of a fluorescent target.

**DETAILED DESCRIPTION OF EXAMPLE
EMBODIMENTS OF THE INVENTION**

[0012] **FIG. 1** is a schematic illustrating a system for excitation area illumination and area detection using near-infrared ("NIR") frequency-domain photon migration ("FDPM") imaging techniques according to one embodiment of the present invention. In particular, system **100** generates three-dimensional ("3D") images of fluorescent target **102** within a light scattering material (e.g., tissue) based on emission light detected at a two-dimensional ("2D") sensor surface. At a high level, system **100** delivers an intensity-modulated excitation light **104** into the tissue of a body **106** to cause stimulated emission of fluorescent target **102**. Emission light **108** from the fluorescent target **102** is detected by intensified charge-coupled camera (ICCD) **112** via gain modulated image intensifier **114**. A 3D image of fluorescent target **102** is generated based, at least in part, on excitation light **104** and emission light **108**. System **100** provides several advantages over the prior art such as, for example, the ability to reconstruct a 3D image from data collected at a 2D surface with contact. The present invention contemplates more, less, or different components than those shown in system **100** of **FIG. 1**.

[0013] Referring to **FIG. 1**, system **100** includes a laser diode **116** coupled to a laser DC bias **118** and a reference frequency generator **120**. As a result, laser diode **116** generates light source **122**, intensity-modulated excitation light. In one embodiment, light source **122** comprises 785-nanometer ("nm") excitation light provided by a 70-milliWatt ("mW") laser diode **116**. Additionally, a temperature con-

troller (not illustrated) may be included in system 100 to assist in maintaining the optical power and the wavelength of laser diode 116; however, other suitable wavelengths and sources may be used. Light source 122 may comprise other suitable NIR light such as, for example, 700-nm to 900-nm light. Light source 122 passes through lens 124A to produce an expanded beam of excitation light 104 for illuminating a surface area 126 of body 106. Surface area 126, in one embodiment, is approximately 9 centimeters squared (cm^2) in size. Surface area 126 may comprise other suitable areas ranging from 1 cm^2 to 100 cm^2 . Surface area 126 is illuminated with excitation light 104 for stimulating fluorescent target 102. Fluorescent target 102 comprises a fluorescent contrast agent (e.g., Indocyanine Green (“ICG”)) that emits light in response to excitation light 104. In one embodiment, ICG is excited at 780 nm and emits at 830 nm, has an extinction coefficient of $130,000 \text{ M}^{-1}\text{cm}^{-1}$, a fluorescent lifetime of 0.56 ns and a quantum efficiency of 0.016 for the 780/830 nm excitation/emission wavelengths. After illuminating surface area 126, light is re-emitted from body 106.

[0014] Re-emitted light 110 includes emission light 108 and reflected excitation light. To minimize the excitation light delivered to image intensifier 114, a band-pass filter 128 centered around the emission wavelength and a band-rejection filter 130 centered around the excitation wavelength are used in combination to substantially reject the excitation wavelength from re-emitted light 110 to provide emission light 108. Emission light 108 substantially comprises light emitted by fluorescent target 102 as a result of excitation light 104 stimulating fluorescent target 102. Band-pass filter 128 and band-rejection filter 130 may be coupled via lens 124B (e.g., 50-mm lens). In one embodiment, band-pass filter 128 and band-rejection filter 130 comprise an 830-nm image quality bandpass interference filter and a 785-nm holographic band-rejection filter, respectively. Alternatively, system 100 may use any suitable combination of filters such as, for example band-pass filters, long-pass filters, holographic notch filters, band-rejection filters or any combination thereof, or any optical scheme to reject the excitation wavelength enabling registration of the emission wavelength. After the combined filters substantially remove the excitation wavelength, emission light 108 is amplified by image intensifier 114.

[0015] In one embodiment, image intensifier 114 includes a photocathode face that converts photons to electrons, a multi-channel plate (“MCP”) that multiplies the electronic signal by avalanche multiplication, and a phosphorescent screen that converts electrons into an optical image. In one embodiment, image intensifier 114 is a fast intensifier of the variety manufactured by Litton Electronics, Inc., which enables modulation by applying a DC bias via image intensifier bias 132 and an RF signal via an RF amplifier 134 between the photocathode and the MCP; however, other suitable image intensifiers may be utilized. In the illustrated embodiment, the intensifier gain of image intensifier 114 and the intensity of excitation light 104 are phase-locked by a 10 MHz reference signal provided by oscillator 120. By modulating laser diode 116 and image intensifier 114 at the same frequency, homodyning results in a steady-state image on the phosphor screen. The image from the phosphor screen is focused through a lens 124C (e.g., 105-mm lens) onto a two-dimensional sensor surface 138 of camera 112, in order to provide area detection. As used herein, the term “two-dimensional sensor surface” means a substantially two-

dimensional surface determined by the sensors of camera 112. Sensor surface 138 may be flat, curved, bent, or arranged in any suitable surface. In one embodiment, sensor surface 138 comprises a 16 cm^2 flat surface. Camera 112, in the illustrated embodiment, has a 512×512 array of CCD detectors configured to provide a corresponding pixelated image.

[0016] In operation, following each acquired image, a phase delay between image intensifier 114 and laser diode 116 is induced by stepping the phase of image intensifier 114 between 0 and 360° relative to the phase of laser diode 116 modulation. Preferably, control between oscillator 140 and the processor is obtained by a conventional general purpose interface bus (“GPIB”) 142; however, other suitable interfaces may be utilized. Images from the phosphorescent screen image intensifier 114 may then be gathered at each phase delay by camera 112 to determine phase-sensitive fluorescence intensity. In one embodiment, each image, may contain 128×128 pixels of intensity counts and be acquired by use of a 0.4-s CCD exposure time. A fast Fourier transform of the phase-sensitive fluorescence intensities acquired at each CCD pixel may be performed to compute the amplitude and phase-shift of excitation light 108 at each CCD pixel. Prior to generating a 3D image of fluorescent target 102 based on the amplitude and phase-shift of emission light 108, the predicted amplitude and phase-shift of emission light 108 may be determined by the coupled frequency-domain diffusion equations (1) and (2) discussed below; however, the amplitude and phase may be determined by any other suitable mathematical model of light propagation. However, the solution to these coupled equations require the spatial distribution of amplitude and phase-shift of incident excitation light 104. Since it is difficult to create an excitation beam 104 of intensity-modulated excitation light that is spatially uniform in both amplitude and phase-shift, the spatial distribution of excitation light 104 may be experimentally determined.

[0017] In one embodiment, system 100 may be altered to experimentally determine the amplitude and phase-shift of incident excitation light 104 in the following manner: (1) linear polarizers 144 are positioned at the output of laser diode 116 and the input of CCD camera 112; (2) aperture of lens 124 may be minimized; and (3) bandpass filter 128 and band-rejection filter 130 are replaced with a neutral density filter 146 to provide system 200 illustrated in FIG. 2. Generally, re-emitted light 110 includes both specularly (or singly) reflected excitation light and multiply reflected excitation light. Since singly reflected excitation light may be representative of incident excitation light 104, re-emitted light 110 is compared to multiply-reflected excitation light to determine the spatial distribution of the singly reflected excitation light and thus the spatial distribution of incident excitation light 104.

[0018] In one aspect of operation, the polarization angle of linear polarizers 144 are first oriented parallel to one another to predominately detect specularly reflected excitation light. Images of phase-sensitive excitation light intensity of this detect light may be determined using the procedure described above with regard to FIG. 1, predominantly resulting in images representative of specularly reflected excitation light. In order to substantially remove multiply scattered excitation light intensities from these images, the polarization angles of linear polarizers 144 may be adjusted

to determined images of phase-sensitive excitation light intensity for multiply reflected light. In general, linearly polarized light incident on a tissue surface and multiply reflected by fluorescent target **102** reemerges from the tissue depolarized with equal probability of having a polarization angle parallel or perpendicular to incident polarization angle. Therefore, to substantially remove image intensities representative of multiply reflected excitation light from the images of phase-sensitive excitation light intensity, a second set of images of phase-sensitive excitation light intensity representative of multiply reflected excitation light may be acquired after orientating the polarization angles of polarizer **144** perpendicular to one another. The second set of images may be subtracted from the first set of images to provide phase-sensitive excitation light intensity of the specularly reflected excitation light. Afterward, a fast Fourier transform of the phase-sensitive images representative of the specularly reflected excitation light may be performed to determine the spatial distribution of the amplitude and phase of incident excitation light **104**. Once the spatial distribution of both incident excitation light **104** and emission light **108** are determined, the mathematical expression discussed in relation to **FIG. 4** may be used to iteratively converge upon the optical properties of fluorescent target **102**.

[0019] **FIG. 3** is an example flow diagram illustrating a method **300** for generating a 3D image from light detected on a two-dimensional sensor surface. Method **300** is described with respect to system **100** and **200** of **FIGS. 1 and 2**, respectively, but method **300** could also be used by any other system. Moreover, system **100** and **200** may use any other suitable techniques for performing these tasks. Thus, many of the steps in this flow chart may take place simultaneously and/or in different orders as shown. Moreover, system **100** and **200** may use methods with additional steps, fewer steps, and/or different steps, so long as the methods remain appropriate.

[0020] At a high level, method **300** illustrates two processes for generating a 3D image: an emission-light process and an incident-light determination process. The emission-light determination process is illustrated in steps **302** to **316**, and the incident-light determination step is illustrated in steps **318** to **332**. Method **300** begins at step **302** where a time-varying excitation light **104** is directed at a surface area **126** of body **106** to stimulate fluorescent target **102**. Next, at step **304**, re-emitted light **110** from body **106** is filtered by band-pass filter **128** to pass a subband of re-emitted light **110** including the emission wavelength to band-rejection filter **130** while substantially rejecting other wavelengths. Band-rejection filter **130** rejects a subband of the received light, including the excitation wavelength, and passes emission light **108** to image intensifier **114** at step **306**. At step **308**, image intensifier **132** is phase-locked to laser diode **116** and amplifies emission light **108**. In order to determine phase-shift data for emission light **108**, image intensifier **132** is stepped between 0° and 360° relative to the phase of laser diode modulation at step **310**. Next, at step **312**, the amplified emission light **108** is detected at a two-dimensional surface area **138** of CCD camera **112** to electronically recover intensity data of emission light **108**. Images of phase-sensitive fluorescence intensities is determined for each CCD pixel at step **314**. At step **316**, a fast Fourier transform of the phase-sensitive fluorescence intensities is performed to compute spatial distribution of the fluorescence intensity and phase-shift for each CCD pixel. In short,

system **100** has now experimentally determined the spatial distribution of emission light **108** and is ready to determine the spatial distribution of incident excitation light **104**.

[0021] The excitation-light determination step begins at step **318** where linear polarizers **144** are installed at the output of laser diode **116** and the input of image intensifier **114**. Next, at step **320**, bandpass rejection filter **128** and band-rejection filter **130** are replaced with neutral density filter **146**. In order to determine the spatial distribution for excitation light, the polarization axis of linear polarizers **144** are aligned along the same axis at step **322**. A first set of images of phase-sensitive excitation intensities is determined at step **324**, which predominantly represents specularly reflected excitation light. At step **326**, linear polarizers **144** are aligned with their polarization axis substantially perpendicular to detect multiply scattered excitation light. A second set of images of phase-sensitive excitation intensities is determined at step **328**, which predominantly represents multiply reflected excitation light. In order to substantially remove multiply reflected excitation intensities from the first set of images, the second set of images is subtracted from the first set of images to determine images of phase-sensitive excitation intensities for specularly reflected excitation light at step **330**. Since specularly reflected excitation light is representative of incident excitation light **104**, a fast Fourier transform of the images of phase-sensitive excitation intensities for specularly reflected excitation light computes the spatial distribution of excitation intensity and phase-shift for incident excitation light **104** at step **332**. Finally, at step **334**, a 3D image of fluorescent target **102** is generated based on the spatial distribution of intensity and phase-shift for incident excitation light **104** and emission light **108**. **FIG. 4** illustrates one embodiment of determining the 3D image corresponding to step **334** above, in accordance with the penalty/modified barrier function (PMBF) method.

[0022] **FIG. 4** illustrates one embodiment of step **334** of **FIG. 3** for generating a 3D image of fluorescence absorption coefficients. Method **400** is described with respect to system **100** and **200** of **FIGS. 1 and 2**, respectively, but method **400** could also be used by any other system. Moreover, system **100** and **200** may use any other suitable techniques for performing these tasks. Thus, many of the steps in this flow chart may take place simultaneously and/or in different orders as shown. Moreover, system **100** and **200** may use methods with additional steps, fewer steps, and/or different steps to generate a 3D image of fluorescence absorption coefficients.

[0023] To aid in understanding the various mathematical aspects of method **400**, the following tables of selected variables is listed:

\vec{r}	position
c	speed of light
S	source
n	number of nodal points
ω	angular modulation frequency
$\mu_{a_{xi}}$	absorption coefficient due to chromophore
$\mu_{a_{xf}}$	absorption coefficient due to fluorophore
μ_a	total absorption at the emission wavelength is equal to the absorption owing to nonfluorescent chromophores $\mu_{a_{xi}}$ and fluorescent chromophore, $\mu_{a_{mf}}$

-continued

D	optical diffusion coefficient = $\frac{1}{3}[\mu_{a,x,m} + \mu'_{s,x,m}]$
$\mu'_{s,x,m}$	isotropic scattering coefficient
$\mu_{a,x,m}$	total absorption coefficient
Φ	complex fluence
ϕ	quantum efficiency
τ	fluorescence lifetime
Ω	volume
I_{AC}	intensity amplitude
θ	phase-shift
K	global stiffness matrices
b	global vector in FEM stiffness equation containing source terms
E	error function
N_D	number of detectors
N_S	number of source
g	gradient vector ∇E
d	Newton direction
α	step length
H	Hessian matrix $\nabla^2 E$
l	lower bound of the absorption coefficient owing to fluorophore
u	upper bound of the absorption coefficient owing to fluorophore
L^1	Natural coordinate
$B(\mu_a)$	active set (lower bound)
$B'(\mu_a)$	active set (upper bound)
$C(\mu_a)$	free variable set
ϵ	tolerance of lower and upper bound
λ	Lagrange multipliers
λ^l	Lagrange multiplies for lower bound
λ^u	Lagrange multipliers for upper bound
M	modified barrier penalty function
$h_i(\mu_a)$	bound constrain
$f(h_i(\mu_a))$	quadratic penalty/barrier term of PMBF
$\phi(h_i(\mu_a))$	quadratic extrapolation method
S_i	shifting parameter
η	barrier parameter
β	parameter defines how close the extrapolation will get to singularities of logarithm term
q_1^1, q_1^2, q_1^3	coefficient of the quadratic function
γ	reduction factor of the barrier parameter
k	outer iteration number
j	inner iteration number
$\gamma_1^k, \gamma_2^k, d_1$ and d_2	convergence criteria
ϵ_1	reconstruction error

[0024] Generally, method 400 uses the modified barrier penalty function to reconstruct a 3D image of fluorescence absorption coefficients. However, prior to discussing method 400 additional information will be provided.

[0025] Diffusely propagated fluorescence is predicted by the coupled diffusion equations (1) and (2) given the optical properties of the tissue. The numerical solution of the diffusion equation may be needed to provide sufficiently accurate estimates of the fluence on the boundary of the tissue for the image reconstruction (or inverse) problem. The coupled diffusion equation used in optical tomography at a given modulation frequency $f(\omega=2\pi f \text{ rad})$ is given by:

$$\nabla \cdot [D_x(\vec{r}) \nabla \Phi_x(\vec{r}, \omega)] + \left[\frac{i\omega}{c} + \mu_{a,xi}(\vec{r}) + \mu_{a,xf}(\vec{r}) \right] \Phi_x(\vec{r}, \omega) = S \quad \text{on } \Omega \quad (1)$$

$$\nabla \cdot [D_m(\vec{r}) \nabla \Phi_m(\vec{r}, \omega)] + \left[\frac{i\omega}{c} + \mu_{a,m}(\vec{r}) \right] \Phi_m(\vec{r}, \omega) = \phi \mu_{a,xf} \frac{1}{1 - i\omega\tau} \Phi_x(\vec{r}, \omega) \quad \text{on } \Omega \quad (2)$$

[0026] Here, Φ_x and Φ_m are the AC components of the excitation and emission photon fluence (photons/cm²/sec) at

position \vec{r} , respectively; ω is the angular modulation frequency (rad/s); c is the speed of light within the medium (cm/s); $\mu_{a,xi}$ is the absorption due to chromophores (cm⁻¹); and $\mu_{a,xf}$ is the absorption due to fluorophores (cm⁻¹). $D_{x,m}$ is the optical diffusion coefficient equivalent to $\frac{1}{3}(\mu_{a,x,m} + \mu'_{s,x,m})$, where $\mu'_{s,x,m}$ is the isotropic scattering coefficient (cm⁻¹) and $\mu_{a,x,m}$ is the total absorption coefficient, at the respective wavelengths. The total absorption at the emission wavelength, $\mu_{a,m}$, is equal to the absorption owing to nonfluorescent chromophores, $\mu_{a,xi}$, and fluorescent chromophores, $\mu_{a,xf}$. The right hand term of equation (2) describes the generation of fluorescence within the medium. The term ϕ represents the quantum efficiency of the fluorescence process, which is defined as the probability that an excited fluorophore will decay radiatively, and τ is the fluorophore lifetime (ns). Note that the source term couples with the solution of excitation fluence described by equation (1). The numerical solutions for the excitation and emission fluence distributions given in equations (1) and (2), respectively, may be obtained using the Robin boundary condition. Other suitable mathematical models of light propagation and emission generation may be used to obtain the excitation and/or emission fluence distributions.

[0027] The source term S in equation (1) depends on the measurement types. For point illumination, the excitation source is represented as

$$S = \sum_{i=1}^{n_1} S \delta(\vec{r} - \vec{r}_s) \quad (3)$$

[0028] where \vec{r}_s is the positional vector of the illuminating point on the surface of the phantom; δ is the Dirac delta function representing the source of excitation at a single point; n_1 is the total number of simultaneous points of illumination, which is typically one. For area illumination, the area of the planar source can be discretized into a number of triangular finite elements and the source within a surface element in area coordinate is represented by

$$S = \sum_i^3 L_i^1 S_i \quad (4)$$

[0029] where the L_i^1 are the natural co-ordinates for the triangle and S_i is the source value at each node (i). The source term corresponding to the area illumination can be approximated as the summation of simultaneous and closely position multiple point sources as given by equation (4).

[0030] The Galerkin finite element method with tetrahedral in three-dimensions may be used to solve the differential equations (1) and (2). Local stiffness matrices may be formed for each element and then these matrices may be combined into two global stiffness matrices, K_x for the excitation equation and K_m for the emission equation. The solutions of the differential equations are obtained by solving the complex equations:

$$K_{x,m} \Phi_{x,m} = b_{x,m} \quad (5)$$

[0031] where $b_{x,m}$ is the right hand side of excitation and emission equations. The discretization process converts the

continuous problem into a problem with finite number of unknowns by expressing the unknown field variables, which are the absorption coefficients owing to fluorophore μ_{axf} in terms linear interpolation functions within each element. The linear functions are defined in terms of the values of the field variables at each node of the element. Therefore, the nodal values of the field variables become the unknowns to the image problem.

[0032] From the solution of $\Phi_{\text{x,m}}$, the values of the amplitude, $I_{\text{AC,x,m}}$, and phase shift, $\theta_{\text{x,m}}$, can be determined from the relationship:

$$\Phi_{\text{x,m}} = I_{\text{AC,x,m}} \exp(-i\theta_{\text{x,m}}) \quad (6)$$

[0033] Two finite elements meshes may be employed when solving the modified barrier penalty function. The first may contain 33431 nodes with 163285 tetrahedral elements (denoted below as Mesh 1) while the second, more refined mesh may contain 38919 nodes with 193137 tetrahedral elements (defined as Mesh 2). 1205 seconds and 1738 seconds of CPU time may be required to solve the coupled excitation and emission equations for Mesh 1 and Mesh 2, respectively. All the computations in this paper may be performed on a SUN-blade 100 UNIX workstation.

[0034] Information regarding the error function will also be provide prior to discussing method 400. The error function considered for the image reconstruction problems is as followed (for brevity we will use μ_a for μ_{axf} henceforth):

$$E(\mu_a, \omega) = \frac{1}{2} \sum_{p=1}^{N_D} [(\log(Z_p)_c - \log(Z_p)_m) (\log(Z_p)_c^* - \log(Z_p)_m^*)] \quad (7)$$

[0035] where E is the error function associated with measurements, Z_p is comprised of referenced fluorescent amplitude,

$$I_{\text{AC,ref}_p},$$

[0036] and referenced phase shift θ_{ref_p} measured at boundary point, p, in response to planewave illumination. Specifically the referenced measurement at boundary point p is given by:

$$Z_p = I_{\text{AC,ref}_p} \exp(i\theta_{\text{ref}_p}) \quad (8)$$

[0037] The experimental values of fluorescence modulated amplitude I_{AC_p} , may be divided by the maximum fluorescence experimental value from the collected reflectance data set, $I_{\text{AC}_{\text{max}}}$ in order to compute the referenced amplitude values,

$$I_{\text{AC,ref}_p}$$

[0038] The experimental fluorescence phase shift, at the position where the maximum fluorescence $I_{\text{AC}_{\text{max}}}$ was obtained, may be determined as

$$\theta_{\text{at } I_{\text{AC}_{\text{max}}}}$$

[0039] and subtracted from all experimental fluorescence phase shift values, θ_p in the collected reflectance data sets to obtained referenced phase shift values, θ_{ref_p} . These represent the "referenced" measurements:

$$I_{\text{AC,ref}_p} = \frac{I_{\text{AC}_p}}{I_{\text{AC}_{\text{max}}}}; \theta_{\text{ref}_p} = \theta_p - \theta_{\text{at } I_{\text{AC}_{\text{max}}}} \quad (9)$$

[0040] The predicted fluorescence

$$I_{\text{AC,ref}_p} \text{ and } \theta_{\text{ref}_p}$$

[0041] and θ_{ref_p} may be computed by solving the coupled diffusion equations (1 and 2) using the finite element method and may be similarly normalized to obtain the calculated values. Other suitable methods may be used to calculate these values. The referenced data are normalized in this manner in order to reduce, minimize, or eliminate instrument functions.

[0042] The error in equation (7) is reported for values of tissue absorption owing to fluorescent contrast agent. The subscript c denotes the values calculated by the forward solution and the subscript m denotes the experimental value. N_D denotes the number of detectors on the surface. The superscript * denotes the complex conjugate of the complex function of the referenced measurements.

[0043] The discussion regarding the coupled diffusion equations (1) and (2) and the error function (7) provides a basis for the modified barrier penalty function, M (termed hereafter as the barrier function), which is stated as followed:

$$\min_{\mu_a} M(\mu_a, \lambda, \eta) = E(\mu_a) - \eta \sum_{i=1}^n \lambda_i^l f(\mu_{a_i} - l) + \lambda_i^u f(u - \mu_{a_i}) \quad (11)$$

[0044] where η is a penalty/barrier term. n is the number of nodal points. λ^l and λ^u are vectors of Lagrange multipliers for the bound constraints for the lower and the upper bounds, respectively. From equation (11) one can see that the simple bounds are included in the barrier function M.

[0045] Function, f may be defined as:

$$f(h_i(\mu_a)) = \begin{cases} \log\left(s_i + \frac{h_i(\mu_a)}{\eta}\right) & \text{for } i = 1, 2, \dots, n \text{ if } h_i(\mu_a) \geq -\beta s_i \eta \\ \varphi(h_i(\mu_a)) & \text{for } i = 1, 2, \dots, n \text{ if } h_i(\mu_a) < -\beta s_i \eta \end{cases} \quad (12)$$

where

$$\varphi(h_i(\mu_a)) = \frac{1}{2} q_i^2 (h_i(\mu_a))^2 + q_i^1 h_i(\mu_a) + q_i^3 \quad (13)$$

[0046] $h_i(\mu_a)$ represents all the bound constraints $\{(\mu_{a_i} - 1) \text{ and } (u - \mu_{a_i})\}$; and s_i is positive-valued shifts used in the enlargement of the feasibility region for the lower and the upper bounds, respectively. In one embodiment, the s_i is set to 1.0 for all computations. The coefficients q_i^1 , q_i^2 , and q_i^3 of the quadratic function in equation (13) are chosen so that their values, and their first and second derivatives match those of the logarithmic term in equation (12) at the point $h_i(\mu_a) = -\beta s_i \eta$. The coefficients of the quadratic as given as:

$$q_i^1 = \frac{-1}{(s_i \eta (1 - \beta))^2} \quad (14)$$

$$q_i^2 = \frac{1 - 2\beta}{s_i \eta (1 - \beta)^2} \quad (15)$$

$$q_i^3 = \frac{\beta(2 - 3\beta)}{(2(1 - \beta)^2)} + \ln(s_i(1 - \beta)) \quad (16)$$

[0047] The coefficients are dependent on both β and η , and thus have to be updated for any changes of β and η . The values of β defines how close to the singularities the logarithmic terms described in equation (12) are extrapolated. Consequently we define a very simple differentiable modified barrier penalty function by equation (11) that is used to assess the quality of the solution. This function has an extremely simple structure so that the overhead for using the barrier function instead of the original error function given by equation (7) is negligible for function evaluation or for computing gradients and Hessian as discussed below.

[0048] The PMBF method **400** is performed in two stages in, an inner and an outer stage illustrated in **FIG. 4**. The outer iteration updates the Lagrange multiplier λ , parameter β , and the barrier parameter η . Formulations used to update these parameters at each outer iteration are provided in the discussion below. Using the calculated values of the parameter λ , an unconstrained technique may be applied to minimize the penalty barrier function described by equation (11). Once satisfactory convergence within the inner iteration is reached, the variables in the outer iteration are recalculated to check for satisfactory convergence in the outer iteration. If unsatisfactory, the Lagrange multipliers, the barrier parameters are updated and another unconstrained optimization is started within the inner iteration.

[0049] Turning to method **400**, method **400** begins at step **402** where initial values of μ_a , η and β are selected. The initial value for μ_a , the absorption coefficient due to fluorophore, is a positive value typically selected from the range of 0 to 0.1 cm^{-1} . The initial value for η , the barrier

parameter, is an arbitrary positive value and typically 10^{-1} or 10^{-2} . The initial value for β is a parameter that defines how close to the singularities the logarithmic terms in the modified barrier penalty function are extrapolated. The values of β are typically not too small (e.g., $0 \leq \beta \leq 0.5$) or very close to one (i.e., $\beta = 0.99$). For example, the value of β may be set to 0.9. Next, at decisional step **404**, if the initial values of λ^l , an initial Lagrange multiplier for a lower bound, and λ^u , an initial Lagrange multiplier for an upper bound, are selected, then, at step **406**, the values are set to equal values such as, for example, 1, 10, 100 and 1000. If the initial values of λ^l and λ^u are not initially selected, then, at step **408**, the values of λ^l and λ^u are determined. In one embodiment, the initial values of λ^l and λ^u are determined using a vector λ^0 that minimizes the least-squares unconstrained problem:

$$\min_{\lambda \geq 0} \|\nabla_{\mu_a} E(\mu_a^0) - \lambda \nabla_{\mu_a} f(h(\mu_a^0))\|_2^2 \quad (17)$$

[0050] this gives the formula:

$$\lambda(\mu_a^0) = A(\mu_a^0) \nabla_{\mu_a} E(\mu_a^0) \nabla_{\mu_a} f(h(\mu_a^0)) \quad (18)$$

[0051] where

$$A(\mu_a^0) = (\nabla_{\mu_a} f^T(h(\mu_a^0)) \nabla_{\mu_a} f(h(\mu_a^0)))^{-1} \quad (19)$$

[0052] The formulation of equation (18) requires calculation of all constraint gradients and the gradients of the error function $E(\mu_a^0)$ and inversion of the matrix $A(\mu_a^0)$. The inversion of this large ($n \times n$) matrix in the reconstruction problem can be very costly. To reduce the computational cost, only the diagonal terms of the equation (18) may be used. Hence there is no need to invert the matrix. Using this least-square procedure the initial Lagrange multipliers for image reconstruction problem may be computed. After the initial values of μ_a , η , β , λ^l , and λ^u are set, the indices k , which identifies the current step of the outer stage, is set to zero at step **410**.

[0053] Method **400** now executes the inner stage of the PMBF method by setting the indices j , which represents the current iteration of the inner stage, to zero at step **412**. Next, at step **414**, the barrier function, the gradient of the barrier function and the Hessian of the barrier function are calculated. The barrier function may be calculated by equation (11). During this calculation, an unconstrained optimization method may be used to optimize the unconstrained barrier function of equation (11) for each set of parameters λ^k and η^k . The truncated Newton method with trust region (TN) may be used for the unconstrained optimization problem. The gradient based truncated Newton method is efficient and suitable for large-scale problem. The gradient of the barrier function may given by

$$\nabla_{\mu_a} M(\mu_a, \lambda^k, \eta^k) = \quad (20)$$

-continued

$$\left\{ \begin{array}{l} \nabla_{\mu_a} E(\mu_a) - \eta^k \sum_{i=1}^n \frac{\lambda^k}{\left(\frac{h_i(\mu_a)}{\eta^k} + s_i \right)} \nabla h_{ix}(\mu_a) \text{ if } h_i(\mu_a) \geq -\beta^k s_i \eta^k \\ \nabla_{\mu_a} E(\mu_a) - \eta^k \sum_{i=1}^n \lambda^k \{q_i^1(h_i(\mu_a)) + q_i^2\} \text{ if } h_i(\mu_a) < -\beta^k s_i \eta^k \end{array} \right.$$

[0054] The gradients of the error function $\nabla_{\mu_a} E$ may be calculated by the analytical method using reverse differentiation technique. The Hessian of the barrier function may be determined as followed:

$$\nabla_{\mu_a}^2 M(\mu_a, \lambda^k, \eta^k) = \left\{ \begin{array}{l} \nabla_{\mu_a}^2 E(\mu_a) - \eta^k \sum_{i=1}^n \frac{\lambda^k}{(h_i(\mu_a) + s_i \eta^k)^2} h_i(\mu_a) \geq -\beta^k s_i \eta^k \\ \nabla_{\mu_a}^2 E(\mu_a) - \eta^k \sum_{i=1}^n \lambda^k \{q_i^1\} h_i(\mu_a) < -\beta^k s_i \eta^k \end{array} \right. \quad (21)$$

[0055] $\nabla_{\mu_a}^2 E(\mu_a) \cdot d$ maybe calculated by the finite difference scheme,

$$H(\mu_a) \cdot d = \frac{1}{\delta} \{ [g(\mu_a + \delta d)] - g(\mu_a) \} \quad (22)$$

[0056] where $\nabla_{\mu_a} E(\mu_a) = g(\mu_a)$ is the gradient; $\nabla_{\mu_a}^2 E(\mu_a) = H(\mu_a)$ is the Hessian of the error function $E(\mu_a)$; d is the Newton direction; and δ is (approximately) the square root of the machine precision. It may not safe to perform finite differencing directly to $\nabla_{\mu_a}^2 M$ because of the singularity of the logarithmic function. The final summation in the formulation for $\nabla_{\mu_a}^2 M$ may be computed straightforwardly from the formulas above.

[0057] If the absolute value of the gradient of the barrier function is less than 10^{-5} at decisional step 416, then the inner stage ends and execution proceeds to step 430 of the outer stage. Otherwise, $\nabla_{\mu_a}^2 M(\mu_a^j) d^j = \nabla_{\mu_a} M(\mu_a^j)$ is solved at step 418 to determine the Newton direction d . The Newton direction d is computed as an approximation solution of the Newton equations:

$$(\nabla^2 M) d = -\nabla M \quad (23)$$

[0058] where $\nabla^2 M = \nabla^2 M(\mu_a)$ is the Hessian matrix of second derivatives at the current solution designated by a vector μ_a . The approximate solution of equation (23) may be obtained by the linear conjugate-gradient method but the solution may alternatively be determined by any suitable method. This iterative method is "truncated" before the exact solution is obtained. The conjugate-gradient method (CG) corresponds to minimizing the quadratic model

$$\min_d Q(d) = \frac{1}{2} d^T \nabla^2 M d + d^T \nabla M \quad (24)$$

-continued

$$s.t. \quad l - \mu_a \leq d \leq u - \mu_a \quad (25)$$

[0059] as a function of d over a sequence of subspaces of increasing dimension. Criteria must be determined and applied to find out whether convergence has been achieved. This method has two levels of iterations, with the 'outer-level' iteration determining the step length, and the 'inner-level' iteration computing the Newton direction using conjugate gradient method. A further issue for unconstrained minimization is what to do when the current Hessian $\nabla^2 M$ is not positive definite. Several approaches are used, among the most popular of which are so-called modified Newton method in which d_j satisfies the linear system,

$$(\nabla^2 M(\mu_a^j) + R) d^j = -\nabla M \quad (26)$$

[0060] where R is a positive semidefinite matrix. Different techniques have used to calculate R so that $(\nabla^2 M(\mu_a^j) + R)$ is positive definite. An alternative globalization strategy in unconstrained optimization embodied in trust region methods, is to choose the step d^j to minimize the local Taylor-series model subject to a limitation on the size of $\|d^j\|$, where various norms may appear in the trust-region constraints. To alleviate this difficulty, the conjugate gradient method with trust region may be used for unconstrained optimization problems. The procedure is described in the following paragraph as followed:

[0061] CG methods generate sequences p^i, y^i , where p^i approximates iteratively the Newton direction d^i and the conjugate direction y^i . The update scheme is

$$p^{i+1} = p^i + \Lambda^i y^i \quad (27)$$

$$y^{i+1} = p^{i+1} + \rho^i y^i \quad (28)$$

[0062] where Λ^i minimizes the quadratic function $Q(d)$ along the direction y^i , and ρ^i is chosen so as to maintain conjugacy between the directions y^i . The CG terminates when the residual $r^i = -\nabla Q(p^i)$ is in norm below a prescribed tolerance or when a negative curvature direction $\tau_1 = (s^i)^T \nabla^2 M s^i \leq 0$ is encountered. This algorithm does not stop, but computes $\tau_1 > 0$ so that $\|p^i + \tau_1 y^i\| = \Delta$, where Δ is the trust region. Then update rule is $d^{i+1} = d^i + \tau_1 y^i$. The algorithm stops if the residual $\|r^i\|$ is below a given tolerance, or if $(y^i)^T \nabla^2 M y^i = 0$.

[0063] Next, at step 420, a new estimate of the absorption owing to fluorophore is determined by $\mu_a^{j+1} = \mu_a^j + \alpha d^j$, where α is the step length. The step length may be determined by an Armijo line search algorithm as disclosed in M. S. Bazaraa, H. D. Sherali, and C. M. Shetty, *Nonlinear programming theory and algorithms*, John Wiley & Sons Inc, New York., 1993. The Newton direction d may be required to satisfy $d^T \nabla M < 0$ (i.e., it is a descent direction for M at the point μ_a). The step length $\alpha > 0$ may be chosen to guarantee that $M(\mu_a) < M(\mu_a)$, along with Wolfe's conditions disclosed in P. Wolfe, "Convergence condition for ascent method," *SIAM Rev.*, 11, 226-253, 1969, which are designed to guarantee convergence to a local minimum.

[0064] At decisional step 422, it is determined whether μ_a^{j+1} is an active variable. In general, if the variables of an unconstrained problem are very close to a bound in the inner iteration, then these variables are fixed (call active variables). Hence the start of the next unconstrained optimiza-

tion uses the free variables only. The variables in $B(\mu_a)$ and $B'(\mu_a)$ are called active variables and the variables in $C(\mu_a)$ are called free variables

$$B(\mu_a) = \{i: l \leq \mu_{a_i} \leq l + \epsilon\} \quad (25)$$

$$B'(\mu_a) = \{i: u - \epsilon \leq \mu_{a_i} \leq u\} \quad (26)$$

$$C(\mu_a) = \{i: l + \epsilon \leq \mu_{a_i} \leq u - \epsilon\} \quad (27)$$

[0065] where i is the number of nodal points $i=1, \dots, n$, l is the lower bound of the absorption coefficient owing to fluorophore, u is the upper bound of the absorption coefficient owing to fluorophore, and the tolerance E should be sufficiently small, such that

$$l + \epsilon < u - \epsilon \quad (28)$$

[0066] For example, the tolerance ϵ may be set to 10^{-3} , 10^{-4} , 10^{-6} , or other suitable values. All variables in the active set are fixed during the iteration, while the other variables in set C are free. After each iteration, the active variables may be updated from current free variables, i.e., variables may be found that lie within the bounds and add to previous active variables. The active sets B and B' are updated at the inner iteration and the process is continued until the gradient of the barrier function M described by (11) can not be reduced further with the current free variables.

[0067] The variables μ_{a_i} in $C = \{\mu_{a_i} | l \leq \mu_{a_i} \leq u\}$ have three mutually exclusive possibilities:

$$(i) \quad 0 \leq \mu_{a_i} - l \leq \nabla_{\mu_{a_i}} M(\mu_a, \lambda, \eta) \quad (29)$$

$$(ii) \quad \nabla_{\mu_{a_i}} M(\mu_a, \lambda, \eta) \leq \mu_{a_i} - u \leq 0 \quad (30)$$

$$(iii) \quad \mu_{a_i} - u \leq \nabla_{\mu_{a_i}} M(\mu_a, \lambda, \eta) \leq \mu_{a_i} - l \quad (31)$$

[0068] The vector of μ_{a_i} that satisfies (i) or (ii) are now the dominated variables. The ones satisfying (i) are said to be dominated above; and those satisfying (ii) dominated below; and those satisfying (iii) are the floating variables.

[0069] If a convergence condition is satisfied at decisional step 424, then inner stage ends and method 400 proceeds to step 430 of the outer stage. In the illustrated embodiment, the inner iteration can be considered fully converged if either of the following two conditions are satisfied. The first convergence condition is

$$\left\| \frac{\nabla_{\mu_a} M(\mu_a^j, \lambda^j, \eta^j)}{1.0 + \|\mu_a^j\|} \right\| < \tau_1^k \quad (32)$$

[0070] where k is the number of the subproblem and j is the number of inner iteration. If τ_1^k is less than 10^{-5} then the inner iteration is stopped and the outer iteration are continued. The second convergence condition is satisfied if the fractional change d_2 given by (33) of the barrier function M of equation (11) of consecutive inner iterations is less than $\epsilon_0 = 10^{-5}$ then the inner iteration is stopped and the outer iteration are continued.

$$d_2 = \frac{|M(\mu_a^{j+1}, \lambda^k, \eta^k) - M(\mu_a^j, \lambda^k, \eta^k)|}{1.0 + |M(\mu_a^j, \lambda^k, \eta^k)|} \quad (33)$$

[0071] If neither convergence condition is satisfied at decisional step 424, then, at step 426, the inner iteration indices j is set to $j+1$. If the inner iteration indices j does not satisfies the specified number of inner iterations (e.g., 5, 10, etc) at decisional step 428, the inner iteration returns to step 418. Otherwise, the inner iteration ends, and execution returns to the outer iteration at step 430.

[0072] At step 430, the outer iteration indices k is set to $k+1$. If the outer iteration indices k satisfies the specified number of outer iterations (e.g., 6) at decisional step 432, then, at step 434, the absorption coefficient due to fluorophores μ_a is set to the current estimated value μ_a^{j+1} and execution ends. If the outer iteration indices k does not satisfy the specified number of outer iterations at decisional step 432, then execution proceeds to decision step 436. If a convergence criteria is satisfied at decisional step 436, then execution ends. The outer iteration of the PMBF can be considered fully converged if it satisfies any of the following conditions:

$$\gamma_1^{k+1} = \frac{\left\| \nabla_{\mu_a} E(\mu_a^{k+1}) - \eta^k \sum_{i=1}^n \lambda_i^k \nabla_{\mu_a} h_i(\mu_a^{k+1}) \right\|}{1.0 + \|\mu_a^{k+1}\|} < \varsigma \quad (34)$$

$$\gamma_2^{k+1} = \frac{\left| \eta^k \sum_{i=1}^n \lambda_i^k \nabla_{\mu_a} h_i(\mu_a^{k+1}) \right|}{1.0 + \|\mu_a^{k+1}\|} < \varsigma \quad (35)$$

[0073] where k is the number of subproblem. If ς is less than 10^{-5} , then the inner iteration is stopped. If the fractional change d_1 given by equation (36) of the barrier function M given by equation (11) for the consecutive outer iterations is less than $\epsilon_0 = 10^{-5}$, then the outer iteration is stopped.

$$d_1 = \frac{|M(\mu_a^{k+1}, \lambda^{k+1}, \eta^{k+1}) - M(\mu_a^k, \lambda^k, \eta^k)|}{1.0 + |M(\mu_a^k, \lambda^k, \eta^k)|} \quad (36)$$

[0074] If the outer iteration convergence criteria are not satisfied at decisional step 436, then, at step 438, λ^k , λ^{k+1} , and β are updated. The Lagrangian multipliers may be updated as followed:

$$\lambda^{k+1} = \begin{cases} \eta^k \lambda_i^k \left(\frac{1}{\eta^k s_i + h_i(\mu_a)} \right) & \text{for } i = 1, 2, \dots, n \quad h_i(\mu_a) \geq -\beta^k s_i \eta^k \\ \eta^k \lambda_i^k (q_i^1 h_i(\mu_a) + q_i^2) & \text{for } i = 1, 2, \dots, n \quad h_i(\mu_a) < -\beta^k s_i \eta^k \end{cases} \quad (37)$$

[0075] where λ_i represents all the Lagrange multipliers for the bound constraints (λ^l and λ^u) and $h_i(\mu_a)$ represents all the

bound constraints. η may be updated by a simple reduction rule:

$$\eta^{k+1} = \eta^k / \gamma \quad (38)$$

[0076] where $\gamma > 1$ is defined by the user, and normally $\gamma = 2$ or $\gamma = 10$, and k is the number of the outer iteration.

[0077] Next, at step 440, μ_{a_i} is updated at nodal point i , after k^{th} outer iteration as follows:

$$(\mu_a^k)_i = \begin{cases} l & \text{if } 0 \leq (\mu_a^{k-1})_i - l \leq (\nabla \mu_a M^{k-1})_i \\ u & \text{if } (\nabla \mu_a M^{k-1})_i \leq (\mu_a^{k-1})_i - l \leq 0 \\ (\mu_a^{k-1})_i & \text{otherwise} \end{cases} \quad (39)$$

[0078] Execution returns to step 412 to return to the inner stage.

[0079] FIGS. 5A-C illustrate x-z views of a 3D distribution of a fluorescent target which provides example data generated according to the teachings of the invention. These reconstructions used the following initial values $\mu_{a_{\text{st}}}^0 = 0.03 \text{ cm}^{-1}$ and $\lambda^0 = 1000$, $\mu_{a_{\text{st}}}^0 = 0.003 \text{ cm}^{-1}$ and $\lambda^0 = 1000$, and $\mu_{a_{\text{st}}}^0 = 0.003 \text{ cm}^{-1}$ and $\lambda^0 = 1000$, respectively. A tissue phantom consisting of an $8 \times 8 \times 8 \text{ cm}^3$ cube filled with 1% lipid solution to mimic the scattering properties of tissue was used in the system of FIGS. 1 and 2. The target to be reconstructed in these initial studies was a 1 cm^3 cube filled with 1% lipid and 1 μM Indocyanine Green solution placed 1 cm from the imaging surface. The top surface of the tissue phantom was illuminated with an expanded beam of 785-nm excitation light which was intensity modulated at 100 MHz. The surface area illuminated was approximately 9 cm^2 . The emitted fluorescent signal in this area was imaged using a gain modulated intensified charge coupled device (ICCD) operated under homodyne conditions to enable determination of the amplitude and phase-delay of the light emitted on the top of the surface. Using a combination crossed and parallel polarizers on the incident and collected light, the spatial distribution of the amplitude and phase delay of the incident excitation light was determined. Next upon placing an 830 nm interference and imaging holographic filters at the photocathode of the intensifier, the amplitude and phase delay of the re-emitted fluorescent light owing to the submerged target was determined across the surface of the phantom.

[0080] One advantage of this procedure is that optical fibers are not required to illuminate or collect the light signal unlike the traditional point illumination/collection measurement schemes used in optical tomography. An additional advantage of this procedure is the ability to reconstruct 3D images from data collected at a 2D sensor surface.

[0081] Although the present invention has been described in detail, various changes and modifications may be suggested to one skilled in the art. It is intended that the present invention encompass such changes and modifications as falling within the scope of the appended claims.

What is claimed is:

1. A method of imaging, comprising:

directing time-varying excitation light at a surface area of a tissue, the tissue comprising a fluorescent target;

modulating the intensity of the excitation light at a radio frequency;

detecting, substantially at a two-dimensional sensor surface, time-varying emission light from the fluorescent target in response to the time-varying excitation light stimulating the fluorescent target;

filtering the time-varying emission light to reject excitation light re-emitted from the material;

determining a spatial distribution of amplitude and phase-delay of the detected time-varying emission light;

detecting time-varying excitation light specularly reflected by the fluorescent target;

determining a spatial distribution of amplitude and phase-delay of the time-varying excitation light incident on the surface area based on the reflected time-varying excitation light; and

generating a three-dimensional image of the fluorescent target based on the spatial distributions of the incident time-varying excitation light and the time-varying emission light.

2. A method of imaging, comprising:

directing time-varying excitation light at a surface area of a light scattering material, the material comprising a fluorescent target;

detecting, substantially at a two-dimensional sensor surface, time-varying emission light from the fluorescent target in response to the time-varying excitation light stimulating the fluorescent target;

filtering the time-varying emission light to reject excitation light re-emitted from the material; and

generating a three-dimensional image of the fluorescent target based on the detection substantially at the sensor surface.

3. The method of claim 2, wherein the fluorescent agent comprises indocyanine green ("ICG").

4. The method of claim 2, wherein the surface area is greater than 1 millimeter squared (mm^2).

5. The method of claim 2, further comprising determining a spatial distribution of amplitude and phase-delay of the detected time-varying emission light.

6. The method of claim 5, further comprising:

detecting time-varying excitation light specularly reflected by the fluorescent target; and

determining a spatial distribution of amplitude and phase-delay of the time-varying excitation light incident on the surface area based on the reflected time-varying excitation light.

7. The method of claim 6, wherein in the three dimensional image of the fluorescent target is based on the spatial distributions of the incident time-varying excitation light and the time-varying emission light.

8. The method of claim 2, wherein the time-varying excitation light comprises a planar wave.

9. The method of claim 2, wherein the material comprises tissue.

10. The method of claim 2, further comprising modulating the intensity of the excitation light at a radio frequency.

11. The method of claim 6, wherein detecting time-varying excitation light singularly reflected by the fluorescent target comprises:

detecting excitation light emitted from the light scattering material;

detecting multiply scattered excitation light emitted from the light scattering material; and

subtracting the detected multiply scattered excitation light from the detected excitation light emitted from the light scattering material to determine the specularly reflected excitation light.

12. The method of claim 2, wherein the two-dimensional sensor surface is approximately 16 cm².

13. A system for imaging, comprising:

a laser diode operable to direct time-varying excitation light at a surface area of a light scattering material, the material comprising a fluorescent target;

an image intensifier operable to detecting, substantially at a two-dimensional sensor surface, time-varying emission light from the fluorescent target in response to the time-varying excitation light stimulating the fluorescent target;

one or more optical filters operable to filter the time-varying emission light to reject excitation light re-emitted from the material; and

an imaging apparatus operable to generate a three-dimensional image of the fluorescent target based on the detection substantially at the sensor surface.

14. The system of claim 13, wherein the fluorescent agent comprises indocyanine green ("ICG").

15. The system of claim 13, wherein the surface area is approximately 9 centimeters squared (cm²).

16. The system of claim 13, the imaging apparatus further operable to determine a spatial distribution of amplitude and phase-delay of the detected time-varying emission light.

17. The system of claim 13, further comprising a plurality of linear polarizers operable to pass reflected excitation light in a first configuration and multiply-reflected excitation light in a second configuration; and the image apparatus further operable to determine a spatial distribution of amplitude and phase-delay of the time-varying excitation light incident on the surface area based on the reflected and multiply reflected excitation light.

18. The system of claim 17, wherein in the three dimensional image of the fluorescent target is based on the spatial distributions of the incident time-varying excitation light and the time-varying emission light.

19. The system of claim 13, wherein the time-varying excitation light comprises a planar wave.

20. The system of claim 13, wherein the material comprises tissue.

21. The system of claim 13, wherein an intensity of the time-varying excitation light is modulated at a radio frequency.

* * * * *

专利名称(译)	用于具有区域照明和区域检测的近红外荧光对比度增强成像的方法和系统		
公开(公告)号	US20050085732A1	公开(公告)日	2005-04-21
申请号	US10/872333	申请日	2004-06-18
[标]申请(专利权)人(译)	SEVICK MURACA EVA中号 THOMPSON ALAN乙 RANADHIR ROY		
申请(专利权)人(译)	SEVICK-MURACA EVA M. THOMPSON ALAN B. RANADHIR ROY		
[标]发明人	SEVICK MURACA EVA M THOMPSON ALAN B RANADHIR ROY		
发明人	SEVICK-MURACA, EVA M. THOMPSON, ALAN B. RANADHIR, ROY		
IPC分类号	A61B5/00 G01N21/64 A61B6/00		
CPC分类号	A61B5/0059 A61B5/0073 G01N21/6456 G01N21/6428 G01N21/6408		
优先权	60/480526 2003-06-20 US		
其他公开文献	US7599732		
外部链接	Espacenet USPTO		

摘要(译)

根据本发明的一个实施例，一种用于生物医学成像的方法包括将时变激发光引导到光散射材料的表面区域，该材料包括荧光靶。响应于刺激荧光目标的时变激发光，基本上在二维传感器表面检测来自荧光目标的随时间变化的发射光。过滤时变发射光以抑制从材料重新发射的激发光。基于在传感器表面处的检测，生成荧光目标的三维图像。

