



US009194749B2

(12) **United States Patent**
Pompei

(10) **Patent No.:** **US 9,194,749 B2**
(45) **Date of Patent:** ***Nov. 24, 2015**

(54) **TEMPORAL ARTERY TEMPERATURE DETECTOR**

USPC 128/736, 664; 374/130, 131, 132, 121
See application file for complete search history.

(75) Inventor: **Francesco Pompei**, Boston, MA (US)

(56) **References Cited**

(73) Assignee: **Exergen Corporation**, Watertown, MA (US)

U.S. PATENT DOCUMENTS

(*) Notice: Subject to any disclaimer, the term of this patent is extended or adjusted under 35 U.S.C. 154(b) by 142 days.

2,658,390 A 11/1953 Machler
2,710,559 A 6/1955 Heitmuller et al.

(Continued)

This patent is subject to a terminal disclaimer.

FOREIGN PATENT DOCUMENTS

(21) Appl. No.: **12/857,252**

CN 1182208 A 5/1998
DE 19 14 468 B2 11/1970

(Continued)

(22) Filed: **Aug. 16, 2010**

(65) **Prior Publication Data**

US 2011/0092822 A1 Apr. 21, 2011

Related U.S. Application Data

OTHER PUBLICATIONS

“Surface Temperature Scanner STS-100-F/C & 101-C,” Omega Medical Corporation, pamphlet, 2 pages, Circa 1987.

(Continued)

(63) Continuation of application No. 12/011,467, filed on Jan. 25, 2008, now Pat. No. 7,787,938, which is a continuation of application No. 10/684,818, filed on Oct. 14, 2003, now Pat. No. 7,346,386, which is a

(Continued)

Primary Examiner — Elmer Chao

(74) *Attorney, Agent, or Firm* — Hamilton, Brook, Smith & Reynolds P.C.

(51) **Int. Cl.**

A61B 6/00 (2006.01)
A61B 5/00 (2006.01)
G01K 1/00 (2006.01)

(Continued)

(57) **ABSTRACT**

Body temperature measurements are obtained by scanning a thermal radiation sensor across the side of the forehead over the temporal artery. A peak temperature measurement is processed to compute an internal temperature of the body as a function of ambient temperature and the sensed surface temperature. The function includes a weighted difference of surface temperature and ambient temperature, the weighting being varied with target temperature through a minimum in the range of 96° F. and 100° F. The radiation sensor views the target surface through an emissivity compensating cup which is spaced from the skin by a circular lip of low thermal conductivity.

(52) **U.S. Cl.**

CPC . **G01J 5/04** (2013.01); **A61B 5/015** (2013.01); **G01J 5/0022** (2013.01); **G01J 5/0025** (2013.01); **G01J 5/02** (2013.01); **G01J 5/026** (2013.01); **G01J 5/06** (2013.01); **G01J 5/16** (2013.01)

(58) **Field of Classification Search**

CPC A61B 5/015; G01J 5/0022; G01J 5/04; G01J 5/0025; G01J 5/02; G01J 5/026; G01J 5/06; G01J 5/16

13 Claims, 4 Drawing Sheets

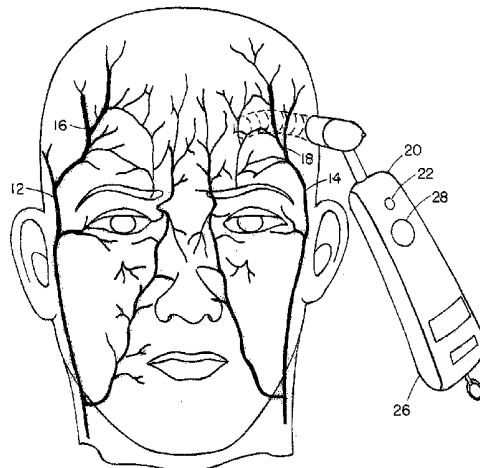

Related U.S. Application Data

continuation of application No. 09/923,240, filed on Aug. 3, 2001, now abandoned, which is a continuation of application No. 09/151,482, filed on Sep. 11, 1998, now Pat. No. 6,292,685.

(51) **Int. Cl.**

- G01K 13/12** (2006.01)
- G01J 5/04** (2006.01)
- A61B 5/01** (2006.01)
- G01J 5/00** (2006.01)
- G01J 5/02** (2006.01)
- G01J 5/06** (2006.01)
- G01J 5/16** (2006.01)

5,050,612 A	9/1991	Matsumura	
5,056,929 A	10/1991	Watanabe et al.	
5,115,815 A	5/1992	Hansen	
5,150,969 A	9/1992	Goldberg et al.	
5,159,936 A	11/1992	Yelderman et al.	
5,167,235 A	12/1992	Seacord et al.	
5,178,464 A	1/1993	Fraden	
5,187,943 A	2/1993	Taniguchi et al.	
5,199,436 A	4/1993	Pompei et al.	
5,229,612 A	7/1993	Pompei et al.	
5,232,284 A	8/1993	Egawa et al.	
5,271,407 A	12/1993	Pompei et al.	
RE34,507 E	1/1994	Egawa et al.	
5,293,877 A	3/1994	O'Hara	
5,325,863 A	7/1994	Pompei	
5,333,784 A	8/1994	Pompei	
5,368,038 A	11/1994	Fraden	
5,381,796 A	1/1995	Pompei	
5,386,831 A	2/1995	Gluck	
5,441,476 A *	8/1995	Kitado et al.	600/26
5,445,158 A	8/1995	Pompei	
5,469,855 A	11/1995	Pompei et al.	
5,553,503 A	9/1996	Surdut et al.	
5,626,139 A	5/1997	Szeles et al.	
5,626,147 A	5/1997	Lackey	
RE35,554 E	7/1997	Pompei et al.	
5,653,238 A	8/1997	Pompei	
5,662,104 A *	9/1997	Fuse et al.	600/325
5,695,283 A	12/1997	Johnson	
5,725,308 A	3/1998	Smith et al.	
5,740,809 A	4/1998	Baratta	
5,743,644 A	4/1998	Kobayashi et al.	
5,818,044 A	10/1998	Sodickson et al.	
5,872,362 A	2/1999	Pompei	
5,874,736 A	2/1999	Pompei	
5,893,833 A	4/1999	Pompei et al.	
5,924,996 A	7/1999	Cho et al.	
5,924,998 A	7/1999	Cornelius et al.	
6,001,066 A	12/1999	Canfield et al.	
6,030,342 A	2/2000	Amano et al.	
6,047,205 A	4/2000	Pompei	
6,056,435 A	5/2000	Pompei	
6,059,452 A	5/2000	Smith et al.	
6,287,262 B1	9/2001	Amano et al.	
6,292,685 B1	9/2001	Pompei	
6,299,347 B1	10/2001	Pompei	
6,499,877 B2	12/2002	Pompei	
7,346,386 B2	3/2008	Pompei	
7,787,938 B2	8/2010	Pompei	

(56)

References Cited

U.S. PATENT DOCUMENTS

3,273,395 A	9/1966	Schwarz
3,282,106 A	11/1966	Barnes
3,374,354 A	3/1968	Hood
3,392,282 A	7/1968	Astheimer
3,491,596 A	1/1970	Dean
3,526,135 A	9/1970	Wortz
3,531,642 A	9/1970	Barnes et al.
3,581,570 A	6/1971	Wortz
3,614,892 A	10/1971	Ottenstein
3,719,838 A	3/1973	Peduto et al.
3,777,568 A	12/1973	Risgin et al.
3,781,837 A	12/1973	Anderson et al.
3,933,045 A	1/1976	Fox et al.
4,005,605 A	2/1977	Michael
4,133,700 A	1/1979	Hollander et al.
4,138,889 A	2/1979	Fraschini
4,141,149 A	2/1979	George et al.
4,161,880 A	7/1979	Prosky
4,198,861 A	4/1980	Mung-Kuen Luk
4,204,120 A	5/1980	Riboulet et al.
4,301,682 A	11/1981	Everest
4,302,971 A	12/1981	Luk
4,317,998 A	3/1982	Dore
4,372,690 A	2/1983	Berman et al.
4,403,296 A	9/1983	Prosky
4,420,265 A	12/1983	Everest et al.
4,428,382 A	1/1984	Walsall et al.
4,456,390 A	6/1984	Junkert et al.
4,456,919 A	6/1984	Tomita
4,494,881 A	1/1985	Everest
4,566,808 A	1/1986	Pompei
4,602,642 A	7/1986	O'Hara et al.
4,623,266 A	11/1986	Kielb
4,626,686 A	12/1986	Pompei et al.
4,634,294 A	1/1987	Christol et al.
4,636,091 A	1/1987	Pompei et al.
4,691,713 A	9/1987	Suzuki
4,722,612 A	2/1988	Junkert et al.
4,726,688 A	2/1988	Ruel
4,784,149 A	11/1988	Berman et al.
4,790,324 A	12/1988	O'Hara et al.
4,797,840 A	1/1989	Fraden
4,831,258 A	5/1989	Paulk et al.
4,843,577 A	6/1989	Muramoto
4,846,583 A	7/1989	Yamamoto
4,854,730 A	8/1989	Fraden
4,866,621 A	9/1989	Ono
4,895,164 A	1/1990	Wood
4,907,895 A	3/1990	Everest
4,932,789 A	6/1990	Egawa et al.
4,993,419 A	2/1991	Pompei et al.
5,012,813 A	5/1991	Pompei et al.
5,017,018 A	5/1991	Iuchi et al.
5,017,019 A	5/1991	Pompei
5,018,872 A	5/1991	Suszynski et al.
5,024,533 A	6/1991	Egawa et al.

FOREIGN PATENT DOCUMENTS

DE	298 18 615	UI	2/1999
EP	1 226 540		3/1971
EP	55037917		3/1980
EP	0018424	A1	11/1980
EP	0180368		10/1985
EP	0337724	A2	10/1989
EP	0 411 121	A1	6/1991
EP	0 446 788	A1	9/1991
EP	0 845 241	A1	6/1998
EP	1114302	B1	2/2012
GB	1226540		3/1971
JP	55-011597		1/1980
JP	5511597		1/1980
JP	58-088627		5/1983
JP	61-117422		6/1986
JP	02-045719		2/1990
JP	2035322	A	2/1990
JP	02-252445		10/1990
JP	06-117882	A	4/1994
JP	06-341906		12/1994
JP	7140008	A	6/1995
JP	8254467	A	10/1995
JP	08-275924	A	10/1996
JP	09-113634		5/1997
JP	11-155826		6/1999
WO	WO 81/00764		3/1981
WO	WO 86/06163		10/1986

(56) **References Cited**

FOREIGN PATENT DOCUMENTS

WO	WO 93/03666	3/1993
WO	WO 97/47239	12/1997
WO	WO 98/01730	1/1998
WO	WO 98/08431	5/1998
WO	WO 98/59277 A1	12/1998
WO	WO 99/39166	8/1999

OTHER PUBLICATIONS

“Sensor Touch Temporal Artery Thermometer—The Noninvasive Thermometer You Can Trust,” 5 page brochure, Exergen Corporation, 1999.

Wei, D., et al., “Optimal Design of a Thermistor Probe for Surface Measurement of Cerebral Blood Flow,” *Transactions on Biomedical Engineering*, 37(12):1159-1172, 1990.

Database WPL, Section PQ, Week 9505, Derwent Publications Ltd., London, GB, May 15, 1994, Abstract.

Omega Medical Surface Temperature Scanner STS-100-F/C & 101-C, 2 pages.

DET Tronics, Optical Calibration, Oct. 1987.

Model 1M Thermopile Detector, Dexter Research Center, Technical Description, Oct. 1980.

Fraden, Jacob, “Application of Piezo/Pyroelectric Films in Medical Transducers,” *J. Clinical Engineering*, 13(3):133-138 (1988).

Houdas, Y. and Ring, E.F.J., “Human Body Temperature, Its Measurement and Regulation,” Plenum Press, N.Y., pp. 83, 1982.

Looney, Jr., Joseph M. and Pompei, Francisco, “Ear Thermometry,” *Medical Electronics*, Jun. 1989.

Surface Temperature Scanner, Models: STS100-F/C, STS-101-C, User Manual, 9 pages.

Proceedings of the Eighth Annual Conference of the IEEE/Engineering in Medicine and Biology Society, vol. 3 of 3, Nov. 7-10, 1986.

Ryan, Marybeth, “The Equine Infrared Thermographic Scanner: Assuring Performance of the Equine Athlete,” Exergen Corporation, 4 pages, 1989.

Pompei, Marybeth, “Temperature Assessment via the Temporal Artery: Validation of a New Method,” Exergen Corporation, 1999.

Sketch of Radiation Detector Manufactured by IR-ONICS Corporation and distributed by Dermatherm Corporation, pre 1983.

Kuzucu, Etham Y., “Measurement of Temperature,” *Int. Anesthesiol Clin.* 3(3):435-449 (1965).

PET™, Physician’s Electronic Thermometer, Phillips Bio-Medical, Inc., Specifications, 2 pgs.

FirstTemp Intelligent Medical Systems, Model 2000A, Operation Manual, 8 pages.

ComforTemp All-Family Instant Underarm Thermometer, Quick Start Instructions, 6 pages.

FirstTemp Clinical Thermometer, Technical Manual, 24 pages.

Notification of Reason(s) for Rejection mailed May 7, 2009 for JP Application No. 2000-570539.

Exergen Corporation v. Wal-Mart Stores, Inc., et al, United States Court of Appeal for the Federal Circuit, 2006-1491,2007-1180.

Notification of Reason(s) for Rejection mailed: Aug. 25, 2009 for JP Application No. 2000-570539 (with English Translation attached).
Communication Pursuant to Article 96(2) EPC mailed: Jan. 15, 2003 for European Application No. 99 945 647.8.

Communication Pursuant to Article 115(2) EPC mailed: Sep. 24, 2003 for European Application No. 99 945 647.8.

Communication Pursuant to Article 96(2) EPC mailed: Jan. 24, 2006 for European Application No. 99 945 647.8.

Communication Pursuant to Article 94(3) EPC mailed: Apr. 16, 2008 for European Application No. 99 945 647.8.

Communication Pursuant to Article 94(3) EPC mailed: Mar. 25, 2009 for European Application No. 99 945 647.8.

Pompei & Pompei, *Physicians Reference Handbook on Temperature: Vital Sign Assessment with Infrared Thermometry*, Exergen Corporation, Boston, MA (entire book enclosed).

Marybeth Pompei, Letter dated Jun. 13, 1997 to Jeffrey Blummer, MD.

Marybeth Pompei, Letter dated Jun. 15, 1997 to Jeffrey Blummer, MD.

Marybeth Pompei, Letter dated Jul. 20, 1997 to Jeffrey Blummer, MD.

Marybeth Pompei, Letter dated Aug. 10, 1997 to William Walsh, MD. Francesco Pompei, Non-Invasive Arterial Thermometry: *from Physics and Physiology to Physicians and Nurses*, Sep. 16, 1997.

“Tecnimed SRL’s Preliminary Invalidity Disclosures,” *Exergen Corporation v. Kidz-Med, Inc., et al*, United States District Court for District of Massachusetts, Case No. 1:08-CV-11416-DPW, May 6, 2009.

“Exergen’s Responses to Tecnimed’s Preliminary Invalidity Contentions,” *Exergen Corporation v. Kidz-Med, Inc., et al*, United States District Court for District of Massachusetts, Case No. 08-CV-11416-DPW, Jun. 8, 2009.

“Tecnimed’s Preliminary Identification of Claim Terms and Proposed Construction,” *Exergen Corporation v. Kidz-Med, Inc., et al*, United States District Court for District of Massachusetts, Case No. 1:08-CV-11416-DPW, Aug. 14, 2009.

“Plaintiff Exergen Corporation’s Supplemental Proposed Claim Constructions,” *Exergen Corporation v. Kidz-Med, Inc., et al*, United States District Court for District of Massachusetts, Case No. 08-CV-11416-DPW, Jan. 26, 2010.

“Tecnimed’s Updated Identification of Claim Terms and Proposed Constructions,” *Exergen Corporation v. Kidz-Med, Inc., et al*, United States District Court for District of Massachusetts, Case No. 1:08-CV-11416-DPW, Feb. 19, 2010.

“Deposition of Francesco Pompei,” (Redacted), including Exhibits 3, 4 and 6, *Exergen Corporation v. Kidz-Med, Inc., et al*, United States District Court for District of Massachusetts, Case No. 1:08-CV-11416-DPW, Aug. 27, 2009.

“Expert Witness Report of Jack Goldberg,” *Exergen Corporation v. Wal-Mart Stores, Inc., et al*, United States District Court for District of Massachusetts, Case No. 01-CV-11306-RCL, Jan. 17, 2003.

“Disclosure of Expert Rebuttal Testimony of Dr. Francesco Pompei,” *Exergen Corporation v. Wal-Mart Stores, Inc., et al*, United States District Court for District of Massachusetts, Case No. 01-CV-11306-RCL, Mar. 3, 2009.

“Supplemental Expert Witness Report of Jack Goldberg,” *Exergen Corporation v. Wal-Mart Stores, Inc., et al*, United States District Court for District of Massachusetts, Case No. 01-CV-11306-RCL, Jan. 21, 2005.

“Second Supplemental Expert Witness Report of Jack Goldberg,” *Exergen Corporation v. Wal-Mart Stores, Inc., et al*, United States District Court for District of Massachusetts, Case No. 01-CV-11306-RCL, Jan. 21, 2005.

Transcript of Jury Trial Day 5, *Exergen Corporation v. S.A.A.T. Systems Application of Advanced Technology Ltd., et al*, United States District Court for District of Massachusetts, Case No. 01-CV-11306-RCL, Jun. 17, 2005.

Transcript of Jury Trial Day 13, *Exergen Corporation v. S.A.A.T. Systems Application of Advanced Technology Ltd., et al*, United States District Court for District of Massachusetts, Case No. 01-CV-11306-RCL, Jul. 5, 2005.

Transcript of Jury Trial Day 14, *Exergen Corporation v. S.A.A.T. Systems Application of Advanced Technology Ltd., et al*, United States District Court for District of Massachusetts, Case No. 01-CV-11306-RCL, Jul. 6, 2005.

Benzinger, T.H., “Heat Regulation: Homeostasis of Central Temperature in Man,” *Physiological Reviews*, 49(4): 671-759 (Oct. 1969).

Castle, S.C., et al., “The Equivalency of Infrared Tympanic Membrane Thermometry with Standard Thermometry in Nursing Home Residents,” Abstract, Erratum and Comment in *J. Am. Geriatr. Soc.* 41(7): 781-782 (Jul. 1993).

Houdas, Y. and E.F.J. Ring, “Human Body Temperature It’s Measurement and Regulation,” Plenum Press, p. 83 (date not available).
Looney, J.M., Jr., and F. Pompei, “Ear Thermometry,” *Medical Electronics*, EXE037469-EXE037474 (Jun. 1989).

Benzinger, M., “Tympanic Thermometry in Surgery and Anesthesia,” *JAMA*, 209(8): 1207-1211 (Aug. 1969).

(56)

References Cited

OTHER PUBLICATIONS

Nadel, E.R. and S.M. Horvath, "Comparison of Tympanic Membrane and Deep Body Temperature in Man," *Life Sciences*, 9(1): 869-875 (Jun. 1970).

"Memorandum and Order on Defendants' Motion for Partial Summary Judgment and on Plaintiff's Motion for Summary Judgment on S.A.A.T's Counterclaims," *Exergen Corporation v. Wal-Mart Stores, Inc., et al.* United States District Court of Massachusetts, Case No. 01-CV-10436-RCL. Jul. 14, 2004.

Pompei, F. and M. Pompei, "Arterial Thermometry Via Heat Balance at the Ear," *Medical Electronics*, (Oct. 1996).

Benzinger, T.H., "Tympanic Clinical Temperature," *Biology and Medicine*, 192: 2089-2102 (date not available).

"Deposition of Francesco Pompei, Ph.D.," *Exergen v. Wal-Mart*, Dec. 7, 2002 (Filed Under Seal).

"Deposition of Francesco Pompei, Ph.D.," *Exergen v. Wal-Mart*, Dec. 8, 2002 (Filed Under Seal).

Defendant's Trial Brief, *Exergen v. Wal-Mart*, Jun. 8, 2005, Civil Action No. 01-CV-11306-RCL (consolidated with Civil Action No. 02-CV-10436-RCL).

Judgment in a Civil Case, *Exergen v. CVS Corporation, et al.*, Aug. 4, 2005, Civil Action No. 01-11306-RCL and 02-10436-RCL.

Verdict Form, *Exergen v. S.A.A.T. Systems Application of Advanced Technology Ltd., Daiwa Products, Inc., and CVS Corporation*, Jul. 11, 2005, Civil Action No. 01-CV-11306-RCL (consolidated with Civil Action No. 02-CV-10436-RCL).

Transcript of Jury Trial Day 15, *Exergen v. S.A.A.T. Systems Application of Advanced Technology Ltd., Daiwa Products, Inc., and CVS Corporation*, Jul. 7, 2005, Civil Action No. 01-11306-RCL.

Memorandum in Support of Defendants' Motion for Judgment as a Matter of Law that Defendants do not Infringe the '813, '205, and '685 Patents as to the Safety 1st Device, the CVS Device, and the Thermotek Device, *Exergen v. Wal-Mart Stores Inc., S.A.A.T. Systems Application of Advanced Technology Ltd., Daiwa Products, Inc., and Hana Microelectronics Co, Ltd.*, Jul. 6, 2005, Civil Action No. 01-CV-11306-RCL (consolidated with Civil Action No. 02-CV-10436-RCL).

Memorandum in Support of Defendants' Motion for Judgment as a Matter of Law that Defendant SAAT does not Infringe the '813, '205, and '685 Patents, *Exergen v. Wal-Mart Stores Inc., S.A.A.T. Systems Application of Advanced Technology Ltd., Daiwa Products, Inc., and Hana Microelectronics Co, Ltd.*, Jul. 6, 2005, Civil Action No. 01-CV-11306-RCL (consolidated with Civil Action No. 02-CV-10436-RCL).

Memorandum in Support of Defendants' Motion for Judgment as a Matter of Law that Claims 1-5 of the '205 Patent are Invalid as Anticipated by the O'Hara Patent, *Exergen v. Wal-Mart Stores Inc., S.A.A.T. Systems Application of Advanced Technology Ltd., Daiwa Products, Inc., and Hana Microelectronics Co, Ltd.*, Jul. 6, 2005, Civil Action No. 01-CV-11306-RCL (consolidated with Civil Action No. 02-CV-10436-RCL).

Defendants' Motion for Judgment as a Matter of Law that Defendants do not Infringe the '813, '205 and '685 Patents as to the Safety 1st Device, the CVS Device, and the Thermotek Device, *Exergen v. Wal-Mart Stores Inc., S.A.A.T. Systems Application of Advanced Technology Ltd., Daiwa Products, Inc., and Hana Microelectronics Co, Ltd.*, Jun. 30, 2005, Civil Action No. 01-CV-11306-RCL (consolidated with Civil Action No. 02-CV-10436-RCL).

Defendants' Motion for Judgment as a Matter of Law that Defendant SAAT does not Infringe the '813, '205, and '685 Patents, *Exergen v. Wal-Mart Stores Inc., S.A.A.T. Systems Application of Advanced Technology Ltd., Daiwa Products, Inc., and Hana Microelectronics Co, Ltd.*, Jun. 30, 2005, Civil Action No. 01-CV-11306-RCL (consolidated with Civil Action No. 02-CV-10436-RCL).

Defendants' Motion for Judgment as a Matter of Law that Claims 1-5 of the '205 Patent are Invalid as Anticipated by the O'Hara Patent, *Exergen v. Wal-Mart Stores Inc., S.A.A.T. Systems Application of Advanced Technology Ltd., Daiwa Products, Inc., and Hana Micro-*

electronics Co, Ltd., Jun. 30, 2005, Civil Action No. 01-CV-11306-RCL (consolidated with Civil Action No. 02-CV-10436-RCL).

Defendants' Opposition to Plaintiff's Motion for Judgment as a Matter of Law that Defendants Infringe all Asserted Claims and are Liable for Lost Profits, *Exergen v. Wal-Mart Stores Inc., S.A.A.T. Systems Application of Advanced Technology Ltd., Daiwa Products, Inc., and Hana Microelectronics Co, Ltd.*, Jul. 21, 2005, Civil Action No. 01-CV-11306-RCL (consolidated with Civil Action No. 02-CV-10436-RCL).

Defendants' Opposition to Plaintiff's Motion for Judgment as a Matter of Law that Defendants have Failed to Prove that any Patent Claim is Invalid, *Exergen v. Wal-Mart Stores Inc., S.A.A.T. Systems Application of Advanced Technology Ltd., Daiwa Products, Inc., and Hana Microelectronics Co, Ltd.*, Jul. 21, 2005, Civil Action No. 01-CV-11306-RCL (consolidated with Civil Action No. 02-CV-10436-RCL).

Memorandum in Support of Exergen's Motion for Judgment as a Matter of Law that Defendants have Failed to Prove that any Patent Claim is Invalid, *Exergen v. Wal-Mart Stores Inc., S.A.A.T. Systems Application of Advanced Technology Ltd., Daiwa Products, Inc., and Hana Microelectronics Co, Ltd.*, Jul. 7, 2005, Civil Action No. 01-CV-11306-RCL, Civil Action No. 02-CV-10436-RCL.

Exergen's Motion for Judgment as a Matter of Law that Defendants Infringe the Patents-in-Suit and that Defendants are Liable for Exergen's Lost Profits, *Exergen v. Wal-Mart Stores Inc., S.A.A.T. Systems Application of Advanced Technology Ltd., Daiwa Products, Inc., and Hana Microelectronics Co, Ltd.*, Jul. 7, 2005, Civil Action No. 01-CV-11306-RCL, Civil Action No. 02-CV-10436-RCL.

Exergen's Motion for Judgment as a Matter of Law that Defendants have Failed to Prove that any Patent Claim is Invalid, *Exergen v. Wal-Mart Stores Inc., S.A.A.T. Systems Application of Advanced Technology Ltd., Daiwa Products, Inc., and Hana Microelectronics Co, Ltd.*, Jul. 7, 2005, Civil Action No. 01-CV-11306-RCL, Civil Action No. 02-CV-10436-RCL.

Defendant's Motion In Limine (No. 5) to Exclude any Evidence or Argument Relying Upon an Incorrect Construction of the Claim Term "Internal Temperature", *Exergen v. Wal-Mart Stores Inc., S.A.A.T. Systems Application of Advanced Technology Ltd., Daiwa Products, Inc., and Hana Microelectronics Co, Ltd.*, May 31, 2005, Civil Action No. 01-CV-11306-RCL (consolidated with Civil Action No. 02-CV-10436-RCL).

Plaintiff Exergen's Opposition to Defendants' Motions in Limine Nos. 3, 4, 5, 6 and 7, *Exergen v. Wal-Mart Stores Inc., S.A.A.T. Systems Application of Advanced Technology Ltd., Daiwa Products, Inc., and Hana Microelectronics Co, Ltd.*, Jun. 10, 2005, Civil Action No. 01-CV-11306-RCL and Civil Action No. 02-CV-10436-RCL.

Memorandum in Support of Defendants' Renewed Motion for Judgment as a Matter of Law that Claims 1-5 of the '205 Patent are Invalid as Anticipated by the O'Hara Patent, *Exergen v. Wal-Mart Stores Inc., S.A.A.T. Systems Application of Advanced Technology Ltd., Daiwa Products, Inc., and Hana Microelectronics Co, Ltd.*, Aug. 18, 2005, Civil Action No. 01-CV-11306-RCL (consolidated with Civil Action No. 02-CV-10436-RCL).

Memorandum in Support of Defendants' Renewed Motion for Judgment as a Matter of Law that Defendant SAAT did not Infringe the '813, '205, and '685 Patents, *Exergen v. Wal-Mart Stores Inc., S.A.A.T. Systems Application of Advanced Technology Ltd., Daiwa Products, Inc., and Hana Microelectronics Co, Ltd.*, Aug. 18, 2005, Civil Action No. 01-CV-11306-RCL (consolidated with Civil Action No. 02-CV-10436-RCL).

Memorandum of Points and Authorities in Support of Defendants' Renewed Motion for Judgment as a Matter of Law that Defendants do not Infringe the '813, '205, and '685 Patents as to the Safety 1st Device, the CVS Device, and the Thermotek Device, *Exergen v. Wal-Mart Stores Inc., S.A.A.T. Systems Application of Advanced Technology Ltd., Daiwa Products, Inc., and Hana Microelectronics Co, Ltd.*, Aug. 18, 2005, Civil Action No. 01-CV-11306-RCL (consolidated with Civil Action No. 02-CV-10436-RCL).

Defendants' Renewed Motion for Judgment as a Matter of Law that Defendants do not Infringe the '813, '205, and '685 Patents as to the Safety 1st Device, the CVS Device, and the Thermotek Device and Request for Oral Argument, *Exergen v. Wal-Mart Stores Inc., S.A.A.T. Systems Application of Advanced Technology Ltd., Daiwa Prod-*

(56)

References Cited

OTHER PUBLICATIONS

ucts, Inc., and Hana Microelectronics Co, Ltd., Aug. 18, 2005, Civil Action No. 01-CV-11306-RCL (consolidated with Civil Action No. 02-CV-10436-RCL).

Defendants' Renewed Motion for Judgment as a Matter of Law that Defendant SAAT did not Infringe the '813, '205, and '685 Patents and Request for Oral Argument, *Exergen v. Wal-Mart Stores Inc., S.A.A.T. Systems Application of Advanced Technology Ltd., Daiwa Products, Inc., and Hana Microelectronics Co, Ltd.*, Aug. 18, 2005, Civil Action No. 01-CV-11306-RCL (consolidated with Civil Action No. 02-CV-10436-RCL).

Defendants' Renewed Motion for Judgment as a Matter of Law that Claims 1-5 of the '205 Patent are Invalid as Anticipated by the O'Hara Patent and Request for Oral Argument, *Exergen v. Wal-Mart Stores Inc., S.A.A.T. Systems Application of Advanced Technology Ltd., Daiwa Products, Inc., and Hana Microelectronics Co, Ltd.*, Aug. 18, 2005, Civil Action No. 01-CV-11306-RCL (consolidated with Civil Action No. 02-CV-10436-RCL).

Reply Brief in Support of Defendants' Motions for Judgment as a Matter of Law, *Exergen v. Wal-Mart Stores Inc., S.A.A.T. Systems Application of Advanced Technology Ltd., Daiwa Products, Inc., and Hana Microelectronics Co, Ltd.*, Sep. 16, 2005, Civil Action No. 01-CV-11306-RCL (consolidated with Civil Action No. 02-CV-10436-RCL).

Exergen's Opposition to Defendants' Motions for Judgment as a Matter of Law (Docket Nos. 206, 208, 210, 213, 215, and 217), *Exergen v. CVS Corporation, S.A.A.T. Systems Application of Advanced Technology Ltd., and Daiwa Products, Inc.*, Sep. 6, 2005, Civil Action No. 01-CV-11306-RCL and Civil Action No. 02-CV-10436-RCL.

Defendants' Motion for Partial Summary Judgment of Noninfringement and Request for Oral Argument, *Exergen v. Wal-Mart Stores Inc., S.A.A.T. Systems Application of Advanced Technology Ltd., Daiwa Products, Inc., and Hana Microelectronics Co, Ltd.*, Apr. 15, 2003, Civil Action No. 01-CV-11306-RCL (consolidated with Civil Action No. 02-CV-10436-RCL).

Memorandum of Points and Authorities in Support of Defendants' Motion for Partial Summary Judgment of Noninfringement, *Exergen v. Wal-Mart Stores Inc., S.A.A.T. Systems Application of Advanced Technology Ltd., Daiwa Products, Inc., and Hana Microelectronics Co, Ltd.*, Apr. 15, 2003, Civil Action No. 01-CV-11306-RCL (consolidated with Civil Action No. 02-CV-10436-RCL).

Exergen's Opposition to Motion for Partial Summary Judgment of Non-Infringement, *Exergen v. Wal-Mart Stores Inc., S.A.A.T. Systems Application of Advanced Technology Ltd., Daiwa Products, Inc., and Hana Microelectronics Co, Ltd.*, *Exergen v. CVS Corporation*, May 14, 2003, Civil Action No. 01-CV-11306-RCL, Civil Action No. 02-CV-10436-RCL.

Memorandum and Order on Defendants' Motion for Partial Summary Judgment and on Plaintiff's Motion for Summary Judgment on S.A.A.T.'s Counterclaims, *Exergen v. Wal-Mart Stores Inc., S.A.A.T. Systems Application of Advanced Technology Ltd., Daiwa Products, Inc., and Hana Microelectronics Co, Ltd.*, *Exergen v. CVS Corporation*, Jul. 14, 2004, Case No. 01 CV 11306-RCL, Case No. 02-CV-10436-RCL.

Brief of Defendants—Appellants S.A.A.T. Systems Application of Advanced Technology, Ltd. and Daiwa Products, Inc., *Exergen v. Wal-Mart Stores Inc., et al.*, Dec. 5, 2008, Case No. 011-CV-11306RCL.

Brief of Plaintiff—Exergen Corporation, *Exergen v. Wal-Mart Stores Inc., et al.*, Jan. 30, 2009, Case No. 011-CV-11306RCL.

Response and Reply Brief of Defendants—Appellants S.A.A.T. Systems Application of Advanced Technology, Ltd. and Daiwa Products, Inc., *Exergen v. Wal-Mart Stores Inc., et al.*, Mar. 16, 2009, Case No. 011-CV-11306RCL.

Reply Brief for Plaintiff—Cross Appellant Exergen Corporation, *Exergen v. Wal-Mart Stores Inc., et al.*, Apr. 1, 2009, Case No. 011-CV-11306RCL.

Decision of U.S. Court of Appeals for the Federal Circuit, *Exergen v. Wal-Mart Stores Inc., et al.*, Aug. 4, 2009, Case No. 011-CV-11306RCL.

"Exhibit 3: Claim Terms and Proposed Construction," *Exergen Corporation v. Kidz-Med, Inc., et al.*, Case No. 1:08-CV-11416-DPW United States District Court for District of Massachusetts, Feb. 11, 2010.

T.K. Bergersen, "A Search for Arteriovenous Anastomoses in Human Skin Using Ultrasound Doppler," *Acta Physiol Scand*, 147: 195-201 (Feb. 1993).

Tecnimed SRL's Supplemental Preliminary Invalidation Disclosures, *Exergen Corporation v. Kidz-Med, Inc., et al.*, United States District Court for the District of Massachusetts, Civil Action No. 1:08-Cv-11416-DPW, Filed May 21, 2010.

"Exhibit A—Tecnimed SRL's Supplemental Invalidation Disclosures," *Exergen Corporation v. Kidz-Med, Inc., et al.*, United States District Court for the District of Massachusetts, Civil Action No. 1:08-Cv-11416-DPW, Filed May 21, 2010.

Newburgh, L.H., M.D., et al., "Physiology of Heat Regulation and the Science of Clothing," *Div. of Med. Sciences, Nat'l Research Council*, Preface, Chapters 2 and 3 of Part 1 (Oct. 1949).

Expert Witness Report of Jack Goldberg, *Exergen Corporation v. Wal-Mart Stores, Inc., et al.*, Civil Action No. 01-CV-11306-RCL (Jan. 17, 2003).

Symposium, "Temperature: Its Measurement and Control in Science an Industry," *American Institute of Physics, National Bureau of Standards and National Research Council*, pp. 446-452 and 537-543 (Nov. 1941).

Nadel, Ethan R., et al., "Comparison of Tympanic Membrane and Deep Body Temperature in Man," *Institute of Environmental Stress, University of California—Santa Barbara* (Jun. 1970).

European Search Report Dated Apr. 5, 2011, Application No. 10180393.0.

COMDEK publication of Thermometer in Taiwan, Magazine "Mother and Baby" vol. 259, May 1998.

Affidavit Ms. Kuo Chang, Li-Chun, dated Aug. 31, 2012, 1 page.

Comdek Manuel of Model HD-11 (14 pages), and English translation (11 pages), date unavailable.

Warranty Card Comdek HD-11, 1 page, date unavailable.

Notice of Opposition in Application No. EP99945647.8, Patent No. EP1114302, Filed Oct. 29, 2012.

Braun® Forehead Thermometer, Model FHT 1000, Operation Manual, pp. 1-23.

Vicks® Forehead Thermometer, Model V977, Use and Care Manual, pp. 1-12.

Case 1:13-cv-10628-RGS, Document 37, Filed Oct. 8, 2013, Kaz USA, Inc.'s Preliminary Invalidation and Non-Infringement Disclosures, 2 pages.

Case 1:13-cv-10628-RGS, Document 37-1, Filed Oct. 8, 2013, Exhibit I, U.S. Pat. No. 7,787,938, Invalidation Claim Chart, 8 pages.

Case 1:13-cv-10628-RGS, Document 37-2, Filed Oct. 8, 2013, Exhibit II, U.S. Pat. No. 6,292,685, Invalidation Claim Chart, 4 pages.

Case 1:13-cv-10628-RGS, Document 37-3, Filed Oct. 8, 2013, Exhibit III, U.S. Pat. No. 7,787,938, Non-Infringement Claim Chart, 9 pages.

Case 1:13-cv-10628-RGS, Document 37-4, Filed Oct. 8, 2013, Exhibit IV, U.S. Pat. No. 6,292,685, Non-Infringement Claim Chart, 4 pages.

Marybeth Pompei, Letter dated Jul. 20, 1997 to Merton Bernfield, MD.

Brooklands Inc.'s Preliminary Invalidation and Non-Infringement Contentions, *Exergen Corporation v. Brooklands Inc.*, Nov. 11, 2013, Civil Action No. 1:13-cv-12243 (DPW), Case No. 1:12-cv-12243-DPW, 28 pages (Document 31).

Exhibit A-1: Invalidation of U.S. Pat. No. 7,787,938 ("the '938 Patent") in Light of U.S. Pat. No. 5,368,038 to Fraden, Filed Mar. 8, 1993 and Issued Nov. 29, 1994 ("the '038 Patent"), *Exergen Corporation v. Brooklands Inc.*, Nov. 11, 2013, Civil Action No. 1:13-cv-12243 (DPW), Case No. 1:12-cv-12243-DPW, 929 pages (Document 31-1).

Exhibit A-18: Invalidation of U.S. Pat. No. 7,787,938 ("the '938 Patent") in Light of U.S. Pat. No. 5,012,813 to Pompei et al., Filed Apr. 14, 1989 and Issued May 7, 1991 ("the '813 Patent"), *Exergen*

(56)

References Cited

OTHER PUBLICATIONS

- Corporation v. Brooklands Inc.*, Nov. 11, 2013, Civil Action No. 1:13-cv-12243 (DPW), Case No. 1:12-cv-12243-DPW, 887 pages (Document 31-2).
- Exhibit A-34: Invalidity of U.S. Pat. No. 7,787,938 (“the ‘938 Patent”) in Light of Prior Sale and/or Public Use in the U.S. of the ThermoScan Instant Thermometer by Braun (“ThermoScan Instant Thermometer”), *Exergen Corporation v. Brooklands Inc.*, Nov. 11, 2013, Civil Action No. 1:13-cv-12243 (DPW), Case No. 1:12-cv-12243-DPW, 780 pages (Document 31-3).
- Exhibit B: Non-Infringement of U.S. Pat. No. 7,787,938 (“the ‘938 patent”) by Brooklands VeraTemp and VeraTemp+/VeraTemp Plus Thermometers in the Body Mode (Accused Brooklands Products), *Exergen Corporation v. Brooklands Inc.*, Nov. 11, 2013, Civil Action No. 1:13-cv-12243 (DPW), Case No. 1:12-cv-12243-DPW, 5 pages (Document 31-4).
- “Standard Specification for Infrared Thermometers for Intermittent Determination of Patient Temperature.” *American Society for Testing and Materials*, pp. 1-16 (1965).
- Exhibit A “Claims 1, 2, 12, 13, 22 23 and 26-29 of the ‘685 Patent Are Anticipated by Barnes,” Case 1:13-cv-10628-RGS, Document 61-1, Filed May 23, 2014, pp. 1-8.
- Exhibit B “Claims 12, 13, 22, 23 and 26 of the ‘685 Patent Are Obvious Over Barnes in View of Wortz,” Case 1:13-cv-10628-RGS, Document 61-2, Filed May 23, 2014, pp. 1-5.
- Exhibit C “Claims 12, 13, 22, 23 and 26 of the ‘685 Patent Are Obvious Over Barnes in View of Amano,” Case 1:13-cv-10628-RGS, Document 61-3, Filed May 23, 2014, pp. 1-6.
- Exhibit D “Claims 1, 2, 4, 7, 12, 13, 14, 17, 20, 21 and 30 of the ‘685 Patent and Claims 1-58, 60-62 and 64-67 of the ‘938 Patent Are Obvious Over Barnes in View of the *Physicians Reference Handbook*,” Case 1:13-cv-10628-RGS, Document 61-4, Filed May 23, 2014, pp. 1-51.
- Exhibit E “Claims 14, 17, 20-23, 26, 29 and 30 of the ‘685 Patent and Claims 1-50, 54-58, 60-62 and 64-67 of the ‘938 Patent Are Obvious Over *Physicians Reference Handbook* in View of Wortz,” Case 1:13-cv-10628-RGS, Document 61-5, Filed May 23, 2014, pp. 1-46.
- Exhibit F “Claims 14, 17, 20-23, 26, 29 and 30 of the ‘685 Patent and Claims 1-50, 54-58, 60-62, and 64-67 of the ‘938 Patent Are Obvious Over the *Physicians Reference Handbook* in View of Amano,” Case 1:13-cv-10628-RGS, Document 61-6, Filed May 23, 2014, pp. 1-47.
- Exhibit G “Claims 27 and 28 of the ‘685 Patent are anticipated by Wortz,” Case 1:13-cv-10628-RGS, Document 61-7, Filed May 23, 2014, pp. 1-2.
- Exhibit H “Claims 27 and 28 of the ‘685 Patent are anticipated by Amano,” Case 1:13-cv-10628-RGS, Document 61-8, Filed May 23, 2014, pp. 1-2.
- “Kaz, USA, Inc.’s Supplemental Invalidation Disclosures” Plaintiff: *Exergen Corporation v. Defendant/Counterclaim-Plaintiff: Kaz USA, Inc. v. Counterclaim-Defendant: Exergen Corporation*, Civil Action No. 1:13-cv-10628-RGS, Hon. Richard G. Stearns, U.S.D.J.—Jury Trial Demanded, in the United States District Court for the District of Massachusetts, pp. 1-90.
- Exergen Corporation v. Thermomedics, Inc. and Sanomedics International Holdings, Inc.*, Case 1:13-cv-11243-DJC, Document 40, Filed Jan. 21, 2014, “Joint Preliminary Invalidation Contentions of Sanomedics International Holdings, Inc. and Thermomedics, Inc.,” pp. 1-28.
- Exergen Corporation v. Thermomedics, Inc. and Sanomedics International Holdings, Inc.*, Case 1:13-cv-11243-DJC, Document 40-1, Filed Jan. 21, 2014, “Exhibit A—Claim Charts,” pp. 1-84.
- Exergen Corporation v. Thermomedics, Inc. and Sanomedics International Holdings, Inc.*, Case 1:13-cv-11243-DJC, Document 40-2, Filed Jan. 21, 2014, “Exhibit B—Claim No./Limitation ID Key and Appendices 1-10—Exemplary Prior Art Disclosures,” pp. 1-93.
- Exergen Corporation v. Thermomedics, Inc. and Sanomedics International Holdings, Inc.*, Case 1:13-cv-11243-DJC, Document 40-3, Filed Jan. 21, 2014, “Exhibit C—Declaration of Jacob Fraden, Ph.D.,” pp. 1-16.
- Amos, D., et al., “The Physiological and Cognitive Performance of Fully Acclimatised Soldiers Conducting Routine Patrol and Reconnaissance Operations in the Tropics,” Published by *DSTO Aeronautical and Maritime Research Laboratory*, Melbourne, Australia (1996), 38 pages.
- Banco, L. and Veltri, D., “Ability of Mothers to Subjectively Assess the Presence of Fever in Their Children,” *AJDC*, 138: 976-78 (Oct. 1984).
- Broca, “Communications on Localized Disease Temperature—Temperatures Morbides Locales”, *Bulletin de Academie De Medicine*, pp. 1331-1347 (1879). (foreign copy) No Abstract Available.
- Doyle, F., et al., “The effect of ambient temperature extremes on tympanic and oral temperatures,” *American Journal of Emergency Medicine*, 10(4): 285-289 (Jul. 1992).
- ECRI, “Guidance article: infrared ear thermometry,” *Health Devices*, 20(11): 431-441 (Nov. 1991).
- Esamai, F., “Comparison of Standard Mercury Thermometer and the Liquid Crystal Device Skin Contact Thermometer in Febrile Children at Eldoret District Hospital,” *East African Medical Journal*, 71(3): 193-94 (Mar. 1994).
- Fraden, J. and Lackey, R.P., “Estimation of Body Sites Temperatures from Tympanic Measurements,” *Clin. Pediatr.*, 30: 65-70 (1991).
- Gibbons, L.V., “Body temperature monitoring in the external auditory meatus,” *Aerospace Medicine*, 671-675 (Jul. 1967).
- Ikeda, T., et al., “Influence of Thermoregulatory Vasomotion and Ambient Temperature Variation on the Accuracy of Core-temperature Estimates by Cutaneous Liquid-crystal Thermometers,” *Anesthesiology*, 86(3): 603-12 (Mar. 1997).
- Jorgensen, P.F., et al., “Continuous monitoring of body temperature in pigs using non-invasive ear canal sensors,” *Acta Vet Scand.*, 27(3): 456-460 (1986).
- Love, T.J., “Thermography as an indicator of blood perfusion,” *Annals of the New York Academy of Sciences*, vol. 335: 429-437 (1980).
- Masters, J.E., “Comparison of Axillary, Oral, and Forehead Temperature,” *Archives of Disease in Childhood*, 55(11): 896-98 (1980).
- Matsukawa, T., et al., “Comparison of Distal Oesophageal Temperature with “deep” and Tracheal Temperatures,” *Canadian Journal of Anaesthesia*, 44(4): 433-38 (Dec. 1997).
- McIntosh, N., et al., “Facial Movement, Breathing, Temperature, and Affect: Implications of the Vascular Theory of Emotional Efference,” *Cognition & Emotion*, 11(2): 171-96 (1997).
- Moore, J.W. and Newbower, R.S., “Noncontact tympanic thermometer,” *Med. & Biol. Eng. & Comput.*, 16: 580-584 (1978).
- Phillips, D.B., “Physiological rationale for the ear as an ideal site for core temperature assessment,” *7th Annual Spring Head and Neck Workshop*, (Mar. 17-22, 1985), 4 pages.
- Robinson, J., et al., “Oesophageal, Rectal, Axillary, Tympanic and Pulmonary Artery Temperatures during Cardiac Surgery,” *Canadian Journal of Anaesthesia*, 45(4): 317-23 (Jan. 1998).
- Shann, F. and Mackenzie, A., “Comparison of Rectal, Axillary, and Forehead Temperatures,” *Arch. Pediatr. Adolesc. Med.*, 150: 74-78 (Jan. 1996).
- Shinozaki, T., et al., “Infrared tympanic thermometer: evaluation of a new clinical thermometer,” *Critical Care Medicine*, 16(2): 148-150 (Feb. 1988).
- Singhi, S. and Sood, V., “Reliability of Subjective Assessment of Fever by Mothers,” *Indian Pediatrics*, 27: 811-15 (Oct. 1989).
- Stener-Victorin, E., et al., “Reduction of Blood Flow Impedance in the Uterine Arteries of Infertile Women With Electro-Acupuncture,” *Human Reproduction*, 11(6): 1314-7 (Jun. 1996).
- Beuche, F., “Principles of Physics,” 3rd Ed., p. 267, Publisher: *McGraw-Hill Companies* (1977), 3 pages.
- Strong, L. and Goldman, R., “A linearized, time dependent model of heat transfer and thermoregulatory responses occurring upon immersion of cold water,” Published by *U.S. Army Research Institute of Environmental Medicine*, Natick, MA (Mar. 1982), 63 pages.
- Allen, G., et al., “Does Forehead Liquid Crystal Temperature Accurately Reflect “Core” Temperature?” *Canadian Journal of Anesthesia*, 37(6): 659-62 (1990).

(56)

References Cited

OTHER PUBLICATIONS

- White, M., "Comparison of Core Threshold Temperatures for Forehead Sweating Based on Esophageal and Rectal Temperatures," *Canadian Journal of Physiology and Pharmacology*, 71(8): 597-603 (Dec. 1992).
- Mekjavic, I.B. and Bligh, J., "Core Threshold Temperatures for Sweating," *Canadian Journal of Physiology and Pharmacology*, 67(9): 1038-44 (Jul. 1998).
- "Temperature Control Equipment—Physiologic Temperature Control," *The Aphorisms of Hippocrates*, pub AJ Valpy, London (1822), Chapter 31, 33 pages.
- Wenger, B., "Thermoregulation, Chapter 12," Published by *U.S. Army Research Institute of Environmental Medicine*, Natick, MA, 31 pages (Oct. 1997).
- Erickson, R. and Kirklin, S., "Comparison of Ear-Based, Bladder, Oral, and Axillary Methods of Core Temperature Measurement," *Critical Care Medicine*, 21(10): 1528-34 (Oct. 1993).
- Pompei, M., "Independent Assessments of Temporal Artery, An Executive Summary," *Exergen Corporation*, Watertown, MA, 4 pages, no date given.
- Coar, T., "The Aphorisms of Hippocrates with a Translation into Latin and English," pub AJ Valpy, London (1822), cover and copyright page provided.
- Graneto, J.W. and Soglin, D.F., "Maternal screening of childhood fever by palpation," *Pediatr. Emerg. Care*, 12(3): 183-4 (Jun. 1996).
- Bergeson, P.S. and Steinfield, H.J., "How dependable is palpation as a screening method for fever?" *Clin. Pediatr.*, 13: 350 (1974).
- Takehiko, I., et al., Influence of thermoregulatory vasomotion and ambient temperature variation on the accuracy of core-temperature estimates by cutaneous liquid-crystal thermometers, *Anesthesiology*, 86(3): 603-612 (Mar. 1997).
- Conrad, M.C., et al., "Thermistor recording of forehead skin temperature as an index of carotid artery disease," *Circulation*, 39(1): 126-130 (Jan. 1969).
- Burgess, G.E., III, et al., "Continuous monitoring of skin temperature using a liquid-crystal thermometer during anesthesia," *Southern Medical Journal*, 71(5): 516-518 (May 1978).
- Heinz, E.R., et al., "Experiences with Thermography in Neurologic Patients," *Annals of the New York Academy of Sciences*, 121, 177-189 (1964).
- Lees, D.E., et al., "An evaluation of liquid-crystal thermometry as a screening device for intraoperative hyperthermia," *Anesthesia & Analgesia*, 57(6): 669-674 (1978).
- Lewit, E.M., et al., "An evaluation of a plastic strip thermometer," *JAMA*, 247(3): 321-325 (1982).
- Tsuji, T., "Patient monitoring during and after open heart surgery by an improved deep body thermometer," *Medical Progress through Technology*, 12(1-2): 25-38 (1987).
- Tsuji, T., et al., "Changes in the forehead and sole deep temperature during cardiopulmonary bypass for congenital heart diseases (foreign copy, English abstract included)," *Masui—Japanese Journal of Anesthesiology*, 33(5): 532-539 (1984).
- Tsuji, T., et al., "The forehead and deep temperature monitoring with deep body thermometer in cardiac surgery (foreign copy, English abstract included)," *Nippon Kyobu Geka Gakkai Zasshi—Journal of the Japanese Association for Thoracic Surgery*, 29(6): 1029-1035 (1981).
- Tsuji, T., et al., "The forehead and sole deep temperature monitoring during cardiopulmonary bypass in open heart surgery (foreign copy, English abstract included)," *Tokyo Ika Shika Daigaku Iyo Kizai Kenkyusho Hokoku—Reports of the Institute for Medical & Dental Engineering*, Tokyo Medical & Dental University, 15: 109-114 (1981).
- Gauthier, J., et al., "Evaluation of skin temperature biofeedback training at two different sites for migraine," *J. Behav. Med.*, 4(4): 407-19 (Dec. 1981).
- Flor, H. and Turk, D.C., "Psychophysiology of chronic pain: do chronic pain patients exhibit symptom-specific psychophysiological responses?" *Psychol. Bull.*, 105(2): 215-59 (Mar. 1989).
- Fleming, D. and Feinberg, B., "Handbook of Engineering in Medicine and Biology," Published by *CRC Press, Inc.*, Cleveland, OH, p. 297 (1976).
- Avita TS2 Thermometer, *Avita Corporation*, Retrieved from the internet URL: http://www.alibaba.com/product-gs/878721123/infrared_lcd_thermometer_TS2_Series.html. [retrieved on Dec. 3, 2013]—7 pages.
- Casio Thermo Scanner TSR-100, *Casio User Manual—Module 1190—Thermo Scanner*, 6 pages, no date given.
- Clinitemp—Product Summary, *CliniTemp Medical Products*, Glenview, IL, 3 pages, no date given.
- Core-Check—Tympanic Thermometer System—Model 2090—Technical Service Manual, *IVAC Corporation*, San Diego, CA, Date of Issue: Sep. 1992, 15 pages.
- Core Temp—Model 1000, Measures Tympanic and Skin Surface Temperatures, *IMS (Intelligent Medical Systems, San Diego, CA)*, 2 pages, no date given.
- DermaTemp 1001—Infrared Thermographic Scanner, User's Manual and Reference Book, *Exergen Corporation*, Watertown, MA, 34 pages, no date given.
- Diatek 9000 Insta-Temp—Infrared Aural Thermometer, *Diatek Incorporated*, San Diego, CA, 1992, 4 pages.
- FeverScan Forehead Thermometer—Item # 13081. Retrieved from the Internet URL: <http://www.sportshealth.com/feverscan-forehead-thermometer>. [retrieved on Dec. 23, 2013]—4 pages.
- First Temp Genius Thermometer 3000A—(Sherwood Medical/Intelligent Medical Systems), *Genius 2—Tympanic Thermometer and Base, Operating Manual*, Covidien LLC, Mansfield, MA, 2011, 19 pages.
- Forehead Fever Thermometer, *Baby Tech*. Retrieved from the Internet URL: http://www.babytechint.com/bti_site.cfm?Content_ID=45. [retrieved on Dec. 16, 2013]—1 page.
- Forehead Thermometer—ATI crystal forehead thermometers provide accurate core temperatures quickly and easily. They're your ideal solution for H1N1 or pandemic kits, as well as general healthcare, hospitals and surgery centers. *American Thermal Instruments*, Dayton, OH, Version 1, Feb. 9, 2011, 2 pages.
- GentleTemp 510—Digital Ear Thermometer—Instruction Manual, *OMRON*, OMRON Healthcare Co. Ltd., Japan, 2013, 14 pages.
- GST—Graphic Stress Telethermometry, Memorial Hospital for Cancer and Allied Diseases, New York, NY, School of Radiologic Technology, Apr. 1978, 69 pages.
- Infrared Scanner OS91—Digital Infrared Temperature Scanner with Automatic Emissivity Compensation, *Omega*, Stamford, CT. Retrieved from the Internet URL: <http://www.omega.com/pptst/os91.html>. [retrieved on Dec. 10, 2013]—2 pages.
- LighTouch LTN Axillary Thermometer, *Exergen Corporation*, Watertown, MA. Retrieved from the Internet URL: <http://www.exergen.com/medical/product/LTNhome1.html>. [retrieved on Dec. 10, 2013]—1 page.
- LighTouch LTX—Ear/Tympanic Thermometer and Pedi-Q, *Exergen Corporation*, Watertown, MA. Retrieved from the Internet URL: <http://www.exergen.com/medical/product/LTXhome1.html>. [retrieved on Dec. 10, 2013]—1 page.
- Microscanner D-Series—Instruction Manual, *Exergen Corporation*, Watertown, MA, 13 pages, no date given.
- Mon-a-therm 1000—Skin Temperature Monitor—Manufacturer Specifications, *Mallinckrodt Puritan Bennett*. Retrieved from the Internet URL: <http://www.medwow.com/med/thermometer/mallinckrodt-puritan-bennett/mon-a-therm-1...> [retrieved on Dec. 10, 2013]—2 pages.
- Omega OS9X, User's Guide, *OSP Series Portable IR Thermometers*, *Omega Engineering, Inc.*, Stamford, CT, 60 pages, 1999.
- Omega 583X, Operator's Manual M1492/0792, OS91 and OS92, *Infrared Scanners*, *Omega Engineering, Inc.*, Stamford, CT, 24 pages, 1991.
- Ototemp—Core Temperature with Striking Speed and Accuracy, *Exergen Corporation*, Watertown, MA. Retrieved from the Internet URL: <http://www.exergen.com/medical/product/OtotempVet.html>. [retrieved on Dec. 10, 2013]—2 pages.
- Phillips Thermographic Pencil, *Phillips Bio-Medical, Inc.*, San Diego, CA, 1981, 4 pages.

(56) **References Cited**

OTHER PUBLICATIONS

Pro-1 Infrared Thermometer (Thermoscan), Thermo Works, Lindon, UT. Retrieved from the Internet URL: <http://www.thermoworks.com/products/ir/irpro.html>. [retrieved on Dec. 10, 2013]—6 pages.

3M Tempa-DOT—Single-Use Clinical Thermometers, 3M Health Care, Ontario, Canada, 1997, 2 pages.

Tempteller Infrared Ear Thermometer, Model CT-30/CT-30DX, Oriental System Technology Inc., Great Neck, NY, 510(k) Summary and Letter to S.D. Goldstein-Falk from T.A. Ulatowski dated Jul. 9, 2001, 6 pages.

Thermoscan Instant Thermometer, IRT 1020, Type 6005, Home Model—HM2/Thermoscan EZ/Thermoscan Pro-2000/Pro-3000/Thermoscan IRT 3020/3520, Braun GmbH, Kronberg, Germany, 10 pages, no date given.

Thermophil 4410, Ultrakust, Germany, Geratebau O. Raudszus; Ruhmannsfelden. Retrieved from the Internet URL: http://www.radiomuseum.org/r/ultrakust_thermophil_4410.html. [retrieved on Dec. 10, 2013]—2 pages.

Excerpts from Jacob Fraden, Ph.D.'s Notebooks, Various Dates prior to Jun. 1989—4 pages.

FirstTemp Genius—Portrait of a Contemporary Classic—Sherwood Medical, St. Louis, MO, 1993, 8 pages.

Gray's Anatomy of the Human Body, *Anatomy, Descriptive and Surgical*, by Henry Gray, F.R.S., *Bounty Books*, New York, from the 15th English Edition (1977), title pages and table of contents provided.

Exergen Corporation v. Kaz USA, Inc. v. Exergen Corporation, Case 1:13-cv-10628-RGS, Document 37, Filed Oct. 8, 2013, "Kaz USA, Inc.'s Preliminary Invalidity and Non-Infringement Disclosures," pp. 1-2.

Exergen Corporation v. Kaz USA, Inc. v. Exergen Corporation, Case 1:13-cv-10628-RGS, Document 37-1, Filed Oct. 8, 2013, "Exhibit I—U.S. Pat. No. 7,787,938 Invalidity Claim Chart," pp. 1-8.

Exergen Corporation v. Kaz USA, Inc. v. Exergen Corporation, Case 1:13-cv-10628-RGS, Document 37-2, Filed Oct. 8, 2013, "Exhibit II—U.S. Pat. No. 6,292,685 Invalidity Claim Chart," pp. 1-4.

Exergen Corporation v. Kaz USA, Inc. v. Exergen Corporation, Case 1:13-cv-10628-RGS, Document 37-3, Filed Oct. 8, 2013 "Exhibit III—U.S. Pat. No. 7,787,938 Non-Infringement Claim Chart," pp. 1-9.

Exergen Corporation v. Kaz USA, Inc. v. Exergen Corporation, Case 1:13-cv-10628-RGS, Document 37-4, Filed Oct. 8, 2013, "Exhibit IV—U.S. Pat. No. 6,292,685 Non-Infringement Claim Chart," pp. 1-4.

Letter to Dr. Bernfield dated Jul. 20, 1997 from Marybeth Pompei, 1 page.

Exergen Corporation v. Brooklands Inc., Case 1:12-cv-12243-DPW, Document 47, Filed Feb. 26, 2014, "Defendant Brooklands Inc.'s Memorandum of Law in Support of its Motion for Summary Judgment of Invalidity Under 35 U.S.C. § 101," pp. 1-14.

Instructions, "Quick Start Guide for Forehead Thermometer," Model V977, Kaz, Inc., 2008, pp. 1-11.

Brooklands Inc.'s Preliminary Invalidity and Non-Infringement Contentions, *Exergen Corporation v. Brookland's Inc.*, United States District Court for the District of Massachusetts, Civil Action No. 1:12-cv-12243-DPW, filed Nov. 11, 2013.

Defendant Brooklands Inc.'s Motion for Summary Judgment of Invalidity Under 35 U.S.C. §101, *Exergen Corporation v. Brooklands, Inc.*, United States District Court for the District of Massachusetts, Civil Action No. 1:12-cv-12243—Jury Trial Demanded, filed Feb. 26, 2014.

Defendant Brooklands Inc.'s Memorandum of Law in Support of Its Motion for Summary Judgment of Invalidity Under 35 U.S.C. §101, *Exergen Corporation v. Brooklands, Inc.*, United States District Court for the District of Massachusetts, Civil Action No. 1:12-cv-12243—Jury Trial Demanded, filed Feb. 26, 2014.

Defendant Brooklands Inc.'s Rule 56.1 Concise Statement of Material Facts in Support of Its Motion for Summary Judgment of Invalidity Under 35 U.S.C. §101, *Exergen Corporation v. Brooklands,*

Inc., United States District Court for the District of Massachusetts, Civil Action No. 1:12-cv-12243—Jury Trial Demanded, filed Feb. 26, 2014.

Declaration of James L. Lukas, Jr. In Support of Defendant Brooklands Inc.'s Motion for Summary Judgment of Invalidity Under 35 U.S.C. §101, *Exergen Corporation v. Brooklands, Inc.*, United States District Court for the District of Massachusetts, Civil Action No. 1:12-cv-12243—Jury Trial Demanded, filed Feb. 26, 2014.

Exergen's Opposition to Brookland's Motion for Summary Judgment of Invalidity Under 35 U.S.C. §101, *Exergen Corporation v. Brooklands, Inc.*, United States District Court District of Massachusetts, Civil Action No. 1:13-cv-12243-DPW, filed Mar. 19, 2014.

Exergen's Rule 56.1 Statement of Material Facts in Opposition to Brookland's Motion Summary Judgment of Invalidity Under 35 U.S.C. §101, *Exergen Corporation v. Brooklands, Inc.*, United States District Court District of Massachusetts, Civil Action No. 1:12-cv-12243-DPW, filed Mar. 19, 2104.

Defendant Brooklands Inc.'s Reply in Support of its Motion for Summary Judgment of Invalidity Under 35 U.S.C. §101, *Exergen Corporation v. Brooklands, Inc.*, Civil Action No. 1:12-cv-12243 Jury Trial Demanded, filed Apr. 2, 2014.

Defendant Brooklands Inc.'s Response to Exergen's Rule 56.1 Statement of Material Facts in Opposition to Brookland's Motion for Summary Judgment of Invalidity Under 35 U.S.C. §101, *Exergen Corporation v. Brooklands, Inc.*, United States District Court for the District of Massachusetts, Civil Action No. 1:12-cv-12243—Jury Trial Demanded, filed Mar. 19, 2014.

Defendant Brooklands Inc.'s Response to Exergen's Rule 56.1 Statement of Material Facts in Opposition to Brookland's Motion for Summary Judgment of Invalidity Under 35 U.S.C. §101, *Exergen Corporation v. Brooklands, Inc.*, United States District Court for the District of Massachusetts, Civil Action No. 1:12-cv-12243—Jury Trial Demanded, filed Apr. 2, 2014.

Exergen's Surreply in Opposition to Brookland's Motion for Summary Judgment of Invalidity Under 35 U.S.C. §101, *Exergen Corporation v. Brooklands, Inc.*, United States District Court for the District of Massachusetts, Civil Action No. 1:12-cv-12243—Jury Trial Demanded, filed Apr. 24, 2014.

Defendant Brookland Inc.'s Notice of Supplemental Authority in Support of its Motion for Summary Judgment of Invalidity under 35 U.S.C. §101, *Exergen Corporation v. Brooklands, Inc.*, United States District Court for the District of Massachusetts, Civil Action No. 1:12-cv-12243—Jury Trial Demanded, filed Jun. 25, 2014.

Exergen's Response to Brookland's Notice of Supplemental Authority Regarding Summary Judgment of Invalidity Under §101, *Exergen Corporation v. Brooklands, Inc.*, United States District Court for the District of Massachusetts, Civil Action No. 1:12-cv-12243—Jury Trial Demanded, filed Jul. 3, 2014.

Defendant Brooklands Inc.'s Notice of Supplemental Authority in Support of its Motion for Summary Judgment of Invalidity Under 35 U.S.C. §101, *Exergen Corporation v. Brooklands, Inc.*, United States District Court for the District of Massachusetts, Civil Action No. 1:12-cv-12243—Jury Trial Demanded, filed Aug. 22, 2014.

Exergen's Response to Brookland's Second Notice of Supplemental Authority Regarding Summary Judgment of Invalidity Under U.S.C. §101, *Exergen Corporation v. Brooklands, Inc.*, United States District Court for the District of Massachusetts, Civil Action No. 1:12-cv-12243—Jury Trial Demanded, filed Aug. 28, 2014.

Defendant Brookland Inc.'s Motion for Summary Judgment of Invalidity Under 35 U.S.C. §§102 and/or 103, *Exergen Corporation v. Brooklands, Inc.*, United States District Court for the District of Massachusetts, Civil Action No. 1:12-cv-12243—Jury Trial Demanded, filed Sep. 19, 2014.

Defendant Brooklands Inc.'s Memorandum of Law in Support of its Motion for Summary Judgment of Invalidity Under 35 U.S.C. §§ 102 and/or 103, *Exergen Corporation v. Brooklands, Inc.*, United States District Court for the District of Massachusetts, Civil Action No. 1:12-cv-12243—Jury Trial Demanded, filed Sep. 19, 2014.

Declaration of James J. Lukas, Jr. in Support of Defendant Brooklands Inc.'s Rule 56.1 Concise's Statement of Material Facts in Support of Motion for Summary Judgment of Invalidity Under 35

(56)

References Cited

OTHER PUBLICATIONS

U.S.C. §§102 and/or 103, *Exergen Corporation v. Brooklands, Inc.*, United States District Court for the District of Massachusetts, Civil Action No. 1:12-cv-12243—Jury Trial Demanded, filed Sep. 19, 2014.

Exergen Corporation's Opposition to Defendant Brooklands' Motion for Summary Judgment of Invalidity Under 35 U.S.C. §§102 and/or 103, *Exergen Corporation v. Brooklands, Inc.*, United States District Court for the District of Massachusetts, Civil Action No. 1:12-cv-12243—Jury Trial Demanded, filed Oct. 17, 2014.

Exergen's Rule 56.1 Statement of Material Facts in Opposition to Brookland's Motion for Summary Judgment of Invalidity Under 35 U.S.C. §102 and/or 103, *Exergen Corporation v. Brooklands, Inc.*, United States District Court for the District of Massachusetts, Civil Action No. 1:12-cv-12243—Jury Trial Demanded, filed Oct. 17, 2014.

Defendant Brooklands Inc.'s Reply in Support of its Motion for Summary Judgment of Invalidity Under 35 U.S.C. §§102 and/or 103, *Exergen Corporation v. Brooklands, Inc.*, United States District Court for the District of Massachusetts, Civil Action No. 1:12-cv-12243—Jury Trial Demanded, filed Oct. 31, 2014.

Brooklands Inc.'s Response to Exergen's Rule 56.1 Statement of Material Facts in Opposition to Brookland's Inc.'s Motion for Summary Judgment of Invalidity Under 35 U.S.C. §102 and/or 103, *Exergen Corporation v. Brooklands, Inc.*, United States District Court for the District of Massachusetts, Civil Action No. 1:12-cv-12243—Jury Trial Demanded, filed Oct. 31, 2014.

Declaration of James J. Lukas, Jr. in Support of Defendant Brooklands Inc.'s Response to Exergen Corporation's Rule 56.1 Statement of Material Facts in Opposition to Brookland Inc.'s Motion for Summary Judgment of Invalidity Under 35 U.S.C. §§ 102 and/or 103, *Exergen Corporation v. Brooklands, Inc.*, United States District Court for the District of Massachusetts, Civil Action No. 1:12-cv-12243—Jury Trial Demanded, filed Oct. 31, 2014.

Exergen's Motion for Leave to File Surreply Memorandum in Support of Its Opposition to Brookland's Motion for Summary Judgment of Invalidity Under U.S.C. §§102 and/or 103, *Exergen Corporation v. Brooklands, Inc.*, United States District Court for the District of Massachusetts, Civil Action No. 1:12-cv-12243—Jury Trial Demanded, filed Dec. 11, 2014.

Exergen's Sur-reply in Opposition to Brooklands' Motion for Summary Judgment of Invalidity Under 35 U.S.C. §§ 102 and/or 103, *Exergen Corporation v. Brooklands, Inc.*, United States District Court for the District of Massachusetts, Civil Action No. 1:12-cv-12243—Leave to File Granted on Dec. 11, 2014, filed Dec. 11, 2014.

Exergen's Assented-To Motion for Leave to File Supplemental Opposition to Brookland's Motion for Summary Judgment of Invalidity Under 35 U.S.C. §101, *Exergen Corporation v. Brooklands, Inc.*, United States District Court District of Massachusetts, Civil Action No. 1:12-cv-12243-DPW, filed May 27, 2015.

Motions Taken Under Advisement: [106] Motion for Sanctions [Rule 11], [88] Motion for Summary Judgment of Invalidity Under 35 USC 102 and/or 103, [46] Motion for Summary Judgment of Invalidity Under 35 U.S.C. Sec. 101 (Lovett, Jarrett), *Exergen Corporation v. Brooklands, Inc.*, United States District Court, District of Massachusetts, Civil Action No. 1:12-cv-12243-DPW, entered on Dec. 23, 2014 and filed on Dec. 17, 2014.

Motion Hearing held on Dec. 17, 2014 re [106] Motion for Sanction [Rule 11] filed by Brooklands Inc., [88] Motion for Summary Judgment of Invalidity Under 35 USC 102 and/or 103 filed by Brooklands Inc., [46] Motion for Summary Judgment of Invalidity Under 35 U.S.C. Sec. 101 filed by Brooklands Inc. Court hears arguments on motions and takes them under advisement.

Exergen's Assented-To Motion for Leave to File Supplemental Opposition to Brookland's Motion for Summary Judgment of Invalidity Under 35 U.S.C. §101, *Exergen Corporation v. Brooklands, Inc.*, United States District Court, District of Massachusetts, Civil Action No. 1:12-cv-12243-DPW, filed on May 27, 2015.

Kaz USA, Inc.'s Preliminary Invalidity and Non-Infringement Disclosures, *Exergen Corporation v. Kaz USA, Inc. v. Exergen Corpo-*

ration., In the United States District Court for the District of Massachusetts, Civil Action No. 1:13-cv-10628-RGS, Hon. Richard G. Stearns, U.S.D.J., Jury Trial Demand, filed Oct. 8, 2013.

Kaz USA, Inc.'s Supplemental Invalidity Disclosures, *Exergen Corporation v. Kaz USA, Inc. v. Exergen Corporation.*, In the United States District Court for the District of Massachusetts, Civil Action No. 1:13-cv-10628-RGS, Hon. Richard G. Stearns, U.S.D.J., Jury Trial Demanded, filed May 23, 2014.

Exergen's Motion for Summary Judgment of No Inequitable Conduct, *Exergen Corporation v. Kaz USA, Inc.*, United States District Court District of Massachusetts, Civil Action No. 1:13-cv-10628-RGS, filed May 26, 2015.

Exergen's Memorandum in Support of Its Motion for Summary Judgment of Inequitable Conduct, *Exergen Corporation v. Kaz USA, Inc.*, United States District Court District of Massachusetts, Civil Action No. 1:13-cv-10628-RGS, filed May 26, 2015.

Kaz's Motion for Summary Judgment of Invalidity due to Obviousness, *Exergen Corporation v. Kaz USA, Inc. v. Exergen Corporation.*, In the United States District Court for the District of Massachusetts, Civil Action No. 1:13-cv-10638-RGS, Hon. Richard G. Stearns, U.S. D.J., Jury Trial Demanded, filed May 26, 2015.

Kaz USA, Inc.'s Local Rule 56.1 Concise Statement of Material Facts in Support of its Motion for Summary Judgment [filed under Seal by Kaz on May 26, 2015], *Exergen Corporation v. Kaz USA, Inc. v. Exergen Corporation.*, In the United States District Court for the District of Massachusetts, Civil Action No. 1:13-cv-10628-RGS, Hon. Richard G Stearns, U.S.D.J., Jury Trial Demanded, filed May 26, 2015.

Declaration of H. Frederick Bowman in Support of Kaz's Summary Judgment Motions, In the United States District Court for the District of Massachusetts, *Exergen Corporation v. Kaz USA, Inc. v. Exergen Corporation.*, Civil Action No. 1:13-cv-10628-RGS, Hon. Richard G. Stearns, U.S.D.J., Jury Trial Demanded, filed May 26, 2015.

Kaz's Memorandum of Reasons in Support of its Motion for Summary Judgment of Invalidity due to Obviousness, *Exergen Corporation v. Kaz USA, Inc. v. Exergen Corporation.*, In the United States District Court for the District of Massachusetts, Civil Action No. 1:13-cv-10628-RGS, Hon. Richard G. Stearns, U.S.D.J., Jury Trial Demanded, filed May 26, 2015.

Declaration of Stephen Underwood in Support of Kaz's Summary Judgment Motions, *Exergen Corporation v. Kaz USA, Inc. v. Exergen Corporation.*, In the United States District Court for the District of Massachusetts, Civil Action No. 1:13-cv-10628-RGS, Hon. Richard G. Stearns, U.S.D.J. Jury Trial Demanded, filed May 26, 2015.

Declaration of Frances Pompei, Ph.D. in Opposition to Kaz USA, Inc.'s Motions for Summary Judgment, *Exergen Corporation v. Kaz USA, Inc.*, United States District Court District of Massachusetts, Civil Action No. 1:13-cv-10628-RGS, Redacted Copy for Public Filing, filed Jun. 16, 2015.

Declaration of Brandon Scruggs in Support of Exergen Corporation's Oppositions to Kaz's Summary Judgment Motions, *Exergen Corporation v. Kaz USA, Inc.*, United States District Court District of Massachusetts, Civil No. 1:13-cv-10628-RGS, filed Jun. 16, 2015.

Exergen's Rule 56.1 Counter-Statement of Material Facts in Opposition to Kaz USA, Inc.'s Motions for Summary Judgment, *Exergen Corporation v. Kaz USA, Inc.*, Civil Action No. 1:13-cv-10628-RGS, Oral Argument Required, Redacted Copy for Public Filing, Filed Jun. 16, 2015.

Kaz's Opposition to Exergen's Motion for Summary Judgment of No Inequitable Conduct, [Filed Under Seal by Kaz on Jun. 16, 2015], *Exergen Corporation v. Kaz USA, Inc. v. Exergen Corporation.*, In the United States District Court for the District of Massachusetts, Civil Action No. 1:13-cv-10628-RGS, Hon. Richard G. Stearns, U.S.D.J., Filed under granted on Jun. 16, 2015.

Kaz USA, Inc.'s Local Rule 56.1 Response to Exergen's Statement of Undisputed Facts in Support of its Motion for Summary Judgment of no Inequitable Conduct, Filed Under Seal by Kaz on Jun. 16, 2015, *Exergen Corporation v. Kaz USA, Inc. v. Exergen Corporation.*, In the United States District Court for the District of Massachusetts, Civil Action No. 1:13-cv-10628-RGS, Hon. Richard G. Stearns, U.S.D.J., Jury Trial Demanded, filed Jun. 16, 2015.

Kaz USA, Inc.'s Local Rule 56.1 Response to Exergen's Statement of Undisputed Facts in Support of its Motion for Summary Judgment of

(56)

References Cited

OTHER PUBLICATIONS

no Inequitable Conduct Filed Under Seal by Kaz on Jun. 16, 2015, *Exergen Corporation v. Kaz USA, Inc. v. Exergen Corporation*, In the United States District Court for the District of Massachusetts, Civil Action No. 1:13-cv-10628-RGS, Hon. Richard G. Stearns, U.S.D.J., Jury Trial Demanded, Redacted Copy for Public Filing, filed Jun. 17, 2015.

Declaration of Stephen Underwood in Opposition to Exergen's Summary Judgment Motions, *Exergen Corporation v. Kaz USA, Inc. v. Exergen Corporation*, In the United States District Court for the District of Massachusetts, Civil Action No. 1:13-cv-10628-RGS, Hon. Richard G. Stearns, U.S.D.J., Jury Trial Demanded, Filed Jun. 16, 2015.

Kaz's Opposition to Exergen's Motion for Summary Judgment of No Inequitable Conduct, *Exergen Corporation v. Kaz USA, Inc. v. Exergen Corporation*, Civil Action No. 1:13-cv-1068-RGS, Hon. Richard G. Stearns, U.S.D.J., Jury Trial Demanded, Redacted Copy for Public Filing, Filed Jun. 17, 2015.

Exergen's Opposition to Kaz's Motion for Summary Judgment of Invalidity Due to Obviousness, *Exergen Corporation v. Kaz USA, Inc.*, United States District Court District of Massachusetts, Civil Action No. 1:13-cv-10628-RGS, Oral Argument Requested (Redacted Copy for Public Filing), filed Jun. 16, 2015.

Exergen's Reply in Support of Its Motion for Summary Judgment of No Inequitable Conduct, *Exergen Corporation v. Kaz USA, Inc.*, United States District Court District of Massachusetts, Civil Action No. 1:13-cv-10628-RGS, Oral Argument Requested, Leaved to file granted on Jun. 23, 2015 [D.N. 193], filed Jul. 7, 2015.

Kaz's Reply Brief in Support of Its Motion for Summary Judgment of Invalidity Due to Obviousness, *Exergen Corporation v. Kaz USA, Inc. v. Exergen Corporation*, United States District Court District of Massachusetts, Civil Action No. 1:13-cv-10628-RGS, Jury Trial Demanded, [Leave to file granted on Jun. 23, 2015. D.I. 193], Jul. 7, 2015.

Supplemental Declaration of Stephen Underwood in Support of Kaz's Summary Judgment Motions, *Exergen Corporation v. Kaz USA, Inc. v. Exergen Corporation*, United States District Court District of Massachusetts, Civil Action No. 1:13-cv-10628-RGS, Hon. Richard G. Stearns, U.S.D.J., Jury Trial Demanded, [Leave to file reply granted on Jun. 23, 2015, D.I. 193], filed Jul. 7, 2015.

Exergen's Surreply in Opposition to Kaz's Motion for Summary Judgment of Invalidity Due to Obviousness, *Exergen Corporation v. Kaz USA, Inc.*, United States District Court District of Massachusetts, Civil Action No. 1:13-cv-10628-RGS, Leave to File Granted on Jul. 20, 2015 [D.N. 226], filed Jul. 24, 2015.

Sanomedics International Holdings, Inc.'s Preliminary Non-Infringement Contentions, *Exergen Corporation v. Thermomedics, Inc. and Sanomedics International Holdings, Inc.*, United States District Court District of Massachusetts, Civil Action No. 1:13-cv-11243-DJC, filed Jan. 21, 2014.

Thermomedics, Inc.'s Preliminary Non-Infringement Contentions, *Exergen Corporation v. Thermomedics, Inc. and Sanomedics International Holdings, Inc.*, United States District Court District of Massachusetts, Civil Action No. 1:13-cv-11243-DJC, filed Jan. 21, 2014.

Joint Preliminary Invalidity Contentions of Sanomedics International Holdings, Inc. and Thermomedics, Inc., *Exergen Corporation v. Thermomedics, Inc. and Sanomedics International Holdings, Inc.*, United States District Court District of Massachusetts, Civil Action No. 1:13-cv-11243-DJC, filed Jan. 21, 2014.

Thermomedics, Inc.'s and Sanomedics International Holdings, Inc.'s Supplemental Non-Infringement Contentions, *Exergen Corporation v. Thermomedics, Inc. and Sanomedics International Holdings, Inc.*, United States District Court District of Massachusetts, Civil Action No. 1:13-cv-11243-DJC, filed Oct. 1, 2014.

Joint Supplemental Invalidity Contentions of Sanomedics International Holdings, Inc., and Thermomedics, Inc., *Exergen Corporation v. Thermomedics, Inc. and Sanomedics International Holdings, Inc.*, United States District Court District of Massachusetts, Civil Action No. 1:13-cv-11243-DJC, filed Oct. 1, 2014.

Defendants Thermomedics, Inc. and Sanomedics International Holdings, Inc.'s Motion for Summary Judgment of Invalidity Under 35 U.S.C. §101, *Exergen Corporation v. Thermomedics, Inc. and Sanomedics International Holdings, Inc.*, United States District Court for the District of Massachusetts, Case No. 13-cv-11243-DJC, filed Dec. 23, 2014.

Defendants Rule 56.1 Concise Statement of Material Facts in Support of their Motion for Summary Judgment of Invalidity Under 35 U.S.C. §101 and Motion for Summary Judgment of Invalidity Under 35 U.S.C. §§102 and 103, *Exergen Corporation v. Thermomedics, Inc. and Sanomedics International Holdings, Inc.*, United States District Court for the District of Massachusetts, Case No. 13-cv-11243-DJC, filed Dec. 23, 2014.

Declaration of Timothy Devlin Regarding Defendant's Combined Memorandum in Support of Their Motion for Summary Judgment of Invalidity Under 35 U.S.C. §101 and Motion for Summary Judgment of Invalidity Under 35 U.S.C. §§102 and 103, *Exergen Corporation v. Thermomedics, Inc. and Sanomedics International Holdings, Inc.*, United States District Court for the District of Massachusetts, Case No. 13-cv-11243-DJC, filed Dec. 23, 2014.

Defendants Combined Memorandum of Law in Support of Their Motion for Summary Judgment of Invalidity Under 35 U.S.C. §101 and Motion for Summary Judgment of Invalidity Under 35 U.S.C. §§102 and 103, *Exergen Corporation v. Thermomedics, Inc. and Sanomedics International Holdings, Inc.*, United States District Court for the District of Massachusetts, Case No. 13-cv-11243-DJC, filed Dec. 24, 2014.

Exergen Corporation's Opposition to Defendants Motion for Summary Judgment of Invalidity Under 35 U.S.C. §§102 and/or 103, *Exergen Corporation v. Thermomedics, Inc. and Sanomedics International Holdings, Inc.*, United States District Court for the District of Massachusetts, Case No. 13-cv-11243-DJC, filed Jan. 26, 2015.

Declaration of Francesco Pompei, Ph.D. in Opposition to Defendants Motion for Summary Judgment of Invalidity Under 35 U.S.C. §§102 and/or 103, *Exergen Corporation v. Thermomedics, Inc. and Sanomedics International Holdings, Inc.*, United States District Court for the District of Massachusetts, Case No. 13-cv-11243-DJC, filed Jan. 26, 2015.

Exergen's Opposition to Sanomedic's Motion for Summary Judgment of Invalidity Under 35 U.S.C. §101, *Exergen Corporation v. Thermomedics, Inc. and Sanomedics International Holdings, Inc.*, United States District Court for the District of Massachusetts, Case No. 13-cv-11243-DJC, filed Jan. 26, 2015.

Exergen's Rule 56.1 Statement of Material Facts in Opposition to Defendants' Motions for Summary Judgment Under 35 U.S.C. § 101 and Under 35 U.S.C. §§ 102 and/or 103, *Exergen Corporation v. Thermomedics, Inc. and Sanomedics International Holdings, Inc.*, United States District Court for the District of Massachusetts, Case No. 13-cv-11243-DJC, filed Jan. 26, 2015.

Defendant's Combined Reply Memorandum of Law in Support of Their Motion for Summary Judgment of Invalidity Under 35 U.S.C. § 101 and Motion for Summary Judgment of Invalidity Under 35 U.S.C. §§ 102 and 103, *Exergen Corporation v. Thermomedics, Inc. and Sanomedics International Holdings, Inc.*, United States District Court for the District of Massachusetts, Case No. 13-cv-11243-DJC, filed Feb. 17, 2015.

Defendants Response to Exergen's Rule 56.1 Statements of Material Facts in Opposition to Defendants' Motions for Summary Judgment Under 35 U.S.C. § 101 and Under 35 U.S.C. § 102 and 103, *Exergen Corporation v. Thermomedics, Inc. and Sanomedics International Holdings, Inc.*, United States District Court for the District of Massachusetts, Case No. 13-cv-11243-DJC, filed Feb. 17, 2015.

Declaration of Timothy Devlin Regarding Defendant's Combined Reply Memorandum of Law in Support of Their Motion for Summary Judgment of Invalidity Under 35 U.S.C. § 101 and Motion for Summary Judgment of Invalidity Under 35 U.S.C. §§ 102 and 103, *Exergen Corporation v. Thermomedics, Inc. and Sanomedics International Holdings, Inc.*, United States District Court for the District of Massachusetts, Case No. 13-cv-11243-DJC, filed Feb. 17, 2015. Notice of Electronic Filing—Electronic Clerk's Notes for proceedings held before Judge Denise J. Casper: Motion Hearing held on Apr. 30, 2015 re [84] Motion for Summary Judgment of Invalidity Under 35 U.S.C. § 102 and/or 103 filed by Thermomedics, Inc., Sanomedics

(56)

References Cited

OTHER PUBLICATIONS

International Holdings, Inc., [83] Motion for Summary Judgment of Invalidity Under 35 U.S.C. § 101 filed by Thermomedics, Inc., Sanomedics International Holdings, Inc. Arguments, Court takes under advisement [83] Motion for Summary Judgment; takes under advised [84] Motion for Summary Judgment; *Exergen Corporation v. Thermomedics, Inc. et al.*, United States District Court, District of Massachusetts, Case No. 1:13-cv-11243-DJC, filed Apr. 30, 2015.

Judgment, *Exergen Corporation v. Brooklands Inc.*, United States District Court for the District of Massachusetts, Civil Action No. 12-12243-DPW, Filed Aug. 28, 2015.

Memorandum and Order, *Exergen Corporation v. Brooklands Inc.*, United States District Court for the District of Massachusetts, Civil Action No. 12-12243-DPW, Filed Aug. 28, 2015.

Memorandum and Order, *Exergen Corp. v. Thermomedics, Inc., et al.*, United States District Court for the District of Massachusetts, Civil Action No. 13-11243-DJC, filed Sep. 15, 2015.

Exergen Corporation's Complaint for Patent Infringement and Demand for Jury Trial, *Exergen Corporation v. Microlife Corporation*, United States District Court District of Massachusetts, Jury Trial Demanded, Civil Action No. 1:15-cv-13387-RGS, filed Sep. 18, 2015.

Exhibit A to Exergen Corporation's Complaint for Patent Infringement and Demand for Jury Trial, *Exergen Corporation v. Microlife Corporation*, United States District Court District of Massachusetts, Jury Trial Demanded, Civil Action No. 1:15-cv-13387-RGS, filed Sep. 18, 2015.

Exhibit B to Exergen Corporation's Complaint for Patent Infringement and Demand for Jury Trial, *Exergen Corporation v. Microlife Corporation*, United States District Court District of Massachusetts, Jury Trial Demanded, Civil Action No. 1:15-cv-13387-RGS, filed Sep. 18, 2015.

* cited by examiner

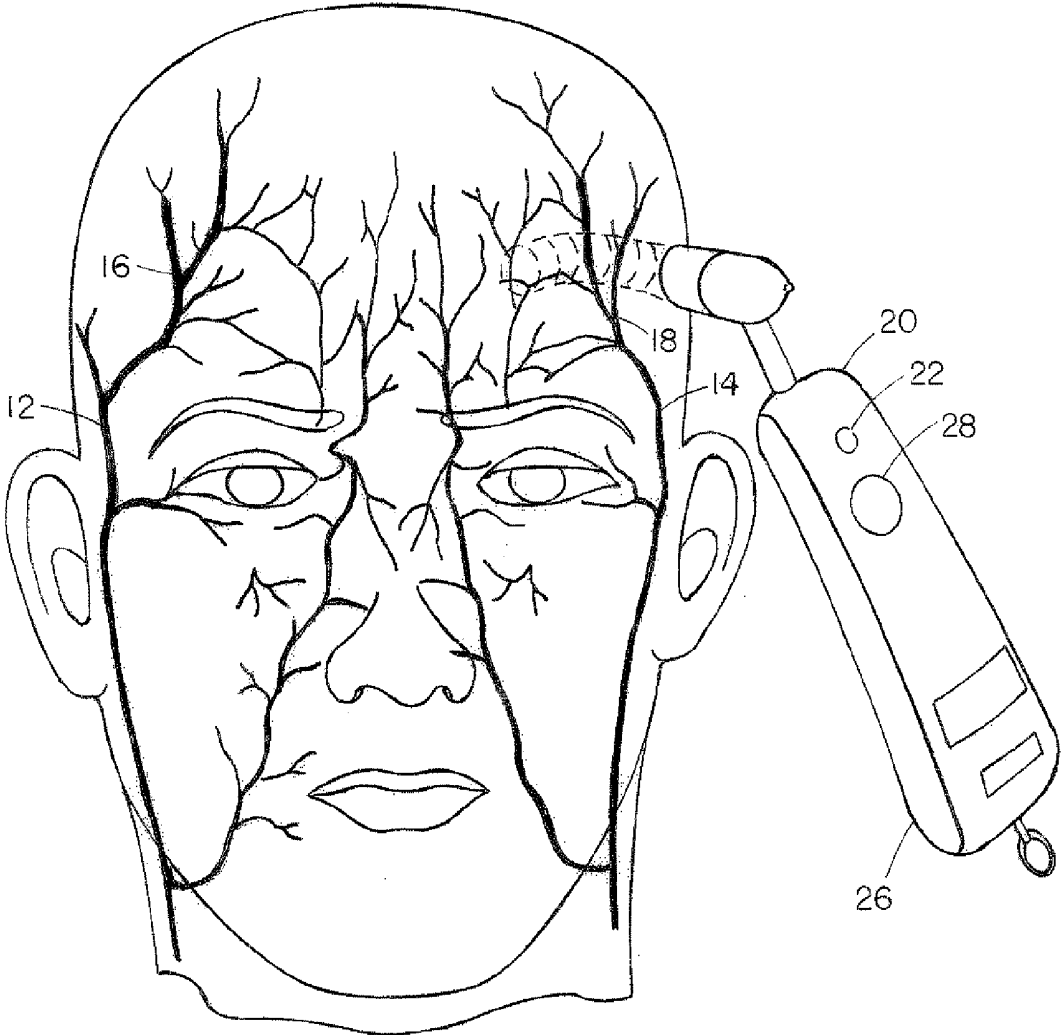

FIG. 1

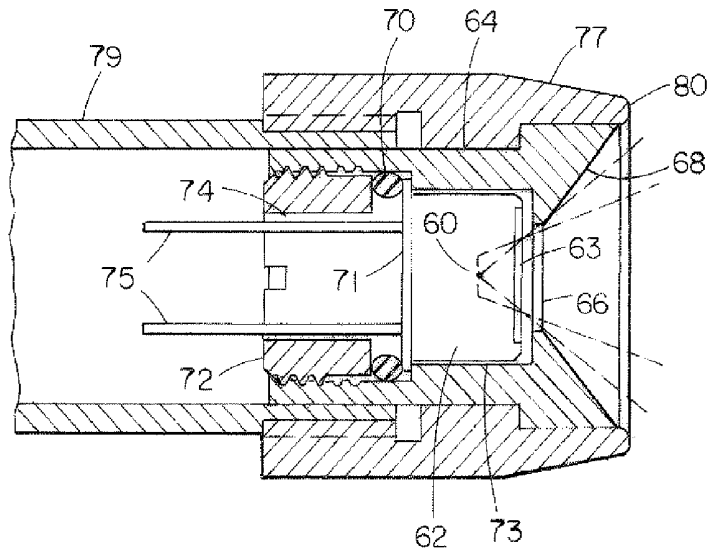

FIG. 2A

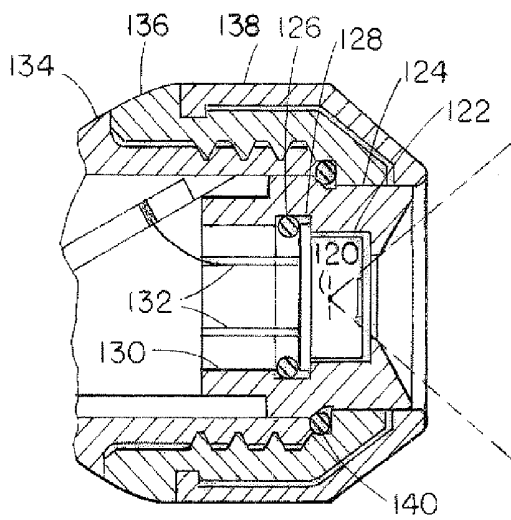

FIG. 2B

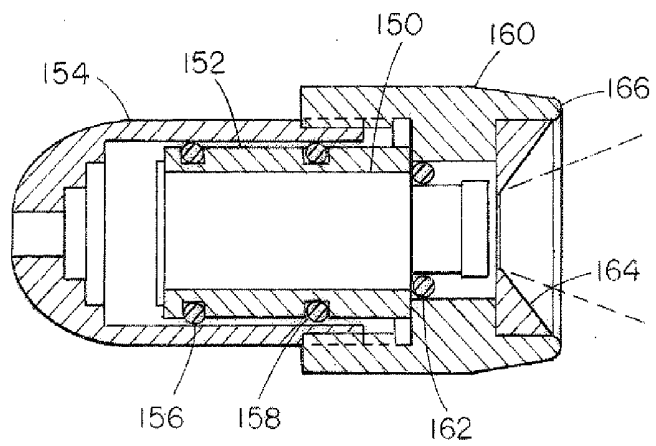

FIG. 2C

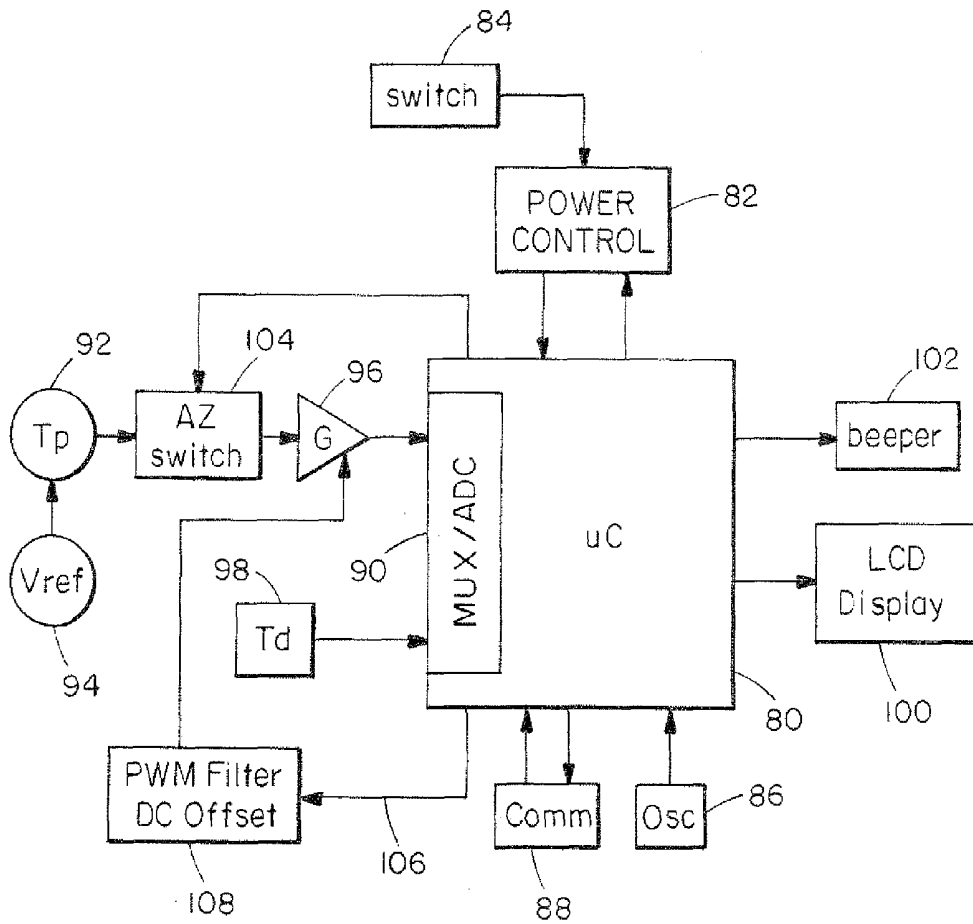

FIG. 3

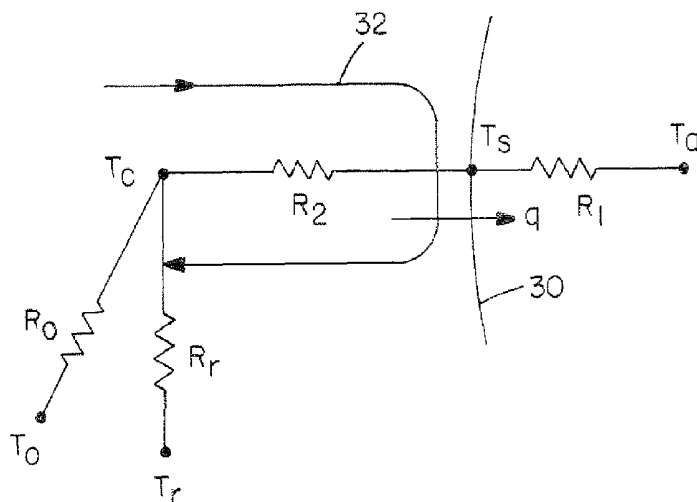

FIG. 4

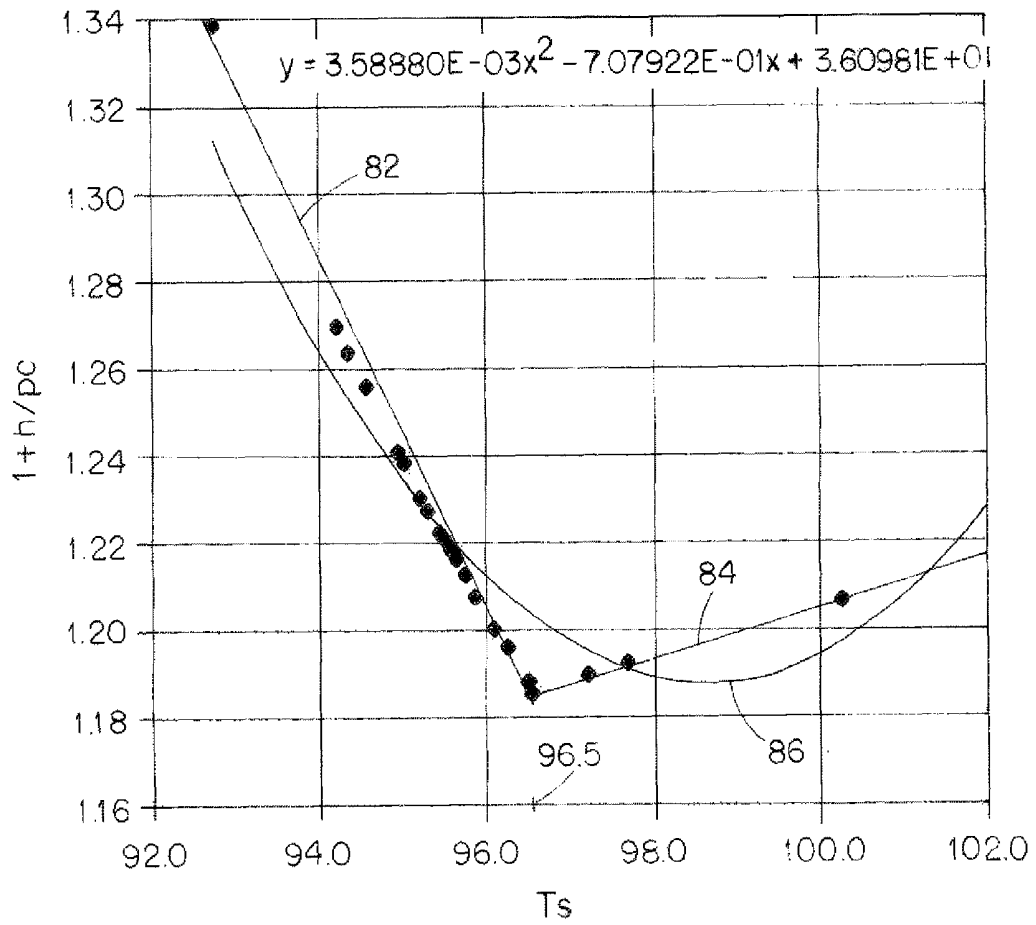

FIG. 5

TEMPORAL ARTERY TEMPERATURE DETECTOR

RELATED APPLICATIONS

This application is a continuation of U.S. application Ser. No. 12/011,467, filed Jan. 25, 2008 now U.S. Pat. No. 7,787,938, which is a continuation of application Ser. No. 10/684,818, filed Oct. 14, 2003, now U.S. Pat. No. 7,346,386, which is a continuation of application Ser. No. 09/923,240, filed Aug. 3, 2001, now abandoned, which is a continuation of application Ser. No. 09/151,482, filed Sep. 11, 1998, now U.S. Pat. No. 6,292,685.

The entire teachings of the above applications are incorporated herein by reference.

BACKGROUND OF THE INVENTION

In recent years, infrared thermometers have come into wide use for detection of temperature of adults. For core temperature readings, infrared thermometers which are adapted to be inserted into the patient's ear have been very successful. Early infrared thermometers were adapted to extend into the ear canal in order to view the tympanic membrane and provide an uncorrected, direct reading of tympanic temperature which correlates with pulmonary artery temperature. More recently, however, to provide for greater comfort and ease of use, ear thermometers have been designed to provide corrected readings of the generally cooler distal ear canal. Such thermometers measure temperature of distal ear canal tissue and calculate arterial core temperature via heat balance.

Core temperature is a term used to describe deep body temperature and is approximated by oral, rectal, ear, pulmonary artery, esophageal and bladder temperatures and the like. Of those temperatures, pulmonary artery temperature is the most precise definition of core temperature since it is closest to the heart and its blood is supplied to all tissues. Calculations of arterial core temperature via heat balance provide approximations of the pulmonary artery temperature, and unless otherwise indicated, core temperature refers to the pulmonary artery temperature.

The arterial heat balance approach is based on a model of heat flow through series thermal resistances from the arterial core temperature to the ear skin temperature and from the ear skin temperature to ambient temperature. Accordingly, after sensing both the skin temperature and ambient temperature, the arterial core temperature can be calculated. The thermal resistance model also allows for computation of equivalent oral and rectal temperatures with the mere adjustment of a weighting factor in the computation. Infrared ear thermometers using the arterial heat balance are disclosed in U.S. Pat. Nos. 4,993,419; 5,012,813; 5,199,436; 5,381,796; 5,445,158; 5,653,238 and 5,271,407, the entire teachings of which are incorporated herein by reference. To avoid clinical difficulties in using ear thermometers, particularly with neonates, axillary (underarm) infrared thermometers have been introduced. Infrared thermometers designed for axillary temperature measurements are presented in U.S. patent application Ser. Nos. 08/469,484, 08/738,300 and 08/881,891, the entire teachings of which are incorporated herein by reference. In each of those devices, an infrared detector probe extends from a temperature display housing and may easily slide into the axilla to lightly touch the apex of the axilla and provide an accurate infrared temperature reading in as little as one-half

second. The axillary thermometer also relies on the arterial heat balance approach to provide arterial, oral or rectal temperature.

The axillary infrared thermometer has found great utility not only with neonates but as a screening tool in general, and especially for small children where conventional temperature measurements such as a thermometer under the tongue or a rectal thermometer are difficult.

In ear and neonate axillary thermometry, the difference between skin temperature and ambient temperature has been weighted by a coefficient approximating h/pc , where h is an empirically determined coefficient which includes a radiation view factor between the skin tissue and ambient, p is perfusion rate and c is blood specific heat. In ear and neonate axillary thermometry, that coefficient was found empirically to be about 0.09 and 0.05, respectively, with only minor variations. However, with greater exposure for heat transfer and higher vasomotor functions, that coefficient has been determined empirically for the adult axillary region to be about 0.13 with much more significant variations according to the patient's temperature.

SUMMARY OF THE INVENTION

The present invention provides for particularly convenient temperature readings of neonate, child and adult temperatures by detecting the temperature of the forehead directly over the superficial temporal artery.

Because arteries receive blood directly from the heart, they are a good choice for detecting core temperature, but an artery at the extremities of the body, such as those felt as pulse points at the wrist or ankle, are highly subject to vasoconstriction. This means, for example, that when an individual is extremely sick, in shock, or even just cold or nervous, the arteries constrict to reduce the flow of blood to that area as a means of retaining heat, or as in the case of shock, in an effort to redirect the blood to more critical areas of the body. This can result in a large temperature change at the artery which is a local artifact only and not representative of core temperature.

Ruling out those arteries located in the extremities, in attempting to replicate the temperature at the source (the heart), we find, in the temporal artery, an artery as short a distance from the heart as possible, with a high and relatively constant blood flow, and that is readily accessible on all individuals. The heart, the lungs and the brain are vital to our very existence, so the supply of blood is high to these organs and continues as high as possible even through, in the face of grave illness, other areas may shut down to accommodate.

Originating in the heart is the aorta, the main trunk of the arterial system. A direct extension of the aorta is the common carotid artery, a robust artery which runs upward in the neck and divides into the internal and external carotids. But, the carotids, even the external carotid, are at best partially embedded, and at worst completely embedded in the skull, and therefore are not accessible at the skin. Extending directly from the carotid is the temporal artery, again an artery dividing internally and externally. We look to the external branch which travels in front of the ear and up into the soft temple area, terminating in a fork directly between the skin and the skull adjoining the eyebrow.

Demonstrably, the temporal artery is very easily accessible; in fact in most individuals, it is usually quite visible. Terminating in a two-prong fork, it easily doubles the assurance of measuring the correct area. Touching it does not present a risk of injury. There are no mucous membranes present, thus eliminating the risk of contaminates such as

those found in the mouth and rectum. And, despite lying so close to the skin surface, the temporal artery perfusion, which is the flow of blood per unit volume of tissue, remains relatively constant and so ensures the stability of blood flow required for our measurement.

In accordance with one aspect of the invention, a temperature sensor is scanned across the forehead, preferably in the vicinity of the temporal artery, and a peak temperature reading is provided from the scan. At least three readings per second should be made during the scan, preferably about ten readings per second. The method can be extended to other arteries near the skin such as in the axilla. The preferred radiation sensor is a radiation sensor which views a target surface of the forehead through a reflective cup. The cup has a large open diameter close to the target surface and a window at the base of the cup through which the radiation sensor views the target, the cup being out of the field of view of the sensor. The reflective cup is spaced from the target surface by a smooth lip of low thermal conductivity material.

As in prior ear and axillary thermometers, internal core temperature can be computed from the function

$$T_c = (1 + (h/pc))(T_s - T_a) + T_a \quad (1)$$

where T_s and T_a are the skin and ambient temperatures. The function can be seen to include a weighted difference of surface temperature and ambient temperature with a weighting coefficient h/pc .

In accordance with another aspect of the invention, electronics in the detector compute an internal temperature of the body as a function of ambient temperature and sensed surface temperature. The function includes a weighted difference of surface temperature and ambient temperature, the weighting being varied with target temperature. The weighting varies with target temperature through a minimum in the range of 96° F. to 100° F., the weighting increasing above and below the minimum. In particular, the weighting is an approximation of h/pc at the forehead artery where h is a heat transfer coefficient between the target surface and ambient, p is perfusion rate and c is blood specific heat. In a preferred embodiment, the weighting is a linear approximation having a minimum between 96° F. and 97° F. The approximation of h/pc at the minimum is about 0.19. In another embodiment, the weighting includes a polynomial approximation of $1 + h/pc = k_1 T_s^2 - k_2 T_s + k_3$ where h is a heat transfer coefficient between the target surface and ambient, p is perfusion rate, c is blood specific heat T_s is skin temperature, k_1 is approximately 0.00359, k_2 is approximately 0.708 and k_3 is approximately 36.1.

BRIEF DESCRIPTION OF THE DRAWINGS

The foregoing will be apparent from the following more particular description of example embodiments of the invention, as illustrated in the accompanying drawings in which like reference characters refer to the same parts throughout the different views. The drawings are not necessarily to scale, emphasis instead being placed upon illustrating embodiments of the present invention.

FIG. 1 illustrates an infrared thermometer scanning the temporal artery in the forehead in accordance with the present invention.

FIGS. 2A, B and C are cross-sectional views of three embodiments of the radiation sensor assembly of the invention.

FIG. 3 is an electrical block diagram of the electronics of the thermometer of FIG. 1.

FIG. 4 illustrates the arterial heat balance model.

FIG. 5 illustrates the change in weighting coefficient ($1 + h/pc$) with change in skin temperature.

DETAILED DESCRIPTION OF THE INVENTION

A description of preferred embodiments of the invention follows.

As illustrated in FIG. 1, the temporal arteries 12 and 14 extend upwardly toward the side of the human face and bifurcate at 16 and 18 in the forehead region. In that region, the temporal artery passes over the skull bone very close to the skin and is thus termed the superficial temporal artery. The superficial temporal artery is, therefore, particularly accessible for providing temperature readings and, as an artery, has a temperature close to the heart temperature. Further, there are no known arterial/venous anastomoses, that is, shunts between the artery and veins for regulation of skin temperature. Accordingly, the blood flow is relatively stable, varying a maximum of only 50% as opposed to as much as 500% in other areas of the skin.

To locate the temporal artery, a temperature detector, preferably a radiation detector 20, is scanned across the side of the forehead over the temporal artery while electronics in the detector search for the peak reading which indicates the temporal artery. Preferably, that temperature reading is then further processed in accordance with an algorithm specific to the temporal artery for providing a display temperature which may, for example, correspond to core, oral or rectal temperature.

The temperature detector 20 provides an audible beep with each peak reading. A display 26 provides the temperature reading resulting from the electronic processing discussed below, updated to each new peak reading. A button 28 enables the user to activate the temperature detector. In one embodiment, an LED 22 which flashes with each peak reading can be observed when someone other than the patient performs the reading, and another LED on the other side of the housing can be observed by the patient, particularly when taking his own temperature.

FIG. 2A illustrates one sensor assembly for the radiation detector of FIG. 1. The assembly is similar to that presented in application Ser. No. 08/881,891. A thermopile radiation sensor 60 is mounted within a can 62 in conventional fashion. For high stability the thermopile may be a vapor deposited thermopile surrounded with xenon gas, but for reduced cost it may be a semiconductor thermopile surrounded with air. An infrared radiation transparent window 63 is provided over a viewing opening in the can. The can 62 is set within a bore within a heat sink 64. A shoulder defines an aperture 66 at the base of a conical emissivity compensating cup 68 through which the thermopile views the target. The cup is preferably of low emissivity in order to provide emissivity compensation as disclosed in U.S. Pat. No. 4,636,091. Preferably, the heat sink 64 in which the cup is formed is of aluminum. Alternatively, the heat sink may be of brass, nickel plated in the cup region.

An elastomeric o-ring 70 is positioned behind the can 62. A plug 72 is threaded into the bore in the heat sink 64 to press the ring 70 against the rear flange 71 of the can and thus press the flange against a shoulder in the heat sink bore. With the flange pressed against the shoulder and having a close tolerance with the larger diameter of the bore, an air gap 73 is maintained about the side and front of the can. This arrangement provides for good thermal contact between the can and the heat sink 64 at the rear and also makes the thermopile highly resistant to mechanical shock since the shock is only transferred through the thin flange past the shock absorbing elastomer. If the

flange were rigidly clamped between metal parts, there would be a danger of shock breaking the gas seal of the can. An opening 74 is provided through the center of the plug 72 for access of electrical leads 75 to the thermopile can. The heat sink 64 is press fit in a plastic cap 77 which is threaded on to the tubular head 79 of the detector.

The plastic cap 77 in which the sensor assembly is mounted is of low thermal conductivity, preferably less than one hundredth that of aluminum. The housing thermally isolates the heat sink 64 from the surrounding environment to minimize heat flow to the heat sink. Further, the heat sink 64 is of significant thermal mass. Accordingly, the RC time constant for change in temperature of the radiation sensor, with change in temperature to which the housing is exposed, can be made large for a more stable temperature reading. The thermal resistance is made high by the low conductivity housing, and the thermal capacitance is made high by the large mass of the heat sink 64. That RC time constant should be at least 5 minutes and is preferably about 25 minutes.

Past designs of infrared thermometers, such as presented in U.S. Pat. No. 4,993,419, have relied on a massive thermopile can which also served as the heat sink. That design assured a high RC time constant for thermal conduction through the external thermal barrier to the heat sink relative to a thermal RC time constant for temperature response of the cold junction to heat transferred to the heat sink. The latter low RC time constant was obtained by assuring a low thermal resistance to the cold junction using expensive high conductivity material in a specially designed can/heat sink. In the present device, a design goal is to use a conventional low cost thermopile mounted in a light weight can which does not provide the low thermal resistance of the prior design. Accordingly, it is important that the can be mounted to assure that all heat conduction to the thermopile be through the rear of the can which serves as the thermal ground to the thermopile. That objective is obtained by making thermal contact to the can through the rear flange and assuring an air space about the sides and front of the can.

Forming the emissivity compensating cup 68 in the heat sink reduces the cost of the assembly and also improves the thermal characteristics. Although the emissivity of the cup is ideally zero, it is in fact about 0.1. With the cup formed as part of the heat sink, it is at the temperature to which the can is grounded. Accordingly, any thermal emissions from the surface of cup 68 will be at substantially the same temperature as the cold junction and thus not be seen. The electronics can also be calibrated to compensate for the loss of reflectance due to non-ideal emissivity, but that calibration is affected by the temperature of the reflective surface. By assuring that the surface of cup 68 is at the temperature to which the thermopile can is grounded, the temperature of the surface is generally known and compensation can be made temperature dependent.

When adapted to household use, concerns for patient cross-contamination associated with clinical temperature detectors is not so significant. Further, at the forehead, evaporation of moisture is not as significant as in the ear and axillary applications. Accordingly, the disposable radiation transparent covers used in prior infrared thermometers, such as in Ser. No. 08/469,484 and 08/738,300 is less desirable. However, in the clinical environment, the transparent cover is still preferred to prevent cross contamination.

During the scanning of the radiation detector across the forehead, contact of the housing 78 with the skin can cause cooling of the skin. To minimize that cooling, a circular lip 80 protrudes axially beyond the tip of the heat sink 64. The lip has a thin radius of 0.02 to 0.05 inch, preferably about 0.03

inch, to minimize the thermal conductance through the insulation material. The heat sink 64 is recessed 0.02 to 0.05 inch, preferably about 0.03 inch, behind the tip of the lip. For comfort during scanning, the lip has a smooth curve.

Another embodiment of the radiation sensor assembly is presented in FIG. 2B. As in the prior embodiment, the thermopile 120 is positioned within a can 122. The can is retained in a heat sink 124 by an o-ring 126 which presses against the flange 128 of the can and is set within a circumferential groove in the bore 130 of the heat sink. As before, wires 132 extend through that bore. The housing 134 of the detector head is a split tube formed of two parts which meet along longitudinal seams. The two tube parts are held together by a nut 136 to which a plastic cap 138 is snap fit. The heat sink is retained in the assembly by an o-ring 140 which is seated within a groove in the heat sink and a groove in the nut 136. As before, the cap 138 has a curved lip which extends beyond the tip of the heat sink 124. Cap 138 is of soft material for the comfort of the patient.

In the embodiment of FIG. 2C, the thermopile is positioned within a can 150 of high thermal mass similar to that disclosed in U.S. Pat. No. 5,012,813. The can is set within a sleeve 152 which is retained in the head housing 154 by o-rings 156 and 158. A plastic cap 160 is threaded onto the head 154, and the can 150 is centered within the cap by an additional o-ring 162. A low emissivity cup 164 is press fit within the cap 160 and, as before, is recessed behind a smooth lip 166.

An electrical block diagram for the radiation detector is presented in FIG. 3. A microprocessor 80 is at the heart of the circuit. A power control circuit 82 responds to activation of the button switch 84 by the user to apply power to the microprocessor and other elements of the circuit. That power is maintained until the microprocessor completes the measurement cycle and signals the power control 82 to power down. The microprocessor is clocked by an oscillator circuit 86 and may communicate with an external source for programming and calibration through communication conductors 88. The temperature determined by the microprocessor is displayed on the liquid crystal display 100, and detection of peaks during the temperature processing is indicated by a beeper 102. Peaks are detected from readings taken at least three times per second, and preferably about ten times per second, for rapid scan across the forehead to avoid cooling of the forehead through the detector. During the measurement process, the microprocessor takes readings through a multiplexer/analog-to-digital converter 90. The preferred microprocessor 80 is a PIC16C74 which includes an internal 8-bit A-D converter. To minimize expense, the circuit is designed to rely solely on that A-D converter.

Thermopile 92 provides a voltage output signal equal to the fourth power difference between target temperature and the temperature of the thermopile cold junction, offset by voltage reference 94. The voltage output from the thermopile is amplified by an amplifier 96, having a gain in the order of 1000, which also provides an offset determined by a pulse width modulated filter 108 controlled by the microprocessor. Through operation of the multiplexer, the microprocessor provides an analog-to-digital conversion of the amplified sensor output and of the detector temperature T_d provided by temperature sensor 98. The temperature sensor 98 is positioned to sense the substantially uniform temperature of the thermopile cold junction, can and heat sink. An auto zero switch 104 is included to allow for isolation of the amplifier 96 from the thermopile 92 during a calibration sequence as discussed in prior U.S. application Ser. No. 08/738,300.

It is well known that the output of the thermopile is proportional to $(T_s^4 - T_d^4)$ where T_s is the target skin temperature

viewed by the radiation detector and T_d is the temperature of the detector measured by sensor **98**. From that relationship, T_s can be computed. It is also known that, based on the determined skin temperature and the ambient temperature to which the skin is exposed, an internal core temperature can be computed using the arterial heat balance approach illustrated in FIG. 4. Heat flux q from the internal core temperature T_c passes through the skin **30** to the ambient environment at temperature T_a . The skin is thus held at some intermediate temperature T_s .

The heat loss of skin, such as at the forehead, the external ear canal or axilla, to the environment can be calculated with the following well-known equation:

$$q = hA(T_s - T_a) \tag{2}$$

where q is heat flow, A is surface area, T_s and T_a the skin and ambient temperatures, respectively, and h is an empirically determined coefficient which includes a radiation view factor between the skin tissue and ambient. The equation takes the linear form for simplicity. Although the exact form of the equation is fourth-power due to the radiation exchange, the linearized form provides excellent accuracy over the range of interest of about 900 to 105° F.

Heat flow from the core arterial source to the skin is via blood circulation **32**, which is many times more effective than tissue conduction. Thermal transport via the circulation can be described with the following equation:

$$q = wc(T_c - T_s) \tag{3}$$

where q again is heat flow, w is blood mass flow rate, c is blood specific heat, and T_c and T_s are core and skin temperatures, respectively.

Accordingly, the skin can be viewed thermally as tissue being warmed by its blood supply as governed by equation 3, balanced by radiating heat to ambient as governed by equation 2.

Equating:

$$hA(T_s - T_a) = wc(T_c - T_s) \tag{4}$$

Simplifying by dividing by surface area A :

$$h(T_s - T_a) = pc(T_c - T_s) \tag{5}$$

where p is blood flow per unit area, also termed perfusion rate.

Equation 5 then provides a method to calculate core temperature T_c when skin temperature T_s and ambient temperature T_a are known, and the coefficients (or their ratio) have been empirically determined.

Solving for T_c :

$$T_c = (h/pc)(T_s - T_a) + T_s \tag{6}$$

where h/pc , the weighting coefficient which weights the difference of surface temperature and ambient temperature, is empirically determined on a statistical basis over a range of patients and clinical situations.

An alternative method of calculating is to employ an electrical analog technique, since equations 2 and 3 have the identical form of a simple voltage/current relationship. The method employs the convention that electrical current is analogous to heat flow and voltage differential is analogous to temperature differential.

Accordingly, equations 2 and 3 may be written as:

$$q = (1/R_1)(T_s - T_a) \tag{7}$$

$$q = (1/R_2)(T_c - T_s) \tag{8}$$

and the electrical circuit can be drawn, with resistances R_1 and R_2 and with T_c and T_a as constant temperature (voltage) reservoirs (FIG. 4). A third equation with a more convenient form can be written as:

$$q = (1/(R_1 + R_2))(T_c - T_a) \tag{9}$$

Using equations 7 and 9 and solving for T_c :

$$T_c = ((R_1 + R_2)/R_1)(T_s - T_a) + T_a \tag{10}$$

and finally:

$$T_c = k(T_s - T_a) + T_a \tag{11}$$

which is the precise form of the heat balance equation programmed into arterial heat balance instruments, with $(R_1 + R_2)/R_1$ expressed as the k -Factor.

The k Factor can be rewritten as follows:

$$K = \frac{R_1 + R_2}{R_1} = 1 + \frac{R_2}{R_1} = 1 + (h/pc) \tag{12}$$

Accordingly, in either form, equation 6 or 11, it can be seen that the weighting coefficient h/pc is applied to the difference of surface and ambient temperature.

In the weighting coefficient, c is a constant. In ear temperature and neonatal axillary temperature measurements, the perfusion rate is also generally constant, resulting in h/pc of about 0.09 for adult ears and 0.05 for neonates. For a normal adult, the perfusion rate of the axilla is such that the weighting coefficient h/pc is about 0.13. Further, the perfusion rate varies according to the condition of the patient. In particular, with a fever, the perfusion rate can become much higher. Similarly, in the forehead, perfusion rate varies with skin temperature.

In both the ear and axilla, the coefficient h is relatively constant. The forehead has greater exposure to the ambient environment, and the radiation heat loss increases with increased skin temperature. Thus, where the weighting coefficient h/pc decreased for all increasing skin temperatures in the ear and axilla temperature measurements, it has been found that, as illustrated in FIG. 5, the weighting coefficient reaches a minimum at near normal body temperature and then, due to the increasing value of h , increases. Empirical data suggests that the value h/pc decreases linearly **82** to a value of about 0.19 and a temperature of about 96-97° F. The coefficient then increases linearly with skin temperature but at a lesser slope at **84**. The linear approximations illustrated in FIG. 5 are used in the computations in the clinical model. However, in the consumer model, those linear approximations are replaced by a single polynomial approximation **86**:

$$1 + h/pc = 0.0035888T_s^2 - 0.707922T_s + 36.0981$$

Since all body site temperatures of interest arise from the arterial temperature source, the arterial heat balance can be applied to any site. Accordingly, based on the Thevenin equivalents theorem, oral and rectal diagnostic equivalents T_o and T_r of arterial temperature can be calculated by appropriate selection of k -Factor, empirically taking into consideration resistances R_o and R_r .

Individual aspects of the radiation detector which make it particularly suited to providing temperature readings from the temporal artery and other arteries can be found in applicant's prior designs. However, none of those designs provide the unique combination of elements which enable consistent measurements of core temperature by scanning across a superficial artery. Specifically, the Exergen D501 Industrial Temperature Detector used in emissivity compensating cup

and provided a peak temperature based on about ten temperature readings per second. However, that device did not perform a heat balance computation and was thus not suited to measurement of core temperature. The emissivity compensating cup was utilized in the axillary temperature detector with a heat balance computation, but that unit was not adapted to be scanned across the target surface. The detected peak in that device used to indicate when the reading had stabilized and could be relied upon. That peak detection was based on only one reading per second. Applicant's prior ear temperature detectors have obtained a peak temperature from ten readings per second but with pivoting of the detector rather than with lateral scan across the target surface. There was no emissivity compensating cup.

While this invention has been particularly shown and described with references to preferred embodiments thereof, it will be understood by those skilled in the art that various changes in form and details may be made therein without departing from the spirit and scope of the invention as defined by the appended claims.

What is claimed is:

1. A method of providing an internal body temperature approximation of a human body, the method comprising: measuring infrared radiation by scanning a thermopile radiation detector across a target surface of a forehead, wherein the target surface of the forehead is skin surface over the superficial temporal artery passing over the skull bone directly between the skin and the skull very close to the skin, the radiation detector providing an electrical output; determining a sensed skin surface temperature from the radiation; sensing ambient temperature to which the body is exposed; and in electronic circuitry, using the measured infrared radiation and the sensed ambient temperature to which the body is exposed, determining the internal body temperature approximation, the determined internal body temperature approximation comprising the sensed skin surface temperature plus an amount based on the sensed skin surface temperature and the sensed ambient temperature to which the body is exposed.
2. A method according to claim 1, wherein the step of determining an internal body temperature approximation comprises determining an approximation of oral temperature.
3. A method according to claim 1, wherein the step of determining an internal body temperature approximation comprises determining an approximation of rectal temperature.

4. A method according to claim 1, wherein the step of determining an internal body temperature approximation comprises determining an approximation of core temperature.
5. A method according to claim 1, further comprising: displaying the internal body temperature approximation.
6. A method of providing an internal body temperature approximation of a human body, the method comprising: measuring infrared radiation by scanning a thermopile radiation detector across a target surface of a forehead, wherein the target surface of the forehead is skin surface over the superficial temporal artery passing over the skull bone directly between the skin and the skull very close to the skin, the radiation detector providing an electrical output; sensing ambient temperature to which the body is exposed; and in electronic circuitry, determining the internal body temperature approximation by processing the measured infrared radiation and the sensed ambient temperature to which the body is exposed.
7. A method according to claim 6, wherein the step of determining an internal body temperature approximation comprises determining an approximation of oral temperature.
8. A method according to claim 6, wherein the step of determining an internal body temperature approximation comprises determining an approximation of rectal temperature.
9. A method according to claim 6, wherein the step of determining an internal body temperature approximation comprises determining an approximation of core temperature.
10. A method according to claim 6, further comprising: displaying the internal body temperature approximation.
11. A method according to claim 6, further comprising providing as the measured radiation a peak radiation detector reading from plural readings during the step of scanning.
12. A method according to claim 1, further comprising providing as the measured radiation a peak radiation detector reading from plural readings during the step of scanning.
13. A method according to claim 6, wherein the determined internal body temperature approximation comprises temperature of the skin surface plus an amount based on the skin surface temperature and the sensed ambient temperature to which the body is exposed.

* * * * *

专利名称(译)	颞动脉温度探测器		
公开(公告)号	US9194749	公开(公告)日	2015-11-24
申请号	US12/857252	申请日	2010-08-16
[标]申请(专利权)人(译)	POMPEI FRANCESCO		
申请(专利权)人(译)	POMPEI FRANCESCO		
当前申请(专利权)人(译)	的Exergen CORPORATION		
[标]发明人	POMPEI FRANCESCO		
发明人	POMPEI, FRANCESCO		
IPC分类号	A61B6/00 G01K1/00 A61B5/00 G01K13/12 G01J5/16 G01J5/06 G01J5/02 G01J5/00 A61B5/01 G01J5/04 G01J5/10 G01K13/00		
CPC分类号	G01J5/04 A61B5/015 G01J5/0022 G01J5/0025 G01J5/02 G01J5/026 G01J5/06 G01J5/16 A61B5/01 A61B5/742		
其他公开文献	US20110092822A1		
外部链接	USPTO		

摘要(译)

通过在颞动脉上方的前额侧扫描热辐射传感器来获得体温测量值。处理峰值温度测量以计算作为环境温度和感测的表面温度的函数的身体的内部温度。该功能包括表面温度和环境温度的加权差，加权随目标温度变化，最小值在96°F和100°F之间。辐射传感器通过发射率补偿杯观察目标表面。通过低导热率的圆形唇缘与皮肤隔开。

