



(19) **United States**

(12) **Patent Application Publication**
Banet et al.

(10) **Pub. No.: US 2007/0276262 A1**
(43) **Pub. Date: Nov. 29, 2007**

(54) **BILATERAL DEVICE, SYSTEM AND METHOD FOR MONITORING VITAL SIGNS**

Publication Classification

(75) Inventors: **Matthew John Banet**, Del Mar, CA (US); **Michael James Thompson**, San Diego, CA (US); **Zhou Zhou**, La Jolla, CA (US); **Henk Visser**, San Diego, CA (US)

(51) **Int. Cl.**
A61B 5/02 (2006.01)
A61B 5/00 (2006.01)

(52) **U.S. Cl.** **600/485; 600/323**

(57) **ABSTRACT**

The invention features a monitoring device that measures a patient's vital signs (e.g. blood pressure). The device features a first sensor configured to attach to a first portion of the patient's body that includes: i) a first electrode configured to generate a first electrical signal from the first portion of the patient's body; ii) a first light-emitting component; and iii) a first photodetector configured to receive radiation from the first portion of the patient's body after the radiation is emitted by the first light-emitting component and in response generate a first optical waveform. The device also features a second sensor that includes essentially the same components. An amplifier system, in electrical contact with the first and second electrodes, receives first and second electrical signals from the two sensors to generate an electrical waveform. A processor, in electrical contact with the amplifier system, receives the electrical waveform, the first optical waveform, and the second optical waveform. The processor runs computer code that processes the input waveforms with an algorithm to determine at least one of the patient's vital signs.

Correspondence Address:

Triage Wireless, Inc.
Matthew John Banet
6540 LUSK BLVD., C200
SAN DIEGO, CA 92121

(73) Assignee: **TRIAGE WIRELESS, INC.**, San Diego, CA (US)

(21) Appl. No.: **11/420,744**

(22) Filed: **May 27, 2006**

Related U.S. Application Data

(63) Continuation of application No. 11/420,281, filed on May 25, 2006.

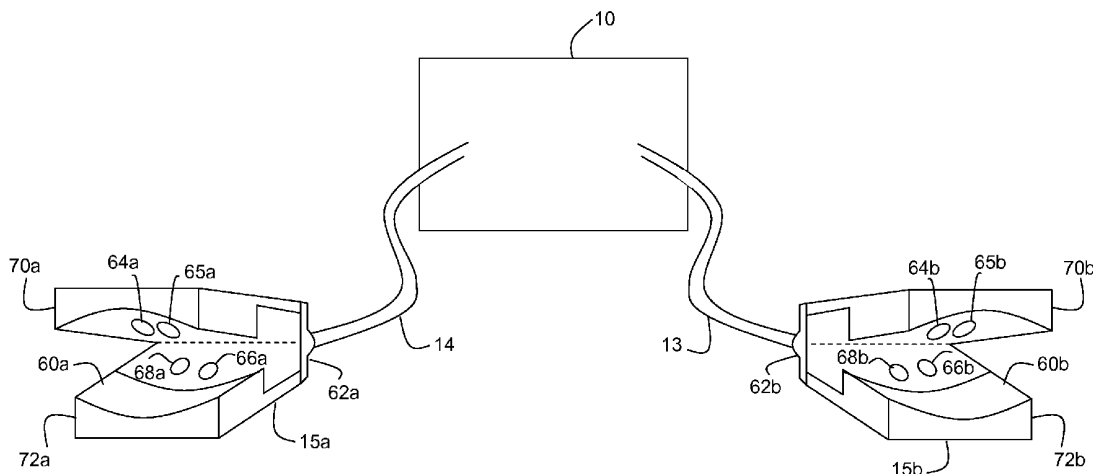

ONE-TIME MODE

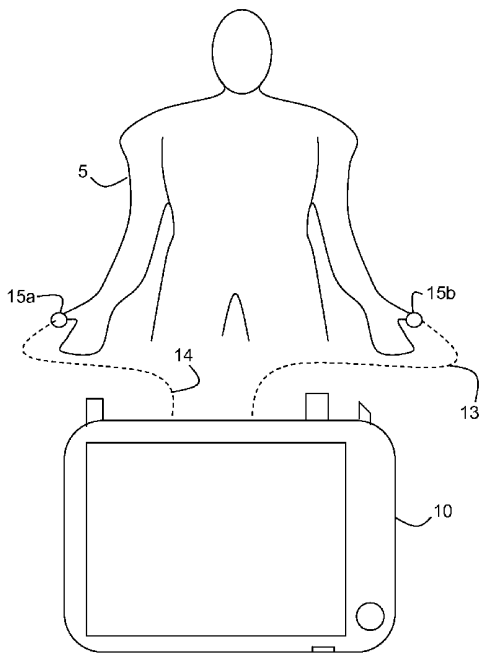

Fig. 1A

CONTINUOUS MODE

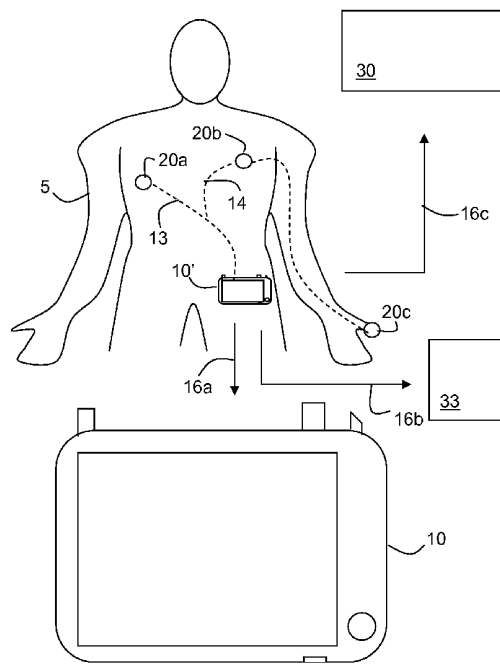

Fig. 1B

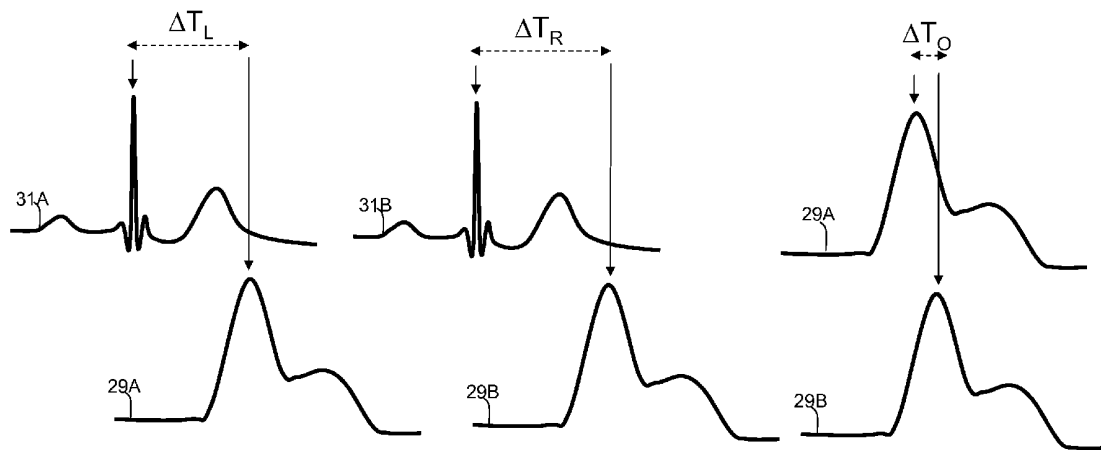

Fig. 2A

Fig. 2B

Fig. 2C

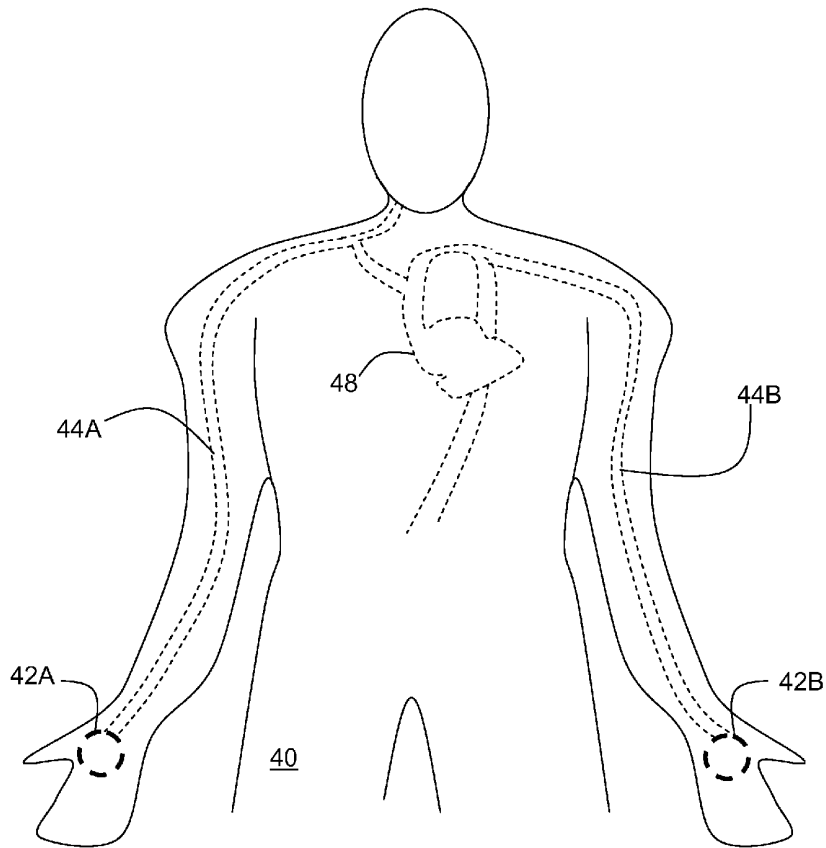

Fig. 3

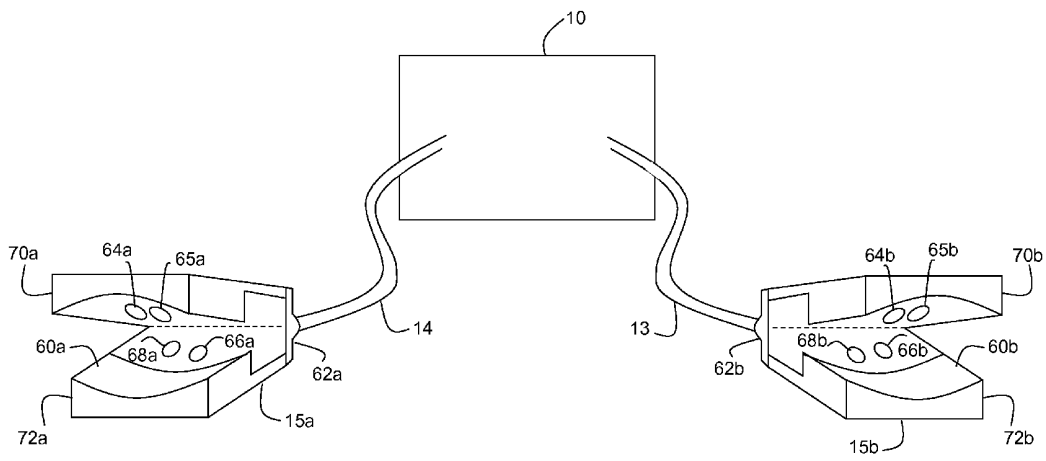
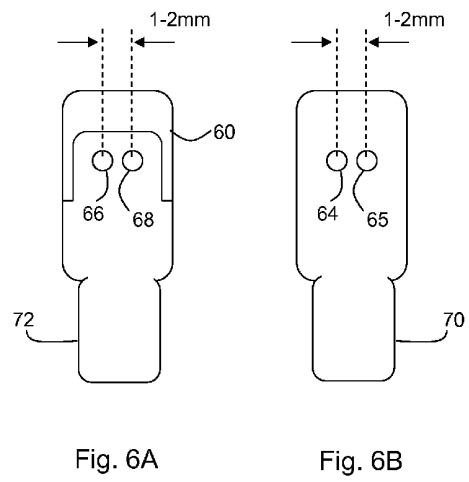
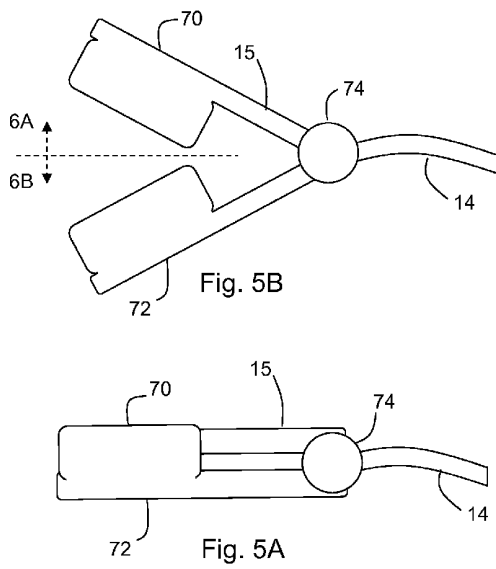

Fig. 4



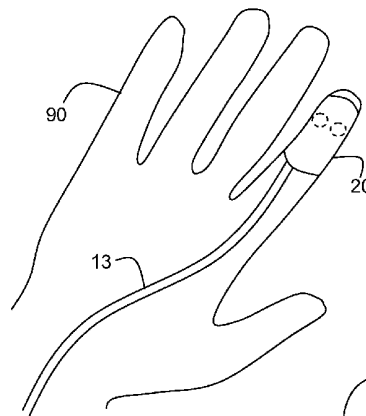
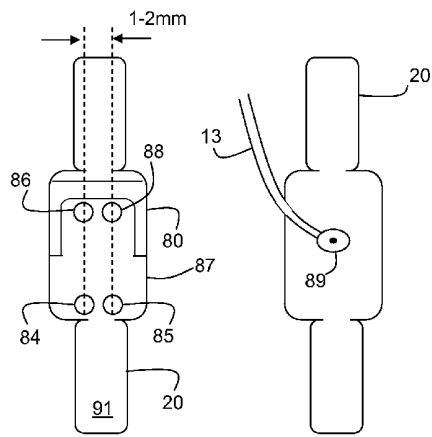

Fig. 8

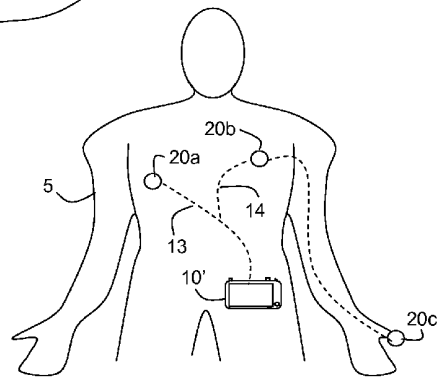

Fig. 9

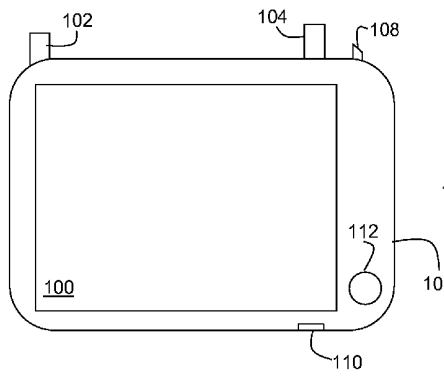

Fig. 10A

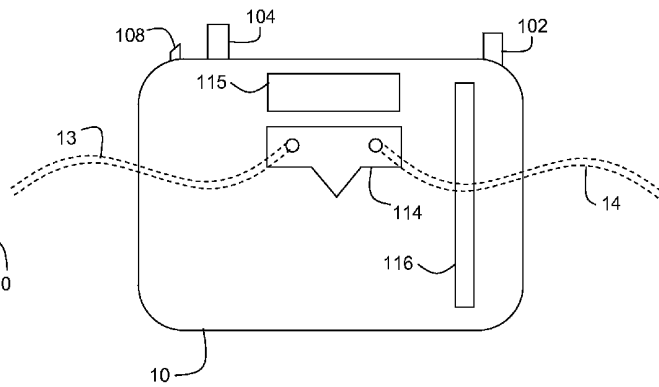

Fig. 10B

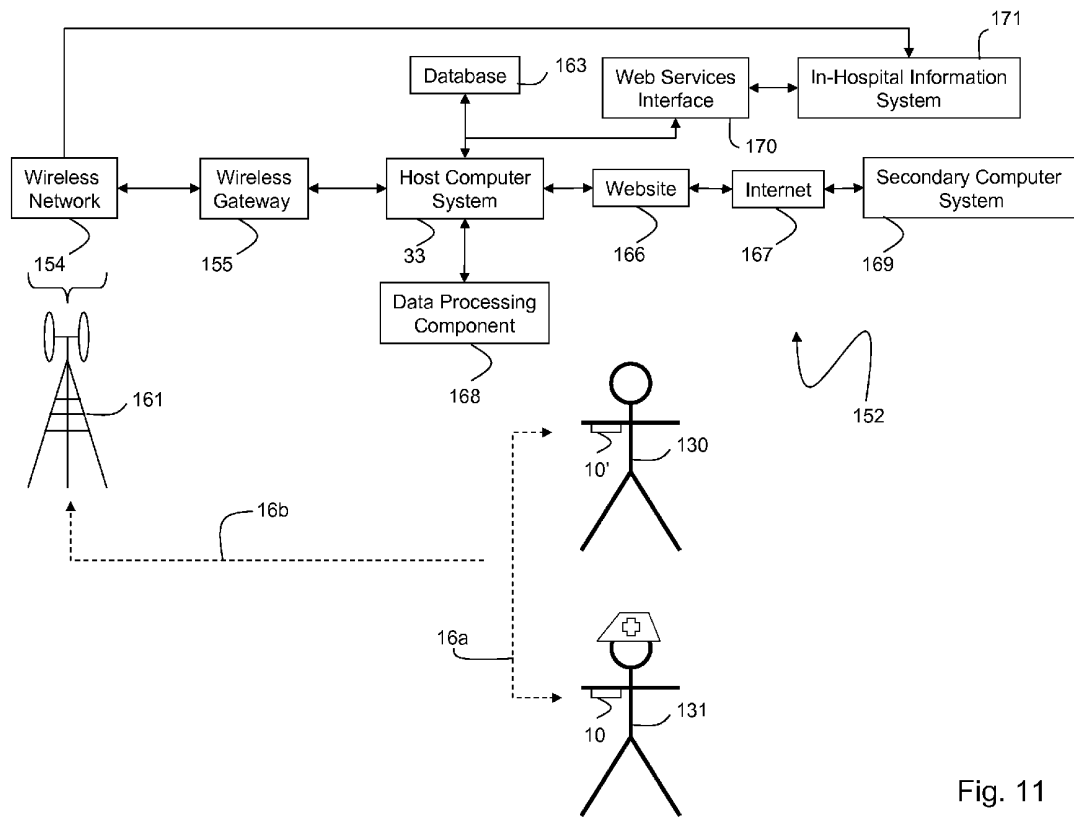

Fig. 11

BILATERAL DEVICE, SYSTEM AND METHOD FOR MONITORING VITAL SIGNS

CROSS REFERENCES TO RELATED APPLICATION

[0001] This Application is a Continuation of U.S. Ser. No. 11/420,281, filed May 25, 2006.

STATEMENT REGARDING FEDERALLY SPONSORED RESEARCH OR DEVELOPMENT

[0002] Not Applicable

BACKGROUND OF THE INVENTION

[0003] 1. Field of the Invention

[0004] The present invention relates to a method and system for measuring vital signs, and particularly blood pressure, from a patient.

[0005] 2. Description of the Related Art

[0006] Pulse oximeters are medical devices featuring an optical module, typically worn on a patient's finger or ear lobe, and a processing module that analyzes data generated by the optical module. The optical module typically includes first and second light sources (e.g., light-emitting diodes, or LEDs) that transmit optical radiation at, respectively, red ($\lambda \sim 600\text{-}700$ nm) and infrared ($\lambda \sim 800\text{-}1200$ nm) wavelengths. The optical module also features a photodetector that detects transmitted radiation that passes through an underlying artery within, e.g., the patient's finger or earlobe. Typically the red and infrared LEDs sequentially emit radiation that is partially absorbed by blood flowing in the artery. The photodetector is synchronized with the LEDs to detect the transmitted radiation. In response, the photodetector generates a separate radiation-induced signal corresponding to each wavelength. The signal, called a plethysmograph, varies in a time-dependent manner as each heartbeat varies the volume of arterial blood and hence the amount of radiation absorbed along the path of light between the LEDs and the photodetector. A microprocessor in the pulse oximeter digitizes and processes plethysmographs generated by the red and infrared radiation to determine the degree of oxygen saturation in the patient's blood using algorithms known in the art. A number between 94%-100% is considered normal, while a number below 85% typically indicates the patient requires hospitalization. In addition, the microprocessor analyzes time-dependent features in the plethysmograph to determine the patient's heart rate.

[0007] Another medical device called an electrocardiograph features conductive electrodes, placed at various locations on a patient's body, that measure electrical signals which pass into an amplification circuit. The circuit generates a waveform called an electrocardiogram, or ECG, that describes a time-dependent response of the patient's cardiovascular system.

[0008] Various methods have been disclosed for using both plethysmographs and ECGs, taken alone or in combination, to measure arterial blood pressure. One such method is disclosed in U.S. Pat. No. 5,140,990 to Jones et al. The '990 Patent discloses using a pulse oximeter with a calibrated auxiliary blood pressure measurement to generate a constant that is specific to a patient's blood pressure.

[0009] Another method for using a pulse oximeter to measure blood pressure is disclosed in U.S. Pat. No. 6,616,613 to Goodman. The '613 Patent discloses processing a

pulse oximetry signal in combination with information from a calibrating device to determine a patient's blood pressure.

[0010] U.S. Pat. Nos. 5,857,795 and 5,865,755 to Golub each discloses a method and device for measuring blood pressure that processes a time difference between points on an optical plethysmograph and an ECG along with a calibration signal.

[0011] U.S. Pat. No. 6,511,436 to Asmar discloses a device for evaluating arterial wall stiffness by using pulse wave velocity measurements. The device estimates blood pressure using pulse wave velocity and a patient's biometric parameters.

[0012] Chen et al, U.S. Pat. No. 6,599,251, discloses a system and method for monitoring blood pressure by detecting plethysmographs at two different locations on a subject's body, preferably on the subject's finger and earlobe. The plethysmographs are detected using conventional pulse oximetry devices and then processed to determine blood pressure.

[0013] Inukai et al., U.S. Pat. No. 5,921,936, discloses a system that uses an electrocardiogram to detect the start of a heart beat and uses a cuff equipped with a pressure sensor to detect pulse waves in order to calculate a pulse transit time.

[0014] Suda et al., U.S. Pat. No. 5,788,634, describes a multi-purpose, clip-on sensor featuring a 'gripper' that includes an electrode pair and an optical system operating in a transmission mode. The electrode pair and optical system generate information that is processed outside of the sensor to make a blood pressure measurement.

[0015] Baruch et al., U.S. Pat. No. 6,723,054, describes an arm-worn system featuring two optical systems that measure two independent signals from a patient's arm. A processor calculates mathematical derivatives of the signals to derive a pulse transit time which can be used to calculate blood pressure.

[0016] Suga et al., U.S. Pat. No. 5,316,008, describes a wrist watch that features both optical and electrical sensors for measuring signals from a patient. During operation, the patient wears the wrist watch on one wrist, and places fingers from an opposing hand on the optical and electrical sensors. A pulse transit time is extracted from the signals and then used to calculate a blood pressure.

SUMMARY OF THE INVENTION

[0017] In one aspect, the invention features a monitoring device that measures a patient's vital signs (e.g. blood pressure). The device features a first sensor configured to attach to a first portion of the patient's body (e.g. a finger). The sensor includes: i) a first electrode configured to generate a first electrical signal from the first portion of the patient's body; ii) a first light-emitting component; and iii) a first photodetector configured to receive radiation from the first portion of the patient's body and generate a first optical waveform after the radiation is emitted by the first light-emitting component. The device also features a second sensor, configured to attach to a second portion of the patient's body (e.g. a finger on the opposite hand), that includes essentially the same components. An amplifier system, in electrical contact with the first and second electrodes, receives first and second electrical signals from the two sensors to generate an electrical waveform. A processor, in electrical contact with the amplifier system, receives the electrical waveform, the first optical waveform, and the

second optical waveform. The processor runs computer code that processes the input waveforms with an algorithm to determine at least one of the patient's vital signs, and most particularly blood pressure.

[0018] In embodiments, the computer code i) determines a time delay between the first optical waveform and the electrical waveform; and ii) processes the time delay to determine a blood pressure value. In other embodiments, the computer code i) determines a first time delay between the first optical waveform and the electrical waveform; ii) determines a second time delay between the second optical waveform and the electrical waveform; and iii) processes at least one (or both) of the first and second time delays to determine a blood pressure value. In still other embodiments, the computer code i) determines a time delay between the first and second optical waveforms; and ii) process the time delay to determine a blood pressure value.

[0019] In another aspect, the invention features a device for measuring a patient's vital signs (e.g., blood pressure) that includes: 1) a controller; 2) a first sensor, electrically connected to the controller by a first electrical connection and configured to clip to a first finger located on a patient's first hand; and 3) a second sensor, electrically connected to the controller by a second electrical connection and configured to clip to a second finger located on a patient's second hand. Both the first and second sensor include: i) an electrical system configured to generate an electrical signal from the inserted finger; and ii) an optical system featuring at least one light source and a photodetector and configured to generate an optical signal from the inserted finger. A processor receives a processed electrical signal generated from the first and second electrical signals and the optical signal measured from each finger, and operates computer code that processes the signals with an algorithm to determine at least one of the patient's vital signs.

[0020] In embodiments, either (or both) the first or second sensor includes an additional light-emitting component. In this case, the photodetector is typically located on a surface opposite the two light-emitting components and configured so that radiation emitted by both these components passes through the patient's finger and into the photodetector to generate separate signals. These signals, for example, can be processed by the processor to determine a pulse oximetry value. In embodiments, at least one of the light-emitting components is configured to emit infrared radiation (between, e.g., 800 and 1200 nm), red radiation (between, e.g., 600 and 700 nm), or green radiation (between, e.g., 500 and 550 nm) to generate an optical signal.

[0021] In other embodiments, one (or both) of the electrical connections is a cable, e.g. a retractable cable.

[0022] The monitor can additionally include a simple wired or wireless interface that sends vital-sign information to a personal computer. For example, the device can include a Universal Serial Bus (USB) connector that connects to the computer's back panel. Once a measurement is made, the device stores it on an on-board memory and then sends the information through the USB port to a software program running on the computer. Alternatively, the device can include a short-range radio interface (based on, e.g., Bluetooth or 802.15.4) that wirelessly sends the information to a matched short-range radio within the computer. The software program running on the computer then analyzes the information to generate statistics on a patient's vital signs (e.g., average values, standard deviation, beat-to-beat varia-

tions) that are not available with conventional devices that make only isolated measurements. The computer can then send the information through a wired or wireless connection to a central computer system connected to the Internet.

[0023] The central computer system can further analyze the information, e.g. display it on an Internet-accessible website. In this way medical professionals can characterize a patient's real-time vital signs during their day-to-day activities, rather than rely on an isolated measurement during a medical check-up. For example, by viewing this information, a physician can delineate between patients exhibiting white coat syndrome and patients who truly have high blood pressure. Physicians can determine patients who exhibit high blood pressure throughout their day-to-day activities. In response, the physician can prescribe medication and then monitor how this affects the patient's blood pressure.

[0024] These and other advantages of the invention will be apparent from the following detailed description and from the claims.

BRIEF DESCRIPTION OF THE DRAWINGS

[0025] FIGS. 1A and 1B show schematic drawings of the hand-held vital sign monitor according to the invention operating in, respectively, one-time and continuous modes;

[0026] FIGS. 2A, 2B, and 2C show, respectively, graphs of optical and electrical waveforms generated with a first sensor, a second sensor, and optical waveforms generated from both the first and second sensors included in the monitor of FIGS. 1A and 1B;

[0027] FIG. 3 shows a schematic drawing of a patient characterized by the monitor of FIGS. 1A and 1B with blood flowing on their left and right-hand sides;

[0028] FIG. 4 shows a schematic front view of the first and second finger sensors included in the monitor of FIGS. 1A and 1B;

[0029] FIGS. 5A and 4B show schematic side views of the finger sensors of FIG. 4 in, respectively, open and closed configurations;

[0030] FIGS. 6A and 6B show schematic top views of, respectively, top and bottom portions of the finger sensors of FIG. 4;

[0031] FIGS. 7A and 7B show schematic top views of, respectively, top and bottom portions of a patch sensor used in place of the finger sensors of FIG. 4;

[0032] FIG. 8 shows a schematic view of the patch sensor of FIGS. 7A and 7B attached to the patient's hand;

[0033] FIG. 9 shows a schematic view of three patch sensors of FIGS. 7A and 7B attached to the patient's body;

[0034] FIGS. 10A and 10B show schematic views of, respectively, front and back surfaces of the monitor of FIGS. 1A and 1B; and

[0035] FIG. 11 shows a schematic drawing of an in-hospital information system operating with the monitor of FIGS. 1A and 1B.

DETAILED DESCRIPTION OF THE INVENTION

[0036] FIGS. 1A and 1B show two preferred embodiments of the invention wherein a hand-held vital sign monitor 10 measures vital sign information such as systolic and diastolic blood pressure, heart rate, pulse oximetry, temperature, ECG, and an optical plethysmograph from a patient 5. Using

a 'bilateral' measurement technique described in detail below, the monitor **10** measures blood pressure values without using a conventional cuff-based system, and without requiring a complex calibration procedure. Specifically, blood pressure measurements are made with a technique referred to herein as bilateral pulse transit time, or 'BPTT', which is described in more detail in the co-pending patent application entitled 'SYSTEM FOR MEASURING VITAL SIGNS USING BILATERAL PULSE TRANSIT TIME', U.S. Ser. No. 11/420,652, filed May 26, 2006, the contents of which are incorporated herein by reference.

[0037] The same monitor **10** measures vital sign information in two different modes: 1) a one-time mode (FIG. 1A) wherein the monitor **10** makes and stores a single measurement from a patient; and 2) a continuous mode (FIG. 1B) wherein the monitor **10** periodically measures and wirelessly transmits multiple measurements from the patient over an extended period of time. In this way, a single monitor can be used in a wide variety of in-hospital settings, such as characterizing patients requiring just a single vital sign measurement (e.g., patients waiting in a medical clinic) to those requiring more sophisticated continuous monitoring (e.g., critically ill patients in a hospital telemetry ward). The monitor **10** typically features dimensions and a user interface similar to those of a conventional personal digital assistant ('PDA'), and is small enough to fit inside a medical professional's pocket or be worn on a patient's body. The monitor **10** features no cuffs and minimal external wiring to simplify operation.

[0038] In the one-time mode, two sensors **15a**, **15b**, each featuring a 'finger clip' form factor and described in more detail with reference to FIGS. 4, 5A, 5B, 6A, and 6B, connect through cables **13**, **14** to the monitor **10**. The finger clip sensors **15a**, **15b** feature both optical and electrical measurement systems and easily clip onto fingers on the patient's left and right hands to form a 'bilateral' configuration, described in more detail below. In this configuration, each finger clip sensor measures, respectively, optical and electrical waveforms similar to those described with reference to FIGS. 2 and 3. The optical measurement system features a common photodetector and two independent light-emitting systems: 1) an LED emitting green radiation that measures a single optical waveform in a reflection-mode geometry; and 2) a pair of LEDs emitting red and infrared radiation that measure separate optical waveforms in a transmission-mode geometry. The electrical measurement system within each finger clip sensor **15a**, **15b** features a single electrode, typically composed of a conventional electrode material such as brass, stainless steel, or silver/silver chloride. The electrode may additionally include an impedance-matching component, such as a conductive gel or rubber, or a disposable component.

[0039] During operation, the sensor simultaneously measures optical waveforms using both the reflection and transmission-mode optical systems, along with electrical signals using the above-described electrodes. This information passes from the sensors **15a**, **15b**, through the cables **13**, **14**, and to the monitor **10**. The monitor **10** features a first amplifier system and electrical filter that processes the optical waveforms from both fingers to improve their signal-to-noise ratios, and a second amplifier system and electrical filter that processes the electrical signals from both fingers to generate a single electrical waveform, similar to a conventional single-lead ECG. An analog-to-digital converter, typi-

cally integrated within a microprocessor within the monitor, digitizes the optical and electrical waveforms to generate separate arrays of data points which can then be further processed. Specifically, computer algorithms in the monitor **10** process the digitized optical and electrical waveforms measured in the bilateral configuration as described in more detail below to determine the patient's vital signs.

[0040] In the continuous mode, disposable adhesive patch sensors **20a**, **20b**, **20c** attach directly to the patient's chest and arm, and connect to each other and a belt-worn monitor **10'** through the cables **13**, **14**. The patch sensors **20a**, **20b**, **20c**, described in more detail with reference to FIG. 7A and 7B, include both optical and electrical measurement systems similar to the finger clip sensors described above. Specifically, the patch sensors **20a**, **20b**, **20c** include green, red, and infrared LEDs and a common photodetector. The LEDs and photodetector are configured so that, when the patch sensor attaches to the patient's finger (e.g., patch sensor **20c**), the green LED and photodetector measure an optical waveform using a reflection-mode geometry, and the red and infrared LEDs and the photodetector measure optical waveforms using a transmission-mode geometry. This geometry is shown in more detail in FIG. 8. When the patch sensor is attached to the patient's chest, the green LED and photodetector measure an optical waveform in a reflection-mode geometry, while measurements in a transmission mode geometry are typically not possible. Regardless of their positioning, electrodes within the adhesive patch sensors **20a**, **20b**, **20c** measure electrical signals from the patient's finger and chest.

[0041] Optical waveforms and electrical signals measured by the adhesive patch sensors **20a**, **20b**, **20c** are processed by circuitry within the belt-worn monitor **10'** to determine the patient's vital signs. Both the monitor **10** and the belt-worn monitor **10'** additionally include a short-range wireless system that transmits the vital signs to a number of possible devices, each of which includes a matched short-range wireless system. For example, the belt-worn monitor **10'** can transmit vital sign information to: 1) the hand-held monitor **10** (as indicated by arrow **16a**); 2) a remote computer **33** (as indicated by arrow **16b**); or 3) a wall-mounted display **30** (e.g., an LCD or plasma screen, as indicated by arrow **16c**). The belt-worn monitor **10'** can transmit vital sign information in response to a command (sent, e.g., from the hand-held monitor **10**), or periodically according to one or more pre-programmed values.

[0042] Referring to FIGS. 2A, 2B, 2C, the monitor **10** measures blood pressure using BPTT by processing optical waveforms **29A**, **29B** and electrical waveforms **31A**, **31B** measured simultaneously from each side of the patient's body. Each waveform includes a 'pulse' that corresponds to each of the patient's heartbeats. In the electrical waveforms **31A**, **31B**, this pulse represents electrical signals generated by the beating heart, and includes a sharply varying 'peak' within a conventional QRS complex of the ECG. In contrast, for the optical waveforms **29A**, **29B**, the pulse varies more gradually and represents a time-dependent volumetric change in an underlying artery. A microprocessor in the monitor **10** calculates a pulse transit time ('PTT'), described in more detail below, by analyzing a time difference ΔT between a point on the optical **29A**, **29B** and electrical **31A**, **31B** waveforms (e.g., ΔT between the peaks of these waveforms). Specific points on the waveforms, such as their maxima or minima, can be determined by taking a first or

second derivative of the waveform. ΔT measured from the optical waveform 29A from the patient's left index finger and the electrical waveform 31A is shown in FIG. 2A (labeled ΔT_L). Similarly, ΔT measured from the optical waveform 29B from the right index finger and the electrical waveform 31B is shown in FIG. 2B (labeled ΔT_R).

[0043] In the one-time mode, a BPTT measurement processes PTTs measured with the finger clip sensors from the patient's left finger (ΔT_L) and right finger (ΔT_R) to make an accurate measurement of blood pressure. Specifically, PTT depends on several factors, including blood pressure, distance between the heart and the portion of the body where the optical waveform is measured (e.g., the patient's finger), and properties of the patient's vasculature (e.g., arterial compliance, size, and stiffness).

[0044] BPTT as described herein can potentially improve the accuracy of a normal PTT measurement. For example, as shown in FIG. 3, a patient's heart 48 is typically located in a relatively well-defined position on the left-hand side of their chest cavity. With each heartbeat, blood simultaneously flows along a right-hand vascular pathlength 44A to reach a point 42A on the patient's right hand, and along a left-hand vascular pathlength 44B to reach a point 42B on the patient's left hand. The right-hand vascular pathlength 44A typically differs from the left-hand vascular pathlength 44B. The difference in pathlengths can correlate with the patient's biometric parameters (e.g., height, arm span). The difference in pathlengths and corresponding difference in PTTs can be used in the calculation of the patient's vital signs (e.g., blood pressure), as is described in more detail below.

[0045] Following a heartbeat, electrical impulses travel essentially instantaneously from the patient's heart to electrodes within each finger clip or adhesive patch sensor, which detect it to generate an electrical waveform. At a later time, a pressure wave induced by the same heartbeat simultaneously propagates through the patient's right-hand 44A and left-hand 44B vascular pathlengths. At points 42A, 42B on the patient's left and right hands, elastic arteries within these vascular pathlengths increase in volume due to the pressure wave. Ultimately the pressure wave arrives at a portion of the artery underneath the LED and photodetector within each sensor. These optics combine to form an optical system that detects the pressure wave by measuring a time-dependent change in optical absorption. The propagation time of the electrical impulse is independent of blood pressure, whereas the propagation time of the pressure wave depends strongly on pressure, as well as properties of the patient's arteries.

[0046] Referring again to FIGS. 2A, 2B, and 2C, during a BPTT measurement, optical sensors within the right and left finger clip or adhesive patch sensors simultaneously measure optical waveforms 29A, 29B, while electrodes in the sensors measure electrical waveforms 31A, 31B. The optical waveforms 29A, 29B are unique to each area underneath the sensor, while the electrical waveforms 31A, 31B are identical, and are determined by combining electrical signals from multiple sensors. A microprocessor within the monitor runs an algorithm that analyzes the time difference $\Delta T_{L,R}$ between the arrivals of these signals, i.e. the relative occurrence of the optical 29A, 29B and electrical 31A, 31B waveforms for both the right-hand 44A and left-hand 44B vascular system. The microprocessor additionally analyzes the time difference ΔT_O between the arrival of the two optical signals 29A, 29B.

[0047] In a BPTT measurement, the asymmetric position of the heart, coupled with the assumption that blood pressure is equivalent along the left-hand 44B and right-hand 44A vascular pathlengths, means the PTT for the right-hand pathlength 44A will typically be slightly longer than the PTT for the left-hand pathlength 44B. This time difference, ΔPTT , is the difference between ΔT_L and ΔT_R (i.e. $\Delta PTT = \Delta T_R - \Delta T_L$) and can be used to estimate the patient's arm length if a speed of the propagating pressure pulse, called a pulse wave velocity ('PWV') is assumed. Inclusion of arm length in a PTT-based measurement typically improves accuracy for both systolic and diastolic blood pressure. Use of BPTT to determine ΔPTT means arm length can be estimated without having to enter it through a software user interface. Alternatively, the arm length can be entered into a user interface associated with the monitor, and then processed along with ΔPTT to calculate a PWV. This is done by using the above-described assumptions describing the asymmetrical position of the heart. Blood pressure is known to depend strongly on PWV (typically an increase in PWV indicates an increase in blood pressure), and thus a measured PWV value can be compared to a look-up table stored in memory to calculate blood pressure. Alternatively, a mathematical algorithm, such as a predetermined relationship (e.g., a linear relationship) between PWV and blood pressure, may be used to calculate subsequent blood pressure values.

[0048] Referring to FIG. 2C, in another embodiment the time difference ΔT_O between points (e.g., peaks) on two optical signals measured at different locations on the patient's body can be processed to determine a PWV. For example, separate patch sensors 20b, 20c located, respectively, on the patient's chest and finger can measure the arrival of a pulse wave following each heart beat. As described above, the distance between the patch sensors 20b, 20c divided by the time difference ΔT_O yields a PWV, which can then be compared to a look-up table stored in memory or processed with a more sophisticated algorithm to calculate blood pressure. For example, the algorithm may use a predetermined relationship (e.g. a linear relationship) between PWV and blood pressure to calculate subsequent blood pressure values.

[0049] In addition, with the BPTT measurement, optical waveforms measured from the patient's left and right hands or ΔPTT can be compared to determine slight differences in waveform shape. These slight differences can then be processed to achieve a more accurate calculation of the patient's blood pressure. For example, the differences in left and right waveform shapes or arrival times measured as described above can be used to determine a particular mathematical model for calculating blood pressure from a patient, or alternatively properties other than blood pressure. An abnormally high or negative ΔPTT , for example, may indicate a profound difference between a patient's right-hand 44A and left-hand 44B vascular pathlength. Such a difference, for example, may indicate the presence of an occlusion (e.g., a blood clot) or stenosis in either vascular pathlength. In related embodiments, the ΔPTT or waveform shape differences may be used to estimate a patient's arterial compliance. For example, the differences in the patient's right-hand 44A and left-hand 44B vascular pathlengths will result in corresponding differences in the diffusion of light-absorbing blood cells in the two pathlengths. These differences in cellular diffusion are observed as differences in the shapes of

the optical waveforms 29A and 29B. The waveform shape differences will depend on the arterial compliance along the right-hand 44A and left-hand 44B vascular pathlengths. For example, the optical signals (29A, 29B) shown in FIGS. 2A, 2B, 2C typically feature a main peak and a secondary peak, where the secondary peak is typically classified as a 'dichrotic notch'. Studies published in the literature describe how the dichrotic notch, particularly when analyzed by taking a second derivative of the plethysmogram, relates to vascular compliance (see, e.g., 'Assessment of Vasoactive Agents and Vascular Aging by the Second Derivative of Photoplethysmogram Waveform', Takazawa et. al, Hypertension 32: 365-370, 1998; the contents of which are incorporated herein by reference). Arterial compliance determined using this or another method can then be used to group patients having similar arterial properties. An algorithm can then process ΔPTT or PWV values for patients in a particular group, or compare these values to predetermined look-up tables, to make a blood pressure measurement. For example, the algorithm may use a predetermined relationship (e.g. a linear relationship) between PWV or ΔPTT and blood pressure to calculate subsequent blood pressure values.

[0050] Referring again to FIGS. 2A, 2B, and 2C, in yet another embodiment, processing the electrical waveform 31A, 31B and optical waveforms 29A, 29B can be used to estimate a property called pre-ejection period (' ΔT_{PEP} '), which is the time delay between the beginning of a patient's heart beat and the beginning of the patient's cardiac stroke. Specifically, both ΔT_R and ΔT_L depend on ΔT_{PEP} and the time it takes the pressure pulse to leave the heart and arrive at the optical system underneath a corresponding sensor. As shown in FIG. 2C, this time difference, referred to as ΔT_O , can be measured directly from patch sensors located near the patient's heart and finger. If the patch sensor is located on the patient's right hand, $\Delta T_R - \Delta T_O = \Delta T_{PEP}$, while if the patch sensor is located on the patient's left hand $\Delta T_L - \Delta T_O = \Delta T_{PEP}$. ΔT_{PEP} correlates with the patient's systolic function, with a shorter ΔT_{PEP} typically indicating a relatively healthy systolic function. A measured ΔT_{PEP} can be used in conjunction with the time difference between a feature on the electrical waveform and one or more features on one or more optical waveforms to improve the accuracy of the calculated PTT and corresponding blood pressure. In particular, it has been shown in previous studies that systolic blood pressure can correlate better to a ΔPTT value, whereas diastolic blood pressure and mean arterial blood pressure can correlate better to a ΔPTT value corrected for ΔT_{PEP} , i.e. $\Delta PTT - \Delta T_{PEP}$ (see, e.g., 'Pulse transit time measured from the ECG: an unreliable marker of beat-to-beat blood pressure', Payne et. al, J. Appl. Physiol 100: 136-141, 2006; the contents of which are incorporated herein by reference). ΔT_{PEP} values may also vary with respiration and inspiration, thereby affecting the measured blood pressure. For this reason, in embodiments, computer code operating in the monitor described above can first process two optical waveforms to estimate ΔT_{PEP} . Once this is done, the computer code can determine ΔPTT and $\Delta PTT - \Delta T_{PEP}$, which are then used to calculate, respectively, systolic and diastolic blood pressure.

[0051] FIGS. 4, 5A, 5B, 6A, and 6B show the above-described finger clip sensors 15a, 15b of FIG. 1A in more detail. As described above, finger clips sensors 15a, 15b are typically used in a one-time measurement mode. Each finger

clip sensor 15a, 15b is designed to gently clip onto an index finger on the patient's left and right hands, and features a top portion 70a, 70b connected to a bottom portion 72a, 72b by a spring-loaded backing portion 62a, 62b. This configuration ensures that, during operation, each finger clip sensor secures to the patient's finger and blocks out ambient light, thereby increasing the signal-to-noise ratio of both the optical and electrical measurements. As described above, the bottom portion 72a, 72b features an electrode material 60a, 60b that contacts a bottom portion of the patient's finger when the finger clip sensor is closed. The electrode material 60a, 60b is typically a metal, such as brass or copper, or a conventional electrode such as silver/silver chloride. The electrode material 60a, 60b may also include an impedance-matching material, such as a conductive gel or rubber. Electrical signals measured with electrode materials 60a, 60b from the left 15a and right 15b finger clip sensors pass through cables 13, 14 to the monitor, where they are processed with an amplifier circuit and then digitized to generate an electrical waveform similar to a conventional ECG. Unlike the optical waveforms, which specifically correspond to each blood flowing in each index finger, a single electrical waveform is determined by jointly processing electrical signals measured from each index finger using the amplifier circuit.

[0052] The bottom portion 72a, 72b of the finger clip sensor 15a, 15b additionally includes a photodiode 66a, 66b and a green LED 68a, 68b disposed on the same surface, and typically separated from each other by about 1-2 mm. During operation, radiation from the green LED 68a, 68b reflects off the patient's finger and its underlying arteries to generate reflected radiation, which the photodiode 66a, 66b detects to generate a time-dependent optical waveform. This waveform is measured in a reflection-mode geometry, and because it is not used to calculate pulse oximetry, can typically be measured at a relatively high frequency (e.g., several kHz) and resolution (8-16-bit). Typically the photodiode 66a, 66b and green LED 68a, 68b are seated below a soft rubber material so that they don't make direct contact with skin on the bottom surface of the patient's finger. The top portion 70a, 70b includes a red LED 64a, 64b and an infrared LED which sequentially emit radiation that, during operation, transmits through the patient's index finger and its underlying arteries. Some radiation that passes through the arteries exposes the photodiode 66a, 66b, which in response generates a pair of time-dependent optical waveforms (one from each of the red and infrared LEDs). These waveforms are measured in a transmission-mode geometry. During operation, the optical waveforms measured in both transmission and reflection modes pass through the cables 13, 14 to the monitor, where they are processed as described above to measure the patient's vital signs. Blood pressure values are calculated as described above. Heart rate values can be calculated by processing the optical and electrical waveforms using techniques known in the art. Pulse oximetry values can be calculated by collectively processing waveforms generated by the red and infrared LEDs using techniques known in the art.

[0053] FIGS. 7A, 7B, 8 and 9 show the adhesive patch sensors 20a, 20b, 20c of FIG. 1B in more detail. As described above, the adhesive patch sensors 20a, 20b, 20c are typically used in a continuous measurement mode. Each sensor features a green LED 88 positioned proximal to a photodiode 86, both of which are disposed on a flexible

printed circuit board **87**. When the sensor is attached to a patient, these optical components generate an optical waveform as described above. A horseshoe-shaped metal electrode **80** formed on top of the flexible printed circuit board **87** surrounds these optical components and generates an electrical signal that, when processed in concert with another electrical signal from a separate electrode, generates an electrical waveform. Red **84** and infrared **85** LEDs are additionally mounted on an opposite end of the flexible printed circuit board. When the sensor is attached to a patient's finger, as shown in FIG. **8**, the red **84** and infrared **85** LEDs generate radiation that passes through the finger and into the photodiode **86**, as described above, to generate separate optical waveforms in a transmission-mode geometry. On its outer surface the sensor includes a snap connector **89** that allows it to easily attach and detach to a cable **13**. All electrical signals and optical waveforms, once generated, pass through the cable **13** to the monitor, which analyzes them as described above to measure a patient's vital sign information. The patch sensor **20** additionally features an adhesive component **91**, similar to that in a common band-aid or ECG electrode, which adheres to the patient's skin and secures the sensor in place to minimize the effects of motion.

[0054] Both the cable **13** and snap connector **89** include matched electrical leads that supply power and ground to the LEDs **84**, **85**, **88**, photodetector **86**, and electrode **80**. When the patch sensor **20** is not measuring optical and electrical waveforms, the cable **13** unsnaps from the snap connector **89**, while the sensor **20** remains adhered to the patient's skin. In this way a single sensor can be used for several days. After use, the patient removes and then discards the sensor **20**.

[0055] FIGS. **10A** and **10B** show, respectively, front and back surfaces of the monitor **10**. The front surface (FIG. **10A**) features a touch-screen display **100** rendering a graphical user interface that operates in both one-time and continuous modes. A removable stylus **108** is housed in a slot on a top surface of the monitor and is used to operate the user interface through the touch-screen display **100**. The monitor **10** typically includes separate antennae **102**, **104** for, respectively, short-range communications (for, e.g., part-15 or 802.11-based networks) and long-range communications (for, e.g., CDMA networks). The antenna **102** for short-range communication typically communicates with peripheral devices, such as the belt-worn monitor, a wireless scale, chest strap, thermal printer, external monitor, or local personal computer. The antenna **104** for long-range communications is typically used to send information through a wireless network to an Internet-based computer system. The monitor also includes an on/off button **112** and a USB connector **110** for downloading information to a personal computer and recharging the monitor's battery through a cable.

[0056] On its back surface (FIG. **10B**) the monitor **10** includes a mechanical mechanism **114** that retracts both cables **13**, **14** when they're not in use. In this way the monitor can be kept as compact as possible with minimal external components. Alternatively, the mechanical mechanism **114** can be replaced with a simple connector that mates with a connector terminating both cables **13**, **14**. In other embodiments, the monitor can also include a bar code scanner **115** that reads conventional bar-coded information from, e.g., a patient's wrist band. Typically the bar code

scanner **115** connects to a microprocessor through a serial interface. In other embodiments, a thermometer **116** for measuring body temperature connects to the monitor **10** through either a wired or wireless interface.

[0057] FIG. **11** shows a preferred embodiment of an Internet-based system **152** that operates in concert with the hand-held monitor **10** and body-worn monitor **10'** to send information from a patient **130** to an in-hospital information system **171**. Using the hand-held monitor **10**, a medical professional **131** collects vital sign information from the patient's body-worn monitor **10'** through a short-range wireless connection **16a**. Alternatively, the body-worn monitor **10'** automatically transmits vital sign information in a continuous or near-continuous manner. In both cases, using an internal wireless modem, information travels from either the hand-held monitor **10** or body-worn monitor **10'** through a wireless interface **16b** to a wireless network **154** (e.g., either a nation-wide or local wireless network), and from there to a web site **166** hosted on an Internet-based host computer system **33**. A secondary computer system **169** accesses the website **166** through the Internet **167**. A wireless gateway **155** connects to the host computer system **33** and ultimately to the wireless network **154**, and receives data from one or more monitors, as discussed below. The host computer system **33** includes a database **163** and a data-processing component **168** for, respectively, storing and analyzing data sent from the monitor. The host computer system **33**, for example, may include multiple computers, software systems, and other signal-processing and switching equipment, such as routers and digital signal processors. The wireless gateway **155** preferably connects to the wireless network **154** using a TCP/IP-based connection, or with a dedicated, digital leased line (e.g., a VPN, frame-relay circuit or digital line running an X.25 or other protocols). The host computer system **33** also hosts the web site **166** using conventional computer hardware (e.g. computer servers for both a database and the web site) and software (e.g., web server and database software). To connect to the in-hospital information system **171** (e.g., a system for electronic medical records), the host computer system **33** typically includes a web services interface **170** that sends information using an XML-based web services link to a computer associated with the in-hospital information system **171**. Alternatively, the wireless network **154** may be an in-hospital wireless network (e.g., a network operating Bluetooth™, 802.11a, 802.11b, 802.11g, 802.15.4, or 'mesh network' wireless protocols) that connects directly to the in-hospital information system **171**. In this embodiment, a nurse working at a central nursing station can quickly view the vital signs of the patient using a simple computer interface.

[0058] To view information remotely, the patient or medical professional can access a user interface hosted on the web site **166** through the Internet **167** from a secondary computer system **169**, such as an Internet-accessible home computer. The system may also include a call center, typically staffed with medical professionals such as doctors, nurses, or nurse practitioners, whom access a care-provider interface hosted on the same website **166**.

[0059] Other embodiments are also within the scope of the invention. For example, PTT can be used to first determine mean arterial pressure (MAP) as opposed to systolic blood pressure (BP SYS) or diastolic blood pressure (BP DIA). In this case, a predetermined relationship between PTT and MAP is established. In subsequent measurements, PTT is

measured and used to calculate MAP. The optical waveform can then be analyzed to estimate pulse pressure (i.e., BP SYS-BP DIA), which can then be used along with MAP to estimate both BP SYS and BP DIA using the formula:

$$\text{MAP} = \text{BP SYS} + \frac{1}{3}(\text{BP SYS} - \text{BP DIA})$$

[0060] In still other embodiments, the body-worn monitor can optionally be used to determine the patient's location using embedded position-location technology (e.g., GPS, network-assisted GPS, or Bluetooth™, 802.11-based location system). In situations requiring immediate medical assistance, the patient's location, along with relevant vital sign information, can be relayed to emergency response personnel.

[0061] Still other embodiments are within the scope of the following claims.

We claim as our invention:

1. A method for measuring a blood pressure of a user, the method comprising:

generating a first optical waveform from a signal from a first optical sensor positioned on the user;

generating a second optical waveform from a signal from a second optical sensor positioned on the user, the second optical waveform generated simultaneously with the first optical waveform, the second optical sensor positioned a distinguishable distance from the first optical sensor on the user;

generating an electrical waveform from a signal from a first electrode positioned in proximity with the first optical sensor and a signal from a second electrode positioned in proximity with the second optical sensor;

determining a first pulse transit time, the first pulse transit time calculated by processing the electrical waveform and the first optical waveform;

determining a second pulse transit time, the second pulse transit time calculated by processing the electrical waveform and the second optical waveform; and

processing the first pulse transit time and the second pulse transit time to determine a blood pressure value for the user.

2. The method of claim 1, wherein determining the first pulse transit time further comprises determining a first point on the first optical waveform or a processed version thereof, determining a second point on the electrical waveform or a processed version thereof, and determining a time difference between the first and second points.

3. The method of claim 2, further comprising determining a mathematical derivative of the first optical waveform, and then determining the first point from a maximum value of the mathematical derivative of the first optical waveform.

4. The method of claim 1, wherein determining the second pulse transit time further comprises determining a first point on the second optical waveform or a processed version thereof, determining a second point on the electrical waveform or a processed version thereof, and then determining a time difference between the first and second points.

5. The method of claim 4, further comprising determining a mathematical derivative of the second optical waveform, and then determining the first point from a maximum value of the mathematical derivative of the second optical waveform.

6. The method of claim 1, wherein the processing further comprises comparing at least one of the first pulse transit

time and the second pulse transit time to a predetermined mathematical relationship between pulse transit time and blood pressure.

7. The method of claim 1, further comprising processing at least one of the first optical waveform and the second optical waveform to determine a property related to arterial compliance.

8. The method of claim 7, further comprising taking a second mathematical derivative of at least one of the first optical waveform and the second optical waveform, and then processing the second derivative to determine a property related to arterial compliance.

9. The method of claim 1, further comprising comparing the first optical waveform and the second optical waveform to determine a property related to blood flow along two different arterial pathways of the user.

10. The method of claim 1, further comprising processing the first optical signal or a processed version thereof and the second optical signal or a processed version thereof to determine a third pulse transit time.

11. The method of claim 10, further comprising processing the third pulse transit time to determine a blood pressure value for the user.

12. A method for measuring a blood pressure of a user, the method comprising:

generating a plurality of optical waveforms, each of the plurality of optical waveforms generated from a signal from an optical sensor, wherein each optical sensor is positioned a distinguishable amount from any other optical sensor on the user;

generating an electrical waveform from a plurality of signals, each of the plurality of signals generated from an electrode positioned in proximity to an optical sensor;

determining a plurality of pulse transit times, each of the plurality of pulse transit times calculated by processing the electrical waveform and at least two optical waveforms;

processing each of the plurality of pulse transit times to determine a blood pressure value for the user.

13. The method of claim 12, further comprising determining a first pulse transit time by processing a first optical waveform and the electrical waveform, and a second pulse transit time by processing a second optical waveform and the electrical waveform.

14. The method of claim 13, wherein determining the first pulse transit time further comprises determining a first point on the first optical waveform or a processed version thereof, determining a second point on the electrical waveform or a processed version thereof, and determining a time difference between the first and second points.

15. The method of claim 14, further comprising determining a mathematical derivative of the first optical waveform, and then determining the first point from a maximum value of the mathematical derivative of the first optical waveform.

16. The method of claim 13, wherein determining the second pulse transit time further comprises determining a first point on the second optical waveform or a processed version thereof, determining a second point on the electrical waveform or a processed version thereof, and then determining a time difference between the first and second points.

17. The method of claim 16, further comprising determining a mathematical derivative of the second optical

waveform, and then determining the first point from a maximum value of the mathematical derivative of the second optical waveform.

18. The method of claim **13**, wherein the processing further comprises comparing at least one of the first pulse transit time and the second pulse transit time to a predetermined mathematical relationship between pulse transit time and blood pressure.

19. The method of claim **13**, further comprising processing the first optical signal or a processed version thereof and the second optical signal or a processed version thereof to determine a third pulse transit time.

20. The method of claim **19**, further comprising processing the third pulse transit time to determine a blood pressure value for the user.

21. A method for measuring a blood pressure of a user, the method comprising:

generating a first optical waveform from a signal from a first optical sensor positioned on a finger of a right-hand of the user;

generating a second optical waveform from a signal from a second optical sensor, the second optical waveform generated simultaneously with the first optical waveform, the second optical sensor positioned on a finger of a left-hand of the user;

generating an electrical waveform from a signal from a first electrode positioned in proximity with the first optical sensor and a signal from a second electrode positioned in proximity with the second optical sensor;

determining a first pulse transit time, the first pulse transit time calculated by processing the electrical waveform and the first optical waveform;

determining a second pulse transit time, the second pulse transit time calculated by processing the electrical waveform and the second optical waveform; and

processing the first pulse transit time and the second pulse transit time to determine a blood pressure value for the user.

22. A method for measuring a blood pressure of a user, the method comprising:

generating a first optical waveform from a signal from a first optical sensor positioned on the user;

generating a second optical waveform from a signal from a second optical sensor positioned on the user, the second optical waveform generated simultaneously with the first optical waveform, the second optical sensor positioned a distinguishable amount from the first optical sensor on the user;

generating an electrical waveform from a signal from a first electrode positioned in proximity with the first optical sensor and a signal from a second electrode positioned in proximity with the second optical sensor;

determining a pulse transit time, the pulse transit time calculated by processing the first optical waveform and the second optical waveform; and

processing the pulse transit time to determine a blood pressure value for the user.

* * * * *

专利名称(译)	用于监测生命体征的双侧装置，系统和方法		
公开(公告)号	US20070276262A1	公开(公告)日	2007-11-29
申请号	US11/420744	申请日	2006-05-27
[标]申请(专利权)人(译)	TRIAGE WIRELESS		
申请(专利权)人(译)	TRIAGE WIRELESS, INC.		
当前申请(专利权)人(译)	SOTERA WIRELESS		
[标]发明人	BANET MATTHEW JOHN THOMPSON MICHAEL JAMES ZHOU ZHOU VISSER HENK		
发明人	BANET, MATTHEW JOHN THOMPSON, MICHAEL JAMES ZHOU, ZHOU VISSER, HENK		
IPC分类号	A61B5/02 A61B5/00		
CPC分类号	A61B5/02255 A61B5/02427 A61B5/7239 A61B5/6826 A61B5/6838 A61B5/0285		
其他公开文献	US7803120		
外部链接	Espacenet USPTO		

摘要(译)

本发明的特征在于一种测量患者生命体征（例如血压）的监测装置。该装置的特征在于第一传感器，其被配置为附接到患者身体的第一部分，其包括：i) 第一电极，其被配置为从患者身体的第一部分产生第一电信号；ii) 第一发光组件；iii) 第一光电检测器，被配置为在第一发光部件发射辐射之后接收来自患者身体的第一部分的辐射，并且作为响应产生第一光学波形。该设备还具有第二传感器，其基本上包括相同的组件。与第一和第二电极电接触的放大器系统接收来自两个传感器的第一和第二电信号以产生电波形。与放大器系统电接触的处理单元接收电波形，第一光学波形和第二光学波形。处理单元运行计算机代码，该计算机代码利用算法处理输入波形以确定患者的生命体征中的至少一个。

