



(19) **United States**

(12) **Patent Application Publication** (10) **Pub. No.: US 2006/0189859 A1**
Kiani et al. (43) **Pub. Date: Aug. 24, 2006**

(54) **PULSE OXIMETRY SENSOR ADAPTER**

Publication Classification

(76) Inventors: **Massi E. Kiani**, Laguna Niguel, CA (US); **Robert A. Smith**, Lake Forest, CA (US); **David R. Tobler**, Mission Viejo, CA (US)

(51) **Int. Cl.**
A61B 5/00 (2006.01)
(52) **U.S. Cl.** **600/323**

Correspondence Address:
KNOBBE MARTENS OLSON & BEAR LLP
2040 MAIN STREET
FOURTEENTH FLOOR
IRVINE, CA 92614 (US)

(57) **ABSTRACT**

(21) Appl. No.: **11/341,999**
(22) Filed: **Jan. 27, 2006**

An adapter allows the interconnection of a sensor originating from one manufacturer to be coupled with conventionally incompatible monitors originating from other manufacturers to form a properly functioning pulse oximetry system. The adapter matches a sensor driver in a monitor to the current requirements and light source configuration of a sensor. The adapter also matches a sensor's light detector signal level to the dynamic range requirements of a monitor preamplifier. Further, the adapter provides compatible sensor calibration, sensor type and security information to a monitor. The adapter may have a self-contained power source or it may derive power from the monitor, allowing both passive and active adapter components. The adapter is particular suited as an adapter cable, replacing a conventional patient cable or sensor cable as the interconnection between a sensor to a monitor in a pulse oximetry system.

Related U.S. Application Data

(60) Continuation of application No. 10/624,446, filed on Jul. 22, 2003, now Pat. No. 6,993,371, which is a continuation of application No. 09/982,453, filed on Oct. 17, 2001, now Pat. No. 6,597,933, which is a division of application No. 09/404,060, filed on Sep. 23, 1999, now Pat. No. 6,349,228, which is a continuation of application No. 09/021,957, filed on Feb. 11, 1998, now Pat. No. 5,995,855.

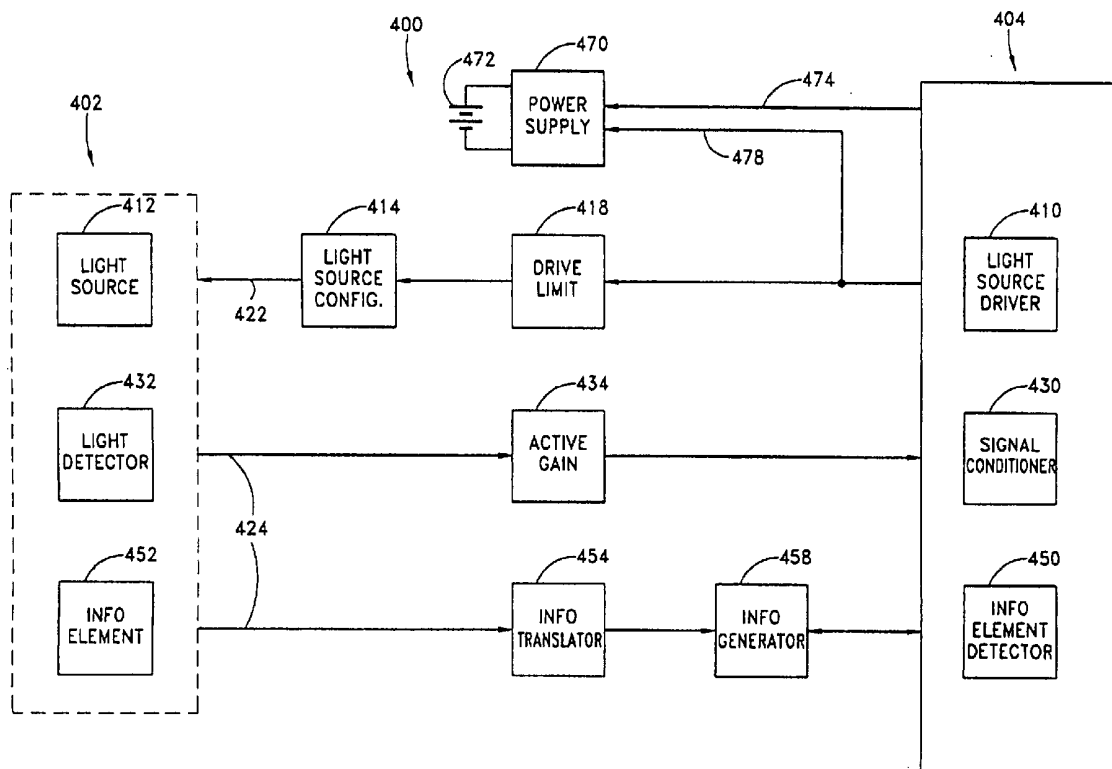

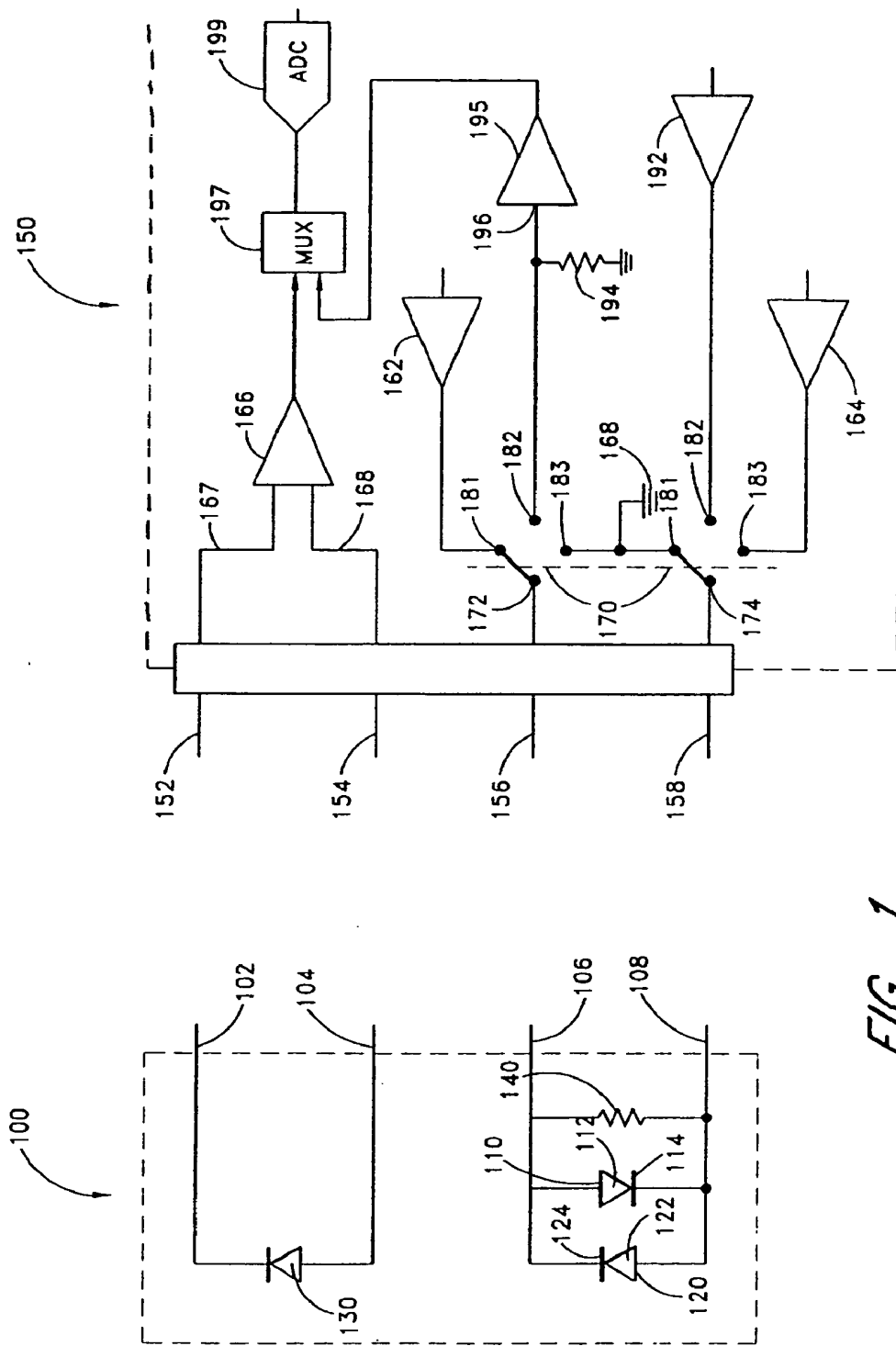

FIG. 1
(PRIOR ART)

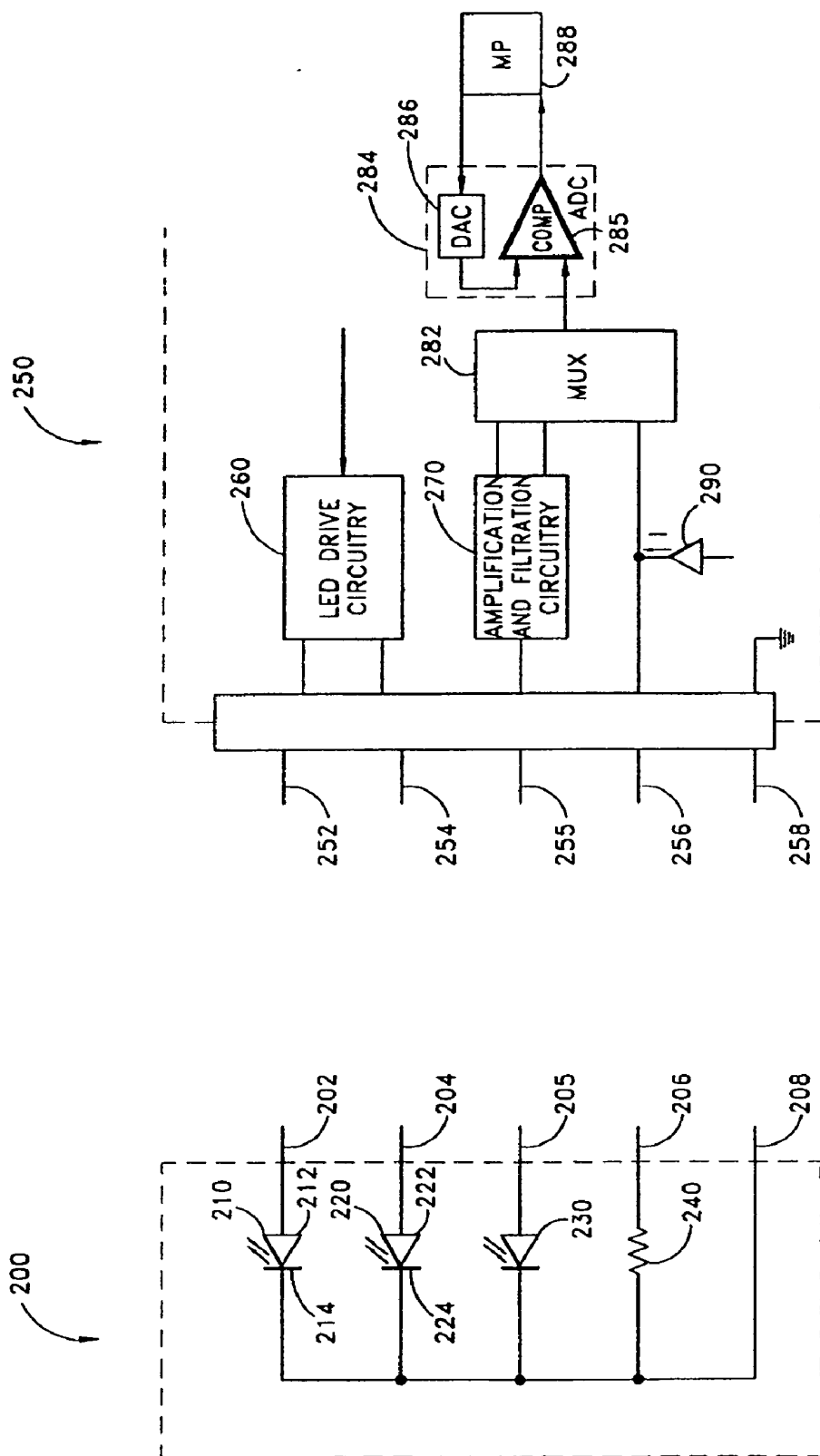

FIG. 2
(PRIOR ART)

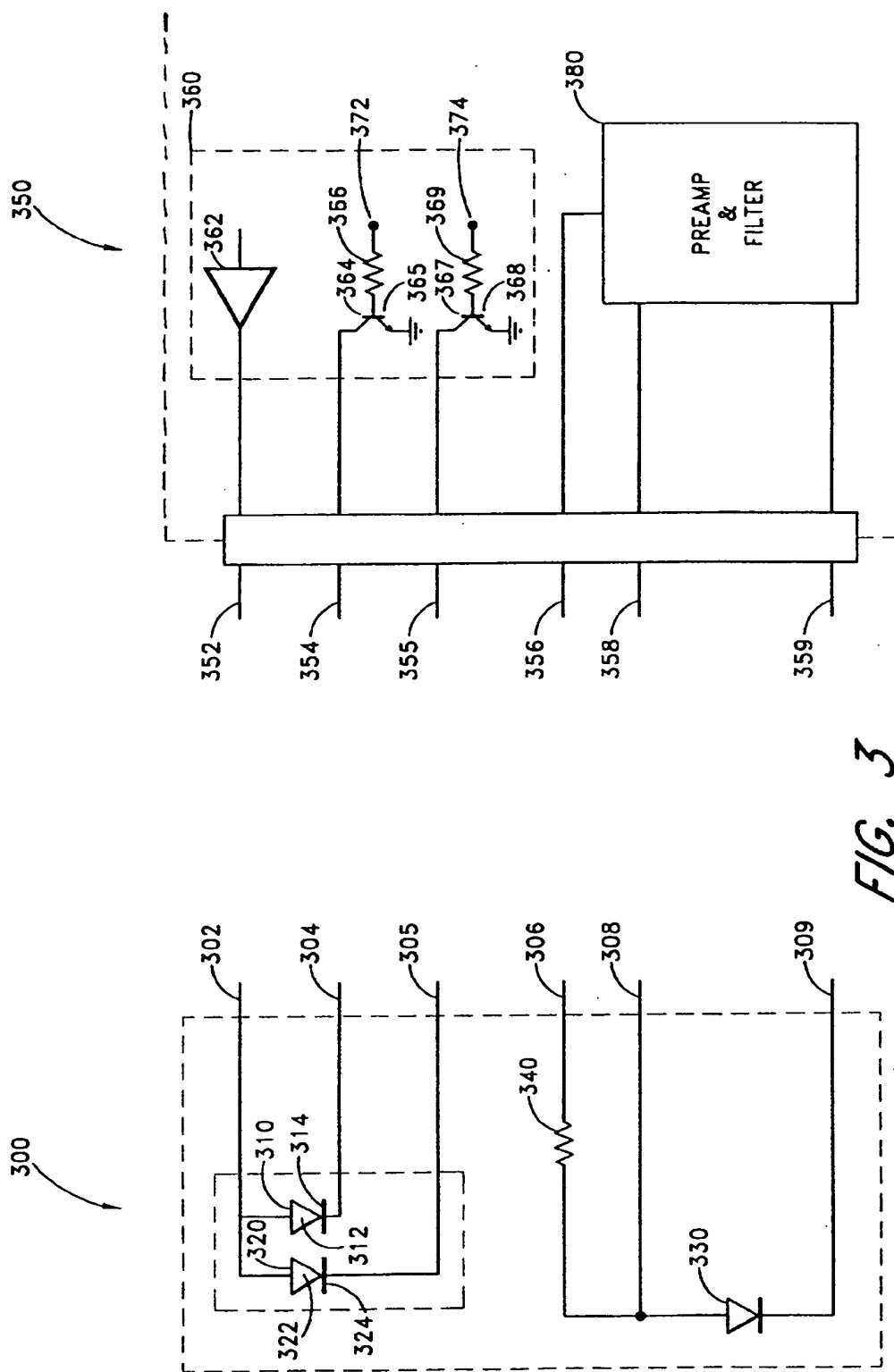

FIG. 3
(PRIOR ART)

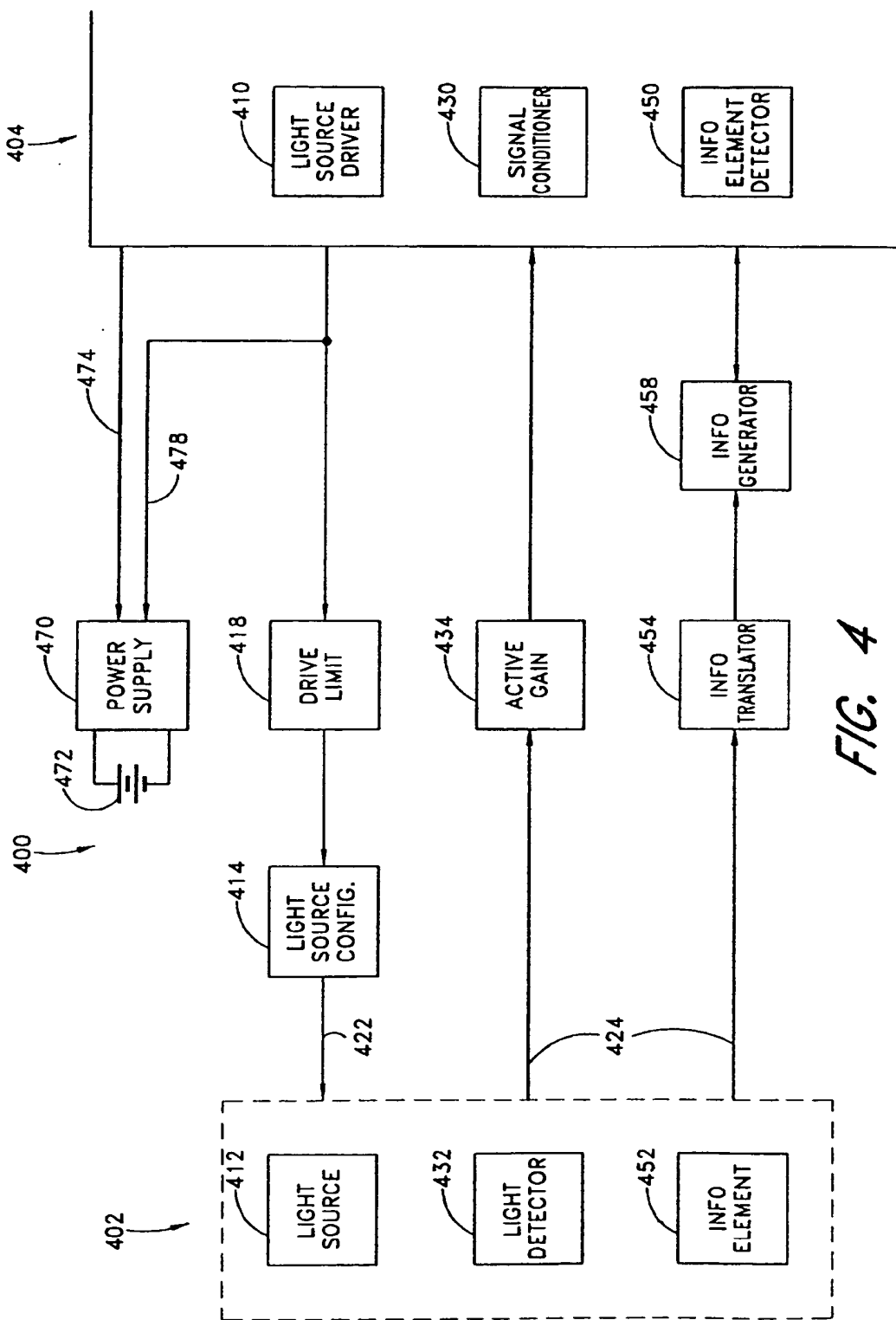

FIG. 4

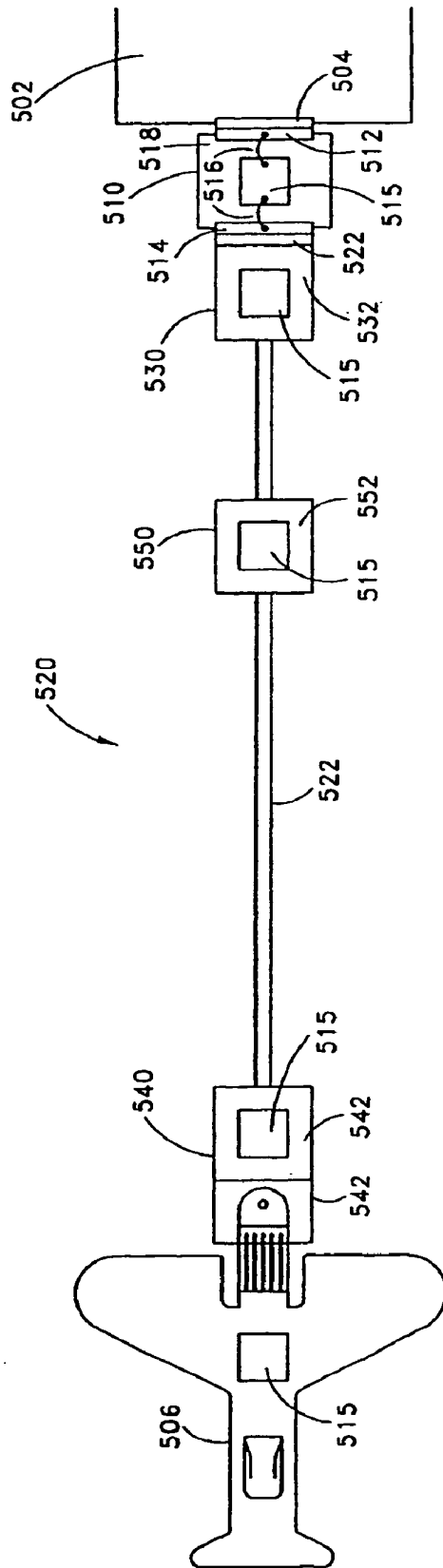

FIG. 5

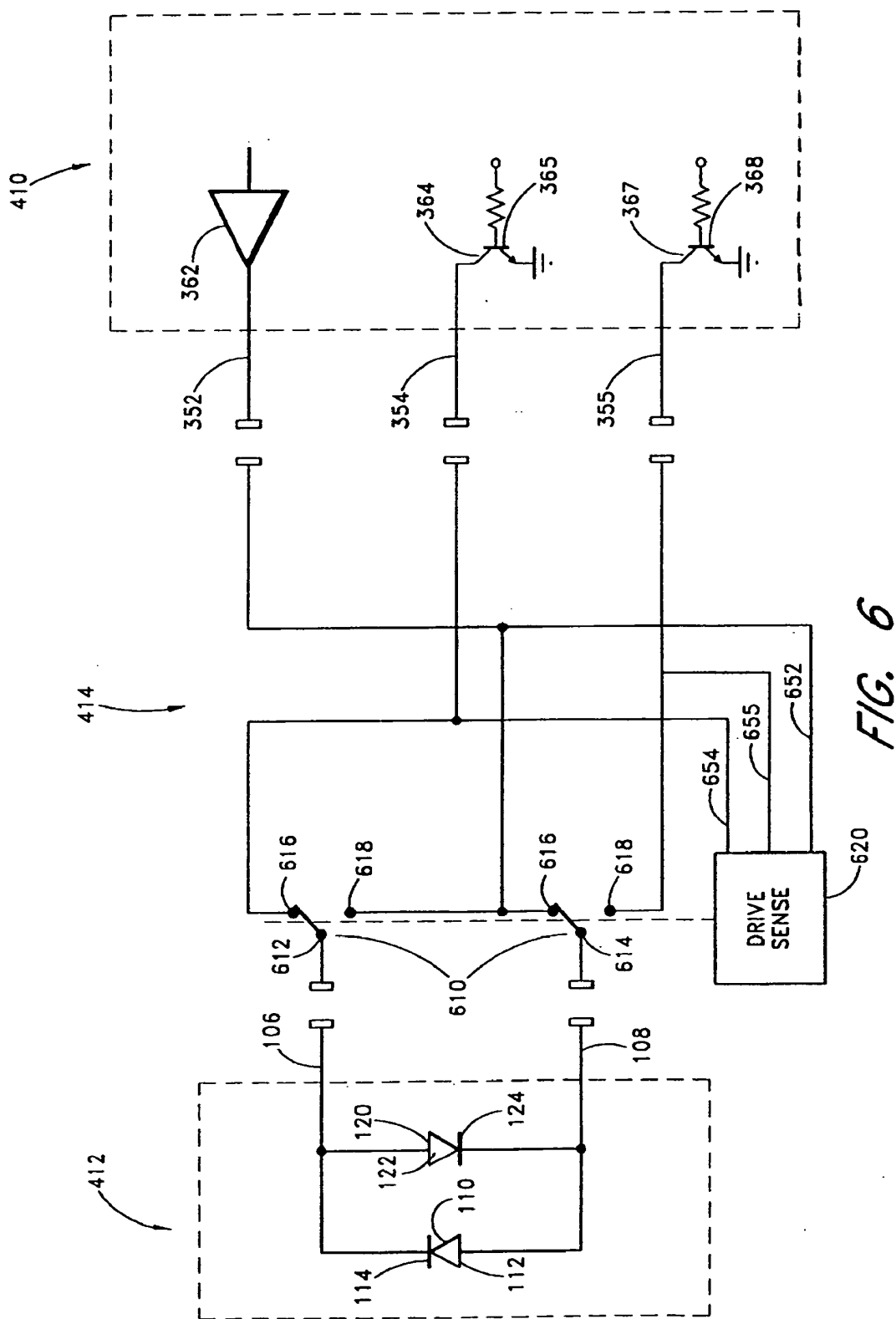

FIG. 6

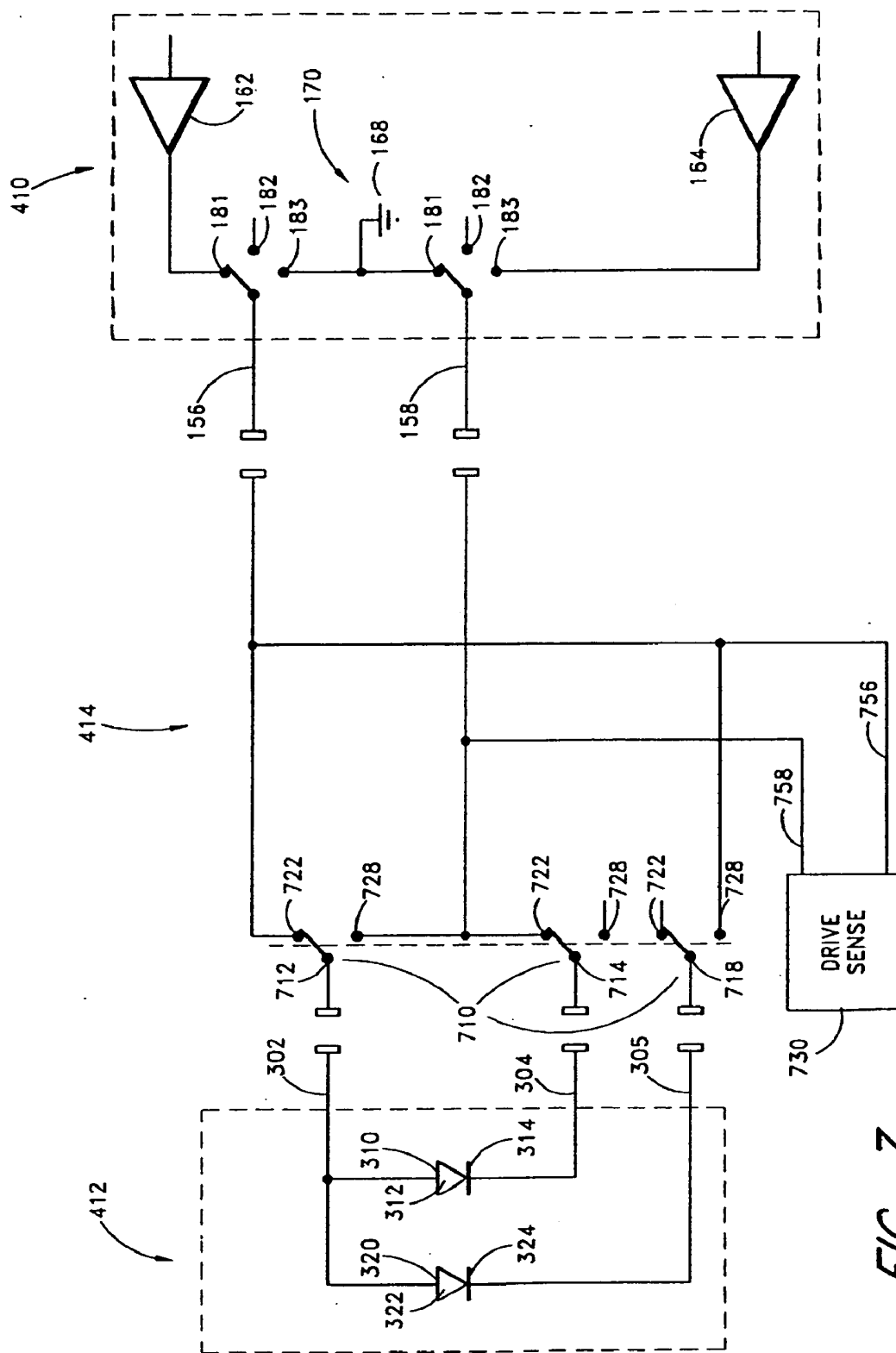

FIG. 7

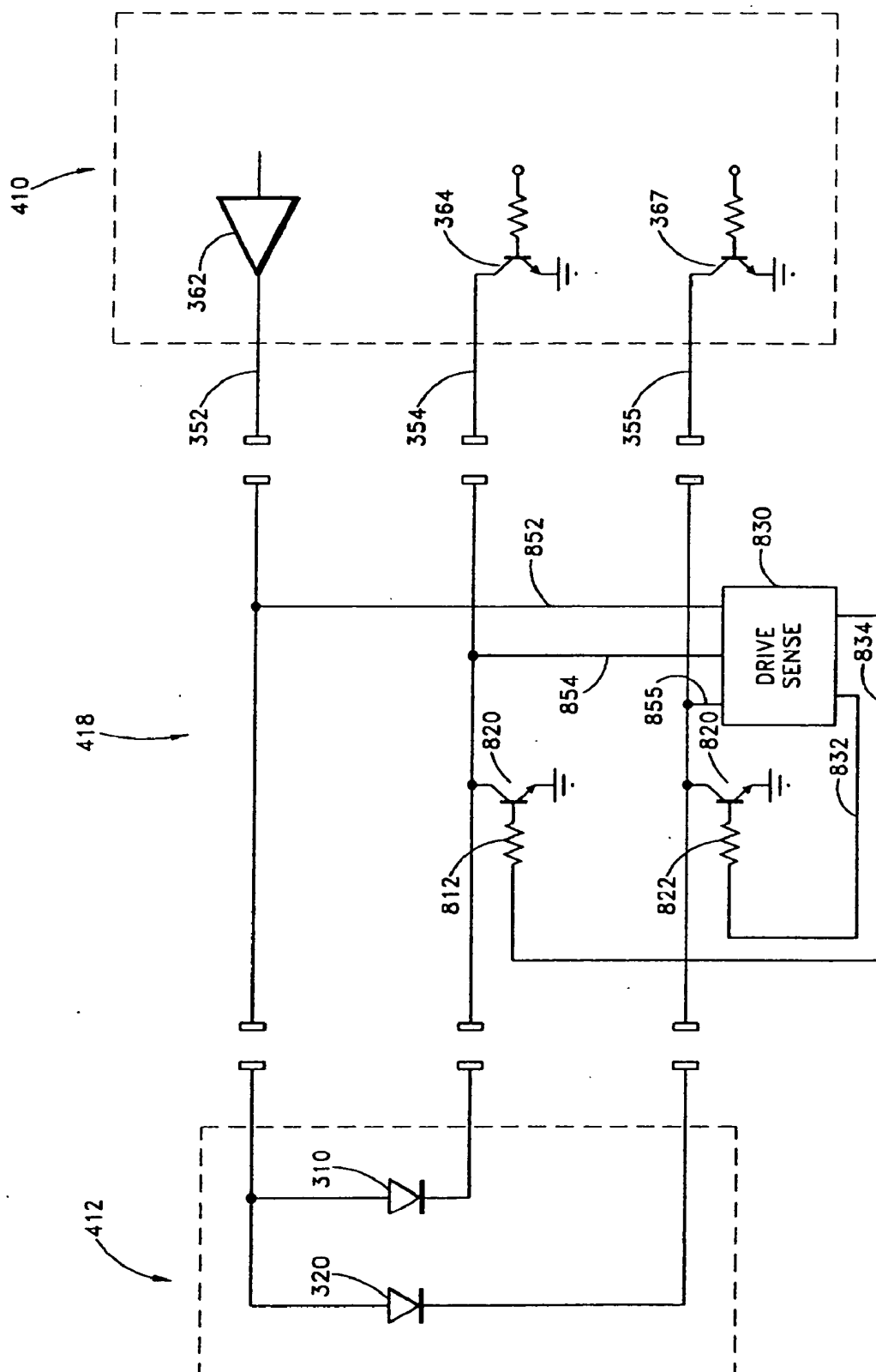

FIG. 8

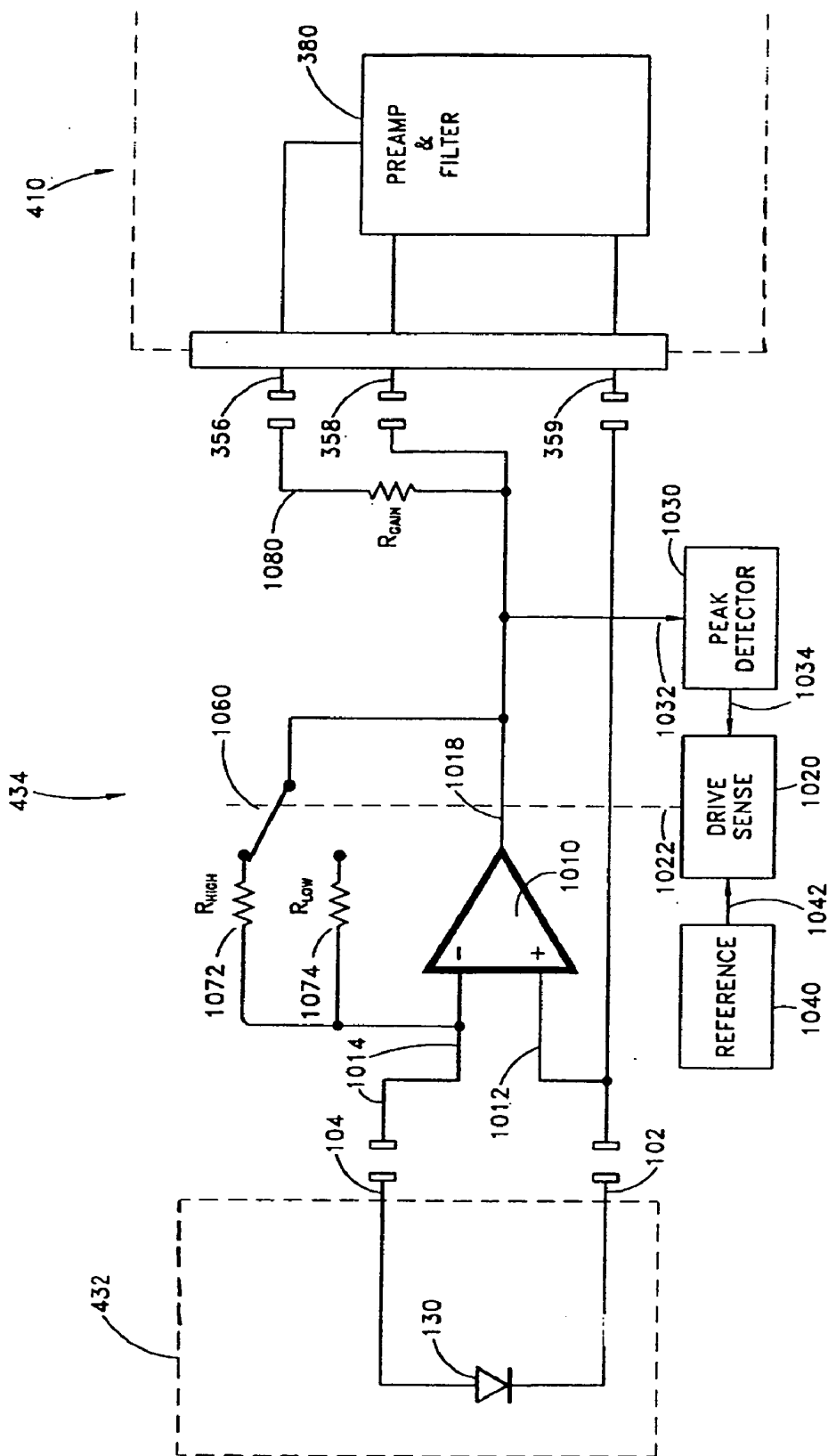

FIG. 10

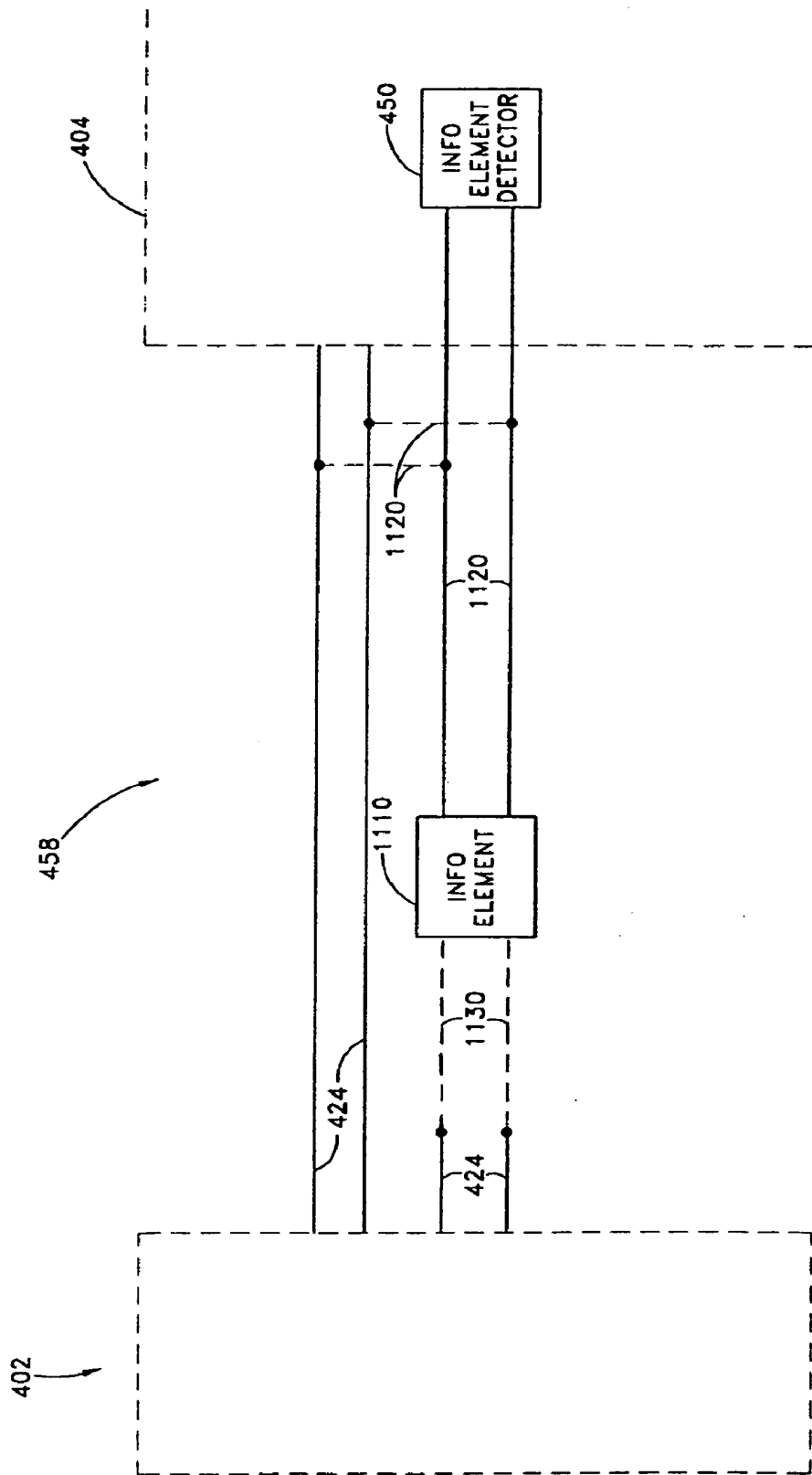

FIG. 11

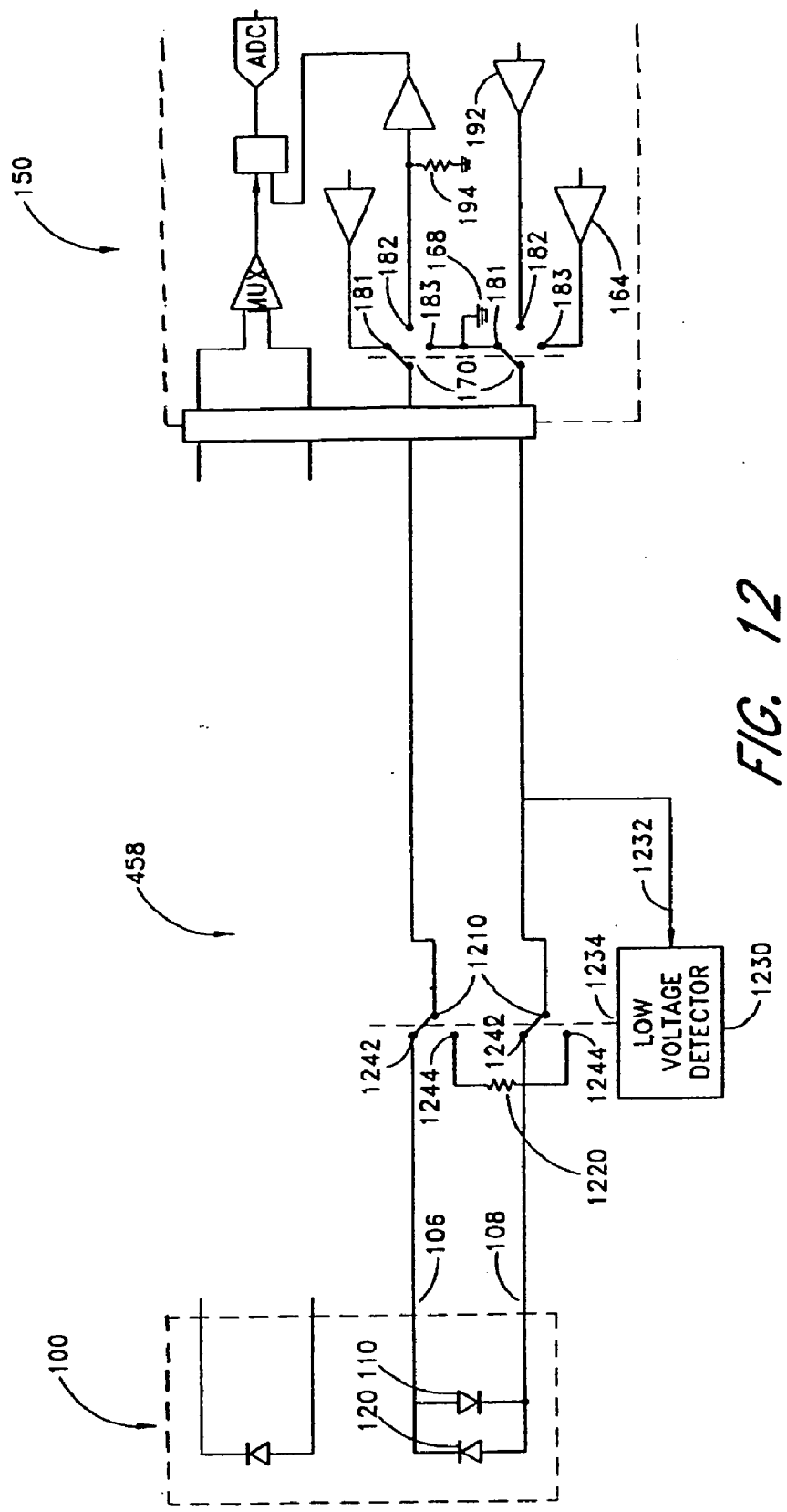

FIG. 12

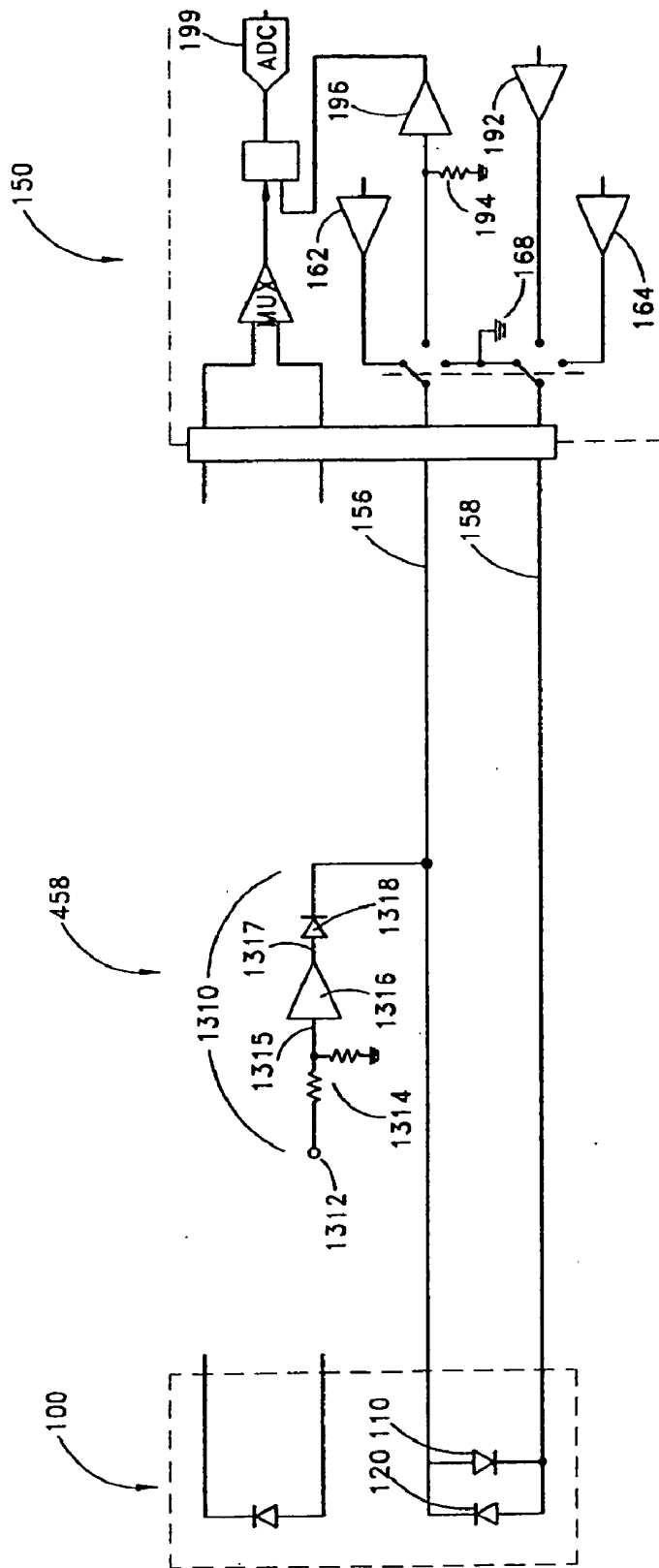

FIG. 13

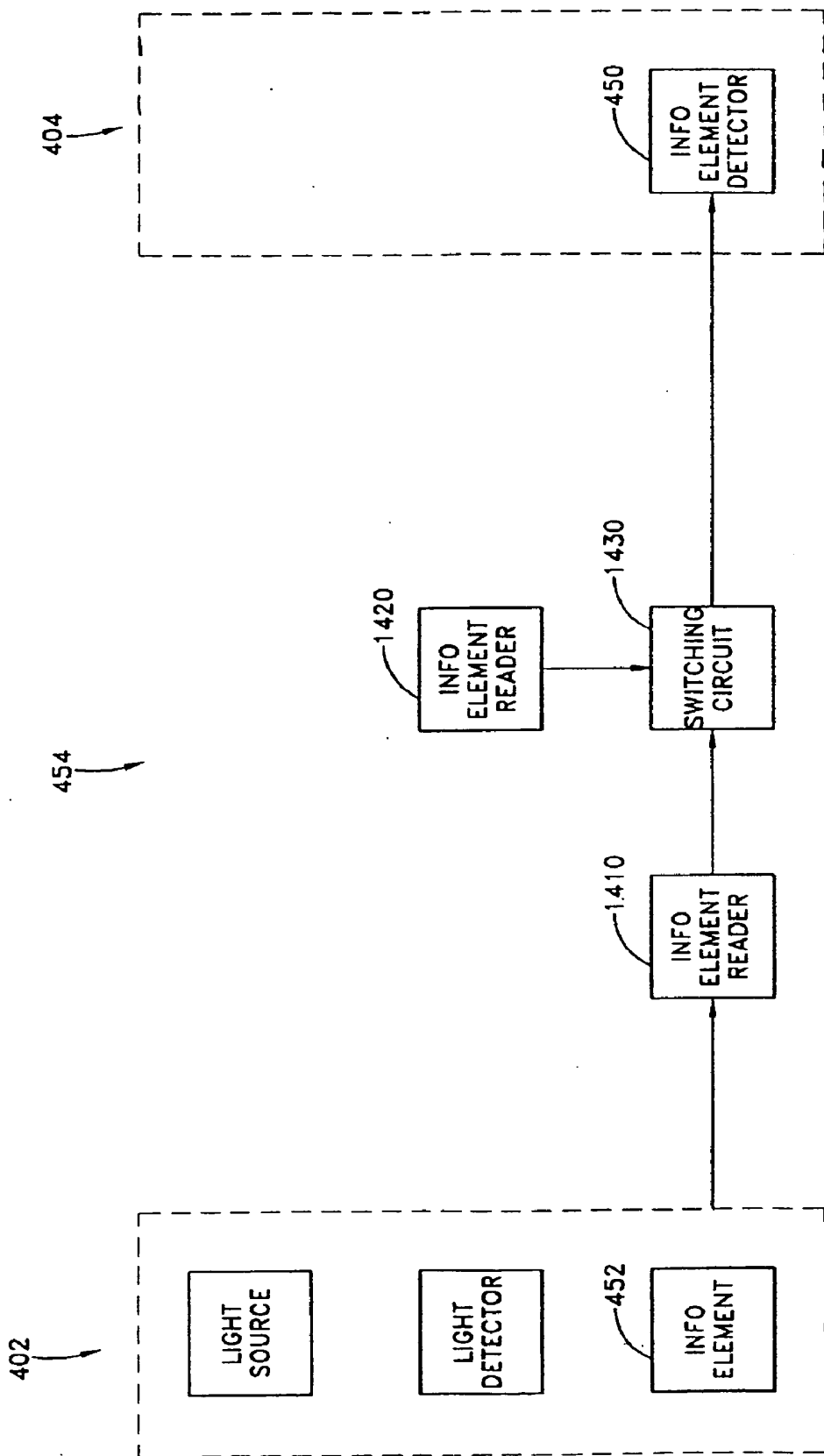

FIG. 14

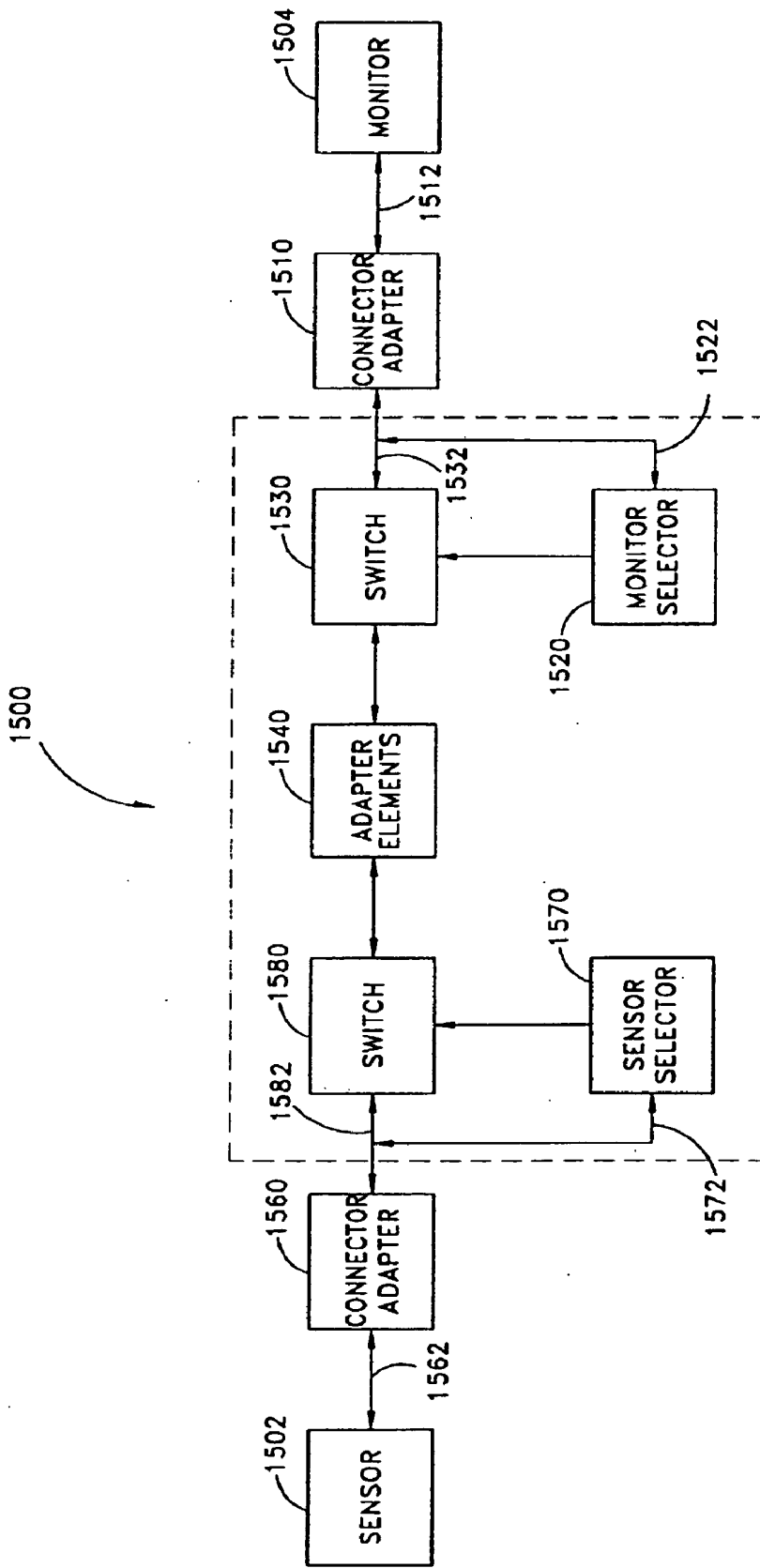
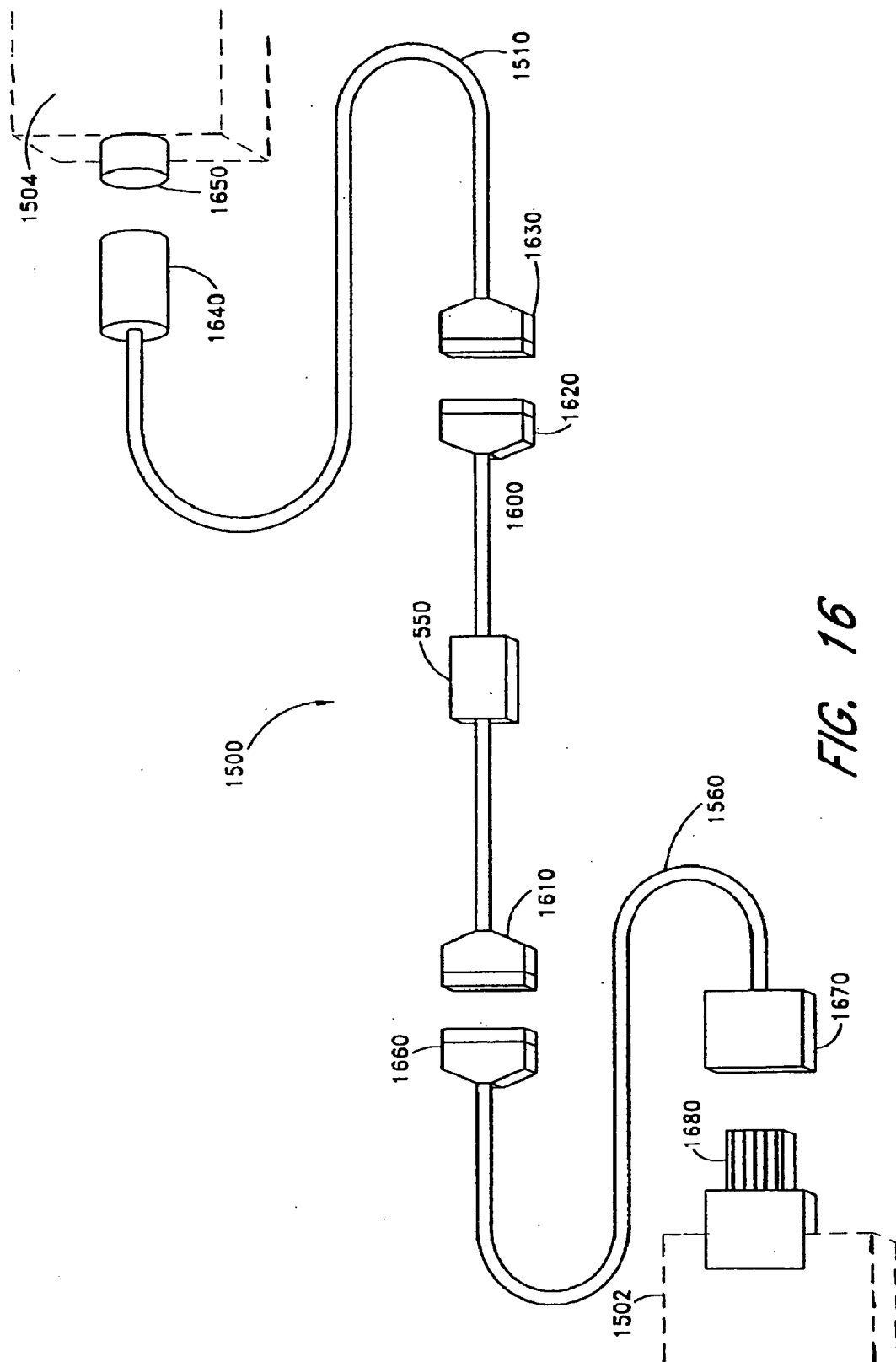

FIG. 15



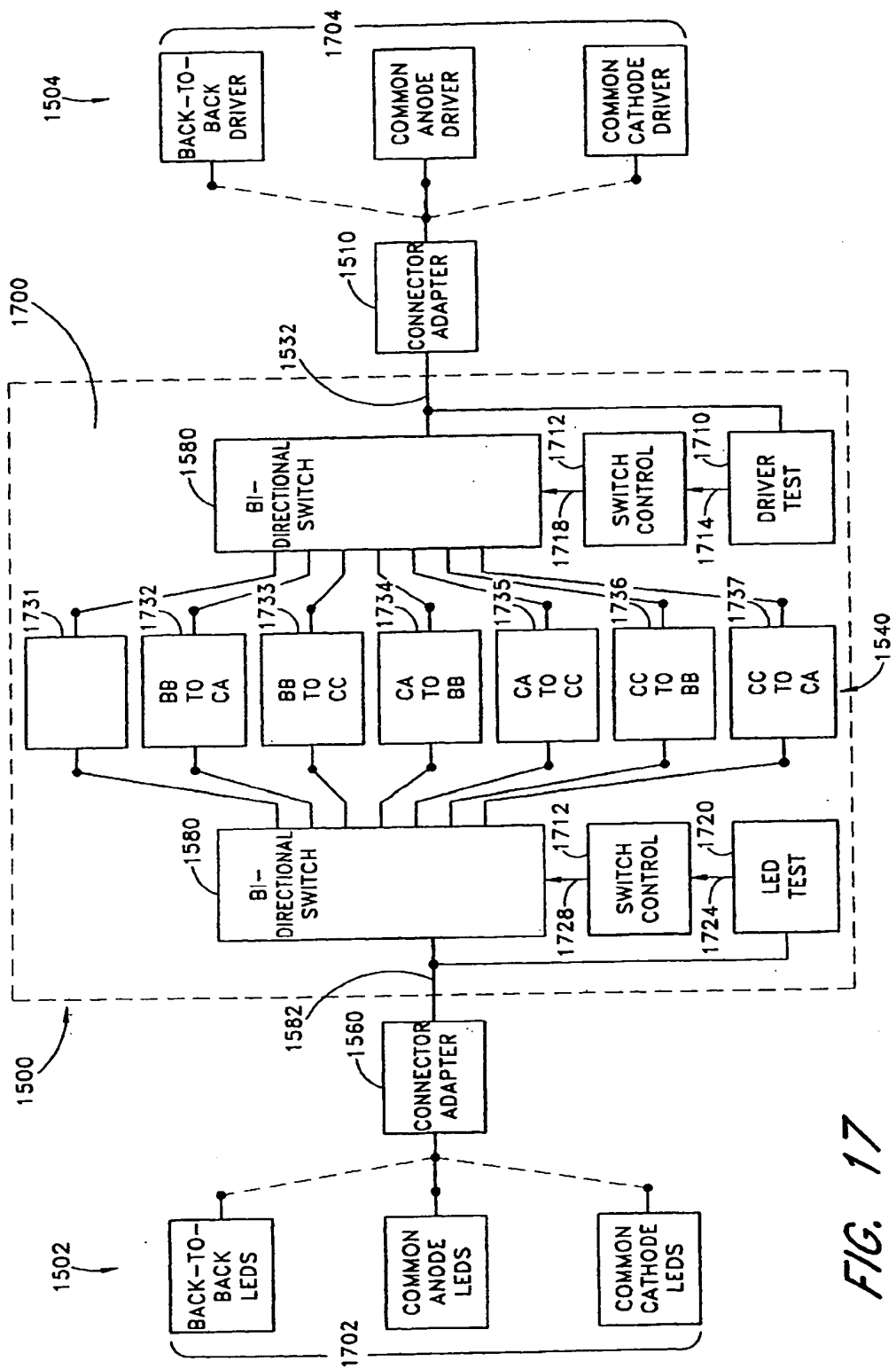

FIG. 17

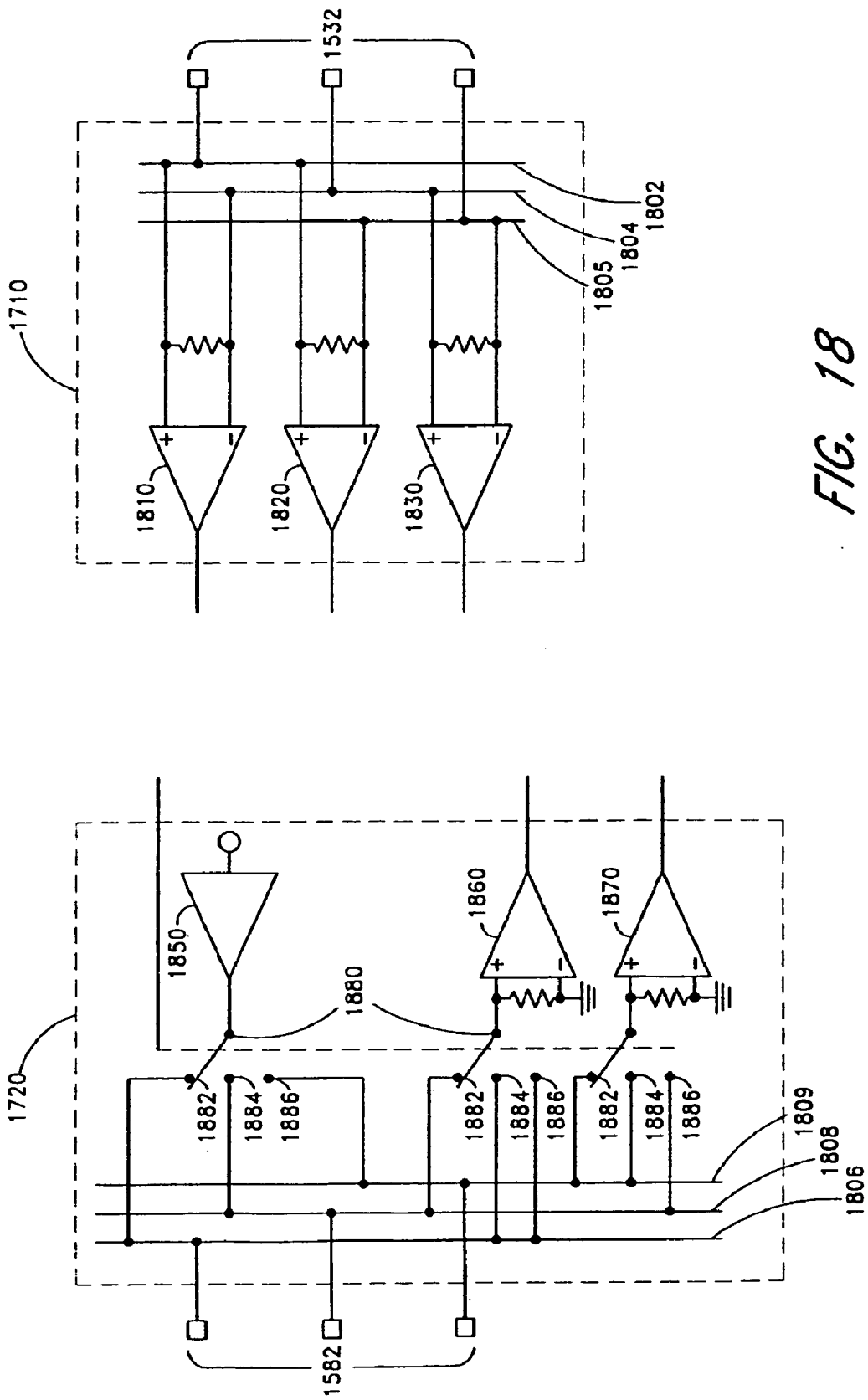

FIG. 18

PULSE OXIMETRY SENSOR ADAPTER

RELATED APPLICATION

[0001] This is a continuation application based on application Ser. No. 10/624,446, filed Jul. 22, 2003, which is a continuation of application Ser. No. 09/982,453, filed Oct. 17, 2001, now U.S. Pat. No. 6,597,933, which is a divisional of application Ser. No. 09/404,060, filed Sep. 23, 1999, now U.S. Pat. No. 6,349,228, which is a continuation of application Ser. No. 09/021,957, filed on Feb. 11, 1998, now U.S. Pat. No. 5,995,855, the entirety of which is incorporated herein by reference.

BACKGROUND OF THE INVENTION

[0002] Oximetry is the measurement of the oxygen status of blood. Early detection of low blood oxygen is critical in the medical field, for example in critical care and surgical applications, because an insufficient supply of oxygen can result in brain damage and death in a matter of minutes. Pulse oximetry is a widely accepted noninvasive procedure for measuring the oxygen saturation level of arterial blood, an indicator of oxygen supply. A pulse oximetry system consists of a sensor attached to a patient, a monitor, and a cable connecting the sensor and monitor.

[0003] Conventionally, a pulse oximetry sensor has both red and infrared LED emitters and a photodiode detector. The sensor is typically attached to an adult patient's finger or an infant patient's foot. For a finger, the sensor is configured so that the emitters project light through the fingernail and into the blood vessels and capillaries underneath. The photodiode is positioned at the finger tip opposite the fingernail so as to detect the LED emitted light as it emerges from the finger tissues.

[0004] The pulse oximetry monitor determines oxygen saturation by computing the differential absorption by arterial blood of the two wavelengths emitted by the sensor. The monitor alternately activates the sensor LED emitters and reads the resulting current generated by the photodiode detector. This current is proportional to the intensity of the detected light. A ratio of detected red and infrared intensities is calculated by the monitor, and an arterial oxygen saturation value is empirically determined based on the ratio obtained. The monitor contains circuitry for controlling the sensor, processing sensor signals and displaying a patient's oxygen saturation, heart rate and plethysmographic waveform. A pulse oximetry monitor is described in U.S. Pat. No. 5,632,272 assigned to the assignee of the present invention.

[0005] The patient cable provides conductors between a first connector at one end, which mates to the sensor, and a second connector at the other end which mates to the monitor. The conductors relay the drive currents from the monitor to the sensor emitters and the photodiode detector signals from the sensor to the monitor.

SUMMARY OF THE INVENTION

[0006] A drawback to conventional pulse oximetry systems is the lack of standardization of the sensor and the monitor. Unless the sensor and the monitor are manufactured by the same company, it is unlikely that these two components can be connected as a functioning pulse oximetry system. This incompatibility is mainly due to physical

configuration and signal parameter differences among both the sensors and the monitors. Sensors differ primarily with respect to the configuration, drive requirements and wavelength of the LEDs. Sensors also differ in the configuration and value of coding and calibration resistors used to identify, for example, sensor type or LED wavelength. Monitors differ primarily with respect to the configuration and current limit of the LED driver; the amount of preamplifier gain applied to the photodiode detector signal; and the method of reading and interpreting sensor coding and calibration resistors. Further, the physical interface between sensors and monitors, such as connector types and pinouts, is also variable. Sensor and monitor variations among various pulse oximetry systems are discussed in detail below with respect to **FIGS. 1 through 3**.

[0007] **FIG. 1** depicts one type of sensor **100** and a corresponding monitor **150** for one type of pulse oximetry system. For this particular sensor **100**, the red LED **110** and infrared LED **120** are connected back-to-back and in parallel. That is, the anode **112** of the red LED **110** is connected to the cathode **124** of the infrared LED **120** and the anode **122** of the infrared LED **120** is connected to the cathode **114** of the red LED **110**. Also for this sensor **100**, the photodiode detector **130** is configured so that the photodiode leads **102**, **104** are not in common with either of the LED leads **106**, **108**.

[0008] As shown in **FIG. 1**, the sensor **100** is also configured with a coding resistor **140** in parallel with the LEDs **110**, **120**. The coding resistor **140** is provided as an indicator that can be read by the monitor **150**, as described in pending U.S. patent application Ser. No. 08/478,493, filed Jun. 7, 1995 and assigned to the assignee of the present application. The resistor **140** is used, for example, to indicate the type of sensor **100**. In other words, the value of the coding resistor **140** can be selected to indicate that the sensor **100** is an adult probe, a pediatric probe, a neonatal probe, a disposable probe or a reusable probe. The coding resistor **140** is also utilized for security purposes. In other words, the value of the coding resistor **140** is used to indicate that the sensor **100** is from an authorized sensor supplier. This permits control over safety and performance concerns which arise with unauthorized sensors. In addition, the coding resistor **140** is used to indicate physical characteristics of the sensor **100**, such as the wavelengths of the LEDs **110**, **120**.

[0009] Also shown in **FIG. 1** is a portion of a monitor **150** that is compatible with the sensor described above. The monitor **150** has drive circuitry that includes a pair of current drivers **162**, **164** and a switching circuit **170**. The monitor **150** also has a signal conditioner, which includes an input buffer **195** that conditions the output of the sensor photodiode **130**. In addition, the monitor has a low-voltage source **164** and corresponding reference resistor **194** that read the sensor coding resistor **140**.

[0010] Each current driver **162**, **164** provides one of the LEDs **110**, **120** with a predetermined activation current as controlled by the switching circuit **170**. The switching circuit **170**, functionally, is a double-pole, triple throw (2P3T) switch. A first switch **172** connects to a first LED lead **106** and a second switch **174** connects to a second LED lead **108**. The first switch **172** has a first position **181** connected to the red LED driver **162**; a second position **182** connected to a reference resistor **194** and a buffer **195**; and

a third position 183 connected to ground 168. The second switch 174 has a first position 181 connected to ground 168; a second position 182 connected to a low-voltage source 192; and a third position 183 connected to the infrared LED driver 164.

[0011] During a particular time interval, the switching circuit 170 causes the first switch 172 to connect the red LED driver 162 to the red LED anode 112 and simultaneously causes the second switch 174 to connect the ground 168 to the red LED cathode 114. As a result, a forward current is established in the red LED 110, which is activated to emit light. During another particular time interval, the switching circuit 170 causes the first switch 172 to connect the ground 168 to the infrared LED cathode 124 and simultaneously causes the second switch 174 to connect the infrared LED driver 164 to the infrared LED anode 122. As a result, a forward current is established in the infrared LED, which is activated to emit light. This cycle is repeated to cause the sensor to alternately emit red and infrared light. These alternating light pulses result in currents in the photodiode detector 130, which are input to a monitor buffer 166 and multiplexed 197 into an analog-to-digital converter (ADC) 199. The digitized outputs from the ADC 199, representing detected intensities, are then processed by the monitor 150 and displayed as oxygen status.

[0012] During a monitor initialization interval, the switching circuit 170 causes the first and second switches 172, 174 to be in a second position 182. This isolates the LED leads 106, 108 from the drivers 162, 164 and ground 168. Further, the low-voltage source 192 is connected to one LED lead 108 and the reference resistor 194 is connected to the other LED lead 106. As a result, a voltage is established across the parallel combination of the coding resistor 140 and the LEDs 110, 120. If this voltage is less than the forward voltage of the forward biased infrared LED 120, then, because the red LED 110 is reverse biased, neither LED 110, 120 conducts significant current. In such a scenario, the current that passes through the parallel combination of the red LED 110, infrared LED 120, and coding resistor 140 is approximately equal to the current through the coding resistor 140. Thus, the equivalent circuit is the low-voltage source 192 across the series combination of the coding resistor 140 and the reference resistor 194. The resistance of the coding resistor 140 is then easily determined via Ohm's Law from the voltage across the reference resistor 194, which is read as a digitized value from the ADC 199.

[0013] FIG. 2 depicts another type of sensor 200 and corresponding monitor 250 for a conventional pulse oximetry system. This pulse oximetry system is described in U.S. Pat. No. 4,621,643 to New Jr. et al., issued Nov. 11, 1986. The sensor 200 of FIG. 2 is similar to that of FIG. 1 in that it comprises a red LED 210 and an infrared LED 220. However, in this sensor 200, the LEDs 210, 220 are in a common cathode, three-wire configuration. That is, the cathode 214 of the red LED 210 is connected to the cathode 224 of the infrared LED 220 and a common input lead 208. Also, the anode 212 of the red LED 210 and the anode 222 of the infrared LED 220 have separate input leads 202, 204. The photodiode detector 230 shown in FIG. 2 functions in much the same way as the detector 130 shown in FIG. 1 but shares one input lead 208 with the sensor LEDs 210, 220. As shown in FIG. 2, the sensor 200 also has a calibration resistor 240 with one separate input lead 206 and one lead

208 in common with the LEDs 210, 220 and photodiode 230. This resistor 240 is encoded to correspond to the measured wavelength combination of the red LED 210 and infrared LED 220.

[0014] Also shown in FIG. 2 is a portion of a monitor 250 that is compatible with the depicted sensor 200. The monitor 250 has LED drive circuitry 260 which activates the LEDs 210, 220 one at a time with a predetermined drive current independently applied to each of the LED anodes 212, 222. The monitor 250 also has a signal conditioner, including amplification and filtration circuitry 270 that conditions the input current from the detector 230, which is multiplexed 282 into a successive-approximation analog-to-digital converter (ADC) 284 comprising a comparator 285 and digital-to-analog converter (DAC) 286. A microprocessor 288 then reads the digitized detector signal for analysis. The monitor 250 reads the calibration resistor 240 by passing a predetermined current from a current source 290 through the resistor 240. The microprocessor 288 reads the resulting voltage across the resistor 240, which is passed through the multiplexer 282 and ADC 284. The microprocessor 288 then computes the resistor value per Ohm's Law.

[0015] FIG. 3 illustrates yet another type of sensor 300 and corresponding monitor 350. This configuration is similar to those of FIGS. 1 and 2 in that the sensor 300 has a red LED 310, an infrared LED 320 and a photodiode detector 330. The configuration of the LEDs 310, 320 and the corresponding LED driver 360, however, differ from those previously described. The LED driver 360 has a voltage source 362, a red LED current sink 364 and an infrared LED current sink 367. The LEDs 310, 320 are arranged in a three-wire, common-anode configuration. That is, the red LED anode 312 and the infrared LED anode 322 have a common anode lead 302, the red LED cathode 314 has one separate lead 304 and the infrared LED cathode 324 has another separate lead 305. The voltage source output 352 connects to the common anode lead 302, the red LED current sink input 354 connects to the red LED cathode lead 304, and the infrared LED current sink input 355 connects to the infrared LED cathode lead 305.

[0016] The current sinks 364, 367 control the drive current through each LED 310, 320. The voltage source 362 has sufficient output capability to supply this drive current to each LED 310, 320 individually. Each current sink 364, 367 is a grounded emitter transistor 365, 368 having a bias resistor 366, 369 and a base control input 372, 374 that switches each transistor 365, 368 on and off. The bias resistor value and voltage of the base control input determine the amount of LED drive current. In operation, the red and infrared LEDs 310, 320 are alternately activated by pulsed control signals alternately applied to the base control inputs 372, 374.

[0017] The detector portion of the sensor 300 of FIG. 3 also differs from those in the previously miniature described sensors in that a gain resistor 340 is connected to the photodiode 330. When connected to the corresponding monitor 350, the gain resistor 340 provides feedback, which adjusts the gain of a monitor preamplifier within the signal conditioner portion 380 of the monitor 350, which reduces the preamplifier dynamic range requirements. For example, if the sensor 300 is configured for neo-natal patients, where the sensor site is of relatively narrow thickness and the skin

relatively transparent, the gain can be correspondingly low. However, if the sensor 300 is configured for adult patients, with a relatively thick and opaque sensor site, such as a finger, the gain can be correspondingly higher to compensate for lower detected intensities.

[0018] FIGS. 1 through 3 are examples of just some of the functional variations between sensors and monitors in pulse oximetry systems. These functional variations thwart the use of different sensors on different monitors. There are other sensor and monitor variations not described above. For example, a sensor may have LEDs with a three-wire common-anode configuration, as depicted in FIG. 7 below. There are also other potential mismatches between sensors and monitors. For example, the LED drive current supplied by a particular monitor may be either too high or too low for the LEDs on an incompatible sensor.

[0019] Besides the functional variations described above, physical variations between sensors and monitors may prevent interconnection to form a pulse oximetry system. For example, sensors have a variety of connectors. These connectors may vary from subminiature D-type connectors to flex-circuit edge connectors to name a few. Similar connector variations exist on the monitor. Further, some pulse oximetry systems require a separate patient cable, which mates to the sensor at one end and the monitor at the other end to span the distance between patient and monitor. In other systems, the sensor incorporates a cable that plugs directly into a monitor. Another physical variation is the pinouts at both the sensor connector and monitor connector. That is, there are potential differences between what signals are assigned to what connector pins.

[0020] A conventional adapter cable can sometimes be used to interconnect two dissimilar devices. The connector at one end of the adapter cable is configured to mate with one device and the connector at the other end of the cable is configured to mate with the second device. The cable wires can be cross-connected as necessary to account for pinout differences. A conventional adapter cable, however, is of little use in interconnecting various sensors to various pulse oximetry monitors. As described above, although the sensors have similar components that perform similar functions, the incompatibilities are more than connector and pinout related. In particular, a conventional adapter cable is incapable of correcting for the signal mismatches between sensors and monitors.

[0021] Although it is perhaps possible to design sensors that accommodate a variety of monitors, such sensors would be, for the most part, commercially impractical. For one, pulse oximetry sensors can be either reusable or disposable. In the case of disposable sensors, cost per sensor is critical. Even for reusable sensors, cost and complexity are important design factors. A universal sensor having integrated adapter components could be significantly more expensive than the sensors described in FIGS. 1 through 3. A sensor adapter according to the present invention solves many of the problems associated with both sensor and monitor compatibility and the need to avoid sensor complexity.

[0022] One aspect of the present invention is an adapter that provides an interconnection between a pulse oximetry sensor and a monitor. The sensor has a light source and a light detector, and the monitor has a driver and a signal conditioner. The adapter comprises a plurality of signal

paths. The signal paths are detachably connected to either the monitor, the sensor or both. A first signal path is in communication with the driver and the light source. A second signal path is in communication with the light detector and the signal conditioner. The adapter also comprises an adapter element that is connected to at least one of the signal paths. The adapter element modifies a characteristic of at least one of the signal paths so that the sensor and the monitor are jointly operable to measure oxygen status. In one embodiment, where the monitor has an information element detector in communication with at least one of the signal paths, the adapter element conveys information about the sensor that is compatible with the information element detector. In another embodiment, the adapter element is connected to the first signal path and matches the light source configuration with the driver configuration. In yet another embodiment, the adapter element is connected to the first signal path and matches the drive requirements of the light source with the drive capabilities of the driver. In an additional embodiment, the adapter element is connected to the second signal path and provides gain for a detector signal.

[0023] Another aspect of the present invention is a sensor adapter comprising a sensor having a light source and a light detector and comprising a plurality of signal paths. The signal paths are detachably connected to a monitor. A first signal path communicates a drive signal from the monitor to the light source. A second signal path communicates an intensity signal from the light detector to the monitor. The sensor adapter also comprises an adapter element in communication with at least one of the signal paths. The adapter element creates a compatibility signal that allows the sensor and the monitor to be jointly operable as a pulse oximetry system. In one embodiment, the sensor adapter comprises an active component. The active component generates a predetermined signal level applied to the first signal path that conveys information regarding a compatible sensor. In another embodiment of the sensor adapter, the light source has a conductive portion with a predetermined equivalent resistance that conveys information regarding a compatible sensor. Advantageously, the conductive portion may be an LED encapsulant or incorporated within the semiconductor material of an LED. In yet another embodiment, the sensor adapter further comprises a translator that senses a sensor information element and communicates equivalent information to the monitor.

[0024] Yet another aspect of the present invention is a method of connecting an incompatible sensor to a monitor. The method comprises the step of adapting a signal in communication with either the sensor, the monitor or both so that the sensor and the monitor are jointly operable as a pulse oximetry system. In one embodiment, the adapting step comprises the steps of sensing a drive signal and switching the drive signal to a particular one of a plurality of light source leads in response to the drive signal. Advantageously, the switching step may connect a two-wire driver to a three-wire light source or may connect a three-wire driver to a two-wire light source, either connection being made through a multiple-pole, multiple-throw switch. In another embodiment, the adapting step comprises adjusting a drive signal from the monitor to match the drive requirements of a light source in the sensor. In yet another embodiment, the adapting step comprises providing a feedback signal to the monitor. The amount of the feedback determines the gain

applied within the monitor to a light detector signal from the sensor. In an additional embodiment, the adapting step comprises generating an information signal to an information element detector that corresponds to information from a compatible sensor. In another embodiment, the adapting step comprises translating an information signal from a sensor into a translated information signal that is read by an information element detector and corresponds to a compatible sensor.

[0025] A further aspect of the present invention is a sensor adapter for operably interconnecting an incompatible sensor to a monitor in a pulse oximetry system comprising an interconnect means for providing a signal path between the sensor and the monitor. The sensor adapter also comprises an adapter means for creating a compatible signal on the signal path. In one embodiment, the adapter means comprises a configuration means for routing a drive signal from the monitor so as to correspond to a light source in the sensor. In another embodiment, the adapter means comprises a limit means for changing the amount of a drive signal from the monitor so as to correspond to a light source in the sensor. In yet another embodiment, the adapter means comprises a gain means for modifying the amplitude of a detector signal from the sensor. In an additional embodiment, the adapter means comprises an information means for providing a signal to an information element detector that corresponds to a compatible sensor.

BRIEF DESCRIPTION OF THE DRAWINGS

[0026] The present invention is described in detail below in connection with the following drawing figures in which:

[0027] **FIG. 1** is a schematic diagram representing a sensor and corresponding monitor interface circuitry;

[0028] **FIG. 2** is a schematic diagram representing another prior art sensor and corresponding monitor interface circuitry;

[0029] **FIG. 3** is a schematic diagram representing yet another prior art sensor and corresponding monitor interface circuitry;

[0030] **FIG. 4** is a block diagram of a sensor adapter according to the present invention;

[0031] **FIG. 5** is an illustration of various physical embodiments of a sensor adapter in relation to a sensor and a monitor;

[0032] **FIG. 6** is a block diagram of a drive configuration adapter portion of the sensor adapter for a monitor with three-wire, common-anode drivers to a sensor with two-wire, back-to-back LEDs;

[0033] **FIG. 7** is a block diagram of a drive configuration adapter portion of the sensor adapter for a monitor with two-wire, back-to-back LED drivers to a sensor with three-wire, common-anode LEDs;

[0034] **FIG. 8** is a block diagram of a drive limit adapter portion of the sensor adapter illustrating a drive current gain;

[0035] **FIG. 9** is a block diagram of a drive limit adapter portion of the sensor adapter illustrating a drive current reduction;

[0036] **FIG. 10** is a block diagram illustrating the active gain adapter portion of the sensor adapter;

[0037] **FIG. 11** is a schematic of an embodiment of the information generator adapter portion of the sensor adapter featuring an adapter information element;

[0038] **FIG. 12** is a schematic of another embodiment of the information generator adapter portion of the sensor adapter;

[0039] **FIG. 13** is a schematic of yet another embodiment of the information generator adapter portion of the sensor adapter;

[0040] **FIG. 14** is a schematic diagram of the information translation adapter portion of the sensor adapter;

[0041] **FIG. 15** is a block diagram of a universal sensor adapter embodiment of the sensor adapter;

[0042] **FIG. 16** is an illustration of a universal adapter cable embodiment of the universal sensor adapter;

[0043] **FIG. 17** is a block diagram of the configuration adapter portion of the universal sensor adapter; and

[0044] **FIG. 18** is a schematic diagram of the driver test and sensor test portions of the configuration adapter.

DETAILED DESCRIPTION OF THE PREFERRED EMBODIMENT

[0045] **FIG. 4** shows a functional block diagram of a sensor adapter **400** for interconnecting a sensor **402** to an incompatible monitor **404** in a pulse oximetry system. Interconnecting the monitor light source driver **410** with the sensor light source **412** are a light source configuration **414** adapter and a drive limit **418** adapter. The light source configuration **414** element adapts the light source driver **410** to the particular configuration of the sensor light source **412**, such as two-wire, back-to-back LEDs, three-wire, common-anode LEDs and three-wire, common-cathode LEDs. The drive limit **418** element increases or decreases the current of the light source driver **410** to adapt to the requirements of the sensor light source **412**.

[0046] Also shown in **FIG. 4** is an active gain **434** element, which adapts the sensor light detector **432** to the monitor signal conditioner **430**. Active gain **434** sets the amount of amplification of the signal from the sensor light detector **432** that occurs in the monitor signal conditioner **430**. Active gain **434** may also provide preamplification of the light detector signal before input to the monitor **404**.

[0047] **FIG. 4** further shows a monitor information element detector **450** that is interconnected with an information generator **458** and information translator **454**. The information generator **458** simulates an information element **452** on the sensor to provide the monitor information element detector **450** with information regarding, for example, sensor type, origin or light source calibration. The information translator **454** reads a sensor information element **452** and provides the equivalent information to the monitor information element detector **450**, adapting to the configuration and value expected by the monitor **404**.

[0048] As shown in **FIG. 4**, the sensor adapter **400** has a power supply **470**. As such, the functions of the sensor adapter **400** as described above can be performed with both

active and passive components. In one embodiment, the power supply 470 has an internal power source 472, such as a lithium-ion battery. In another embodiment, the power supply 470 uses an external power source. The external power source may be, for example, one or more d.c. voltages available from a monitor output 474. Alternatively, the external power source may be derived from the light source driver 410, which supplies pulsed power to the sensor light source 412. A fraction of this pulsed power can be routed by a tap 478 to the power supply 470, where it is a.c.-to-d.c. converted. Regardless of the power source, the power supply 470 may also include d.c.-to-d.c. conversion, filtering and voltage regulation to provide suitable voltage levels and power conditioning for the active components of the sensor adapter 400, as is well-known in the art.

[0049] FIG. 5 illustrates embodiments of the pulse oximetry sensor adapter according to the present invention. In one embodiment, the sensor adapter is configured as a connector block 510 that has a first connector 512 on one end that is attachable directly to a monitor 502 by plugging into a monitor connector 504 and a second connector 514 on the other end that accepts a cable connector 522. The components of the sensor adapter are mounted to a small substrate 515, and may be, for example, surface-mount devices soldered on one or both sides of a circuit board or flex-circuit. The substrate 515 is electrically interconnected to the connectors 512, 514. This interconnection may be done with conductors 516, such as individual wires, flex-circuit traces or ribbon cable soldered to both the substrate 515 and the connectors 512, 514. Alternatively, the substrate 515, might be directly attached to both connectors 512, 514. The substrate 515, conductors 516 and portions of the connectors 512, 514 are encapsulated by insulating material that forms the connector block body 518. One will recognize other possibilities for mounting and interconnecting the adapter components within the connector block 510.

[0050] FIG. 5 illustrates another embodiment of the sensor adapter where the adapter is configured as an adapter cable 520 that also serves the function and substitutes for a conventional patient cable or sensor cable. In this embodiment, the sensor adapter can be alternatively incorporated into a first end portion 530 of the cable 520, which would attach proximate to the monitor 502; a second end portion 540 of the cable 520, which would attach proximate to the sensor 506; or the cable body 522, as, for example, an attached molded cable block 550. Whether incorporated into the first end portion 530, second end portion 540 or the cable body 522, the adapter components are mounted to a substrate 515, as described.

[0051] If the sensor adapter is incorporated into the first end portion 530 or the second end portion 540, the substrate 515 with the adapter components is interconnected between the cable connector 522, 542 and the wiring within the cable body 522. If the sensor adapter is incorporated into the cable body 522, the substrate 515 is interconnected with the wiring within the cable body 522. Regardless, the substrate 515 is interconnected as described above with respect to the connector block 510. The substrate 515, connector 522, 542 and interconnection are then encapsulated to form a connector body 532, 542 or cable block body 552, also as described above.

[0052] As shown in FIG. 5, the sensor adapter may also be incorporated into the sensor 506. This, however, increases

the cost of the sensor, which may be particularly critical for disposable sensors. For this embodiment, the adapter components can be mounted on a substrate 515, as described above. In turn, the substrate 515 can be mounted to the sensor 506, for example, by attaching and electrically interconnecting the substrate 515 to a flex circuit portion of the sensor 506. Alternatively, the adapter components can be mounted directly to the flex circuit portion of the sensor 506 or incorporated within particular sensor components, as with a conductive LED layer or encapsulant to form a coding or calibration resistor, as described below.

[0053] FIG. 6 shows an embodiment of the light source configuration portion 414 of the sensor adapter. The light source portion 412 of the sensor is shown with a red LED 110 and infrared LED 120 in a back-to-back configuration. The light source driver portion 410 of the monitor is shown with a voltage source 362 and two current sinks 364, 367. This driver was described above with respect to FIG. 3 in connection with a common-anode LED sensor. Thus, the embodiment of the light source configuration element 414 shown in FIG. 6 adapts a three-wire common-anode driver to a two-wire, back-to-back LED light source. The discussion below is equally applicable to a sensor where the positions of the red LED 110 and the infrared LED 120 are swapped and, correspondingly, that of the red LED current sink 364 and infrared LED current sink 367 are swapped from that shown in FIG. 6.

[0054] As shown in FIG. 6, the adapter 414 has a double-pole, double-throw (DPDT) switch 610. A first switch pole 612 is connected to a first lead 106 of the sensor LEDs 110, 120. A second switch pole 614 is connected to a second lead 108 of the sensor LEDs 110, 120. In a first position 616 (depicted), the switch 610 connects the red LED anode 112 to the voltage source 362 and the red LED cathode 114 to the red LED current sink 364. In a second position 618 (not depicted), the switch 610 connects the infrared LED anode 122 to the voltage source 362 and the infrared LED cathode 124 to the infrared LED current sink 367. In this manner, the voltage source 362 is alternately switched between LED anodes 112, 122 and the appropriate current sink 364, 367 is alternately switched to the appropriate LED cathode 114, 124, alternately activating each of the LEDs 110, 120.

[0055] As illustrated in FIG. 6, the adapter also has a drive sense 620 that controls the switch 610. The drive sense 620 has a tap 652, 654, 655 on each of the monitor driver leads 352, 354, 355, which allows the drive sense 620 to determine which of the current sink transistors 365, 368 is biased to a conducting state. The drive sense 620 then sets the switch position accordingly. One will recognize many ways to implement the drive sense 620. For example, the output of a differential amplifier could control the switch 610, where the amplifier input is a resistor connected between the voltage source 362 and the red LED current sink 364. The amplifier could detect the voltage drop as current flows in the resistor when the red LED current sink 364 is in a conducting state, and actuate the switch 610 to the first position accordingly. When no voltage drop is detected, the switch 610 would return to the second position.

[0056] The switch 610 is implemented with active components, such as multiple FET transistors connected in a DPDT configuration and having a control voltage applied to the FET gates to control conduction through the FET chan-

nels, as is well-known in the art. One will also recognize that a number of FET transistor configurations are equivalent to the DPDT configuration shown in FIG. 6.

[0057] FIG. 7 shows another embodiment of the light source configuration portion 414 of the sensor adapter. The light source portion 412 of the sensor is shown with a red LED 310 and infrared LED 320 in a three-wire, common-anode configuration. The light source driver portion 410 of the monitor is shown with two drivers 162, 164 and a DPDT switch 170. This driver was described above with respect to FIG. 1 in connection with a back-to-back LED sensor. Thus, the embodiment of the light source configuration element 414 shown in FIG. 7 adapts a two-wire, back-to-back LED driver 410 with a three-wire, common-anode LED light source 412.

[0058] As shown in FIG. 7, the adapter has a triple-pole, double-throw (3PDT) switch 710. A first switch pole 712 is connected to a first lead 302 of the sensor LEDs 310, 320. A second switch pole 714 is connected to a second lead 304 of the LEDs 310, 320. A third switch pole 718 is connected to a third lead 305 of the LEDs 310, 320. The adapter switch first position 722 corresponds to the driver switch first position 181, as depicted in FIG. 7. The adapter switch second position 728 corresponds to the driver switch third position 183. When the driver switch 170 is in the second position 182, the adapter switch 710 can be in either position 722, 728. In the first position 722, the adapter switch 710 connects the red LED anode 312 to a first monitor lead 156, when that lead 156 is connected to the red LED current source 162. In this first position 722, the switch 710 also connects the red LED cathode 314 to a second monitor lead 158, when that lead 158 is connected to ground 168. In this first position 722, the infrared LED cathode 324 is disconnected. In a second position 728, the adapter switch 710 connects the infrared LED anode 322 to the monitor second lead 158, when that lead 158 is connected to the infrared LED current source 164. In this second position 728, the adapter switch 710 also connects the infrared LED cathode 324 to the first monitor lead 156, when that lead 156 is connected to ground 168. In this second position 728, the red LED cathode 314 is disconnected. In this manner, the red LED current source 162 is driving the red LED 310 alternately as the infrared LED current source 164 is driving the infrared LED 320.

[0059] As illustrated in FIG. 7, the light source configuration portion 414 of the sensor adapter also has a drive sense 730 that controls the positions of the adapter switch 710. The drive sense 730 has a tap 756, 758 on each of the driver leads 156, 158 that allow the drive sense 730 to determine the position of the driver switch 170. The drive sense 730 then sets the sensor switch position accordingly. One will recognize many ways to implement the drive sense 730. For example, a differential amplifier could detect the polarity of the taps 756, 758, the amplifier output controlling the positions of the adapter switch 710. For example, the amplifier could detect that the polarity of the first monitor lead 156 is positive with respect to the second monitor lead 158, indicating the driver switch 170 is in the first position 181. The amplifier output would then actuate the adapter switch 710 to the first position 722. As discussed above with respect to FIG. 6, the switch is implemented with active components, for example, FET transistors. Also, as discussed above, one will also recognize that a number of FET

transistor configurations would be equivalent to the 3PDT configuration shown in FIG. 7.

[0060] FIG. 8 shows an embodiment of the drive limit portion 418 of the sensor adapter. In this embodiment, the drive limit adapter 418 provides increased drive current through the sensor light source 410. For purposes of illustration, the sensor light source 410 shown in FIG. 8 is a three-wire, common-anode LED configuration as described above with respect to FIG. 3. Also for purposes of illustration, the monitor light source driver 412 is configured to drive a three-wire, common-anode LED configuration, also as described above with respect to FIG. 3. It is assumed, however, that the sensor LEDs 310, 320 require an increased drive current over what the driver 412 provides. The drive limit adapter portion 418, therefore, provides an adapter red LED current sink 810 in parallel with the monitor red LED current sink 364 and an adapter infrared LED current sink 820 in parallel with the monitor infrared LED current sink 367. A drive sense 830 similar to the one described above with respect to FIG. 6 controls the adapter current sinks 810, 820. That is, the drive sense 830 has a tap 852, 854, 855 on each of the driver leads 352, 354, 355 that allow the drive sense 830 to determine which of the monitor current sinks 364, 367 are biased to a conducting state. The drive sense 830 then biases the corresponding adapter current sink 810, 820 to a conducting state. The bias resistors 812, 822 and the bias voltage applied by the drive sense control outputs 832, 834 determine the current through the adapter current sinks 810, 820. The current through the red LED 310 is the sum of the current through the corresponding adapter red LED current sink 810 and the monitor red current sink 364. Likewise, the current through the infrared LED 320 is the sum of the current through the corresponding adapter infrared LED current sink 820 and the monitor infrared current sink 367.

[0061] FIG. 9 shows another embodiment of the drive limit portion 418 of the sensor adapter. In this embodiment, the drive limit adapter 418 provides for decreased drive current through the sensor light source 410. For purposes of illustration, the sensor light source 410 and the monitor driver 412 are shown the same as described above with respect to FIG. 8. For this embodiment, however, it is assumed that the sensor LEDs 310, 320 require a reduced drive current from what the driver 412 provides. The drive limit adapter 418, therefore, provides a red LED shunt 910 and an infrared LED shunt 920. Each shunt 910, 920 allows an amount of current to bypass a particular LED 310, 320, as determined by the resistance value of the shunt 910, 920. The current through the red LED 310 is the difference between the current drawn by the red LED current sink 364 and the current bypassed through the red LED shunt 910. Likewise, the current through the infrared LED 320 is the difference between the current drawn by the infrared LED current sink 367 and the current bypassed through the infrared LED shunt 920.

[0062] FIG. 10 depicts an embodiment of the active gain portion 434 of the sensor adapter. Active gain 434 adapts the light detector portion 432 of the sensor to the signal conditioner portion 430 of the monitor. One function of the active gain adapter 434 is to provide a resistor 1080 in the feedback path 356 of a preamplifier 380, for monitors which require this feature to control dynamic range, as described above with respect to FIG. 3. The value, R_{gain} , of the resistor 1080

determines the gain of the preamplifier 380. As illustrated in FIG. 10, another function of the active gain adapter 434 is to adjust the signal level of the photodiode 130. This function also adapts the dynamic range of the monitor preamplifier 380 to a particular sensor type or application. A variable gain amplifier 1010 adjusts the detected signal level from the photodiode 130. The amplifier inputs 1012, 1014 are connected to the photodiode output leads 102, 104. The amplifier output 1018 drives the preamplifier input 358. A single-pole, double-throw (SPDT) gain switch 1060 selects one of two feedback resistors 1072, 1074. The selected resistor value, R_{high} or R_{low} , determines the amplifier gain.

[0063] The gain switch 1060 is controlled by a comparator 1020 in combination with a peak detector 1030 and a reference 1040. The peak detector 1030 has an input 1032 connected to the output 1018 of the amplifier 1010. The peak detector 1030 measures the amplified difference between detector dark current and detector signal current. This difference at the peak detector output 1034 is compared 1020 to a reference output 1042. If the peak signal level is below the reference value, the comparator output 1022 actuates the gain switch 1060 to select the high gain resistor 1072. If the peak signal level is above the reference value, the comparator output 1022 actuates the gain switch 1060 to select the low gain resistor 1074. Hysteresis or integration of the peak detector output, for example, can be used to stabilize the amplifier gain settings, as is well-known in the art. Also, one will recognize that a bank of N resistors and single-pole, N-throw switch can be used to provide multiple gain settings for the amplifier 1010, as determined by multiple reference outputs from the reference source 1040.

[0064] FIG. 11 illustrates an embodiment of the information generator portion 458 of the sensor adapter. An information element 1110 is located in the sensor adapter to substitute for an equivalent sensor information element. The information element 1110 connects via conductors 1120 to the information element detector portion 450 of the monitor 404, which senses the information content of the information element 1110. The information element 1110 may have series connections 1130 or parallel connections 1140 to outputs 424 of the sensor 402.

[0065] As an example, the sensor adapter could be an adapter cable having a coding or calibration resistor mounted as described above with respect to FIG. 5. In particular, as illustrated with the monitor 250 of FIG. 2, the adapter cable could have an information element that is a calibration resistor, which connects between the monitor leads 256, 258. Similarly, as illustrated with the monitor 150 of FIG. 1, the adapter cable could have an information element that is a coding resistor, which connects between the monitor leads 156, 158. In this manner, a sensor without a coding or calibration resistor would properly function when attached with the adapter cable to a monitor that requires such a resistor.

[0066] As illustrated in FIG. 1, an equivalent substitute for a calibration or coding resistor can also be located on the sensor itself in the form of leakage resistance built into the sensor. In one embodiment, the red LED 110 and infrared LED 120 can be encapsulated with a material having some conductance so as to form an equivalent resistance equal to the desired value of the coding resistor 140. In another embodiment, the semiconductor material of the red LED

110, the infrared LED 120 or both can be fabricated with some conductance to form an equivalent resistance equal to the desired value of the coding resistor 140.

[0067] FIG. 12 illustrates another embodiment of the information generator portion 458 of the sensor adapter. The information generator 458 has a DPDT adapter switch 1210, an adapter resistor 1220 and a low-voltage detector 1230. The adapter switch 1210 has a first position 1242 that connects the sensor LED leads 106, 108 to the monitor output leads 156, 158. The adapter switch 1210 has a second position 1244 that connects the adapter resistor 1220 across the output leads 156, 158. The low-voltage detector 1230 has an input 1232 that can be connected to the low-voltage output lead 158. The low-voltage detector 1230 has an output that controls the adapter switch 1210.

[0068] As illustrated in FIG. 12, the operation of the information generator 458 is illustrated with respect to the monitor 150, described above with respect to FIG. 1. In its first position 1242, the adapter switch 1210 connects the two leads of the sensor LEDs 106, 108 to the two monitor output leads 156, 158. The adapter switch first position 1242 corresponds to the monitor switching circuit first position 181 and third position 183, at which the LED drivers 162, 164 alternately activate the LEDs 110, 120.

[0069] As shown in FIG. 12 and described above with respect to FIG. 1, during calibration, the switching circuit 170 is set to a second position 182 which isolates the monitor output leads 156, 158 from the drivers 162, 164 and ground 168. During this calibration period, a combination of a low-voltage source 192 and a reference resistor 194 are connected to the output leads 156, 158 to determine the value of a sensor coding resistor. The low voltage detector 1230 senses the low voltage on the output leads 156 and actuates the adapter switch 1210 to its second position 1244. With the adapter switch 1210 in the second position 1244, the adapter resistor 1220 is connected between to the low-voltage source 192 and the reference resistor 194. As a result, the monitor reads the value of the adapter resistor 1220, which is a predetermined resistance equivalent to the value of a coding resistor required by the monitor 150 for proper operation. In this manner, the information generator 458 adapts a sensor 100 without a coding resistor 140 to the monitor 150.

[0070] FIG. 13 illustrates yet another embodiment of the information generator portion 458 of the sensor adapter. The information generator 458 comprises a fixed voltage source 1310 connected to the output lead 156 of the reference resistor 194. The voltage source 1310 has a bias voltage input 1312 and, bias resistors 1314, which divide the voltage between the bias voltage input 1312 and the input 1315 of the buffer amplifier 1316. The output 1317 of the amplifier 1316 is connected to the anode of an isolation diode 1318, the cathode of which is connected to the output lead 156. While the LEDs 110, 120 are driven, the isolation diode 1318 is back biased by the red LED driver 162 or by the combination of the infrared LED driver 164 and the infrared LED 120 voltage drop, effectively isolating the fixed voltage source 1310 from the output lead 156.

[0071] During the initialization interval described above, the monitor 150 is expecting to read a coding resistor of value

$$R_c = R_{ref} * [(V_{low}/V_{adc}) - 1],$$

[0072] where R_{ref} is the resistance of the monitor reference resistor 194, V_{low} is the output voltage of the low-voltage source 192 and V_{adc} is the voltage measured at the buffer input 196 and also output to the ADC 199. The LEDs 110, 120 are not conducting during the calibration period because the red LED 110 is back biased and the low-voltage source 192 provides insufficient forward voltage to the infrared LED 120 for conduction to occur. Because the sensor 100 does not have a coding resistor, the low-voltage source 192 is effectively isolated from the output lead 156 and reference resistor 194. During this period, the isolation diode 1318 is forward biased by the amplifier 1317. As a result, the voltage at the amplifier output 1317, ignoring the diode voltage drop, appears across the reference resistor 194. If the predetermined value of the voltage source is

$$V = V_{low} \cdot [R_{ref} / (R_c + R_{ref})]$$

[0073] The voltage at the buffer input 196 is the same as if the sensor had a coding resistor of value, R_c , as can be seen by substituting V for V_{adc} in the equation for R_c above. Thus, the fixed voltage source provides equivalent information to the monitor 150 as if the sensor 100 had a coding resistor. One will recognize that other voltage source configurations are possible. Further, an equivalent current source can be connected to the output lead 156 to simulate a sensor coding resistor. The predetermined value of that current source is:

$$I = V_{low} / (R_c + R_{ref})$$

[0074] This current flows through the reference resistor 194 such that the voltage read by the monitor, V_{adc} at the ADC 199, is the same as given above for the voltage source embodiment.

[0075] FIG. 14 illustrates an embodiment of the information translator portion 454 of the sensor adapter. The information translator 454 reads a sensor information element 452 and provides an equivalent value, i.e. a translated value providing the same information, to the information element detector portion 450 of a monitor 404. The translator 454 has an information element reader 1410 that determines the sensor information, e.g. sensor type, manufacturer, calibration data, or security code from a sensor information element 452. The translator 454 also has an information element array 1420. The array 1420 is a predetermined set of different information elements that correspond to the possible sensors that the monitor 404 accepts. At least one information element is selected from the array 1420 and connected to the information element detector 450, as determined by a switching circuit 1430. The information element reader 1410 controls the state of the switching circuit 1430. In this manner, the information element reader 1410 can determine the sensor information element value, select an equivalent value from the information element array 1420, and actuate the switching circuit 1430, thereby connecting the corresponding element or elements from the array 1420 to the monitor information element detector 450.

[0076] FIG. 15 shows an embodiment of a sensor adapter which incorporates a combination of the adapter elements described above in addition to other elements described in detail below to create a universal adapter 1500. In general, the universal adapter 1500 allows one sensor 1502 from a variety of possible sensors to be connected to one monitor 1504 from a variety of possible monitors to create a pulse oximetry system. The universal adapter 1500 has a first connector adapter 1510, a monitor selector 1520, a first

switch 1530 and a number of adapter elements 1540. These components allow the universal adapter 1500 to sense the electrical characteristics of the monitor 1504, such as the drive configuration and drive levels, and to select the necessary adapter elements 1540 accordingly. The universal adapter 1500 also has a second connector adapter 1560, a sensor selector 1570, and a second switch 1580. These components allow the universal adapter to sense the electrical characteristics of the sensor 1502, such as LED configuration and information element presence and to select the necessary adapter elements 1540 accordingly.

[0077] FIG. 16 further illustrates the universal adapter 1500 described above with respect to FIG. 15. The universal adapter 1500 is shown as a sensor adapter cable 1600 having generic connectors 1610, 1620 at either end of the cable 1600. Attached to the cable and electrically connected to the cable wiring is a molded cable block 550 as described above with respect to FIG. 5. The cable block contains the adapter components 1520, 1530, 1540, 1570, 1580 shown in FIG. 15.

[0078] As illustrated in FIG. 16, a first connector adapter 1510 is a conventional adapter cable having a connector 1630 at one end which mates with the generic connector 1620 of the sensor adapter cable 1600. A connector 1640 at the other end of the connector adapter 1510 is the specific connector which mates with a particular monitor connector 1650. The cable wiring of the connector adapter 1510 is cross-wired between the end connectors 1630, 1640 as necessary to match the predetermined pinouts of the connector 1620 of the sensor adapter cable 1600 to the pinouts of the connector 1650 of the monitor 1504. In this manner, the first connector adapter 1510 accommodates a variety of physical connectors and pinouts of various monitors 1504.

[0079] Likewise, a second connector adapter 1560 is a conventional adapter cable having a connector 1660 at one end which mates with the generic connector 1610 of the sensor adapter cable 1600. A connector 1670 at the other end of the connector adapter 1560 is the specific connector 1670 which mates with a particular sensor connector 1680. The cable wiring of the connector adapter 1560 is cross-wired between the end connectors 1660, 1670 as necessary to match the predetermined pinouts of the connector 1610 of the sensor adapter cable 1600 to the pinouts of the connector 1680 of the sensor 1502. In this manner, the second connector adapter 1560 accommodates a variety of physical connectors and pinouts of various sensors 1502. The sensor adapter cable 1600, as described above, is advantageously of a single design having generic connectors 1610, 1620 with predetermined signal pinouts that mate with each of a family of specific adapter cables 1510, 1560 manufactured to match specific sensors 1502 and specific monitors 1504.

[0080] As illustrated in FIG. 15, the signal lines 1532 between the first switch 1530 and the connector adapter 1510 have branches 1522 to the monitor selector 1520. Because the pinouts of the universal adapter 1500 are predetermined, it is known which of these signal lines 1532 correspond to particular monitor leads 1512. Thus, the monitor selector 1520 tests these signal lines 1532 to determine the signal characteristics of an attached monitor 1504, as described in more detail below with respect to FIG. 17. Once the signal characteristics for the monitor 1504 are determined, the output 1524 of the monitor selector 1520

controls the first switch **1530** to connect the signal lines **1532** to corresponding adapter element **1540**.

[0081] Likewise, the signal lines **1582** between the second switch **1580** and the connector adapter **1560** have branches **1572** to the sensor selector **1570**. Because the pinouts of the universal adapter **1500** are predetermined, it is known which of these signal lines **1582** correspond to particular sensor leads **1562**. Thus, the sensor selector **1570** tests these signal lines **1582** to determine the signal characteristics of an attached sensor **1502**, as described in more detail below with respect to **FIG. 17**. Once the signal characteristics for the sensor **1502** are determined, the output **1574** of the sensor selector **1570** controls the second switch **1580** to connect the signal lines **1582** to corresponding ones of the adapter elements **1540**.

[0082] **FIG. 17** illustrates an embodiment for a configuration portion **1700** of the universal adapter **1500** that matches the monitor driver **1704** to the sensor LEDs **1702**. This configuration portion **1700** has a driver test **1710** and a switch control **1712**. The driver test **1710** senses the driver configuration from the monitor signal lines **1532** and provides an output **1714** to the switch control **1712**. The switch control **1712** has inputs from the driver test output **1714** and the LED test output **1724** and provides a control output **1718** that causes a first bi-directional switch **1530** to connect the monitor driver **1704** to the corresponding adapter elements **1731-1737**. That is, the first switch is equivalent to a bi-directional one-line to seven-line multiplexer.

[0083] The configuration portion **1700** also has an LED test **1720**. The LED test **1720** senses the LED configuration from the sensor signal lines **1582** and provides an output **1724** to the switch control **1712**. The switch control **1712** has inputs from the LED test output **1724** and the driver test output **1714** and provides a control output **1728** that causes a second bi-directional switch **1580** to connect the sensor LEDs **1702** to the corresponding adapter elements **1731-1737**. The second switch **1580** is equivalent to the first switch **1530**. The adapter elements comprise adapters **1732-1737** for all six combinations of drivers and incompatible sensor configurations. In addition, there is a "straight-through" adapter **1731** for the case of matching drivers and sensor LEDs, e.g. back-to-back driver **1704** and back-to-back LEDs **1702**.

[0084] As illustrated in **FIG. 17**, it is assumed that a monitor **1504** has three possible drivers **1704**. That is, an attached monitor will have circuitry for driving either back-to-back LEDs, common-anode LEDs or common-cathode LEDs. Thus, the configuration adapter **1700** has three signal lines **1532** from the monitor driver **1704**. For example, as illustrated in **FIG. 6**, a common-anode driver **410** has three leads **352, 354, 355** that correspond to the three signal lines **1532**. As illustrated in **FIG. 7** as another example, a back-to-back driver **410** has two leads **156, 158** which would correspond to two of the three signal lines **1532**, leaving one of the three signal lines **1532** unused.

[0085] **FIG. 18** illustrates an embodiment of the driver test **1710**. The driver test **1710** looks at the three signal lines **1532** to determine the driver configuration. The driver test circuit **1710** shown has three differential amplifiers **1810, 1820, 1830**, each with inputs across a unique pair of the three signal lines **1532**. That is, a first amplifier **1810** senses a signal on a first pair of signal lines **1802, 1804**, a second

amplifier **1820** senses a signal on a second pair of signal lines **1802, 1805**, and a third amplifier **1830** senses a signal on a third pair of signal lines **1804, 1805**.

[0086] If a monitor driver is configured for back-to-back LEDs, then, as illustrated in **FIG. 7**, the equivalent to driver leads **156, 158** are wired to correspond to signal lines **1802, 1804** shown in **FIG. 18**, respectively, and signal line **1805** is disconnected. The first amplifier **1810** would sense a voltage of alternating polarity corresponding to red LED and infrared LED drive signals, and the second amplifier **1820** and third amplifier **1830** would sense nothing. Hence, an alternating output voltage from only the first amplifier **1810** would indicate to the switch control **1712** in **FIG. 17** that the driver **1704** is configured for back-to-back LEDs.

[0087] As illustrated in **FIG. 18**, by contrast, if the monitor driver is configured for common-anode LEDs, then, as illustrated in **FIG. 6**, the equivalent to driver leads **352, 354, 355** are wired to correspond to signal lines **1802, 1804, 1805**, shown in **FIG. 18**, respectively. The first amplifier **1810** would sense a unipolar voltage corresponding to the red LED drive signal. The second amplifier **1820** would sense a unipolar voltage corresponding to the infrared LED drive signal. The third amplifier **1830** would sense nothing. Hence, alternating output voltages from the first amplifier **1810** and the second amplifier **1820** would indicate to the switch control **1712** in **FIG. 17** that the driver **1704** is configured for common-cathode LEDs. By comparison, if the monitor driver is configured for common cathode LEDs, a different two of the amplifiers **1810, 1820, 1830** would sense similar voltages as in the common-anode case. Thus, the outputs of the amplifiers **1810, 1820, 1830** provide sufficient information to the first switch control **1712** in **FIG. 17** to determine the driver configuration.

[0088] As illustrated in **FIG. 17**, it is assumed that a sensor **1502** has three possible LED configurations **1702**. That is, an attached sensor will have either back-to-back LEDs, common-anode LEDs or common-cathode LEDs. Thus, the configuration adapter **1700** has three signal lines **1582** from the sensor LEDs **1702**. For example, as illustrated in **FIG. 6**, a back-to-back LED sensor **412** has two leads **106, 108** that correspond to two of the three signal lines **1582**, leaving one of the three signal lines **1582** unused. As illustrated in **FIG. 7** as another example, a common-anode sensor **412** has three leads **302, 304, 305** that correspond to the three signal lines **1582**.

[0089] **FIG. 18** illustrates an embodiment of the LED test **1720**. The LED test **1720** looks at the three signal lines **1582** to determine the sensor configuration. The LED test circuit **1720** shown has a voltage source **1850** and two differential amplifiers **1860, 1870** that provide a return path for the voltage source **1850**. To test the sensor LED configuration, a switch **1880** alternately connects the voltage source **1850** to each of the three signal lines **1582** and, at the same time, connects the differential amplifiers **1860, 1870** to the remaining two signal lines **1582**. For example, in a first position **1882** (depicted), the output of the voltage source **1850** is connected to a first signal line **1806**, the input of the first amplifier **1860** is connected to a second signal line **1808**, and the input of the second amplifier **1870** is connected to a third signal line **1809**.

[0090] If a sensor has back-to-back LEDs, then, as illustrated in **FIG. 6**, the equivalent to sensor leads **106, 108** are

wired to correspond to signal lines **1806**, **1808** shown in **FIG. 18**, respectively, and signal line **1809** is disconnected. In the first switch position **1882**, the voltage source **1850** drives the red LED and current is detected by the first amplifier **1860**. In the second position **1884**, the voltage source **1850** drives the infrared LED and current is detected by the first amplifier **1860**. In the third switch position **1886**, the voltage source **1850** drives the disconnected line **1809** and no current is detected by either amplifier **1860**, **1870**. Hence, a voltage output from the first amplifier **1860** at the first and second switch positions **1882**, **1884**, with no amplifier output at the third switch position **1886**, indicates that the sensor has back-to-back LEDs.

[0091] As illustrated in **FIG. 18**, by contrast, if the sensor is configured for common-anode LEDs, then, as illustrated in **FIG. 7**, the equivalent to driver leads **302**, **304**, **305** are wired to correspond to signal lines **1806**, **1808**, **1809**, shown in **FIG. 18**, respectively. In the first switch position **1882**, the voltage source **1850** drives the anodes of both LEDs, but a current path is only provided by the input to the first amplifier **1860**, which produces a corresponding output. In the second and third switch positions **1884**, **1886** the voltage source **1850** back biases both LEDs and no current is detected by either amplifier **1860**, **1870**. Hence, a voltage output from the first amplifier **1860** at the first switch position **1882**, with no amplifier outputs at the second and third switch positions **1884**, **1886**, indicates that the sensor has common-anode LEDs. By comparison, if the sensor has common-cathode LEDs, in the first switch position **1882**, the voltage source **1850** would back-bias the diodes and no current would be detected by either amplifier **1860**, **1870**. In the second and third positions **1884**, **1886**, current would be detected by the first and second amplifiers **1860**, **1870**, respectively. Thus, the outputs of the amplifiers **1860**, **1870** provide sufficient information to the second switch control **1722** in **FIG. 17** to determine the sensor LED configuration.

[0092] As illustrated in **FIG. 17**, the switch control **1712** could be a simple state machine. After the LED test **1720** cycles through the three positions of the switch **1880** shown in **FIG. 18**, and after the driver test **1710** senses driver activation, the switch control **1712** would latch the first and second bi-direction switches **1530**, **1580** to connect the appropriate adapter element to the signal lines **1532**, **1582**. For example, if back-to-back LEDs **1702** were detected and a common-anode driver **1704** was detected, the bi-directional switches **1530**, **1580** would connect the three signal lines **1532**, **1582** to the common-anode (CA) to back-to-back (BB) adapter element **1734**. The CA to BB adapter element is described above with respect to **FIG. 6**.

[0093] As illustrated in **FIG. 15**, a simplified embodiment of the universal adapter **1500** is possible if the sensor **1502** is of a known configuration. For example, a sensor manufacturer may wish to provide a universal adapter **1500** between their particular sensors and most or all pulse oximetry monitors. In that case, there would be fewer combinations of adapter elements **1540** and the first switch **1530** and second switch **1580** would be simpler accordingly. For example, as illustrated in **FIG. 17**, if it is known that the sensor **1502** has back-to-back LEDs **1702**, then only the "straight-through" **1731**, "CA to BB" **1734** and "CC to BB" **1736** adapter elements are required. Correspondingly, the first switch **1530** and second switch **1580** would be

equivalent to bidirectional one-line to three-line multiplexers, rather than the more complex one-line to seven-line multiplexers shown.

[0094] One would appreciate that testing and switching circuitry, such as shown in **FIG. 17**, is also applicable to embodiments of, for example, drive limit portions and information translator portions of the universal adapter **1500** shown in **FIG. 15**. Further, one will recognize that portions of the sensor adapter shown in **FIGS. 4 and 15** could be implemented with microcontroller or microprocessor circuitry and associated firmware rather than in hardwired circuitry. Also, particular adapter elements might be selected manually, such as with hand-actuated switches, rather than through automatic sensing of the sensor and monitor configurations as described above. As another alternative to automatic sensing of the sensor and monitor configurations, particular connector adapters **1560**, **1510** could contain coding elements that function as indicators of the corresponding sensor **1502** or monitor **1504** configurations.

[0095] The pulse oximetry sensor adapter has been disclosed in detail in connection with the preferred embodiments of the present invention. These embodiments are disclosed by way of examples only and are not to limit the scope of the present invention, which is defined by the claims that follow. One in the art will appreciate many variations and modifications within the scope of this invention.

What is claimed is:

1. A universal adapter configured to connect one sensor from a variety of possible sensors to one monitor from a variety of possible monitors to create a pulse oximetry system, the universal adapter comprising:

- a first connector adapter configured for attachment to a monitor;
- a second connector adapter configured for attachment to a sensor; and
- a sensor adapter cable coupled between the first connector adapter and the second connector adapter, wherein the sensor adapter cable comprises:
 - a monitor selector configured to sense a drive configuration or drive levels of the monitor;
 - a sensor selector configured to sense a light emitting diode configuration or presence of an information element in the sensor;
 - a plurality of adapter elements configured to modify signals between the monitor and the sensor for compatible operations;
 - a first switching circuit configured to couple a selected adapter element to the monitor based on outputs from the monitor selector and the sensor selector, wherein the selected adapter element is one of the plurality of adapter elements; and
 - a second switching circuit configured to couple the selected adapter element to the sensor.

2. The universal adapter of claim 1 wherein the sensor adapter cable has generic connectors at each end with predetermined signal pinouts, the first connector adapter is a cross-wired cable with a generic connector at one end for mating with the first generic connector of the sensor adapter

cable and a specific connector at another end for mating with a specific type of monitor, and the second connector adaptor is a cross-wired cable with a generic connector at one end for mating with the second generic connector of the sensor adapter cable and a specific connector at another end for mating with a specific type of sensor.

3. The universal adapter of claim 2 wherein the monitor selector tests signal lines from the first generic connector of the sensor adapter cable to determine the drive configuration or the drive levels of the monitor while the sensor selector tests signal lines from the second generic connector of the sensor adapter cable to determine the light emitting diode configuration or presence of the information element in the sensor.

4. The universal adapter of claim 1 wherein the first switching circuit and the second switching circuit are bi-directional multiplexers.

5. The universal adapter of claim 1 wherein one of the plurality of adapter elements is a straight-through adapter for coupling a monitor with a normally compatible sensor.

6. The universal adapter of claim 1 wherein the monitor selector determines the drive configuration based on three signal lines connectable to the monitor, and the monitor selector comprises three differential amplifiers with each of the differential amplifiers having inputs coupled across a unique pair of the three signal lines.

7. The universal adapter of claim 1 wherein the sensor selector determines the light emitting diode configuration based on three signal lines connectable to the sensor, and the sensor selector comprises a voltage source that selectively connects to one of the three signal lines while two amplifiers selectively connect to the remaining two of the three signal lines.

8. A method to connect one sensor from a variety of possible sensors to one monitor from a variety of possible monitors, the method comprising:

- attaching a monitor to a first end of an adapter cable;
- attaching a sensor to a second end of the adapter cable;
- sensing a driver configuration of the monitor based on a first set of signal lines at the first end of the adapter cable;
- sensing a light emitting diode configuration of the sensor based on a second set of signal lines at the second end of the adapter cable;
- selecting an adapter element from a plurality of adapter elements in the adapter cable to interface the first set of signals with the second set of signals for compatible operation.

9. The method of claim 8 wherein attaching the monitor to the first end of the adapter cable comprises:

using an attachment cable with a specific connector at one end and a generic connector at another end, wherein the specific connector mates with a monitor connector and the generic connector mates with an adapter connector at the first end of the adapter cable; and

cross-wiring one or more cable wires between the specific connector and the generic connector in the attachment cable to match predetermined pinouts in the adapter connector.

10. The method of claim 8 wherein attaching the sensor to the second end of the adapter cable comprises:

using an attachment cable with a specific connector at one end and a generic connector at another end, wherein the specific connector mates with a sensor connector and the generic connector mates with an adapter connector at the second end of the adapter cable; and

cross-wiring one or more cable wires between the specific connector and the generic connector in the attachment cable to match predetermined pinouts in the adapter connector.

11. The method claim 8 wherein sensing the driver configuration of the monitor comprises detecting a differential voltage across at least one pair of signal lines in the first set of signal lines.

12. The method of claim 8 wherein sensing the light emitting diode configuration of the sensor comprises driving the signal lines in the second set of signal lines one at a time while detecting for current in the remaining signal lines.

13. The method of claim 8 wherein the first set of signal lines and the second set of signal lines comprise three signal lines each.

14. The method of claim 8 wherein bi-directional switches couple the selected adapter element to the appropriate signal lines.

15. A universal adapter comprising:

- means for attaching a monitor to a first standard connector at a first end of a sensor adapter cable;
- means for attaching a sensor to a second standard connector at a second end of the sensor adapter cable;
- means for testing a first set of signal lines in the first standard connector to determine monitor type;
- means for testing a second set of signal lines in the second standard connector to determine sensor type; and
- means for connecting the first set of signal lines and the second set of signal lines for compatible operation between the monitor and the sensor.

* * * * *

专利名称(译)	脉搏血氧仪传感器适配器		
公开(公告)号	US20060189859A1	公开(公告)日	2006-08-24
申请号	US11/341999	申请日	2006-01-27
[标]申请(专利权)人(译)	梅西莫股份有限公司		
申请(专利权)人(译)	Masimo公司		
当前申请(专利权)人(译)	摩根大通银行, NATIONAL ASSOCIATION		
[标]发明人	KIANI MASSI E SMITH ROBERT A TOBLER DAVID R		
发明人	KIANI, MASSI E. SMITH, ROBERT A. TOBLER, DAVID R.		
IPC分类号	A61B5/00		
CPC分类号	A61B5/14551 A61B5/14552 A61B2562/222 Y10S439/909		
其他公开文献	US7844313		
外部链接	Espacenet USPTO		

摘要(译)

适配器允许源自一个制造商的传感器的互连与源自其他制造商的常规不兼容的监视器耦合，以形成适当功能的脉搏血氧测量系统。适配器将监视器中的传感器驱动器与传感器的当前要求和光源配置相匹配。该适配器还将传感器的光检测器信号电平与监视器前置放大器的动态范围要求相匹配。此外，适配器为监视器提供兼容的传感器校准，传感器类型和安全信息。适配器可以具有独立的电源，或者它可以从监视器获得电力，允许无源和有源适配器组件。该适配器特别适合作为适配器电缆，取代传统的患者电缆或传感器电缆，作为脉搏血氧仪系统中传感器与监护仪之间的互连。

