



(19) **United States**

(12) **Patent Application Publication**
Zhirnov et al.

(10) **Pub. No.: US 2005/0251054 A1**

(43) **Pub. Date: Nov. 10, 2005**

(54) **METHOD AND APPARATUS FOR MEASUREMENT OF AUTONOMIC NERVOUS SYSTEM FUNCTION**

(52) **U.S. Cl. 600/509**

(75) **Inventors: Yevgeniy N. Zhirnov, Poulsbo, WA (US); Vadim I. Pougatchev, Poulsbo, WA (US); Evgueni N. Gribkov, Kingston, WA (US); Mark Ferris, Silverdale, WA (US)**

(57) **ABSTRACT**

The invention analyzes relationships between factors, within a patient population, to identify autonomic dysfunction patterns. Patient test results are then compared with the identified patterns to determine the patient's autonomic function. The invention can continually amend the patient population with new test results to create increasingly accurate normative data sets from which a patient's autonomic function can be more accurately assessed. The invention may apply this concept in an application service provider model. An embodiment of the invention may use a novel method of identifying ECG R-waves. The method locates R-waves by searching for maximum slope values, in signals, that exceed threshold values. Another embodiment of the invention entails a non-provocative HRV test whereby certain time domain and frequency domain factors are analyzed to determine a patient's autonomic function.

Correspondence Address:
Winstead Sechrest & Minick P.C.
P.O. Box 50784
Dallas, TX 75201 (US)

(73) **Assignee: MedPond, LLC, Austin, TX (US)**

(21) **Appl. No.: 10/842,294**

(22) **Filed: May 10, 2004**

Publication Classification

(51) **Int. Cl.⁷ A61B 5/04**

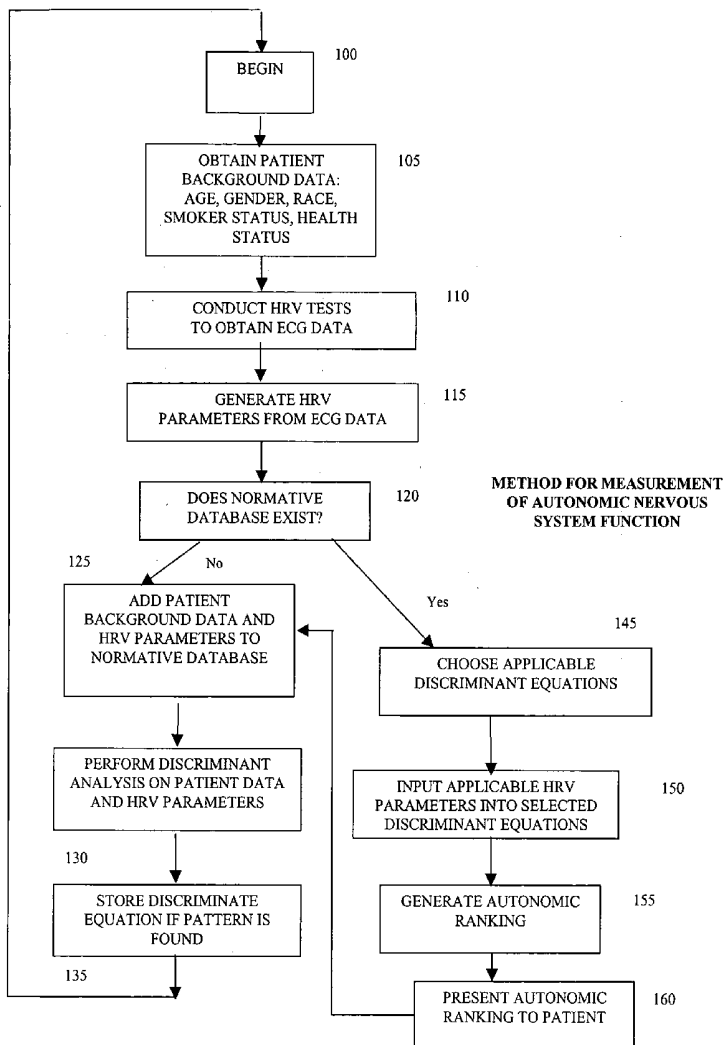

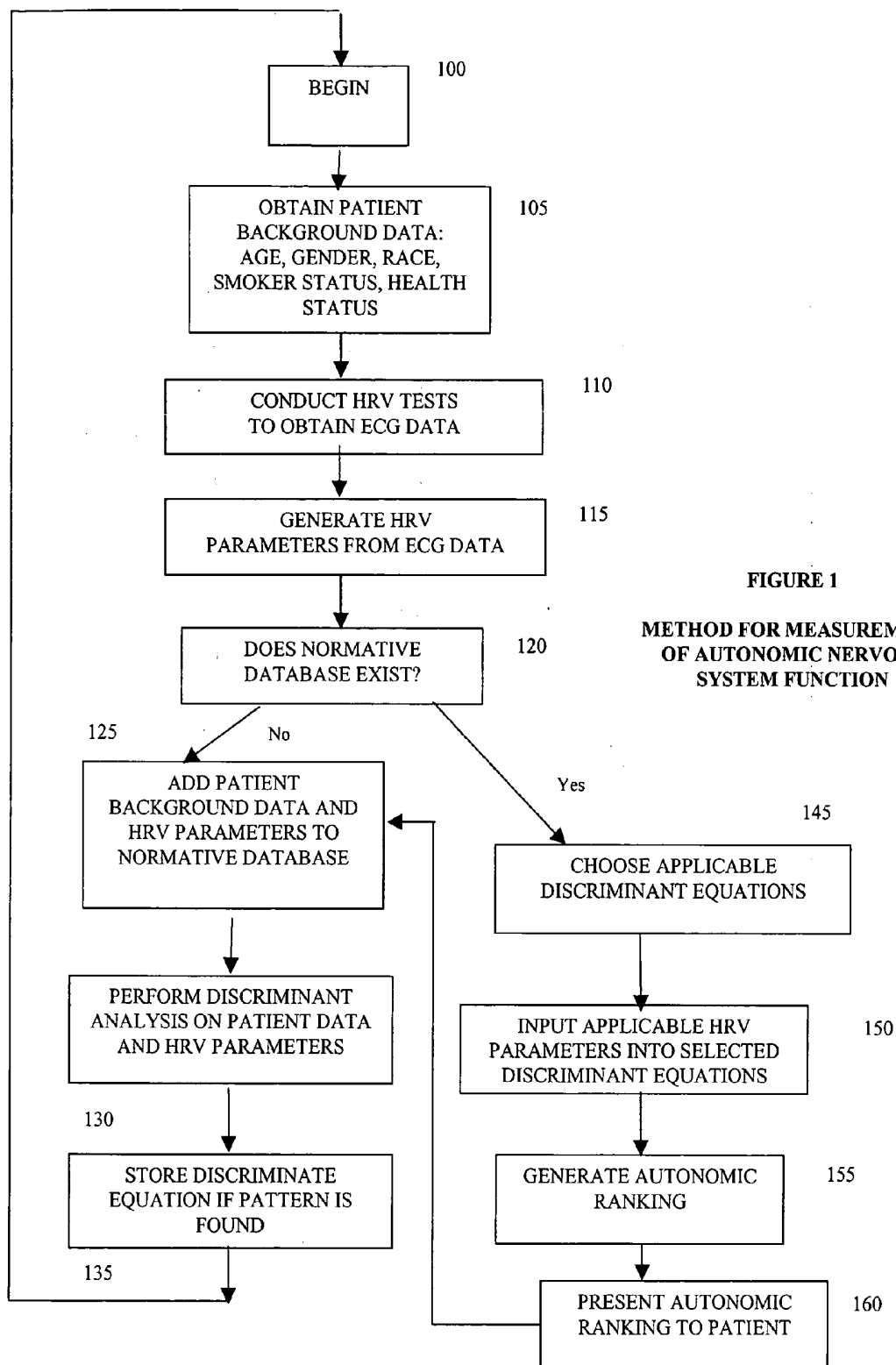

FIGURE 1

METHOD FOR MEASUREMENT
OF AUTONOMIC NERVOUS
SYSTEM FUNCTION

Subject Questionnaire

Subject must complete the following information list: Subject ID: _____

Personal Questions:

1. Age: ____ 2. Sex: Male Female 3. Height (ft-in): ____-____ 4. Weight (lb): ____-____
 5. How long in the USA (yrs): ____-____

6. Check your parent's most accurate belonging to Hispanic / Latino ethnicity:											
Father		Mother		Father		Mother		Father		Mother	
<input type="checkbox"/>	<input type="checkbox"/>	<input type="checkbox"/>	<input type="checkbox"/>	<input type="checkbox"/>	<input type="checkbox"/>	<input type="checkbox"/>	<input type="checkbox"/>	<input type="checkbox"/>	<input type="checkbox"/>	<input type="checkbox"/>	<input type="checkbox"/>
Central American		Mexican		South American		Other Hispanic		Native Hawaiian / Pacific Islander		Non-Hispanic	
Cuban		Puerto Rican						Hawaiian			
								Guamian			
								Samoan			
								Other NH/PI			
7. Check your parent's most accurate belonging to specific races:											
Father		Mother		Father		Mother		Father		Mother	
<input type="checkbox"/>	<input type="checkbox"/>	<input type="checkbox"/>	<input type="checkbox"/>	<input type="checkbox"/>	<input type="checkbox"/>	<input type="checkbox"/>	<input type="checkbox"/>	<input type="checkbox"/>	<input type="checkbox"/>	<input type="checkbox"/>	<input type="checkbox"/>
American Indian / Alaska Native		Asian		Black / African American		Black / African American		Native Hawaiian / Pacific Islander		White	
Alaskan		Cambodian		African American		African American		Hawaiian		Afghani	
Central American		Chinese		Caribbean		Caribbean		Guamian		Anglo-Saxon	
North American		Indian		Central African		Central African		Samoan		Arabian	
South American		Indonesian		East African		East African		Other NH/PI		Armenian	
		Japanese		North African		North African				Balkan	
		Korean		South African		South African				Baltic	
		Malaysian		West African		West African				French	
		Pakistani								German	
		Philippino								Greek	
		Thai								Irish	
		Vietnamese								Italian	
		Other Asian								Persian	
										Scandinavian	
										Semitic	
										Eastern Slavic	
										Western Slavic	
										Spanish	
										Turkish	
										Other White	
Type in your tribe name:											

Figure 2: Patient Background Information

Patient Questionnaire

Health Questions:

8. Did you have a physical exam (including blood test) within past 6 months? No Yes

9. Select any of the following that you now or have experienced in the past:

A. Symptoms / Complaints:					
<input type="checkbox"/> Anxiety / Panic Attack	<input type="checkbox"/> Backache	<input type="checkbox"/> Chest Pain	<input type="checkbox"/> Cold Feet / Hands	<input type="checkbox"/> Colic	
<input type="checkbox"/> Depression	<input type="checkbox"/> Digestive Problems	<input type="checkbox"/> Dizziness	<input type="checkbox"/> Extreme Fatigue	<input type="checkbox"/> Growing Pains	
<input type="checkbox"/> Headache	<input type="checkbox"/> Insomnia	<input type="checkbox"/> Leg Pain	<input type="checkbox"/> Loss of Memory	<input type="checkbox"/> Nausea / Vomit	
<input type="checkbox"/> Neck Aches	<input type="checkbox"/> Nervousness	<input type="checkbox"/> Numbness / Tingling	<input type="checkbox"/> Shortness of Breath	<input type="checkbox"/> Sinus Trouble	
<input type="checkbox"/> Tension	<input type="checkbox"/> Vision Problems				
B. Medical Conditions / Diagnosis					
<input type="checkbox"/> Allergies	<input type="checkbox"/> Arthritis	<input type="checkbox"/> Asthma	<input type="checkbox"/> Cancer	<input type="checkbox"/> Diabetes	
<input type="checkbox"/> Epilepsy	<input type="checkbox"/> Heart Disease	<input type="checkbox"/> Hepatitis	<input type="checkbox"/> High Blood Pressure	<input type="checkbox"/> Multiple Sclerosis	
<input type="checkbox"/> Muscular Dystrophy	<input type="checkbox"/> Parkinson Disease	<input type="checkbox"/> Rheumatism			

10. Alcohol consumption per week: No Yes Bottles of beer: _____ Glasses of wine: _____ Mixed/Other drinks: _____

11. Smoking: No Yes If yes, how many cigarettes per day: _____

If female, enter (where applicable):

12. Day of period: _____ 13. Week of pregnancy: _____ 14. Month of nursing: _____

Figure 3: Patient Health Information

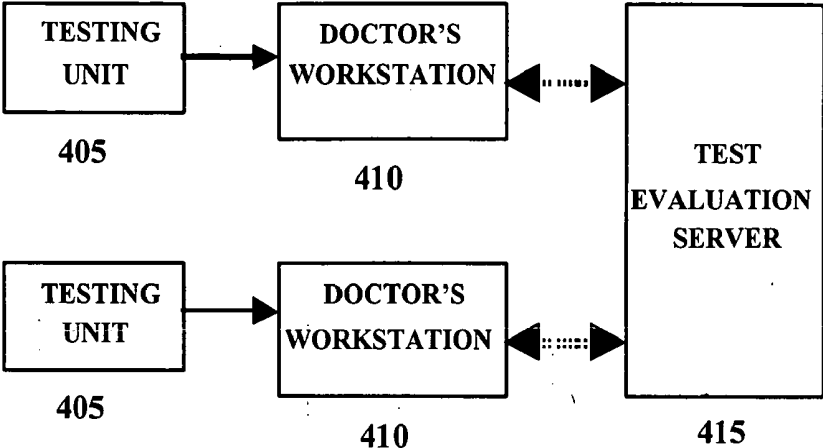

Figure 4: Example of internet-based HRV testing system.

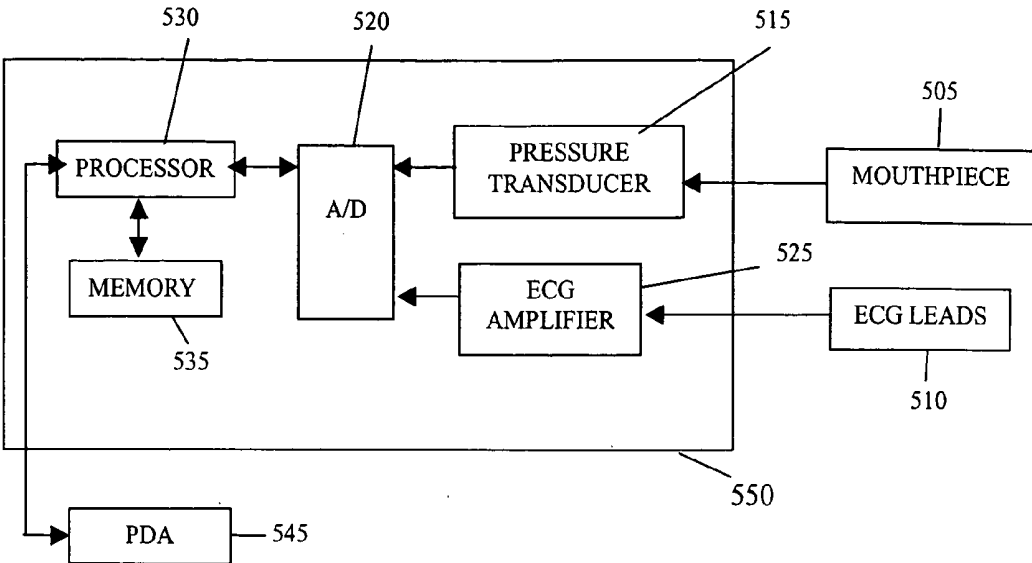

Figure 5: Example Block Diagram of Testing Unit

FIG. 6A

	STATUS	RMS-SD	TP	LFnorm	HFnorm	LF/HF	E/I Ratio	SD
1	DIABETES	50.93	380.94	30	70	0.428571	1.1889	62.12
2	DIABETES	58.039	389	29.75	70.25	0.423488	1.239	56.41
3	DIABETES	10.065	181.622	31.695	68.305	0.464022	1.116	35.25
4	DIABETES	52.93	382.94	25.31	74.69	0.338867	1.19	62.15
5	DIABETES	60.039	400	36	64	0.5625	1.24	58
6	DIABETES	10.07	182	32	68	0.470588	1.116	35.3
7	DIABETES	51.93	598	30	70	0.428571	1.18	62
8	DIABETES	51.9	687	30.15	69.85	0.431639	1.1889	62.12
9	DIABETES	58	220	25	75	0.333333	1.239	56.41
10	DIABETES	10.065	182.678	29.75	70.25	0.423488	1.116	35.25
11	DIABETES	52.93	648	31.695	68.305	0.464022	1.19	62.15
12	DIABETES	60.039	247	38	62	0.612903	1.24	58
13	DIABETES	10.07	182	22.36	77.64	0.287996	1.116	35.3
14	DIABETES	51.93	378	32	68	0.470588	1.18	62
15	DIABETES	59	268	40	60	0.666667	1.22	61
16	DIABETES	10	181	46	54	0.851852	1.114	35
17	DIABETES	11	182	29.75	70.25	0.423488	1.125	36
18	DIABETES	51.91	770	31.695	68.305	0.464022	1.1889	62.12
19	DIABETES	59	381	42.65	57.35	0.743679	1.239	56.41
20	DIABETES	10.065	184.678	31	69	0.449275	1.116	35.25
21	DIABETES	52.93	299	42	58	0.724138	1.19	62.15
22	DIABETES	60.039	384	32	68	0.470588	1.24	58
23	DIABETES	10.07	182	44	56	0.785714	1.116	35.3
24	DIABETES	51.93	378	44.4	55.6	0.798561	1.18	62
25	DIABETES	51.94	780	29.75	70.25	0.423488	1.1889	62.12
26	DIABETES	59.1	380	31.695	68.305	0.464022	1.239	56.41
27	DIABETES	10.065	182.6	36.65	63.35	0.578532	1.116	35.25
28	DIABETES	52.93	278	31	69	0.449275	1.19	62.15
29	DIABETES	60.039	155	32	68	0.470588	1.24	58
30	DIABETES	10.07	182	31	69	0.449275	1.116	35.3
31	DIABETES	51.93	794	22.36	77.64	0.287996	1.18	62
32	DIABETES	59	382	30	70	0.428571	1.223	47
33	DIABETES	25.25	379	65.3	34.7	1.881844	1.123	45.23
34	DIABETES	43.15	389	62.4	37.6	1.659574	1.234	51.23
35	DIABETES	35.12	181	61.32	38.68	1.585315	1.156	65.52
36	DIABETES	45.18	380	70.2	29.8	2.355705	1.22	64.25
37	DIABETES	54.78	405	65	35	1.857143	1.17	55.55
38	DIABETES	32.12	190	72	28	2.571429	1.18	54.12
39	DIABETES	22.16	600	70.94	29.06	2.441156	1.15	32.32
40	DIABETES	24.26	700	69.58	30.42	2.287311	1.19	39.34
41	DIABETES	28.46	230	60.35	39.65	1.522068	1.14	41.02
42	DIABETES	27.98	184	70.25	29.75	2.361345	1.187	63.25
43	DIABETES	45.56	650	71.94	28.06	2.563792	1.244	71.25
44	DIABETES	35.46	250	60	40	1.5	1.211	70.02

FIG. 6B

	STATUS	RMS-SD	TP	LFnorm	HFnorm	LF/HF	E/I Ratio	SD
45	DIABETES	37.48	190	80	20	4	1.201	34.56
46	DIABETES	35.24	389	70.25	29.75	2.361345	1.222	45.12
47	DIABETES	33.25	267	63.25	36.75	1.721088	1.189	47.18
48	DIABETES	21.24	182	64.25	35.75	1.797203	1.245	43.26
49	DIABETES	20.21	182	64.36	35.64	1.805836	1.248	43.46
50	DIABETES	36.38	779	71	29	2.448276	1.188	55.23
51	DIABETES	47.56	390	63	37	1.702703	1.177	41.95
52	DIABETES	35.47	187	78	22	3.545455	1.165	33.28
53	DIABETES	24.22	320	73	27	2.703704	1.128	39.15
54	DIABETES	54.24	398	66	34	1.941176	1.1364	41.23
55	DIABETES	51.2	399	76	24	3.166667	1.211	45.11
56	DIABETES	47.45	350	70.25	29.75	2.361345	1.239	36.31
57	DIABETES	24.35	790	70.26	29.74	2.362475	1.237	32.15
58	DIABETES	24.26	394	61.25	38.75	1.580645	1.235	31.24
59	DIABETES	27.28	200	78.23	21.77	3.593477	1.236	30.12
60	DIABETES	27.39	230	70.36	29.64	2.373819	1.237	34.69
61	DIABETES	31.29	190	68	32	2.125	1.122	38.15
62	DIABETES	31.89	185	69.68	30.32	2.298153	1.126	39.12
63	DIABETES	32.56	845	61.23	38.77	1.579314	1.238	41.32
64	DIABETES	33.46	425	62.54	37.46	1.669514	1.24	41.36
65	HEALTHY	119.14	2300	29	71	0.408451	1.68	153.9755
66	HEALTHY	120	2000	30	70	0.428571	1.681	153.8888
67	HEALTHY	63.34	1500.03	32	68	0.470588	1.603	138.509
68	HEALTHY	86.78	3331.34	26	74	0.351351	1.62	141.3
69	HEALTHY	121	2589	36	64	0.5625	1.688	154
70	HEALTHY	65	3244	32	68	0.470588	1.62	139
71	HEALTHY	125	2999	30	70	0.428571	1.611	158
72	HEALTHY	70.8	3400	30.15	69.85	0.431639	1.59	152
73	HEALTHY	70.7	2498.7	25	75	0.333333	1.57	151
74	HEALTHY	119.18	1902.56	29.75	70.25	0.423488	1.685	153.8812
75	HEALTHY	63.34	2500	31.695	68.305	0.464022	1.603	138.509
76	HEALTHY	86.78	3331.34	38	62	0.612903	1.65	141.3
77	HEALTHY	126	2456	22.36	77.64	0.287996	1.688	154
78	HEALTHY	65	2220	40.52	59.48	0.681237	1.62	135
79	HEALTHY	121	3125	40	60	0.666667	1.611	170
80	HEALTHY	70.8	2400	46	54	0.851852	1.59	152
81	HEALTHY	119.111	1902.56	29.75	70.25	0.423488	1.689	153.9456
82	HEALTHY	63.34	2899	50.29	49.71	1.011668	1.603	138.509
83	HEALTHY	86.78	3331.34	42.65	57.35	0.743679	1.7	141.3
84	HEALTHY	128	2698	31	69	0.449275	1.688	154
85	HEALTHY	65	2487	42	58	0.724138	1.62	140
86	HEALTHY	129	2789	32	68	0.470588	1.611	171
87	HEALTHY	70.8	2777	44	56	0.785714	1.59	152
88	HEALTHY	70.7	2498.7	44.4	55.6	0.798561	1.57	152
89	HEALTHY	119.119	2902.35	29.75	70.25	0.423488	1.675	153.9999

FIG. 6C

	STATUS	RMS-SD	TP	LFnorm	HFnorm	LF/HF	E/I Ratio	SD
90	HEALTHY	63.34	3458.59	55.56	44.44	1.250225	1.603	138.509
91	HEALTHY	86.78	3331.34	36.65	63.35	0.578532	1.61	141.3
92	HEALTHY	119	2945.36	31	69	0.449275	1.688	154
93	HEALTHY	65	3215.25	32	68	0.470588	1.62	141
94	HEALTHY	122.356	3000.02	31	69	0.449275	1.611	159
95	HEALTHY	70.8	2400	22.36	77.64	0.287996	1.59	152
96	HEALTHY	121	4056	30	70	0.428571	1.611	160
97	HEALTHY	121	2932.569	32	68	0.470588	1.611	158
98	HEALTHY	119.14	2300	29	71	0.408451	1.68	153.9755
99	HEALTHY	120	2000	28	72	0.388889	1.681	153.8888
100	HEALTHY	63.34	1500.03	50.1	49.9	1.004008	1.603	138.509
101	HEALTHY	86.78	3331.34	24.26	75.74	0.320306	1.62	141.3
102	HEALTHY	121	2589	38	62	0.612903	1.688	154
103	HEALTHY	65	3244	30	70	0.428571	1.62	139
104	HEALTHY	125	2999	32	68	0.470588	1.611	158
105	HEALTHY	70.8	3400	60.23	39.77	1.514458	1.59	152
106	HEALTHY	70.7	2498.7	25	75	0.333333	1.57	151
107	HEALTHY	119.18	1902.56	30.25	69.75	0.433692	1.685	153.8812
108	HEALTHY	63.34	2500	32.25	67.75	0.476015	1.603	138.509
109	HEALTHY	86.78	3331.34	60.74	39.26	1.547122	1.65	141.3
110	HEALTHY	126	2456	23.25	76.75	0.302932	1.688	154
111	HEALTHY	65	2220	32.45	67.55	0.480385	1.62	135
112	HEALTHY	121	3125	41.26	58.74	0.702417	1.611	170
113	HEALTHY	70.8	2400	47.48	52.52	0.904037	1.59	152
114	HEALTHY	119.111	1902.56	28.75	71.25	0.403509	1.689	153.9456
115	HEALTHY	63.34	2899	30.945	69.055	0.448121	1.603	138.509
116	HEALTHY	86.78	3331.34	40.25	59.75	0.67364	1.7	141.3
117	HEALTHY	128	2698	54.52	45.48	1.198769	1.688	154
118	HEALTHY	65	2487	45.59	54.41	0.837897	1.62	140
119	HEALTHY	129	2789	29.98	70.02	0.428163	1.611	171
120	HEALTHY	70.8	2777	48.56	51.44	0.944012	1.59	152
121	HEALTHY	70.7	2498.7	48.21	51.79	0.930875	1.57	152
122	HEALTHY	119.119	2902.35	52.23	47.77	1.093364	1.675	153.9999
123	HEALTHY	63.34	3458.59	25.65	74.35	0.34499	1.603	138.509
124	HEALTHY	86.78	3331.34	39.25	60.75	0.646091	1.61	141.3
125	HEALTHY	119	2945.36	29.15	70.85	0.411433	1.688	154
126	HEALTHY	65	3215.25	24.56	75.44	0.325557	1.62	141
127	HEALTHY	122.356	3000.02	38.26	61.74	0.619695	1.611	159
128	HEALTHY	70.8	2400	25.68	74.32	0.345533	1.59	152

FIG. 6D

	STATUS	30:15 Ratio	NN	SDNN	VLF	LF	HF	NNmin SB
1	DIABETES	1.235	862	53.6	213.6642	652.32	1522.08	616
2	DIABETES	1.287	860	50.8	300	506.345	1195.655	796
3	DIABETES	1.182	790	51.9	127.0011	435.8158	939.2142	532
4	DIABETES	1.296	860	49.8	213.6704	538.4298	1588.91	600
5	DIABETES	1.289	865	48.9	169	717.3504	1275.29	580
6	DIABETES	1.18	869	50.1	110	997.7642	2120.249	550
7	DIABETES	1.278	864	55.5	239.4186	562.737	1313.053	700
8	DIABETES	1.269	850	49	233.9176	625.5371	1449.213	730
9	DIABETES	1.287	851	45.2	142	377.3525	1132.058	680
10	DIABETES	1.182	854	44	97.30658	199.9379	472.1222	578
11	DIABETES	1.247	859	43.96	244.9982	649.0502	1398.75	592
12	DIABETES	1.289	869	36.58	125	762.7436	1244.476	658
13	DIABETES	1.181	866	30.58	99.78	468.8892	1628.111	612
14	DIABETES	1.236	778	36.5	180.0256	521.6	1108.4	623
15	DIABETES	1.28	779	37.8	120	690	1035	684
16	DIABETES	1.18	880	32.35	55.0896	506	594	724
17	DIABETES	1.188	875	31.36	142.3022	209.0116	493.5484	689
18	DIABETES	1.245	873	39.56	234.6695	745.9862	1607.654	678
19	DIABETES	1.287	865	40.1	132.24	893.9355	1202.045	625
20	DIABETES	1.182	836	42.5	112.23	491.8956	1094.864	624
21	DIABETES	1.278	853	44.44	182.9992	793.3296	1095.55	599
22	DIABETES	1.289	859	51.48	212	853.1264	1812.894	726
23	DIABETES	1.188	878	49.26	98	638.88	813.12	720
24	DIABETES	1.284	873	47.43	223.808	556.6428	697.0572	580
25	DIABETES	1.296	879	33.89	230.1308	496.3044	1171.946	594
26	DIABETES	1.287	861	35.28	300	1088.815	2346.475	577
27	DIABETES	1.182	877	30.333	65.25	1012.72	1750.5	588
28	DIABETES	1.281	899	35	169.1333	804.2516	1790.108	645
29	DIABETES	1.289	898	35.369	37.43475	809.8496	1720.93	625
30	DIABETES	1.1897	888	45.87	110.11	698.9818	1555.798	619
31	DIABETES	1.269	875	46.21	247.8114	252.8916	878.1084	684
32	DIABETES	1.28	859	35.39	215	810	1890	675
33	DIABETES	1.189	862	50	210.23	110.2068	58.56319	600
34	DIABETES	1.126	854	36	256.35	82.7736	49.8764	610
35	DIABETES	1.299	859	45.59	125.03	34.3208	21.6492	620
36	DIABETES	1.264	864	48.23	198.23	127.6025	54.16746	630
37	DIABETES	1.185	870	51.23	168.36	153.816	82.824	740
38	DIABETES	1.234	878	32.56	120	50.4	19.6	720
39	DIABETES	1.2	887	39.15	240	255.384	104.616	654
40	DIABETES	1.211	854	42.15	235.68	323.0739	141.2461	586
41	DIABETES	1.236	851	37.29	145.68	50.88712	33.43288	687
42	DIABETES	1.245	845	42.15	98.69	59.93028	25.37973	623
43	DIABETES	1.281	879	44.26	256.36	283.1846	110.4554	642
44	DIABETES	1.263	881	49.25	169.36	48.384	32.256	649

FIG. 6E

	STATUS	30:15 Ratio	NN	SDNN	VLF	LF	HF	NNmin SB
45	DIABETES	1.245	865	43.21	100.35	71.72	17.93	687
46	DIABETES	1.278	859	36.12	190.25	139.6219	59.12813	702
47	DIABETES	1.256	867	37.89	135.25	83.33188	48.41813	711
48	DIABETES	1.212	866	37.45	57.36	80.0812	44.5588	623
49	DIABETES	1.246	839	45.12	150.26	20.42786	11.31214	645
50	DIABETES	1.239	841	42.31	250.34	375.3486	153.3114	690
51	DIABETES	1.248	829	50	140.25	157.3425	92.4075	689
52	DIABETES	1.284	874	43.12	114.26	56.7372	16.0028	674
53	DIABETES	1.264	840	44.44	189.35	95.3745	35.2755	598
54	DIABETES	1.234	836	46.21	210.23	123.9282	63.8418	578
55	DIABETES	1.245	839	36.36	100.25	227.05	71.7	534
56	DIABETES	1.284	845	46.23	220.31	91.10723	38.58278	596
57	DIABETES	1.267	824	48.2	210.36	407.2551	172.3849	578
58	DIABETES	1.234	810	47.25	298.23	58.65913	37.11088	569
59	DIABETES	1.247	842	40.12	70.25	101.5034	28.24658	610
60	DIABETES	1.236	812	39.98	160.24	49.08314	20.67686	623
61	DIABETES	1.248	862	39.21	39.25	102.51	48.24	627
62	DIABETES	1.239	818	34.58	112.12	50.78278	22.09722	638
63	DIABETES	1.247	880	36.31	250.35	364.1042	230.5458	659
64	DIABETES	1.294	835	38.89	222.35	126.7373	75.91269	645
65	HEALTHY	1.568	886	40.56	125.6	630.576	1543.824	650
66	HEALTHY	1.5988	885	55.69	298	510.6	1191.4	620
67	HEALTHY	1.5	880	60.45	125	440.0096	935.0204	556
68	HEALTHY	1.45	870	59.58	1204	553.1084	1574.232	600
69	HEALTHY	1.599	890	58.98	596.36	717.3504	1275.29	500
70	HEALTHY	1.555	887	60.25	125.987	997.7642	2120.249	777
71	HEALTHY	1.618	899	40.12	1123.21	562.737	1313.053	775
72	HEALTHY	1.46	900	43.25	1325.25	625.5371	1449.213	745
73	HEALTHY	1.468	901	57.96	989.29	377.3525	1132.058	510
74	HEALTHY	1.5562	859	66.39	1230.5	199.9379	472.1222	630
75	HEALTHY	1.5	845	68.15	452.2	649.0502	1398.75	614
76	HEALTHY	1.45	865	69.12	1324.12	762.7436	1244.476	514
77	HEALTHY	1.599	867	63.25	359	468.8892	1628.111	800
78	HEALTHY	1.551	896	58.9	590	660.476	969.524	700
79	HEALTHY	1.618	869	70.1	1400	690	1035	625
80	HEALTHY	1.52	870	63.45	1300	506	594	645
81	HEALTHY	1.512	893	68.48	1200	209.0116	493.5484	678
82	HEALTHY	1.5	894	69.37	545.36	1183.646	1169.994	698
83	HEALTHY	1.55	899	45.96	1235.36	893.9355	1202.045	659
84	HEALTHY	1.599	910	87.61	1111.24	491.8956	1094.864	600
85	HEALTHY	1.552	783	56.3	598.12	793.3296	1095.55	645
86	HEALTHY	1.618	873	55.55	122.98	853.1264	1812.894	687
87	HEALTHY	1.46	854	59.63	1325	638.88	813.12	698
88	HEALTHY	1.54	864	39.39	1245	556.6428	697.0572	589
89	HEALTHY	1.522	869	38	1234.1	496.3044	1171.946	584

FIG. 6F

	STATUS	30:15 Ratio	NN	SDNN	VLF	LF	HF	NNmin SB
90	HEALTHY	1.5	894	33	23.3	1908.647	1526.643	678
91	HEALTHY	1.56	900	45.96	568.12	1012.72	1750.5	594
92	HEALTHY	1.599	874	40	351	804.2516	1790.108	678
93	HEALTHY	1.554	865	39	684.47	809.8496	1720.93	645
94	HEALTHY	1.618	896	40	745.24	698.9818	1555.798	635
95	HEALTHY	1.49	900	38	1269	252.8916	878.1084	600
96	HEALTHY	1.618	856	59.12	1356	810	1890	620
97	HEALTHY	1.618	789	56.32	1200	554.4221	1178.147	580
98	HEALTHY	1.568	886	40.56	1254	306.385	750.115	650
99	HEALTHY	1.5988	885	55.69	359	463.68	1192.32	620
100	HEALTHY	1.5	880	60.45	987	282.063	280.937	556
101	HEALTHY	1.45	870	59.58	1201	517.7084	1616.292	600
102	HEALTHY	1.599	890	58.98	445	836	1364	500
103	HEALTHY	1.555	887	60.25	168	972.6	2269.4	777
104	HEALTHY	1.618	899	40.12	1126	606.4	1288.6	775
105	HEALTHY	1.46	900	43.25	1329	1282.297	846.7033	745
106	HEALTHY	1.468	901	57.96	1011	362	1086	510
107	HEALTHY	1.5562	859	66.39	1239	239.58	552.42	630
108	HEALTHY	1.5	845	68.15	468	543.735	1142.265	614
109	HEALTHY	1.45	865	69.12	1354	1220.874	789.126	514
110	HEALTHY	1.599	867	63.25	458	488.9475	1614.053	800
111	HEALTHY	1.551	896	58.9	684	7390.163	15383.84	700
112	HEALTHY	1.618	869	70.1	1542	708.0216	1007.978	625
113	HEALTHY	1.52	870	63.45	1450	521.3304	576.6696	645
114	HEALTHY	1.512	893	68.48	1320	180.55	447.45	678
115	HEALTHY	1.5	894	69.37	654	678.005	1512.995	698
116	HEALTHY	1.55	899	45.96	1253	842.835	1251.165	659
117	HEALTHY	1.599	910	87.61	1245	764.9156	638.0844	600
118	HEALTHY	1.552	783	56.3	645	912.7118	1089.288	645
119	HEALTHY	1.618	873	55.55	199	794.47	1855.53	687
120	HEALTHY	1.46	854	59.63	145	1132.905	1200.095	698
121	HEALTHY	1.54	864	39.39	1245	628.1763	674.8237	589
122	HEALTHY	1.522	869	38	1475	807.4758	738.5242	584
123	HEALTHY	1.5	894	33	50.25	819.4534	2375.297	678
124	HEALTHY	1.56	900	45.96	640	1156.698	1790.303	594
125	HEALTHY	1.599	874	40	451	8676.206	21087.79	678
126	HEALTHY	1.554	865	39	780	7769.556	23865.44	645
127	HEALTHY	1.618	896	40	740	11675.8	18841.2	635
128	HEALTHY	1.49	900	38	1201	358.4928	1037.507	600

FIG. 6G

	STATUS	NNmax SB	VARmax	VARmean	NNmin Standing	NNmax Standing	Tmax	Trec
1	DIABETES	772	116	75.33334	592	731.12	14	50
2	DIABETES	1056	216	157.3333	692	890.604	15	49
3	DIABETES	716	150	74.22222	516	609.912	8.112	28.7
4	DIABETES	888	250	300	502	650.592	14	48
5	DIABETES	750	169	290	545	702.505	12	29.1
6	DIABETES	780	178	270	584	689.12	14	20.4
7	DIABETES	930	245	310	597	762.966	12	25.5
8	DIABETES	940	187	190	587	744.903	11	41.1
9	DIABETES	900	450	222	578	743.886	13.5	20.3
10	DIABETES	1000	444	241	514	607.548	13.5	26
11	DIABETES	800	215	198	640	798.08	12.4	32
12	DIABETES	859	142	235	658	848.162	10.2	25
13	DIABETES	830	158	265	632	746.392	12	47
14	DIABETES	999	358	289	647	799.692	6.5	25
15	DIABETES	800	136	245	694	888.32	7.8	14
16	DIABETES	1002	296	268	555	654.9	9.8	16
17	DIABETES	987	198	247	532	632.016	9.9	21
18	DIABETES	952	169	286	547	681.015	10.2	31
19	DIABETES	858	178	294	568	731.016	12.12	24
20	DIABETES	900	289	289	512	605.184	3.6	12
21	DIABETES	956	125	258	598	764.244	4.59	16
22	DIABETES	1020	358	300	599	772.111	5.49	18
23	DIABETES	945	258	100	547	649.836	10	46
24	DIABETES	788	152	120	532	683.088	11	45
25	DIABETES	759	163	184	587	760.752	8.27	16
26	DIABETES	840	189	198	514	661.518	9.47	18
27	DIABETES	845	167	174	597	705.654	10.24	21
28	DIABETES	901	176	162	520	666.12	11.26	23
29	DIABETES	897	185	132	600	773.4	13.25	32
30	DIABETES	864	197	213	620	737.614	12.64	28
31	DIABETES	826	145	248	573	727.137	13.478	29
32	DIABETES	845	165	264	610	780.8	12.2	26
33	DIABETES	710	125	258	598	764.244	4.59	16
34	DIABETES	842	358	300	599	772.111	5.49	18
35	DIABETES	924	258	100	547	649.836	10	46
36	DIABETES	1001	152	120	532	683.088	11	45
37	DIABETES	954	163	184	587	760.752	8.27	16
38	DIABETES	978	189	198	514	661.518	9.47	18
39	DIABETES	879	167	174	597	705.654	10.24	21
40	DIABETES	789	176	162	520	666.12	11.26	23
41	DIABETES	1020	185	132	600	773.4	13.25	32
42	DIABETES	987	197	213	620	737.614	12.64	28
43	DIABETES	896	145	248	573	727.137	13.478	29
44	DIABETES	978	165	264	610	780.8	12.2	26

FIG. 6H

	STATUS	NNmax SB	VARmax	VARmean	NNmin Standing	NNmax Standing	Tmax	Trec
45	DIABETES	912	215	198	640	798.08	12.4	32
46	DIABETES	924	142	235	658	848.162	10.2	25
47	DIABETES	877	158	265	632	746.392	12	47
48	DIABETES	892	358	289	647	799.692	6.5	25
49	DIABETES	846	136	245	694	888.32	7.8	14
50	DIABETES	879	116	75.33334	592	731.12	14	50
51	DIABETES	800	216	157.33333	692	890.604	15	49
52	DIABETES	799	150	74.222222	516	609.912	8.112	28.7
53	DIABETES	725	250	300	502	650.592	14	48
54	DIABETES	769	169	290	545	702.505	12	29.1
55	DIABETES	789	178	270	584	689.12	14	20.4
56	DIABETES	748	245	310	597	762.966	12	25.5
57	DIABETES	762	187	190	587	744.903	11	41.1
58	DIABETES	697	450	222	578	743.886	13.5	20.3
59	DIABETES	890	444	241	514	607.548	13.5	26
60	DIABETES	999	215	198	640	798.08	12.4	32
61	DIABETES	942	142	235	658	848.162	10.2	25
62	DIABETES	978	158	265	632	746.392	12	47
63	DIABETES	936	358	289	647	799.692	6.5	25
64	DIABETES	941	136	245	694	888.32	7.8	14
65	HEALTHY	972	430	362.8571	524	821.632	6.032	12.65
66	HEALTHY	1060	432	390	580	927.304	7.78	33.1
67	HEALTHY	1016	387	373.3	600	900	6.5	12
68	HEALTHY	912	198	215	690	1000.5	10.2	19
69	HEALTHY	1015	265	298	700	1119.3	12.3	25
70	HEALTHY	1000	264	245	710	1104.05	15.4	21
71	HEALTHY	948	284	213	540	873.72	15	23
72	HEALTHY	845	298	129	789	1151.94	13.2	28
73	HEALTHY	895	332	194	820	1203.76	10.1	18
74	HEALTHY	869	386	182	520	809.224	12.36	25
75	HEALTHY	1078	450	324	546	819	14.25	21
76	HEALTHY	758	444	389	652	945.4	12.25	26
77	HEALTHY	897	412	400	547	874.653	10	12
78	HEALTHY	890	465	148	842	1305.942	10.245	24
79	HEALTHY	1005	478	234	700	1132.6	12.589	25
80	HEALTHY	1203	429	258	582	884.64	14.36	29
81	HEALTHY	945	412	247	664	1003.968	14.56	27
82	HEALTHY	947	495	298	657	985.5	11.12	21
83	HEALTHY	894	487	278	698	1081.9	13.45	23
84	HEALTHY	800	452	245	621	992.979	14.23	25
85	HEALTHY	1030	335	139	675	1047.6	12.1	19
86	HEALTHY	1050	345	199	691	1118.038	6.1	11
87	HEALTHY	1015	256	321	701	1023.46	12.35	31
88	HEALTHY	985	199	360	750	1155	14.23	30
89	HEALTHY	1026	326	260	710	1080.62	13.2	24

FIG. 6I

	STATUS	NNmax SB	VARmax	VARmean	NNmin Standing	NNmax Standing	Tmax	Trec
90	HEALTHY	895	333	241	760	1140	14.2	21
91	HEALTHY	947	302	299	754	1176.24	10.1	26
92	HEALTHY	855	245	278	589	941.811	9.8	15
93	HEALTHY	879	574	245	623	968.142	8.56	19
94	HEALTHY	984	458	265	547	885.046	4.56	18
95	HEALTHY	1011	698	248	594	885.06	9.9	13
96	HEALTHY	968	578	247	620	1003.16	8.97	17
97	HEALTHY	892	400	267	623	1008.014	7.77	18
98	HEALTHY	972	430	362.8571	524	821.632	6.032	12.65
99	HEALTHY	1060	432	390	580	927.304	7.78	33.1
100	HEALTHY	1016	387	373.3	600	900	6.5	12
101	HEALTHY	912	198	215	690	1000.5	10.2	19
102	HEALTHY	1015	265	298	700	1119.3	12.3	25
103	HEALTHY	1000	264	245	710	1104.05	15.4	21
104	HEALTHY	948	284	213	540	873.72	15	23
105	HEALTHY	845	298	129	789	1151.94	13.2	28
106	HEALTHY	895	332	194	820	1203.76	10.1	18
107	HEALTHY	869	386	182	520	809.224	12.36	25
108	HEALTHY	1078	450	324	546	819	14.25	21
109	HEALTHY	758	444	389	652	945.4	12.25	26
110	HEALTHY	897	412	400	547	874.653	10	12
111	HEALTHY	890	465	148	842	1305.942	10.245	24
112	HEALTHY	1005	478	234	700	1132.6	12.589	25
113	HEALTHY	1203	429	258	582	884.64	14.36	29
114	HEALTHY	945	412	247	664	1003.968	14.56	27
115	HEALTHY	947	495	298	657	985.5	11.12	21
116	HEALTHY	894	487	278	698	1081.9	13.45	23
117	HEALTHY	800	452	245	621	992.979	14.23	25
118	HEALTHY	1030	335	139	675	1047.6	12.1	19
119	HEALTHY	1050	345	199	691	1118.038	6.1	11
120	HEALTHY	1015	256	321	701	1023.46	12.35	31
121	HEALTHY	985	199	360	750	1155	14.23	30
122	HEALTHY	1026	326	260	710	1080.62	13.2	24
123	HEALTHY	895	333	241	760	1140	14.2	21
124	HEALTHY	947	302	299	754	1176.24	10.1	26
125	HEALTHY	855	245	278	589	941.811	9.8	15
126	HEALTHY	879	574	245	623	968.142	8.56	19
127	HEALTHY	984	458	265	547	885.046	4.56	18
128	HEALTHY	1011	698	248	594	885.06	9.9	13

FIG. 7A

	Group	Root 1
1	DIABETES	-9.3476
2	DIABETES	-9.5232
3	DIABETES	-10.9865
4	DIABETES	-8.7242
5	DIABETES	-8.5884
6	DIABETES	-11.2693
7	DIABETES	-9.3140
8	DIABETES	-9.1278
9	DIABETES	-9.0959
10	DIABETES	-11.0725
11	DIABETES	-9.2374
12	DIABETES	-9.2027
13	DIABETES	-11.5562
14	DIABETES	-9.7996
15	DIABETES	-9.4991
16	DIABETES	-11.5911
17	DIABETES	-11.1149
18	DIABETES	-8.9963
19	DIABETES	-8.8818
20	DIABETES	-11.1577
21	DIABETES	-9.1943
22	DIABETES	-9.0558
23	DIABETES	-11.4325
24	DIABETES	-9.0223
25	DIABETES	-8.5841
26	DIABETES	-8.6345
27	DIABETES	-11.3819
28	DIABETES	-9.0559
29	DIABETES	-9.0454
30	DIABETES	-11.4657
31	DIABETES	-9.1082
32	DIABETES	-10.3832
33	DIABETES	-10.7665
34	DIABETES	-9.1357
35	DIABETES	-8.6845
36	DIABETES	-7.6954
37	DIABETES	-10.8222
38	DIABETES	-9.0884
39	DIABETES	-11.3924
40	DIABETES	-9.1799
41	DIABETES	-11.0873

FIG. 7B

42	DIABETES	-8.2295
43	DIABETES	-6.4428
44	DIABETES	-7.1334
45	DIABETES	-11.1983
46	DIABETES	-9.2538
47	DIABETES	-10.1610
48	DIABETES	-8.4712
49	DIABETES	-8.2188
50	DIABETES	-8.8990
51	DIABETES	-11.4934
52	DIABETES	-11.6011
53	DIABETES	-10.5907
54	DIABETES	-12.2495
55	DIABETES	-10.4093
56	DIABETES	-10.1302
57	DIABETES	-8.7694
58	DIABETES	-9.2478
59	DIABETES	-9.8326
60	DIABETES	-9.6406
61	DIABETES	-11.9578
62	DIABETES	-12.1825
63	DIABETES	-8.8980
64	DIABETES	-9.0345
65	HEALTHY	9.6250
66	HEALTHY	9.5341
67	HEALTHY	8.9414
68	HEALTHY	9.0173
69	HEALTHY	10.2362
70	HEALTHY	10.5067
71	HEALTHY	8.7871
72	HEALTHY	10.0172
73	HEALTHY	9.2227
74	HEALTHY	9.3548
75	HEALTHY	9.7580
76	HEALTHY	9.9200
77	HEALTHY	9.3763
78	HEALTHY	9.2069
79	HEALTHY	10.4042
80	HEALTHY	10.2012
81	HEALTHY	8.8216
82	HEALTHY	9.7322
83	HEALTHY	11.3844

FIG. 7C

84	HEALTHY	9.7765
85	HEALTHY	10.2588
86	HEALTHY	9.5954
87	HEALTHY	9.7588
88	HEALTHY	9.8602
89	HEALTHY	9.5577
90	HEALTHY	10.0677
91	HEALTHY	9.5621
92	HEALTHY	10.4281
93	HEALTHY	11.0545
94	HEALTHY	9.3259
95	HEALTHY	10.0612
96	HEALTHY	10.3474
97	HEALTHY	9.2923
98	HEALTHY	9.6250
99	HEALTHY	9.5341
100	HEALTHY	8.9414
101	HEALTHY	9.0173
102	HEALTHY	10.2362
103	HEALTHY	10.5067
104	HEALTHY	8.7871
105	HEALTHY	10.0172
106	HEALTHY	9.2227
107	HEALTHY	9.3548
108	HEALTHY	9.7580
109	HEALTHY	9.9200
110	HEALTHY	9.3763
111	HEALTHY	9.2069
112	HEALTHY	10.4042
113	HEALTHY	10.2012
114	HEALTHY	8.8216
115	HEALTHY	9.7322
116	HEALTHY	11.3844
117	HEALTHY	9.7765
118	HEALTHY	10.2588
119	HEALTHY	9.5954
120	HEALTHY	9.7588
121	HEALTHY	9.8602
122	HEALTHY	9.5577
123	HEALTHY	10.0677
124	HEALTHY	9.5621
125	HEALTHY	10.4281

FIG. 7D

126	HEALTHY	11.0545
127	HEALTHY	9.3259
128	HEALTHY	10.0612

STATUS	E/I Ratio	SD	RMS-SD	TP	30:15 Ratio	NNmin SB	NNmin Standing	NNmax Standing
1DIABETES 1	1.1075	31.48	27.51	63.64	1.083	572	372	592
2HEALTHY	1.3966	110.76	52.63	1020.37	1.349	748	620	936

Figure 8: Test results for two exemplar patients.

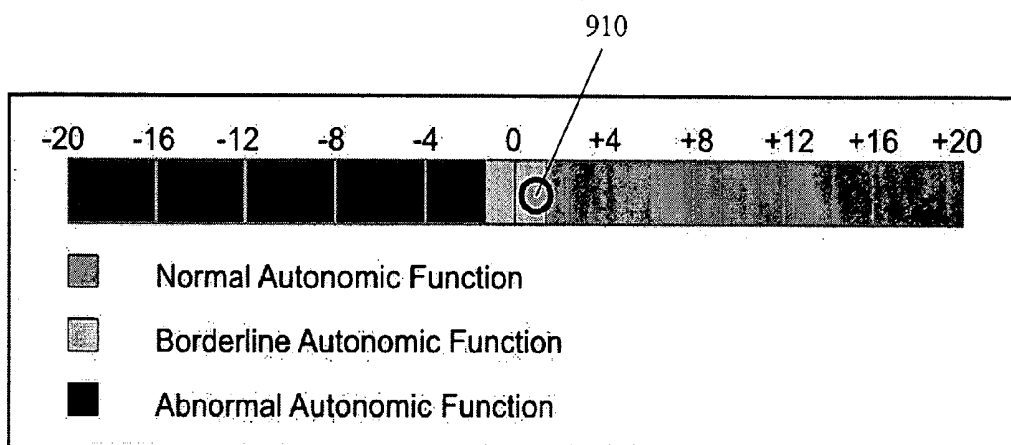

Figure 9: Exemplar graphical display of autonomic ranking for exemplar Patient2.

FIG. 10

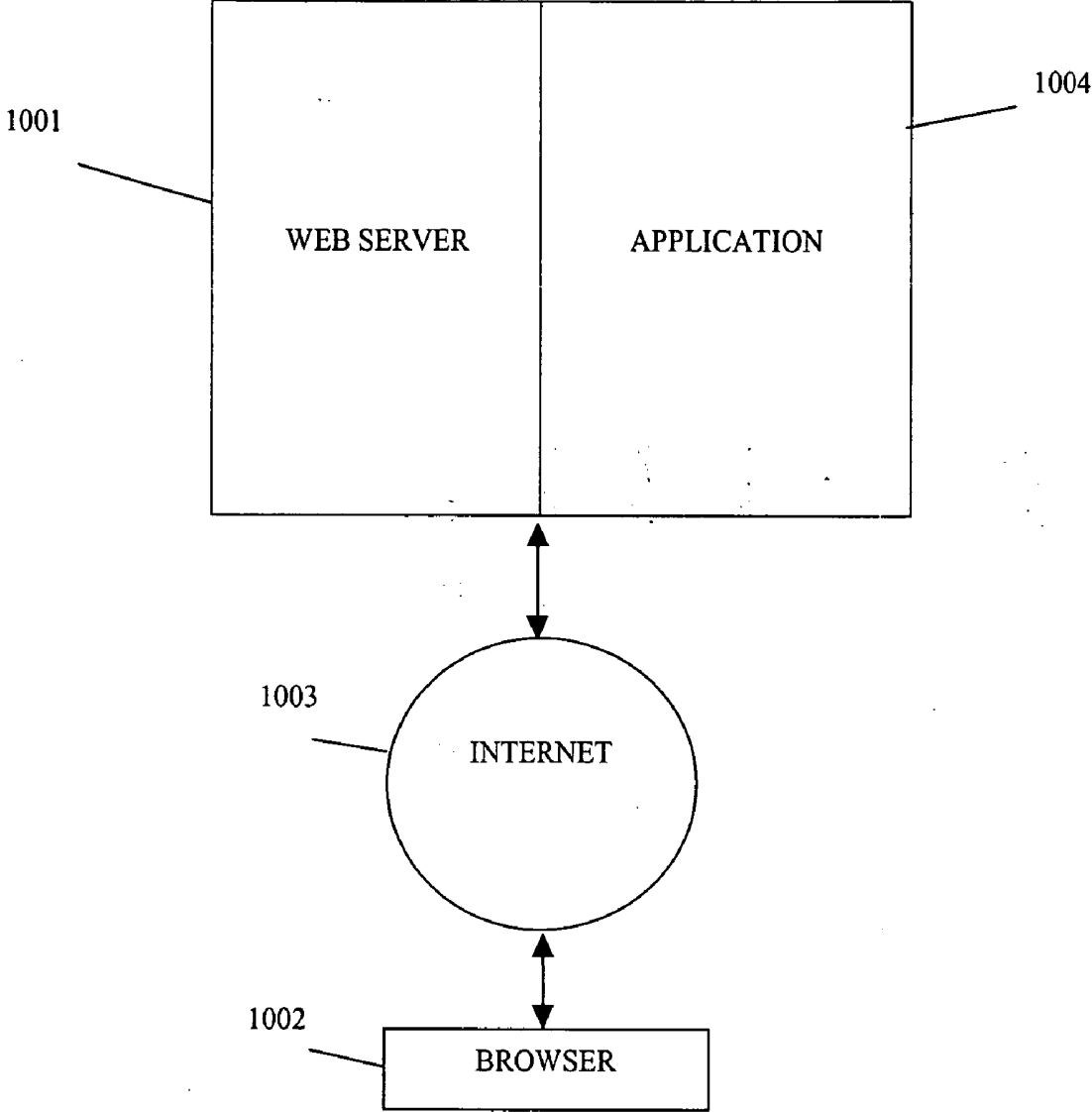

FIG. 11

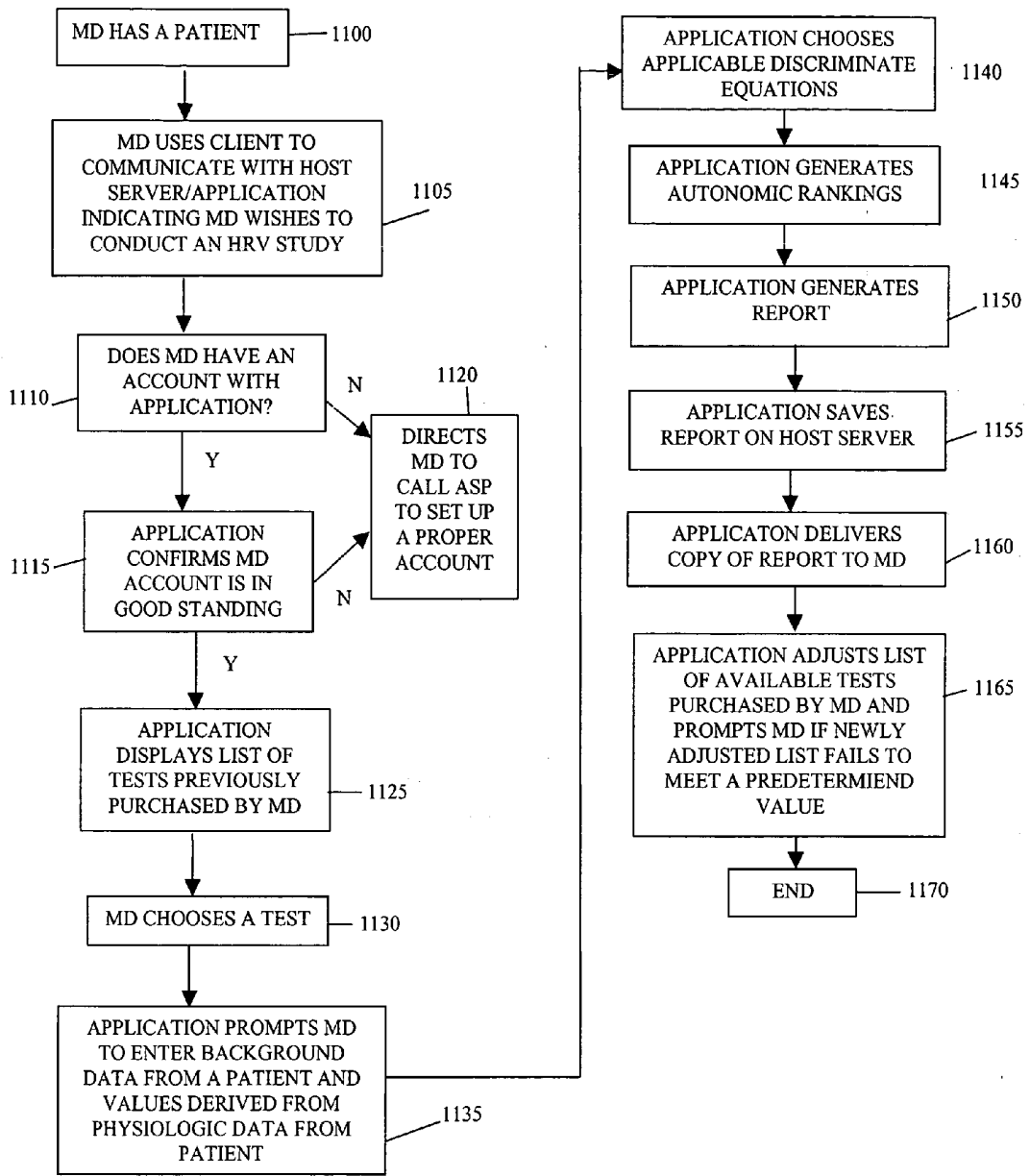

FIG. 12

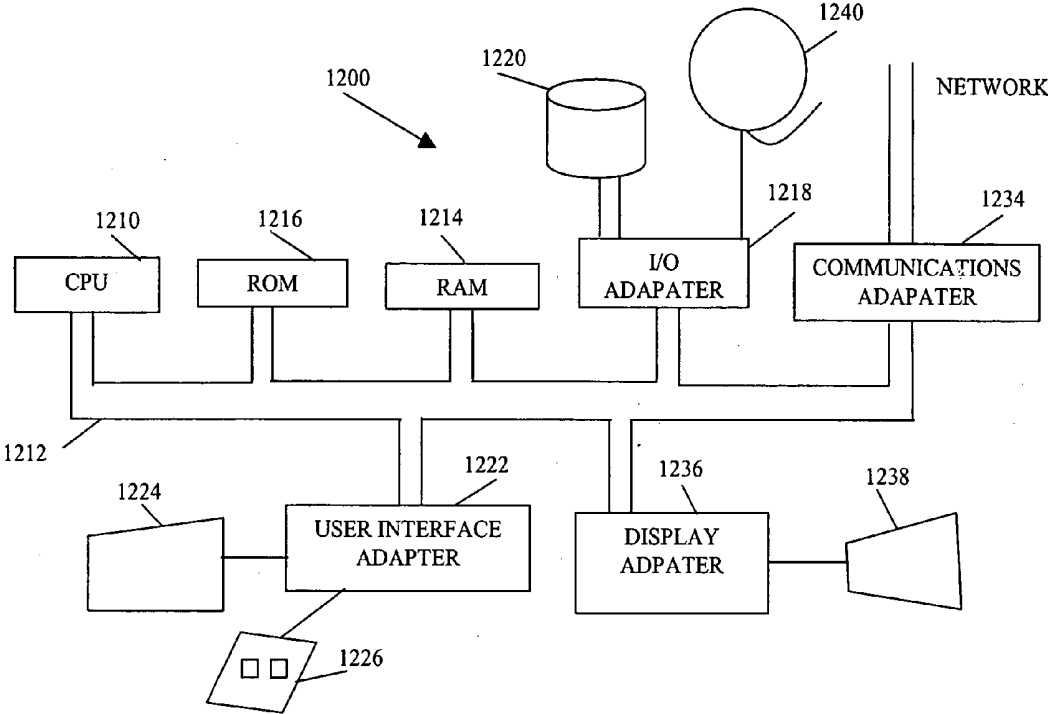

FIG. 13A

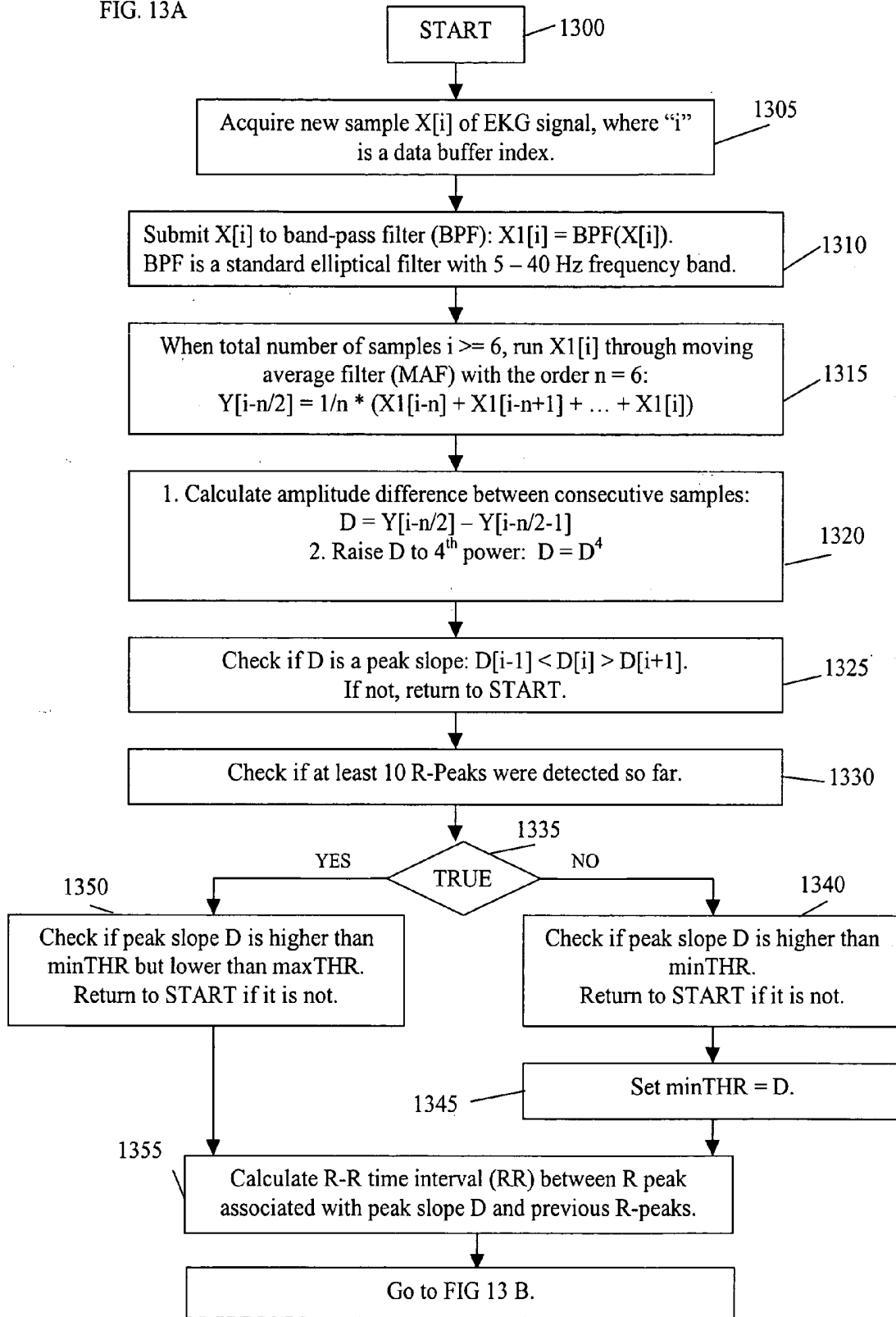
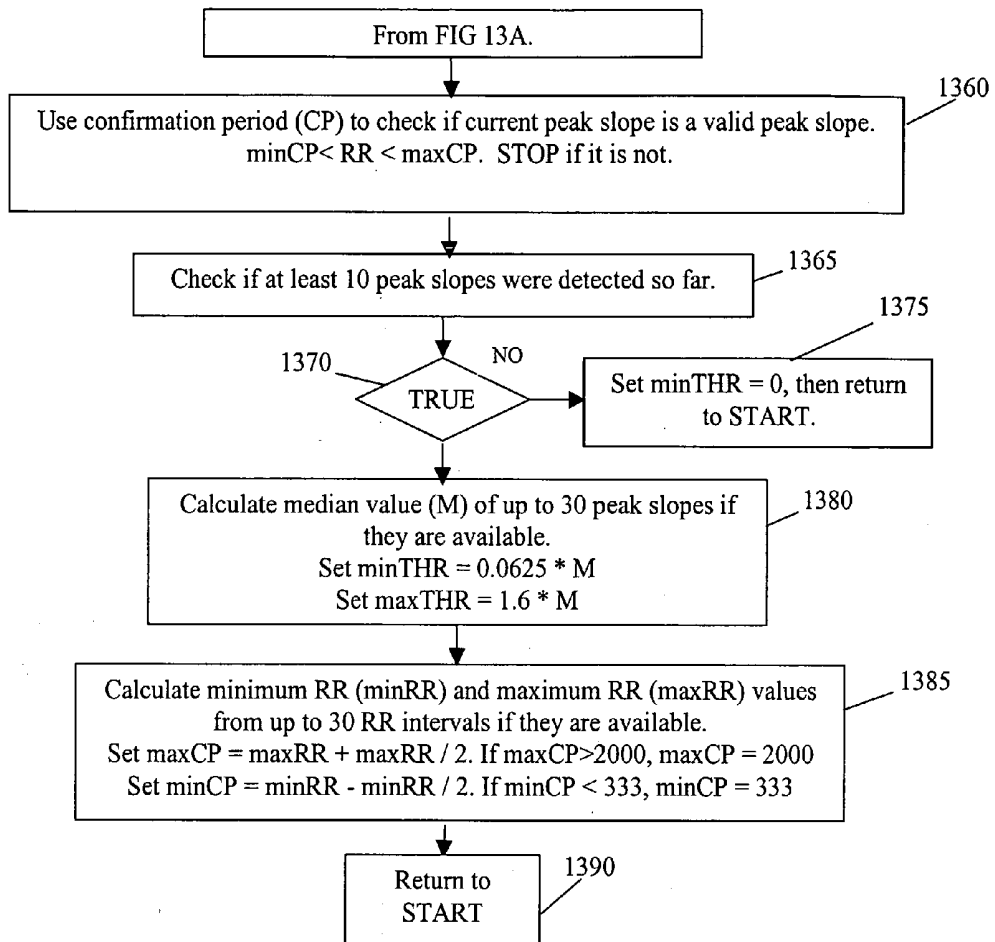

FIG. 13B



Initial test values:

Minimum threshold (minTHR) = 0

Maximum threshold (maxTHR) = maximum possible X value (ECG signal)

Minimum confirmation period (minCP) = 333 ms

Maximum confirmation period (maxCP) = 2000 ms

FIG. 14A

	STATUS	RMS-SD	TP	E/I Ratio	SD	30:15 Ratio	NNmin SB	NNmin Standing	NNmax Standing
1	DIABETES	50.93	380.94	1.1889	62.12	1.235	616	592	731.12
2	DIABETES	58.039	389	1.239	56.41	1.287	796	692	890.604
3	DIABETES	10.065	181.622	1.116	35.25	1.182	532	516	609.912
4	DIABETES	52.93	382.94	1.19	62.15	1.296	600	502	650.592
5	DIABETES	60.039	400	1.24	58	1.289	580	545	702.505
6	DIABETES	10.07	182	1.116	35.3	1.18	550	584	689.12
7	DIABETES	51.93	598	1.18	62	1.278	700	597	762.966
8	DIABETES	51.9	687	1.1889	62.12	1.269	730	587	744.903
9	DIABETES	58	220	1.239	56.41	1.287	680	578	743.886
10	DIABETES	10.065	182.678	1.116	35.25	1.182	578	514	607.548
11	DIABETES	52.93	648	1.19	62.15	1.247	592	640	798.08
12	DIABETES	60.039	247	1.24	58	1.289	658	658	848.162
13	DIABETES	10.07	182	1.116	35.3	1.181	612	632	746.392
14	DIABETES	51.93	378	1.18	62	1.236	623	647	799.692
15	DIABETES	59	268	1.22	61	1.28	684	694	888.32
16	DIABETES	10	181	1.114	35	1.18	724	555	654.9
17	DIABETES	11	182	1.125	36	1.188	689	532	632.016
18	DIABETES	51.91	770	1.1889	62.12	1.245	678	547	681.015
19	DIABETES	59	381	1.239	56.41	1.287	625	568	731.016
20	DIABETES	10.065	184.678	1.116	35.25	1.182	624	512	605.184
21	DIABETES	52.93	299	1.19	62.15	1.278	599	598	764.244
22	DIABETES	60.039	384	1.24	58	1.289	726	599	772.111
23	DIABETES	10.07	182	1.116	35.3	1.188	720	547	649.836
24	DIABETES	51.93	378	1.18	62	1.284	580	532	683.088
25	DIABETES	51.94	780	1.1889	62.12	1.296	594	587	760.752
26	DIABETES	59.1	380	1.239	56.41	1.287	577	514	661.518
27	DIABETES	10.065	182.6	1.116	35.25	1.182	588	597	705.654
28	DIABETES	52.93	278	1.19	62.15	1.281	645	520	666.12
29	DIABETES	60.039	155	1.24	58	1.289	625	600	773.4
30	DIABETES	10.07	182	1.116	35.3	1.1897	619	620	737.614
31	DIABETES	51.93	794	1.18	62	1.269	684	573	727.137
32	DIABETES	59	382	1.223	47	1.28	675	610	780.8
33	DIABETES	25.25	379	1.123	45.23	1.189	600	598	764.244
34	DIABETES	43.15	389	1.234	51.23	1.126	610	599	772.111
35	DIABETES	35.12	181	1.156	65.52	1.299	620	547	649.836
36	DIABETES	45.18	380	1.22	64.25	1.264	630	532	683.088
37	DIABETES	54.78	405	1.17	55.55	1.185	740	587	760.752
38	DIABETES	32.12	190	1.18	54.12	1.234	720	514	661.518
39	DIABETES	22.16	600	1.15	32.32	1.2	654	597	705.654
40	DIABETES	24.26	700	1.19	39.34	1.211	586	520	666.12
41	DIABETES	28.46	230	1.14	41.02	1.236	687	600	773.4
42	DIABETES	27.98	184	1.187	63.25	1.245	623	620	737.614
43	DIABETES	45.56	650	1.244	71.25	1.281	642	573	727.137
44	DIABETES	35.46	250	1.211	70.02	1.263	649	610	780.8

FIG. 14B

	STATUS	RMS-SD	TP	E/I Ratio	SD	30:15 Ratio	NNmin SB	NNmin Standing	NNmax Standing
45	DIABETES	37.48	190	1.201	34.56	1.245	687	640	798.08
46	DIABETES	35.24	389	1.222	45.12	1.278	702	658	848.162
47	DIABETES	33.25	267	1.189	47.18	1.256	711	632	746.392
48	DIABETES	21.24	182	1.245	43.26	1.212	623	647	799.692
49	DIABETES	20.21	182	1.248	43.46	1.246	645	694	888.32
50	DIABETES	36.38	779	1.188	55.23	1.239	690	592	731.12
51	DIABETES	47.56	390	1.177	41.95	1.248	689	692	890.604
52	DIABETES	35.47	187	1.165	33.28	1.284	674	516	609.912
53	DIABETES	24.22	320	1.128	39.15	1.264	598	502	650.592
54	DIABETES	54.24	398	1.1364	41.23	1.234	578	545	702.505
55	DIABETES	51.2	399	1.211	45.11	1.245	534	584	689.12
56	DIABETES	47.45	350	1.239	36.31	1.284	596	597	762.966
57	DIABETES	24.35	790	1.237	32.15	1.267	578	587	744.903
58	DIABETES	24.26	394	1.235	31.24	1.234	569	578	743.886
59	DIABETES	27.28	200	1.236	30.12	1.247	610	514	607.548
60	DIABETES	27.39	230	1.237	34.69	1.236	623	640	798.08
61	DIABETES	31.29	190	1.122	38.15	1.248	627	658	848.162
62	DIABETES	31.89	185	1.126	39.12	1.239	638	632	746.392
63	DIABETES	32.56	845	1.238	41.32	1.247	659	647	799.692
64	DIABETES	33.46	425	1.24	41.36	1.294	645	694	888.32
65	HEALTHY	119.14	2300	1.68	153.9755	1.568	650	524	821.632
66	HEALTHY	120	2000	1.681	153.8888	1.5988	620	580	927.304
67	HEALTHY	63.34	1500.03	1.603	138.509	1.5	556	600	900
68	HEALTHY	86.78	3331.34	1.62	141.3	1.45	600	690	1000.5
69	HEALTHY	121	2589	1.688	154	1.599	500	700	1119.3
70	HEALTHY	65	3244	1.62	139	1.555	777	710	1104.05
71	HEALTHY	125	2999	1.611	158	1.618	775	540	873.72
72	HEALTHY	70.8	3400	1.59	152	1.46	745	789	1151.94
73	HEALTHY	70.7	2498.7	1.57	151	1.468	510	820	1203.76
74	HEALTHY	119.18	1902.56	1.685	153.8812	1.5562	630	520	809.224
75	HEALTHY	63.34	2500	1.603	138.509	1.5	614	546	819
76	HEALTHY	86.78	3331.34	1.65	141.3	1.45	514	652	945.4
77	HEALTHY	126	2456	1.688	154	1.599	800	547	874.653
78	HEALTHY	65	2220	1.62	135	1.551	700	842	1305.942
79	HEALTHY	121	3125	1.611	170	1.618	625	700	1132.6
80	HEALTHY	70.8	2400	1.59	152	1.52	645	582	884.64
81	HEALTHY	119.111	1902.56	1.689	153.9456	1.512	678	664	1003.968
82	HEALTHY	63.34	2899	1.603	138.509	1.5	698	657	985.5
83	HEALTHY	86.78	3331.34	1.7	141.3	1.55	659	698	1081.9
84	HEALTHY	128	2698	1.688	154	1.599	600	621	992.979
85	HEALTHY	65	2487	1.62	140	1.552	645	675	1047.6
86	HEALTHY	129	2789	1.611	171	1.618	687	691	1118.038
87	HEALTHY	70.8	2777	1.59	152	1.46	698	701	1023.46
88	HEALTHY	70.7	2498.7	1.57	152	1.54	589	750	1155
89	HEALTHY	119.119	2902.35	1.675	153.9999	1.522	584	710	1080.62

FIG. 14C

	STATUS	RMS-SD	TP	E/I Ratio	SD	30:15 Ratio	NNmin SB	NNmin Standing	NNmax Standing
90	HEALTHY	63.34	3458.59	1.603	138.509	1.5	678	760	1140
91	HEALTHY	86.78	3331.34	1.61	141.3	1.56	594	754	1176.24
92	HEALTHY	119	2945.36	1.688	154	1.599	678	589	941.811
93	HEALTHY	65	3215.25	1.62	141	1.554	645	623	968.142
94	HEALTHY	122.356	3000.02	1.611	159	1.618	635	547	885.046
95	HEALTHY	70.8	2400	1.59	152	1.49	600	594	885.06
96	HEALTHY	121	4056	1.611	160	1.618	620	620	1003.16
97	HEALTHY	121	2932.569	1.611	158	1.618	580	623	1008.014
98	HEALTHY	119.14	2300	1.68	153.9755	1.568	650	524	821.632
99	HEALTHY	120	2000	1.681	153.8888	1.5988	620	580	927.304
100	HEALTHY	63.34	1500.03	1.603	138.509	1.5	556	600	900
101	HEALTHY	86.78	3331.34	1.62	141.3	1.45	600	690	1000.5
102	HEALTHY	121	2589	1.688	154	1.599	500	700	1119.3
103	HEALTHY	65	3244	1.62	139	1.555	777	710	1104.05
104	HEALTHY	125	2999	1.611	158	1.618	775	540	873.72
105	HEALTHY	70.8	3400	1.59	152	1.46	745	789	1151.94
106	HEALTHY	70.7	2498.7	1.57	151	1.468	510	820	1203.76
107	HEALTHY	119.18	1902.56	1.685	153.8812	1.5562	630	520	809.224
108	HEALTHY	63.34	2500	1.603	138.509	1.5	614	546	819
109	HEALTHY	86.78	3331.34	1.65	141.3	1.45	514	652	945.4
110	HEALTHY	126	2456	1.688	154	1.599	800	547	874.653
111	HEALTHY	65	2220	1.62	135	1.551	700	842	1305.942
112	HEALTHY	121	3125	1.611	170	1.618	625	700	1132.6
113	HEALTHY	70.8	2400	1.59	152	1.52	645	582	884.64
114	HEALTHY	119.111	1902.56	1.689	153.9456	1.512	678	664	1003.968
115	HEALTHY	63.34	2899	1.603	138.509	1.5	698	657	985.5
116	HEALTHY	86.78	3331.34	1.7	141.3	1.55	659	698	1081.9
117	HEALTHY	128	2698	1.688	154	1.599	600	621	992.979
118	HEALTHY	65	2487	1.62	140	1.552	645	675	1047.6
119	HEALTHY	129	2789	1.611	171	1.618	687	691	1118.038
120	HEALTHY	70.8	2777	1.59	152	1.46	698	701	1023.46
121	HEALTHY	70.7	2498.7	1.57	152	1.54	589	750	1155
122	HEALTHY	119.119	2902.35	1.675	153.9999	1.522	584	710	1080.62
123	HEALTHY	63.34	3458.59	1.603	138.509	1.5	678	760	1140
124	HEALTHY	86.78	3331.34	1.61	141.3	1.56	594	754	1176.24
125	HEALTHY	119	2945.36	1.688	154	1.599	678	589	941.811
126	HEALTHY	65	3215.25	1.62	141	1.554	645	623	968.142
127	HEALTHY	122.356	3000.02	1.611	159	1.618	635	547	885.046
128	HEALTHY	70.8	2400	1.59	152	1.49	600	594	885.06

Fig. 15A

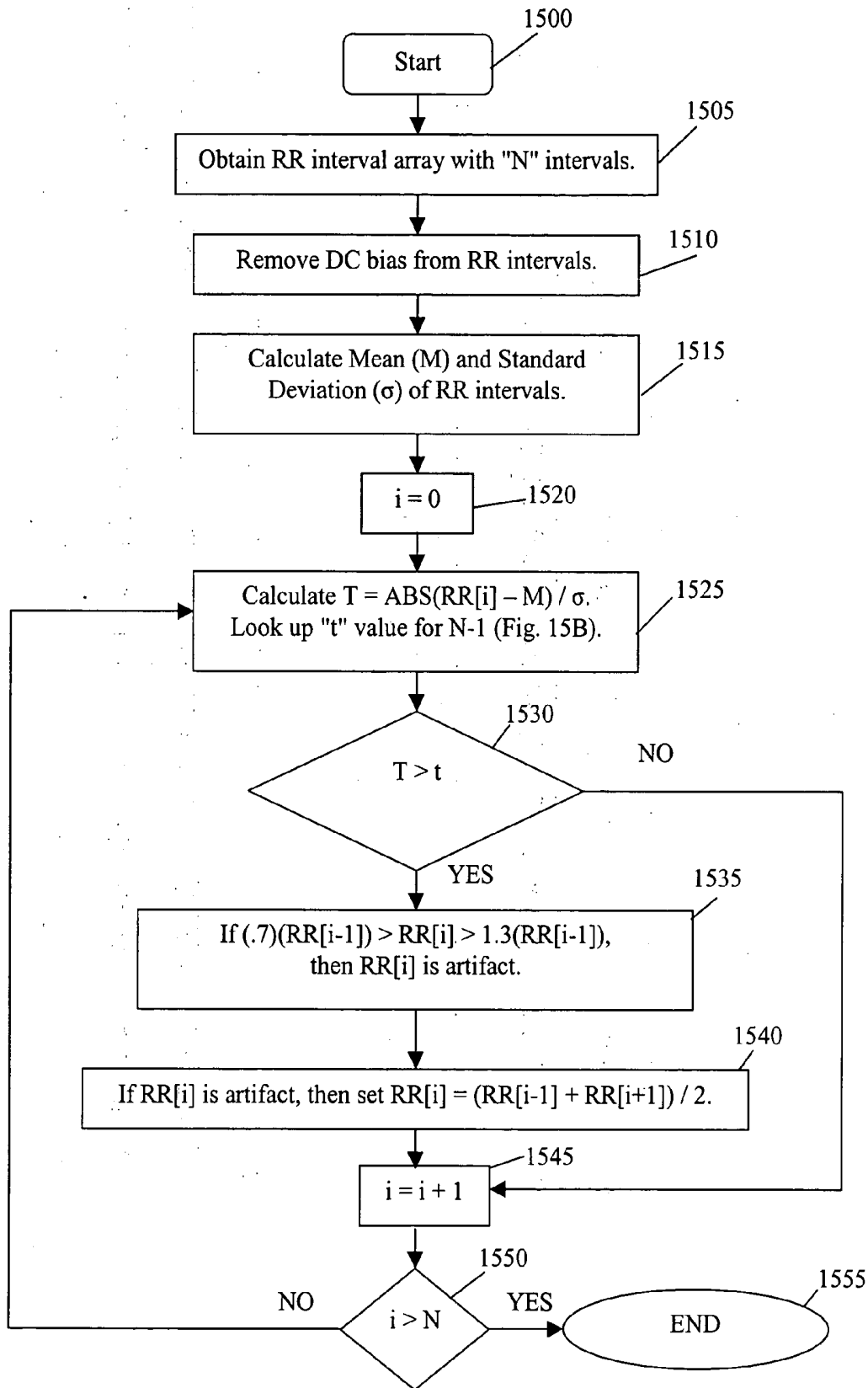

Fig. 15B

N-1	t
5	3.04
6	2.78
7	2.62
8	2.51
9	2.43
10	2.37
11	2.33
12	2.29
13	2.26
14	2.24
15	2.22
16	2.20
17	2.18
18	2.17
20	2.145
25	2.105
30	2.079
35	2.061
40	2.048
45	2.038
50	2.030
60	2.018
70	2.009
80	2.003
90	1.998
100	1.994
1000	1.960

FIG. 16A

	Parameter Name	HRV Test	Description
1	30:15 Ratio	Orthostatic	30:15 Ratio (ratio between the maximum HR recording during the first 15 seconds of standing to the minimum HR recorded during first 30 seconds of standing)
2	NNmin Standing	Orthostatic	Minimum NN (ms)
3	NNmax Standing	Orthostatic	Maximum NN (ms)
4	Tmax	Orthostatic	Time to achieve maximum HR after standing up (ms)
5	Trec	Orthostatic	Time to recover HR to 75% of its baseline level (ms)

FIG. 16B

	Parameter Name	HRV Test	Description
1	E/I Ratio	Slow Metronomic Breathing	Mean ratio of HR max/HR min in each consecutive breath cycle (also known as E/I Ratio)
2	SD	Slow Metronomic Breathing	Standard deviation of NN intervals
3	NNmin SB	Slow Metronomic Breathing	Minimum NN (ms)
4	NNmax SB	Slow Metronomic Breathing	Maximum NN (ms)
5	VARmax	Slow Metronomic Breathing	Maximum Variance of NN between consecutive breath cycles
6	VARmean	Slow Metronomic Breathing	Mean Variance of NN between consecutive breath cycles

FIG. 16C

	Parameter Name	HRV Test	Description
1	RMS-SD	Short-term resting HRV	Root mean square of the differences in successive NN intervals
2	NN	Short-term resting HRV	Mean NN interval (NN)
3	SDNN	Short-term resting HRV	Standard deviation of NN intervals

FIG. 16D

	Parameter Name	HRV Test	Description
1	TP	Short-term resting HRV	Power spectrum for a fourth frequency range that comprises the first predetermined frequency range, the second predetermined frequency range and the third predetermined frequency range
2	LFnorm	Short-term resting HRV	(LF):(TP-VLF) ratio
3	HFnorm	Short-term resting HRV	(HF):(TP-VLF) ratio
4	LF/HF	Short-term resting HRV	LF:HF ratio
5	VLF	Short-term resting HRV	Power spectrum for a first predetermined frequency range
6	LF	Short-term resting HRV	Power spectrum for a second predetermined frequency range
7	HF	Short-term resting HRV	Power spectrum for a third predetermined frequency range

METHOD AND APPARATUS FOR MEASUREMENT OF AUTONOMIC NERVOUS SYSTEM FUNCTION

BACKGROUND INFORMATION

[0001] 1. Technical Field

[0002] The present invention relates to apparatuses and methods for measuring autonomic nervous system function.

[0003] 2. Description of the Related Art

[0004] The autonomic nervous system (ANS) is primarily responsible for the fine-tuned regulation of many human organs and systems. An individual whose autonomic nervous system correctly regulates such organs and systems is said to have good autonomic function. Improper autonomic function may be referred to as autonomic dysfunction, which can be the result of autonomic neuropathy (AN). AN can result in improper regulation of organs and systems, which in turn may lead to the malfunction of those organs and systems. AN is often associated with a number of disorders such as diabetes and coronary artery disease. In fact, the last two decades have witnessed the recognition of a significant relationship between AN and cardiovascular mortality, including sudden cardiac death. Thus, testing for AN may be a useful health monitoring tool.

[0005] One way to test for AN is by evaluating how well the ANS regulates the heart through a "heart rate variability" (HRV) study. In such a study, a patient performs certain breathing tests, which, in a person with a properly functioning ANS, will cause fluctuations in the patient's heart rate (HR). As AN increases, HRV decreases. HRV is a measurement of the fluctuation of R-R intervals in a patient's electrocardiogram (ECG). The R-R interval is the distance between R peaks in a QRS complex. Detection of R-R intervals may be achieved by various methods such as a simple threshold technique or statistical method, both of which are known to those of ordinary skill in the art.

[0006] HRV testing is useful for more than determining whether a patient has AN. For example, HRV testing may be used to monitor disease progression as a function of changes in autonomic function. HRV testing may also be used to evaluate a patient's response to a prescribed treatment for an autonomic disorder. Other applications for HRV testing include: general health screening, diabetic neuropathy assessment, pre-condition cardiac health screening, post-myocardial infarction risk assessment and evaluation, drug studies including the relationship between certain drug dosages and AN function, and stress measurement of, for example, ADHD children.

[0007] Several clinical tests, known to those of ordinary skill in the art, help physicians or clinicians measure HRV. Examples of such tests are the Slow Metronomic Breathing test, Valsalva test and Orthostatic test. Each test measures certain HRV parameters, subsets of which may indicate whether a patient is predisposed for, or afflicted with, AN and one or more of its related maladies such as diabetes. These three tests will now be addressed.

[0008] 1. Slow Metronomic Breathing Test

[0009] The Slow Metronomic Breathing test is designed to assess the parasympathetic branch of the ANS. As those of ordinary skill in the art will appreciate, during the test the patient breathes deeply and evenly, in a supine position, at

six breaths per minute. The exclusion of any events that could alter spontaneous breathing, such as speech or coughing, should be limited. To foster patient compliance with the prescribed breathing regimen, the patient should breathe for one minute following pacer movements, similar to a metronome, which may be displayed on a computer screen.

[0010] The breathing regimen described above helps assess ANS function because parasympathetic regulation of the heart rhythm relies on different types of receptors located in the lungs. These receptors are taxed by the deep breathing performed during the Metronomic test. More specifically, chemoreceptors detect concentrations of CO₂ and H⁺ ions in the arterial blood, which change as one breathes. Chemoreceptors send signals to the brain that are representative of the concentration of these elements. The brain may then regulate the heart, by adjusting the heart rate, to achieve these reported concentration levels. Mechanoreceptors, unlike chemoreceptors, react to changes of air pressure within a patient's airways. Breathing, and especially heavy breathing, creates changes in intrathoracic pressure which are then sensed by mechanoreceptors. This results in a change in blood pressure. The baroreflex mechanism then causes changes in heart rate. These changes in pressure produce signals that are sent along afferent fibers from the mechanoreceptors to the brain stem. In summary, changes in breathing can affect both chemoreceptors and mechanoreceptors, both located in the lungs, which in turn communicate with the brain to potentially illicit a change in HR for a person with "good HRV."

[0011] The HRV parameters or measurements measured in the Metronomic test may include one or more of the measurements found in **FIG. 16B**. The parameters are calculated on "normal-to-normal" inter-beat intervals (NN intervals), which are R-R intervals calculated on beats caused by normal heart contractions paced by sinus node depolarization.

[0012] 2. The Orthostatic Test

[0013] Like the Metronomic test, the Orthostatic test is used to evaluate the effect of parasympathetic regulation on HR. Therefore, the test provides a good indication of autonomic function and HRV. More specifically, the Orthostatic test evaluates how a change in body position affects heart rate. The patient is instructed to lie down in an idle, relaxed, supine position. After a minute of recording ECG signals, the patient stands up while avoiding any rapid movements. The patient remains standing for another minute. The patient's heart rhythm is monitored continuously while the patient lies down and stands up. HR monitoring should continue until a stationary state in HR is detected.

[0014] The Orthostatic test helps evaluate autonomic function because it taxes a set of regulatory mechanisms that support parasympathetic regulation of the heart rhythm. More specifically, blood mass redistribution takes place when a patient changes from a supine position to a standing position. The baroreceptors situated in the aortic arch and carotid nodes perceive this change in blood distribution and communicate the change to the brain via afferent fibers. These communications cause an increase in the activation of sympathetic efferent fibers and a decrease in activation of parasympathetic efferent fibers. These efferent fibers then transmit regulatory instructions from the brain down the sympathetic and parasympathetic nerves pathways. The

tonus of the arteries in the carotid sinus is consequently decreased causing activation of the adrenergic receptors of blood vessel walls and perivascular tissues. Thus, the body shift causes a sympathetic positive chronotropic effect. Concurrently, when the patient changes positions, an increase of muscular activity takes place thereby causing an increase in blood delivery from the extremities. The sympathetic effects are increased and sustained during the post-stimuli period to support the vertical posture. So, blood pressure gradually increases due to activation of the sympathetic NS. The increase in blood pressure causes stimulation of the parasympathetic NS. This stimulation occurs via the baroreflex mechanism and is followed by a decrease in HR. In summary, changing positions taxes the ANS, which should result in a change in heart rate for those patients with good HRV.

[0015] The HRV parameters or measurements measured in the Metronomic test may include one or more of the measurements found in FIG. 16A. The parameters are calculated on "normal-to-normal" inter-beat intervals (NN intervals), which are R-R intervals calculated on beats caused by normal heart contractions paced by sinus node depolarization.

[0016] 3. The Valsalva Test

[0017] The Valsalva test also helps assess autonomic function. The Valsalva test commences with the patient in the supine position with his head slightly elevated. The patient then strains by blowing into a mouthpiece until a 40 mm Hg pressure is obtained for 15 seconds. Following cessation of the Valsalva strain, the patient relaxes and breathes at a normal rate. The ECG is monitored during the strain and at 30-45 seconds afterwards. Maximum and minimum heart rates are obtained respectively at about one second after cessation of strain and then 15-20 seconds later. This process is repeated three times and the largest heart rate ratio is considered the best reflection of autonomic function. The end result of the test is a measurement called the Valsalva ratio. The Valsalva ratio ("VR"), which constitutes a HRV parameter, is the ratio of the longest R-R interval to the shortest R-R interval at one second and 15-20 seconds after the Valsalva maneuver is completed. Again, the methods for performing the Metronomic, Orthostatic and Valsalva tests are known to those of ordinary skill in the art.

[0018] While the methods for performing the Metronomic, Orthostatic and Valsalva tests produce valuable information regarding autonomic function, prior art methods and equipment fail to take full advantage of the available information. For instance, in the prior art, normative databases for HRV values are not created and maintained. As an illustration, the prior art does not attempt to determine normal VARmax values for patients according to such diverse factors as race, age, smoking history and gender. Consequently, the VARmax value of a black, 30-year old, non-smoking man is often compared with that of a 30-year old, white woman who has smoked for 10 years. Doing so may lead to an inaccurate assessment of the male patient's autonomic function. Furthermore, the prior art does not attempt to link certain factors such as race, age and VARmax value with a risk factor for contracting, for example, hypertension. An additional limitation in the prior art is the inability to provide normative databases that expand, and whose accuracy is refined as HRV studies continue to be performed. Finally, the prior art requires expensive, complicated and burden-

some HRV testing equipment that many non-specialists are unlikely to use. As a result, AN associated maladies, such as heart disease and diabetes, are not assessed as well as possible because the vast majority of clinicians do not possess these complex tools.

[0019] Therefore, a method and apparatus for measuring autonomic nervous system function is needed that can help patients gain early notice when they are at risk for developing an illness forecasted or indicated by poor autonomic function. In addition, a need exists for specific normative databases that provide targeted HRV information that focuses on both demographic and health factors. Such a normative database should help discern HRV patterns to allow clinicians to better assess potential health issues for patients. The normative database should continue to expand and provide more valuable forecasting and assessment tools as HRV studies are conducted over time. Finally, a need exists for HRV testing which is available through an Application Service Provider model so practitioners need not invest heavily in sophisticated equipment that must be updated regularly. Such testing capabilities would become a powerful tool in the clinician's hands for early detection of various medical problems before those maladies show any clinical manifestation. Furthermore, such capabilities would better allow health care providers to assess progress or deterioration in a patient's previously assessed autonomic dysfunction.

SUMMARY DESCRIPTION

[0020] In one embodiment of the invention, background data from a population of patients is obtained. The population of patients may be comprised of patients with both normal and abnormal autonomic function. Then, the invention may receive ECG data from the same population of patients. HRV parameters such as NNmin SB and SD may be measured from the ECG data. Afterwards, discriminant analysis may be performed on the HRV parameters and background data to determine discriminant equations, wherein each discriminant equation discriminates between patients with normal and abnormal autonomic function. For instance, patterns may be identified whereby certain HRV parameter measurements, when combined with certain background information, such as race and gender, may distinguish between individuals with early signs of diabetes and those without such signs. After these equations are developed, new patients may be tested. Each new patient provides background data and HRV data. Then, the invention may select, from among the discriminant equations it has previously developed from the data from the population of patients, only those equations that pertain to the particular patient being tested. Consequently, data from a 20 year old black woman may be compared to other 20 year old black women, each afflicted with a different malady. The new patient's HRV data could then be input into the selected equations to provide autonomic rankings that are indicative of the new patient's autonomic function. In one embodiment of the invention, the background and HRV data from each new patient may be added to the same information that exists for the population of patients thereby creating increasingly larger normative data sets from which future patients' autonomic function can be more accurately assessed.

[0021] In an alternative embodiment of the invention, a method for assessing autonomic performance concerns an

application for storing a population data set on a server. The population data set may be comprised of physiologic data and background data received from a population of patients wherein the population of patients is comprised of patients with abnormal autonomic function and patients with normal autonomic function. The application is operated on the server by an application service provider ("ASP"). The application determines a first discriminant equation that discriminates between the patients with abnormal autonomic function and the patients with normal autonomic function. A user may access the application with a browser over a communications network such as the Internet. The application may receive background data from a new patient and select one or more appropriate discriminant equations. The application may send the selected discriminant equations to the user's client terminal. The client terminal may then enter physiologic data from the new patient into the selected discriminant equations to produce autonomic rankings. The autonomic rankings are indicative of the new patient's autonomic function. The client terminal may then send the autonomic ranking and the physiologic data to the application. The application may use this information to determine additional discriminant equations.

[0022] Yet another embodiment of the invention entails a method of identifying an R-wave of an ECG signal. The method comprises receiving an ECG signal from a patient and sampling the ECG signal at a predetermined sampling rate to obtain a first sample, a second sample, a third sample and a fourth sample. The samples are then filtered and the slopes between the different samples are calculated. The different slopes are then compared until a maximum slope is located that exceeds a minimum threshold value and is less than a maximum threshold value.

[0023] In still another embodiment of the invention, a method for assessing autonomic function is concerned whereby a first set of ECG data is received from a patient. The first set of ECG data may have been recorded while the patient was in a substantially reclined position. The first set of ECG data is then measured to obtain a first set of HRV parameters comprised of one or more of the following HRV parameters: RMS-SD, TP, LFnorm, HFnorm, LF/HF, NN, SDNN, VLF, LF and HF. A second set of ECG data is received from the patient wherein the second set of ECG data was recorded pursuant to one or more of the following HRV tests: Orthostatic test, Metronomic test and Valsalva test. A second set of ECG data is then measured to obtain a second set of HRV parameters that are related to the Orthostatic test, Metronomic test and/or Valsalva test. Finally, the embodiment evaluates the first set of HRV parameters in conjunction with the second set of HRV parameters to evaluate the patient's autonomic function.

[0024] The foregoing has outlined rather broadly the features of the present invention in order that the detailed description of the invention that follows may be better understood. Additional features and advantages of the invention will be described hereinafter, which form the subject of the claims of the invention.

BRIEF DESCRIPTION OF THE DRAWINGS

[0025] For a more complete understanding of the present invention, and the advantages thereof, reference is now made to the following description taken in conjunction with the accompanying drawings, in which:

[0026] FIG. 1 is a flow diagram illustrating a method for measurement of autonomic nervous system function in one embodiment of the invention.

[0027] FIG. 2 is an example of a questionnaire concerning background information from a patient.

[0028] FIG. 3 is an example of a questionnaire concerning patient health information.

[0029] FIG. 4 is a block diagram illustrating a computer network for performing the processes of an embodiment of the invention.

[0030] FIG. 5 is a block diagram illustrating an exemplar data acquisition device in an embodiment of the invention.

[0031] FIGS. 6A-8 are examples of a normative database in an embodiment of the invention.

[0032] FIG. 9 is an example of a graphic display in an embodiment of the invention.

[0033] FIG. 10 is a block diagram that illustrates the modules of an embodiment of the invention.

[0034] FIG. 11 is a flow diagram illustrating the sequence of operations that may be performed in accordance with an embodiment of the present invention that uses an ASP model.

[0035] FIG. 12 is a data processing system that may be used for implementing various embodiments of the present invention.

[0036] FIGS. 13A-13B are flow diagrams illustrating the sequence of operations that may be performed in accordance with an embodiment of the present invention that concerns ECG analysis.

[0037] FIGS. 14A-C are examples of a normative database in an embodiment of the invention.

[0038] FIGS. 15A-B comprise a flow diagram, and accompanying table, illustrating a sequence of operations concerning ECG analysis that may be performed in accordance with an embodiment of the present invention.

[0039] FIGS. 16A-D are tables illustrating examples of HRV parameters in one embodiment of the invention.

DETAILED DESCRIPTION

[0040] 1. Acquire Background Data from Patient

[0041] FIG. 1 illustrates a method for measurement of autonomic nervous system function. The method begins in step 100. In step 105, background data is obtained from a patient. Such data may include, for example, age, height, weight, gender, race, smoker status and health status. FIG. 2 illustrates exemplar questions regarding the patient's background information. FIG. 3 illustrates exemplar questions regarding the patient's health history. FIGS. 2 and 3 are merely exemplar questionnaires and those of ordinary skill in the art will appreciate that more or less detailed questions or other questions can be asked. For example, the patient may be asked whether he has cancer, and if so, specifically what type of cancer. If any "medical conditions" are indicated, such as cancer, then the patient may be deemed, in a general sense, "unhealthy." If no "medical condition" is noted, the patient may be generally deemed "healthy." In addition, the clinician may make clinical observations

regarding the patient and include those observations along with the data supplied by the patient. For example, the clinician may note whether the patient presents with clinical symptoms of abnormal autonomic function such as tingling sensations in the patients arms or legs. If such symptoms are present, the clinician may note the patient has abnormal autonomic function.

[0042] 2. Conduct HRV Tests

[0043] Returning to **FIG. 1**, step **110** entails autonomic testing of the patient to obtain ECG data. Such testing may occur after background information has been received from the patient in step **105**. The patient may undergo provocative HRV tests such as the Metronomic Breathing test, Valsalva test and the Orthostatic test which were described in detail above. These tests are called provocative tests because a patient must provoke his nervous system, by standing up or breathing in a certain way, to produce results indicative of his HRV.

[0044] In addition to the provocative tests, a Short-Term Resting HRV test may also be used. The test is conducted over a five minute period while ECG data is recorded from a patient resting in the supine position. The patient breathes normally and in a non-provoked manner. For example, he does not time his breathing as is the case in the Metronomic test. Furthermore, he does not exhale forcefully in an effort to reach a certain air pressure as is the case in the Valsalva test. Therefore, specialized spirometric equipment is not needed. Also, patients who cannot tolerate stressful provocative measures, for health reasons, can still undergo this HRV test.

[0045] The Short-Term Resting HRV test assesses the balance between the sympathetic and parasympathetic branches of the ANS. These aspects of the nervous system have an effect on autonomic function. Historically, this test was used in limited capacities in assessing autonomic function and HRV. The limited use was due, at least in part, to the complexity associated with deriving HRV parameters from the data produced by the test. Consequently, the Metronomic, Valsalva and Orthostatic tests were favored over using the Short-Term Resting HRV test. Furthermore, the prior art often taught that just a few parameters from the provocative tests were sufficient to assess autonomic function.

[0046] In one embodiment of the invention, the Short-Term Resting HRV test is used in a novel way to assess autonomic function. The Short-Term Resting HRV test results are combined with results from one or more of the provocative tests to assess autonomic function. By so combining the results from Short-Term Resting HRV test and one or more provocative tests, autonomic function may be assessed in a more accurate way than is possible with the cursory prior art methods of testing autonomic function.

[0047] At least ten HRV parameters, existing in both the time and frequency domains, can be monitored in the Short-Term Resting HRV test. All of parameters are calculated on "normal-to-normal" inter-beat intervals (NN intervals), which are R-R intervals calculated on beats caused by normal heart contractions paced by sinus node depolarization. All time-domain HRV parameters are derived directly from NN intervals recorded during the test. The frequency-domain HRV parameters are derived from the power spectral density (PSD) calculated by means of a Fast Fourier Transform (FFT).

[0048] As seen in **FIG. 16C**, the following is a list of definitions for the time-domain HRV parameters or measurements. First, Mean NN interval ("NN") is a mean inter-beat interval value averaged over the entire ECG recording and is measured in milliseconds. Second, SDNN ("SDNN") is a standard deviation of the NN intervals that is calculated from the square root of the variance of those intervals. Variance is the mathematical equivalent to the total power of the spectral analysis. Consequently, variance reflects all cyclic components of variability in a recorded series of NN intervals. The actual values of SDNN depend on the length of recording whereby the longer the recording is, the higher the SDNN values are. Thus, one should not compare SDNN values derived from ECG recordings of different lengths. SDNN is measured in milliseconds. Third, "RMS-SD" is the root mean square of the differences in successive NN intervals. This measure is an estimate of high-frequency variations of heart rate, derived from short term NN recordings, that reflects an estimate of parasympathetic regulation of the heart. RMS-SD is measured in milliseconds.

[0049] As seen in **FIG. 16D**, the following is a list of definitions for the frequency-domain HRV parameters or measurements. First, Total Power ("TP") is a short-term estimate of the total power of the power spectral density in the range of frequencies between 0 and 0.4 Hz. This measure reflects overall autonomic activity where sympathetic activity is a primary contributor. Total Power is calculated in milliseconds squared (ms^2). Second, Very Low Frequency ("VLF") is a band of power spectrum range between 0.0033 and 0.04 Hz. This measure is not well defined in terms of physiologic mechanisms that cause the VLF component of the power spectrum. Generally, this parameter indicates overall activity of various slow mechanisms of sympathetic function. VLF is calculated in milliseconds squared (ms^2). Third, Low Frequency ("LF") is a band of the power spectrum range between 0.04 and 0.15 Hz. This measure reflects both sympathetic and parasympathetic activity. Generally, the parameter is a strong indicator of sympathetic activity in long-term recordings. Parasympathetic influence is represented by LF when the respiration rate is lower than seven breaths per minute or while taking a deep breath. Thus, when the patient is in a state of relaxation with slow and even breathing, the LF values can be very high, indicating increased parasympathetic activity rather than an increase of sympathetic regulation. LF is calculated in milliseconds squared (ms^2). Fourth, High Frequency ("HF") is a band of the power spectrum range between 0.15 and 0.4 Hz. This measurement reflects parasympathetic (vagal) activity. HF is also known as a "respiratory" band because it corresponds to the NN variations caused by respiration. This phenomenon is known as respiratory sinus arrhythmia (RSA). Heart rate increases during inhalation and drops during exhalation. Slow, even breathing causes an increase in the amplitude of the HF peak on the power spectrum. High Frequency is calculated in milliseconds squared (ms^2). Fifth, LF/HF Ratio ("LF/HF") is the ratio between the power of Low Frequency and High Frequency bands. This measure indicates overall balance between sympathetic and parasympathetic systems. Higher values reflect domination of the sympathetic system while lower ones reflect domination of the parasympathetic system. When deep and even breathing occurs, however, the elevation of this parameter reflects an increase of parasympathetic regulation due to the effect of

RSA. LF/HF Ratio is calculated in normalized units. Sixth, Normalized Low Frequency (“LFnorm”) is the ratio between the absolute value of the Low Frequency and the difference between Total Power and Very Low Frequency. This measure minimizes any effect of changes in Very Low Frequency power and emphasizes changes in sympathetic regulation. Normalized LF is calculated in percentile units. Seventh, Normalized High Frequency (“HFnorm”) is the ratio between the absolute value of the High Frequency and the difference between Total Power and Very Low Frequency. This measure minimizes any effect of changes in Very Low Frequency power and emphasizes changes in parasympathetic regulation. Normalized HF is calculated in percentile units.

[0050] Those of ordinary skill in the art will appreciate that there are a number of alternative embodiments available which allow for patients to undergo HRV testing using other methodologies and parameters not specifically mentioned above, and that such embodiments are within the scope of the present invention.

[0051] 3. Recording Equipment

[0052] FIG. 4 illustrates equipment that may be used in one embodiment of the invention. The exemplar embodiment of the invention may comprise one or more testing units 405, doctor’s workstations 410 and an internet-based server 415. The testing unit 405 is used for conducting autonomic assessment tests. As illustrated in FIG. 5, the testing unit 501 may consist of a PDA 545 (personal digital assistant or handheld computer), utilizing Windows Mobile 2003 OS, or a Tablet PC, and an ECG/Pressure acquisition device (EPAD) 550. The EPAD 550 provides, for example, functionality to measure a single-channel ECG and airflow pressure. The EPAD 550 may have three input connectors to attach standard ECG lead wires 510, in an isolated fashion, with disposable pre-gelled snap electrodes. The three ECG electrodes are typically applied approximately one inch below the middle of both collarbones and mid anterior on the medial line at ribs six and eight. The EPAD 550 may utilize individual, replaceable, 0.060 Pin connector, AHA color-coded patient lead wires. The EPAD 550 may incorporate 10 bit resolution, or more, and a frequency response of 0.5 to 35 Hz. The ECG signal from ECG lead wires 510 is amplified by amplifier 525 and digitized via the analog-to-digital (A/D) converter 520 using, for example, a sample rate of 300 samples/second using methods known to those of ordinary skill in the art. Hypoallergenic hydrogel electrodes combined with Ag/AgCl sensors provide reliable tracings. An exemplar electrode is the Easytrode™, available from sEMG, 202 Providence Mine Rd., Ste. 202, Nevada City, Calif. 95959.

[0053] The EPAD 550 also has an input tip to connect to a spirometric mouthpiece 505, via flexible plastic tubing, for measuring airflow and pressure when breathing through the mouthpiece. The pressure signal from mouthpiece 505 is converted into electronic form via the pressure transducer 515 and is then digitized via the A/D converter 520 using methods known to those of ordinary skill in the art. The spirometric circuitry may provide for a flow range of +/-14 liters/second with a volume between 0 and 8 liters expressed in body temperature and pressure saturated with water vapor conditions (BTPS). The flow specifications may allow for the greater of +/-5% or 200 ml/sec for FEF 25%-75%

(forced expiratory flow) and the greater of +/-10% or 400 ml/sec for PEF (peak expiratory flow). The same circuitry may, in one embodiment of the invention, provide volume specifications that allow for the greater of +/-3% or 50 ml for forced vital capacity (FVC) and forced expiratory volume in one second (FEV1). Elevation correction should allow for elevations of 0 to 15,000 feet. Accuracy and BTPS conditions may comply with Am. Thoracic Society Standards from 1994.

[0054] The digitized ECG and pressure signals are coupled to the processor 530. Processor 530 may execute programming instructions by which a patient’s heart rate variability is analyzed in response to the measured physiological data and may take various forms, such as conventional microprocessors of a standard personal computer, workstation or other microprocessor-driven device. In one embodiment of the invention, the processor 530 is an INTEL-compatible microprocessor of IBM-compatible personal computers. The EPAD 550 may be implemented using a standard personal computer chassis with certain components (e.g., amplifier 525 and analog-to-digital (A/D) converter 520) provided in the form of circuit modules adapted for insertion into I/O ports of the computer. The memory 535 is coupled to the processor 530 and may include a Random Access Memory (RAM) for temporary data storage and/or a device with read/write access for permanent data storage, such as a hard drive. The memory 535 may be available to store physiological data until the data is transmitted to the PDA 545. This transmission may occur in numerous ways including wireless means observing the Bluetooth protocol. It will be appreciated by those of ordinary skill in the art that the techniques of the present invention may be implemented with various apparatuses, including both hardware and software. For example, the PDA 545 may receive previously recorded data from holter recordings. Doing so may allow HRV studies, such as the Short Term Resting HRV test, to be performed on previously recorded data. Because tests such as the Short Term Resting HRV test are non-provocative in nature, no respiration data is needed. Consequently, ECG studies, taken for reasons completely unrelated to HRV studies, may still be analyzed for HRV purposes. The PDA 545 may also receive data from implantable devices such as pacemakers or AICD’s. The devices may communicate with the PDA 545 in real time or may deliver ECG data upon interrogation by the PDA 545. Other examples of alternative HRV testing equipment include the Qmed Monitor nDx™, from Qmed Inc., and the ANScore System™, from Boston Medical Technologies, Inc.

[0055] The data may be transmitted from the EPAD 550 to the PDA 545, or directly to the doctor’s workstation 410. The doctor’s workstation 410, as shown in FIG. 4, utilizes software executing on, in one example, the Windows Me/2000/XP operating system. The software may be installed on any desktop or laptop computer that has USB connection capability and access to the Internet. The doctor’s workstation 410 software can be programmed to automatically acquire test data from the PDA 545 every time the PDA 545 is placed on its cradle, which is connected to the PC via the USB port. The workstation 410 allows for management of test data by facilitating the following: obtaining test data from the PDA 545, viewing and verifying test data, sending test data and/or patient data to the server 415, accessing normative databases and discriminant equations for HRV assessment from the server 415, as will be

discussed below, viewing and printing pre-formatted test reports, deleting test data and exporting test data to other locations. In one embodiment of the invention, the workstation **410** has at least a Pentium-II 350 MHz processor, 32 MB of RAM, video card with at least 800×600 High-Color resolution, 50 MB of free hard disk space and CD ROM drive. In other embodiments, the workstation **410** may be omitted whereby, for example, the testing unit **405** may communicate directly with the server **415**. In still other embodiments, the testing unit **405** may be combined with the doctor's workstation **410** into one portable unit, such as a tablet PC. The tablet PC may communicate with the server **415**.

[0056] The test evaluation server **415** may be an internet server that provides multi-user connection capability. The normative databases and discriminant functions, to be addressed more thoroughly below, may be stored on the server **415** or alternatively on the doctor's workstation **410**. Many users may simultaneously connect to the server **415**. The server software can provide for highly secure communication between any user and the server itself. For example, the software can have a digital certificate that encrypts data using Secure Sockets Layer (SSL) technology. The SSL security protocol provides data encryption, server authentication, message integrity, and optional client authentication for a TCP/IP connection. SSL technology is available in 128-bit encryption key strength.

[0057] Any of the four aforementioned HRV tests may be conducted using standard HRV testing equipment and methods known in the art (e.g., using the Task Force Report for Heart Rate Variability: Standards of Measurement, Physiologic Interpretation, and Clinical Use, Circulation Vol. 93. No 5, 1996, which is incorporated herein by reference).

[0058] 4. Detecting R-Waves

[0059] The above equipment should be able to record ECG signals because, as previously noted, HRV studies concern changes in heart rate over time. Examining the change in R-R cycle length monitors these changes. The R-R cycle length is determined by measuring the amount of time in between the R waves of two consecutive QRS complexes. **FIGS. 13A-13B** illustrate one embodiment of a method, which may be implemented by the above equipment, for identifying the R-wave of an ECG signal. After beginning the process in step **1300**, step **1305** commences whereby an ECG signal is received and sampled. $X[i]$ represents an exemplar sample data point. The sampling rate may be, for example, 256 samples/second, although other sampling rates may suffice. In step **1310**, sample $X[i]$ is processed by a band pass filter (BPF). The band pass filter may have, for example, a pass band of 5-40 Hz, thereby removing DC, baseline drift, high frequency noise, artifact and muscle activity, which normally occupies, approximately, the 100 Hz frequency range. The band pass filter may be elliptical in nature to promote better signal quality and diminish distortion.

[0060] In step **1315**, the previously filtered data is filtered once more in a moving average filter (MAF). In one embodiment of the invention, the MAF is a sixth order filter, although other orders may suffice. The MAF output is represented by the following equation:

$$Y[i-n/2]=1/n*(X1 [i-n]+X1 [i-n+1]+ \dots +X1 [i]).$$

[0061] Using a MAF helps ameliorate the effects of noise by examining multiple samples at once. Doing so helps diminish the effect of outlier points that may be present due to noise. In one embodiment of the invention, the MAF may average seven samples at a time, but fewer or more samples may be filtered. This moving window smoothes out the effects of noise yet avoids becoming a burden on processing bandwidth. Thus, the calculations may be done in real time. The MAF plays an important role because noise is a constant problem in many HRV testing situations, especially since clinical settings may have other noise-emitting equipment in the room. In addition, the HRV equipment is often used by individuals not accustomed to proper skin preparation and electrode placement which are important for high quality ECG recordings. While the MAF is described in one embodiment of the invention, various filtering and signal averaging techniques may be used in various embodiments of the invention. Those of ordinary skill in the art will realize the aforementioned filtering techniques may be carried out in hardware or software.

[0062] In step **1320** of **FIG. 13A**, the amplitude difference in consecutive samples is calculated to obtain slope. Such a calculation is represented by the following equation: $D[i]=Y[i-n/2]-Y[i-n/2-1]$, wherein $D[i]$ represents slope. To magnify the slope, $D[i]$ may be squared or raised to an exponential power, such as 4, although other powers may suffice. Choosing an even power converts negative amplitude readings into positive values, thereby accounting for negative R waves or positive R waves that read as negative R waves due to improper electrode placement. Again, electrode placement may be improper due to administration of HRV tests by individuals that lack specialized, cardiac-related experience. For example, this may occur if a patient at home uses the present invention.

[0063] In step **1325**, $D[i]$ slope is compared to the preceding ($D[i-1]$) and succeeding ($D[i+1]$) slopes. If $D[i]$ is not greater than the other slopes, the process returns to start **1300** and $D[i]$ is not deemed to be an R wave. If $D[i]$ is greater than the other slopes, the process continues with $D[i]$ serving as a prospective R wave.

[0064] A peak slope is sought because R waves typically possess a frequency of approximately 20 Hz, a frequency higher than other waves found in the ECG. Therefore, finding the peak slope in an ECG complex leads to locating the R wave. The prior art typically searches for peak amplitude, instead of peak slope, in an effort to identify an R wave. Doing so leads to high amplitude artifacts and noise being incorrectly labeled as an R wave. Because an embodiment of the present invention focuses on slope in pursuit of the 20 Hz R wave, noise with high amplitude and high frequency can be filtered out as discussed above. A maximum amplitude, which may be indicative of noise, may not be so filtered. Also, setting a maximum amplitude threshold might accidentally remove valuable R waves with high amplitudes. In addition, HRV studies are often of major benefit to older patients in predicting various maladies, and such patients often have low amplitude R waves brought on by diminished cardiac strength. The frequency of their R waves changes, however, less drastically and is therefore preferable to amplitude. In summary, the present invention's focus on maximum frequency or slope is preferable to maximum amplitude.

[0065] The peak slope, representative of what might prove to be a R wave, may next be validated to ensure it truly represents the maximum slope of a R wave. To do so requires a pool of R waves that can be compared to the prospective R wave. In step 1330, after the prospective R wave associated with $D[i]$ has been determined, the number of previously determined R waves is questioned. In step 1335, if less than a predetermined number of such R waves have been found, step 1340 is engaged. An example of such a predetermined number of R waves is ten, although other values may be used to provide a proper pool of waves. In step 1340, $D[i]$ is compared against a threshold slope value. The minimum threshold (minTHR) may be indicative of a minimum slope commonly attributed by those of ordinary skill in the art to R waves. If $D[i]$ is less than the threshold slope, $D[i]$ is determined to not be representative of a R wave and the entire ECG detection sequence begins anew at START 1300. If $D[i]$ does exceed the threshold, further validation of the prospective R wave continues. In addition, the slope threshold is set to $D[i]$, in step 1345, for future comparisons. At the beginning of the ECG detection sequence, the threshold may be set to zero.

[0066] In step 1355, an R-R interval is calculated using the prospective R wave, which is associated with a time at which $D[i]$ occurs, and the immediately preceding, previously confirmed R wave. If no previous R wave exists, the newly confirmed R wave is stored and the ECG detection process begins anew.

[0067] In step 1360, a confirmation period begins by verifying that the R-R interval, calculated in step 1355, which is associated with $D[i]$, is greater than a minimum cycle length (minCP) and shorter than a maximum cycle length (maxCP). At the beginning of the ECG detection sequence, minCP may be set to 333 ms and maxCP may be set to 2000 ms. A typical R-R cycle length fits within these bounds. Those cycle lengths that are not within these bounds are more commonly associated with noise or other non-sinus cardiac rhythms. For example, signal artifacts, which are normally filtered out from genuine ECG data using previously described methodologies, often contain many high frequency signals, with short cycle lengths, in rapid succession. The lower bound (min CP) would help ensure these values are not labeled as R waves. The minCP and maxCP values identified above are examples only, and those of ordinary skill in the art may use other values. If the cycle length meets the requirements of step 1360, the prospective R wave is confirmed as an R wave and is no longer considered to be a prospective R wave. The R-R interval may now be used in the evaluation of many HRV parameters as previously described.

[0068] In step 1365, the number of previously determined R waves is questioned again in light of the newly determined R wave. In step 1365, if less than a predetermined number of such R waves have been found, step 1375 is engaged. An example of such a predetermined number of R waves is 10, although other values may be used to provide a proper pool of waves. In step 1375, if no such number of waves exists, the minimum threshold is set to, for example, zero. This value is set in step 1345. The ECG detection sequence then begins again in step 1300.

[0069] If there is such a predetermined amount of R waves, as illustrated in step 1380, a median value of a certain

number of immediately preceding, previously detected peak slopes, each associated with a previously determined R wave, may be calculated. The selected peak slopes do not have to immediately precede the most recently confirmed R wave. There may be maximum number of preceding R waves that may be entered into the median calculation. The maximum number is thirty in one embodiment of the invention. The median peak slope value is calculated and then multiplied by a first predetermined value to obtain a new minimum threshold (minTHR). The median may also be multiplied by a second predetermined value to obtain a new maximum threshold (maxTHR). In one embodiment of the invention, the first predetermined value is 0.0625 and the second predetermined value is 1.6. Both values were arrived at empirically and are only exemplar values. Other values may be used. In addition, mean, average or mode values, or similar methods related thereto, may be substituted for median values.

[0070] In step 1385, the minCP and maxCP are reevaluated in light of the newly confirmed R wave. These values may be obtained by finding the minimum R-R cycle length (minRR) and maximum R-R cycle length (maxRR) from a certain number of immediately preceding, previously detected peak slopes, each associated with a previously determined R wave. The selected peak slopes do not have to immediately precede the most recently confirmed R wave. There may be maximum number of preceding R waves that may be analyzed. The maximum number is thirty in one embodiment of the invention. Once minRR and maxRR have been found, maxCP and minCP are calculated as follows:

$$\text{maxCP} = \text{maxRR} + \text{maxRR} / 2$$

$$\text{minCP} = \text{minRR} - \text{minRR} / 2$$

[0071] These formulae simply set CP thresholds equal to maximum and minimum R-R intervals, found within a set of R waves, with 50% tolerance. The level of tolerance is an empirical value and may be adjusted in other embodiments of the invention. If $\text{maxCP} > 2000$, the newly calculated maxCP is reset to 2000. If $\text{minCP} < 333$, the newly calculated minCP is reset to 333. These values, as previously described, are known to those of ordinary skill in the art as reasonable bounds for R-R intervals. In step 1390, the ECG detection process ends or loops back to step 1300.

[0072] In subsequent iterations of the ECG detection scheme, the predetermined number of previously determined R waves, as set out in step 1330, will eventually be met. Then, step 1350 may be performed. A newly determined slope may then be compared to the new minimum and maximum thresholds determined in step 1380. These values help to verify if a prospective R wave bears a resemblance to the median value of previously determined R waves. If the prospective R wave is random noise or an artifact, it would likely not pass this test. In addition, waves with smaller slopes, such as the P wave, would not exceed the minimum threshold. Because the median values may be calculated on the thirty most recently determined R waves, for example, the threshold values are adaptive to true changes in heart rate which may have been brought on by any number of factors, including provocative measures undertaken in HRV testing. After step 1350, confirmation of the prospective R wave continues as previously described and as indicated in FIG. 13A. One of ordinary skill in the art will appreciate that there

are a number of alternative embodiments available which allow for R wave detection and that such embodiments are within the scope of the present invention.

[0073] The ECG detection sequence, in its many embodiments, has several advantages over the prior art. The sequence helps combat noise and thereby identifies R waves more accurately. The method also provides flexibility in contrast to the rigid systems represented by the prior art. Such flexibility exists in, for example, the method's ability to adjust boundaries (e.g., minTHR) according to patient data that is received by the system. In addition, the resultant ability to accurately measure R-R cycle lengths, in real time, helps a clinician terminate a lengthy study, such as the 5 Minute Resting HRV study, if poor signals are being generated. Then, for example, electrode patches can be re-applied and the test can begin again.

[0074] 5. Further Verifying R Waves

[0075] FIG. 15A illustrates an embodiment of a method for further verifying that the above process has accurately detected R waves. The method helps distinguish abnormal waves from normal R waves. The abnormal waves may be, for example, artifact signals produced by sources other than the heart. Such artifact may be due to a clinician contacting a loose electrode. Other examples of abnormal waves are ectopic heart beats that produce R waves. These R waves represent heart activity other than normal waves originating from sinus node activity.

[0076] An embodiment of the verification method begins at 1500. In 1505, a sample array of "N" RR intervals is collected. DC bias is removed from the intervals in 1510. The mean ("M") and standard deviation ("σ") of the intervals is calculated in 1515. In 1520, the interval ("i") to be examined is set to "0". Using statistical methods known to those of ordinary skill in the art, in 1525 a "T" value is calculated as follows: $T = \text{absolute value of } (RR[i] - M) / \sigma$. In addition, a "t" value is ascertained using the degree of freedom table illustrated in FIG. 15B. For example, for an array of 15 RR intervals, the "N-1" degree of freedom value is 14 and the corresponding t value is 2.24. In 1530, T is compared to t. If T is not larger than t, RR[i] is likely not an abnormal beat. Consequently, in 1545 the next interval, RR[i+1], is set to be examined. If 1550 indicates RR[i] was not the last interval in the array, the process begins anew as 1555 returns to 1525 to begin analysis of RR[i+1]. If RR[i] is the last interval in the array, 1555 returns the process to 1500 to begin analysis of a new array of RR intervals.

[0077] In 1530, if T is larger than t, RR[i] may be an abnormal beat and must be analyzed further. In 1535, if RR[i] is less than 70% of RR[i-1] or more than 130% of RR[i-1], RR[i] is deemed an abnormal beat which may be indicative of artifact or, for example, an ectopic beat. In 1540, RR[i] may be set to a point that is interpolated between preceding and proceeding valid RR intervals. The interpolated point may be defined as follows: $RR[i] = (RR[i-1] + RR[i+1]) / 2$. Consequently, the abnormal wave, in its original form, is removed from further analysis. More specifically, time domain analysis of the array will not consider those RR intervals preceding and proceeding the abnormal signal. However, in frequency domain analysis, the artifact is adjusted so that the R wave is still analyzed but only at its interpolated position and not its original position. In 1545, the next interval, RR[i+1], is set to be examined. One result

from this verification process is that abnormal waves that were previously identified as R waves are no longer so identified. The method is known to those of ordinary skill in the art and is further described in the following article: D. Sepetliev, *Statistical methods in medical scientific research* (Medicine, 1968), which is hereby incorporated within.

[0078] The clinician may still wish to further verify that the R waves were accurately detected. In one embodiment of the invention, the clinician may view a display that illustrates a 5 second window of ECG data. Within the window, each normal and abnormal R wave is identified with, for example, a marker that may be in the form of a cross-hair. FIGS. 13A-13B addresses detection of normal R waves. So that the clinician has a general idea of where the 5 second window is taken from, a graph that tracks HR throughout the ECG recording is displayed. The section of the HR graph that pertains to the selected 5 second ECG window is highlighted. If the clinician locates a normal R wave not identified by the invention, he may mark the missed wave, through use of a graphical user interface (GUI), so that the system will now recognize the missed wave as a normal R wave. If there are waves, such as artifacts, that have been incorrectly identified by the invention as an R wave, the clinician may remove the marker using the GUI. If an ectopic beat has been marked as a normal R wave, the clinician may use the GUI to toggle the identification to one representing an abnormal R wave. The clinician may repeat this process, by moving from one 5 second window to another 5-second window, until the entire ECG recording has been analyzed.

[0079] 6. Generate HRV Parameters

[0080] Again referring to FIG. 1, once the autonomic tests have been administered in step 110, the resultant ECG data is measured and HRV parameters may be obtained in step 115. The exact HRV parameters generated are a function of which autonomic tests are administered. For example, the HRV parameters measured in the Metronomic test may include one or more of the following parameters listed in FIG. 16B. The HRV parameters measured in the Orthostatic test may include one or more of the parameters listed in FIG. 16A. The Valsalva ratio is measured during the Valsalva test. Finally, for the Short-Term Resting HRV test, one of more of the HRV parameters listed in FIGS. 16C-D may be derived. While the Metronomic Breathing test, Valsalva test, Orthostatic test and Short-Term Resting HRV test may result in the twenty-two exemplar parameters just listed, other HRV parameters exist and may be used.

[0081] 7. Determine Whether Normative Database Exists

[0082] Initially, no database of test results may exist from which normative values may be derived. Consequently, in step 110, a statistically significant number or population of individuals must be tested in order to generate data that can be gathered and compiled into a database. Such a population may be tested according to any number of HRV tests including the Slow Metronomic Breathing test, Valsalva test, Orthostatic test or Short-Term Resting HRV test. Assuming, in step 120, that no such database exists initially, step 125 calls for the addition of the patient data obtained in steps 105 and 110 to be added to the database, which may reside on the server 415. Patient data should continue to be collected at least until a statistically significant data set from a population of patients is achieved. What may constitute such a

statistically significant data set will be discussed in more detail in conjunction with step 135.

[0083] 8. Perform Discriminant Analysis

[0084] As test results and patient information are entered into the database, discriminant analysis of the data may begin in step 130. The data set can be classified according to any number of variables such as, for example, type of test administered (e.g., Metronomic and/or Orthostatic), parameters monitored (e.g., E/I ratio and/or SDNN), age, gender, race, smoking history and health condition (e.g., whether a patient has pancreatic cancer or simply whether a patient is healthy or ill). Healthy individuals may be included in addition to those with conditions such as diabetes or heart disease. Subsets of these variables may indicate the severity of AN related to maladies such as diabetes. On a more general note, the patients in the data set may be given a preliminary classification that helps measure the severity of various health conditions. For example, each patient in the data set may have a health classification such as "no autonomic dysfunction", "borderline dysfunction" or "clinically evident autonomic dysfunction."

[0085] In the following example of a data set, a group of 128 patients took the 5-min resting HRV test, Slow Metronomic Breathing test and Orthostatic test. All patients were 30-35 year old white, non-smoking men. The group consisted of two subgroups: 64 "healthy" patients and 64 patients with clinically evident diabetic autonomic dysfunction. The data set, comprised of background data and HRV parameters from the population of patients, was then subjected to statistical discriminatory analysis. Statistical discriminatory analysis is used to determine one or more discriminant equations wherein each such equation discriminates between, for example, patients with abnormal autonomic function and patients with normal autonomic function. Doing so indicates whether a pattern indicative of autonomic dysfunction could be found for similarly situated individuals.

[0086] Discriminant function analysis is a statistical tool used to determine which variables discriminate between two or more naturally occurring groups. For example, the analysis can be used to investigate which patient information and autonomic test parameters discriminate between individuals with autonomic dysfunction, individuals without autonomic dysfunction and borderline individuals that lie between these classifications. Discriminant analysis can then be used to determine which variable(s) are the best predictors of autonomic dysfunction. In a stepwise discriminant function analysis, such as the one used in the present example, a model of discrimination is built step-by-step. Specifically, at each step, variables are reviewed and evaluated to determine which one will contribute most to the discrimination between groups of patients. If such a contribution is made, that variable will then be included in the later analysis and the process starts again until all variables have been examined. The statistical methods incorporated in this example are known to those of ordinary skill in the art. In addition, the particular statistical analysis employed in the invention need not be the exact analysis described herein. Those of ordinary skill in the art will readily realize that other statistical methodologies may be employed to identify patterns within the data set.

[0087] Keeping with the present example, twenty-one HRV parameters, derived from three HRV tests, were gath-

ered for all 128 patients. This data is provided in FIGS. 6A-I. These test results were processed with a standard forward stepwise linear discriminant analysis. The Statistica™ 5.0 software package was used to provide this analysis, with the following parameters set for the method: Tolerance=0.010, F to enter=1.00, F to remove=0.00 and Number of steps=21 (i.e., the number of parameters to be analyzed). F is essentially computed as the ratio of the between-groups variance in the data over the pooled (average) within-group variance. If the between-group variance is significantly larger, then there must be significant differences between means. The stepwise procedure is guided by the respective "F to enter" and "F to remove" values. The F value for a variable indicates its statistical significance in the discrimination between groups. In other words, it is a measure of the extent to which a variable makes a unique contribution to the prediction of group membership. Statistica™ software is available from StatSoft, Inc., 2300 East 14th Street, Tulsa, Okla. 74104. The above-identified values are provided as examples only and may be modified by those of ordinary skill in the art in accordance with their statistical analysis design choices.

[0088] The discriminant analysis derived (i) a discriminant equation that (ii) determined 8 of the 21 parameters were statistically significant. The data for these 8 parameters, a subset of data presented in FIGS. 6 A-I, is presented in FIGS. 14 A-C. A focus on 8 of the 21 parameters demonstrated a pattern that significantly separated patients with autonomic dysfunction from those without autonomic dysfunction. The discriminant analysis indicated the other 13 parameters were not statistically relevant in discriminating between patients afflicted with autonomic neuropathy due to diabetes and those patients with normal autonomic function. The significant parameters for the 5-min Resting HRV test were RMS-SD and TP. The significant parameters for the Slow Metronomic Breathing test were E/I Ratio, SD and NNmin SB. Finally, the significant parameters for the Orthostatic test were 30:15 Ratio, NNmin Standing and NNmax Standing. A description of these parameters was set out above.

[0089] The newly derived discriminant equation is as follows:

$$Y=(21.7134 * E/I \text{ Ratio})+(0.0936 * SD)-(0.0628 * RMS-SD)+(0.0008 * TP)+(3.7881 * 30:15 \text{ Ratio})-(0.0020 * NNmin \text{ SB})-(0.0100 * NNmin \text{ Standing})+(0.0056 * NNmax \text{ Standing})-39.6343.$$

[0090] Essentially, this equation was derived so that, when the 8 relevant factors are input into the equation, any resultant Y value that is positive will be indicative of a patient with normal autonomic function. Any resultant Y value that is negative will be indicative of a patient with autonomic neuropathy due to diabetes. Those variables with the largest coefficients are the ones that contribute most to the prediction of autonomic dysfunction. Thus, in this example, the E/I ratio contributes most to the prediction because its coefficient is larger than the other coefficients.

[0091] While one discriminant equation has been identified in this example, an embodiment of the invention concerns finding one or more such equations. For example, a second equation could be derived from the same data representative of the 21 HRV parameters recorded for the above example. The first discriminant equation discriminated between patients of a population that had a first

autonomic state, such as diabetes and autonomic neuropathy, and other patients in the same population that had a second autonomic state, such as no autonomic neuropathy. A second discriminant equation might distinguish between patients with a first autonomic state, such as hypertension and autonomic neuropathy, and other patients with a second autonomic state, such as normal autonomic function and no hypertension.

[0092] Those additional equations may continue to be derived as the normative databases receive more background information and test results. Using the new data, the invention could determine an equation for discriminating between those with both coronary artery disease (CAD) and diabetes and those that have neither condition. In addition, the invention could determine another equation for discriminating between those individuals with CAD, and associated autonomic dysfunction, and those without autonomic dysfunction. Also, the invention could determine an equation for discriminating between individuals with CAD, who would have a first state of autonomic function indicative of CAD, and those with diabetes, who would have second state of autonomic function indicative of diabetes. The multiple equations, possibly derived from multiple HRV parameters taken from multiple HRV tests, provide for more accurate autonomic assessment of patients than was ever possible with prior art methods that failed to consider such discriminant equations. In short, the multiple equations allow for like individuals, such as white, 30-year old males, to have their HRV test results compared against other white, 30-year old males. Multiple equations may allow that same white, 30-year old male to have his results, using one equation, compared against 30-year old, white males with hypertension and, using a second equation, against 30-year old, white males with diabetes. In doing so, the patient's autonomic function is assessed in a more accurate and precise manner than would be the case with prior art methodologies.

[0093] Returning to the example with 128 patients, after a discriminant equation was derived, the 128 patients' test data were entered into the equation to calculate the outcome, or root, of the discriminant function. The outcome values are presented in FIG. 7A-7D. These outcomes may be identified as an autonomic ranking or autonomic dysfunction rank (ADR).

[0094] In one embodiment of the invention, when the ADR is greater than 0, the patient is considered healthy. When ADR is equal to, for example, 0, the patient is still healthy but could be considered "borderline" for autonomic dysfunction. As an ADR grows negative, a more severe autonomic dysfunction is indicated. Autonomic pathophysiology indicates there is a gradual transition, through a "borderline" phase, from a healthy condition to a pathological one. Taking this approach, a "borderline zone" may be defined, for example, as plus/minus 5% of the variance of the discriminant function derived from the entire set of 128 patients. Therefore, if $ADR_{min} = -12.1825$ and $ADR_{max} = 11.3844$, then $R = 23.5669$ and the borderline zone will range from -1.1784 to $+1.1784$.

[0095] 9. Store Discriminant Equation

[0096] The newly derived equation should be added to a database, step 135, along with any previously derived and still valid equations, for use with future patients. In one embodiment of the invention, the process is continued until

a statistically significant number of patients have been examined and one or more discriminant equations have been derived. As an example of achieving a statistically significant data set, analyzing patterns among patient gender, fourteen different categories of age, five categories of race, and two categories of health (e.g., those with and without clinically evident autonomic dysfunction) may require 12,500 patients assuming each unique combination of variables should have about 44 data points recorded.

[0097] 12,500 patients were pursued in the present example for at least the following reasons. In discriminant analysis, the number of observations for a group that will be studied should be higher than the total number of parameters that will be tested for that group. Therefore, using all four previously described HRV tests will produce 22 HRV parameters. Consequently, more than 22 observations should be made for each group that will be studied. To be conservative, 44 data points were gathered, which doubles the required minimum number of observations (22). Regarding the number of groups to be studied, two patient genders, fourteen different categories of age, five categories of race, and two categories of health result in 280 different groups or types of patients that were to be studied. 280 groups multiplied by 44 data points per group equates to 12,500 tests that should be considered. While a specific example of what constitutes a statistically relevant population has been addressed herein, a determination of when a statistically valid amount of data has been collected is well known to those of ordinary skill in the art and may vary from that described above.

[0098] 10. Choose Applicable Discriminant Equation for New Patient

[0099] Moving back to step 120 in FIG. 1, once a normative data set has been created from a statistically significant population of patients, new patients may be evaluated in relation to the norms found within the population data set. In one embodiment of the invention, the new patient is subjected to the Metronomic Breathing test, Valsalva test, Orthostatic test and Short-Term Resting HRV to produce ECG data in step 110, after first having background data taken in step 105. The ECG data is then measured to obtain HRV parameters in step 115. One may choose to use multiple tests because an autonomic abnormality may manifest itself in, for example, the Valsalva test but not the Orthostatic test. Patients with specific severe cardiac conditions, however, may only be capable of Short-Term Resting HRV testing due to the patient's elevated risk for abnormal cardiac events.

[0100] In step 145, a new patient that is, for example, a 35 year old, white, non-smoking man with clinically evident signs of autonomic dysfunction caused by diabetes (Patient 1) is evaluated against the discriminant equation derived earlier. In addition, a 31 year old, white, non-smoking man who is apparently healthy (Patient 2) is also evaluated against the above discriminant equation. However, the above discriminant equation may not be selected for a 30 year old, Hispanic, smoking woman with clinically evident signs of autonomic dysfunction caused by CAD because the above equation is based on data from 30-35 year old white, non-smoking men. Still, an investigator may choose to evaluate the exemplar Hispanic woman against all known discriminant equations, including the one that is the subject

of the present example, associated with individuals aged 30 to 35 years. In contrast, the investigator may choose to compare the exemplar Hispanic woman only with other smoking, 30-year old Hispanic women. Therefore, in one embodiment of the invention, one or more discriminant equations are selected in response to the background data from the new patient. This selection may be performed automatically by the invention or manually by the clinician.

[0101] 11. Generate Autonomic Ranking

[0102] Using Patients 1 and 2 as examples, the patients may be subjected to, for example, the 5-min resting HRV test, Slow Metronomic breathing test and Orthostatic test, producing HRV data as shown in **FIG. 8**. These results should contain all eight parameters values called for by the previously derived exemplar discriminant equation. In step **150**, the eight HRV parameters are input into the selected discriminant equation to produce autonomic rankings, as seen in step **155**, that are indicative of the patient's autonomic function, as follows:

[0103] Patient 1:

$$(21.7134*1.1075)+(0.0936*31.48)-(0.0628*27.51)+ \\ (0.0008*63.64)+(3.7881*1.083)-(0.0020*572)-(0.010*372)+ \\ (0.0056*592)-39.6343=-11.828 \text{ (ADR)}$$

[0104] Patient 2:

$$(21.7134*1.3966)+(0.0936*110.76)-(0.0628*52.63)+ \\ (0.0008*1020.37)+(3.7881*1.349) \\ (-0.0020*748)-(0.0100*620)+(0.0056*936)-39.6343=1.1659 \\ \text{(ADR)}$$

[0105] 12. Present Autonomic Rankings to Clinician

[0106] Although the discriminant function produces a positive autonomic ranking of 1.1659 for Patient 2, the value falls into the borderline zone, instead of normal or abnormal zones, as illustrated in step **160** and by Point **910** in **FIG. 9**. Even though there is no clinical manifestation of autonomic dysfunction, the patient will be considered "borderline." Thus, while Patient 2 showed no clinically evident signs of autonomic dysfunction, he is clearly at risk for developing such dysfunction. The autonomic ranking may be classified as being indicative of a propensity for Patient 2 to develop a specific illness such as diabetes. Considering many individuals have autonomic dysfunction that does not manifest itself clinically, the results for Patient 2 are critical. Patient 2 can now work with his clinician to manage his lifestyle towards autonomic improvement. Furthermore, the effects of any prescribed regimen can be evaluated when subsequent test results are compared to the first autonomic ranking. Concerning the exact display illustrated in **FIG. 9**, one of ordinary skill in the art will appreciate that the autonomic ranking may be presented to the clinician or patient in many different ways and that the various display embodiments are within the scope of the present invention. For example, an exemplar display may be three dimensional with clouds or sectors that identify different scores that are indicative of different maladies. The patient's ADR could then be plotted in view of these clouds or sectors. The patient may then readily realize his proximity to different maladies. The clinician may then order specific tests for maladies that the patient is at risk for contracting. The clinician may also make referrals to, for example, an oncologist for a patient who is borderline for pancreatic cancer. In one embodiment of the invention, the referral to other doctors or necessity for other tests may be performed automatically by the invention.

[0107] Returning the above example, in contrast to Patient 2, Patient 1 has a very negative autonomic ranking of 11.828. This ranking confirms the clinical assessment of autonomic dysfunction. Now that Patient 1 has an objective ranking to corroborate his clinical assessment, he may more easily monitor the effectiveness of therapy or a change a lifestyle upon his autonomic function by comparing his future autonomic rankings with the present ranking. Along these same lines, pharmaceutical companies may easily track the efficacy of certain drugs by using these HRV results.

[0108] 13. Amend Normative Database

[0109] After step **155** and, for example, step **160**, some or all of Patient 2's background information, HRV data and ECG data may be added to the normative database where discriminant analysis may again be performed. This step allows for the database to consider additional data that is of critical import for HRV analysis, especially considering: the possible lack of normative values addressing, for example, the relationship between HRV and CAD or the relationship between race, smoking status, pancreatic cancer and HRV.

[0110] In one embodiment of the invention, a patient's autonomic ranking for condition 1, obtained in year 1, may later be compared with the patient's autonomic ranking for condition 1, obtained in year 2. The normative values may be archived on the test evaluation server **415** as the normative database grows to ensure a patient's autonomic test results in year 2 can be compared against normative values from year 1. Similarly, a patient's test results from year 1 can be archived so they can later be compared with normative values from year 2, thereby allowing a health care provider to more fully take advantage of updated normative values as they develop. In this way, the invention could periodically test prior test results against updated normative values to determine if a patient's autonomic ranking should be revised in light of improved normative values and/or newly derived discriminant equations.

[0111] Thus, an alternative embodiment of the invention entails ongoing health care for the patient. As HRV testing becomes more popular with clinicians, normative databases will be more populated with data. As these normative databases grow, new discriminant equations will be derived or determined and previously determined discriminant equations may be modified.

[0112] Returning to the above example concerning Patient 1, a clinician may continue to monitor Patient 1 over time. For example, the clinician may input Patient 1's HRV test parameters from Patient 1's initial HRV test into a newly determined discriminant function, derived from background data and physiologic data from a second population of patients, to produce an alternative, or new, autonomic ranking. The alternative ranking may indicate that Patient 1's initial HRV parameters, which produced a "borderline" ranking, may now indicate an "abnormal" ranking based on updated normative values. The invention could then alert the clinician to contact Patient 1 to reassess any prescribed therapy or to conduct further testing, such as a test for diabetes in Patient 1's case. In one embodiment of the invention, the patient's various autonomic rankings are displayed in proximity to one another so the patient can readily appreciate how his autonomic function has changed over time.

[0113] In yet another alternative embodiment, the clinician may collect new physiologic data, such as ECG readings and the resultant HRV parameters, from Patient 1. The clinician may then input the additional physiologic data from Patient 1 into the initially derived discriminant function to produce a second autonomic ranking, wherein the second autonomic ranking is indicative of Patient 1's alternative autonomic function. The two autonomic rankings could then be compared with one another to determine how Patient 1's autonomic function is progressing. The embodiment of the invention could indicate to the clinician that there has been a change between the two autonomic rankings that exceeds a predetermined amount. If the change was for the worse, the clinician could then order needed tests, such as a test for diabetes in Patient 1's case. As an additional embodiment, Patient 1's new physiologic data could be input into newly derived discriminant equations to provide up to date autonomic function results. The two autonomic rankings could be displayed in proximity to one another thus facilitating comparisons between the two rankings.

[0114] As a normative database grows, the discriminant equations will become more discriminating and be able to connect autonomic rankings to indicators of whether a patient suffers from, or is at a heightened risk for contracting, a specified illness, such as, for example, diabetes, coronary artery disease, anxiety, depression, sudden cardiac death, myocardial infarction and hypertension. Other HRV-related maladies are described further in the Task Force Report for Heart Rate Variability: Standards of Measurement, Physiologic Interpretation, and Clinical Use, Circulation Vol. 93, No 5, 1996, which is incorporated herein by reference. Those of ordinary skill in the art will readily appreciate that the methods and apparatuses described herein may be used to identify other maladies not specifically mentioned or described and that identification of such maladies is included within the scope of the invention.

[0115] The end result of steps 100 through 160 is that a patient with certain characteristics can be compared with like individuals in a very specific and accurate fashion. Thus, the normative database, discriminatory equations, autonomic test parameters and background patient data will allow a forty year old, white man with pancreatic cancer and a history of heavy smoking to have his autonomic data compared with like individuals to determine his predisposition for maladies found within those like individuals.

[0116] One of ordinary skill in the art will appreciate that there are a number of other alternative embodiments available which allow for the identification of autonomic dysfunction patterns and for the application of the identified patterns to new patient data, and that such embodiments are within the scope of the present invention. In addition, the various embodiments of the invention are not directed solely towards traditional HRV testing. For example, certain embodiments of the invention may be used for HRV and spirometric testing of non-human animals, such as horses, cattle, dogs and cats, are within the scope of the invention. The invention may be used in other non-traditional settings. For example, embodiments of the invention may be used for battlefield or civilian assessment of biological warfare efforts. HRV testing may evaluate whether an individual has been exposed to a toxin or a chemical or biological agent. The effects of such agents may have immediate or delayed expression in the afflicted individual. This expression may

manifest itself by a decrease in autonomic function. The various embodiments of the invention may be used to detect such a decrease in autonomic function. Embodiments of the invention may then monitor improvements in the autonomic function as well. In short, one of ordinary skill in the art will appreciate that application of the invention is not limited to traditional HRV testing and that non-traditional uses of the invention are encompassed within the scope of the invention.

[0117] 14. Application Service Provider Model and Other Alternative Embodiments

[0118] An alternative embodiment of the invention concerns an Application Service Provider ("ASP") model. Generally, in an ASP model, a business offers software application capabilities, from centralized data centers via wide area networks, including the Internet, to remote users. For users, an ASP is a kind of outsourcer wherein users are not required to buy and own software applications accessed from the ASP. For example, Microsoft may provide to users access to the most current versions of applications such as Microsoft Word and Microsoft Excel over the Internet from a web server running such applications. Microsoft may then charge the users on a per use basis. Generally, in the long run such programs will be more up to date than the off the shelf versions available for purchase by users. Another advantage of the ASP model is that users can run available applications with a thin client, also known as NetPCs or NetStations. The ASP will provide such thin clients with access to applications such as word processing and spreadsheet applications, will store a user's personal files, and provide all necessary processing power for running such applications.

[0119] Referring to FIG. 10, there is illustrated a block diagram of an ASP system configured in accordance with an embodiment of the present invention. A user at their client machine with a browser 1002 loaded thereon has access to the Internet 1003. Please note that the present invention should not be limited to the Internet, but is also applicable to any local area network, wide area network, or global communications network. The user will type in a URL into their browser 1002 to access the web server 1001 of the ASP they desire to contact. Once the user has accessed the ASP, the user will then be able to select an application 1004 being run on the ASP's web server 1001. Such an application 1004 could be a spreadsheet program, such as Microsoft Excel or an application for measuring autonomic function. In such a process, instead of the user having to purchase the software for the application and load it onto their client machine, the user may use their browser 1002 to access all of the features of the application 1004 over the Internet 1003 through the web server 1001 of the ASP. Typically, GUIs (graphical user interface) of the application will be sent to the user for viewing on their browser 1002, and the user will insert data, for example a letter or memo they wish to create in a word processing application, which data will be uploaded from the browser 1002 to the application 1004 running on the web server 1001 of the ASP. The process for performing this function is well known in the art.

[0120] For example, in FIG. 11, once a clinician (MD) has a candidate (patient) (step 1100) for HRV testing, in step 1105, he may use a browser 1002, located on his workstation 410 or testing unit 405, to access the web server 1001 (i.e., test evaluation server 415) and application 1004. In step

1110, if the clinician has an account with the ASP, he may log in to the application **1004**. In step **1120**, if no such account exists, he may contact the ASP to open an account. Once the application **1004** confirms the clinician has a viable account in step **1115**, the application **1004** may display a list of available tests in step **1125**. These tests may be packaged in any number of ways. The display may, using a pull down menu, as an example, offer the clinician the option of selecting one Valsalva test and one Metronomic test. The display may offer, however, tests in packages, where purchasing one test package amounts to purchasing one Metronomic test, one Valsalva test, one resting HRV test and one Orthostatic test.

[**0121**] Each test may have a unique identifier assigned to it. This unique identifier may be used for billing purposes by the application **1004**. For example, the unique identifier may be associated with receivables such as spirometric mouthpieces. When the clinician purchases a Metronomic test, the ASP may also bill the clinician for the mouthpiece that is required for use with the test. The mouthpieces may have been shipped, in bulk, to the clinician at an earlier time. This may further aid in other billing concepts. For example, a clinician could be billed for 10 spirometric mouthpieces after 10 HRV tests have been purchased. A unique identifier may also be assigned to the patient. This will facilitate tracking the patient's medical records because the identifier would be stored or coupled to the server **1001**. For example, while a patient may discontinue seeing a particular clinician, the patient would not have to transfer his files to the office of another clinician. The second clinician could access the patient's medical files using the patient's unique identifier, a browser **1002**, the internet **1003**, the application **1004** and the server **1001**. The unique identifier of the patient may be linked to the unique identifier associated with the test. The patient information could be protected in any number of ways, including using the Secure Sockets Layer (SSL) technology SSL described earlier.

[**0122**] In step **1130** of FIG. 11, the clinician chooses a test. The application **1004**, in step **1135**, then may prompt, using a dialog box for example, the user to enter background data from a patient as well as physiologic data from a patient into the application. This step may be implemented in an automatic fashion whereby, upon docking the testing unit **405** to the doctor's workstation **410**, the background and physiologic data may be automatically uploaded to the doctor's workstation **410**. The application **1004** may then interrogate the doctor's workstation **405** after the clinician replies affirmatively to the application's prompt in step **1135**. Of course the doctor's workstation **410** may be omitted and the testing unit **405** may interact directly with the application **1004**.

[**0123**] After the background and physiologic data has been uploaded to the application **1004**, the application may choose, in step **1140**, one or more discriminant equations that are applicable to the transferred data. For example, the application **1004** may have previously derived two discriminatory equations from a population of data. One equation may identify a pattern that discriminates between a population of individuals with normal autonomic function and individuals with abnormal autonomic function. Another equation may discriminate between 30 year black men with hypertension and 30-year-old black men without hypertension. If the clinician sends data to the application **1004**

concerning a 30-year-old black man, the application **1004** may choose both equations for application **1004** to the new patient data. If the clinician transmits data from a 50-year-old white woman, the application may only select the equation that discriminates broadly between individuals with normal autonomic function and those without normal autonomic function.

[**0124**] In step **1145**, the application **1004** applies the new patient data to the selected equations and generates one or more ADRs or autonomic rankings. In step **1150**, the application **1004** may incorporate the autonomic ranking into a report that may be saved on the server **1001**, in step **1155**, and/or be sent over the internet **1003** to the doctor's workstation **410** or testing unit **405** in step **1160**. Then, considering the test is complete and a report has been sent to the clinician, in step **1165**, the application **1004** may decrease the number of available credits for studies the clinician has purchased by one. The application may then prompt the clinician to order additional tests if less than a predetermined number of tests are then available to the clinician. The process may then end in step **1170**.

[**0125**] The physiologic data that may be sent in step **1135** may be, for example, raw ECG data or processed ECG data. Thus, the ECG data from a patient's HRV study may be sent in the form it was collected as to the application **1004**. The ECG data may be, however, sent to the application **1004** only after artifact and abnormal heartbeats have been removed using the processes described above. Yet again, the ECG data may be analyzed locally thus deriving values or HRV parameters such as SDNN or RMS-SD. These HRV parameters may be sent alone to the application **1004** or may be derived by the application **1004** from ECG data previously sent to the application **1004**. In order to create more comprehensive and increasingly accurate normative databases, newly acquired raw ECG data and/or processed ECG data and/or physiologic parameters or values may all be sent to the server **1001** for further analysis at, for example, a later time.

[**0126**] The application **1004** is not limited to the HRV sector. For example, the application **1004** may be used with other medical testing, such as in general spirometry testing. A clinician may choose a test from the application **1004**. Upon transferring physiological data to the application **1004**, the application **1004** may analyze the data and return results to the clinician or provide other services that allow the clinician to analyze the data. Upon purchasing a test from the application **1004**, the application **1004** may bill the clinician for a spirometric mouthtube if such a device is needed to perform the test. Various blood tests could be used with the model as well. Upon purchasing a test from the application **1004**, the clinician could be billed for a testing kit that might include a syringe, blood tube, bandages and other related equipment.

[**0127**] In addition, ECG analysis services are within the scope of the invention. Rather than providing expensive ECG analysis technologies within a clinician's office, physiological data (e.g., ECG data) could be transmitted to the application **1004** whereby the ECG data is analyzed and test results are returned to the clinician. The process could be repeated for that patient at later dates. Then, the application **1004** could display the various ECG tests to the clinician, using a browser **1002**, to quickly illustrate differences in the

patient's ECG recordings over time. This aspect of the invention would be of paramount importance by an emergency room clinician that must quickly access a patient's medical records without waiting for files to be forwarded to the emergency room. The clinician could use the internet to access ECG files located on the server **1001**. Using a unique identifier associated with each ECG test, the application **1004** could bill the clinician for, as an example, ECG patches and the like.

[**0128**] While various examples have been described above for using the ASP model, one of ordinary skill in the art will realize that any number of medical services may be provided with the ASP model and that those services are encompassed within the scope of the present invention.

[**0129**] Referring to **FIG. 12**, an example is shown of a data processing system **1200**, which may be used for implementing any of the aforementioned embodiments of the invention, including one or more of the client machines **1002** and the web server **1001**. The system has a central processing unit (CPU) **1210**, which is coupled to various other components by system bus **1212**. Read only memory ("ROM") **1216** is coupled to the system bus **1212** and includes a basic input/output system ("BIOS") that controls certain basic functions of the data processing system **1200**. Random access memory ("RAM") **1214**, I/O adapter **1218**, and communications adapter **1234** are also coupled to the system bus **1212**. I/O adapter **1218** may be a small computer system interface ("SCSI") adapter that communicates with a disk storage device **1220**. Communications adapter **1234** interconnects bus **1212** with an outside network enabling the data processing system to communicate with other such systems. Input/Output devices are also connected to system bus **1212** via user interface adapter **1222** and display adapter **1236**. Keyboard **1224** and mouse **1226** are interconnected to bus **1212** via user interface adapter **1222**. Display adapter **1236** connects display monitor **1238** to system bus **1212**. In this manner, a user is capable of inputting to the system throughout the keyboard **1224** or mouse **1226** and receiving output from the system via display **1238**.

[**0130**] Embodiments of the invention may be implemented as a computer system programmed to execute the method or methods described herein, and as a computer program product. According to the computer system implementation, sets of instructions for executing the method or methods are resident in the random access memory **1214** of one or more computer systems configured generally as described above. Those of ordinary skill in the art will appreciate that the computer program product or software program instructions are capable of being distributed as one or more program products, in a variety of forms. Processor **1210**, from either a client machine **1002** and/or server computer **1001**, may execute one or more of the computer program products stored in memory **1214**. Client computer **1002** and server computer **1001** may be individually programmed to collectively execute the process or processes of the invention described herein. Until required by the computer system, the set of instructions may be stored as a computer program product in another computer memory, for example, in disk drive **1220** (which may include a removable memory such as an optical disk or floppy disk for eventual use in the disk drive **1220**). Further, the computer program product can also be stored at another computer and transmitted when desired to the user's workstation by a

network or by an external network such as the Internet. One of ordinary skill in the art would appreciate that the physical storage of the sets of instructions physically changes the medium upon which it is stored so that the medium carries computer readable information. The change may be electrical, magnetic, chemical, biological, or some other physical change. While it is convenient to describe the invention in terms of instructions, symbols, characters, or the like, the reader should remember that all of these and similar terms should be associated with the appropriate physical elements.

[**0131**] As yet another embodiment of the invention, an embodiment of the invention entails a, networked data processing environment. The data processing environment is an arrangement, as previously described, of one or more client computers **1002** and server computers **1001** (generally "hosts") connected to each other by a network **1003**, for example, the Internet. Users access information and interface with network **1003** and server computer **1001** through a client computer **1002**.

[**0132**] Note that the invention may describe terms such as comparing, validating, selecting, identifying, or other terms that could be associated with a human operator. However, for at least a number of the operations described herein, which form part of at least one of the embodiments, no action by a human operator is required. The operations described are, in large part, machine operations processing electrical signals to generate other electrical signals.

[**0133**] Additionally, the foregoing detailed description has set forth various embodiments of the present invention via the use of block diagrams, flowcharts, and/or examples. It will be understood by those of ordinary skill in the art that each block diagram component, flowchart step, and operations and/or components illustrated by the use of examples can be implemented, individually and/or collectively, by a wide range of hardware, software, firmware, or any combination thereof. The present invention may be implemented as those of ordinary skill in the art will recognize, in whole or in part, in standard Integrated Circuits, Application Specific Integrated Circuits (ASICs), as a computer program running on a general-purpose machine having appropriate hardware, such as one or more computers, as firmware, or as virtually any combination thereof and that designing the circuitry and/or writing the code for the software or firmware would be well within the skill of one of ordinary skill in the art, in view of this disclosure. It will also be understood that certain of the above-described structures, functions and operations of the above-described embodiments are not necessary to practice the present invention and are included in the description simply for completeness of an example embodiment or embodiments. In addition, it will be understood that specific structures, functions and operations set forth in the above-referenced patents and publications can be practiced in conjunction with the present invention, but they are not essential to its practice. It is therefore to be understood that within the scope of the claims, the invention may be practiced otherwise than as specifically described without actually departing from the spirit and scope of the present invention. Finally, all patents, publications and standards referenced herein are hereby incorporated by reference.

What is claimed is:

1. A method for assessing autonomic function comprising the steps of:

receiving background data from a population of patients wherein the population of patients is comprised of a first group of patients with a first state of autonomic function and a second group of patients with a second state of autonomic function;

receiving physiologic data from the population of patients;

determining from the physiologic data and the background data a first discriminant equation that discriminates between the first group of patients with the first state of autonomic function and the second group of patients with the second state of autonomic function;

receiving physiologic data from a new patient; and

inputting the physiologic data from the new patient into the first discriminant equation to provide a first autonomic ranking that is indicative of an autonomic function of the new patient.

2. The method of claim 1 wherein the physiologic data from the population of patients comprises at least one HRV measurement; wherein the HRV measurement is selected from the group consisting of: 30:15 Ratio, NNmin Standing, NNmax Standing, Tmax, Trec, E/I Ratio, SD, NNmin SB, NNmax SB, VARmax, VARmean, RMS-SD, NN, SDNN, TP, LFnorm, HFnorm, LF/HF, VLF, LF, HF, VR and combinations thereof.

3. The method of claim 1 wherein the physiologic data from the new patient comprises at least one HRV measurement; wherein the HRV measurement is selected from the group consisting of: 30:15 Ratio, NNmin Standing, NNmax Standing, Tmax, Trec, E/I RATIO, SD, NNmin SB, NNmax SB, VARmax, VARmean, RMS-SD, NN, SDNN, TP, LFnorm, HFnorm, LF/HF, VLF, LF, HF, VR and combinations thereof.

4. The method of claim 1 wherein the background data from the population of patients includes age and at least one selection from the group consisting of: race, gender, smoker status and health condition.

5. The method of claim 1 further comprising the steps of:

receiving background data from an additional population of patients wherein the additional population of patients is comprised of a third group of patients with a first state of autonomic function and a fourth group of patients with a second state of autonomic function;

receiving physiologic data from the additional population of patients;

determining from the physiologic data from the additional population of patients and the background data from the additional population of patients a second discriminant equation that discriminates between the third group of patients with the first state of autonomic function from the additional population of patients and the fourth group of patients with the second state of autonomic function from the additional population of patients; and

inputting the physiologic data from the new patient into the second discriminant equation to provide a second

autonomic ranking that is indicative of an alternative autonomic function the new patient.

6. The method of claim 5 further comprising the step of indicating if the second autonomic ranking differs by a predetermined amount from the first autonomic ranking.

7. The method of claim 5 further comprising the step of displaying the first and second autonomic rankings in proximity to each other.

8. The method of claim 1 further comprising the steps of:

receiving background data from an additional population of patients wherein the additional population of patients is comprised of a third group of patients with a first state of autonomic function and a fourth group of patients with a second state of autonomic function;

receiving physiologic data from the additional population of patients;

determining from the physiologic data from the additional population of patients and the background data from the additional population of patients a second discriminant equation that discriminates between the third group of patients with the first state of autonomic function from the additional population of patients and the fourth group of patients with the second state of autonomic function from the additional population of patients;

receiving additional physiologic data from the new patient; and

entering the additional physiologic data from the new patient into the second discriminant equation to produce a second autonomic ranking, wherein the second autonomic ranking is indicative of an alternative autonomic function of the new patient.

9. The method of claim 8 further comprising the step of displaying the first and second autonomic rankings in proximity to each other.

10. The method of claim 1 further comprising the steps of:

receiving additional physiologic data from the new patient; and

inputting the additional physiologic data from the new patient into the first discriminant equation to produce a second autonomic ranking, wherein the second autonomic ranking is indicative of an alternative autonomic function of the new patient.

11. The method of claim 10 further comprising the step of indicating if the second autonomic ranking differs by a predetermined amount from the first autonomic ranking.

12. The method of claim 10 further comprising the step of displaying the first and second autonomic rankings in proximity to each other.

13. The method of claim 1 further comprising the step of classifying the first autonomic ranking as a condition.

14. The method of claim 13 wherein the condition is selected from the group consisting of: normal, abnormal, borderline and combinations thereof.

15. The method of claim 1 further comprising the step of classifying the first autonomic ranking as being indicative of an illness.

16. The method of claim 15 wherein the illness is selected from the group consisting of: diabetes, coronary artery disease, anxiety, depression, sudden cardiac death, myocardial infarction and hypertension.

17. The method of claim 1 wherein the first state of autonomic function is indicative of an illness; wherein the illness is selected from the group consisting of: diabetes, coronary artery disease, anxiety, depression, sudden cardiac death, myocardial infarction and hypertension.

18. The method of claim 1 wherein the second state of autonomic function is indicative of an illness; wherein the illness is selected from the group consisting of: diabetes, coronary artery disease, anxiety, depression, sudden cardiac death, myocardial infarction and hypertension.

19. The method of claim 1 further comprising the step of adding at least a portion of the additional physiologic data from the new patient to the physiologic data from the population of patients.

20. One or more program storage media readable by a machine and containing instructions for performing the method contained in claim 1.

21. The method of claim 1 wherein the physiologic data from the new patient is obtained pursuant to the following steps:

receiving a first set of ECG data from the patient wherein the first set of ECG data is recorded while the patient is in a substantially reclined position and is breathing in a non-provoked manner;

measuring the first set of ECG data to obtain a first HRV measurement;

receiving a second set of ECG data from the patient wherein the second set of ECG data is recorded pursuant to one or more HRV tests; wherein the one or more HRV tests is selected from the group consisting of: Orthostatic test, Metronomic test and Valsalva test; and

measuring the second set of ECG data to obtain a second HRV measurement that is related to the one or more HRV tests, wherein the physiologic data from the new patient is comprised of the first HRV measurement and the second HRV measurement.

22. The method of claim 21 wherein the first HRV measurement is selected from the group consisting of: RMS-SD, NN, SDNN, TP, LFnorm, HFnorm, LF/HF, VLF, LF, HF and combinations thereof.

23. The method of claim 1 wherein the population of patients is further comprised of non-human patients.

24. A system for assessing autonomic performance comprising:

a memory unit operable for storing one or more computer products for assessing autonomic performance; and

a processor coupled to the memory unit, wherein the processor executes the one or more computer products for performing the steps of:

receiving background data and HRV data from a population of patients having patients with a first state of autonomic function and patients with a second state of autonomic function;

performing discriminant analysis on the HRV data and the background data from the population of patients to determine a plurality of discriminant equations wherein each discriminant equation discriminates between the

patients with the first state of autonomic function and the patients with the second state of autonomic function;

receiving background data and HRV data from a new patient;

selecting a discriminant equation from the plurality of discriminant equations in response to the background data from the new patient; and

inputting the HRV data from the new patient into the selected discriminant equation to provide an autonomic ranking that is indicative of an autonomic function of the new patient.

25. The system of claim 24 wherein the background data from the new patient includes age and at least one selection from the group consisting of: race, gender, smoker status and health condition.

26. The system of claim 24 wherein the processor executes the one or more computer products for performing the step of selecting the discriminant equation from the plurality of discriminant equations in a substantially automatic manner.

27. The system of claim 24 wherein the processor executes the one or more computer products for performing the additional step of classifying the autonomic ranking as a classification selected from the group consisting of: normal, abnormal, borderline and combinations thereof.

28. The system of claim 24 wherein the processor executes the one or more computer products for performing the step of classifying the autonomic ranking as being indicative of an illness.

29. The system of claim 28 wherein the illness is selected from the group consisting of: diabetes, coronary artery disease, anxiety, depression, sudden cardiac death, myocardial infarction and hypertension.

30. The system of claim 24 wherein the processor executes the one or more computer products for performing the steps of:

receiving additional HRV data from the new patient; and

inputting the additional HRV data from the new patient into the selected discriminant equation to provide a second autonomic ranking that is indicative of an alternative autonomic function of the new patient.

31. The system of claim 30 further comprising a display that displays both the first autonomic ranking and the second autonomic ranking.

32. The system of claim 24 wherein the processor executes the one or more computer products for performing the steps of:

receiving background data and HRV data from an additional population of patients having patients with a first state of autonomic function and patients with a second state of autonomic function;

performing discriminant analysis on the HRV data and the background data from the additional population of patients to determine a second plurality of discriminant equations wherein each of the second plurality of discriminant equations discriminates between the patients with the first state of autonomic function from the additional population of patients and the patients with the second state of autonomic function from the additional population of patients;

selecting a discriminant equation from the second plurality of discriminant equations in response to the background data from the new patient; and

inputting the HRV data from the new patient into the selected discriminant equation from the second plurality of discriminant equations to provide a second autonomic ranking that is indicative of an alternative autonomic function of the new patient.

33. The system of claim 32 further comprising a display that displays both the first autonomic ranking and the second autonomic ranking.

34. The system of claim 24 wherein the population of patients is further comprised of non-human patients.

35. A method for assessing autonomic performance using a computer system, wherein the computer system includes one or more client computers, a server computer coupled to the one or more client computers, one or more memories coupled to the server computer, and one or more computer program products stored in the one or more memories, the method comprising:

storing a population data set, comprised of physiologic data and background data received from a population of patients wherein the population of patients is comprised of patients with a first state of autonomic function and patients with a second state of autonomic function, in the one or more memories;

using the one or more computer program products to process the population data set to determine a first discriminant equation that discriminates between the patients with the first state of autonomic function and the patients with the second state of autonomic function;

storing the first discriminant equation in the one or more memories;

using the one or more client computers to access the first discriminant equation; receiving physiologic data from a new patient;

and entering the physiologic data from the new patient into the first discriminant equation to produce a first autonomic ranking, wherein the first autonomic ranking is indicative of an autonomic function of the new patient.

36. The method of claim 35 wherein the step of entering the physiologic data from the new patient into the first discriminant equation may be performed in a manner; wherein the manner is selected from the group consisting of: manually and importing.

37. The method of claim 35 further comprising the step of adding the physiologic data from the new patient to the population data set.

38. The method of claim 35 further comprising:

storing an additional population data set, comprised of physiologic data and background data received from an additional population of patients wherein the additional population of patients is comprised of patients with a first state of autonomic function and patients with a second state of autonomic function, in the one or more memories;

using the one or more computer program products to process the additional population data set to determine

a second discriminant equation that discriminates between the patients with the first state of autonomic function from the additional population of patients and the patients with the second state of autonomic function from the additional population of patients;

storing the second discriminant equation in the one or more memories;

accessing the second discriminant equation; and

entering the physiologic data from the new patient into the second discriminant equation to produce a second autonomic ranking, wherein the second autonomic ranking is indicative of an alternative autonomic function of the individual patient.

39. The method of claim 38 further comprising the step of indicating if the second autonomic ranking differs by a predetermined amount from the first autonomic ranking.

40. The method of claim 35 further comprising the step of displaying the first and second autonomic rankings in proximity to each other.

41. The method of claim 35 further comprising:

receiving additional physiologic data from the new patient;

entering the additional physiologic data from the new patient into the first discriminant equation to produce a second autonomic ranking, wherein the second autonomic ranking is indicative of an alternative autonomic function of the new patient.

42. The method of claim 41 further comprising the step of indicating if the second autonomic ranking differs by a predetermined amount from the first autonomic ranking.

43. The method of claim 41 further comprising the step of displaying the first and second autonomic rankings in proximity to each other.

44. One or more program storage media readable by a machine and containing instructions for performing the method contained in claim 35.

45. The method of claim 30 wherein the population of patients is further comprised of non-human patients.

46. A method of assessing autonomic function comprising:

receiving background data from a population of patients wherein the population of patients is comprised of patients with abnormal autonomic function and patients with normal autonomic function;

receiving ECG data from the population of patients;

measuring the ECG data from the population of patients to obtain one or more HRV parameters from the population of patients wherein the one or more HRV parameters from the population of patients are selected from the group consisting of: 30:15 Ratio, NNmin Standing, NNmax Standing, Tmax, Trec, E/I Ratio, SD, NNmin SB, NNmax SB, VARmax, VARmean, RMS-SD, NN, SDNN, TP, LFnorm, HFnorm, LF/HF, VLF, LF, HF, VR and combinations thereof;

performing statistical discriminant analysis on the one or more HRV parameters from the population of patients and the background data from the population of patients to determine a plurality of discriminant equations wherein each discriminant equation discriminates

- between the patients with abnormal autonomic function and the patients with normal autonomic function;
- receiving background data from a new patient;
- receiving ECG data from the new patient;
- measuring the ECG data from the new patient to obtain one or more HRV parameters from the new patient wherein the one or more HRV parameters are selected from the group consisting of: 30:15 Ratio, NNmin Standing, NNmax Standing, Tmax, Trec, E/I Ratio, SD, NNmin SB, NNmax SB, VARmax, VARmean, RMS-SD, NN, SDNN, TP, LFnorm, HFnorm, LF/HF, VLF, LF, HF, VR and combinations thereof;
- selecting a discriminant equation from the plurality of discriminant equations in response to the background data from the new patient;
- inputting the one or more HRV parameters from the new patient into the selected discriminant equation to provide an autonomic ranking that is indicative of an autonomic function of the new patient.
- 47.** One or more program storage media readable by a machine and containing instructions for performing the method contained in claim 46.
- 48.** A method for assessing autonomic function comprising:
- receiving HRV data from a patient that comprises at least one HRV measurement;
- inputting the HRV data into a first discriminant equation to provide a first autonomic ranking that is indicative of an autonomic function of the patient, wherein the first discriminant equation discriminates between a first group of patients with a first state of autonomic function and a second group of patients with a second state of autonomic function.
- 49.** The method of claim 48 wherein the HRV data comprises at least two HRV measurements.
- 50.** The method of claim 48 wherein the HRV measurement is selected from the group consisting of: 30:15 Ratio, NNmin Standing, NNmax Standing, Tmax, Trec and combinations thereof.
- 51.** The method of claim 48 wherein the HRV measurement is selected from group consisting of: E/I Ratio, SD, NNmin SB, NNmax SB, VARmax, VARmean and combinations thereof.
- 52.** The method of claim 48 wherein the HRV measurement is selected from group consisting of: RMS-SD, NN, SDNN, TP, LFnorm, HFnorm, LF/HF, VLF, LF, HF and combinations thereof.
- 53.** The method of claim 48 further comprising the step of inputting the HRV data into a second discriminant equation to provide a second autonomic ranking that is indicative of an alternative autonomic function of the patient, wherein the second discriminant equation discriminates between a third group of patients with a first state of autonomic function and a fourth group of patients with a second state of autonomic function.
- 54.** The method of claim 48 further comprising the following steps:
- receiving additional HRV data from the patient that comprises at least one HRV measurement; and
- inputting the additional HRV data into a second discriminant equation to provide a second autonomic ranking that is indicative of an alternative autonomic function of the patient, wherein the second discriminant equation discriminates between a third group of patients with a first state of autonomic function and a fourth group of patients with a second state of autonomic function.
- 55.** The method of claim 48 further comprising the following steps:
- receiving additional HRV data from the patient that comprises at least one HRV measurement; and
- inputting the additional HRV data into the first discriminant equation to produce a second autonomic ranking, wherein the second autonomic ranking is indicative of an alternative autonomic function of the new patient.
- 56.** One or more program storage media readable by a machine and containing instructions for performing the method contained in claim 48.
- 57.** One or more computer program products, having one or more computer readable mediums with computer program logic recorded thereon, for assessing autonomic function, comprising:
- programming operable for receiving background data from a population of patients wherein the population of patients is comprised of a first group of patients with a first state of autonomic function and a second group of patients with a second state of autonomic function;
- programming operable for receiving physiologic data from the population of patients;
- programming operable for determining from the physiologic data and the background data a first discriminant equation that discriminates between the first group of patients with the first state of autonomic function and the second group of patients with the second state of autonomic function;
- programming operable for receiving physiologic data from a new patient; and
- programming operable for inputting the physiologic data from the new patient into the first discriminant equation to provide a first autonomic ranking that is indicative of an autonomic function of the new patient.
- 58.** The one or more computer program products of claim 57 wherein the physiologic data from the population of patients comprises at least one HRV measurement; wherein the HRV measurement is selected from the group consisting of: 30:15 Ratio, NNmin Standing, NNmax Standing, Tmax, Trec, E/I Ratio, SD, NNmin SB, NNmax SB, VARmax, VARmean, RMS-SD, NN, SDNN, TP, LFnorm, HFnorm, LF/HF, VLF, LF, HF, VR and combinations thereof.
- 59.** The one or more computer program products of claim 57 wherein the physiologic data from the new patient comprised at least one HRV measurement; wherein the HRV measurement is selected from the group consisting of: 30:15 Ratio, NNmin Standing, NNmax Standing, Tmax, Trec, E/I Ratio, SD, NNmin SB, NNmax SB, VARmax, VARmean, RMS-SD, NN, SDNN, TP, LFnorm, HFnorm, LF/HF, VLF, LF, HF, VR and combinations thereof.
- 60.** The one or more computer program products of claim 57 wherein the background data from the population of

patients includes age and a selection from the group consisting of: race, gender, smoker status and health condition.

61. The one or more computer program products of claim 57 further comprising:

programming operable for receiving background data from an additional population of patients wherein the additional population of patients is comprised of a third group of patients with a first state of autonomic function and a fourth group of patients with a second state of autonomic function;

programming operable for receiving physiologic data from the additional population of patients;

programming operable for determining from the physiologic data from the additional population of patients and the background data from the additional population of patients a second discriminant equation that discriminates between the third group of patients with the first state of autonomic function from the additional population of patients and the fourth group of patients with the second state of autonomic function from the additional population of patients; and

programming operable for inputting the physiologic data from the new patient into the second discriminant equation to provide a second autonomic ranking that is indicative of an alternative autonomic function the new patient.

62. The one or more computer program products of claim 61 further comprising programming operable for displaying the first and second autonomic rankings in proximity to each other.

63. The one or more computer program products of claim 57 further comprising:

programming operable for receiving background data from an additional population of patients wherein the additional population of patients is comprised of a third group of patients with a first state of autonomic function and a fourth group of patients with a second state of autonomic function;

programming operable for receiving physiologic data from the additional population of patients;

programming operable for determining from the physiologic data from the additional population of patients and the background data from the additional population of patients a second discriminant equation that discriminates between the third group of patients with the first state of autonomic function from the additional population of patients and the fourth group of patients with the second state of autonomic function from the additional population of patients;

programming operable for receiving additional physiologic data from the new patient; and

programming operable for entering the additional physiologic data from the new patient into the second discriminant equation to produce a second autonomic ranking, wherein the second autonomic ranking is indicative of an alternative autonomic function of the new patient.

64. The one or more computer program products of claim 63 further comprising programming operable for displaying the first and second autonomic rankings in proximity to each other.

65. The one or more computer program products of claim 57 further comprising:

programming operable for receiving additional physiologic data from the new patient; and

programming operable for inputting the additional physiologic data from the new patient into the first discriminant equation to produce a second autonomic ranking, wherein the second autonomic ranking is indicative of an alternative autonomic function of the new patient.

66. The method of claim 65 further comprising programming operable for displaying the first and second autonomic rankings in proximity to each other.

* * * * *

专利名称(译)	用于测量自主神经系统功能的方法和装置		
公开(公告)号	US20050251054A1	公开(公告)日	2005-11-10
申请号	US10/842294	申请日	2004-05-10
[标]申请(专利权)人(译)	MEDPOND		
申请(专利权)人(译)	MEDPOND, LLC		
当前申请(专利权)人(译)	MEDPOND, LLC		
[标]发明人	ZHIRNOV YEVGENIY N POUGATCHEV VADIM I GRIBKOV EVGUENI N FERRIS MARK		
发明人	ZHIRNOV, YEVGENIY N. POUGATCHEV, VADIM I. GRIBKOV, EVGUENI N. FERRIS, MARK		
IPC分类号	A61B5/00 A61B5/02 A61B5/04 A61B5/0452 A61B5/08 A61B10/00 G06K9/62		
CPC分类号	G06Q50/24 A61B5/0452 A61B5/4035 G16H50/70 Y10S128/92		
外部链接	Espacenet USPTO		

摘要(译)

本发明分析患者群体内的因素之间的关系，以识别自主神经功能障碍模式。然后将患者测试结果与所识别的模式进行比较以确定患者的自主功能。本发明可以用新的测试结果连续地修改患者群体，以创建越来越准确的标准化数据集，从中可以更准确地评估患者的自主功能。本发明可以将该概念应用于应用服务提供商模型中。本发明的实施例可以使用识别ECG R波的新方法。该方法通过在信号中搜索超过阈值的最大斜率值来定位R波。本发明的另一个实施例需要非挑衅性HRV测试，由此分析某些时域和频域因子以确定患者的自主神经功能。

