



US008214035B2

(12) **United States Patent**  
**Giftakis et al.**

(10) **Patent No.:** **US 8,214,035 B2**  
(45) **Date of Patent:** **Jul. 3, 2012**

(54) **SYSTEM AND METHOD FOR UTILIZING  
BRAIN STATE INFORMATION TO  
MODULATE CARDIAC THERAPY**

(58) **Field of Classification Search** ..... 607/6, 9;  
600/301  
See application file for complete search history.

(75) Inventors: **Jonathon E. Giftakis**, Maple Grove,  
MN (US); **Nina M. Graves**,  
Minnetonka, MN (US); **Jonathan C.  
Werder**, Corcoran, MN (US); **Eric J.  
Panken**, Edina, MN (US)

(56) **References Cited**

U.S. PATENT DOCUMENTS

4,374,382	A	2/1983	Markowitz
4,485,813	A	12/1984	Anderson et al.
4,495,950	A	1/1985	Schneider
4,503,857	A	3/1985	Boute et al.
4,556,063	A	12/1985	Thompson et al.
4,567,892	A	2/1986	Plicchi et al.
4,596,251	A	6/1986	Plicchi et al.
4,702,254	A	10/1987	Zabara
4,862,144	A	8/1989	Tao
4,867,164	A	9/1989	Zabara
4,903,701	A	2/1990	Moore et al.
4,987,897	A	1/1991	Funke

(Continued)

FOREIGN PATENT DOCUMENTS

EP 0512577 11/1992  
(Continued)

OTHER PUBLICATIONS

U.S. Appl. No. 11/766,886 Notice of Allowance mailed Sep. 23,  
2011, 3 pages.

(Continued)

*Primary Examiner* — Nicole F Lavert

(57) **ABSTRACT**

A system for regulating or modulating cardiac therapy using brain state information. The modulation may include suppressing standard, prescribed cardiac therapy for a period of time or it may involve modulating the type of cardiac therapy delivered. In another embodiment, a system is provided for determining whether a cardiac event is categorized as neurologically matched, and, if so, modulating the therapeutic output to the heart.

**21 Claims, 53 Drawing Sheets**

(73) Assignee: **Medtronic, Inc.**, Minneapolis, MN (US)

(\* ) Notice: Subject to any disclaimer, the term of this patent is extended or adjusted under 35 U.S.C. 154(b) by 1142 days.

(21) Appl. No.: **11/796,575**

(22) Filed: **Apr. 27, 2007**

(65) **Prior Publication Data**

US 2007/0260286 A1 Nov. 8, 2007

**Related U.S. Application Data**

(63) Continuation-in-part of application No. 11/311,043, filed on Dec. 19, 2005, now Pat. No. 7,865,244, and a continuation-in-part of application No. 11/311,200, filed on Dec. 19, 2005, now Pat. No. 8,041,418, and a continuation-in-part of application No. 11/311,393, filed on Dec. 19, 2005, now Pat. No. 8,041,419, and a continuation-in-part of application No. 11/311,456, filed on Dec. 19, 2005, now Pat. No. 7,945,316.

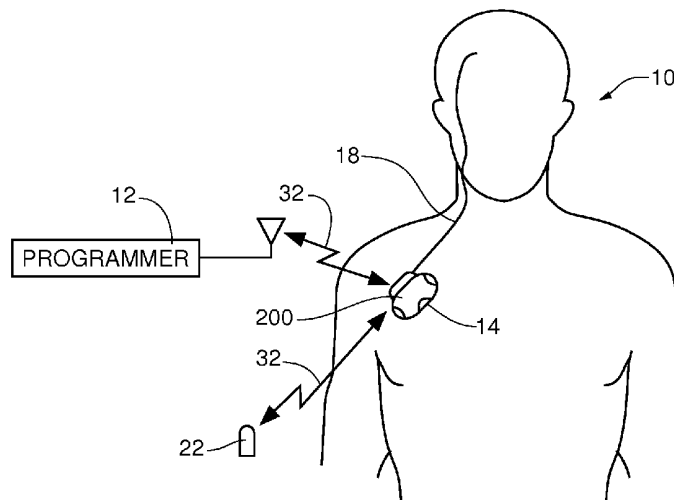
(60) Provisional application No. 60/636,929, filed on Dec. 17, 2004.

(51) **Int. Cl.**

**A61N 1/00** (2006.01)

**A61B 5/00** (2006.01)

(52) **U.S. Cl.** ..... **607/9; 607/6; 600/301**



U.S. PATENT DOCUMENTS

5,003,976 A	4/1991	Alt	7,103,412 B1	9/2006	Kroll
5,025,807 A	6/1991	Zabara	7,146,218 B2	12/2006	Esteller et al.
5,052,388 A	10/1991	Sivula et al.	7,162,304 B1	1/2007	Bradley
5,113,859 A	5/1992	Funke	7,174,206 B2	2/2007	Frei et al.
5,127,404 A	7/1992	Wyborny et al.	7,177,674 B2	2/2007	Echaz et al.
5,168,759 A	12/1992	Bowman	7,207,948 B2	4/2007	Coyle
5,203,326 A	4/1993	Collins	7,242,983 B2	7/2007	Frei et al.
5,271,395 A	12/1993	Wahlstrand et al.	7,324,845 B2	1/2008	Mietus et al.
5,312,451 A	5/1994	Limousin et al.	2001/0051819 A1	12/2001	Fischell
5,314,430 A	5/1994	Bardy	2002/0072778 A1	6/2002	Guck
5,336,244 A	8/1994	Weijand	2002/0099412 A1	7/2002	Fischell et al.
5,354,316 A	10/1994	Keimel	2002/0107553 A1	8/2002	Hill et al.
5,354,318 A	10/1994	Taepke	2002/0169485 A1	11/2002	Pless et al.
5,409,009 A	4/1995	Olson	2003/0004548 A1	1/2003	Warkentin
5,509,927 A	4/1996	Epstein et al.	2003/0073917 A1	4/2003	Echaz et al.
5,545,186 A	8/1996	Olson et al.	2003/0083716 A1	5/2003	Nicolelis et al.
5,554,177 A	9/1996	Kieval et al.	2003/0149457 A1	8/2003	Tcheng et al.
5,560,368 A	10/1996	Berger	2003/0195574 A1	10/2003	Osorio et al.
5,562,711 A	10/1996	Yerich et al.	2003/0195588 A1	10/2003	Fischell et al.
5,626,622 A	5/1997	Cooper	2003/0236474 A1	12/2003	Singh
5,645,068 A	7/1997	Mezack et al.	2004/0006264 A1	1/2004	Mojarradi et al.
5,683,432 A	11/1997	Goedeke et al.	2004/0102816 A1	5/2004	Mazar
5,684,460 A	11/1997	Scanlon	2004/0116974 A1	6/2004	Obel
5,713,923 A	2/1998	Ward et al.	2004/0133119 A1	7/2004	Osorio et al.
5,749,900 A	5/1998	Schroeppe et al.	2004/0133120 A1	7/2004	Frei et al.
5,752,976 A	5/1998	Duffin et al.	2004/0133248 A1	7/2004	Frei et al.
5,782,891 A	7/1998	Hassler et al.	2004/0133390 A1	7/2004	Osorio et al.
5,836,988 A	11/1998	Cooper et al.	2004/0138516 A1	7/2004	Osorio et al.
5,871,517 A	2/1999	Abrams et al.	2004/0138517 A1	7/2004	Osorio et al.
5,928,272 A	7/1999	Adkins et al.	2004/0138518 A1	7/2004	Rise et al.
5,987,352 A	11/1999	Klein et al.	2004/0138536 A1	7/2004	Frei et al.
5,995,868 A	11/1999	Dorfmeister et al.	2004/0138580 A1	7/2004	Frei et al.
6,029,087 A	2/2000	Wohlgemuth	2004/0138581 A1	7/2004	Frei et al.
6,035,233 A	3/2000	Schroeppe et al.	2004/0138647 A1	7/2004	Osorio et al.
6,067,473 A	5/2000	Greeninger et al.	2004/0138711 A1	7/2004	Osorio et al.
6,083,248 A	7/2000	Thompson	2004/0138721 A1	7/2004	Osorio et al.
6,115,630 A	9/2000	Stadler et al.	2004/0152958 A1	8/2004	Frei et al.
6,128,526 A	10/2000	Stadler et al.	2004/0158119 A1	8/2004	Osorio et al.
6,134,474 A	10/2000	Fischell et al.	2004/0176817 A1	9/2004	Wahlstrand et al.
6,155,267 A	12/2000	Nelson	2004/0181263 A1	9/2004	Balzer et al.
6,185,459 B1	2/2001	Mehra et al.	2004/0199482 A1	10/2004	Wilson
6,200,265 B1	3/2001	Walsh et al.	2004/0215240 A1	10/2004	Lovett
6,263,237 B1	7/2001	Rise	2004/0230105 A1 *	11/2004	Geva et al. .... 600/301
6,280,461 B1	8/2001	Glegyak et al.	2004/0267152 A1	12/2004	Pineda
6,337,997 B1	1/2002	Rise	2005/0010265 A1	1/2005	Baru Fassio et al.
6,341,236 B1	1/2002	Osorio et al.	2005/0081847 A1 *	4/2005	Lee et al. .... 128/200.24
6,353,754 B1	3/2002	Fischell et al.	2005/0115561 A1	6/2005	Stahmann et al.
6,360,122 B1	3/2002	Fischell et al.	2005/0197590 A1	9/2005	Osorio et al.
6,363,274 B1	3/2002	Fischell et al.	2005/0216071 A1	9/2005	Devlin et al.
6,366,813 B1	4/2002	DiLorenzo	2006/0058856 A1	3/2006	Morell
6,415,174 B1	7/2002	Bebehani et al.	2006/0094970 A1	5/2006	Drew
6,427,086 B1	7/2002	Fischell et al.	2006/0094972 A1	5/2006	Drew
6,463,328 B1	10/2002	John	2006/0135877 A1	6/2006	Giftakis et al.
6,466,822 B1	10/2002	Pless	2006/0135881 A1	6/2006	Giftakis et al.
6,473,639 B1	10/2002	Fischell et al.	2006/0136006 A1	6/2006	Giftakis et al.
6,480,743 B1	11/2002	Kirkpatrick et al.	2006/0195144 A1	8/2006	Giftakis et al.
6,496,175 B1	12/2002	Fukuo	2006/0206159 A1	9/2006	Moffitt
6,496,715 B1	12/2002	Lee et al.	2006/0224067 A1	10/2006	Giftakis et al.
6,505,067 B1	1/2003	Lee et al.	2006/0241725 A1	10/2006	Libbus et al.
6,512,940 B1	1/2003	Brabec et al.	2007/0100392 A1	5/2007	Maschino
6,512,949 B1	1/2003	Combs et al.	2007/0161919 A1	7/2007	DiLorenzo
6,522,915 B1	2/2003	Ceballos et al.	2007/0238939 A1	10/2007	Giftakis
6,549,804 B1	4/2003	Osorio et al.	2007/0239054 A1	10/2007	Giftakis
6,556,859 B1	4/2003	Wohlgemuth et al.	2007/0239060 A1	10/2007	Giftakis
6,572,542 B1	6/2003	Houben et al.	2007/0239230 A1	10/2007	Giftakis
6,587,727 B2	7/2003	Osorio et al.	2007/0260147 A1	11/2007	Giftakis
6,622,036 B1	9/2003	Suffin	2007/0260289 A1	11/2007	Giftakis
6,647,292 B1	11/2003	Bardy et al.	2007/0265536 A1	11/2007	Giftakis
6,650,938 B2	11/2003	Boute	2007/0265677 A1	11/2007	Giftakis
6,656,125 B2	12/2003	Misczynski	2008/0033490 A1	2/2008	Giftakis
6,671,555 B2	12/2003	Gielen et al.	2008/0269842 A1	10/2008	Giftakis
6,671,556 B2	12/2003	Osorio et al.			
6,719,701 B2	4/2004	Lade			
6,721,599 B2	4/2004	De Vries			
6,745,076 B2	6/2004	Wohlgemuth et al.	WO	02/34332	5/2002
6,920,357 B2	7/2005	Osorio et al.	WO	WO 02/36003	5/2002
6,934,580 B1	8/2005	Osorio et al.	WO	WO 02/49500	6/2002
6,961,618 B2	11/2005	Osorio et al.	WO	2004/091720	10/2004
			WO	WO 9726823	8/2008

FOREIGN PATENT DOCUMENTS

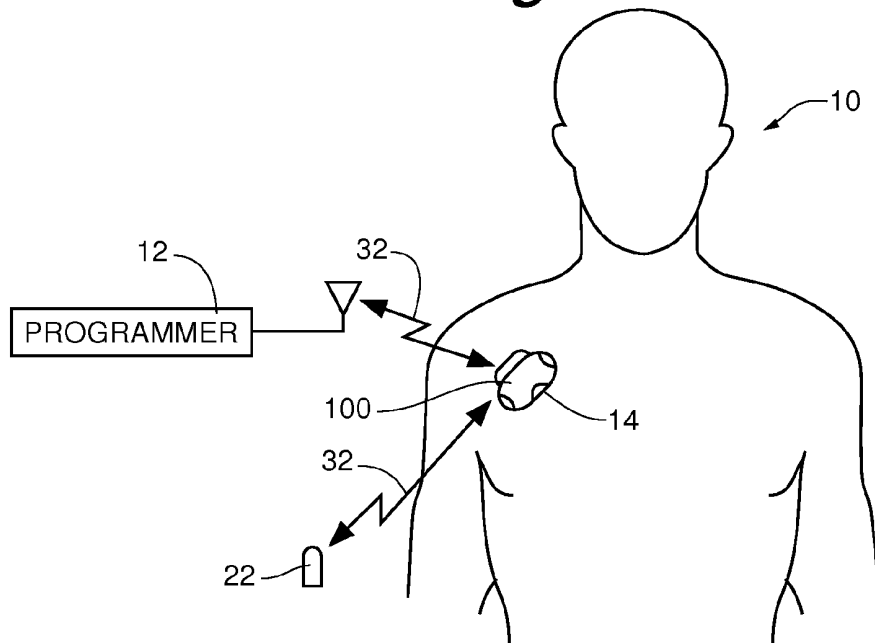
## OTHER PUBLICATIONS

- U.S. Appl. No. 11/380,462 Notice of Allowance mailed Sep. 27, 2011, 3 pgs.
- U.S. Appl. No. 11/741,103 Notice of Allowance mailed Sep. 28, 2011, 3 pages.
- U.S. Appl. No. 11/767,054 Notice of Allowance mailed Nov. 15, 2011, 3 pgs.
- U.S. Appl. No. 11/741,119 Final Office Action mailed Dec. 22, 2011, 32 pages.
- U.S. Appl. No. 11/741,119 Advisory Action mailed Mar. 8, 2012, 3 pages.
- Notification of Transmittal of the International Search and the Written Opinion, dated Jan. 7, 2008 for corresponding PCT Application No. PCT/US2007/067625 (15 pages).
- U.S. Appl. No. 11/380,462 Non Final Office Action mailed Apr. 8, 2009, 13 pgs.
- U.S. Appl. No. 11/796,382 Notice of Allowance mailed Mar. 2, 2011, 7 pages.
- U.S. Appl. No. 11/741,119 Office Action mailed Mar. 28, 2011, 28 pages.
- U.S. Appl. No. 11/796,576 Final Office Action mailed Mar. 30, 2011, 10 pages.
- U.S. Appl. No. 11/766,886 Office Action mailed Apr. 11, 2011, 10 pgs.
- U.S. Appl. No. 11/741,109 Final Office Action mailed Apr. 12, 2011, 8 pgs.
- U.S. Appl. No. 11/380,462 Office Action mailed Apr. 13, 2011, 7 pgs.
- U.S. Appl. No. 11/741,103 Office Action mailed Apr. 13, 2011, 10 pgs.
- U.S. Appl. No. 11/796,577 Notice of Allowance mailed May 5, 2011, 13 pgs.
- U.S. Appl. No. 11/311,200 Notice of Allowance mailed Dec. 5, 2009, 3 pgs.
- U.S. Appl. No. 11/311,043 Notice of Allowance mailed Dec. 21, 2009, 1 pgs.
- U.S. Appl. No. 11/796,576 Office Action mailed Jan. 8, 2010, 7 pgs.
- U.S. Appl. No. 11/796,577 Office Action mailed Mar. 9, 2010, 8 pgs.
- U.S. Appl. No. 11/380,462 Office Action mailed Mar. 15, 2010, 12 pgs.
- U.S. Appl. No. 11/311,043 Notice of Allowance mailed May 5, 2010, 4 pgs.
- U.S. Appl. No. 11/311,200 Notice of Allowance mailed Apr. 20, 2010, 1 pgs.
- U.S. Appl. No. 11/796,382 Office Action mailed May 20, 2010, 10 pages.
- U.S. Appl. No. 11/311,456 Office Action mailed May 28, 2010, 11 pages.
- U.S. Appl. No. 11/311,393 Office Action mailed Jun. 4, 2010, 10 pages.
- U.S. Appl. No. 11/311,200 Office Communication mailed Jul. 26, 2010, 6 pgs.
- Vaughn, et al., "Monitoring Heart Period Variability changes During Seizures. II. Diversity and Trends", *J. Epilepsy*, 1996, p. 27-34, vol. 9.
- Pacemaker Stops Epilepsy Deaths, Dec. 2004, BBC News World Edition.
- Jones, et al., Heart Rate Responses to Selective Stimulation of Cardiac Vagal C Fibres in Anaesthetized Cats, Rats and Rabbits, 1995, pp. 203-214, *J. Physiol.* 489.1, London.
- Asconape et al., Early Experience with Vagus Nerve Stimulation for the Treatment of Epilepsy: Cardiac Complications, No. 6.058—Abstract from American Epilepsy Society, *Epilepsia*, 1998, vol. 39, Supp. 6.
- Kamath, et al., Neurocardiac responses to Vagoafferent Electrostimulation in Humans, 1992, pp. 1581-1687, *PACE*, vol. 15.
- U.S. Appl. No. 10/997,540, filed Nov. 24, 2004 entitled "A Method and System for Logging Quantitative Seizure Information and Assessing Efficacy of Therapy Using Cardiac Signals".
- International Search and the Written Opinion, dated May 3, 2006 for PCT Application No. PCT/US2005/045656 (8 pages).
- International Search and the Written Opinion, dated May 3, 2006 for PCT Application No. PCT/US2005/045648 (8 pages).
- International Search and the Written Opinion, dated May 8, 2006 for PCT Application No. PCT/US2005/047628 (7 pages).
- International Search and the Written Opinion, dated May 8, 2006 for PCT Application No. PCT/US2005/045902 (8 pages).
- International Search and the Written Opinion, dated May 8, 2006 for PCT Application No. PCT/US2007/067625 (13 pages).
- U.S. Appl. No. 11/767,054 Office Action mailed Jun. 15, 2011, 10 pgs.
- U.S. Appl. No. 11/311,393 Notice of Allowance mailed Jun. 13, 2011, 4 pgs.
- U.S. Appl. No. 11/311,200 Notice of Allowance mailed Jun. 13, 2011, 3 pages.
- U.S. Appl. No. 11/741,109 Notice of Allowance mailed Jul. 5, 2011, 3 pages.
- U.S. Appl. No. 11/796,576 Office Action mailed Jul. 8, 2011, 7 pages.
- U.S. Appl. No. 11/311,043 Non Final Office Action mailed Dec. 23, 2008, 8 pgs.
- U.S. Appl. No. 11/796,576 Non Final Office Action mailed Jun. 17, 2009, 8 pgs.
- U.S. Appl. No. 11/311,043 Notice of Allowance mailed Aug. 10, 2009, 4 pgs.
- U.S. Appl. No. 11/311,200 Non Final Office Action mailed Aug. 25, 2009, 7 pgs.
- U.S. Appl. No. 11/796,382 Non Final Office Action mailed Nov. 23, 2009, 30 pgs.
- U.S. Appl. No. 11/380,462 Final Office Action mailed Nov. 9, 2009, 12 pgs.
- Frei MG, Osorio I. Left vagus nerve stimulation with the neurocybernetic prosthesis has complex effects on heart rate and on its variability in humans. *Epilepsia*. Aug. 2001;42(8):1007-1016. Presented in part at the American Epilepsy Society Annual Meetings San Francisco, CA, 1996, and San Diego, CA, 1998).
- Sunderam S, Osorio I, Frei MG, Watkins III JF. Stochastic modeling and prediction of experimental seizures in sprague-dawley rats. *J Clin Neurophysiol*. May 2001;18(3):275-282.
- Osorio I, Harrison MAF, Frei MG, Lai YC. Observations on the application of the correlation dimension and correlation integral to the prediction of seizures. *J Clin Neurophysiol*. May 2001;18(3):269-274.
- Ingram J, Sunderam S, Frei MG, Osorio, I. Autonomic regulation during complex partial seizures: A thermographic study. Abstract; *Epilepsia*. 41(S7);59. Proceedings of the 54th Annual Meeting of the American Epilepsy Society, Los Angeles, CA, Dec. 1-6, 2000.
- Sunderam S, Watkins III JF, Frei MG, and Osorio I. A stochastic analysis of ictal-interictal transitions during experimental seizures: Seizure duration depends on the duration of preceding ictal and interictal states. Abstract; *Epilepsia*. 41(S7);49. Proceedings of the 54th Annual Meeting of the American Epilepsy Society, Los Angeles, CA, Dec. 1-6, 2000.
- DiTeresi CA, Thompson M, Frei MG, Sunderam S, and Osorio I. Loss of function during partial seizures: A quantitative study in humans. Abstract; *Epilepsia*. 41(S7);237. Proceedings of the 54th Annual Meeting of the American Epilepsy Society, Los Angeles, CA, Dec. 1-6, 2000.
- Nagaraddi V, Wilkinson SB, Osorio I. The effect of one hertz stimulation on kindled seizures in rats. Abstract; Proceeding of the 54th Annual Meeting of the American Epilepsy Society, Los Angeles, CA, Dec. 1-6, 2000.
- Frei MG, Davidchack R, Osorio I. Least squares acceleration filtering for estimating signal derivatives and Sharpness at extrema. *IEEE*. Aug. 1999; 46(8):971-977.
- Osorio I, Frei MG, Wilkinson SB. Real time automated detection and quantitative analysis of seizures and short term predictions of clinical onset. *Epilepsia*. 1998;39(S16):615-627.
- Thomas CV, Angel CA, Watkins JM, Frei MG, Bunag RD, Osorio I. Effects of vagal and sciatic stimulation on 3-MPA-induced seizures in rats. *Epilepsia*. 1998;39(S6):29.
- Frei MG, Haas SM, Ingram JL, Osorio I. Filter design methods for improved seizure detection. *Epilepsia*. 1998;39 (S6):108.
- Powell J, Frei MG, Davidchak R, Watkins JM, Wilkinson SB, Osorio I. Ictal tachycardia does not closely correlate with electrographic onset of ictal ECoG frequency changes. *Epilepsia*. 1998;39(S6):112.

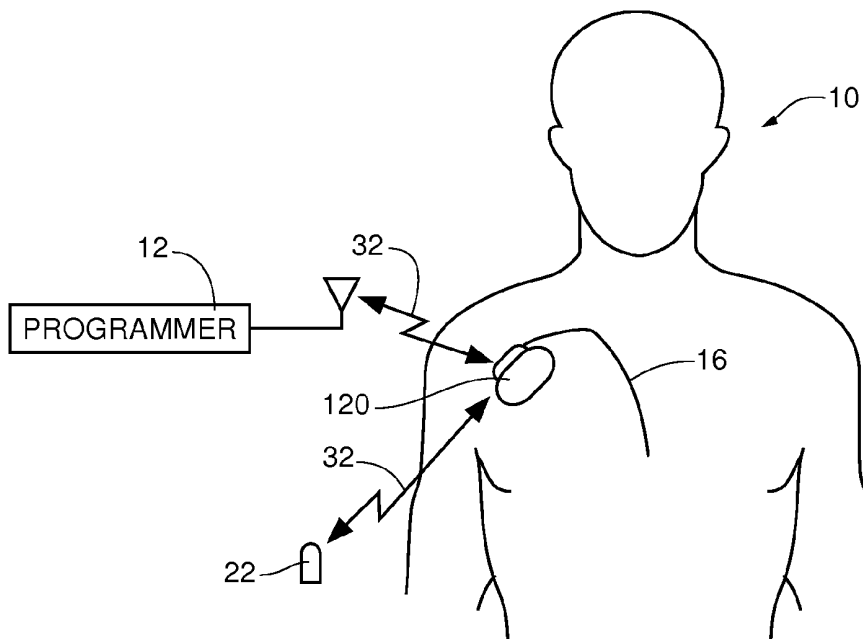
- Frei MG, Davidchack R, Osorio I. Effects of vagal stimulation on human ECG. *Epilepsia*. 1998;39(S6):200.
- Frei MG, Osorio I, Davidchack R. A reappraisal of the value of EKG in the detection of epileptic seizures. Abstract; *Epilepsia*. 1996;37(S5). Poster presentation, 50th Annual Meeting of the American Epilepsy Society, San Francisco, CA., Dec. 8, 1996.
- Han P, Frei MG, Osorio I. Probable mechanisms of action of vagus nerve stimulation in humans with epilepsy: Is the heart a window into the brain? Abstract; *Epilepsia*. 1996;37(S5):83. Platform presentation, 50th Annual Meeting of the American Epilepsy Society, San Francisco, CA, Dec. 8, 1996.
- Frei MG, Osorio I, Wilkinson SB. Quantitative analysis of inter-ictal vs. ictal ECoG signals. Abstract; *Epilepsia*. 1995;36 (S4):5. Poster presentation, 49th Annual Meeting of the American Epilepsy Society, Baltimore, MD, Dec. 4, 1995.
- Osorio I, Frei MG, Lerner D, Wilkinson S. A method for accurate automated real time seizure detection. Abstract; *Epilepsia*. 1995;36(S4):4. Poster presentation, 49th Annual Meeting of the American Epilepsy Society, Baltimore, MD, Dec. 4, 1995.
- Ingram J, Osorio I, Frei MG, Wilkinson SB, Troster A. Temporo-spatial behavior of seizures of temporal lobe origin. Abstract; *Epilepsia*. 1995;36(S4):9. Poster presentation, 49th Annual Meeting of the American Epilepsy Society, Baltimore, MD, Dec. 4, 1995.
- Hayden R, Lerner D, Osorio I, Lai YC, Frei MG. Correlation dimension does not distinguish ictal from interictal activity or noise. Abstract; *Epilepsia*. 1995;36(S4):5. Poster presentation, 49th Annual Meeting of the American Epilepsy Society, Baltimore, MD, Dec. 4, 1995.
- Osorio I, Frei MG, Lerner D, Wilkinson SB. Automated rapid seizure detection in the human ECoG. Abstract in Proceedings of the IEEE Computer-Based Medical Systems, Lubbock, TX, Jun. 9-12, 1995.
- Blum M, Floyd R, Vaughan P, Rivest R, Tarjan R. Linear Time Bounds for Median Computations. Abstract in \*, Aug. 1971.
- Hastad J. Median finding. *Advanced Algorithms*. Lecture 11: May 3, 1995.
- Leutmezer, et al., "Electrocardiographic Changes at Seizure Onset," *Epilepsia*, 2003, pp. 348-354, 44(3).
- Rocamora, et al., "Cardiac Asystole in Epilepsy: Clinical and Neurophysiologic Features," *Epilepsia*, 2003, pp. 179-185, 44(2).
- Tavernor, et al., "Electrocardiograph QT Lengthening Associated with Epileptiform EEG Discharges—a Role in Sudden Unexplained Death in Epilepsy," *Seizure*, Mar. 1996, pp. 79-83, 5(1).
- Devinsky, "Effects of Seizures on Autonomic and Cardiovascular Function," *Epilepsy Currents*, Mar./Apr. 2004, pp. 43-46, 4(2).
- Donner, et al., "Sudden Unexplained Death in Children with Epilepsy," *Neurology*, 2001, pp. 430-434, 57.
- Nei, et al., "EEG and ECG in Sudden Unexplained Death in Epilepsy," *Epilepsia*, 2004, pp. 338-345, 45(4).
- U.S. Appl. No. 11/796,576, Office Action mailed Aug. 20, 2010, 7 pages.
- U.S. Appl. No. 11/741,103, Office Action mailed Aug. 31, 2010, 11 pages.
- U.S. Appl. No. 11/766,886, Office Action mailed Aug. 31, 2010, 11 pages.
- U.S. Appl. No. 11/741,109, Office Action mailed Sep. 29, 2010, 10 pages.
- U.S. Appl. No. 11/311,393, Notice of Allowance, mailed Oct. 1, 2010, 3 pages.
- U.S. Appl. No. 11/380,462, Final Office Action, mailed Nov. 1, 2010, 13 pages.
- U.S. Appl. No. 11/311,456, Notice of Allowance, mailed Oct. 20, 2010, 1 page.
- U.S. Appl. No. 11/311,043, Notice of Allowance, mailed Oct. 19, 2010, 4 pages.
- U.S. Appl. No. 11/311,200, Notice of Allowance, mailed Oct. 12, 2010, 4 pages.
- U.S. Appl. No. 11/796,577, Final Office Action, mailed Nov. 15, 2010, 9 pages.
- U.S. Appl. No. 11/796,382, Final Office Action, mailed Sep. 15, 2010, 10 pages.

\* cited by examiner

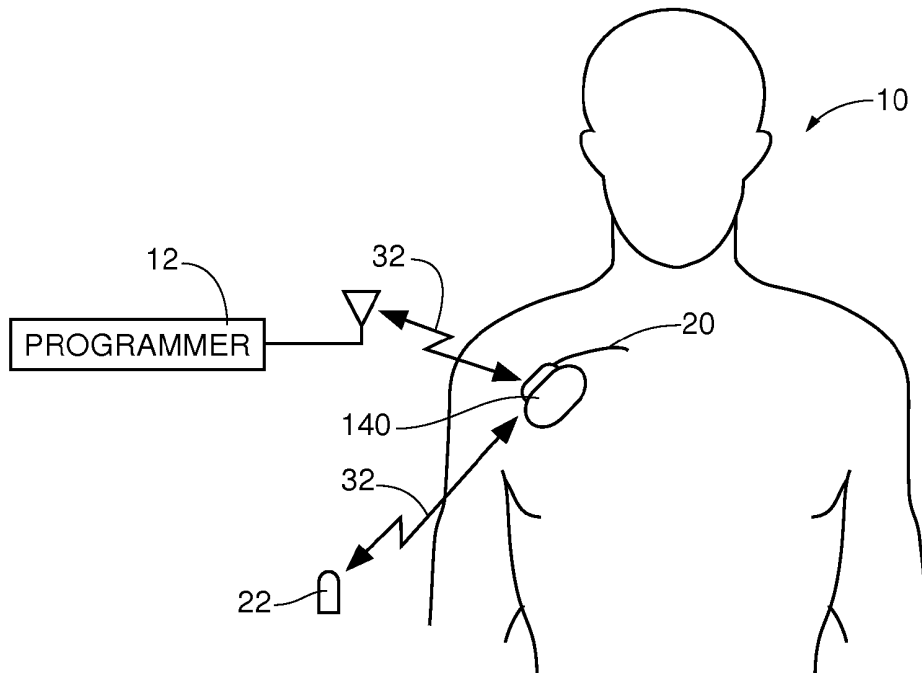
**Fig. 1**



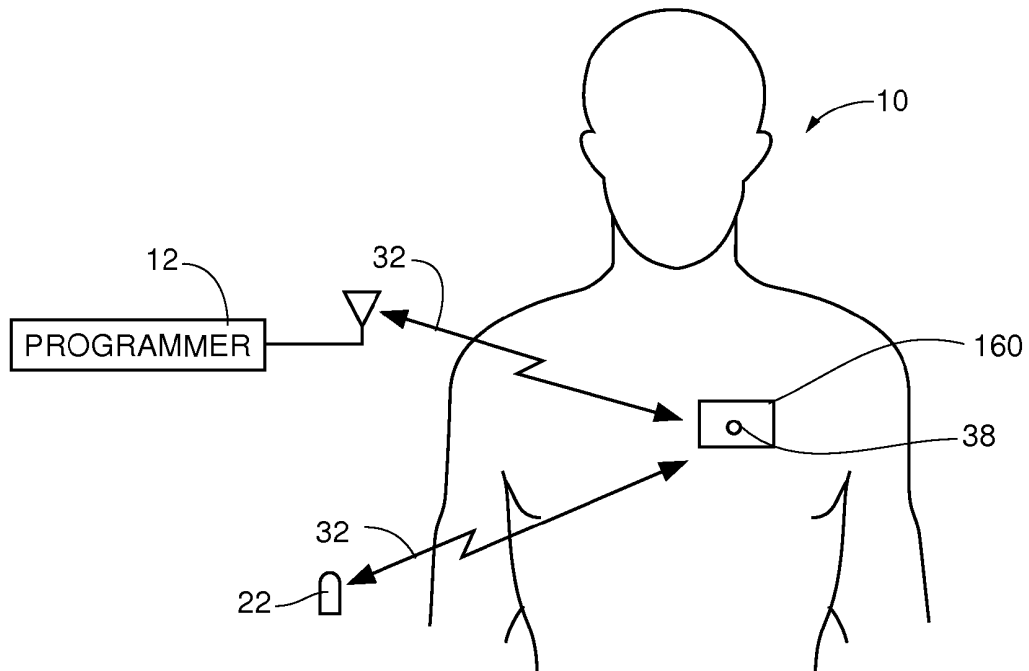
**Fig. 2**



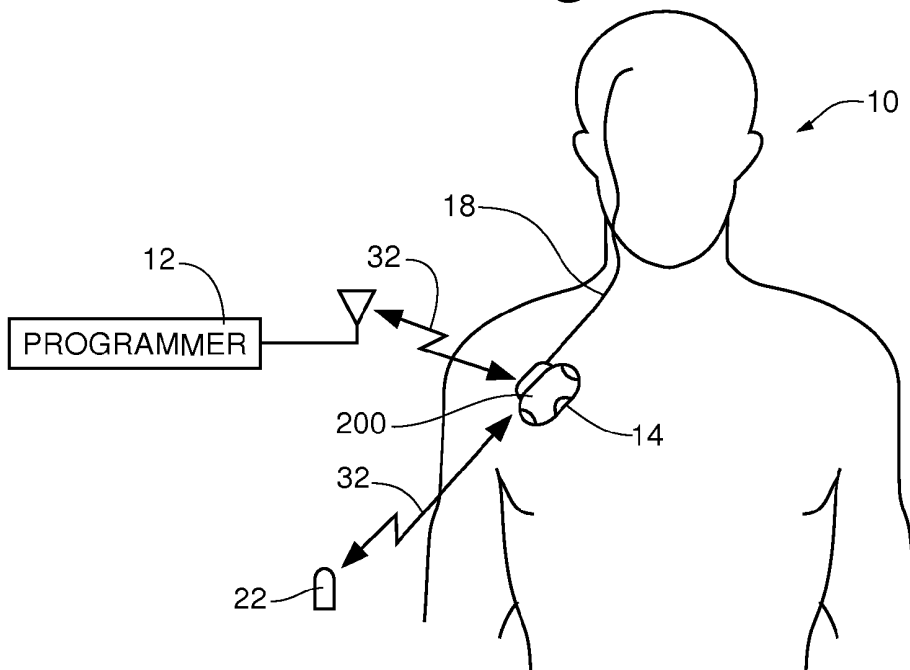
**Fig. 3**



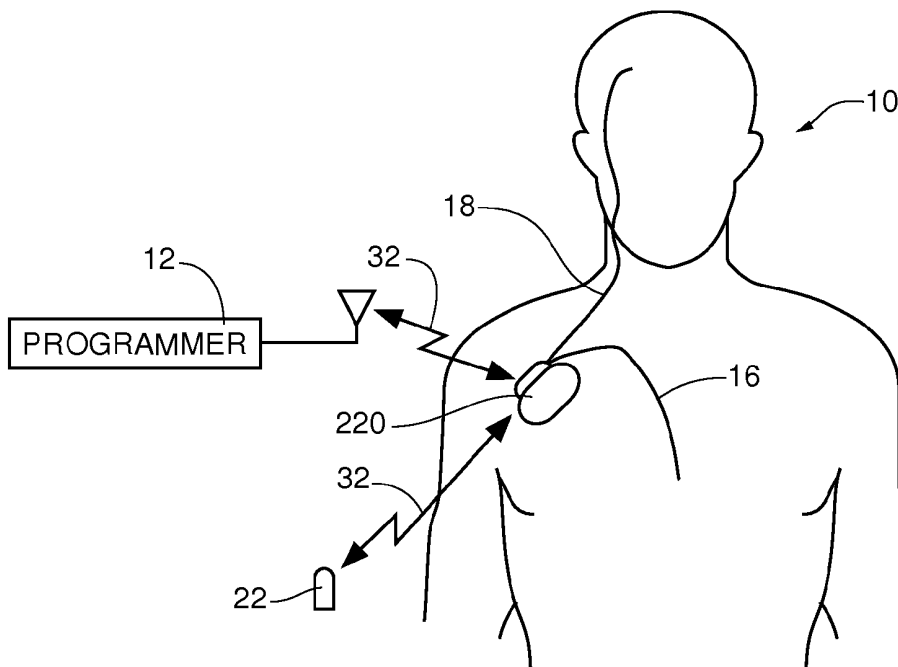
**Fig. 4**



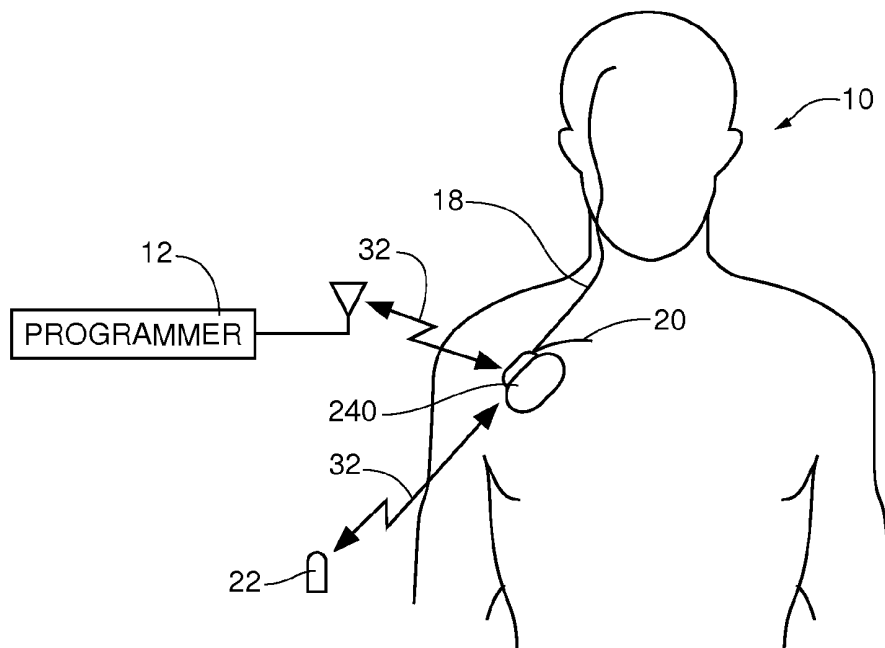
**Fig. 5**



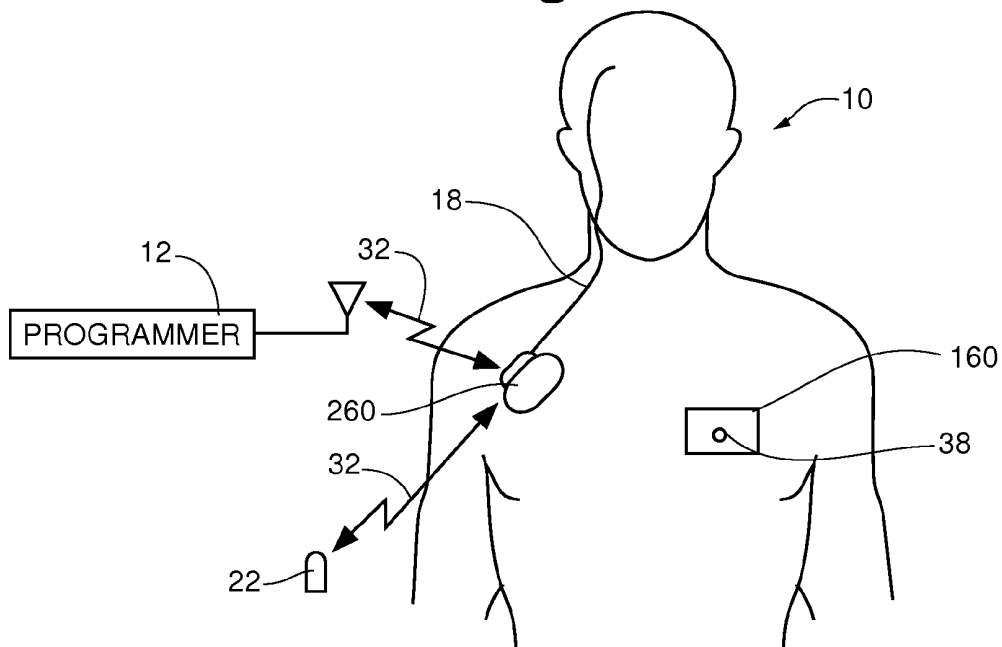
**Fig. 6**



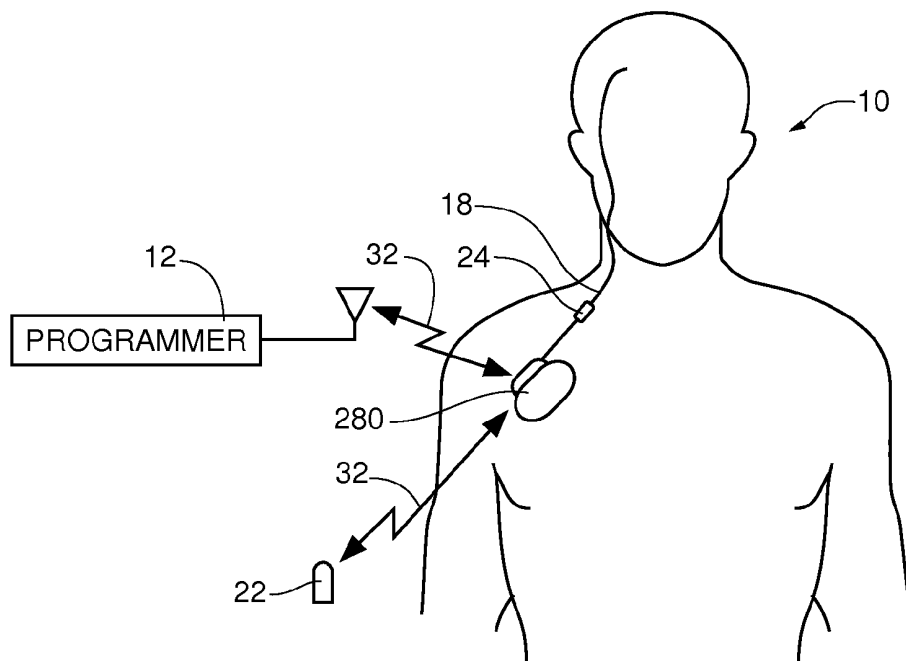
**Fig. 7**



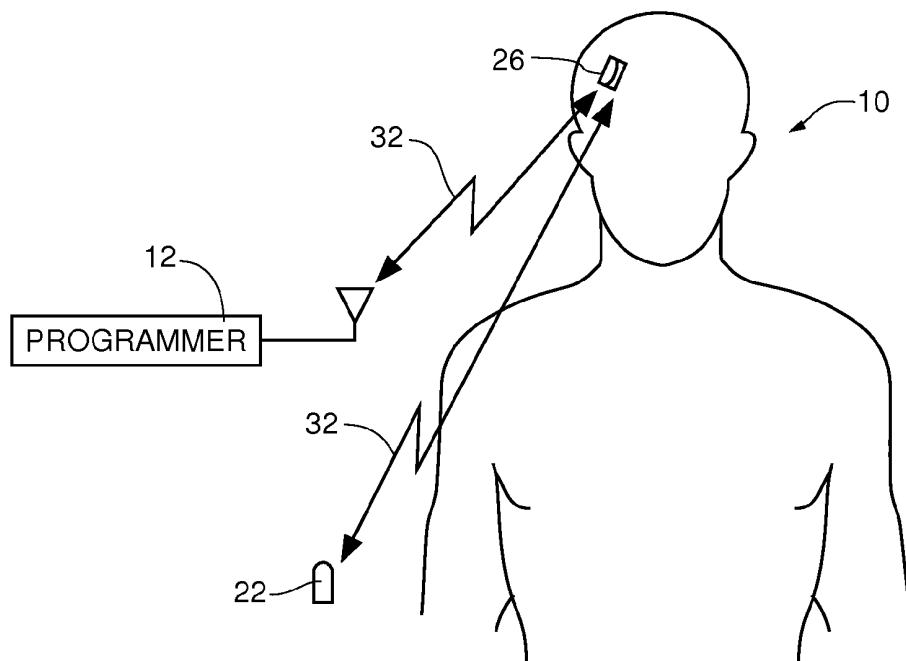
**Fig. 8**



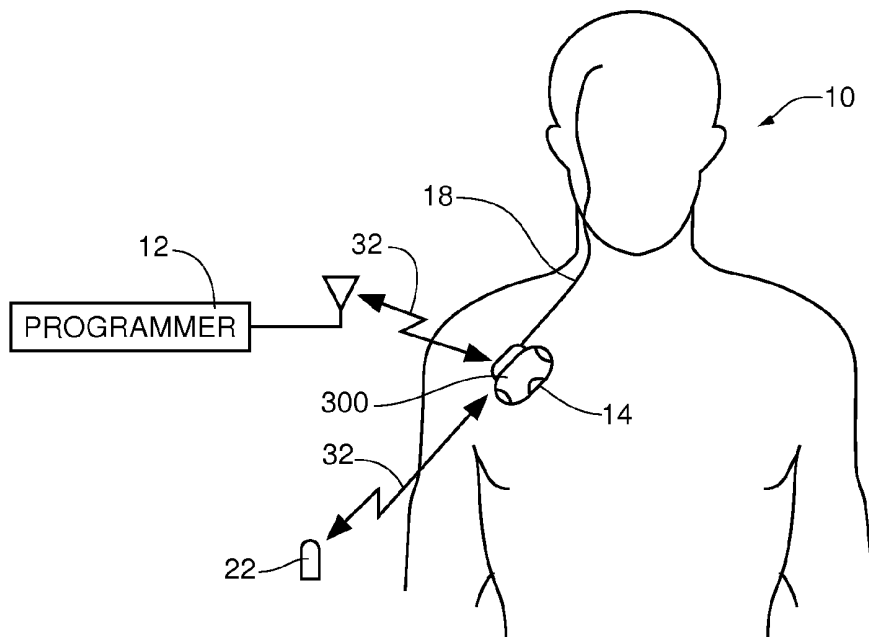
**Fig. 9**



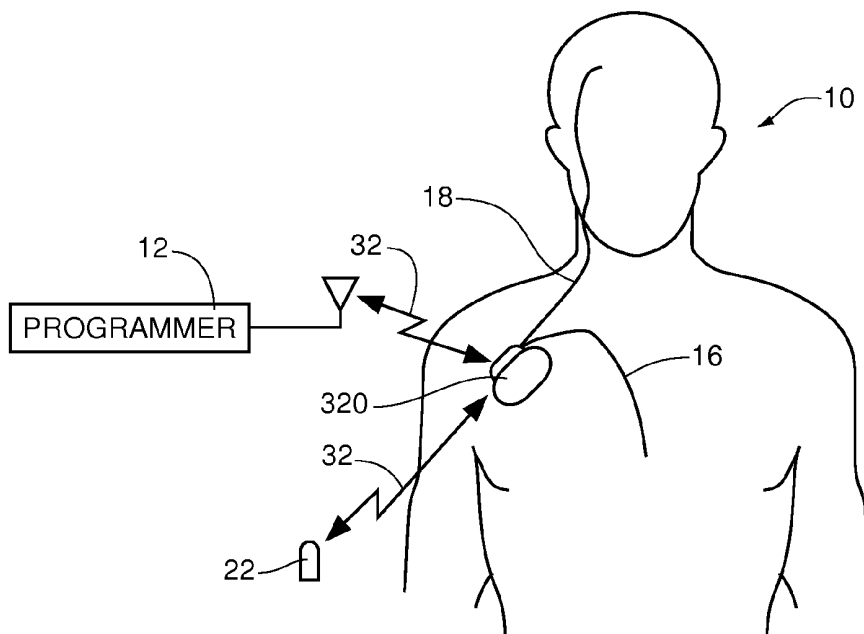
**Fig. 10**



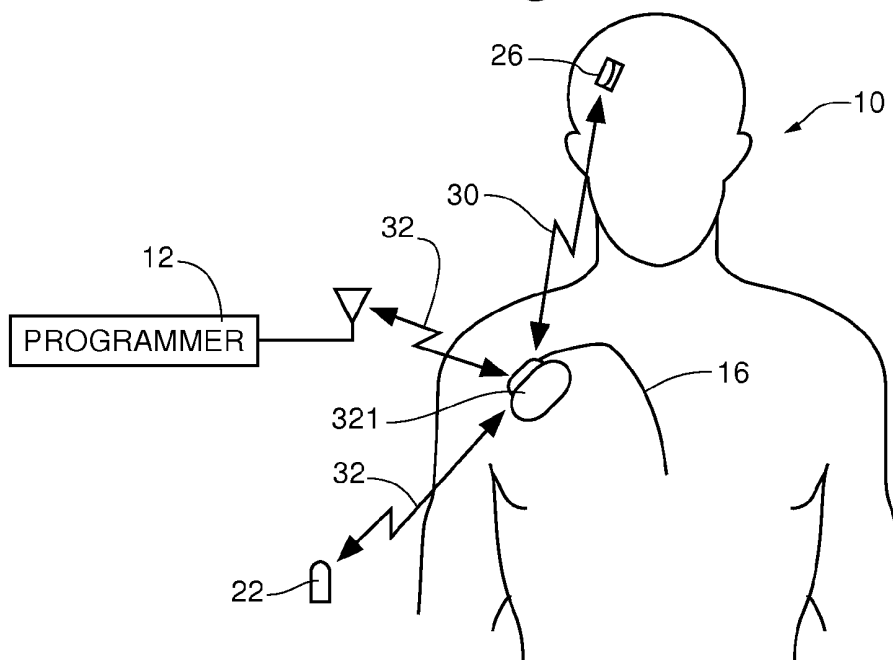
**Fig. 11**



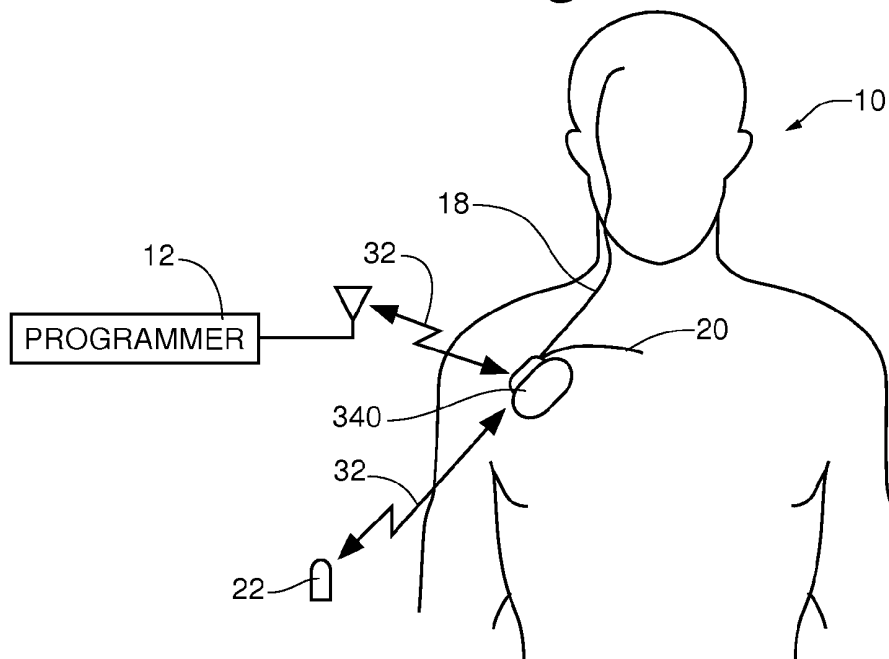
**Fig. 12A**



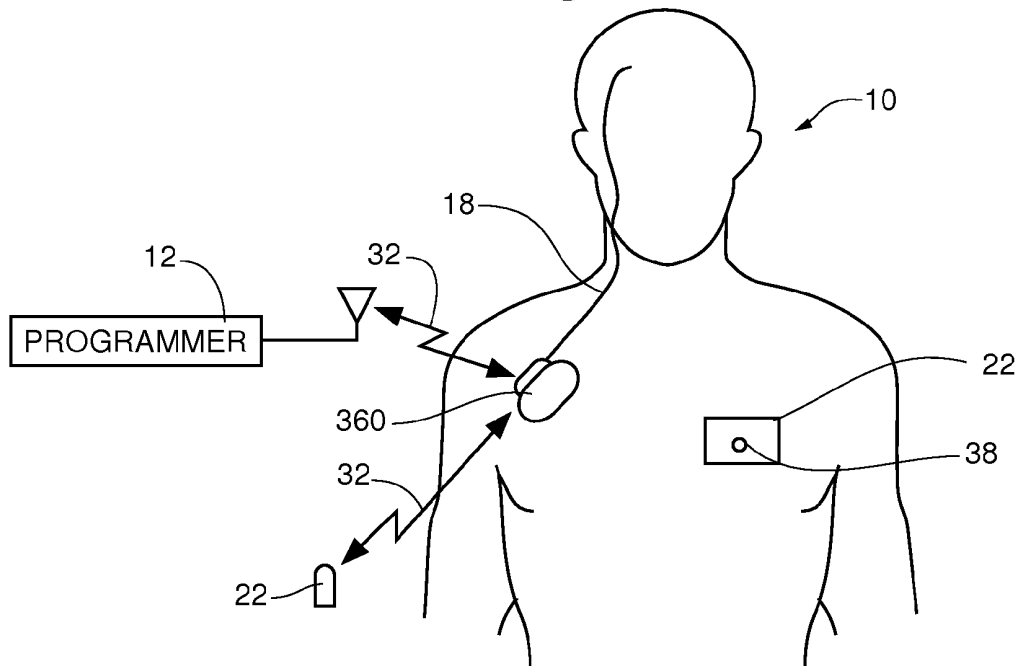
**Fig. 12B**



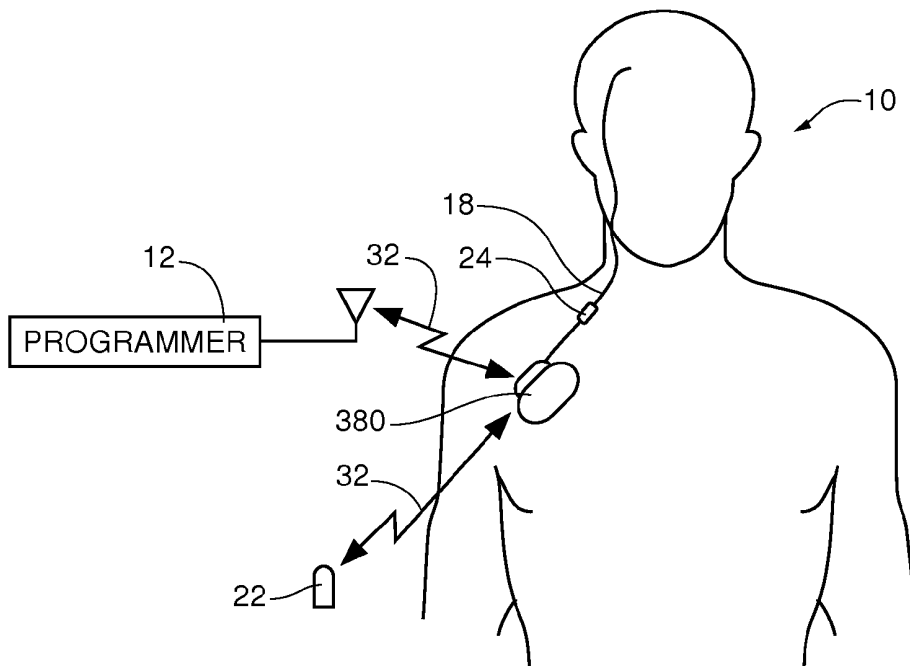
**Fig. 13**



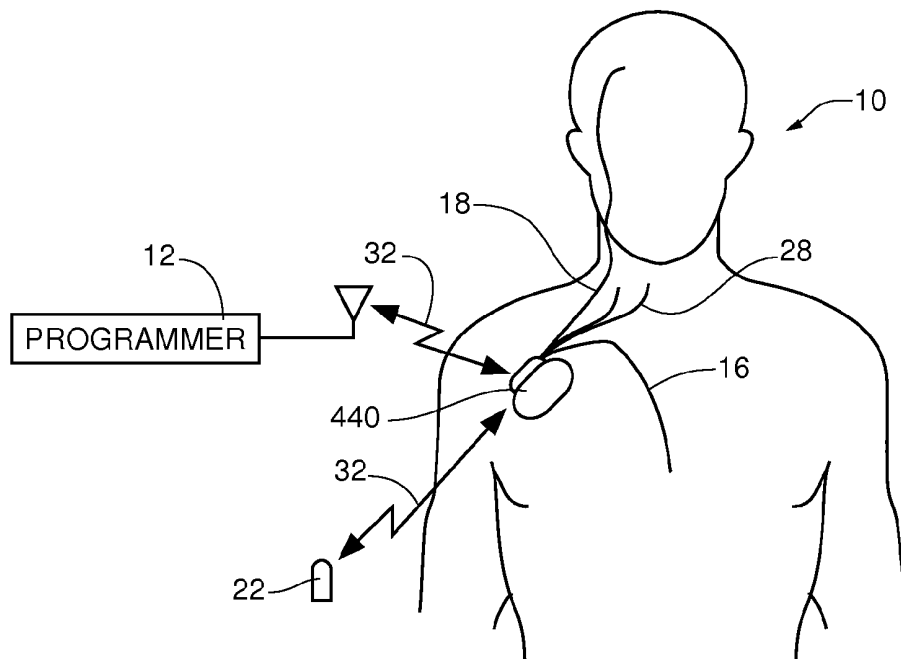
**Fig. 14**



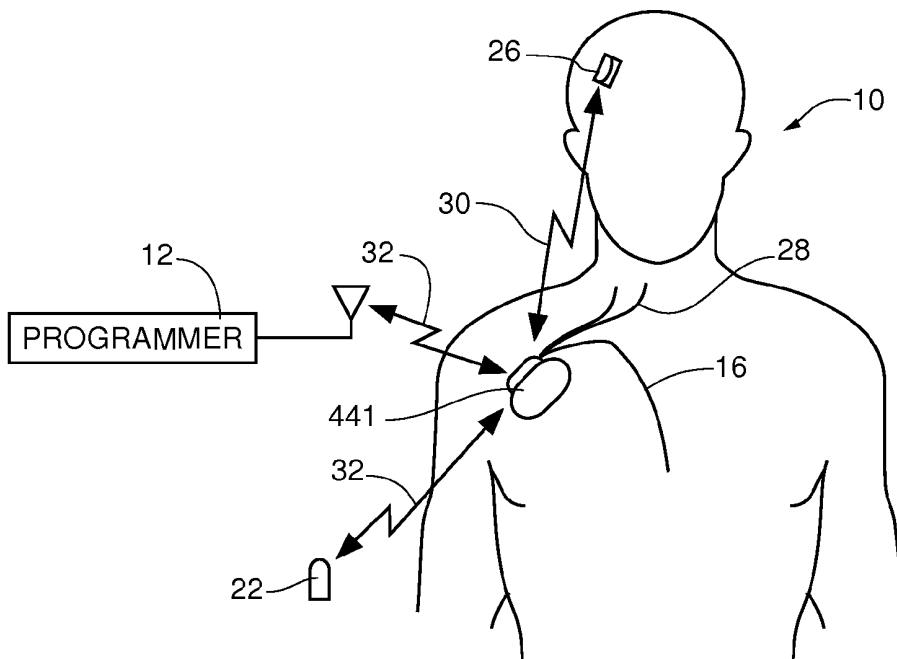
**Fig. 15**



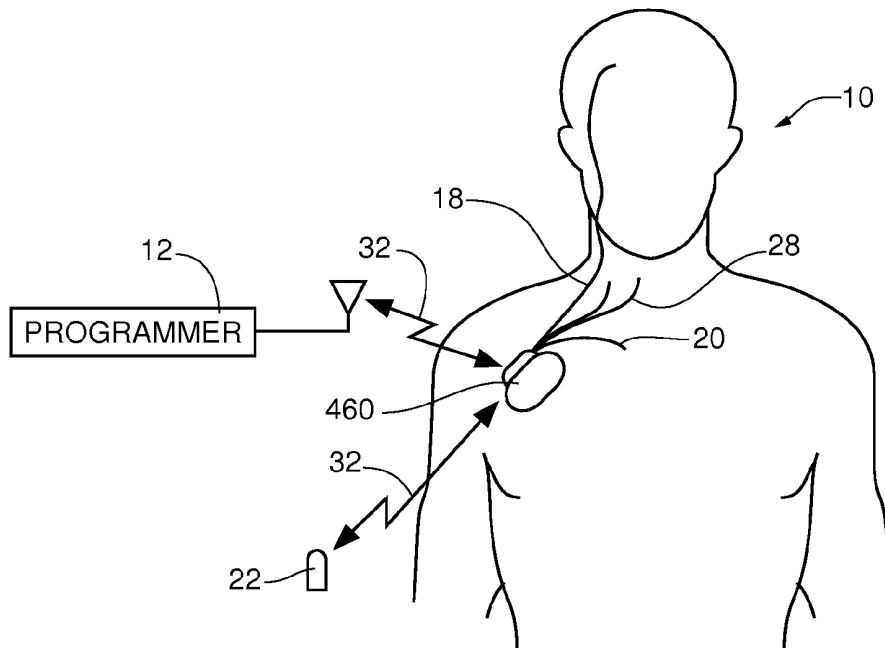
**Fig. 16A**



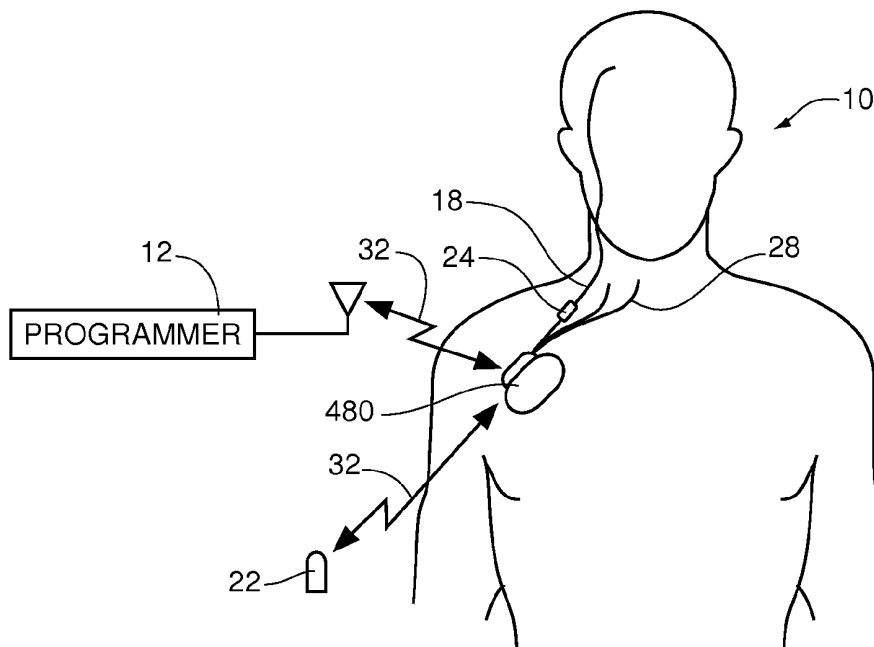
**Fig. 16B**



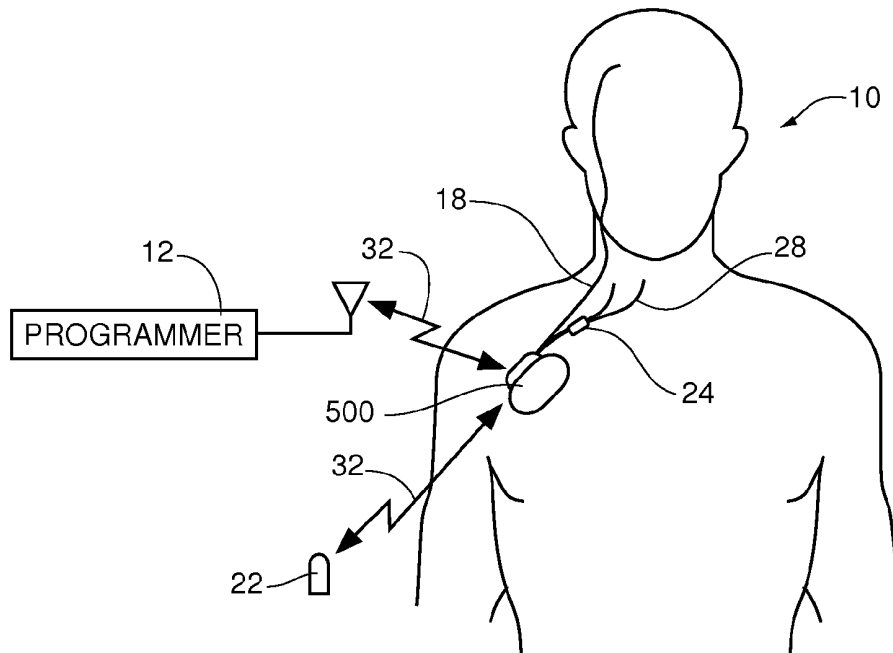
**Fig. 17**



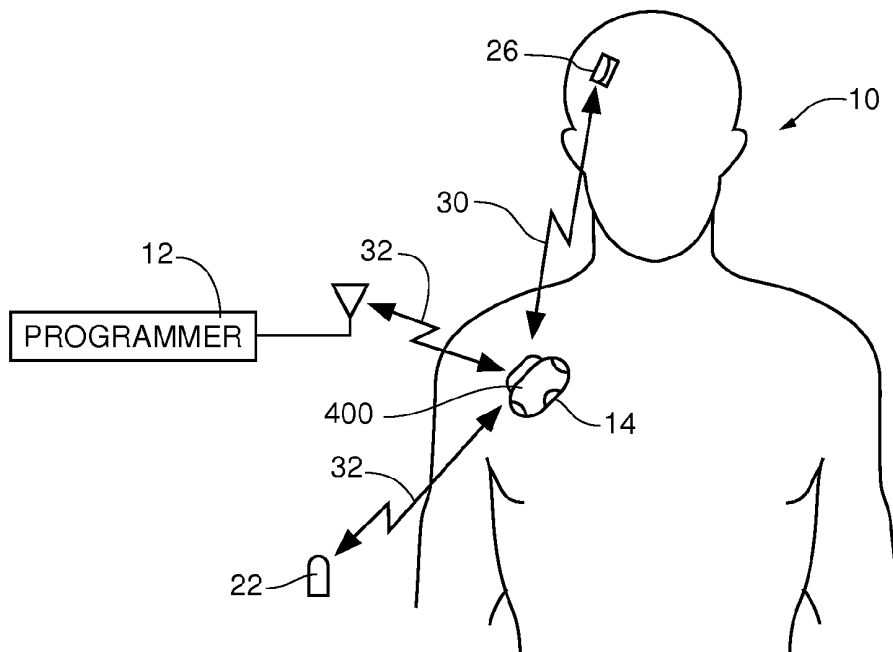
**Fig. 18**



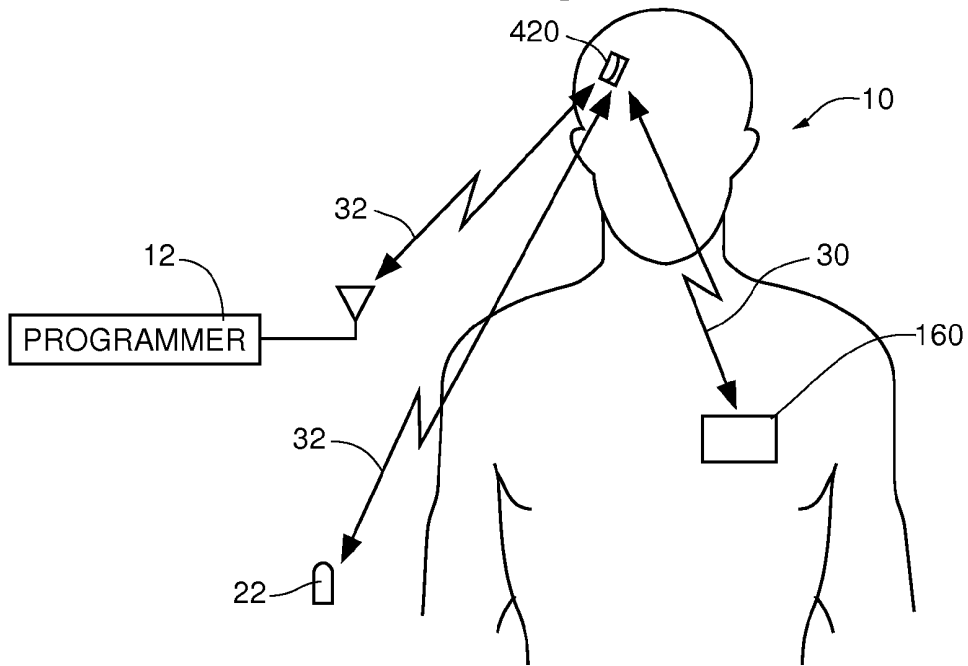
**Fig. 19**



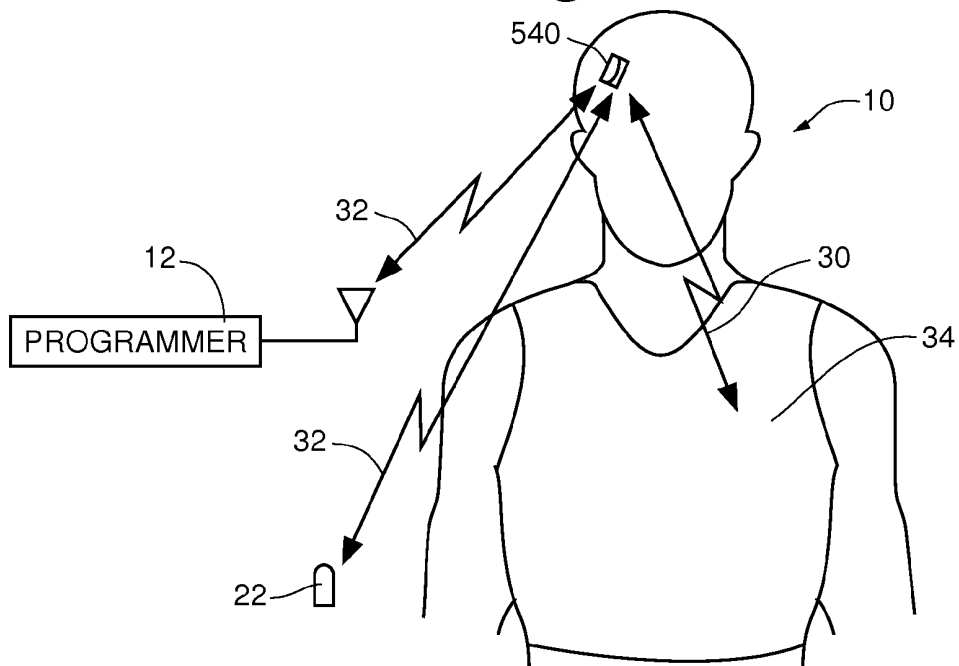
**Fig. 20**



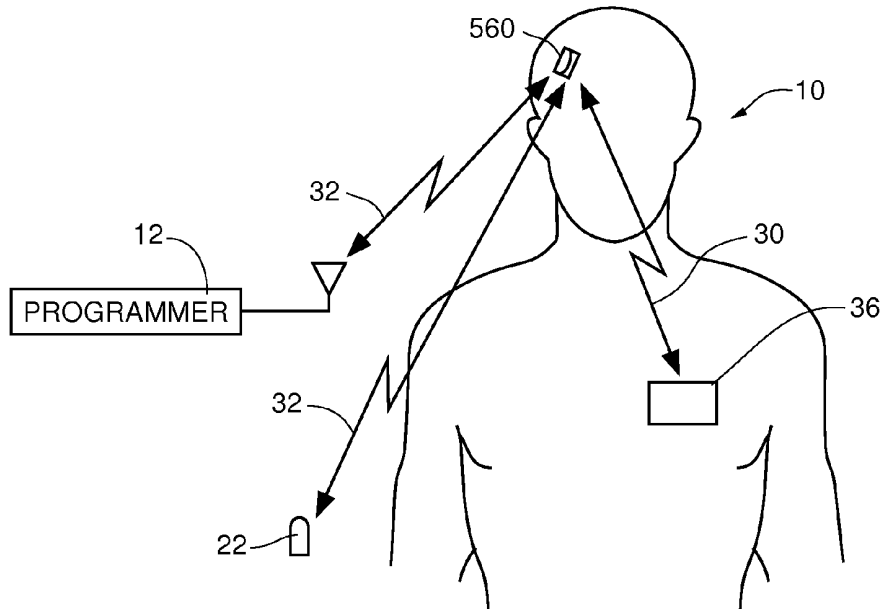
**Fig. 21**



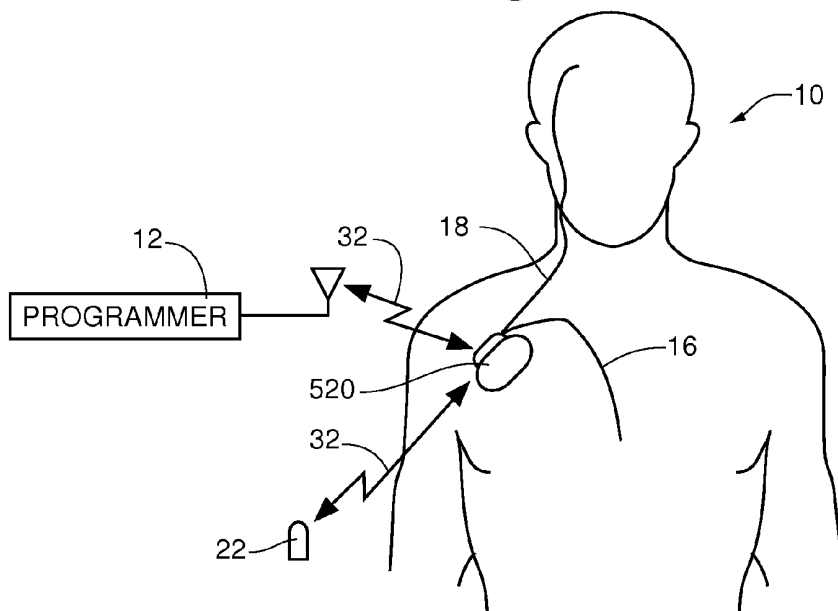
**Fig. 22**



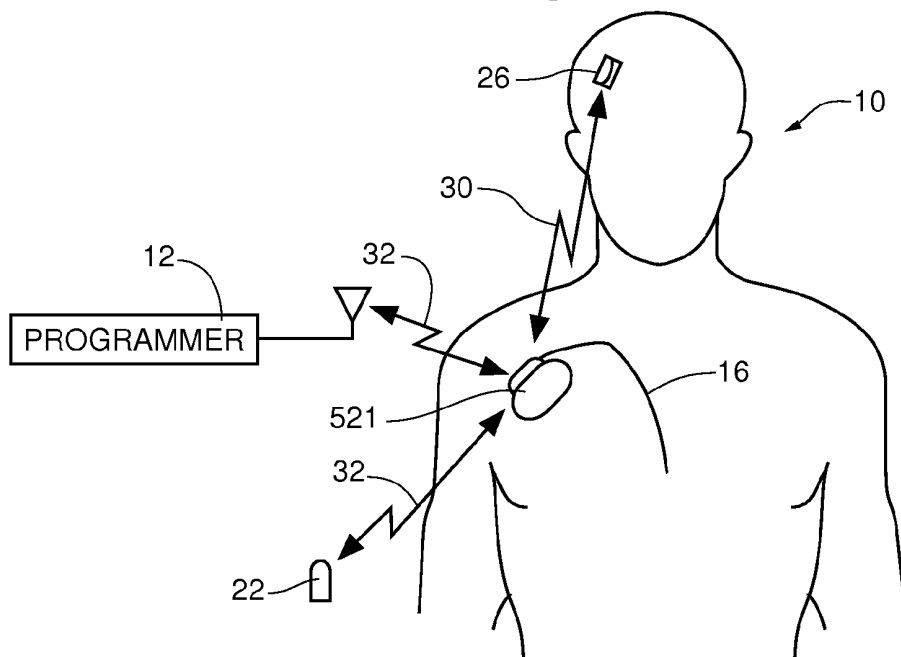
**Fig. 23**



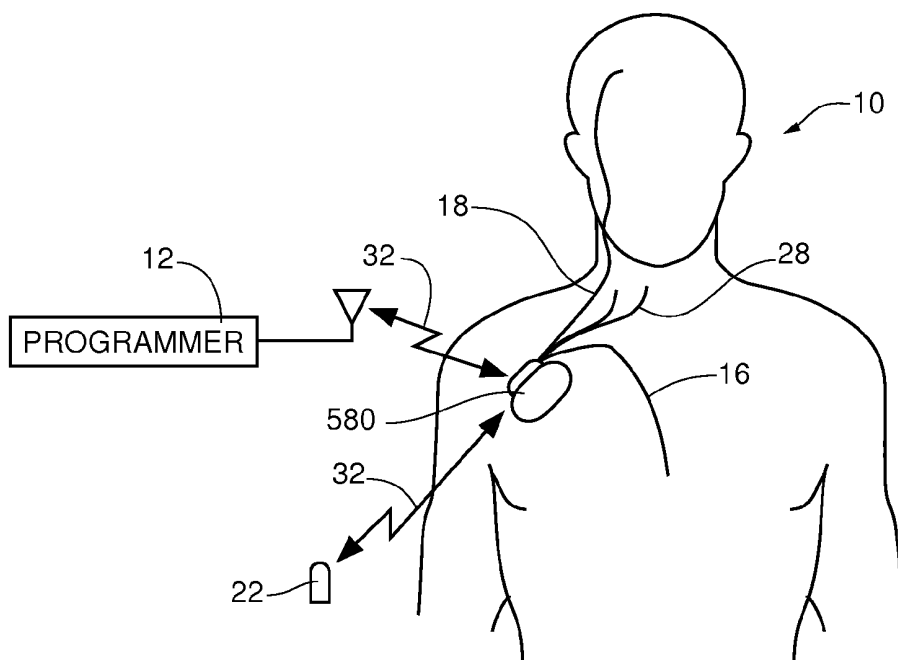
**Fig. 24A**



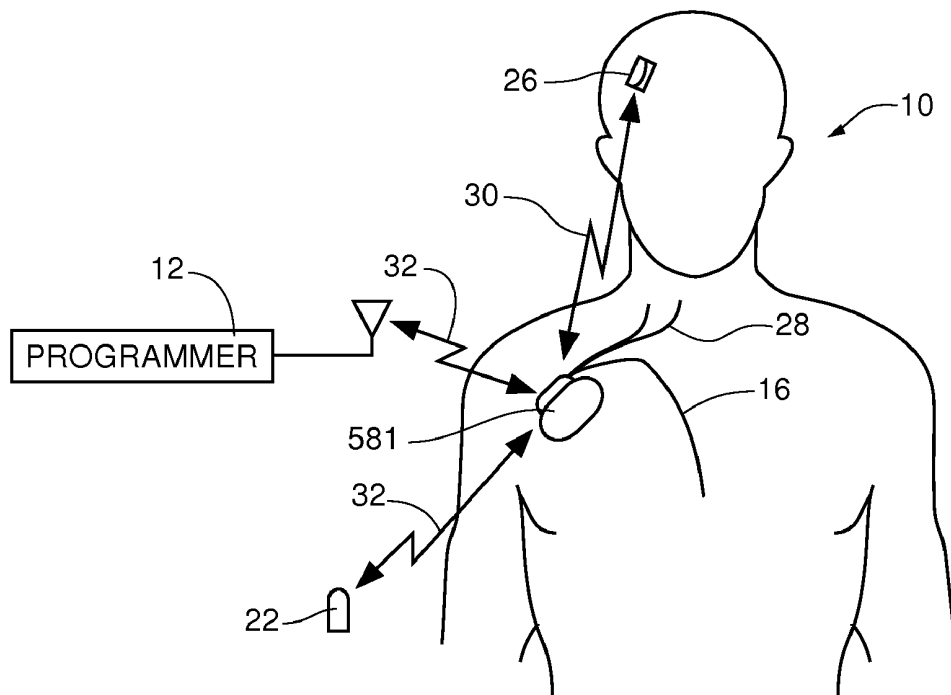
**Fig. 24B**



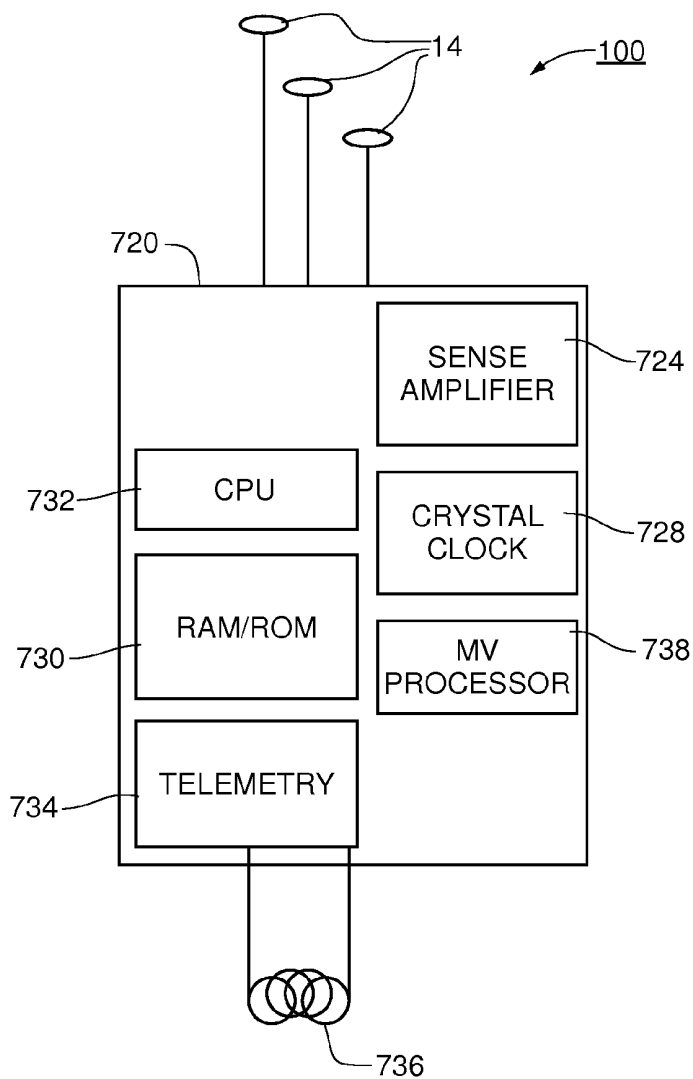
**Fig. 25A**



**Fig. 25B**



**Fig. 26**



**Fig. 27**

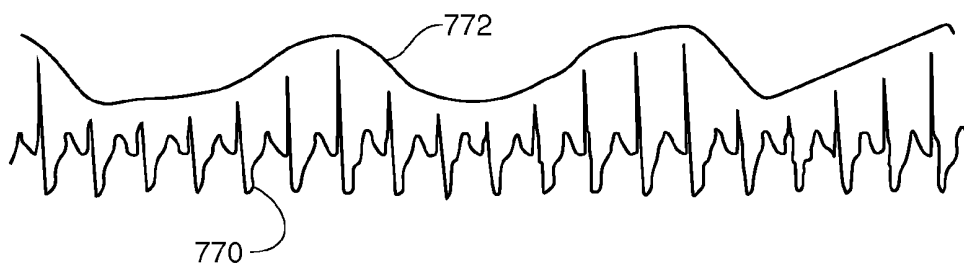
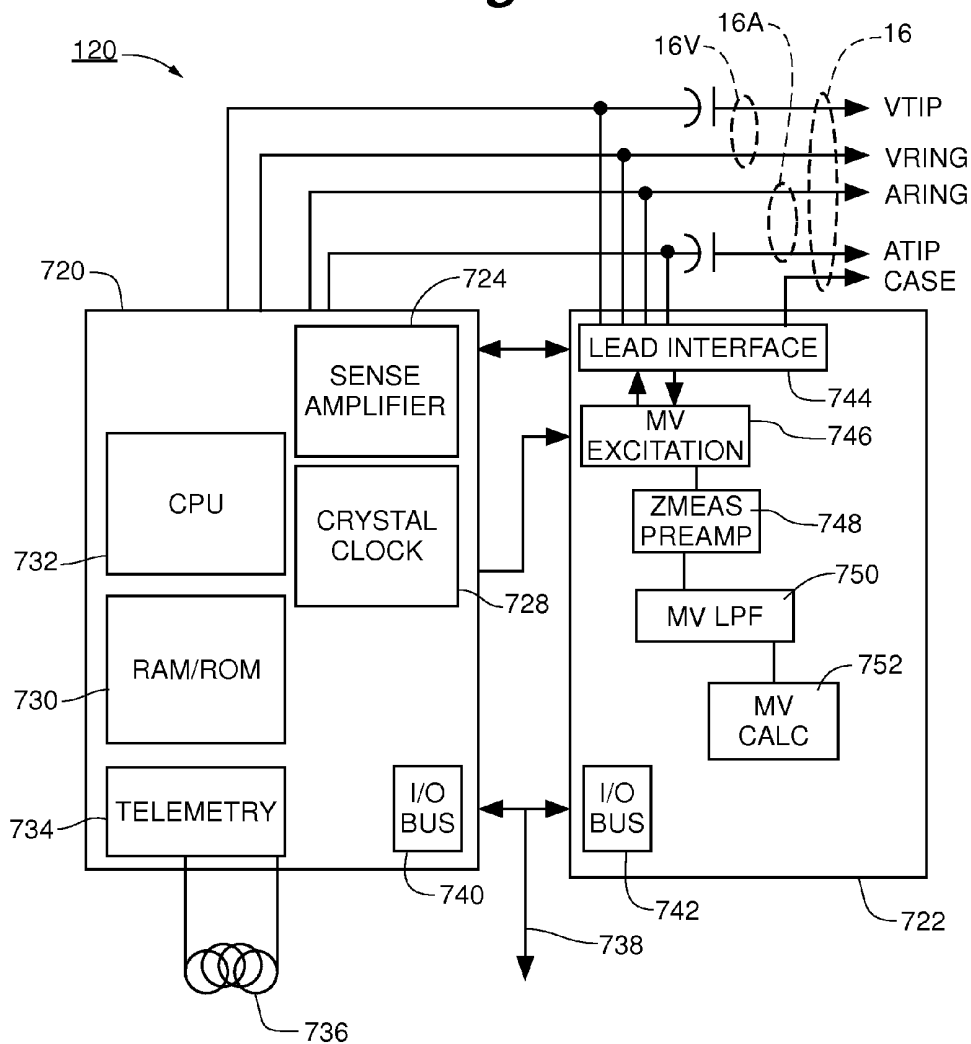
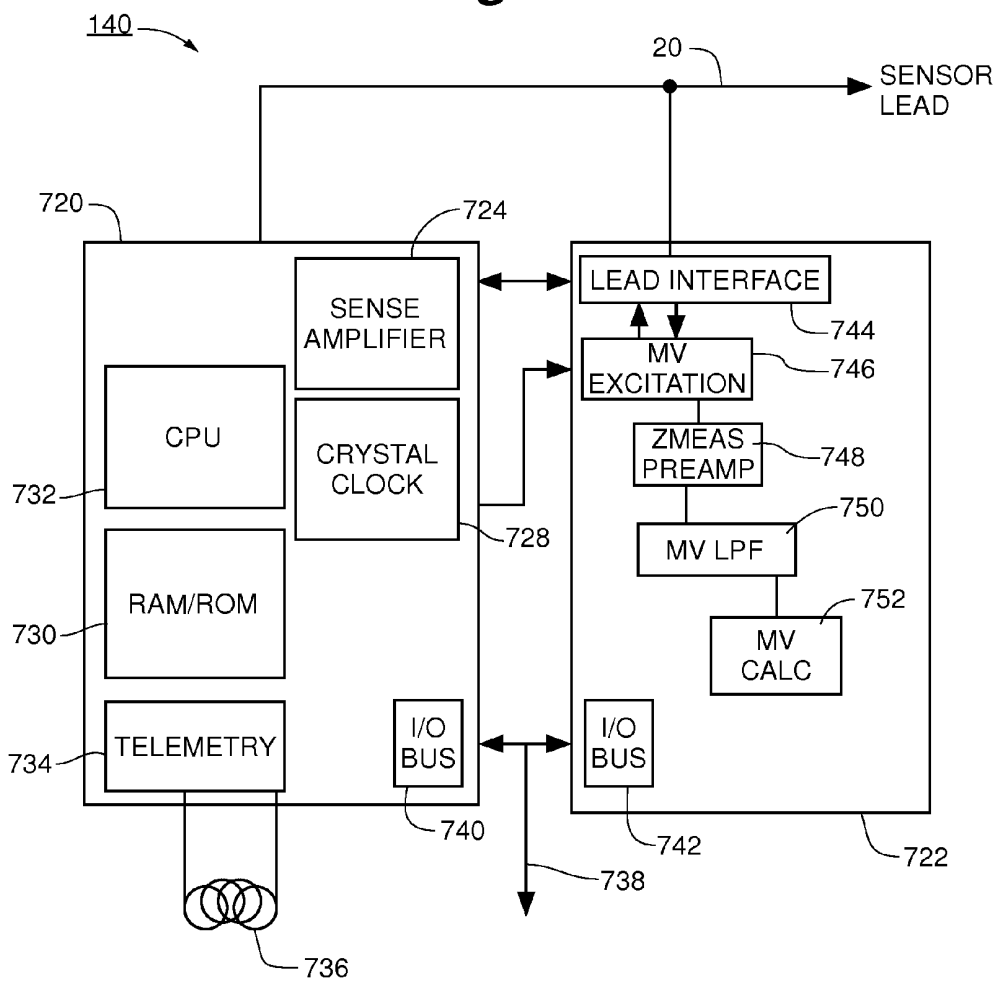


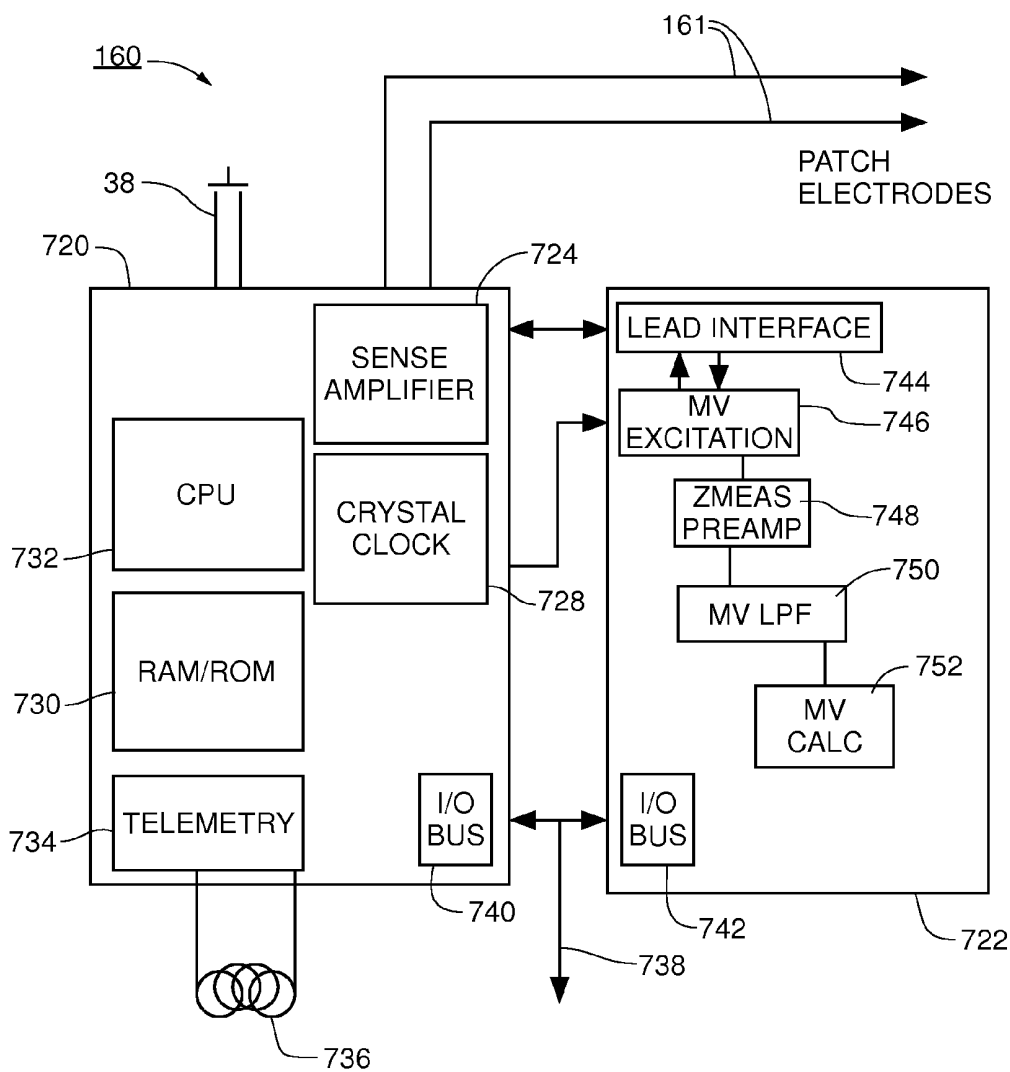
Fig. 28



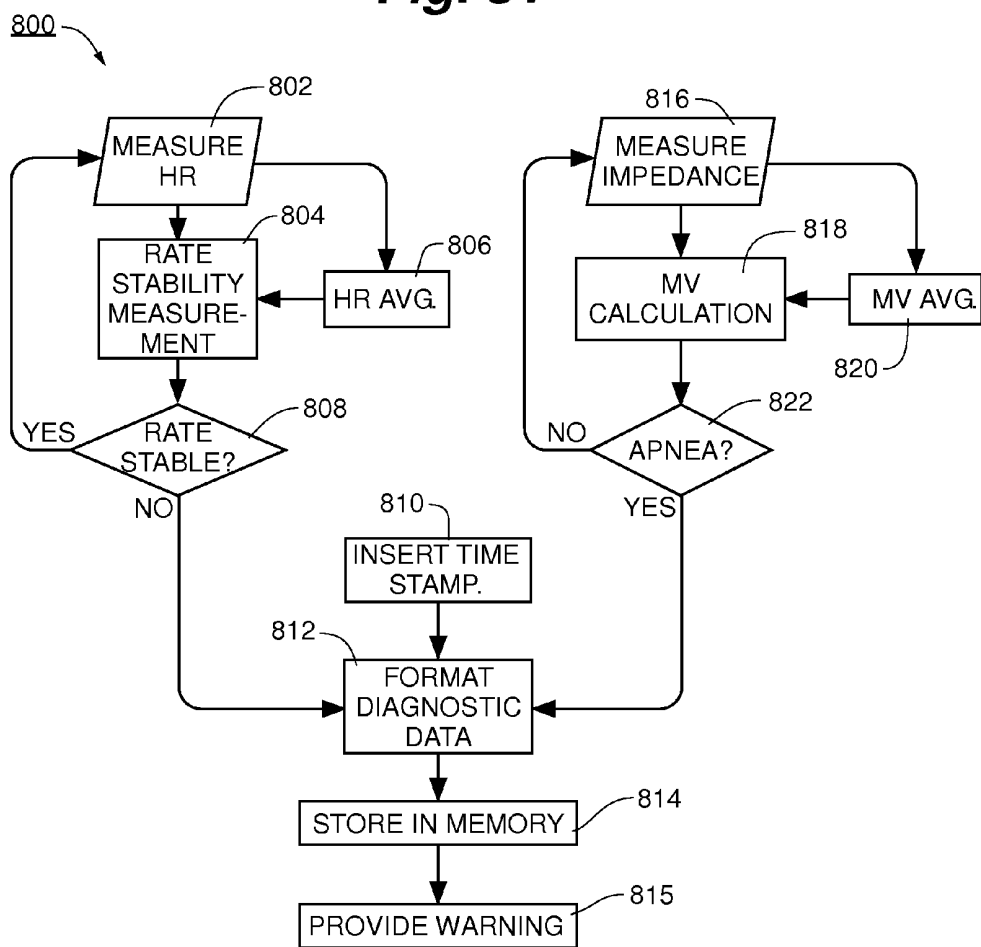
**Fig. 29**



**Fig. 30**



**Fig. 31**



**Fig. 32**

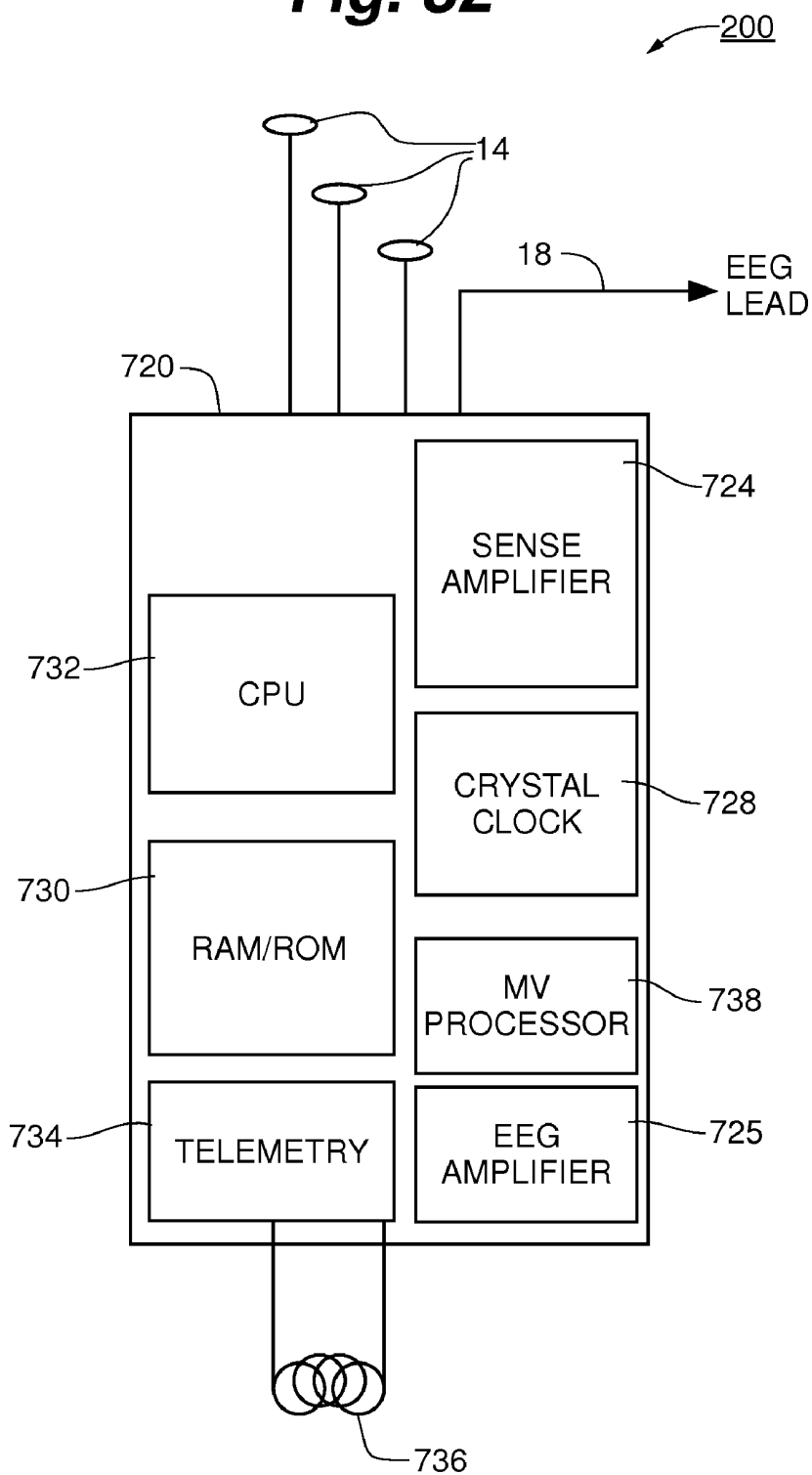


Fig. 33

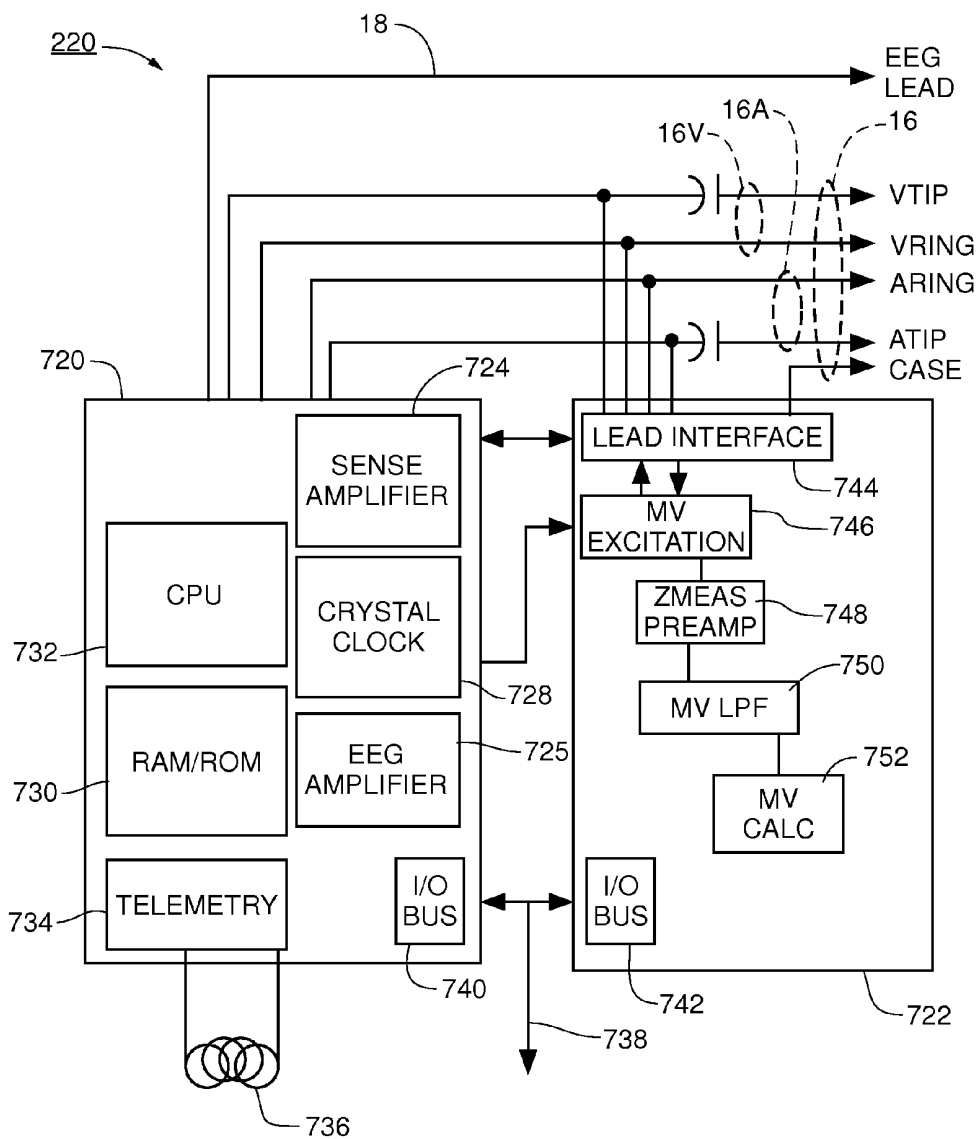


Fig. 34

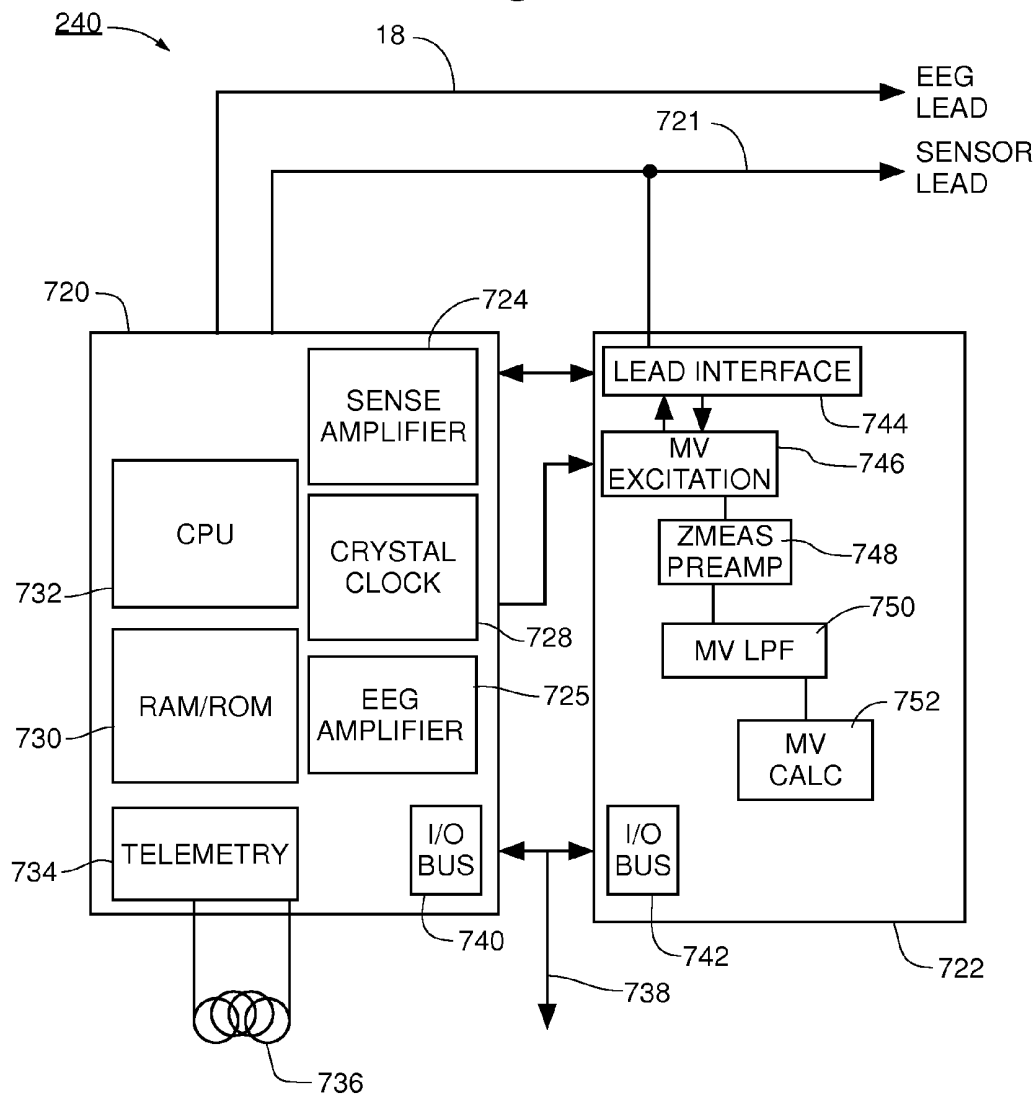
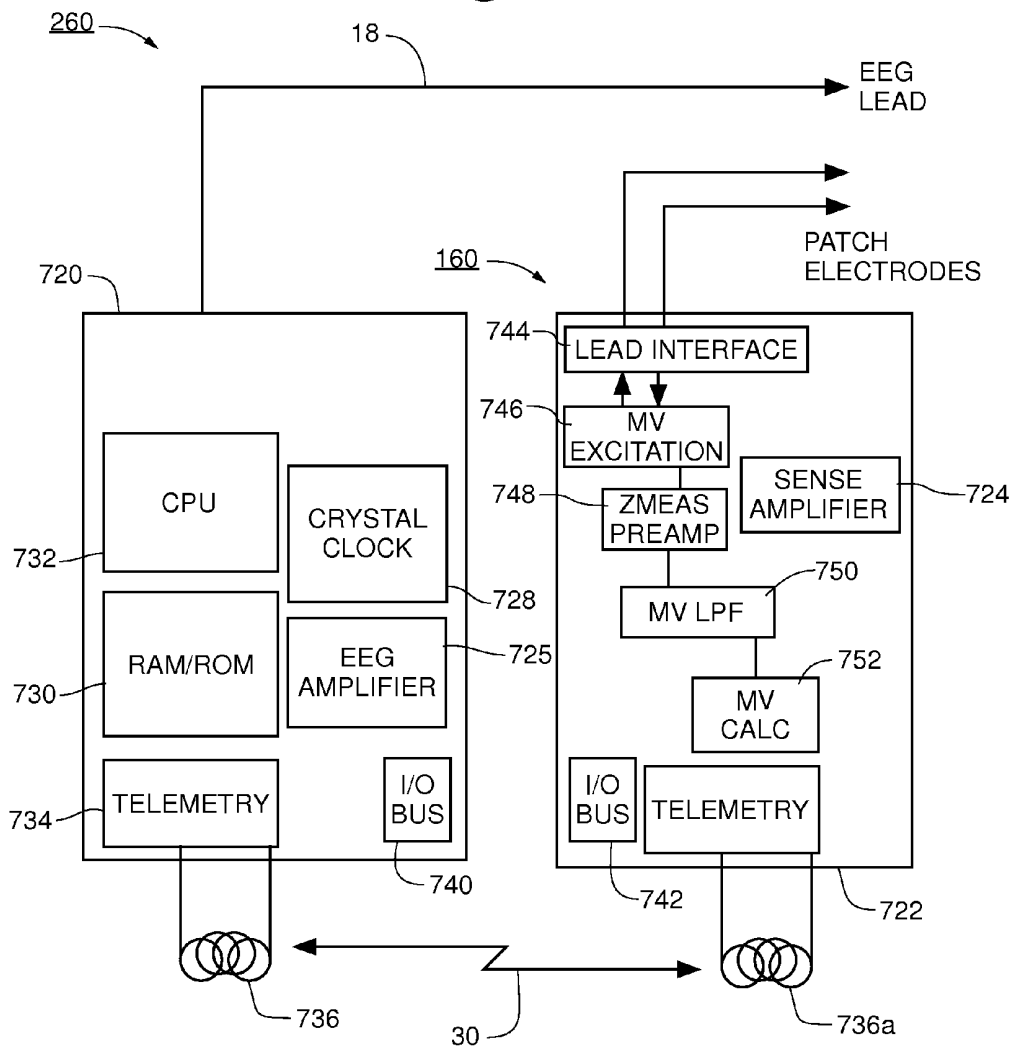
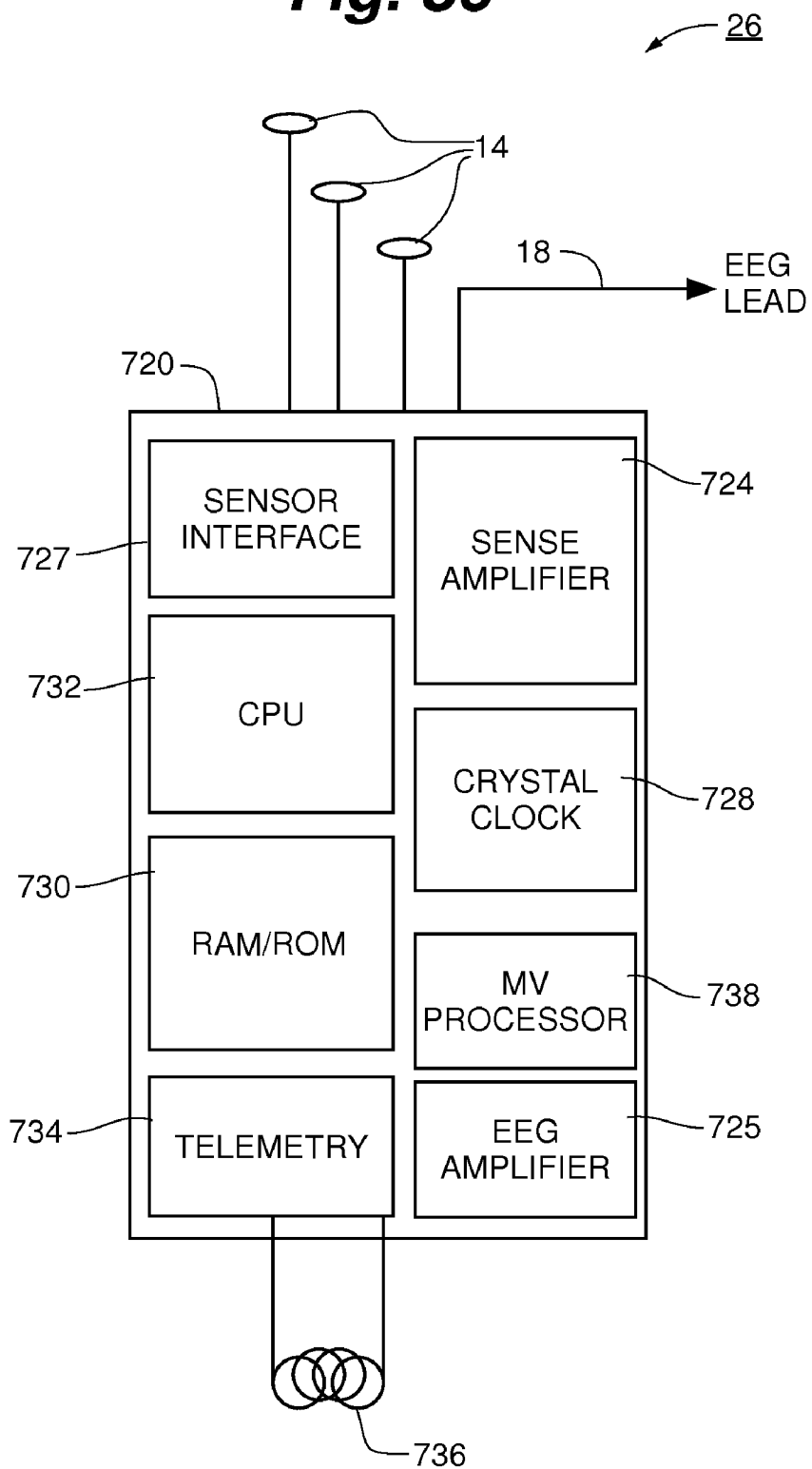


Fig. 35



**Fig. 36**



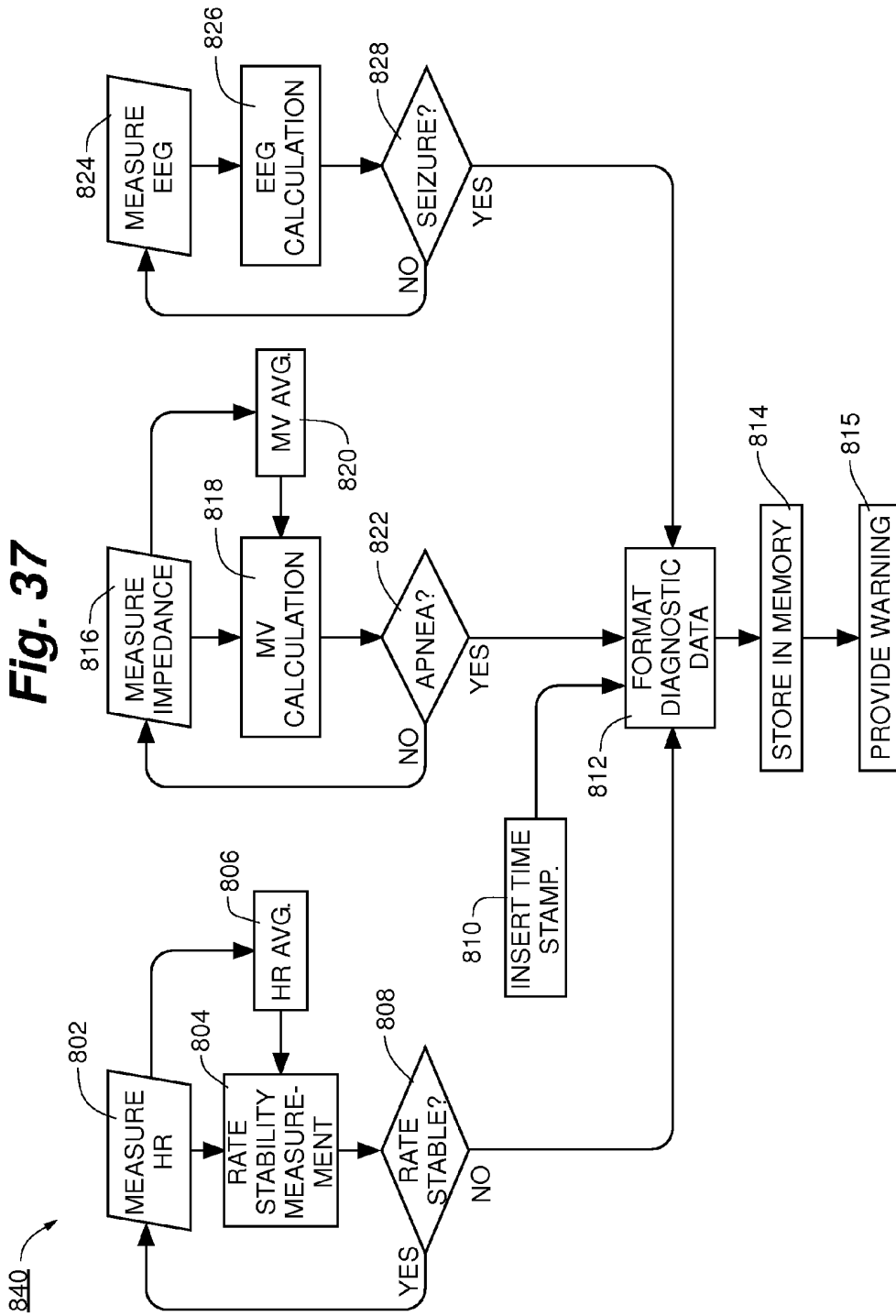


Fig. 38

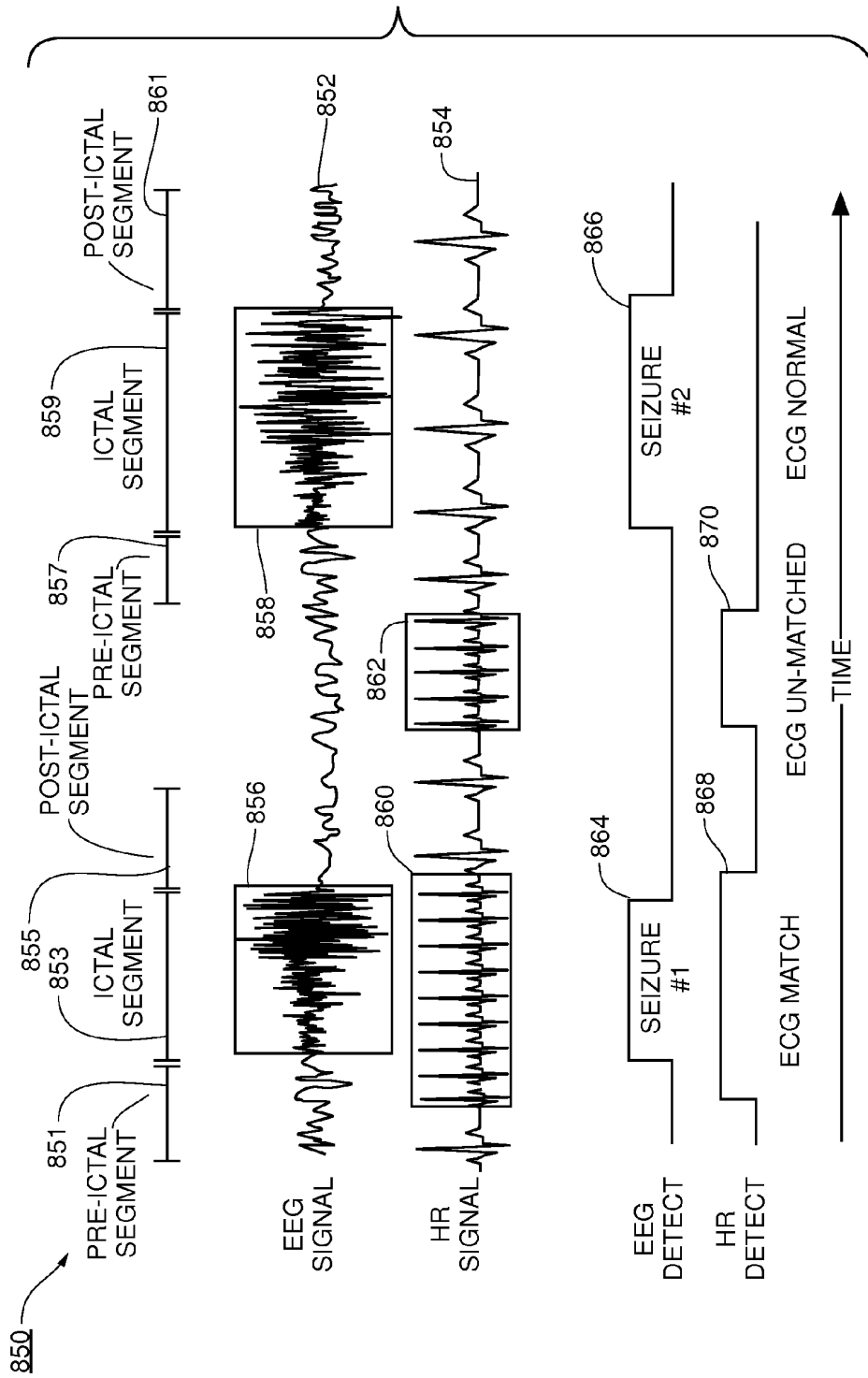
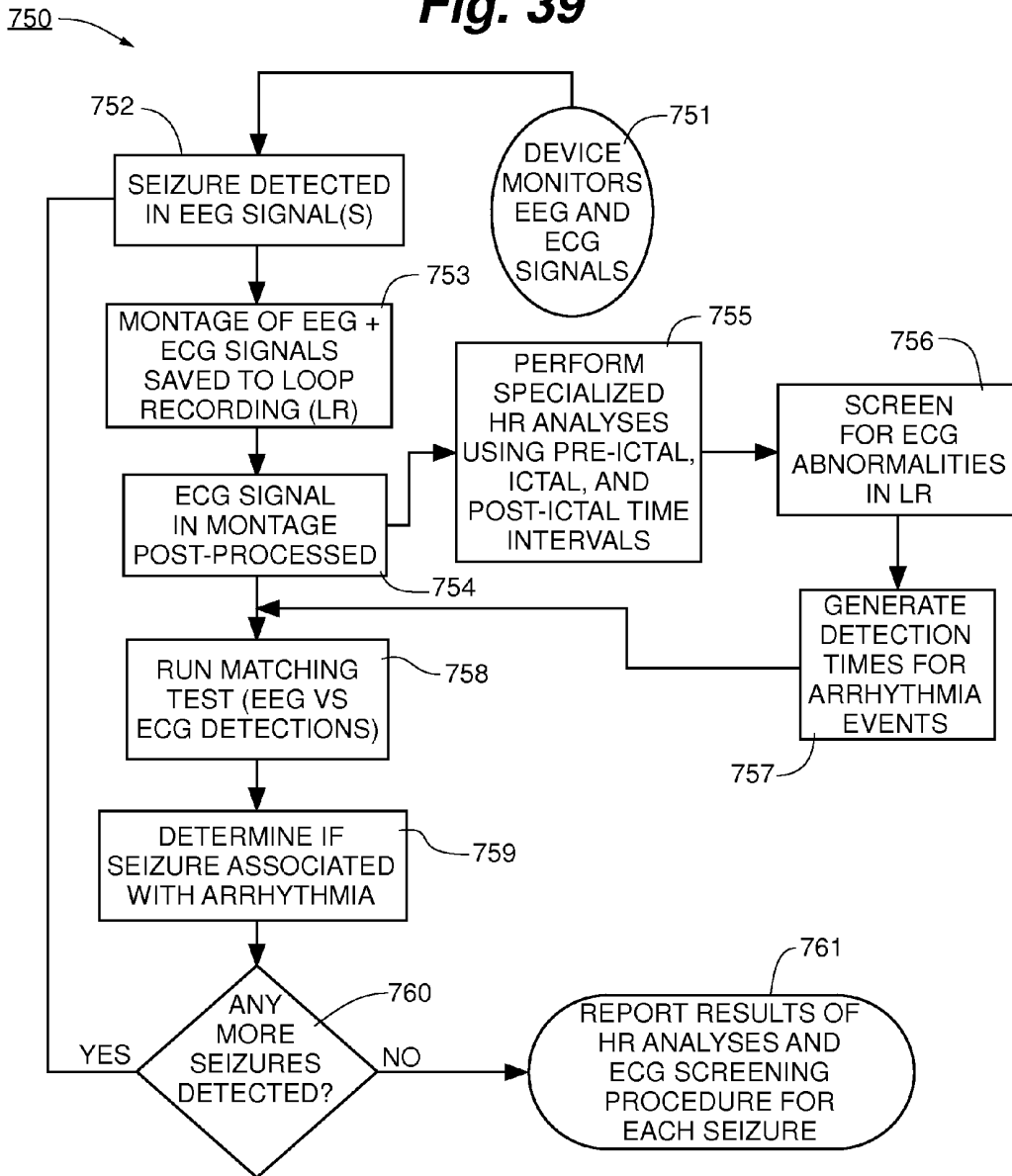


Fig. 39



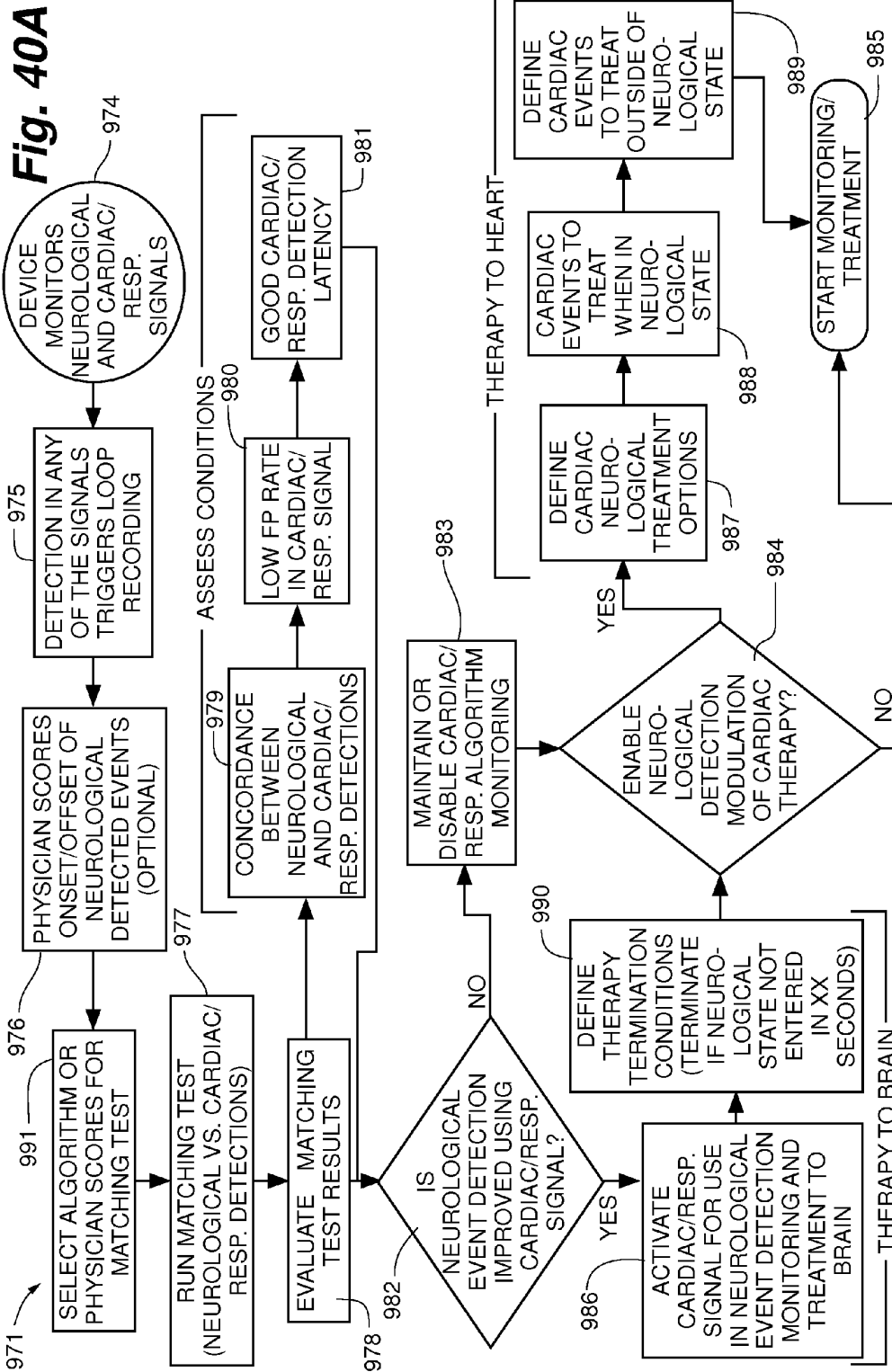
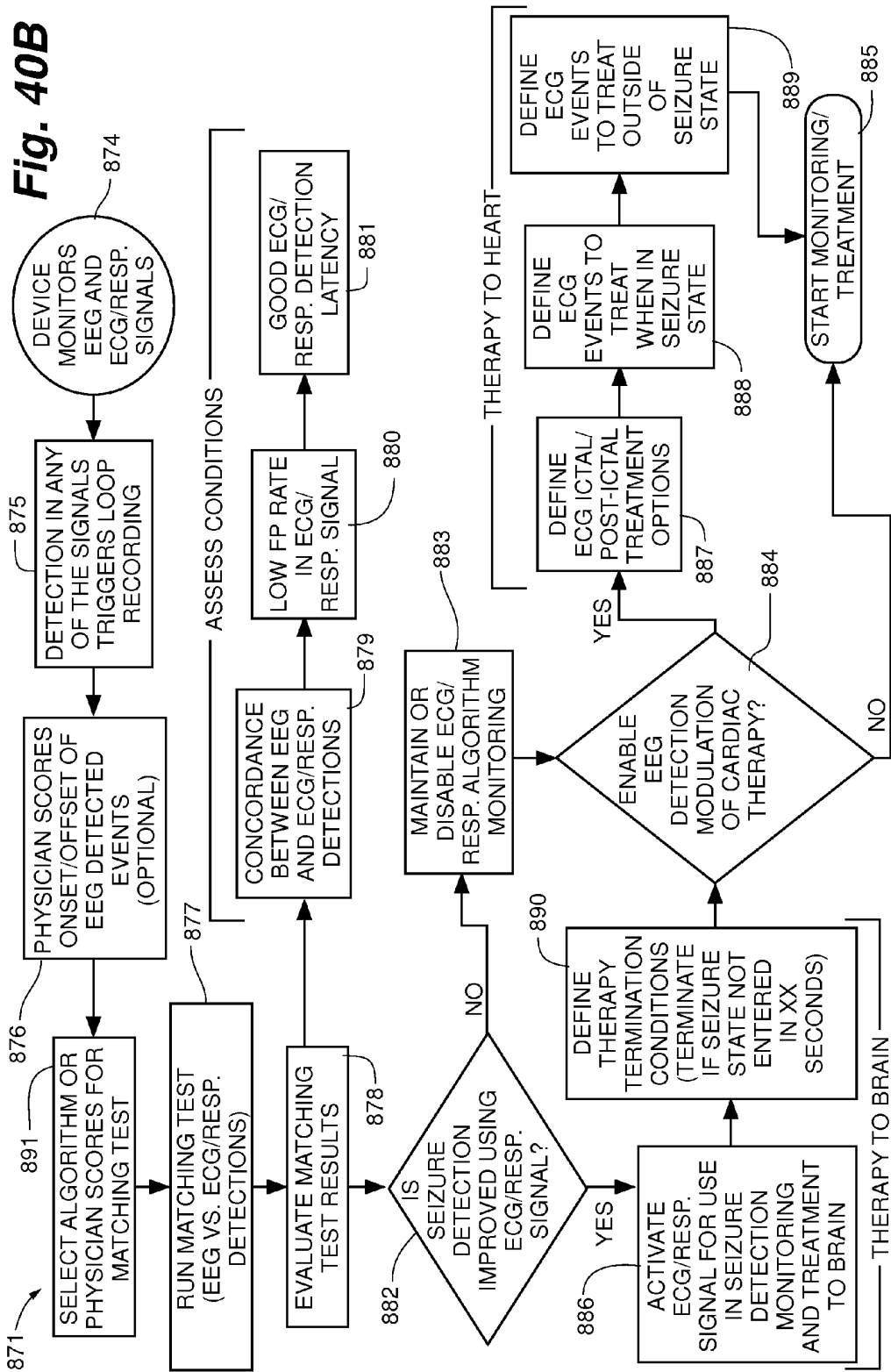
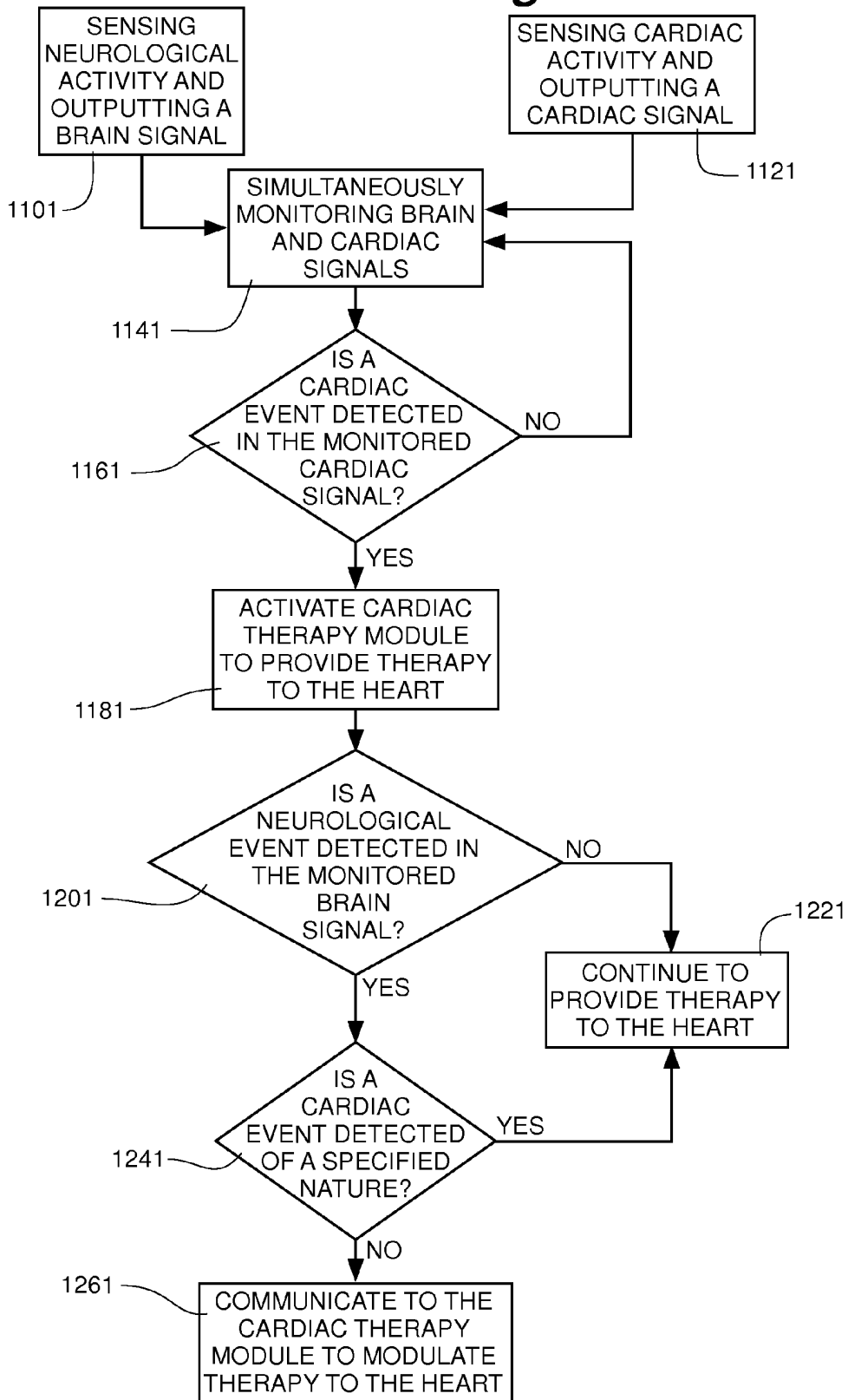


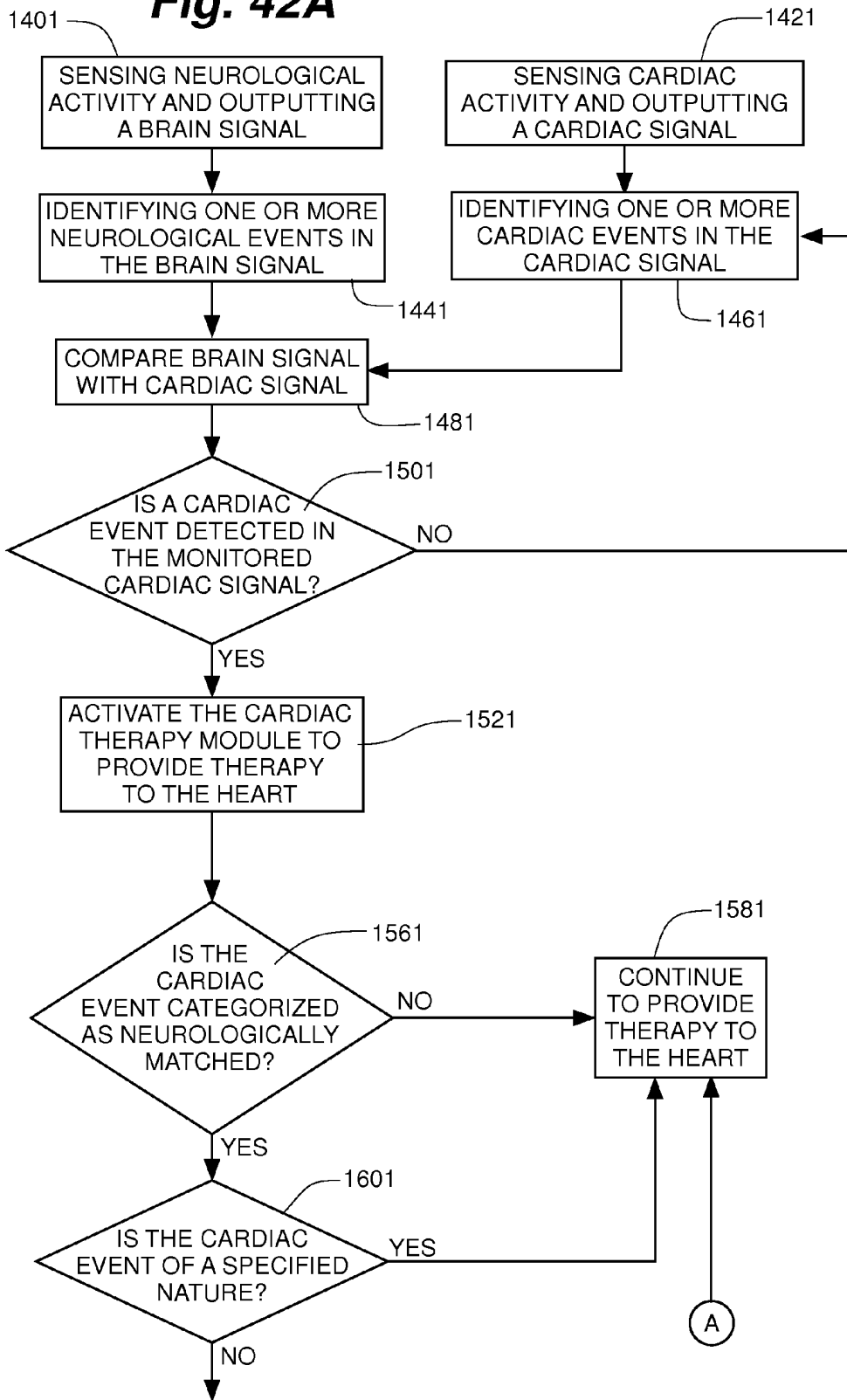
Fig. 40B

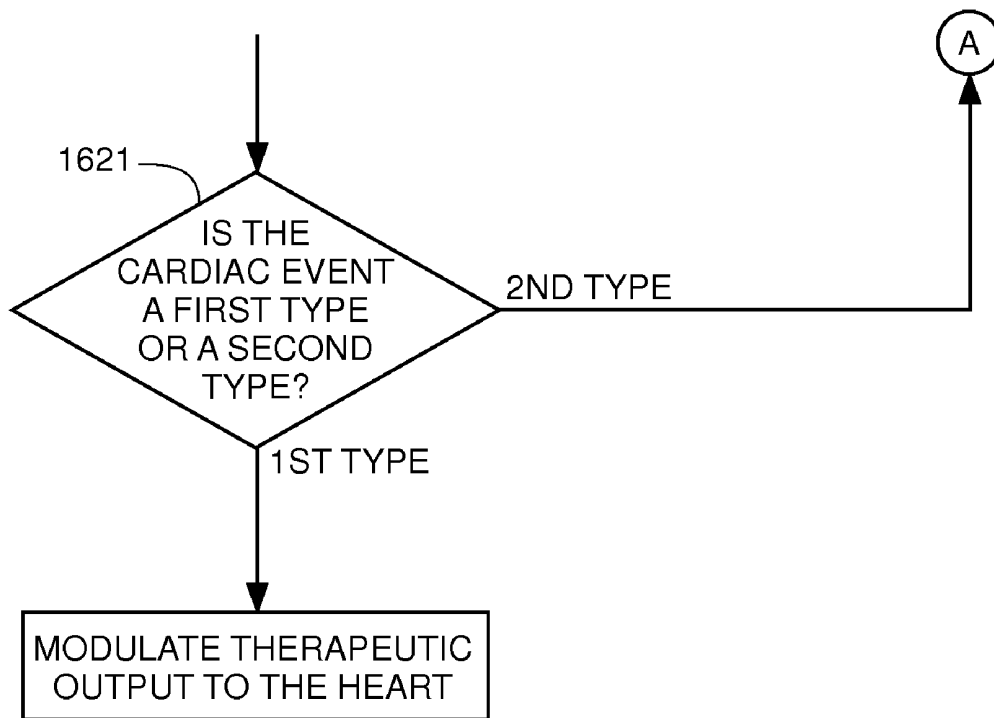


**Fig. 41**



**Fig. 42A**





**Fig. 42B**

**Fig. 43**

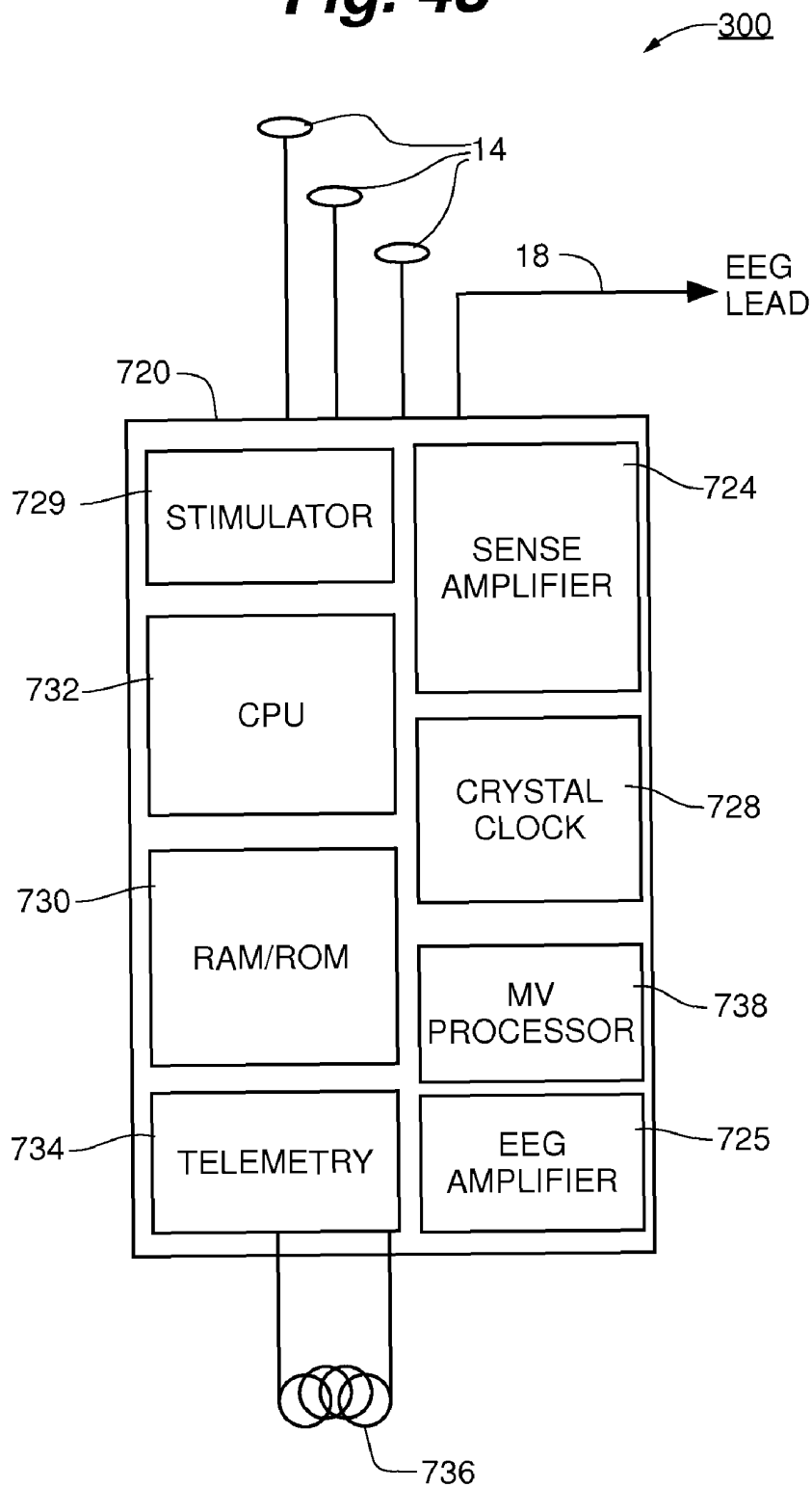
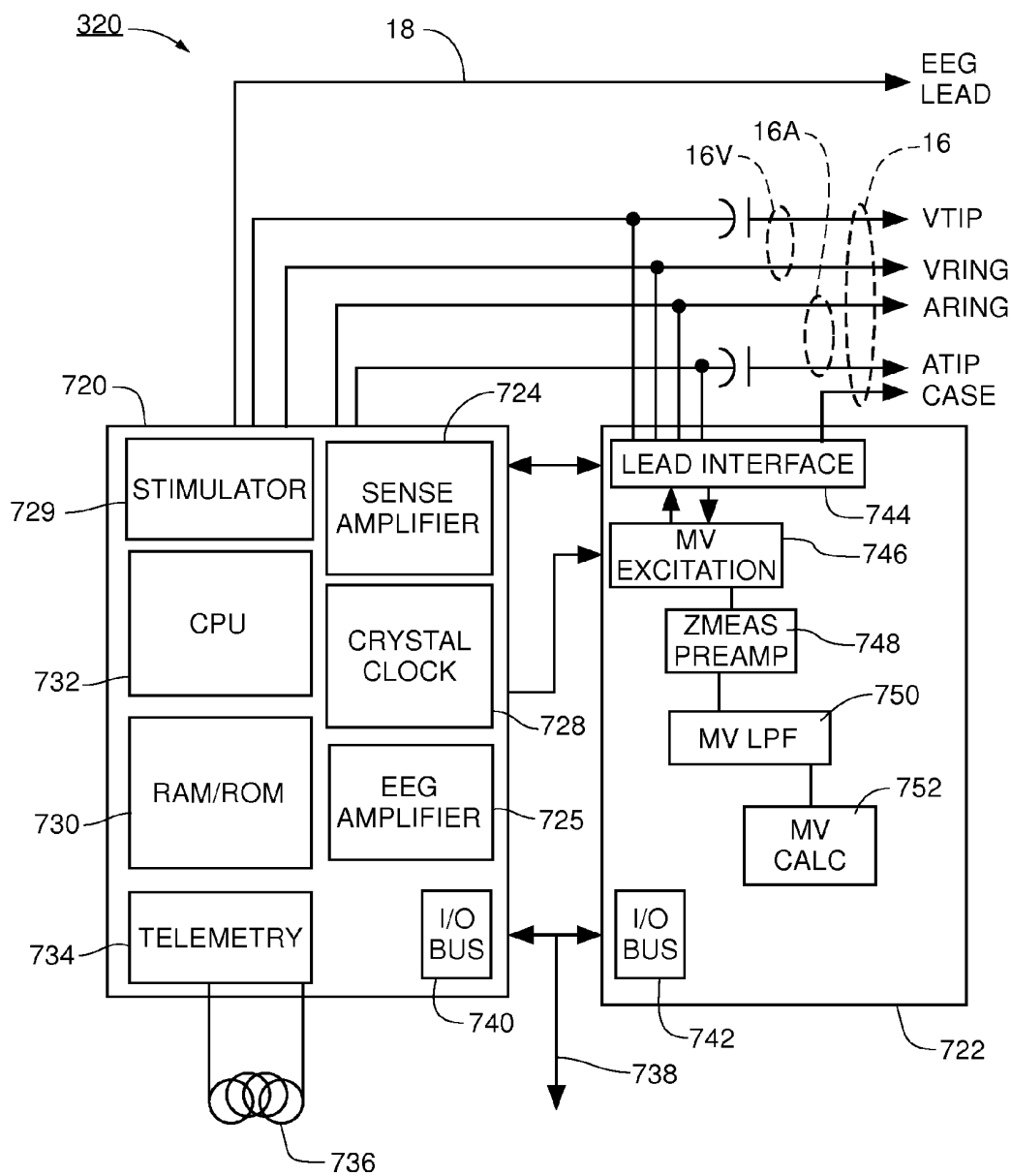


Fig. 44



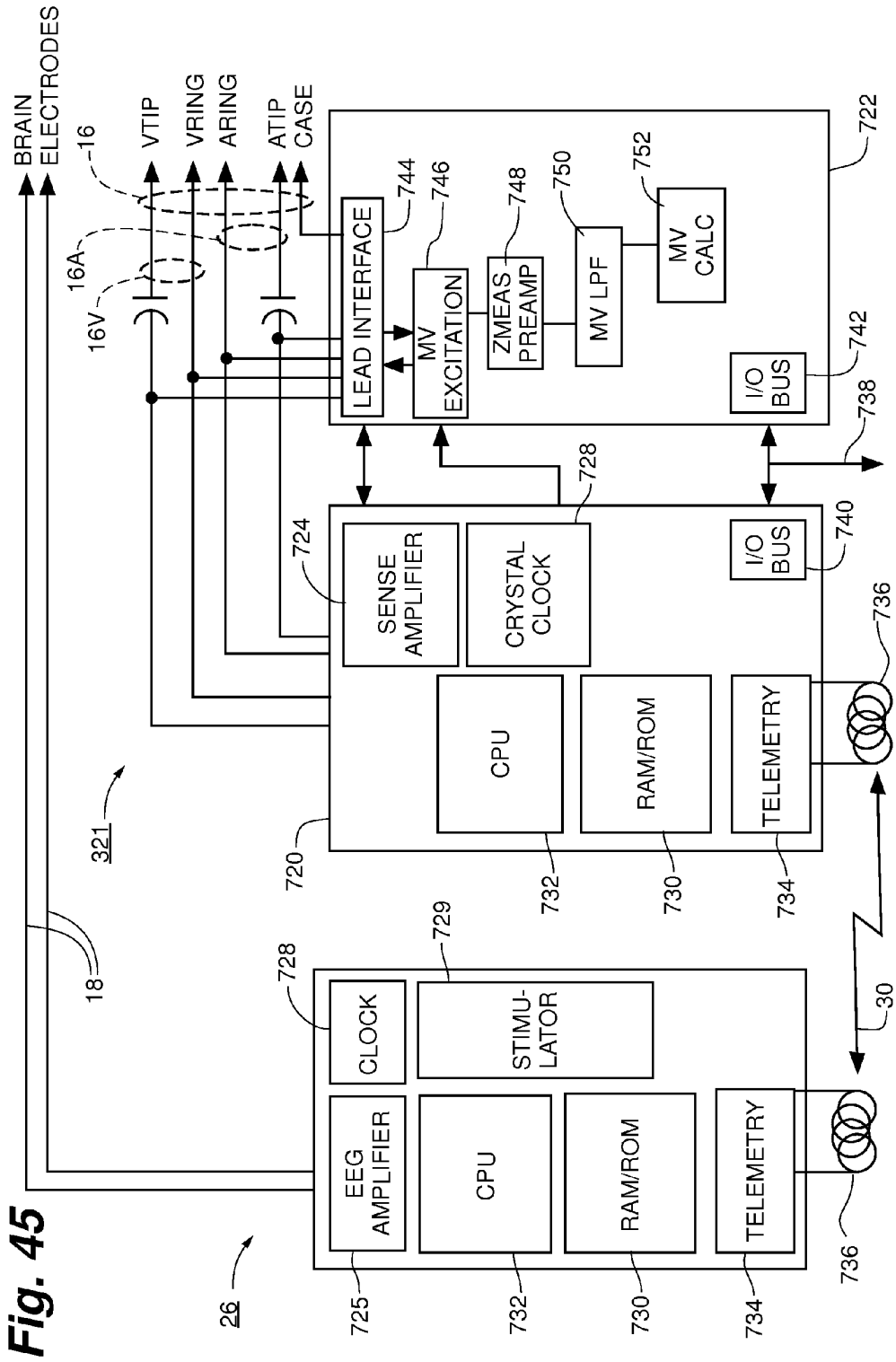


Fig. 46

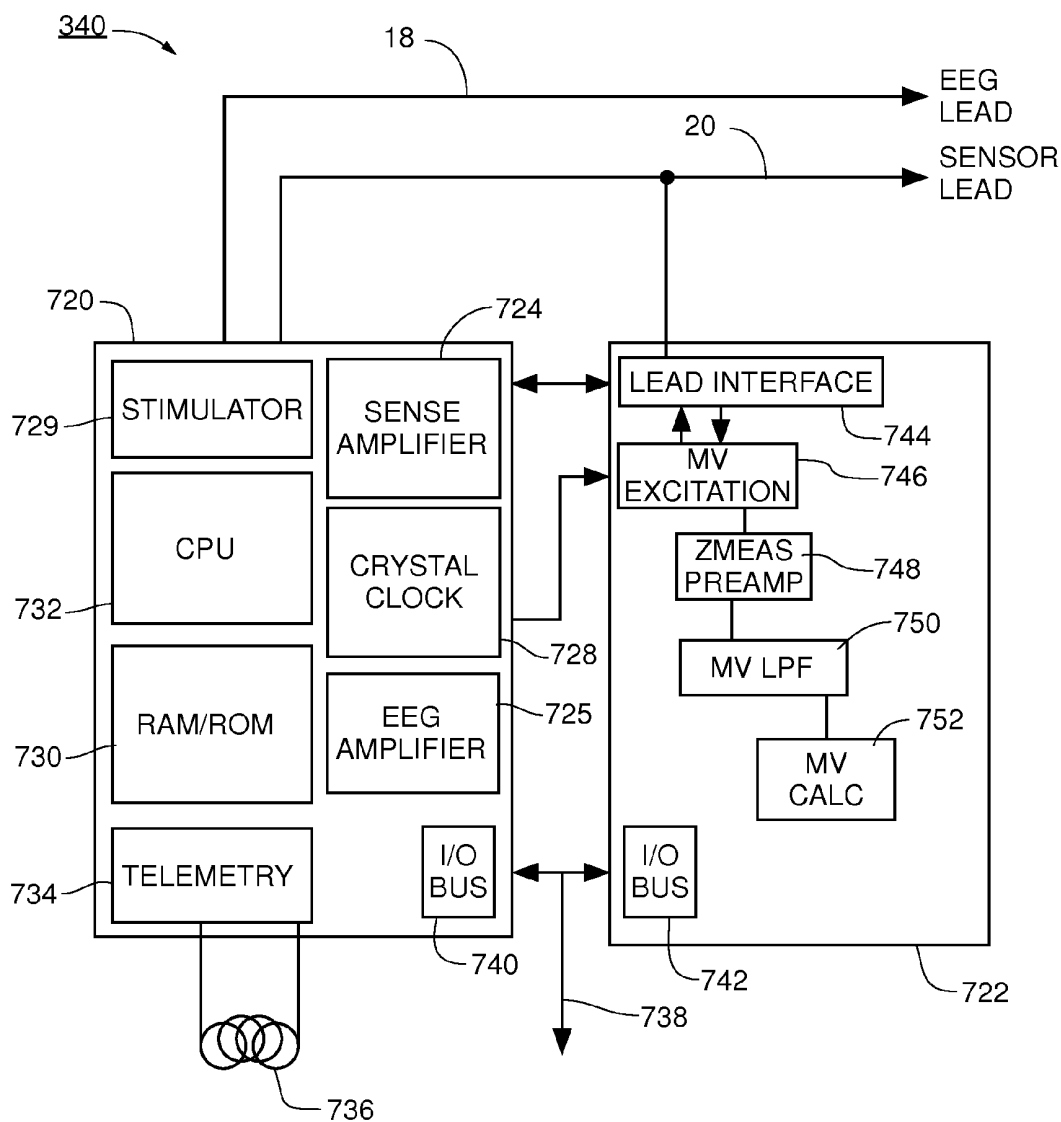


Fig. 47

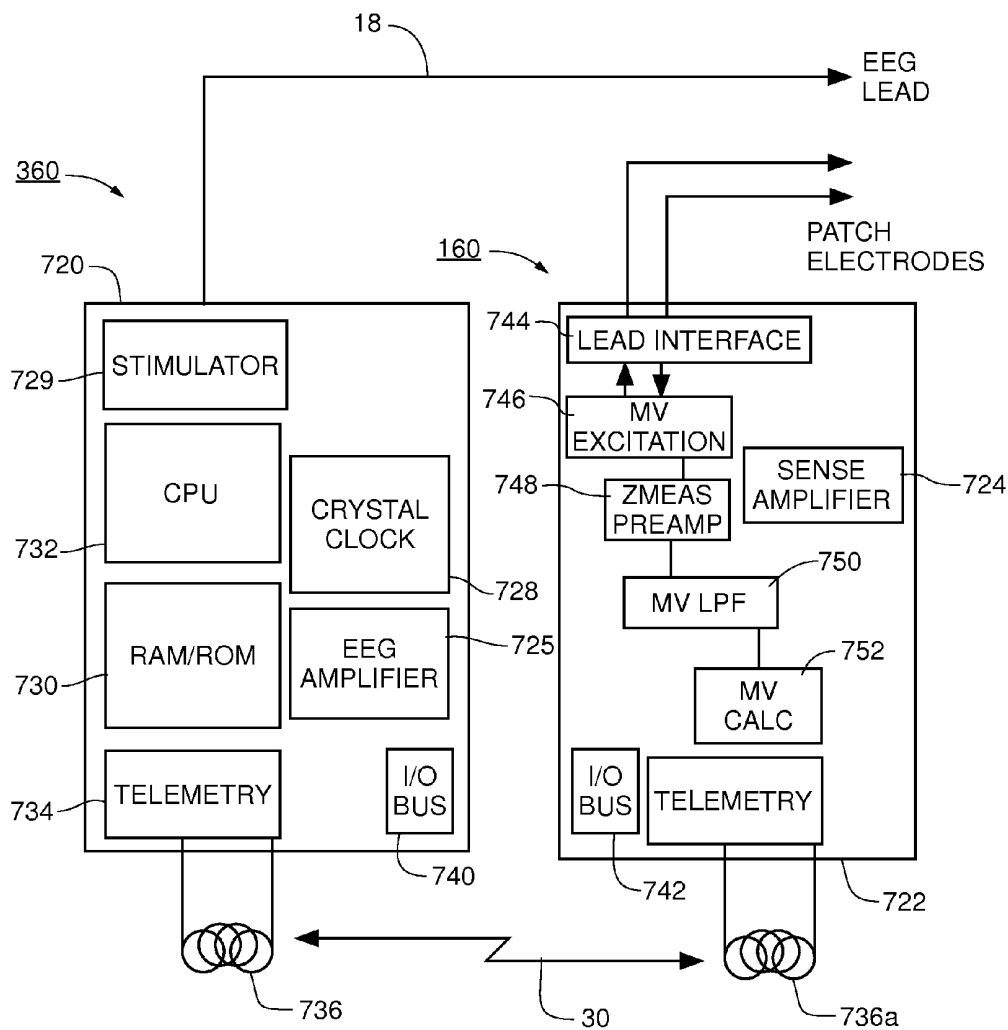


Fig. 48

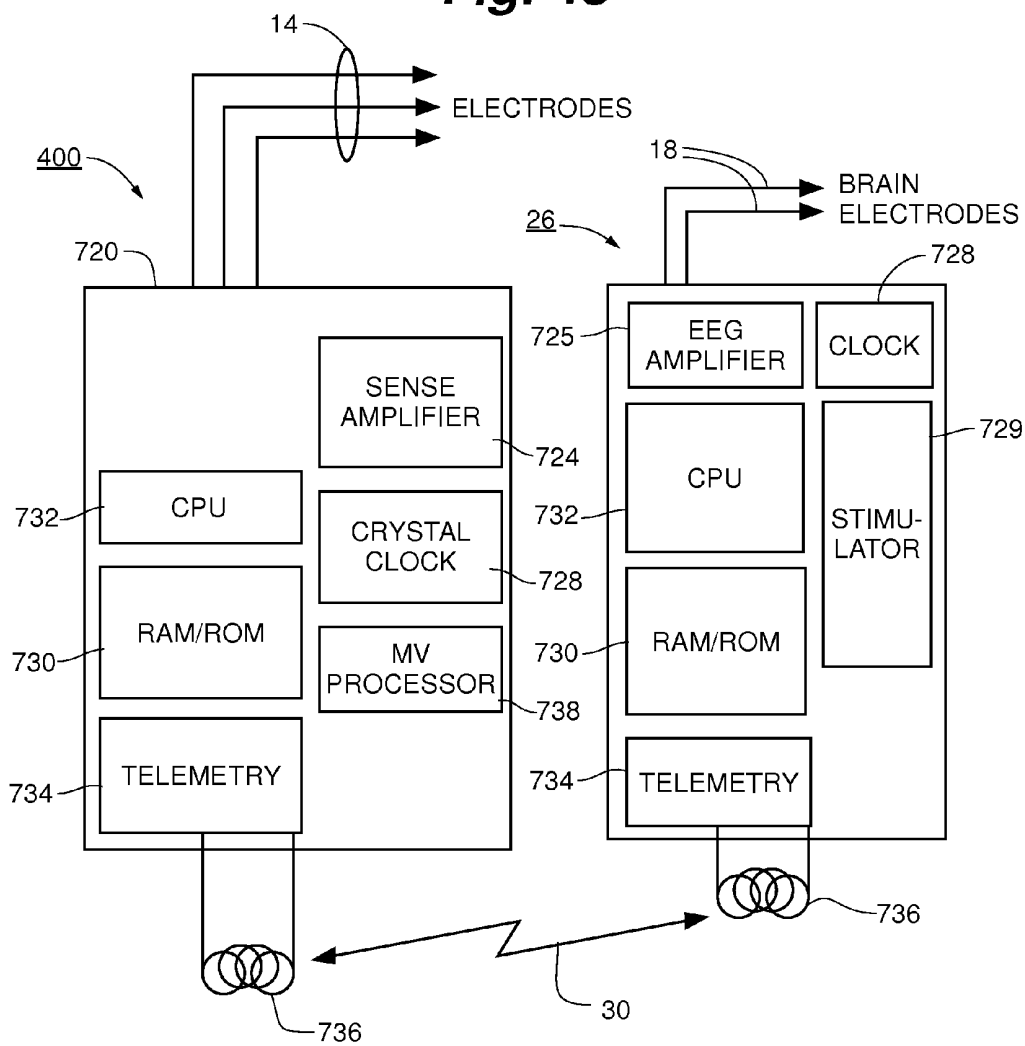


Fig. 49

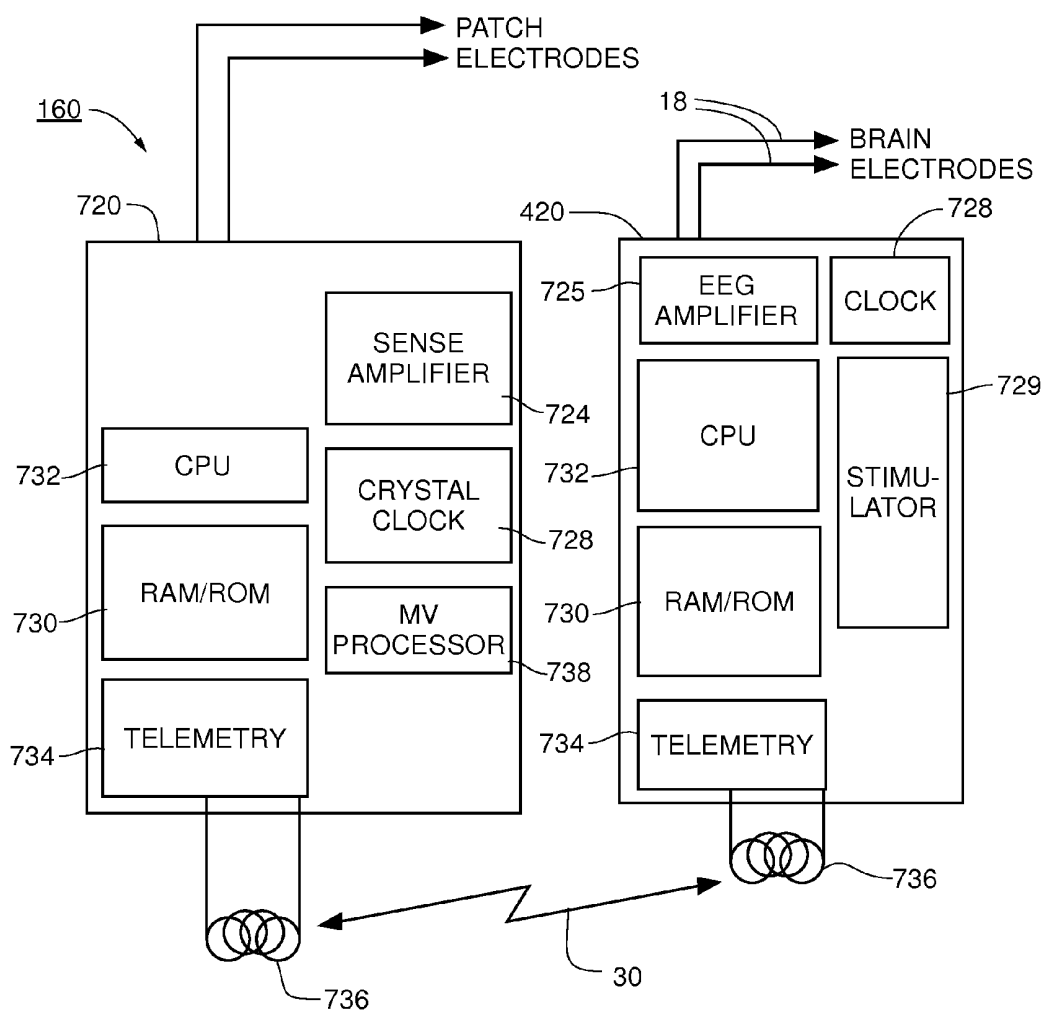
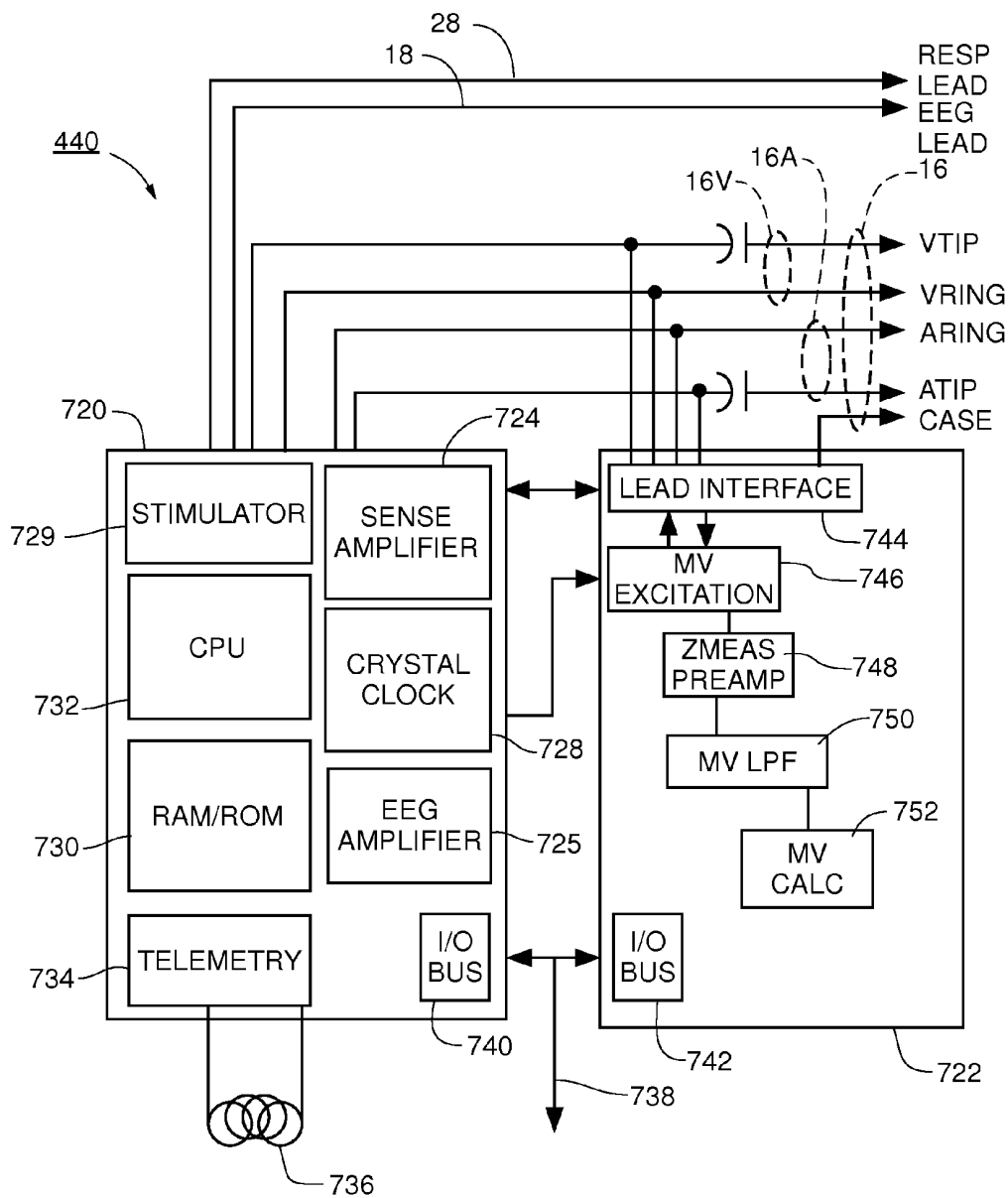


Fig. 50



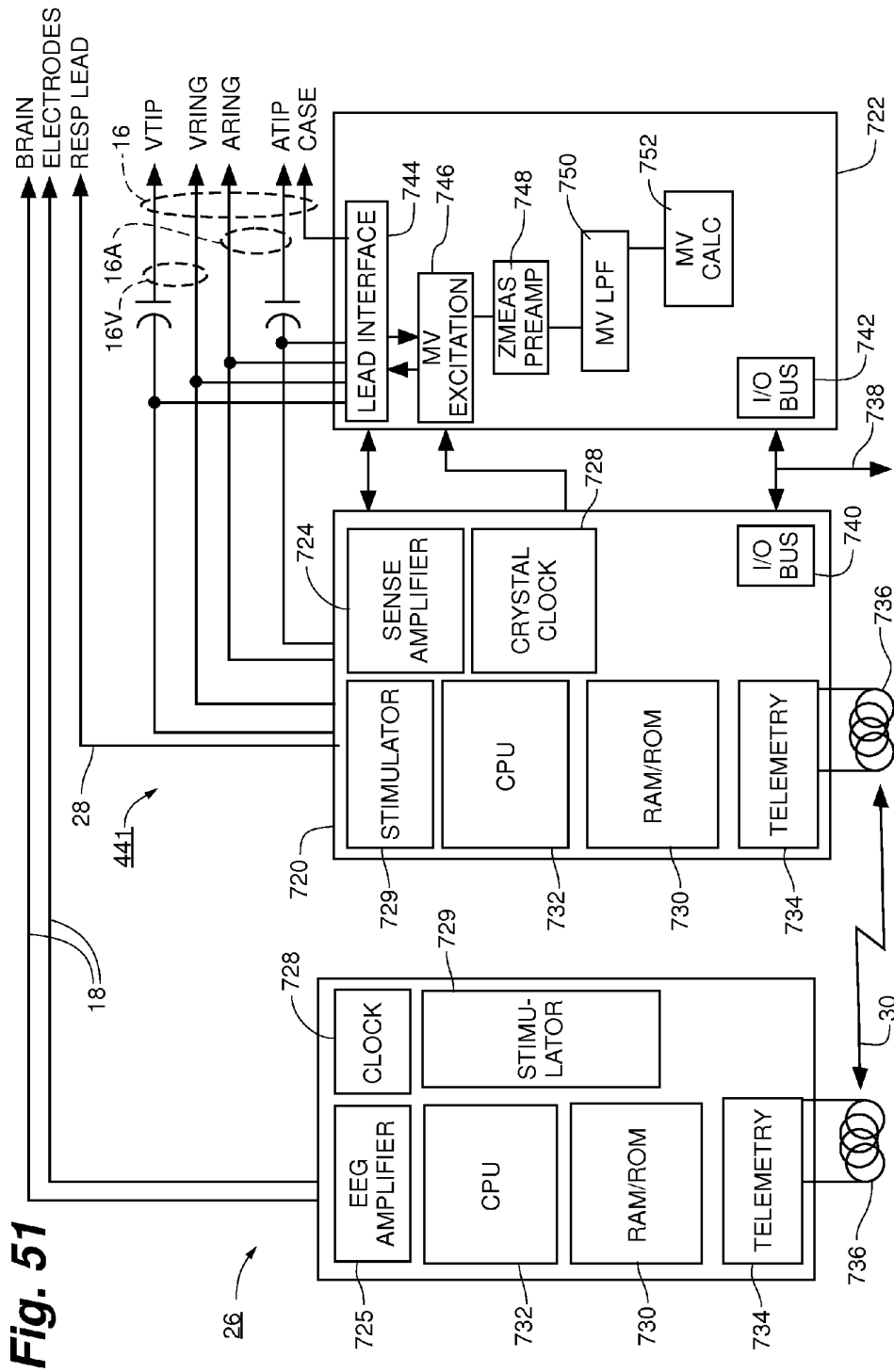
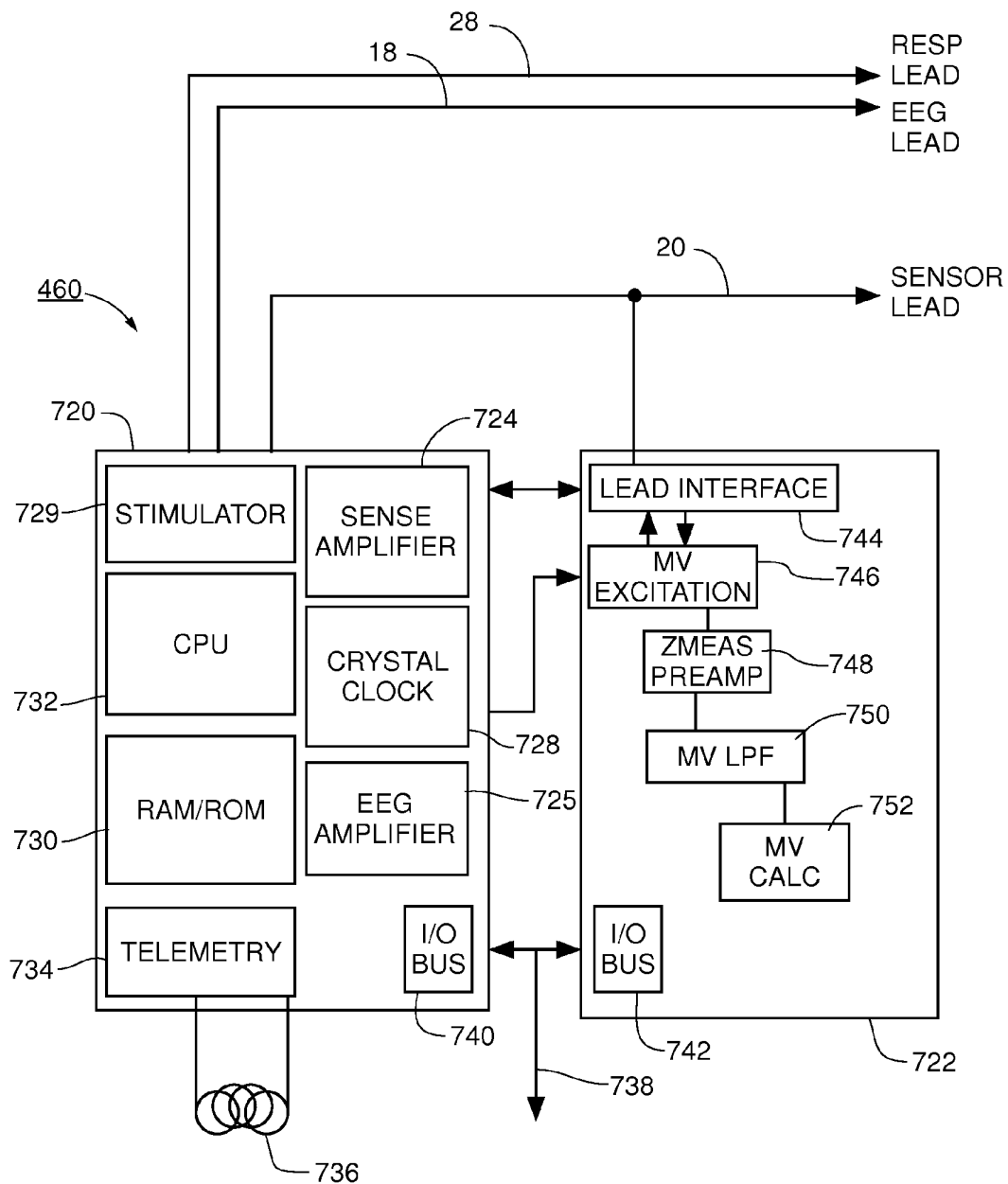
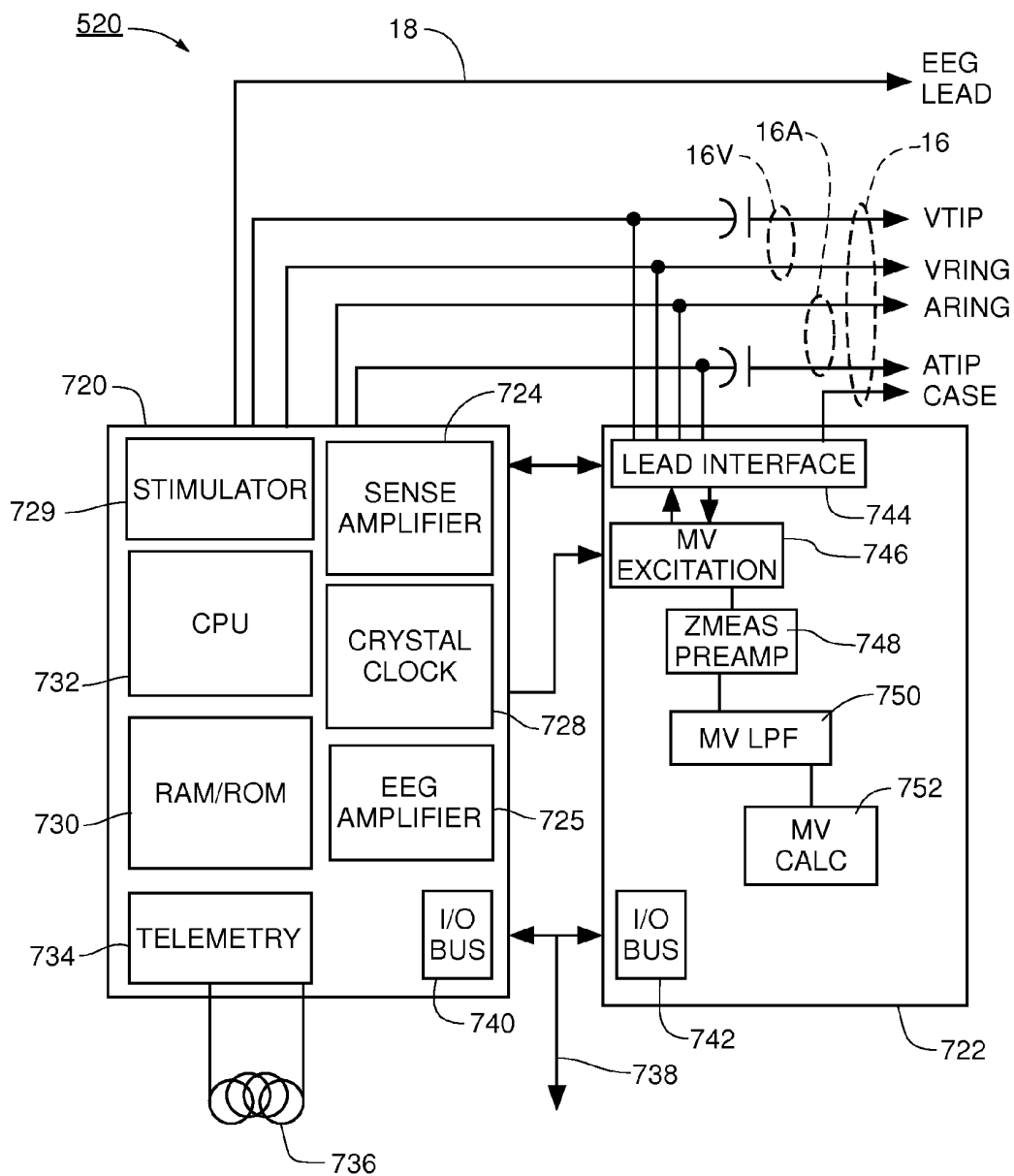


Fig. 52



**Fig. 53**



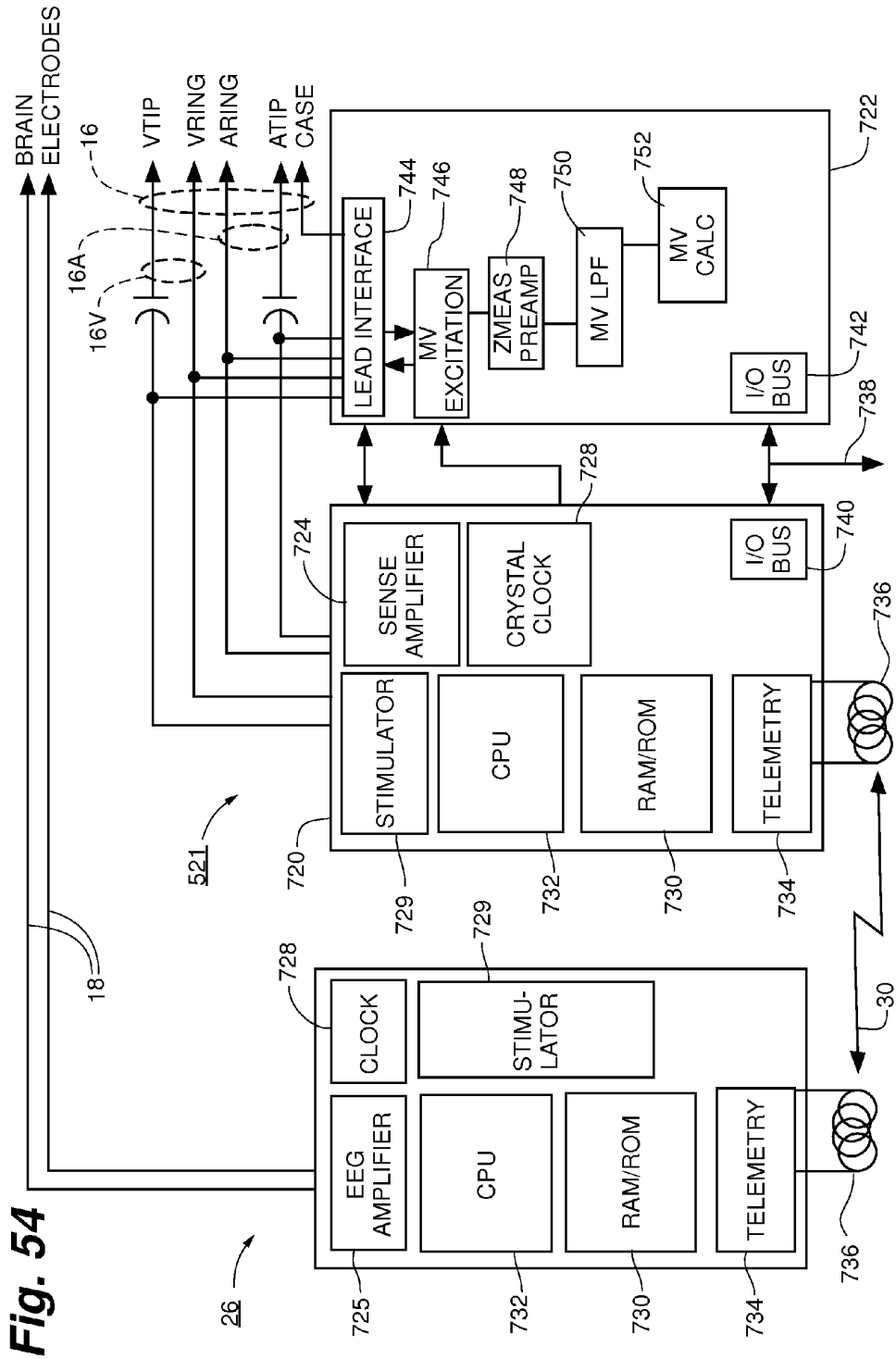


Fig. 55

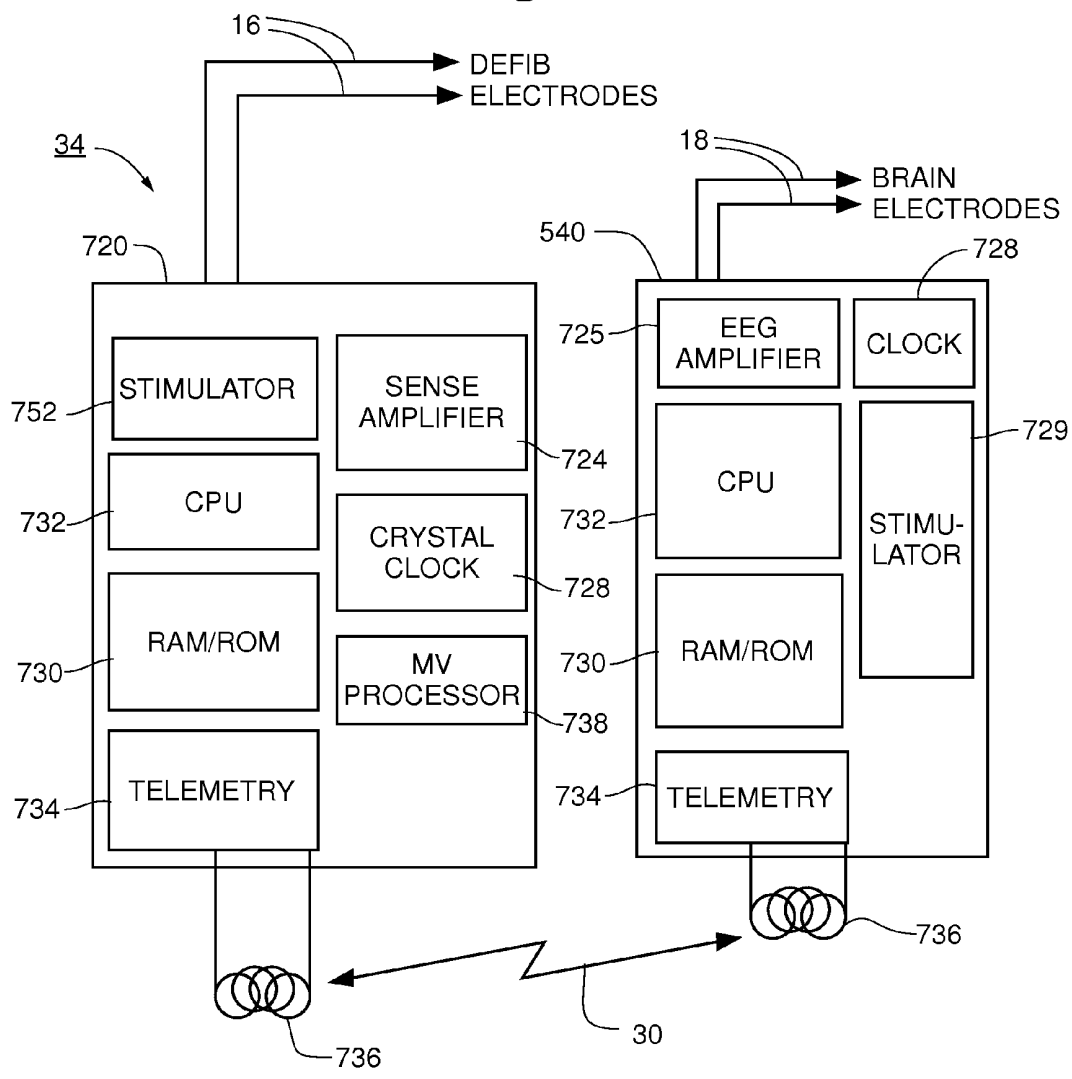
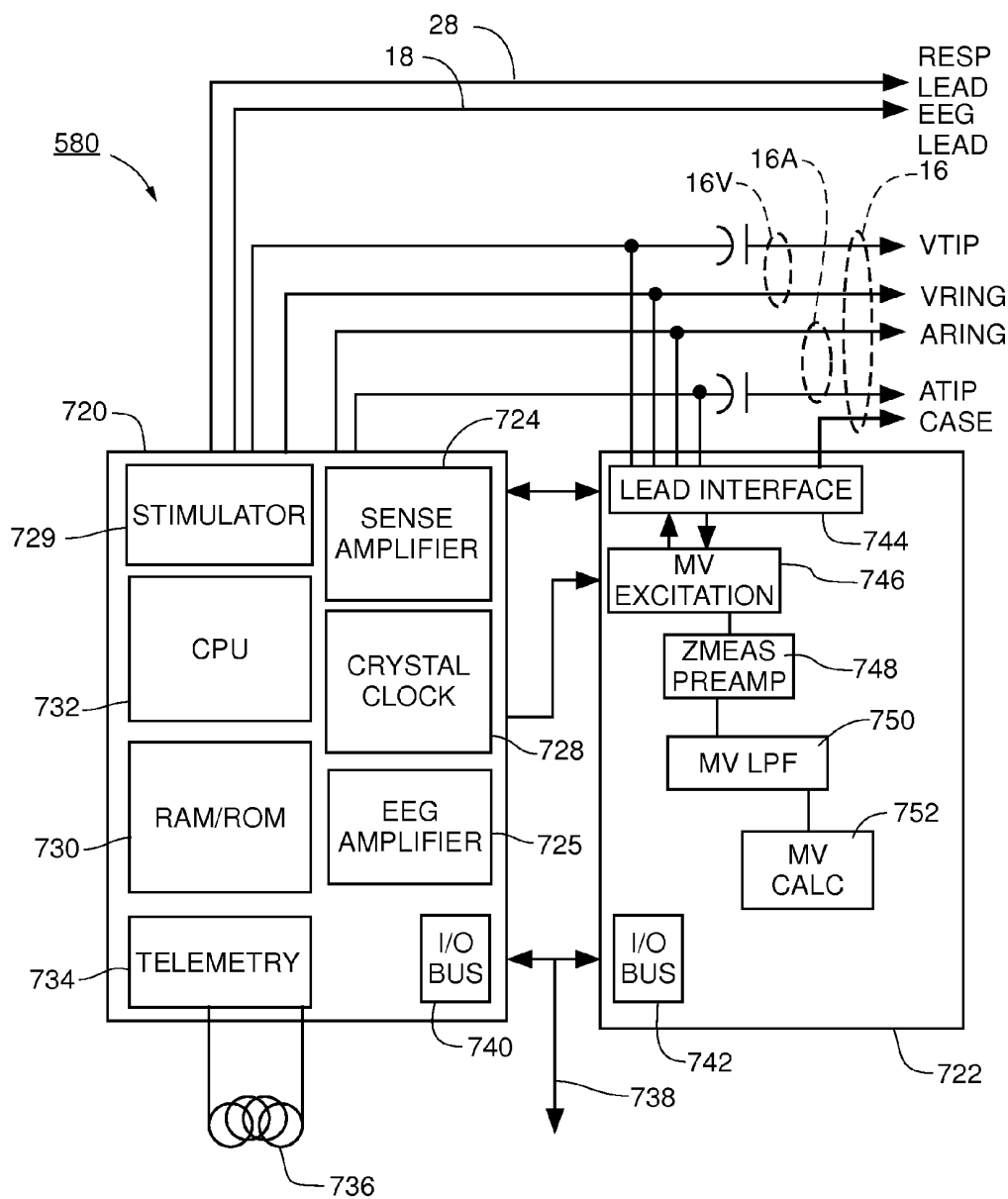


Fig. 56



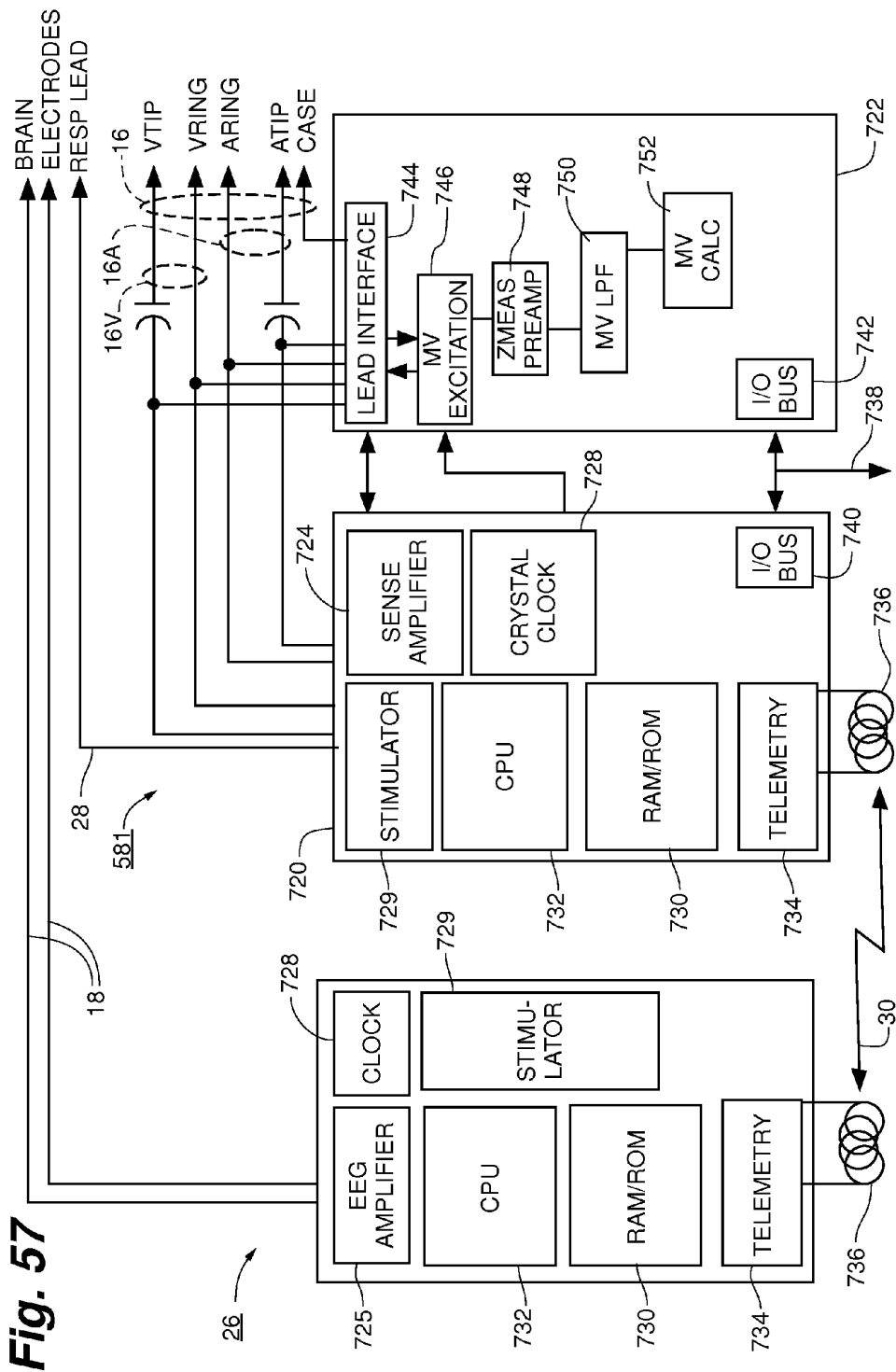
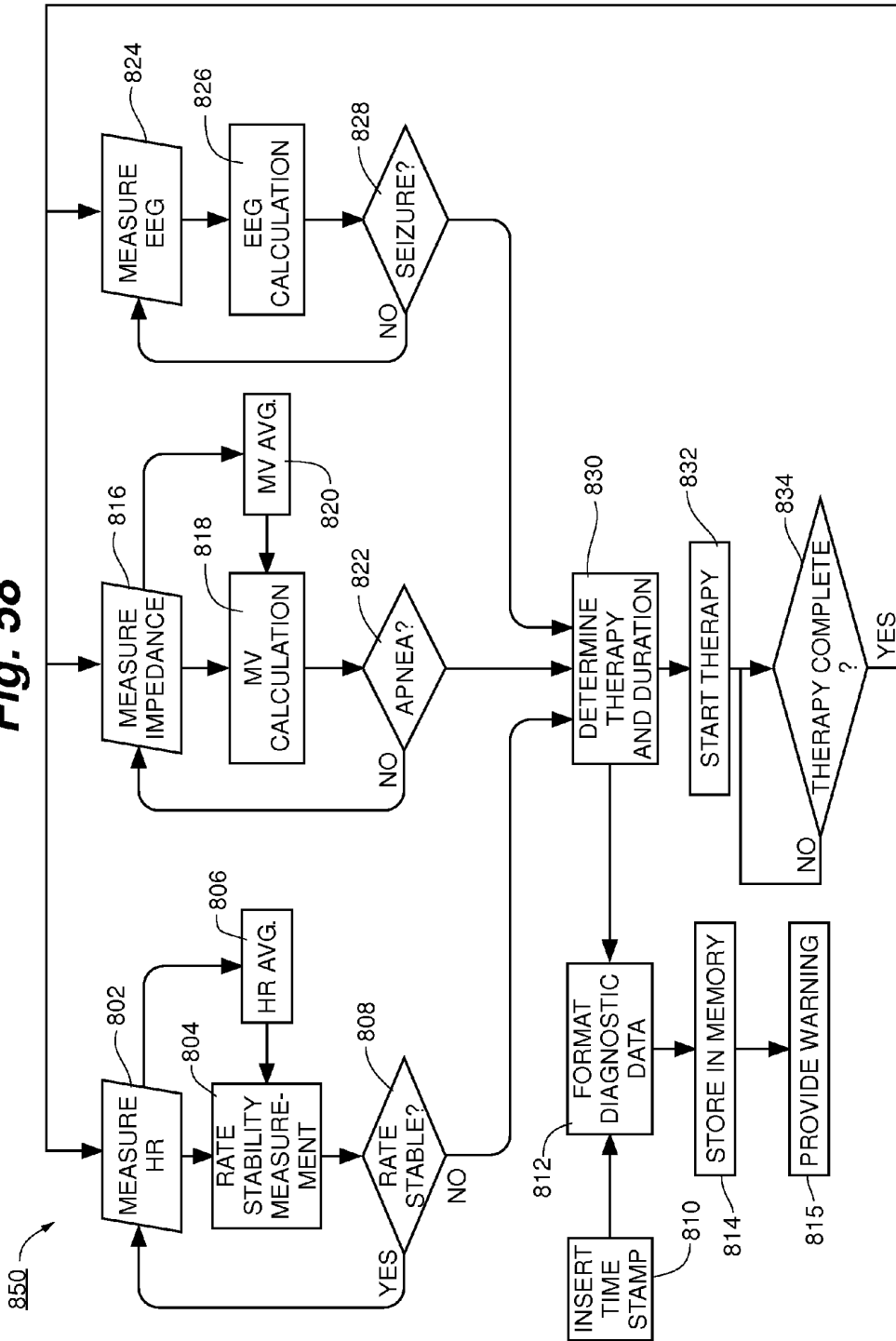
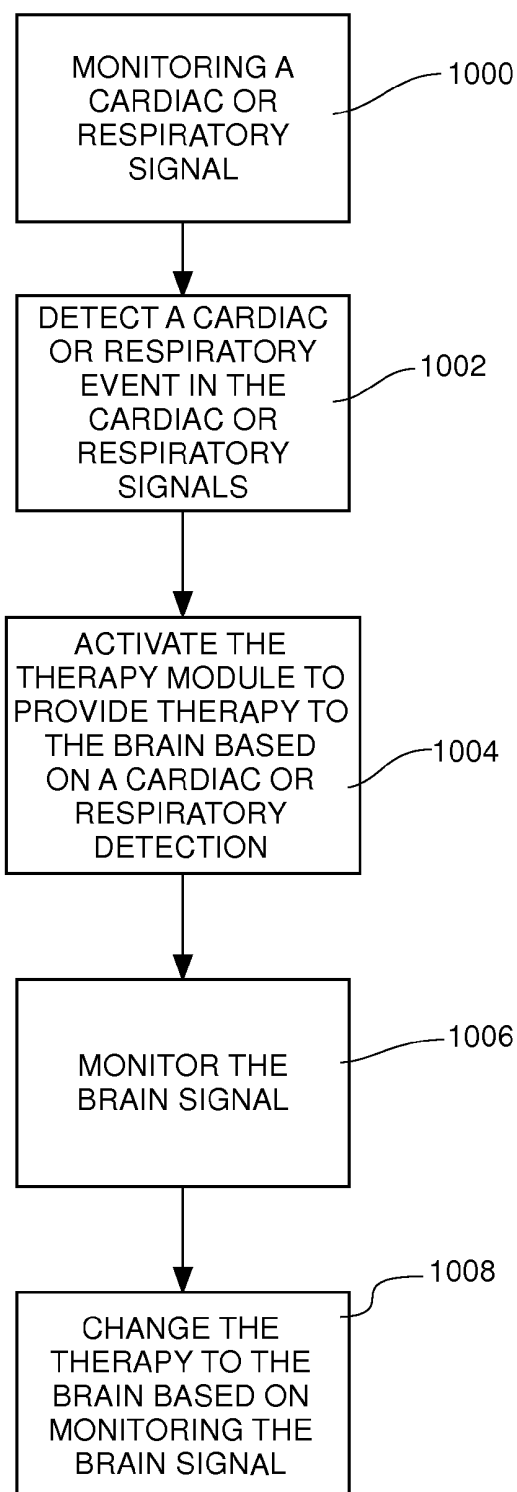
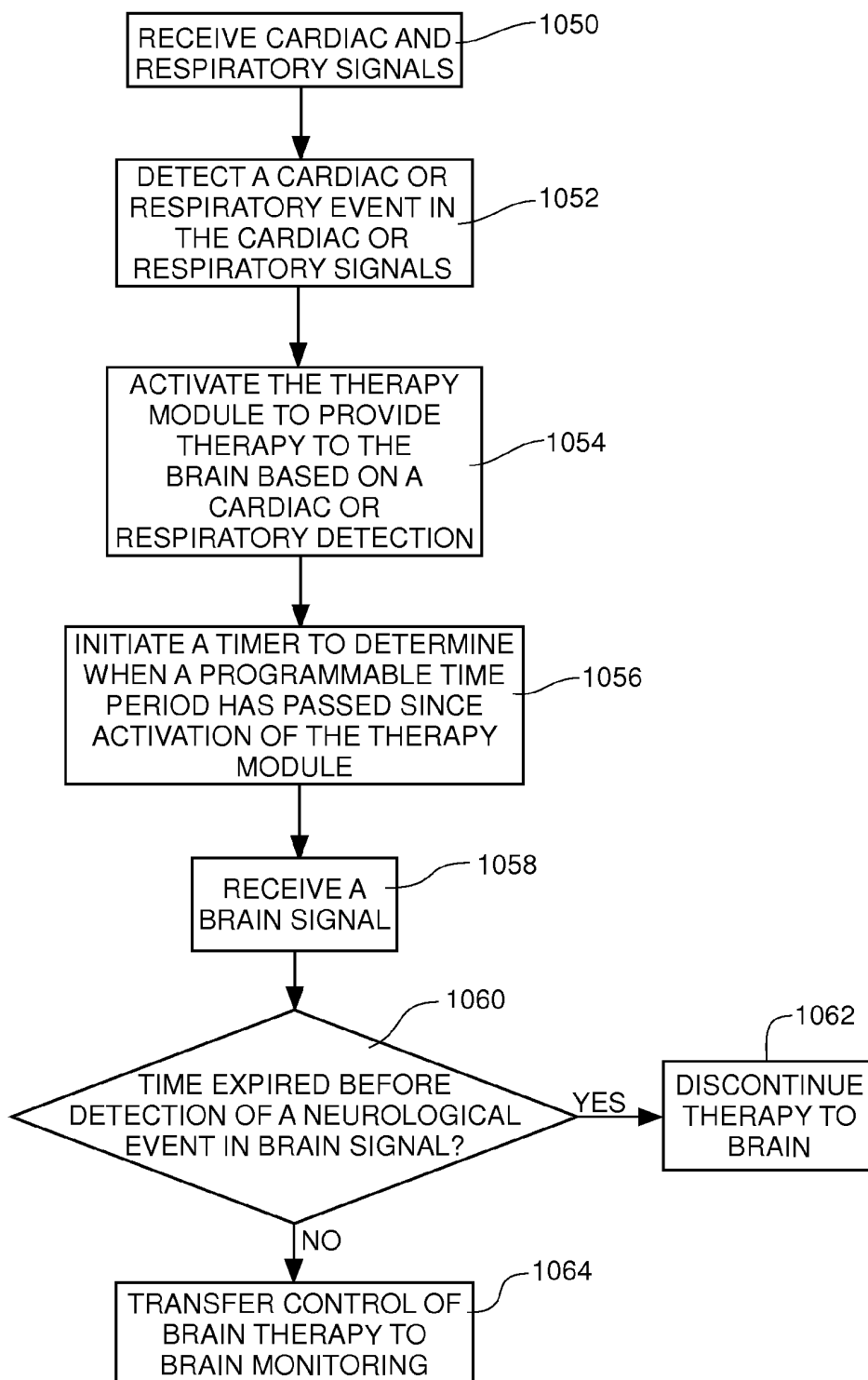


Fig. 58

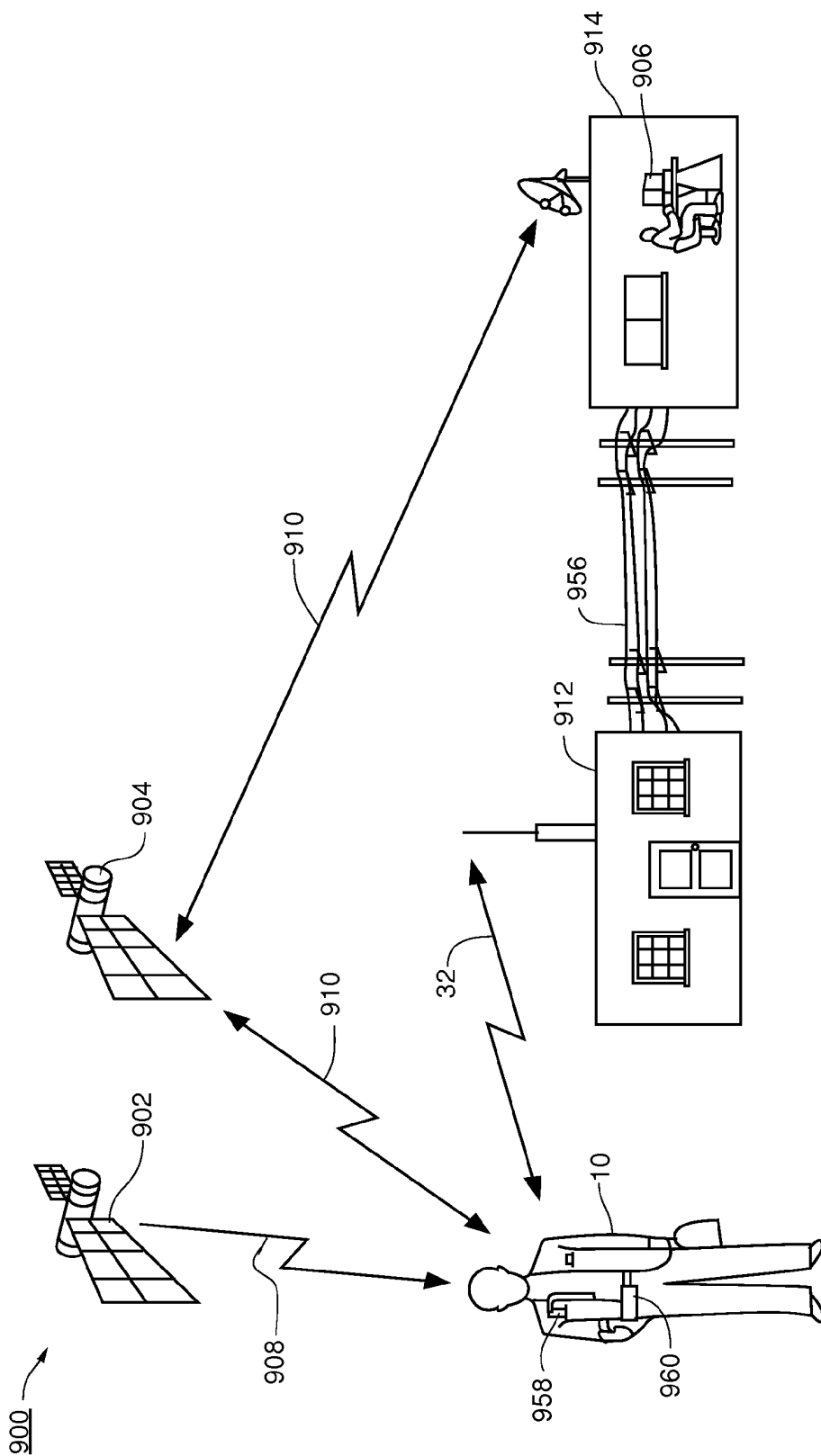


**Fig. 59A**

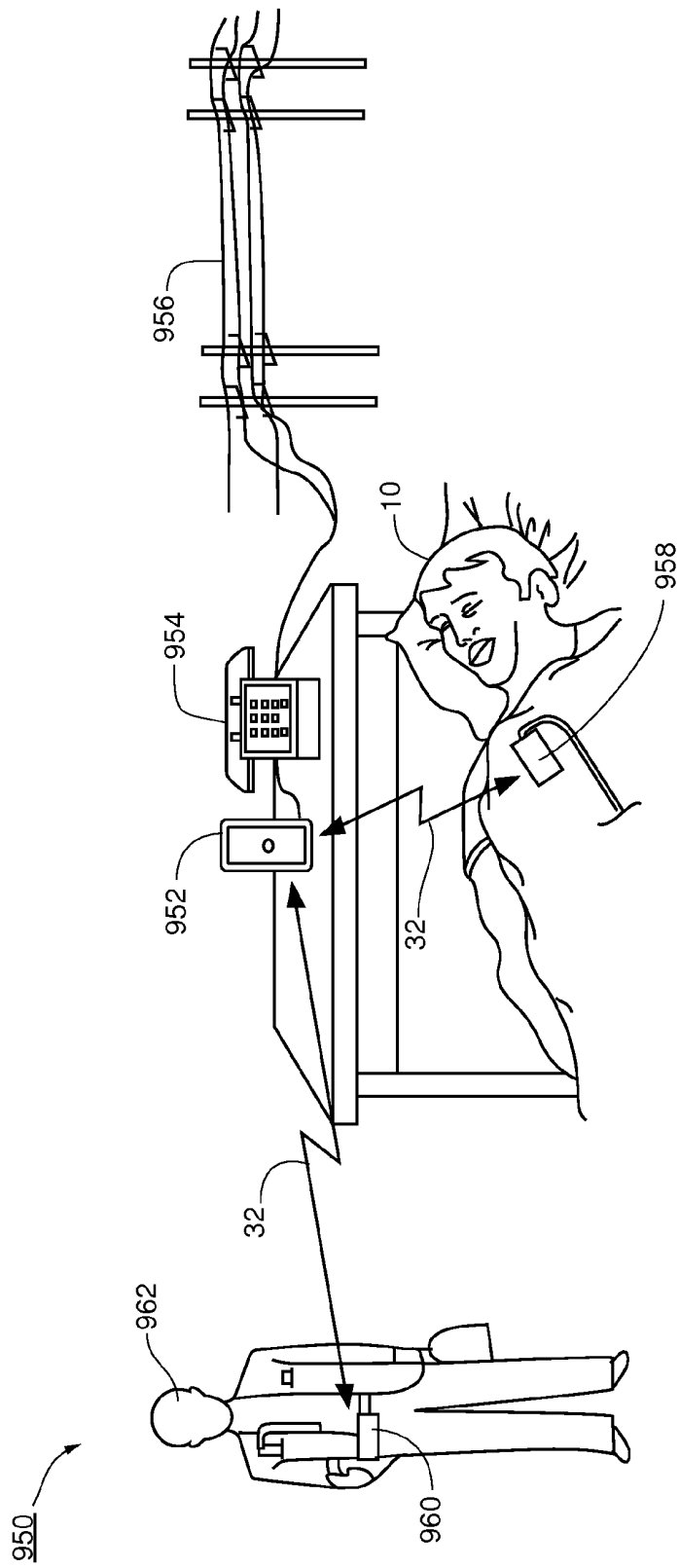
**Fig. 59B**



**Fig. 60**



**Fig. 61**



## SYSTEM AND METHOD FOR UTILIZING BRAIN STATE INFORMATION TO MODULATE CARDIAC THERAPY

### RELATED APPLICATION

This application is a continuation-in-part of U.S. application Ser. No. 11/311,043, filed Dec. 19, 2005, published as U.S. Application Publication 2006/0195144, now U.S. Pat. No. 7,865,244; a continuation-in-part of U.S. application Ser. No. 11/311,200, filed Dec. 19, 2005 now U.S. Pat. No. 8,041,418, published as U.S. Application Publication 2006/0136006, which is still pending; a continuation-in-part of U.S. application Ser. No. 11/311,393, filed Dec. 19, 2005 now U.S. Pat. No. 8,041,419, published as U.S. Application Publication 2006/0135877, which is a continuation-in-part of U.S. application Ser. No. 11,311,456, filed Dec. 19, 2005, published as U.S. Application Publication 2006/0135881, now U.S. Pat. No. 7,945,316, each of which claim the benefit of U.S. Provisional Application Ser. No. 60/636,929, filed Dec. 17, 2004, and all of which are incorporated herein by reference.

### FIELD

Embodiments of the present invention relate generally to medical devices, and more particularly, to improved monitoring of neurological and cardiac signals. Brain and cardiac events are monitored and compared. The brain state information is used to modulate the cardiac therapy. The embodiments of the invention are aimed at treating co-morbid cardiac conditions in patients being treated for a nervous system disorder.

### BACKGROUND

Nervous disorders affect millions of people, causing death and a degradation of life. Nervous system disorders include disorders of the central nervous system, peripheral nervous system, and mental health and psychiatric disorders. Such disorders include, for example, without limitation, epilepsy, Parkinson's disease, essential tremor, dystonia, and multiple sclerosis (MS).

Additionally, nervous system disorders include mental health disorders and psychiatric disorders which also affect millions of individuals and include, but are not limited to, anxiety (such as general anxiety disorder, panic disorder, phobias, post traumatic stress disorder (PTSD), and obsessive compulsive disorder (OCD), mood disorders (such as major depression, bipolar depression, and dysthymic disorder), sleep disorders (narcolepsy), eating disorders such as obesity, and anorexia. As an example, epilepsy is the most prevalent serious neurological disease across all ages. Epilepsy is a group of neurological conditions in which a person has or is predisposed to recurrent seizures. A seizure is a clinical manifestation resulting from excessive hypersynchronous, abnormal electrical or neuronal activity in the brain. A neurological event is an activity that is indicative of a nervous system disorder. A seizure is a type of neurological event. This electrical excitability of the brain may be likened to an intermittent electrical overload that manifests with sudden, recurrent and transient changes of mental function, sensations, perceptions, or involuntary body movement. Because the seizures are unpredictable, epilepsy affects a person's employability, psychosocial life, and ability to operate vehicles or power equipment. It is a disorder that occurs in all age groups, socioeconomic classes, cultures, and countries.

Nervous system disorders are often associated with co-morbid life-threatening conditions, which in some cases may have a cardiac cause. For example, a subset of epilepsy patients are at risk for SUDEP. SUDEP is defined as sudden, unexpected, often unwitnessed, non-traumatic and non-drowning death in patients for which no cause has been found except for the individual having a history of seizures. Depending on the cohort studied, SUDEP is responsible for 2% to 18% of all deaths in patients with epilepsy, and the incidence may be up to 40 times higher in young adults with epilepsy than among persons without seizures.

Although the pathophysiological mechanisms leading to death are not fully understood, experimental, autopsy and clinical evidence implicate seizure related heart and pulmonary dysfunction or indicators. Pulmonary events may include obstructive sleep apnea (OSA), central apnea, and neurogenic pulmonary edema. Cardiac events may include cardiac arrhythmic abnormalities including sinus arrhythmia, sinus pause, premature atrial contraction (PAC), premature ventricular contraction (PVC), irregular rhythm (wandering pacemaker, multifocal atrial tachycardia, atrial fibrillation), asystole or paroxysmal tachycardia. Cardiac events may also include conduction abnormalities including AV-block (AVB) and bundle branch block (BBB) and repolarization abnormalities including T-wave inversion and ST-elevation or depression. Lastly, hypertension, hypotension and vaso-vagal syncope (VVS) are common in epilepsy patients.

Epileptic seizures are associated with autonomic neuronal dysfunction that result in a broad array of abnormalities of cardiac and pulmonary function. Different pathophysiological events may contribute to SUDEP in different patients, and the mechanism is probably multifactorial. Without intervention, respiratory events, including airway obstruction, central apnea and neurogenic pulmonary edema are probably terminal events. In addition, cardiac arrhythmia and anomalies, during the ictal and interictal periods, leading to arrest and acute cardiac failure also plays an important role in potentially terminal events. For example, the paper "Electrocardiographic Changes at Seizure Onset", Leutmezer, et al, *Epilepsia* 44(3): 348-354, 2003 describes cardiovascular anomalies, such as heart rate variability (HRV), tachycardia and bradycardia, that may precede, occur simultaneous or lag behind EEG seizure onset. "Cardiac Asystole in Epilepsy: Clinical and Neurophysiologic Features", Rocamora, et al, *Epilepsia* 44(2): 179-185, 2003 reports that cardiac asystole is "provoked" by the seizure. "Electrocardiograph QT Lengthening Associated with Epileptiform EEG Discharges—a Role in Sudden Unexplained Death in Epilepsy", Tavernor, et al, *Seizure* 5(1): 79-83, March 1996 reports QT lengthening during seizures in SUDEP patients versus control. "Effects of Seizures on Autonomic and Cardiovascular Function", Devinsky *Epilepsy Currents* 4(2): 43-46, March/April 2004 describes ST segment depression and T-wave inversion, AVB, VPC and BBB during or immediately after a seizure. "Sudden Unexplained Death in Children with Epilepsy", Donner, et al, *Neurology* 57: 430-434, 2001 reports that bradycardia is frequently preceded by hypoventilation or apnea suggesting that heart rate changes during seizures may be a result of cardio-respiratory reflexes. Lastly, "EEG and ECG in Sudden Unexplained Death in Epilepsy", Nei, et al, *Epilepsia* 45(4) 338-345, 2004 reports on sinus tachycardia during or after seizures.

Patients with a psychiatric illness, such as major depressive disorder (MDD), are also at higher risk for developing cardiac problems. A strong link between depression and cardiac death has been established. Some have postulated cardiac vagal control (CVC) is impaired in patients with depression.

Others have shown major depression is associated with reduced baroreflex sensitivity (BRS), a predisposing factor for sudden cardiac death. Anxiety, which is central to OCD, has also been shown to be related with a reduction in baroreflex receptor activity. Thus, evidence suggests autonomic function is altered in depression patients, with decreased vagal activity and/or increased sympathetic arousal as possible explanations for the observed cardiac problems.

Treatment therapies for epilepsy, psychiatric illness, and other nervous system disorders can include any number of possible modalities alone or in combination including, for example, electrical stimulation, magnetic stimulation, drug infusion, and/or brain temperature control. Each of these treatment modalities can be operated using an open loop scheme, where therapy is continuously or intermittently delivered based on preprogrammed schedule. Alternatively, a closed-loop scheme may be used, in which the therapy is delivered to the patient based on information coming from a sensed signal.

An exemplary closed-loop feedback control technique includes receiving from a monitoring element a neurological signal that carries information about a symptom, a condition, or a nervous system disorder. The neurological signal can include, for example, electrical signals (such as EEG, EcoG, and/or EKG), chemical signals, other biological signals (such as change in quantity or neurotransmitters), temperature signals, pressure signals (such as blood pressure, intracranial pressure or cardiac pressure), respiration signals, heart rate signals, pH-level signals, and peripheral nerve signals (cuff electrodes on a peripheral nerve). Monitoring elements include, for example, recording electrodes or various types of sensors.

Standard diagnostic EEG sensing requires two electrodes in contact with body tissue. The first electrode is placed near the desired source of the electrical activity that the physician desires to monitor, and is referred to as active. The second electrode, referred to as the reference, is typically placed outside of the cranium away from the desired source of electrical activity. For example, the reference electrode may be attached to the ear or mastoid, or at the back of the head. Such locations are considered “inactive” since sensing from these areas produces a potential that is close to zero. In a monitoring system or device, differential amplifiers measure the voltage difference between the reference electrode and other active electrodes located within the brain. The resulting intracranial signals are amplified and displayed as channels of EEG activity.

For implantable devices that perform EEG sensing, it is desirable to have the reference electrode contained within the body. If the signals are to be used for seizure detection, it is desirable that the reference electrode be remote from the seizure focus. The active electrodes are positioned either in direct or indirect contact with brain structures affecting a neurological condition for which sensing is being performed. For example, to treat epilepsy the active electrodes may be implanted in brain tissue at or near the seizure focus where they can sense EEG signals, detect a seizure event, and provide stimulation therapy. Conversely, the active electrodes may be positioned in an anatomical target distant from the seizure focus, but which is connected to the seizure focus by way of neuronal pathway projections. Activating pathway projections with electrical stimulation from a distant site (i.e., thalamus) may influence seizure activity at the focus (i.e., hippocampus/amygdala). Similarly, to treat a psychiatric illness such as major depressive disorder or OCD, the active electrodes may be implanted directly in brain tissue involved in mood regulation for depression or OCD, such as the inter-

nal capsule or subgenual cingulate cortex (Area 25). Alternatively, the active electrodes may be positioned at distant sites within the limbic-cortical circuit, which have connections to these mood regulating regions of the brain. With either approach, it is desirable to have a single electrode positioned away from the active electrodes, which can function as a reference for EEG sensing and/or function as an indifferent electrode for monopolar stimulation.

For patients being treated for a neurological condition, it is desirable to further refine the monitoring and treatment of neurological events, and when appropriate, provide treatment for co-morbid cardiac detected events. To achieve this, what is desired is a neurostimulation device that treats neurological conditions while monitoring the patient’s cardiac state, with provisions to enable cardiac therapy if deemed necessary.

In addition, for some patients it would be beneficial to be able to regulate the cardiac therapy using brain state information, particularly in cases where the change in cardiac state is part of the neurological event. For example, some changes in heart rate function during a neurological event, such as a seizure or panic attack (i.e., tachy episodes, brief asystolic pauses, etc.) are considered normal—the body’s reaction to dealing with the event—and do not necessitate cardiac treatment. Inadvertent pacemaker activation during such episodes may interfere with physiological processes aimed at terminating them. Thus, means to regulate the cardiac therapy during seizures and other neurological states would be beneficial.

Currently, there are no neurological devices that perform these functions.

#### SUMMARY

In all embodiments of this invention, it is possible to modulate the cardiac therapy controller using brain state information from the EEG signals. In one mode of operation, the cardiac therapy controller is modulated when a neurological event is first detected. In another mode, cardiac events which have been identified as being temporally matched with a neurological event (cardiac-neurological match), and thus have an established expectancy, are modulated. The latter allows for therapy modulation of a cardiac event without having to wait for the neurological event to begin or occur. Modulation may take several forms, including temporally suspending the cardiac therapy during the neurological event; triggering the cardiac therapy at a higher threshold and/or longer duration of detection; and, providing a different type of pacing or defibrillation therapy during the neurological event. The physician is also able to define cardiac treatment options, which determine the types of cardiac events to be treated in different brain states. If the modulated cardiac event being treated does not terminate, normal cardiac therapy is resumed.

#### BRIEF DESCRIPTION OF THE DRAWINGS

##### Core Monitor

FIG. 1 is a simplified schematic view of a thoracic cavity leadless medical device implanted in a patient that monitors cardiac and respiratory parameters relating to a nervous system disorder.

FIG. 2 is a simplified schematic view of an alternative embodiment cardiac leadless medical device implanted in a patient that monitors cardiac and respiratory parameters relating to nervous system disorder.

FIG. 3 is a simplified schematic view of an alternative embodiment sensor stub medical device implanted in a



## Detailed Design

FIG. 26 is a simplified block diagram of a core monitor as shown in FIG. 1 above.

FIG. 27 is a graphical representation of the signals sensed by core monitor as shown in FIG. 1 above.

FIG. 28 is a simplified block diagram of a core monitor as shown in FIG. 2 above.

FIG. 29 is a simplified block diagram of a core monitor as shown in FIG. 3 above.

FIG. 30 is a simplified block diagram of a core monitor as shown in FIG. 4 above.

FIG. 31 is a flow diagram showing operation of a core monitor as shown in FIG. 1-4 above.

FIG. 32 is a simplified block diagram of a full monitor as shown in FIG. 5 above.

FIG. 33 is a simplified block diagram of a full monitor as shown in FIG. 6 above.

FIG. 34 is a simplified block diagram of a full monitor as shown in FIGS. 7 and 9 above.

FIG. 35 is a simplified block diagram of a full monitor as shown in FIG. 8 above.

FIG. 36 is a simplified block diagram of a full monitor as shown in FIG. 10 above.

FIG. 37 is a flow diagram showing operation of a full monitor as shown in FIG. 5-10 above.

FIG. 38 is a diagram of exemplary physiologic data from a patient with a full monitor as shown in relation to FIG. 5-10 above.

FIG. 39 shows a process for identifying ECG and respiratory abnormalities recorded during detected seizures in a full monitor as shown in relation to FIG. 5-10 above.

FIG. 40A shows a process for enabling the cardiac or respiratory detectors for neurological event detection in a full monitor as shown in relation to FIG. 5-10 above and detection/treatment as described in FIG. 41-51 below.

FIG. 40B shows a process for enabling the ECG or respiratory detectors for seizure detection in a full monitor as shown in relation to FIG. 5-10 above and detection/treatment as described in FIG. 41-51 below.

FIG. 41 is a flow chart of a cardiac modulation technique utilizing detected neurological events.

FIGS. 42A and B are flow charts of a cardiac modulation technique utilizing temporal relationship between cardiac and neurological events.

FIG. 43 is a simplified block diagram of a full monitor with brain stimulation therapy as shown in FIG. 11 above.

FIG. 44 is a simplified block diagram of a full monitor with brain stimulation therapy as shown in FIG. 12A above.

FIG. 45 is a simplified block diagram of a full monitor with brain stimulation therapy as shown in FIG. 12B above.

FIG. 46 is a simplified block diagram of a full monitor with brain stimulation therapy as shown in FIGS. 13 and 15 above.

FIG. 47 is a simplified block diagram of a full monitor with brain stimulation therapy as shown in FIG. 14 above.

FIG. 48 is a simplified block diagram of a full monitor with brain stimulation therapy as shown in FIG. 20 above.

FIG. 49 is a simplified block diagram of a full monitor with brain stimulation therapy as shown in FIG. 21 above.

FIG. 50 is a simplified block diagram of a full monitor with brain and respiration stimulation therapy as shown in FIG. 16A above.

FIG. 51 is a simplified block diagram of a full monitor with brain and respiration stimulation therapy as shown in FIG. 16B above.

FIG. 52 is a simplified block diagram of a full monitor with brain and respiration stimulation therapy as shown in FIGS. 17, 18 and 19 above.

FIG. 53 is a simplified block diagram of a full monitor with brain and cardiac stimulation therapy as shown in FIG. 24A above.

FIG. 54 is a simplified block diagram of a full monitor with brain and cardiac stimulation therapy as shown in FIG. 24B above.

FIG. 55 is a simplified block diagram of a full monitor with brain and cardiac stimulation therapy as shown in FIGS. 22 and 23 above.

FIG. 56 is a simplified block diagram of a full monitor with brain, respiration and cardiac stimulation therapy as shown in FIG. 25A above.

FIG. 57 is a simplified block diagram of a full monitor with brain, respiration and cardiac stimulation therapy as shown in FIG. 25B above.

FIG. 58 is a flow diagram showing operation of a full monitor with therapy (including brain, respiration or cardiac stimulation therapy) as shown in FIG. 11-25 above.

FIG. 59A is a flow diagram showing a process for enabling cardiac/respiratory detectors for neurological event detection and treatment including termination rules.

FIG. 59B is a flow diagram showing a process for enabling ECG/respiratory detectors for seizure detection and treatment including termination rules.

FIG. 60 is a schematic diagram of a system utilizing any of the above-described embodiments and allowing remote monitoring and diagnostic evaluation of at risk patients.

FIG. 61 is a schematic diagram of an alternative system utilizing any of the above-described embodiments and allowing remote monitoring and diagnostic evaluation of at risk patients.

## DETAILED DESCRIPTION OF THE INVENTION

The following detailed description is merely exemplary in nature and is not intended to limit the embodiments of the invention or the application and uses of the embodiments of the invention. Furthermore, there is no intention to be bound by any expressed or implied theory presented in the preceding technical field, background, brief summary or the following detailed description.

The term "brain monitoring element" used herein means any device, component or sensor that receives a physiologic signal from the brain or head of a patient and outputs a brain signal that is based upon the sensed physiologic signal. Some examples of a brain monitoring element include leads, electrodes, chemical sensors, biological sensors, pressure sensors, and temperature sensors. A monitoring element does not have to be located in the brain to be a brain monitoring element. The term brain monitoring element is not the same as the term "monitor" also used herein, although a brain monitoring element could be a part of a monitor.

The term "cardiac monitoring element" used herein means any device, component or sensor that receives or infers a physiological signal from the heart of a patient and outputs a cardiac signal that is based upon sensed physiologic signal. Some examples of cardiac monitoring elements include leads, electrodes, chemical sensors, biological sensor, pressure sensors and temperature sensors. A monitoring element does not have to be located in the heart or adjacent to the heart to be a cardiac monitoring element. For example, a sensor or electrode adapted for sensing a cardiac signal and placed on the housing of an implantable device is a cardiac monitoring element. Furthermore, a cardiac monitoring element could be an externally placed sensor such as a holter monitoring system. The term "cardiac monitoring element" is not the same

as the term “monitor” also used herein although a cardiac monitoring element could be a part of a monitor.

The term “respiratory monitoring element” used herein means any device, component or sensor that receives a physiologic signal indicative of activity or conditions in the lungs of a patient and outputs a respiration signal that is based upon the sensed physiologic signal. Some examples of respiration monitoring elements are provided below. A monitoring element does not have to be located in the lungs or adjacent to the lungs to be a respiratory monitoring element. The term “respiratory monitoring element” is not the same as the term “monitor” also used herein although a respiratory monitoring element could be a part of a monitor.

It is noted that many embodiments of the invention may reside on any hardware embodiment currently understood or conceived in the future. Many example hardware embodiments are provided in this specification. These examples are not meant to be limiting of the invention.

#### Core Monitor

Cardiopulmonary monitoring in the Core Monitor device (as described below in more detail in conjunction with FIGS. 1-4 and 26-30) monitors cardiac (e.g., ECG, blood pressure) or respiration signals continuously and records these signals in a loop recorder either automatically or manually when the patient indicates they have had a neurological event such as a seizure. Real-time analysis of the ECG signal evaluates rate disturbances (e.g., bradycardia; tachycardia; asystole) as well as any indications of cardiac ischemia (e.g., ST segment changes; T wave inversion, etc.). Real-time analysis of the respiration signal evaluates respiration disturbances (e.g., respiration rate, minute ventilation, apnea, prolonged pauses).

Abnormalities detected during real-time analysis will lead to an immediate patient alert. This alert can be audible (beeps, buzzers, tones, spoken voice, etc.), light, tactile, or other means.

Automatic loop recording may save the data for a programmable period of time. For example, the device may be programmed to save a period of time before a cardiac detection (e.g., 30 seconds of ECG raw or processed data before detection) and a second period of time after the detection (e.g., 3 minutes of ECG raw or processed data after detection).

The medical device system may also include a manual activation mode in which the patient provides an indication (e.g., push a button on a holter, patient programmer or other external patient activator device) when a neurological event is occurring or has just occurred. In manual activation mode, to allow for the fact that the patient may not mark the neurological event until the neurological event has ended, the ECG loop recording may begin a longer time period before the event is marked. For example, the medical device system may save ECG data beginning 15 minutes before the patient mark. This time period may be programmable. Post-processing of this saved signal will analyze the data to evaluate heart rate changes during the neurological event, heart rate variability and changes in ECG waveforms. Manual patient indication of a neurological event will be done through the patient external activator device 22. The patient (or caregiver) will push a button on the external device, while communicating with the implanted device. This will provide a marker and will initiate a loop recording. In addition, prolonged ECG loop recordings are possible (e.g., in the case of SUDEP, recording all data during sleep since the incidence of SUDEP is highest in patients during sleep).

Post-processing of the signal can occur in the implanted device, the patient’s external device or in the clinician external device. Intermittently (e.g., every morning, once/week,

following a neurological event), the patient may download data from the implantable device to the patient external device. This data will then be analyzed by the external device (or sent through a network to the physician) to assess any ECG or respiratory abnormalities. If an abnormality is detected, the device will notify the patient/caregiver. At that time, the patient/caregiver or device can inform the healthcare provider of the alert to allow a full assessment of the abnormality. The clinician external device is also capable of obtaining the data from the implanted device and conducting an analysis of the stored signals. If a potentially life-threatening abnormality is detected, the appropriate medical treatment can be prescribed (e.g., cardiac abnormality: a pacemaker, an implantable defibrillator, or a heart resynchronization device may be indicated or respiration abnormality: CPAP, patient positioning, or stimulation of respiration may be indicated).

FIG. 1 is a simplified schematic view of one embodiment of a core Monitor 100 implanted in a patient 10. Monitor 100 continuously senses and monitors the cardiac and respiration function of patient 10 via one or more monitoring elements 14 (e.g., cardiac electrodes) to allow detection of neurological events, the recording of data and signals pre and post event. Stored diagnostic data is uplinked and evaluated by the patient’s physician utilizing programmer 12 via a 2-way telemetry link 32. An external patient activator 22 may optionally allow the patient 10, or other care provider (not shown), to manually activate the recording of diagnostic data.

Monitor 100, as stated above, typically includes one or more monitoring elements 14 such as several subcutaneous spiral electrodes that are embedded individually into three or four recessed casings placed in a compliant surround that is attached to the perimeter of implanted monitor 100 as substantially described in U.S. Pat. No. 6,512,940 “Subcutaneous Spiral Electrode for Sensing Electrical Signals of the Heart” to Brabec, et al and U.S. Pat. No. 6,522,915 “Surround Shroud Connector and Electrode Housings for a Subcutaneous Electrode Array and Leadless ECGs” to Ceballos, et al. These electrodes are electrically connected to the circuitry of the implanted Monitor 100 to allow the detection of cardiac depolarization waveforms (as substantially described in U.S. Pat. No. 6,505,067 “System and Method for Deriving a Virtual ECG or EGM Signal” to Lee, et al.) that may be further processed to detect cardiac electrical characteristics (e.g., heart rate, heart rate variability, arrhythmias, cardiac arrest, sinus arrest and sinus tachycardia). Further processing of the cardiac signal amplitudes may be used to detect respiration characteristics (e.g., respiration rate, minute ventilation, and apnea).

To aid in the implantation of Monitor 100 in a proper position and orientation, an implant aid may be used to allow the implanting physician to determine the proper location/orientation as substantially described in U.S. Pat. No. 6,496,715 “System and Method for Noninvasive Determination of Optimal Orientation of an Implantable Sensing Device” to Lee, et al.

FIG. 2 is a simplified schematic view of a second embodiment core Monitor 120 implanted in a patient 10. Monitor 120 continuously senses and monitors cardiac and respiration function of patient 10 via cardiac lead(s) 16 to allow detection of neurological events and the recording of data and signals pre and post event. Stored diagnostic data is uplinked and evaluated by the patient’s physician utilizing programmer 12 via a 2-way telemetry link 32. An external patient activator 22 may optionally allow the patient 10, or other care provider (not shown), to manually activate the recording of diagnostic data. Monitor 120 senses both cardiac signals and respiration parameters via standard cardiac leads implanted in the heart.

Monitor **120** measures intra-cardiac impedance, varying both with the intrathoracic pressure fluctuations during respiration and with cardiac contraction is representative of the pulmonary activity and of the cardiac activity as substantially described in U.S. Pat. No. 5,003,976 "Cardiac and Pulmonary Physiological Analysis via Intracardiac Measurements with a Single Sensor" to Alt. Cardiac leads **16** may consist of any typical lead configuration as is known in the art, such as, without limitation, right ventricular (RV) pacing or defibrillation leads, right atrial (RA) pacing or defibrillation leads, single pass RA/RV pacing or defibrillation leads, coronary sinus (CS) pacing or defibrillation leads, left ventricular pacing or defibrillation leads, pacing or defibrillation epicardial leads, subcutaneous defibrillation leads, unipolar or bipolar lead configurations, or any combinations of the above lead systems.

FIG. 3 is a simplified schematic view of a third embodiment core Monitor **140** implanted in a patient **10**. Monitor **140** continuously senses and monitors cardiac and respiration function of patient **10** via an electrode (not shown) located distally on sensor stub **20** which is inserted subcutaneously in the thoracic area of the patient to allow detection of neurological events and the recording of data and signals pre and post event. Stored diagnostic data is uplinked and evaluated by the patient's physician utilizing programmer **12** via a 2-way telemetry link **32**. An external patient activator **22** may optionally allow the patient **10**, or other care provider (not shown), to manually activate the recording of diagnostic data. Monitor **140** senses cardiac signals between an electrode on the distal end of the sensor stub and the monitor case as described in conjunction with the embodiment shown in FIG. 5 in U.S. Pat. No. 5,987,352 "Minimally Invasive Implantable Device for Monitoring Physiologic Events" to Klein, et al. Monitor **140** also senses respiration parameters such as respiration rate, minute ventilation and apnea via measuring and analyzing the impedance variations measured from the implanted monitor **140** case to the electrode (not shown) located distally on sensor stub lead **20** as substantially described in U.S. Pat. No. 4,567,892 "Implantable Cardiac Pacemaker" and U.S. Pat. No. 4,596,251 "Minute Ventilation Dependent Rate Responsive Pacer" both to Plicchi, et al.

FIG. 4 is a simplified schematic view of a fourth embodiment core Monitor **160** attached to a patient **10**. External patch Monitor **160** continuously senses and monitors cardiac and respiration function of patient **10** to allow detection of neurological events and the recording of data and signals pre and post event. Stored diagnostic data is uplinked and evaluated by the patient's physician utilizing programmer **12** via a 2-way telemetry link **32**. An external patient activator **22** may optionally allow the patient **10**, or other care provider (not shown), to manually activate the recording of diagnostic data. Also optionally, a button **38** on the external patch monitor **160** may be activated by the patient **10** to manually activate diagnostic data recording.

External patch Monitor **160** consists of a resilient substrate affixed to the patient's skin with the use of an adhesive which provides support for an amplifier, memory, microprocessor, receiver, transmitter and other electronic components as substantially described in U.S. Pat. No. 6,200,265 "Peripheral Memory Patch and Access Method for Use With an Implantable Medical Device" to Walsh, et al. The substrate flexes in a complimentary manner in response to a patient's body movements providing patient comfort and wearability. The low profile external patch Monitor **160** is preferably similar in size and shape to a standard bandage, and may be attached to the patient's skin in an inconspicuous location. Uplinking of stored physiologic telemetry data from the internal memory

of external patch Monitor **160** may be employed to transfer information between the monitor and programmer **12**.

#### Full Monitor

The term "full monitor" is used to describe a monitor that is capable of monitoring the brain (such as by monitoring a brain signal such as an electroencephalogram (EEG)) and additionally the heart or pulmonary system or both. This will allow the full monitor to collect neurological signals and at least one of the cardiovascular and respiratory signals in close proximity to neurological events detected (such as seizures) as well as notifying the patient/caregiver of a prolonged neurological event (such as status epilepticus). Cardiovascular and respiratory monitoring may occur around a neurological event (in the case of a seizure this is called peri-stimulation). In distinction from the core monitor, in which patients/caregivers must notify the device that a neurological event has occurred, the full monitor device will detect the neurological event (based on the brain signal) and will automatically analyze the peri-stimulation signals and initiate the loop recording. Monitoring of more than one physiologic signal allows for greater understanding of the total physiologic condition of the patient. For example, prolonged or generalized seizures put patients at higher risk for SUDEP, the EEG monitoring may be programmed to provide alerts when a neurological event has exceeded a pre-determined duration or severity.

FIG. 5 is a simplified schematic view of a full Monitor **200** implanted in a patient **10**. Monitor **200** continuously senses and monitors cardiac, brain and respiration function of patient **10** via one or more brain monitoring elements **18** and one or more cardiac monitoring elements **14** or one or more respiratory monitoring elements **15**. Brain monitoring elements **18** may be for example, one or more brain leads with one or more electrodes. Such a brain lead may be any lead capable of sensing brain activity such as EEG. For example, brain monitoring element **18** may be a deep brain lead, a cortical lead or an electrode placed on the head externally. Cardiac monitoring elements **14** may be cardiac leads or other types of sensors or electrodes capable of picking up cardiac signals. These monitoring elements allow detection of a neurological event and the recording of data and signals pre and post event. Stored diagnostic data is uplinked and evaluated by the patient's physician utilizing programmer **12** via a 2-way telemetry link **32**. An external patient activator **22** may optionally allow the patient **10**, or other care provider (not shown), to manually activate the recording of diagnostic data. An implant aid may be used with Monitor **200** to ensure a proper position and orientation during implant as described above in connection with the system of FIG. 1.

FIG. 6 is a simplified schematic view of a second embodiment of a full Monitor **220** implanted in a patient **10**. Monitor **220** continuously senses and monitors cardiac, brain and respiration function of patient **10** via cardiac lead(s) **16** and a brain lead **18** to allow detection of a neurological event and the recording of data and signals pre and post event. Stored diagnostic data is uplinked and evaluated by the patient's physician utilizing programmer **12** via a 2-way telemetry link **32**. An external patient activator **22** may optionally allow the patient **10**, or other care provider (not shown), to manually activate the recording of diagnostic data.

FIG. 7 is a simplified schematic view of a third embodiment of a full Monitor **240** implanted in a patient **10**. Monitor **240** continuously senses and monitors cardiac, brain and respiration function of patient **10** via sensor stub **20** and brain lead **18** to allow detection of a neurological event and the recording of data and signals pre and post event. Stored diagnostic data is uplinked and evaluated by the patient's physician utilizing programmer **12** via a 2-way telemetry link **32**.

An external patient activator **22** may optionally allow the patient **10**, or other care provider (not shown), to manually activate the recording of diagnostic data.

FIG. **8** is a simplified schematic view of a fourth embodiment of a full Monitor **260** implanted in a patient **10**. Monitor **260** in combination with external patch **160** continuously senses and monitors cardiac, brain and respiration function of patient **10** to allow detection of a neurological event and the recording of data and signals pre and post event. A 2-way wireless telemetry communication link **30** connects the Monitor unit **260** and external patch **160**. The wireless communication link **30** may consist of an RF link (such as described in U.S. Pat. No. 5,683,432 "Adaptive Performance-Optimizing Communication System for Communicating with an Implantable Medical Device" to Goedeke, et al), an electromagnetic/ionic transmission (such as described in U.S. Pat. No. 4,987,897 "Body Bus Medical Device Communication System" to Funke) or acoustic transmission (such as described in U.S. Pat. No. 5,113,859 "Acoustic Body Bus Medical Device Communication System" to Funke). Stored diagnostic data is uplinked and evaluated by the patient's physician utilizing programmer **12** via a 2-way telemetry link **32**. An external patient activator **22** may optionally allow the patient **10**, or other care provider (not shown), to manually activate the recording of diagnostic data. Also optionally, a button **38** on the external patch monitor **160** may be activated by the patient **10** to manually activate diagnostic data recording.

An alternative embodiment of the system of FIG. **8** consists of software "patches" or programs downloaded from a wearable patch **38** into an implanted neurostimulator, drug pump or monitor to allow research evaluation of new therapies, detection algorithms, clinical research and data gathering and the use of the patient as their own "control" by randomly downloading or enabling a new detection algorithm or therapy and gathering the resultant clinical data (as substantially described in U.S. Pat. No. 6,200,265 "Peripheral Memory Patch and Access Method for Use with an Implantable Medical Device" to Walsh, et al). The clinical and diagnostic data may be uploaded into the memory of the patch for later retrieval and review by the patient's physician or device clinical manager. This embodiment also allows the upgrading of the existing implant base with temporary new or additional therapeutic and diagnostic features.

FIG. **9** is a simplified schematic view of a fifth embodiment of a full Monitor **280** implanted in a patient **10**. Monitor **280** continuously senses and monitors cardiac, brain and respiration function of patient **10** via brain lead **18** with integrated electrode **24** to allow detection of a neurological event and the recording of data and signals pre and post event. Stored diagnostic data is uplinked and evaluated by the patient's physician utilizing programmer **12** via a 2-way telemetry link **32**. An external patient activator **22** may optionally allow the patient **10**, or other care provider (not shown), to manually activate the recording of diagnostic data. Integrated electrode **24** senses ECG signals as described above in the referenced Klein '352 patent and respiration signals as described above in the referenced Plicchi '892 and '251 patents.

FIG. **10** is a simplified schematic view of a sixth embodiment of a full Monitor **26** implanted cranially in a patient **10**. Monitor **26** continuously senses and monitors cardiac, brain and respiration function of patient **10** to allow detection of a neurological event and the recording of data and signals pre and post event. Stored diagnostic data is uplinked and evaluated by the patient's physician utilizing programmer **12** via a 2-way telemetry link **32**. An external patient activator **22** may

optionally allow the patient **10**, or other care provider (not shown), to manually activate the recording of diagnostic data.

Monitor **26** may be constructed as substantially described in U.S. Application Publication 2004/0176817, now U.S. Pat. No. 7,212,864, issued May 1, 2007 to Walstrand et al. and entitled "Modular implantable medical device" or U.S. Pat. Nos. 5,782,891 "Implantable Ceramic Enclosure for Pacing, Neurological and Other Medical Applications in the Human Body" to Hassler, et al or 6,427,086 "Means and Method for the Intracranial Placement of a Neurostimulator" to Fischell, et al. EEG sensing is accomplished by the use of integrated electrodes in the housing of monitor **26** or, alternatively, by cranially implanted leads.

ECG sensing in the cranium may be accomplished by leadless ECG sensing as described in the above Brabec '940, Ceballos '915 and Lee '067 referenced patents. Alternatively, ECG rate and asystole may be inferred (along with a blood pressure signal) from a capacitive dynamic pressure signal (i.e., dP/dt) as substantially described in U.S. Pat. No. 4,485,813 "Implantable Dynamic Pressure Transducer System" to Anderson, et al. ECG rate and asystole may be inferred by monitoring an acoustic signal (i.e., sound) as substantially described in U.S. Pat. No. 5,554,177 "Method and Apparatus to Optimize Pacing Based on Intensity of Acoustic Signal" to Kieval, et al. The sensed acoustic signal is low pass filtered to limit ECG signals to 0.5-3 Hz while filtering out speech, swallowing and chewing sounds. ECG rate and asystole may be inferred (along with a blood saturation measurement) by monitoring a reflectance oximetry signal (i.e., O<sub>2</sub>sat) as substantially described in U.S. Pat. No. 4,903,701 "Oxygen Sensing Pacemaker" to Moore, et al. ECG rate and asystole may be inferred by monitoring a blood temperature signal (i.e., dT/dt) as substantially described in U.S. Pat. No. 5,336,244 "Temperature Sensor Based Capture Detection for a Pacer" to Weijand. ECG rate and asystole may be inferred (along with an arterial flow measurement) by monitoring a blood flow signal (from an adjacent vein via impedance plethysmography, piezoelectric sensor or Doppler ultrasound) as substantially described in U.S. Pat. No. 5,409,009 "Methods for Measurement of Arterial Blood Flow" to Olson. ECG rate and asystole may be inferred (along with a blood pressure measurement) by monitoring a blood pressure signal utilizing a strain gauge substantially described in U.S. Pat. No. 5,168,759 "Strain Gauge for Medical Applications" to Bowman. ECG rate and asystole may be inferred by monitoring a blood parameter sensor (such as oxygen, pulse or flow) located on a V-shaped lead as substantially described in U.S. Pat. No. 5,354,318 "Method and Apparatus for Monitoring Brain Hemodynamics" to Taepke.

Monitor **26** may warn or alert the patient **10** via an annunciator such as buzzes, tones, beeps or spoken voice (as substantially described in U.S. Pat. No. 6,067,473 "Implantable Medical Device Using Audible Sound Communication to Provide Warnings" to Greeninger, et al.) via a piezo-electric transducer incorporated in the housing of monitor **26** and transmitting sound to the patient's **10** inner ear.

Monitor+Treatment (Brain)

FIG. **11** is a simplified schematic view of a full Monitor/Brain Therapy unit **300** implanted in a patient **10**. Monitor/Brain Therapy unit **300** continuously senses and monitors cardiac, brain and respiration function of patient **10** via monitoring elements **14** and **18**. Such monitoring elements may be subcutaneous electrodes and a brain lead to allow detection of a neurological event, the recording of data and signals pre and post event, and the delivery of therapy via brain lead. Stored diagnostic data is uplinked and evaluated by the patient's physician utilizing programmer **12** via a 2-way telemetry link

32. An external patient activator 22 may optionally allow the patient 10, or other care provider (not shown), to manually activate the recording of diagnostic data and delivery of therapy. An implant aid may be used with Monitor/Brain Therapy device 300 to assist with positioning and orientation during implant as described above in connection with the system of FIG. 1.

FIG. 12A is a simplified schematic view of a second embodiment of a full Monitor/Brain Therapy unit 320 implanted in a patient 10. Monitor/Brain Therapy unit 320 continuously senses and monitors cardiac, brain and respiration function of patient 10 via cardiac lead(s) 16 and a brain lead 18 to allow detection of a neurological event, the recording of data and signals pre and post event, and the delivery of therapy via brain lead 18. Stored diagnostic data is uplinked and evaluated by the patient's physician utilizing programmer 12 via a 2-way telemetry link 32. An external patient activator 22 may optionally allow the patient 10, or other care provider (not shown), to manually activate the recording of diagnostic data and delivery of therapy.

FIG. 12B is a simplified schematic view of a third embodiment of a full Monitor/Brain Therapy system consisting of a thoracically implanted Monitor unit 321 in combination with a cranially implanted brain Monitor/Therapy unit 26. Monitor unit 321 continuously senses and monitors the cardiac and respiration function of patient 10 via cardiac lead(s) 16 to allow detection of a neurological event, the recording of data and signals pre and post event, and the delivery of therapy via Monitor/Therapy unit 26. A 2-way wireless telemetry communication link 30 connects the Monitor/Therapy unit 26 and cardiac/respiration monitor 321. The wireless communication link 30 may consist of an RF link (such as described in U.S. Pat. No. 5,683,432 "Adaptive Performance-Optimizing Communication System for Communicating with an Implantable Medical Device" to Goedeke, et al), an electromagnetic/ionic transmission (such as described in U.S. Pat. No. 4,987,897 "Body Bus Medical Device Communication System" to Funke) or acoustic transmission (such as described in U.S. Pat. No. 5,113,859 "Acoustic Body Bus Medical Device Communication System" to Funke). Monitor 26 may be constructed as substantially described in U.S. Application Publication 2004/0176817, now U.S. Pat. No. 7,212,864, issued May 1, 2007 to Walstrand et al. and entitled "Modular implantable medical device" or U.S. Pat. Nos. 5,782,891 "Implantable Ceramic Enclosure for Pacing, Neurological and Other Medical Applications in the Human Body" to Hassler, et al or 6,427,086 "Means and Method for the Intracranial Placement of a Neurostimulator" to Fischell, et al. EEG sensing and brain stimulation is accomplished by the use of integrated electrodes in the housing of Monitor/Therapy unit 26 or, alternatively, by cranially implanted leads (not shown in FIG. 12B). Stored diagnostic data is uplinked and evaluated by the patient's physician utilizing programmer 12 via a 2-way telemetry link 32. An external patient activator 22 may optionally allow the patient 10, or other care provider (not shown), to manually activate the recording of diagnostic data and delivery of therapy.

FIG. 13 is a simplified schematic view of a fourth embodiment of a full Monitor/Brain Therapy unit 340 implanted in a patient 10. Monitor/Brain Therapy unit 340 continuously senses and monitors cardiac, brain and respiration function of patient 10 via sensor stub 20 and a brain lead 18 to allow detection of a neurological event such as a neurological event, the recording of data and signals pre and post event, and the delivery of therapy via brain lead 18. Stored diagnostic data is uplinked and evaluated by the patient's physician utilizing programmer 12 via a 2-way telemetry link 32. An external

patient activator 22 may optionally allow the patient 10, or other care provider (not shown), to manually activate the recording of diagnostic data and delivery of therapy.

FIG. 14 is a simplified schematic view of a fifth embodiment of a full Monitor/Brain Therapy unit 360 implanted in a patient 10. Monitor/Brain Therapy unit 360 in combination with external patch 160 continuously senses and monitors cardiac, brain and respiration function of patient 10 via external patch 160 and a brain lead 18 to allow detection of neurological events, the recording of data and signals pre and post event, and the delivery of therapy via brain lead 18. A 2-way wireless telemetry communication link 30 connects the Monitor/Brain Therapy unit 360 and external patch 160. The wireless communication link 30 may consist of an RF link (such as described in U.S. Pat. No. 5,683,432 "Adaptive Performance-Optimizing Communication System for Communicating with an Implantable Medical Device" to Goedeke, et al), an electromagnetic/ionic transmission (such as described in U.S. Pat. No. 4,987,897 "Body Bus Medical Device Communication System" to Funke) or acoustic transmission (such as described in U.S. Pat. No. 5,113,859 "Acoustic Body Bus Medical Device Communication System" to Funke). Stored diagnostic data is uplinked and evaluated by the patient's physician utilizing programmer 12 via a 2-way telemetry link 32. An external patient activator 22 may optionally allow the patient 10, or other care provider (not shown), to manually activate the recording of diagnostic data and delivery of therapy. Also optionally, a button 38 on the external patch monitor 160 may be activated by the patient 10 to manually activate diagnostic data recording and therapy delivery.

FIG. 15 is a simplified schematic view of a sixth embodiment of a full Monitor/Brain Therapy unit 380 implanted in a patient 10. Monitor/Brain Therapy unit 380 continuously senses and monitors cardiac, brain and respiration function of patient 10 via a brain lead 18 with integrated electrode 24 to allow detection of neurological events, the recording of data and signals pre and post event, and the delivery of therapy via brain lead 18. Stored diagnostic data is uplinked and evaluated by the patient's physician utilizing programmer 12 via a 2-way telemetry link 32. An external patient activator 22 may optionally allow the patient 10, or other care provider (not shown), to manually activate the recording of diagnostic data and delivery of therapy. Integrated electrode 24 senses ECG signals as described above in the referenced Klein '352 patent and respiration signals as described above in the referenced Plicchi '892 and '251 patents.

FIG. 20 is a simplified schematic view of a seventh embodiment of a full Monitor/Brain Therapy unit 26 implanted cranially in a patient 10. Monitor/Brain Therapy unit 26 in combination with leadless Monitor 400 continuously senses and monitors cardiac, brain and respiration function of patient 10 to allow detection of neurological events, the recording of data and signals pre and post event, and the delivery of therapy via brain lead 18. Stored diagnostic data is uplinked and evaluated by the patient's physician utilizing programmer 12 via a 2-way telemetry link 32. An external patient activator 22 may optionally allow the patient 10, or other care provider (not shown), to manually activate the recording of diagnostic data and delivery of therapy. A 2-way wireless telemetry communication link 30 connects the Monitor/Therapy unit 26 and leadless Monitor 400. The wireless communication link 30 may consist of an RF link (such as described in U.S. Pat. No. 5,683,432 "Adaptive Performance-Optimizing Communication System for Communicating with an Implantable Medical Device" to Goedeke, et al), an electromagnetic/ionic transmission (such as described in U.S. Pat. No. 4,987,897 "Body Bus Medical Device Communica-

tion System” to Funke) or acoustic transmission (such as described in U.S. Pat. No. 5,113,859 “Acoustic Body Bus Medical Device Communication System” to Funke). An implant aid may be used with Monitor device **400** to ensure a proper position and orientation during implant as described above in connection with the system of FIG. 1. Monitor **26** may be constructed as substantially described in U.S. Application Publication 2004/0176817, now U.S. Pat. No. 7,212,864, issued May 1, 2007 to Walstrand et al. and entitled “Modular implantable medical device” or U.S. Pat. Nos. 5,782,891 “Implantable Ceramic Enclosure for Pacing, Neurological and Other Medical Applications in the Human Body” to Hassler, et al or 6,427,086 “Means and Method for the Intracranial Placement of a Neurostimulator” to Fischell, et al. EEG sensing is accomplished by the use of integrated electrodes in the housing of monitor **26** or, alternatively, by cranially implanted leads.

Monitor **26** may warn/alert the patient **10** via an annunciator such as, but not limited to, buzzes, tones, beeps or spoken voice (as substantially described in U.S. Pat. No. 6,067,473 “Implantable Medical Device Using Audible Sound Communication to Provide Warnings” to Greeninger, et al.) via a piezo-electric transducer incorporated in the housing of monitor **26** and transmitting sound to the patient’s **10** inner ear.

FIG. **21** is a simplified schematic view of an eighth embodiment of a full Monitor/Brain Therapy unit **420** implanted cranially in a patient **10**. Monitor/Brain Therapy unit **400** in combination with external patch core monitor **160** continuously senses and monitors cardiac, brain and respiration function of patient **10** to allow detection of neurological events, the recording of data and signals pre and post event, and the delivery of therapy via brain lead **18**. Stored diagnostic data is uplinked and evaluated by the patient’s physician utilizing programmer **12** via a 2-way telemetry link **32**. An external patient activator **22** may optionally allow the patient **10**, or other care provider (not shown), to manually activate the recording of diagnostic data and delivery of therapy. A 2-way wireless telemetry communication link **30** connects the Monitor/Therapy unit **26** and leadless Monitor **400**. The wireless communication link **30** may consist of an RF link (such as described in U.S. Pat. No. 5,683,432 “Adaptive Performance-Optimizing Communication System for Communicating with an Implantable Medical Device” to Goedeke, et al), an electromagnetic/ionic transmission (such as described in U.S. Pat. No. 4,987,897 “Body Bus Medical Device Communication System” to Funke) or acoustic transmission (such as described in U.S. Pat. No. 5,113,859 “Acoustic Body Bus Medical Device Communication System” to Funke).

Monitor **26** may be constructed as substantially described in U.S. Application Publication 2004/0176817, now U.S. Pat. No. 7,212,864, issued May 1, 2007 to Walstrand et al. and entitled “Modular implantable medical device” or U.S. Pat. Nos. 5,782,891 “Implantable Ceramic Enclosure for Pacing, Neurological and Other Medical Applications in the Human Body” to Hassler, et al or 6,427,086 “Means and Method for the Intracranial Placement of a Neurostimulator” to Fischell, et al. EEG sensing is accomplished by the use of integrated electrodes in the housing of monitor **26** or, alternatively, by cranially implanted leads.

Monitor **26** may warn/alert the patient **10** via an annunciator such as, but not limited to, buzzes, tones, beeps or spoken voice (as substantially described in U.S. Pat. No. 6,067,473 “Implantable Medical Device Using Audible Sound Communication to Provide Warnings” to Greeninger, et al.) via a

piezo-electric transducer incorporated in the housing of monitor **26** and transmitting sound to the patient’s **10** inner ear.

Monitor+Treatment (Brain+Respiration)

FIG. **16A** is a simplified schematic view of a full Monitor/Brain and Respiration Therapy unit **440** implanted in a patient **10**. Monitor/Brain and Respiration Therapy unit **440** continuously senses and monitors cardiac brain and respiration function of patient **10** via cardiac lead(s) **16** and a brain lead **18** to allow detection of neurological events, the recording of data and signals pre and post event, and the delivery of therapy via brain lead **18** and phrenic nerve lead **28**. Stored diagnostic data is uplinked and evaluated by the patient’s physician utilizing programmer **12** via a 2-way telemetry link **32**. An external patient activator **22** may optionally allow the patient **10**, or other care provider (not shown), to manually activate the recording of diagnostic data and delivery of therapy. Optionally, lead **28** may connect to the diaphragm to provide direct diaphragmatic stimulation.

FIG. **16B** is a simplified schematic view of a second embodiment of a full Monitor/Brain and Respiration Therapy system consisting of a thoracically implanted Monitor/Respiration Therapy unit **441** in combination with a cranially implanted brain Monitor/Therapy unit **26**. Monitor unit **441** continuously senses and monitors the cardiac and respiration function of patient **10** via cardiac lead(s) **16** to allow detection of neurological events, the recording of data and signals pre and post event, the delivery of respiration therapy via phrenic nerve lead **28** and the delivery of brain stimulation via Monitor/Therapy unit **26**. A 2-way wireless telemetry communication link **30** connects the Monitor/Therapy unit **26** and cardiac/respiration monitor and respiration therapy unit **441**. The wireless communication link **30** may consist of an RF link (such as described in U.S. Pat. No. 5,683,432 “Adaptive Performance-Optimizing Communication System for Communicating with an Implantable Medical Device” to Goedeke, et al), an electromagnetic/ionic transmission (such as described in U.S. Pat. No. 4,987,897 “Body Bus Medical Device Communication System” to Funke) or acoustic transmission (such as described in U.S. Pat. No. 5,113,859 “Acoustic Body Bus Medical Device Communication System” to Funke). Monitor **26** may be constructed as substantially described in U.S. Application Publication 2004/0176817, now U.S. Pat. No. 7,212,864, issued May 1, 2007 to Walstrand et al. and entitled “Modular implantable medical device” or U.S. Pat. Nos. 5,782,891 “Implantable Ceramic Enclosure for Pacing, Neurological and Other Medical Applications in the Human Body” to Hassler, et al or 6,427,086 “Means and Method for the Intracranial Placement of a Neurostimulator” to Fischell, et al. EEG sensing and brain stimulation is accomplished by the use of integrated electrodes in the housing of monitor **26** or, alternatively, by cranially implanted leads (not shown in FIG. **16B**). Stored diagnostic data is uplinked and evaluated by the patient’s physician utilizing programmer **12** via a 2-way telemetry link **32**. An external patient activator **22** may optionally allow the patient **10**, or other care provider (not shown), to manually activate the recording of diagnostic data and delivery of therapy. Optionally, lead **28** may connect to the diaphragm to provide direct diaphragmatic stimulation.

FIG. **17** is a simplified schematic view of a third embodiment of a full Monitor/Brain and Respiration Therapy unit **460** implanted in a patient **10**. Monitor/Brain and Respiration Therapy unit **460** continuously senses and monitors cardiac, brain and respiration function of patient **10** via sensor stub **20** and a brain lead **18** to allow detection of neurological events, the recording of data and signals pre and post event, and the

delivery of therapy via brain lead **18** and phrenic nerve lead **28**. Stored diagnostic data is uplinked and evaluated by the patient's physician utilizing programmer **12** via a 2-way telemetry link **32**. An external patient activator **22** may optionally allow the patient **10**, or other care provider (not shown), to manually activate the recording of diagnostic data and delivery of therapy. Optionally, lead **28** may connect to the diaphragm to provide direct diaphragmatic stimulation.

FIG. **18** is a simplified schematic view of a fourth embodiment of a full Monitor/Brain and Respiration Therapy unit **480** implanted in a patient **10**. Monitor/Brain and Respiration Therapy unit **480** continuously senses and monitors cardiac, brain and respiration function of patient **10** via a brain lead **18** with integrated electrode **24** to allow detection of neurological events, the recording of data and signals pre and post event, and the delivery of therapy via brain lead **18** and phrenic nerve lead **28**. Stored diagnostic data is uplinked and evaluated by the patient's physician utilizing programmer **12** via a 2-way telemetry link **32**. An external patient activator **22** may optionally allow the patient **10**, or other care provider (not shown), to manually activate the recording of diagnostic data and delivery of therapy. Optionally, lead **28** may connect to the diaphragm to provide direct diaphragmatic stimulation. Integrated electrode **24** senses ECG signals as described above in the referenced Klein '352 patent and respiration signals as described above in the referenced Plicchi '892 and '251 patents.

FIG. **19** is a simplified schematic view of a fifth embodiment of a full Monitor/Brain and Respiration Therapy unit **500** implanted in a patient **10**. Monitor/Brain and Respiration Therapy unit **500** continuously senses and monitors cardiac, brain and respiration function of patient **10** via brain lead **18** and respiration lead **28** with integrated electrode **24** to allow detection of neurological events, the recording of data and signals pre and post event, and the delivery of therapy via brain lead **18** and phrenic nerve lead **28**. Stored diagnostic data is uplinked and evaluated by the patient's physician utilizing programmer **12** via a 2-way telemetry link **32**. An external patient activator **22** may optionally allow the patient **10**, or other care provider (not shown), to manually activate the recording of diagnostic data and delivery of therapy. Optionally, lead **28** may connect to the diaphragm to provide direct diaphragmatic stimulation. Integrated electrode **24** senses ECG signals as described above in the referenced Klein '352 patent and respiration signals as described above in the referenced Plicchi '892 and '251 patents. Monitor+Treatment (Brain+Cardiac)

FIG. **24A** is a simplified schematic view of a full Monitor/Brain and Cardiac Therapy unit **520** implanted in a patient **10**. Monitor/Brain and Cardiac Therapy unit **520** continuously senses and monitors cardiac, brain and respiration function of patient **10** via cardiac lead(s) **16** and a brain lead **18** to allow detection of neurological events, the recording of data and signals pre and post event, and the delivery of therapy via brain lead **18** and cardiac lead(s) **16**. Stored diagnostic data is uplinked and evaluated by the patient's physician utilizing programmer **12** via a 2-way telemetry link **32**. An external patient activator **22** may optionally allow the patient **10**, or other care provider (not shown), to manually activate the recording of diagnostic data and delivery of therapy.

FIG. **24B** is a simplified schematic view of a second embodiment of a full Monitor/Brain and Cardiac Therapy system consisting of a thoracically implanted Monitor/Therapy unit **521** implanted in patient **10** in combination with a cranially implanted brain Monitor/Therapy unit **26**. Monitor/Therapy unit **521** continuously senses and monitors the cardiac and respiration function of patient **10** via cardiac

lead(s) **16** to allow detection of neurological events, the recording of data and signals pre and post event, the delivery of cardiac therapy via Monitor/Therapy unit **521** and the delivery of therapy via Monitor/Therapy unit **26**. A 2-way wireless telemetry communication link **30** connects the Monitor/Therapy unit **26** and cardiac/respiration Monitor/Therapy unit **521**. The wireless communication link **30** may consist of an RF link (such as described in U.S. Pat. No. 5,683,432 "Adaptive Performance-Optimizing Communication System for Communicating with an Implantable Medical Device" to Goedeke, et al), an electromagnetic/ionic transmission (such as described in U.S. Pat. No. 4,987,897 "Body Bus Medical Device Communication System" to Funke) or acoustic transmission (such as described in U.S. Pat. No. 5,113,859 "Acoustic Body Bus Medical Device Communication System" to Funke). Monitor **26** may be constructed as substantially described in U.S. Application Publication 2004/0176817, now U.S. Pat. No. 7,212,864, issued May 1, 2007 to Walstrand et al. and entitled "Modular implantable medical device" or U.S. Pat. Nos. 5,782,891 "Implantable Ceramic Enclosure for Pacing, Neurological and Other Medical Applications in the Human Body" to Hassler, et al or 6,427,086 "Means and Method for the Intracranial Placement of a Neurostimulator" to Fischell, et al. EEG sensing and brain stimulation is accomplished by the use of integrated electrodes in the housing of monitor **26** or, alternatively, by cranially implanted leads (not shown in FIG. **24B**). Stored diagnostic data is uplinked and evaluated by the patient's physician utilizing programmer **12** via a 2-way telemetry link **32**. An external patient activator **22** may optionally allow the patient **10**, or other care provider (not shown), to manually activate the recording of diagnostic data and delivery of therapy.

FIG. **22** is a simplified schematic view of a third embodiment of a full Monitor/Brain and Cardiac Therapy unit **540** implanted cranially in a patient **10**. Monitor/Brain and Cardiac Therapy unit **540** in combination with external patient worn vest **34** continuously senses and monitors cardiac, brain and respiration function of patient **10** to allow detection of neurological events, the recording of data and signals pre and post event, and the delivery of therapy via brain lead **18** and vest **34**. Stored diagnostic data is uplinked and evaluated by the patient's physician utilizing programmer **12** via a 2-way telemetry link **32**. An external patient activator **22** may optionally allow the patient **10**, or other care provider (not shown), to manually activate the recording of diagnostic data and delivery of therapy. A 2-way wireless telemetry communication link **30** connects the monitor/therapy unit **540** and patient worn vest **34**. The wireless communication link **30** may consist of an RF link (such as described in U.S. Pat. No. 5,683,432 "Adaptive Performance-Optimizing Communication System for Communicating with an Implantable Medical Device" to Goedeke, et al), an electromagnetic/ionic transmission (such as described in U.S. Pat. No. 4,987,897 "Body Bus Medical Device Communication System" to Funke) or acoustic transmission (such as described in U.S. Pat. No. 5,113,859 "Acoustic Body Bus Medical Device Communication System" to Funke).

Monitor/Therapy unit **540** may be constructed as substantially described in U.S. Application Publication 2004/0176817, now U.S. Pat. No. 7,212,864, issued May 1, 2007 to Walstrand et al. and entitled "Modular implantable medical device" or U.S. Pat. Nos. 5,782,891 "Implantable Ceramic Enclosure for Pacing, Neurological and Other Medical Applications in the Human Body" to Hassler, et al or 6,427,086 "Means and Method for the Intracranial Placement of a Neurostimulator" to Fischell, et al. EEG sensing is accomplished

by the use of integrated electrodes in the housing of Monitor/Therapy unit **540** or, alternatively, by cranially implanted leads.

Monitor/Therapy unit **540** may warn/alert the patient **10** via an annunciator such as, but not limited to, buzzes, tones, beeps or spoken voice (as substantially described in U.S. Pat. No. 6,067,473 "Implantable Medical Device Using Audible Sound Communication to Provide Warnings" to Greeninger, et al.) via a piezo-electric transducer incorporated in the housing of monitor **26** and transmitting sound to the patient's **10** inner ear.

FIG. **23** is a simplified schematic view of a fourth embodiment of a full Monitor/Brain and Cardiac Therapy unit **560** implanted cranially in a patient **10**. Monitor/Brain and Cardiac Therapy unit **560** in combination with leadless defibrillator **36** continuously senses and monitors cardiac, brain and respiration function of patient **10** to allow detection of neurological events, the recording of data and signals pre and post event, and the delivery of therapy via brain lead **18** and defibrillator **36**. Stored diagnostic data is uplinked and evaluated by the patient's physician utilizing programmer **12** via a 2-way telemetry link **32**. An external patient activator **22** may optionally allow the patient **10**, or other care provider (not shown), to manually activate the recording of diagnostic data and delivery of therapy. A 2-way wireless telemetry communication link **30** connects the monitor/therapy unit **560** and leadless defibrillator **36**. The wireless communication link **30** may consist of an RF link (such as described in U.S. Pat. No. 5,683,432 "Adaptive Performance-Optimizing Communication System for Communicating with an Implantable Medical Device" to Goedeke, et al), an electromagnetic/ionic transmission (such as described in U.S. Pat. No. 4,987,897 "Body Bus Medical Device Communication System" to Funke) or acoustic transmission (such as described in U.S. Pat. No. 5,113,859 "Acoustic Body Bus Medical Device Communication System" to Funke).

Monitor/Therapy unit **560** may be constructed as substantially described in U.S. Application Publication 2004/0176817, now U.S. Pat. No. 7,212,864, issued May 1, 2007 to Walstrand et al. and entitled "Modular implantable medical device" or U.S. Pat. Nos. 5,782,891 "Implantable Ceramic Enclosure for Pacing, Neurological and Other Medical Applications in the Human Body" to Hassler, et al or 6,427,086 "Means and Method for the Intracranial Placement of a Neurostimulator" to Fischell, et al. EEG sensing is accomplished by the use of integrated electrodes in the housing of Monitor/Therapy unit **560** or, alternatively, by cranially implanted leads.

Monitor/Therapy unit **560** may warn/alert the patient **10** via an annunciator such as, but not limited to, buzzes, tones, beeps or spoken voice (as substantially described in U.S. Pat. No. 6,067,473 "Implantable Medical Device Using Audible Sound Communication to Provide Warnings" to Greeninger, et al.) via a piezo-electric transducer incorporated in the housing of Monitor/Therapy unit **560** and transmitting sound to the patient's **10** inner ear.

Monitor+Treatment (Brain+Respiration+Cardiac)

FIG. **25A** is a simplified schematic view of a full Monitor/Brain, Respiration and Cardiac Therapy unit **580** implanted in a patient **10**. Monitor/Brain, Respiration and Cardiac Therapy unit **580** continuously senses and monitors cardiac, brain and respiration function of patient **10** via cardiac lead(s) **16** and a brain lead **18** to allow detection of neurological events, the recording of data and signals pre and post event, and the delivery of therapy via brain lead **18**, cardiac lead(s) **16** and phrenic nerve lead **28**. Stored diagnostic data is uplinked and evaluated by the patient's physician utilizing programmer **12**

via a 2-way telemetry link **32**. An external patient activator **22** may optionally allow the patient **10**, or other care provider (not shown), to manually activate the recording of diagnostic data and delivery of therapy. Optionally, lead **28** may connect to the diaphragm to provide direct diaphragmatic stimulation.

FIG. **25B** is a simplified schematic view of a second embodiment of a full Monitor/Brain, Respiration and Cardiac Therapy system consisting of a thoracically implanted Monitor/Respiration Therapy unit **581** in combination with a cranially implanted brain Monitor/Therapy unit **26**. Monitor/Therapy unit **581** continuously senses and monitors the cardiac and respiration function of patient **10** via cardiac lead(s) **16** to allow detection of neurological events, the recording of data and signals pre and post event, the delivery of respiration therapy via phrenic nerve lead **28** and the delivery of brain stimulation via Monitor/Therapy unit **26**. A 2-way wireless telemetry communication link **30** connects the Monitor/Therapy unit **26** and cardiac/respiration monitor/therapy unit **581**. The wireless communication link **30** may consist of an RF link (such as described in U.S. Pat. No. 5,683,432 "Adaptive Performance-Optimizing Communication System for Communicating with an Implantable Medical Device" to Goedeke, et al), an electromagnetic/ionic transmission (such as described in U.S. Pat. No. 4,987,897 "Body Bus Medical Device Communication System" to Funke) or acoustic transmission (such as described in U.S. Pat. No. 5,113,859 "Acoustic Body Bus Medical Device Communication System" to Funke). Monitor **26** may be constructed as substantially described in U.S. Application Publication 2004/0176817, now U.S. Pat. No. 7,212,864, issued May 1, 2007 to Walstrand et al. and entitled "Modular implantable medical device" or U.S. Pat. Nos. 5,782,891 "Implantable Ceramic Enclosure for Pacing, Neurological and Other Medical Applications in the Human Body" to Hassler, et al or 6,427,086 "Means and Method for the Intracranial Placement of a Neurostimulator" to Fischell, et al. EEG sensing and brain stimulation is accomplished by the use of integrated electrodes in the housing of monitor **26** or, alternatively, by cranially implanted leads (not shown in FIG. **25B**). Stored diagnostic data is uplinked and evaluated by the patient's physician utilizing programmer **12** via a 2-way telemetry link **32**. An external patient activator **22** may optionally allow the patient **10**, or other care provider (not shown), to manually activate the recording of diagnostic data and delivery of therapy. Optionally, lead **28** may connect to the diaphragm to provide direct diaphragmatic stimulation.

Core Monitor Design

Turning now to FIG. **26**, there is shown a block diagram of the electronic circuitry that makes up core Monitor **100** (FIG. **1**) in accordance with one embodiment of the invention. As can be seen from FIG. **26**, Monitor **100** comprises a primary control circuit **720**. Much of the circuitry associated with primary control circuit **720** is of conventional design, in accordance, for example, with what is disclosed in U.S. Pat. No. 5,052,388 to Sivula et al, entitled "Method and Apparatus for Implementing Activity Sensing in a Pulse Generator." To the extent that certain components of Monitor **100** are purely conventional in their design and operation, such components will not be described herein in detail, as it is believed that design and implementation of such components would be a matter of routine to those of ordinary skill in the art. For example, primary control circuit **720** in FIG. **26** includes sense amplifier circuitry **724**, a crystal clock **728**, a random-access memory and read-only memory (RAM/ROM) unit **730**, a central processing unit (CPU) **732**, a MV Processor circuit **738** and a telemetry circuit **734**, all of which are well-known in the art.

Monitor **100** preferably includes internal telemetry circuit **734** so that it is capable of being programmed by means of external programmer/control unit **12** via a 2-way telemetry link **32** (shown in FIG. 1). Programmers and telemetry systems suitable for use in the practice of the present invention have been well known for many years. Known programmers typically communicate with an implanted device via a bi-directional radio-frequency telemetry link, so that the programmer can transmit control commands and operational parameter values to be received by the implanted device, and so that the implanted device can communicate diagnostic and operational data to the programmer. Programmers believed to be suitable for the purposes of practicing the present invention include the Models 9790 and CARELINK® programmers, commercially available from Medtronic, Inc., Minneapolis, Minn. Various telemetry systems for providing the necessary communications channels between an external programming unit and an implanted device have been developed and are well known in the art. Telemetry systems believed to be suitable for the purposes of practicing the present invention are disclosed, for example, in the following U.S. Patents: U.S. Pat. No. 5,127,404 to Wyborny et al. entitled "Telemetry Format for Implanted Medical Device"; U.S. Pat. No. 4,374,382 to Markowitz entitled "Marker Channel Telemetry System for a Medical Device"; and U.S. Pat. No. 4,556,063 to Thompson et al. entitled "Telemetry System for a Medical Device".

Typically, telemetry systems such as those described in the above referenced patents are employed in conjunction with an external programming/processing unit. Most commonly, telemetry systems for implantable medical devices employ a radio-frequency (RF) transmitter and receiver in the device, and a corresponding RF transmitter and receiver in the external programming unit. Within the implantable device, the transmitter and receiver utilize a wire coil as an antenna for receiving downlink telemetry signals and for radiating RF signals for uplink telemetry. The system is modeled as an air-core coupled transformer. An example of such a telemetry system is shown in the above-referenced Thompson et al. '063 patent.

In order to communicate digital data using RF telemetry, a digital encoding scheme such as is described in the above-reference Wyborny et al. '404 patent can be used. In particular, for downlink telemetry a pulse interval modulation scheme may be employed, wherein the external programmer transmits a series of short RF "bursts" or pulses in which the interval between successive pulses (e.g., the interval from the trailing edge of one pulse to the trailing edge of the next) is modulated according to the data to be transmitted. For example, a shorter interval may encode a digital "0" bit while a longer interval encodes a digital "1" bit.

For uplink telemetry, a pulse position modulation scheme may be employed to encode uplink telemetry data. For pulse position modulation, a plurality of time slots are defined in a data frame, and the presence or absence of pulses transmitted during each time slot encodes the data. For example, a sixteen-position data frame may be defined, wherein a pulse in one of the time slots represents a unique four-bit portion of data.

As depicted in FIG. 26, programming units such as the above-referenced Medtronic Models 9790 and CARELINK® programmers typically interface with the implanted device through the use of a programming head or programming paddle, a handheld unit adapted to be placed on the patient's body over the implant site of the patient's implanted device. A magnet in the programming head effects reed switch closure in the implanted device to initiate a telem-

etry session. Thereafter, uplink and downlink communication takes place between the implanted device's transmitter and receiver and a receiver and transmitter disposed within the programming head.

As previously noted, primary control circuit **720** includes central processing unit **732** which may be an off-the-shelf programmable microprocessor or microcontroller, but in the presently preferred embodiment of the invention is a custom integrated circuit. Although specific connections between CPU **732** and other components of primary control circuit **720** are not shown in FIG. 26, it will be apparent to those of ordinary skill in the art that CPU **732** functions to control the timed operation of sense amplifier circuit **724** under control of programming stored in RAM/ROM unit **730**. It is believed that those of ordinary skill in the art will be familiar with such an operative arrangement.

With continued reference to FIG. 26, crystal oscillator circuit **728**, in the presently preferred embodiment a 32,768-Hz crystal controlled oscillator, provides main timing clock signals to primary control circuit **720**.

It is to be understood that the various components of monitor **100** depicted in FIG. 26 are powered by means of a battery (not shown), which is contained within the hermetic enclosure of monitor **100**, in accordance with common practice in the art. For the sake of clarity in the figures, the battery and the connections between it and the other components of monitor **100** are not shown.

With continued reference to FIG. 26, sense amplifier **724** is coupled to monitoring elements **14** such as subcutaneous electrodes. Cardiac intrinsic signals are sensed by sense amplifier **724** as substantially described in U.S. Pat. No. 6,505,067 "System and Method for Deriving a Virtual ECG or EGM Signal" to Lee, et al. Further processing by CPU **732** allows the detection of cardiac electrical characteristics/anomalies (e.g., heart rate, heart rate variability, arrhythmias, cardiac arrest, sinus arrest and sinus tachycardia) that would be a matter of routine to those of ordinary skill in the art.

Further processing of the cardiac signal amplitudes may be used to detect respiration characteristics/anomalies (e.g., respiration rate, tidal volume, minute ventilation, and apnea) in MV Processor **738**. FIG. 27 shows the intracardiac signals **770** presented to sense amplifier **724** from monitoring elements **14**. Note the amplitude variation of cardiac signals caused by the change in thoracic cavity pressure due to respiration (i.e., inspiration and expiration). By low pass filtering the cardiac signals **770**, a signal representing minute ventilation may be obtained as depicted in waveform **772** (FIG. 27). This respiration signal may further be examined to detect respiration rate and reduced or absence of inspiration and expiration (central apnea) by CPU **732** and software resident in RAM/ROM **730**.

Upon detection of either a cardiac or respiration anomaly, CPU **732**, under control of computer executable instruction in firmware resident in RAM/ROM **730**, will initiate recording of the appropriate diagnostic information into RAM of RAM/ROM **730**, initiate a warning or alert to the patient, patient caregiver, or remote monitoring location. See flow diagram and description as described below in association with FIG. 31.

Turning now to FIG. 28, there is shown a block diagram of the electronic circuitry that makes up core Monitor **120** (FIG. 2) in accordance with another disclosed embodiment of the invention. As can be seen from FIG. 28, Monitor **120** comprises a primary control circuit **720** and a minute ventilation circuit **722**. Much of the circuitry associated with primary control circuit **720** is of conventional design, in accordance, for example, with what is disclosed in U.S. Pat. No. 5,052,388

to Sivula et al, entitled "Method and Apparatus for Implementing Activity Sensing in a Pulse Generator." To the extent that certain components of Monitor 120 are purely conventional in their design and operation, such components will not be described herein in detail, as it is believed that design and implementation of such components would be a matter of routine to those of ordinary skill in the art. For example, primary control circuit 720 in FIG. 28 includes sense amplifier circuitry 724, a crystal clock 728, a random-access memory and read-only memory (RAM/ROM) unit 730, a central processing unit (CPU) 732, and a telemetry circuit 734, all of which are well-known in the art.

Monitor 120 preferably includes internal telemetry circuit 734 so that it is capable of being programmed by means of external programmer/control unit 12 via a 2-way telemetry link 32 (shown in FIG. 2). Programmers and telemetry systems suitable for use in the practice of the present invention have been well known for many years. Known programmers typically communicate with an implanted device via a bi-directional radio-frequency telemetry link, so that the programmer can transmit control commands and operational parameter values to be received by the implanted device, and so that the implanted device can communicate diagnostic and operational data to the programmer. Programmers believed to be suitable for the purposes of practicing the present invention include the Models 9790 and CARELINK® programmers, commercially available from Medtronic, Inc., Minneapolis, Minn. Various telemetry systems for providing the necessary communications channels between an external programming unit and an implanted device have been developed and are well known in the art. Telemetry systems believed to be suitable for the purposes of practicing the present invention are disclosed, for example, in the following U.S. patents: U.S. Pat. No. 5,127,404 to Wyborny et al. entitled "Telemetry Format for Implanted Medical Device"; U.S. Pat. No. 4,374,382 to Markowitz entitled "Marker Channel Telemetry System for a Medical Device"; and U.S. Pat. No. 4,556,063 to Thompson et al. entitled "Telemetry System for a Medical Device".

Typically, telemetry systems such as those described in the above referenced patents are employed in conjunction with an external programming/processing unit. Most commonly, telemetry systems for implantable medical devices employ a radio-frequency (RF) transmitter and receiver in the device, and a corresponding RF transmitter and receiver in the external programming unit. Within the implantable device, the transmitter and receiver utilize a wire coil as an antenna for receiving downlink telemetry signals and for radiating RF signals for uplink telemetry. The system is modeled as an air-core coupled transformer. An example of such a telemetry system is shown in the above-referenced Thompson et al. '063 patent.

In order to communicate digital data using RF telemetry, a digital encoding scheme such as described in the above-reference Wyborny et al. '404 patent can be used. In particular, for downlink telemetry a pulse interval modulation scheme may be employed, wherein the external programmer transmits a series of short RF "bursts" or pulses in which the interval between successive pulses (e.g., the interval from the trailing edge of one pulse to the trailing edge of the next) is modulated according to the data to be transmitted. For example, a shorter interval may encode a digital "0" bit while a longer interval encodes a digital "1" bit.

For uplink telemetry, a pulse position modulation scheme may be employed to encode uplink telemetry data. For pulse position modulation, a plurality of time slots are defined in a data frame, and the presence or absence of pulses transmitted

during each time slot encodes the data. For example, a sixteen-position data frame may be defined, wherein a pulse in one of the time slots represents a unique four-bit portion of data.

As depicted in FIG. 28, programming units such as the above-referenced Medtronic Models 9790 and CARELINK® programmers typically interface with the implanted device through the use of a programming head or programming paddle, a handheld unit adapted to be placed on the patient's body over the implant site of the patient's implanted device. A magnet in the programming head effects reed switch closure in the implanted device to initiate a telemetry session. Thereafter, uplink and downlink communication takes place between the implanted device's transmitter and receiver and a receiver and transmitter disposed within the programming head.

With continued reference to FIG. 28, Monitor 120 is coupled to leads 16 which, when implanted, extend transversely between the implant site of Monitor 120 and the patient's heart (not shown). For the sake of clarity, the connections between leads 16 and the various components of Monitor 120 are not shown in FIG. 28, although it will be clear to those of ordinary skill in the art that, for example, leads 16 will necessarily be coupled, either directly or indirectly, to sense amplifier circuitry 724 in accordance with common practice, such that cardiac electrical signals may be conveyed to sensing circuitry 724, via leads 16. Cardiac leads 16 may consist of any typical lead configuration as is known in the art, such as, without limitation, right ventricular (RV) pacing or defibrillation leads, right atrial (RA) pacing or defibrillation leads, single pass RA/RV pacing or defibrillation leads, coronary sinus (CS) pacing or defibrillation leads, left ventricular pacing or defibrillation leads, pacing or defibrillation epicardial leads, subcutaneous defibrillation leads, unipolar or bipolar lead configurations, or any combinations of the above lead systems.

Sensed cardiac events are evaluated by CPU 732 and software stored in RAM/ROM unit 730. Cardiac anomalies detected include heart rate variability, QT variability, QT<sub>c</sub>, sinus arrest, syncope, ST segment elevation and various arrhythmias such as sinus, atrial and ventricular tachycardias.

Heart rate variability may be measured by the method and apparatus as described in U.S. Pat. No. 5,749,900 "Implantable Medical Device Responsive to Heart Rate Variability Analysis" to Schroepfel, et al and U.S. Pat. No. 6,035,233 "Implantable Medical Device Responsive to Heart Rate Variability Analysis" to Schroepfel, et al. Schroepfel '900 and '233 patents describe an implantable cardiac device that computes time intervals occurring between successive heartbeats and then derive a measurement of heart rate variability from epoch data for predetermined time periods. The Schroepfel device then compares measurement of heart rate variability with previously stored heart rate variability zones, which define normal and abnormal heart rate variability.

QT variability may be measured by the method and apparatus as described in U.S. Pat. No. 5,560,368 "Methodology for Automated QT Variability Measurement" to Berger. The Berger '368 patent utilizes a "stretchable" QT interval template started at the beginning of the QRS complex and terminating on the T-wave to determine beat-to-beat variability.

QT<sub>c</sub> may be measured by the method and apparatus as described in U.S. Pat. No. 6,721,599 "Pacemaker with Sudden Rate Drop Detection Based on QT Variations" to de Vries. The de Vries '599 patent measures QT interval real time and compares the instantaneous value to a calculated mean via a preprogrammed threshold change value.

Syncopal may be detected by the methods and apparatus as described in U.S. Pat. No. 6,721,599 "Pacemaker with Sudden Rate Drop Detection Based on QT Variations" to de Vries. The de Vries '599 patent utilizes a sudden rate change and a real time QT interval measurement compared to a QT mean to detect sudden rate drop and neurally mediated syncope.

ST segment elevation (an indicator of myocardial ischemia) may be detected by the methods and apparatus as described in U.S. Pat. No. 6,128,526 "Method for Ischemia Detection and Apparatus for Using Same" to Stadler, et al and U.S. Pat. No. 6,115,630 "Determination of Orientation of Electrocardiogram Signal in Implantable Medical devices" to Stadler, et al. The Stadler '526 and '630 patents describe a system that compares a sampled data point prior to an R-wave complex peak amplitude to multiple samples post R-wave event to detect ST segment elevation.

Arrhythmias such as sinus, atrial and ventricular tachycardias may be detected by the methods and apparatus as described in U.S. Pat. No. 5,545,186 "Prioritized Rule Based Method and Apparatus for Diagnosis and Treatment of Arrhythmias" to Olson, et al.

Sinus arrest may be detected by the methods and apparatus as described above in the Olson '186 patent.

In the presently disclosed embodiment, two leads are employed—an atrial lead 16A having atrial TIP and RING electrodes, and a ventricular lead 16V having ventricular TIP and RING electrodes. In addition, as noted above, the conductive hermetic canister of Monitor 120 serves as an indifferent electrode.

As previously noted, primary control circuit 720 includes central processing unit 732 which may be an off-the-shelf programmable microprocessor or microcontroller, but in the presently preferred embodiment of the invention is a custom integrated circuit. Although specific connections between CPU 732 and other components of primary control circuit 720 are not shown in FIG. 28, it will be apparent to those of ordinary skill in the art that CPU 732 functions to control the timed operation of sense amplifier circuit 724 under control of programming stored in RAM/ROM unit 730. It is believed that those of ordinary skill in the art will be familiar with such an operative arrangement.

With continued reference to FIG. 28, crystal oscillator circuit 728, in the presently preferred embodiment a 32,768-Hz crystal controlled oscillator, provides main timing clock signals to primary control circuit 720 and to minute ventilation circuit 722.

It is to be understood that the various components of Monitor 120 depicted in FIG. 28 are powered by means of a battery (not shown), which is contained within the hermetic enclosure of Monitor 120, in accordance with common practice in the art. For the sake of clarity in the figures, the battery and the connections between it and the other components of Monitor 120 are not shown.

As shown in FIG. 28, primary control circuit 720 is coupled to minute ventilation circuit 722 by means of multiple signal lines, designated collectively as 738 in FIG. 28. An I/O interface 740 in primary control circuit 720 and a corresponding I/O interface 742 in minute ventilation circuit 722, coordinate the transmission of signals between the two units via control lines 738.

Minute ventilation circuit 722 measures changes in transthoracic impedance, which has been shown to be proportional to minute ventilation. Minute ventilation is the product of tidal volume and respiration rate, and as such is a physiologic indicator of changes in metabolic demand.

Monitor 120, in accordance with the presently disclosed embodiment of the invention, measures transthoracic impedance using a bipolar lead 16 and a tripolar measurement system. As will be hereinafter described in greater detail, minute ventilation circuit 722 delivers 30-microSec biphasic current excitation pulses of 1-mA (peak-to-peak) between a RING electrode of bipolar lead 16 and the conductive canister of monitor 120, functioning as an indifferent electrode CASE, at a rate of 16-Hz. The resulting voltage is then measured between a TIP electrode of lead 16 and the monitor 120 CASE electrode. Such impedance measurement may be programmed to take place in either the atrium or ventricle of the patient's heart.

The impedance signal derived by minute ventilation circuit 722 has three main components: a DC offset voltage; a cardiac component resulting from the heart's function; and a respiratory component. The frequencies of the cardiac and respiratory components are assumed to be identical to their physiologic origin. Since the respiratory component of the impedance signal derived by minute ventilation circuit 722 is of primary interest for this aspect of the present invention, the impedance signal is subjected to filtering in minute ventilation low-pass filter (MV LPF) 750 having a passband of 0.05- to 0.8-Hz (corresponding to 3-48 breaths per minute) to remove the DC and cardiac components.

With continuing reference to FIG. 28, minute ventilation circuit 722 includes a Lead Interface circuit 744 which is essentially a multiplexer that functions to selectively couple and decouple minute ventilation circuit 722 to the VTIP, VRING, ATIP, ARING, and CASE electrodes, as will be hereinafter described in greater detail.

Coupled to lead interface circuit 744 is a minute ventilation (MV) Excitation circuit 746 which functions to deliver the biphasic constant-current pulses between various combinations of lead electrodes (VTIP, VRING, etc.) for the purpose of measuring cardiac impedance. In particular, MV Excitation circuit 746 delivers biphasic excitation pulses (at a rate of 16-Hz between the ventricular ring electrode VRING and the pacemaker canister CASE) of the type delivered in accordance with the method and apparatus described in U.S. Pat. No. 5,271,395 "Method and Apparatus for Rate Responsive Cardiac Pacing" to Wahlstrand et al.

To measure cardiac impedance, minute ventilation circuit 722 monitors the voltage differential present between pairs of electrodes as excitation pulses are being injected as described above. Again, the electrodes from which voltage differentials are monitored will vary depending upon whether atrial or ventricular measurements are being made. In one embodiment of the invention, the same electrodes (i.e., VRING and CASE for ventricular, ARING and CASE for atrial) are used for both delivery of excitation pulses and voltage differential monitoring. It is contemplated, however, that the electrode combinations for excitation and measurement may be among the programmable settings, which may be altered post-implant with the programming system.

With continued reference to FIG. 28, the 16-Hz sampled output voltages from ZMEAS PREAMP circuit 748 are presented to the minute ventilation low-pass filter circuit MV LPF 750, which has a passband of 0.05-0.8 Hz in the presently preferred embodiment of the invention. Again, it is believed that the design and implementation of MV LPF circuit 750 would be a matter of routine engineering to those of ordinary skill in the art. The output from MV LPF circuit 750 is a voltage waveform whose level at any given time is directly proportional to cardiac impedance measured between the selected electrodes. Thus, the MV LPF output signal will be referred to herein as an impedance waveform.

MV Calculation **752** analyzes the impedance waveform to determine/detect respiration rate, tidal volume, minute ventilation and presence of apnea.

The circuit of FIG. **28** may additionally monitor pulmonary edema by measuring the DC impedance between the distal electrodes of cardiac leads **16** and the case of core monitor **120**. Measurement technique may be as substantially described in U.S. Pat. No. 6,512,949 "Implantable Medical Device for Measuring Time Varying Physiologic Conditions Especially Edema and for Responding Thereto" by Combs, et al.

Upon detection of a cardiac or respiration anomaly, CPU **732**, under control of firmware resident in RAM/ROM **730**, will initiate recording of the appropriate diagnostic information into RAM of RAM/ROM **730**, initiate a warning or alert to the patient, patient caregiver, or remote monitoring location. See flow diagram and description as described below in association with FIG. **31**.

Turning now to FIG. **29**, there is shown a block diagram of the electronic circuitry that makes up core Monitor **140** with sensor stub **20** (FIG. **3**) in accordance with another disclosed embodiment of the invention. As can be seen from FIG. **29**, Monitor **140** comprises a primary control circuit **720** and a minute ventilation circuit **722**, the function of which has been described in detail above in conjunction with the system of FIG. **28**. Monitor **140** measures thoracic impedance from the case of monitor **140** to the distal end of a sensor stub lead **20** (a subcutaneously implanted sensor lead) via an impedance/voltage converter using a sampling frequency of approximately 16 Hz as substantially described in U.S. Pat. No. 4,596,251 "Minute Ventilation Dependant Rate Responsive Pacer" to Plicchi, et al. Respiration parameters are evaluated by CPU **732** and software resident in RAM/ROM **730**.

Cardiac signals are sensed by sense amplifier **724** and evaluated by CPU **732** and software resident in RAM/ROM **730**.

Upon detection of either/or a cardiac or respiration anomaly, CPU **732**, under control of firmware resident in RAM/ROM **730**, will initiate recording of the appropriate diagnostic information into RAM of RAM/ROM **730**, initiate a warning or alert to the patient, patient caregiver, or remote monitoring location. See flow diagram and description as described below in association with FIG. **31**.

Turning now to FIG. **30**, there is shown a block diagram of the electronic circuitry that makes up external patch core Monitor **160** (FIG. **4**) in accordance with another disclosed embodiment of the invention. As can be seen from FIG. **30**, Monitor **160** comprises a primary control circuit **720** and a minute ventilation circuit **722**, the function of which has been described in detail above in conjunction with the system of FIG. **28**. Intrinsic cardiac signals are sensed by electrodes **161** affixed to the patient's skin, amplified by amplifier **724** and processed by CPU **732** and software program resident in RAM/ROM **730**. Cardiac anomalies are detected such as heart rate variability, QT variability, QT<sub>c</sub>, sinus arrest, and various arrhythmias such as sinus, atrial and ventricular tachycardias. Respiration sensing is accomplished by low pass filtering the sensed and amplified intrinsic cardiac signals as shown in FIG. **27**. Respiration anomalies (such as reduced or cessation of tidal volume and apnea) are evaluated and detected by CPU **732** and software resident in RAM/ROM **730**.

Upon detection of either/or a cardiac or respiration anomaly, CPU **732**, under control of firmware resident in RAM/ROM **730**, will initiate recording of the appropriate diagnostic information into RAM of RAM/ROM **730**, initiate a warning or alert to the patient, patient caregiver, or remote

monitoring location. See flow diagram and description as described below in association with FIG. **31**.

FIG. **31** is a flow diagram **800** showing operation of a core Monitor sensing/monitoring cardiac and respiration parameters for the detection of neurological events as shown and described in embodiments in FIG. **1-4** above. Beginning at block **802**, the interval between sensed cardiac signals are measured. At block **804**, a rate stability measurement is made on each cardiac interval utilizing a heart rate average from block **806**. At block **808**, a rate stable decision is made based upon preprogrammed parameters. If YES, the flow diagram returns to the HR Measurement block **802**. If NO, the rate stability information is provided to Format Diagnostic Data block **812**.

At block **816**, thoracic impedance is continuously measured in a sampling operation. At block **818**, a MV and respiration rate calculation is made. At block **822**, a pulmonary apnea decision is made based upon preprogrammed criteria. If NO, the flow diagram returns to MV Measurement block **816**. If YES, the occurrence of apnea and MV information is provided to Format Diagnostic Data block **812**. Format Diagnostic Data block **812** formats the data from the cardiac and respiration monitoring channels, adds a time stamp (i.e., date and time) and provides the data to block **814** where the data is stored in RAM, SRAM or MRAM memory for later retrieval by a clinician via telemetry. Optionally, block **812** may add examples of intrinsic ECG or respiration signals recorded during a sensed episode/seizure. Additionally, optionally, block **815** may initiate a warning or alert to the patient, patient caregiver, or remote monitoring location (as described in U.S. Pat. No. 5,752,976 "World Wide Patient Location and Data Telemetry System for Implantable Medical Devices" to Duffin, et al.

Full Monitor Design

FIG. **32** is a block diagram of the electronic circuitry that makes up full Monitor **200** (FIG. **5**) in accordance with the presently disclosed alternative embodiment of the invention. As can be seen from FIG. **32**, Monitor **200** includes a primary control circuit **720** that is described herein above in conjunction with FIG. **26**. In addition the full monitor of FIG. **30** also includes an amplifier **725** to amplify and sense EEG signals from a cranially implanted lead **18**. The CPU **732**, in conjunction with a software program resident in RAM/ROM **730**, evaluates the information from the sensed cardiac, respiration and EEG signals, detects the onset of cerebral, cardiac or respiratory anomalies, may perform one or more algorithms or methods as described in this specification (such as determination of concordance between EEG and cardiac or respiratory signals, comparison of heart rates associated with certain neurological event time periods, etc.), formats and stores diagnostic data for later retrieval by the patient's clinician and, optionally, may warn or alert the patient, patient caregiver or remote monitoring location. See flow diagram and description below in association with FIG. **37**.

FIG. **33** is a block diagram of the electronic circuitry that makes up full Monitor **220** with brain **18** and cardiac **16** leads (FIG. **6**) in accordance with the presently disclosed alternative embodiment of the invention. As can be seen from FIG. **33**, Monitor **220** comprises a primary control circuit **720** and MV circuit **722** that are described herein above in conjunction with FIG. **28**. In addition, the full Monitor **220** of FIG. **33** also includes an amplifier **725** to amplify and sense EEG signals from a cranially implanted lead **18**. The CPU **732**, in conjunction with a software program resident in RAM/ROM **730**, integrates the information from the sensed cardiac, respiration and EEG signals, detects the onset of cerebral, cardiac or respiratory anomalies, formats and stores diagnostic data for

later retrieval by the patient's clinician and, optionally, may warn or alert the patient, patient caregiver or remote monitoring location. See flow diagram and description as described below in association with FIG. 37.

FIG. 34 is a block diagram of the electronic circuitry that makes up full Monitor 240 with a brain lead 18 and sensor stub 20 (FIG. 7) in accordance with the presently disclosed alternative embodiment of the invention. As can be seen from FIG. 34, Monitor 240 comprises a primary control circuit 720 and MV circuit 722 that are described herein above in conjunction with FIG. 28. In addition, the full Monitor 240 of FIG. 34 also includes an amplifier 725 to amplify and sense EEG signals from a cranially implanted lead 18. The CPU 732, in conjunction with a software program resident in RAM/ROM 730, integrates the information from the sensed cardiac, respiration and EEG signals, detects the onset of cerebral, cardiac or respiratory anomalies, formats and stores diagnostic data for later retrieval by the patient's clinician and, optionally, may warn or alert the patient, patient caregiver or remote monitoring location. See flow diagram and description as described below in association with FIG. 37.

FIG. 35 is a block diagram of the electronic circuitry that makes up external patch 160/full Monitor 260 with a brain lead 18 (FIG. 8) in accordance with the presently disclosed alternative embodiment of the invention. As can be seen from FIG. 35, Monitor 260 comprises a primary control circuit 720 and external patch comprises a cardiac/MV (minute ventilation) circuit 160, the functions of which have been described in detail above in conjunction with the system of FIG. 28. Intrinsic cardiac signals are sensed by electrodes affixed to the patient's skin, amplified by amplifier 724, sent to primary control circuit 720 and processed by CPU 732 and software program resident in RAM/ROM 730. Cardiac anomalies are detected such as heart rate variability, QT variability, QT<sub>c</sub>, sinus arrest, and various arrhythmias such as sinus, atrial and ventricular tachycardias. Respiration sensing is accomplished by low pass filtering the sensed and amplified intrinsic cardiac signals as shown in FIG. 27 or, alternatively, by using the MV/Z measurement circuitry of external patch 160 as described above in connection with FIG. 28. Respiration anomalies (such as reduced or cessation of tidal volume and apnea) are evaluated and detected by CPU 732 and software resident in RAM/ROM 730.

The CPU 732, in conjunction with a software program resident in RAM/ROM 730, integrates the information from the sensed cardiac, respiration and EEG signals, detects the onset of cerebral, cardiac or respiratory anomalies, formats and stores diagnostic data for later retrieval by the patient's clinician and, optionally, may warn or alert the patient, patient caregiver or remote monitoring location. See flow diagram and description as described below in association with FIG. 37.

The circuitry and function of the device 240 shown in FIG. 34 and described herein above may also be used for the full Monitor 280 with integrated electrode 24 brain lead 18 (FIG. 9). As described above in association with core Monitor 240, thoracic impedance via impedance/voltage converter as measured from the case of monitor 240 to the sensor stub 20 using a sampling frequency of approximately 16 Hz as substantially described in U.S. Pat. No. 4,596,251 "Minute Ventilation Dependant Rate Responsive Pacer" to Plicchi, et al. The Monitor 280 of this alternative embodiment utilizes the same circuitry of Monitor 240 but connected to the integrated electrode 24 on brain lead 18 instead of the sensor stub of Monitor 240.

Upon detection of either/or a cardiac or respiration anomaly, CPU 732, under control of firmware resident in

RAM/ROM 730, will initiate recording of the appropriate diagnostic information into RAM of RAM/ROM 730, initiate a warning or alert to the patient, patient caregiver, or remote monitoring location. See flow diagram and description as described below in association with FIG. 37.

FIG. 36 is a block diagram of the electronic circuitry that makes up full Monitor 26 (FIG. 10) in accordance with the presently disclosed alternative embodiment of the invention. As can be seen from FIG. 32, Monitor 26 comprises a primary control circuit 720 whose function is described herein above in conjunction with FIG. 26. In addition the full Monitor 26 of FIG. 32 also includes an EEG amplifier 725 to amplify and sense EEG signals from a cranially implanted lead 18 or, alternatively, device mounted electrodes. Additionally, Sensor Interface 727 powers up, amplifies and senses the cardiac and respiratory signals from anyone or more of the following cranially implanted sensors. ECG sensing in the cranium may be accomplished by leadless ECG sensing as described in the above Brabec '940, Ceballos '915 and Lee '067 referenced patents. Alternatively, cardiac rate and asystole may be inferred from a dP/dt signal described above in the Anderson '813 patent; an acoustic signal described above in the Kieval '177 patent; an O<sub>2</sub>sat signal described above in Moore '701 patent; a dT/dt signal described above in the Weijand '244 patent; a flow signal described above in the Olson '009; a strain gauge signal described above in the Bowman '759 patent; and a blood parameter sensor (such as oxygen, pulse or flow) located on a V-shaped lead described in the Taepke '318 patent.

The CPU 732, in conjunction with a software program resident in RAM/ROM 730, integrates the information from the sensed cardiac, respiration and EEG signals, detects the onset of cerebral, cardiac or respiratory anomalies, formats and stores diagnostic data for later retrieval by the patient's clinician and, optionally, may warn or alert the patient, patient caregiver or remote monitoring location. See flow diagram and description as described below in association with FIG. 37.

FIG. 37 is a flow diagram 840 showing operation of a full monitor sensing and monitoring cardiac, respiration and electroencephalogram parameters for the detection of neurological events as shown and described in embodiments in FIG. 5-10 above. Beginning at block 802, the interval between sensed cardiac signals are measured. At block 804, a rate stability measurement is made on each cardiac interval utilizing a heart rate average from block 806. At block 808, a rate stable decision is made based upon preprogrammed parameters. If YES, the flow diagram returns to the HR Measurement block 802. If NO, the rate stability information is provided to Format Diagnostic Data block 812.

At block 816, thoracic impedance is continuously measured in a sampling operation. At block 818, a MV and respiration rate calculation is made. At block 822, a pulmonary apnea decision is made based upon preprogrammed criteria. If NO, the flow diagram returns to MV Measurement block 816. If YES, the occurrence of apnea and MV information is provided to Format Diagnostic Data block 812.

At block 824, the electroencephalogram is sensed and measured. An EEG seizure determination is performed at block 826 as described in U.S. Application Publication 2004/0138536, now U.S. Pat. No. 7,280,867, issued Oct. 9, 2007 to Frei et al. and entitled "Clustering of Recorded Patient Neurological Activity to Determine Length of a Neurological Event", incorporated herein by reference. At block 828, a seizure cluster episode is determined. If NO, the flow diagram returns to EEG Measurement block 824. If YES, the occurrence of a seizure cluster is provided to Format Diagnostic

Data block **812**. Format Diagnostic Data block **812** formats the data from the cardiac, respiration and EEG monitoring channels, adds a time stamp (i.e., date and time) and provides the data to block **814** where the data is stored in RAM memory for later retrieval by a clinician via telemetry. Optionally, block **812** may add examples of intrinsic ECG, respiration or EEG signals recorded during a sensed episode/seizure. Additionally, optionally, block **815** may initiate a warning or alert to the patient, patient caregiver, or remote monitoring location (as described in U.S. Pat. No. 5,752,976 “World Wide Patient Location and Data Telemetry System for Implantable Medical Devices” to Duffin, et al.

FIG. **38** is a diagram **850** of exemplary physiologic data from a patient **10** with a full monitor as described herein above showing an EEG signal **852** and an ECG signal **854**. A first epileptic seizure is shown at **856** (pre-stimulation segment **851**, stimulation segment **853** and post-stimulation segment **855**) and detected at **864** and a second seizure is shown at **858** (pre-stimulation segment **857**, stimulation segment **859** and post-stimulation segment **861**) and detected at **866** by the full monitor. The ECG signal **854** shows a first arrhythmic episode at **860** and detected at **868** and a second arrhythmic episode at **862** and detected at **870** by the full monitor. Note that the first epileptic seizure **864** and arrhythmic episode **868** are co-incident and “matched”. Note that in the diagram **850** arrhythmic episode **870** and seizure episode **866** are not co-incident and are “unmatched”.

Segmenting a Cardiac Signal According to Brain Detection Results.

One embodiment of the inventive system provides an automated method of processing cardiac and/or respiratory signals in a full monitoring device (brain-heart, brain-respiratory or brain, heart and respiratory) for a nervous system disorder, to screen for cardiac abnormalities/heart rate changes and respiratory abnormalities during or within a specified time period of a neurological event. This embodiment medical device system and method may report a patient’s heart or pulmonary condition for each neurological event detected in the brain signal.

In a monitoring device for epilepsy, brain signals are monitored/processed with a seizure detection algorithm; the cardiac and respiratory signals are passively recorded during the brain signal processing. When a seizure has been detected in the brain signal data stream, a recording containing a montage of brain, cardiac and respiratory signals is created. The signals in the recording are then post-processed to evaluate the patient’s heart and pulmonary condition. A description of the post-processed design is shown in FIG. **39**.

FIG. **39** shows one embodiment process **750** for identifying ECG and respiratory abnormalities recorded during detected seizures. At block **751**, the full monitor monitors EEG and ECG or respiratory signals. At block **752**, the monitor detects seizures in EEG signals. At block **753**, seizure detection triggers recording and retention of EEG, ECG and respiratory signals. After uplinking to a programmer, the ECG/respiratory signals are post-processed. At this point one or more processors may identify an event portion, pre-event portion and post-event portion of the cardiac signal based on the starting point and the ending point of the brain event time period. The event portion of the cardiac signal may correspond in time exactly to the brain event time period such as an stimulation period, or it may be different but computed based on the starting and ending points of the brain event time period. The pre-event portion of the cardiac signal may be everything before the event time period or it may be a period beginning a programmable period of time before the event time period to the beginning of the event time period. Like-

wise, the post-event time period may be everything after an event time period or it may be a period beginning at the end of the event time period and extending to a programmable period of time after the end of the event time period. For the seizure example, at block **755**, ECG and respiratory signals are segmented into (a) pre-stimulation, (b) stimulation, and (c) post-stimulation periods based upon the determined starting and ending points of the neurological event in the brain signal. The stimulation periods are automatically derived from a seizure-detection algorithm operating on the EEG signals. For example, the beginning of the stimulation period may be time-marked to detection cluster onset; the end of the stimulation period by detection cluster offset (as described in U.S. Application Publication 2004/0138536, now U.S. Pat. No. 7,280,867, issued Oct. 9, 2007 to Frei et al. and entitled “Clustering of Recorded Patient Neurological Activity to Determine Length of a Neurological Event”, incorporated herein by reference in its entirety). The durations of the pre-stimulation and post-stimulation periods are programmable. It may be desirable to program the pre-stimulation period for purposes of a cardiac baseline or respiratory baseline as ending some period of time before or after the true stimulation period as determined by the EEG detector. In this way a better baseline may be obtained that is not distorted by changes in cardiac or respiratory activity near in time to the neurological event.

At block **756**, the loop-recorded data is screened for abnormalities. After the ECG and respiratory signals are segmented, the different intervals of ECG and respiratory data are separately processed to determine metrics associated with those signals. The term metric is used interchangeably herein with the term indices. These metrics may assist in detecting events or determining features or other activity reflected in those signals. Exemplary cardiac metrics that may be computed include indices of heart rate (HR) (i.e., mean, median, max, std. dev., etc.) or indications of abnormal heart activity such as an arrhythmia which are displayed in the physician programmer for each detected event. Exemplary respiratory metrics that may be computed include minute ventilation, respiration rate, apnea, or edema, which are displayed in the physician programmer for each detected event. Metrics from different segmented intervals or time periods of the cardiac or respiratory signal may be compared to one another. For example, to monitor changes in cardiovascular and pulmonary function that may arise from or cause seizures, percentage of change between indices/metrics may be calculated. For example, to indicate magnitude of change in heart rate from a baseline to seizure state, the percentage of change between the pre-stimulation (baseline) and stimulation (seizure) periods is computed/displayed.

$$\% \text{ Chg. Detect Onset} = (\text{Stimulation HR indices} - \text{Base HR indices}) / \text{Base HR indices}$$

Comparison between the post-stimulation and baseline periods is also performed to evaluate if and when a return to baseline is achieved.

$$\% \text{ Chg. Detect End} = (\text{Post-Stimulation HR indices} - \text{Base HR indices}) / \text{Base HR indices}$$

During processing, the time at which the post-stimulation heart rate returns to baseline, relative to the end of the stimulation period, is identified. The physician may choose to increase the duration of the post-stimulation period if, during detected seizures, the patient’s HR indices do not consistently return to baseline levels.

At block **757**, detection times for arrhythmic and respiratory anomalies are determined. The ECG and respiratory

signals are further processed, via an arrhythmia/abnormality detection algorithm, to identify ECG and respiratory abnormalities (bradycardia, tachycardia, asystole, ST segment depression, QTc prolongation, apnea, edema, etc.). Such events may occur in different periods of data, and cross stimulation boundaries (e.g., a tachy event may begin prior to seizure onset, and continue well after seizure termination, resulting in a detection that includes all intervals of data). Thus, during screening the entire ECG and respiration signals in the loop recording data is processed in a single step, without segmentation. The start and end times for each identified arrhythmia/abnormality in the loop recording data is stored and later retrieved for analysis.

The physician may further run a matching test (EEG detections versus ECG or respiratory detections) at block 758. The matching test is run to compare the EEG detections and ECG/respiratory detections in the loop recording data. The matching test reports whether each ECG/respiratory abnormality is coincident with (i.e., matched), or is temporally separated from, the detected seizure (i.e., unmatched). In the case of a match, the time difference between EEG detection onset and ECG/respiratory detection onset is computed.

At block 759, the matching test results are evaluated to determine if the seizure is associated with an arrhythmia or respiratory anomaly. At block 760, additional seizures are determined. If NO, block 761 reports results of ECG/respiratory screening procedures for each seizure. At block 760, if the result is YES the flow diagram returns to block 752.

ECG/respiratory post-processing may occur in the implantable device, after the loop recorded data has been stored to memory. Alternatively, the post-processing may occur on loop-recorded data transmitted to an external wearable device or physician programmer or other computer.

In another embodiment of cardiac signal segmentation it may be desirable to record the amount of time it takes a metric of the cardiac signal to return to some baseline metric after a change in the brain signal has been discovered. For example, the system may determine a first metric such as heart rate associated with a pre-event portion of the cardiac signal. The first metric is the baseline. The system then determines a second metric for the post-event portion and determines whether it meets predetermined criteria about its relationship to the first metric. The predetermined criteria may be any way of determining or estimating whether the second metric (e.g., heart rate after the seizure) has reached or is close enough to the first metric (e.g., the heart rate before the seizure). For example, the predetermined criteria may simply be to determine whether the second metric equals the first metric. Another example of predetermined criteria may be a determination of whether the second metric is within a specified range of the first metric. In another exemplary embodiment, the predetermined criteria may evaluate whether successive metrics cross from being greater than the first metric to less than the first metric or vice versa. Once the value of the first metric is crossed the predetermined criteria are met. If the predetermined criteria are met, a second metric time is recorded or otherwise transmitted. The second metric time means some time value related to the amount of time from the at least one reference point to the occurrence of the second portion. For example, in one embodiment, the second metric time is the amount of time from the ending point of the seizure to the point in time when the heart rate has returned to its pre-stimulation level. In this way the clinician may learn for each event the amount of time it took a particular metric of the patient's cardiac signal to return to baseline. In one embodiment the second portion may be a short or very short period of time such as, for example, 10 seconds, 5 seconds, 2 seconds,

1 second, or less than 1 second, or even on a sample by sample basis (e.g., determine a new metric each time there is a heart beat). By using a short second portion, successive portions may be evaluated until the metric associated with the portions meets the predetermined criteria.

Determination of Improvements in Neurological Event Detection Using Cardiac or Respiratory Input

Another embodiment of the invention is a medical device system and method for determining whether cardiac or respiratory signals may be used to improve neurological event detection. This medical device system includes a brain monitoring element (e.g., lead 18, external electrode), a cardiac monitoring element (e.g., lead 16, sensor stub 20, sensor 14, integrated electrode 24, external electrode, etc.) or respiratory monitoring element (e.g., lead 16, sensor stub 20, sensor 14, integrated electrode 24, external electrode, etc.) and a processor (e.g., CPU 732 or any other processor or combination of processors implanted or external). This determination of whether cardiac or respiratory signals may be used to improve neurological event detection may be very beneficial to understanding a patient's condition and that in turn is helpful to determining appropriate treatment or prevention options. The medical device system may include the ability to determine relationships between brain and heart only, brain and respiratory only, or both. Once these relationships are better understood, they may be utilized to make decisions about enabling the use of cardiac signals or cardiac detections or respiratory signals or respiratory detections in the monitoring or treatment of the neurological disorder. Note that this medical device system and method may be performed by many different types of hardware embodiments including the example hardware embodiments provided in this specification as well as in an external computer or programmer. The executable instructions executed by a processor may be stored in any computer readable medium such as, for example only, RAM 730.

The determination of improvements in neurological event detection using cardiac or respiratory input includes determination of concordance between brain and cardiac signals or between brain and respiratory signals, determination of detection latency, and the false positive rate in the cardiac or respiratory signal relative to a neurological event detected in the brain signal.

An example of the usefulness of this determination is provided here. If it is determined that a patient with epilepsy has improvement in neurological event detection based on a cardiac signal it may be desirable to enable the use of a cardiac activity detection algorithm to trigger application of therapy to the brain. Another example of the benefit of concordance information is that a high concordance between brain and heart (including perhaps concordance with a particular type of cardiac event) for an individual with epilepsy, may mean that the patient is more susceptible to SUDEP. Perhaps steps can be taken such as use or implantation of a heart assist device such as a pacemaker or defibrillator for this patient to reduce the likelihood of death. There are of course many other examples of situations that may be discovered by operation of this concordance system and method that result in better health care.

The medical device system with concordance capability may include a brain monitoring element 18 (e.g., EEG lead with one or more electrodes) for sensing activity of the brain and outputting a brain signal, and a cardiac or respiratory monitoring element 14 (e.g., electrodes or other sensors) or both, for sensing a cardiac or respiratory activity and outputting a cardiac or respiratory signal, and a processor. The processor is configured to receive the brain signal and one or

more of the cardiac and respiratory signals and to compare the brain signal and one of the cardiac or respiratory signals to each other.

Comparison of the brain and cardiac signals to each other may take many different forms. In one embodiment, the processor is configured to obtain information identifying one or more neurological events in the brain signal, and to also obtain information identifying one or more cardiac events in the cardiac signal. "Obtain" means 1) automatically generating the information by executing an algorithm that evaluates the signal, or 2) receiving the information from a user such as a physician reviewing the brain and cardiac signals (this second aspect of obtain is hereinafter referred to as "manual identification of events"). The algorithm or physician may create or generate various features of the neurological event such as a determination of when the event begins and ends and hence a duration of the event. For example automatic generation of the information may be performed by a seizure detection algorithm such as described in U.S. Application Publication 2004/0138536, now U.S. Pat. No. 7,280,867, issued Oct. 9, 2007 to Frei et al. and entitled "Clustering of Recorded Patient Neurological Activity to Determine Length of a Neurological Event". Likewise in the case of a cardiac signal, any algorithm that evaluates a cardiac signal and outputs information about cardiac activity or abnormalities would be an automatic generation of the information. Some examples are presented above in the discussion of the core monitor. An example of a manual identification of an event includes a physician indicating to a physician programmer the temporal location of a neurological event and also indicating the temporal location of cardiac or respiratory events. This temporal location of an event may include marking of the beginning and end of the event.

In the case of manual identification of an event, the medical device system may include a user interface (for example, on a programmer or computer), for display of the brain, cardiac and respiration signals. The user, such as a physician, may mark events on the programmer. For example, the physician could mark the location by clicking a cursor over the location on the monitor. In another example, the physician could mark a location with a stylus on a touch sensitive screen. The physician markings may include marks that indicate the beginning and the end of an event.

In a more specific embodiment, the comparison of the brain signal to the cardiac or respiration signal includes for each neurological event, determining whether the neurological event is within a specified time period of one of the one or more cardiac or respiratory events, and for each of the one or more cardiac or respiratory events determining whether the cardiac or respiratory event is within a specified time period of one of the one or more neurological events. Two events are "within a specified time period" of each other if the two events are overlapping in time or the amount of time between two reference points of the two events is less than a time period that is previously determined and set in the device or that has been programmed or may be programmed into the device. Reference points of an event are some measure or indication of the temporal position of the event. For example, the two reference points may be the end of the first of the events to end and the beginning of the other event. Other reference points may be used such as, but not limited to, the midpoints of each of the events. An example of a specified time period that could be programmed into the device is 10 seconds. So in this example, the neurological event and the cardiac event would be within the specified time period of each other if a chosen reference point for the cardiac event (e.g., end of the cardiac

event) was within 10 seconds of a chosen reference point (e.g., beginning of the neurological event) for the neurological event.

The comparison of brain signal to cardiac signal may include the following: determining the number of neurological events that are matched with a cardiac event (i.e., within a specified time period of a cardiac event); determining the number of neurological events that are not matched with a cardiac event (i.e., not within the specified time period of a cardiac event); and determining the number of cardiac events that are not within the specified time period of a neurological event (the false positive rate in the ECG signal). The same steps may be applied in the case of comparison of a brain signal to a respiratory signal.

Furthermore for matched events (events that are within the specified time period of each other), the processor may determine the temporal relationship of the neurological event and the matched cardiac event or between the neurological event and the matched respiratory event. Because matched events may overlap or they may not overlap, the temporal relationship may be defined or described in many different ways. One embodiment of determining the temporal relationship is determining the temporal order (which event is first to occur) of the matched events. In order to determine the temporal order between two events, a reference point must be determined. As mentioned earlier the reference point may be the end, start or midpoint of an event, or the reference point may be computed in some other way. In general a reference point indicates some temporal information about the event. The reference points may then be compared to determine which occurred first. The event associated with the first to occur reference point is then the first to occur event.

In another embodiment of comparing the brain signal to a cardiac or respiratory signal, the processor is configured to compute a rate of concordance between the neurological events and the cardiac or respiratory events. In this embodiment, the processor is configured to categorize the neurological event as cardiac matched when there is a cardiac event within a specified time period of the neurological event. The processor computes the rate of concordance between the neurological events and the cardiac events based on the number of cardiac matched events and the number of neurological events. For example, the processor may compute the rate of concordance by calculating the number of cardiac matched events divided by the number of neurological events. The more matches the greater the concordance.

In another embodiment the processor is further configured to perform the following: dividing the neurological event into at least two segments (portions); and assigning the cardiac event to one or more of the segments according to when the cardiac event occurred relative to the segments. For example, if the neurological event is a seizure, then there may be three segments: a pre-stimulation segment, an stimulation segment, and a post stimulation segment. Various methods may be used to assign a cardiac event to one of these segments. For example, an algorithm executed by the processor (e.g., any of the processors of the many hardware embodiments in this application such as CPU 732, or a processor in a programmer or other computer external to the body) may determine when the cardiac event started relative to the three segments and assign the cardiac event to the segment in which it started. Of course other methods, more complex or simple may be used to make this assignment.

The ECG algorithm may be automatically enabled/disabled for use in monitoring or treatment (as described herein below) if concordance, detection latency and false positive rates meet selected and programmable criteria, indicating an

improvement in neurological event detection performance. Alternatively, the patient's clinician may choose to review matching results and manually enable/disable the ECG detector based on information provided. For example, detection of a cardiac event may result in turning a neurostimulator or drug delivery device on to prevent the onset of a seizure. Alternatively, detection of a cardiac event may result in modification of therapy parameters. In another alternative, the ECG detector may be enabled for purposes of recording ECG, EEG or some other data.

In the embodiment that includes therapeutic output, the medical device system further includes a neurological therapy delivery module configured to provide a therapeutic output to treat a neurological disorder when the cardiac event detection algorithm detects a cardiac event. A neurological therapy delivery module may be any module capable of delivering a therapy to the patient to treat a neurological disorder. For example, but not limited to, a neurological therapy delivery module may be an electrical stimulator (e.g., stimulator **729**), drug delivery device, therapeutic patch, brain cooling module.

Depending on the individual patient, and depending on the particular neurological disorder of concern, there may be different levels of concordance between different types of cardiac events and the neurological events. Therefore, in another embodiment, the processor is further configured to obtain information categorizing each cardiac event as one or more of two or more types of cardiac events. Types of cardiac events are known by different signals or aspects of signals coming from the heart. Examples of different types of cardiac events include: tachyarrhythmia, ST segment elevation, bradycardia, asystole. In this embodiment, the processor may then determine concordance between each type of cardiac event or subset of cardiac events and neurological events. One embodiment of such determination is a processor configured to categorize each neurological event as first type cardiac matched when there is a first type cardiac event within a specified time period of the neurological event. The processor further categorizes the neurological event as second type cardiac matched when there is a second type cardiac event within a specified time period of the neurological event. The processor further computes a first rate of concordance between the neurological events and the first type cardiac events based on the number of first type cardiac matched events and the number of neurological events. The processor also computes a second rate of concordance between the neurological events and the second type cardiac events based on the number of second type cardiac matched events and the number of neurological events. This computation of rate of concordance may be performed as many times as there are types of cardiac events. The categorization of events as well as the various computed rates of concordance may be stored in memory.

In the embodiment allowing for computation of specific type of cardiac event rates of concordance, the medical device system may further include the capability to enable the use of detection of a particular type of cardiac event to affect the provision of therapy to the patient for the neurological disorder. For example, if it is determined that a high rate of concordance exists between tachyarrhythmia and seizure, the enablement of cardiac detection for affecting seizure therapy may be limited to the detection of tachyarrhythmia. In this case the seizure therapy will not be affected by other types of cardiac events.

It is noted that the medical device system may be external to the patient's body, implanted or some combination. The processor itself may be either external or implanted. For

example, the processor may be in a handheld unit such as a programmer, or the processor could be in a general purpose computer.

The various processor operations described above may be embodied in executable instructions and stored in a computer readable medium. The processor then operates to perform the various steps via execution of these instructions. At one level, the executable instructions cause the processor to receive a brain signal from a brain monitoring element, receive a cardiac signal from a heart monitoring element, and compare the brain signal to the cardiac signal.

As described above, in a full monitor device for epilepsy, EEG, respiratory and cardiac (ECG) physiologic signals are simultaneously monitored and processed by different algorithms. A seizure-detection algorithm detects seizure activity in the EEG signals. A second algorithm detects heart-rate changes, ECG abnormalities, or unique waveform patterns in the ECG signals, which may or may not be coincident with seizures. Additionally, a third algorithm detects minute ventilation, respiration rate and apnea, which also may or may not be coincident with seizures.

By default, the EEG is considered a 'primary signal'—detections from this signal are used to represent seizure. The ECG and respiratory signals are 'secondary signals'—it is not initially known whether events detected in these two signals are useful for seizure detection. In a treatment setting, the patient's clinician considers the stored signals and data to determine if processing the ECG and respiratory signals provides added benefit in improving detection performance.

To make this determination, the patient is monitored until a sufficient number of detections in one or both of the data streams are observed (number of required events is programmable). Events detected in the EEG data stream may be classified by the user, via the programmer interface, to indicate whether they are clinical seizures (TP-C), sub-clinical seizures (TP-N), or false positive detections (FP). Likewise, events detected in the ECG and respiratory signals may be classified to indicate type of abnormality detected.

The concordance between the EEG seizure detections and ECG and respiratory signals is then evaluated. This is accomplished in one of two ways:

The relation between the EEG and ECG detections is initially unknown. Determination of the relationship between EEG and ECG may be performed with post processing or in real time.

In the post processing embodiment, automated matching tests are performed to identify the temporal relationship of detections in the different data streams. The matching tests identify the number of EEG detections that are within a specified time period with ECG or respiratory abnormalities (EEG-ECG Match or EEG-Respiratory Match, see **864** and **868** FIG. **38**), and those that are not (EEG detect-ECG Normal or EEG detect-Respiratory Normal). For matched detections, the time difference between EEG detection onset and ECG or respiratory detection onset is computed (detection latency). The number of detected events in the ECG or respiratory signals, independent of EEG triggered events, are also computed (ECG Un-matched or Respiratory Un-Matched, see **870** FIG. **38**).

With the real time implementation, the device controls a flag set by the seizure-detection algorithm operating on EEG signals. The flag is a real-time indicator of the subject's seizure state (1=in EEG detection state; 0=out of EEG detection state). In real-time, the device monitors the co-occurrence of the EEG and ECG/respiratory detection states.

The following conditions are assessed:

**Brain-Cardiac Match**—The EEG event (e.g., seizure) is classified as matched with ECG event if the ECG detection state occurs during an EEG detection state or within a specified time period of an EEG detection state.

**Brain-Respiratory Match**—The EEG event (e.g., seizure) is classified as matched with respiratory event if the respiratory detection state occurs during an EEG detection state or within a specified time period of an EEG detection state.

**Brain Detect-Cardiac Normal**—The EEG event (e.g., seizure) is classified as matched with normal ECG if no ECG detection state occurs during an EEG detection state or within a specified time period of an EEG detection state.

**Brain Detect-Respiratory Normal**—The EEG event (e.g., seizure) is classified as matched with normal respiration if no respiratory detection state occurs during an EEG detection state or within a specified time period of the EEG detection state.

**Cardiac Un-Matched**—An ECG event is classified as unmatched to EEG event (e.g., seizure) if no EEG detection state occurs during the ECG detection state or within a specified time period of an ECG detection state.

**Respiratory Un-Matched**—A respiratory event is classified as un-matched to EEG event (e.g., seizure) if no EEG detection state occurs during the respiratory detection state or within a specified time period of the respiratory detection state.

After EEG-ECG or EEG-respiratory matching has been performed, the physician programmer indicates whether the following conditions are true: (1) a high rate of concordance between detections in the EEG and ECG data streams (or between the EEG and respiratory data streams); (2) earlier detection in the ECG signal (or respiratory signal) relative to neurological event onset as indicated in the EEG signal; and (3) a low rate of FP's in the ECG signal (or in the respiratory signal). If these conditions are all true, this may indicate that the ECG signal (or respiratory signal) provides value in neurological event detection (e.g., seizure detection).

Using this information, the physician may choose to activate the ECG algorithm or activate the respiration algorithm—that is, enable it as a primary signal for use in neurological event detection. Determination of whether to “add in” the ECG or respiratory signals (activate it in combination with the EEG signal) for seizure monitoring or treatment is based on satisfying one or more of the above stated conditions. This process can be automated by defining programmable threshold values for each of the stated conditions.

Note that ECG detection and respiratory detection may both be enabled or activated for neurological event detection if they both meet the conditions above.

The physician may decide not to enable the ECG/respiratory algorithms if the matching tests show no additional improvements in detection performance using the ECG or respiratory signals, or if specificity in the ECG/respiratory signals is low. In such cases, the physician may enable a mode of passive ECG recording, with the intended use of documenting cardiovascular changes during stimulation periods in the EEG.

FIG. 40A shows a process 971 for determining whether to enable the cardiac or respiratory detection algorithms for neurological event detection. At block 974 the medical device system monitors a brain signal and, cardiac or respiratory signals. At block 975 detections in any of the 3 signals (brain, cardiac, respiratory) triggers loop recording. Determination of the bounds of the neurological, cardiac and respiratory events may be performed in various ways. In one embodiment this determination of the bounds of events may be performed

by a physician. In another embodiment, such determination of the bounds of the events may be performed by detection algorithms executed by a processor. Block 991 represents this choice between physician marked events and algorithm marked events. In the physician marking embodiment, the loop recording stored data must be uplinked to an external device such as a programmer or other computer. Upon uplinking the loop recording stored data, the physician may score the onset, offset or other reference points in the brain signal at block 976. The physician may also classify the events as related or not to the particular neurological event being targeted. A matching test (brain detections versus cardiac or respiratory detections) is executed at block 977. The brain inputs to the matching test may be either physician markings (e.g., onset, offset of neurological event) or the automated scores from the neurological event detection algorithm. The matching test results from block 977 result in a summary of comparisons made between the brain and cardiac detections (or between the brain and respiratory detections). At block 978 the matching test results are evaluated. The evaluation at block 978 includes blocks 979, 980 and 981 (i.e., blocks 979, 980 and 981 are components of block 978. At block 979 concordance between brain and cardiac/respiratory detections is determined. At block 980 a cardiac or respiratory false positive rate (relative to the neurological signal) is evaluated using the cardiac unmatched events or the respiratory unmatched events in the cardiac or respiratory signals. At block 981 cardiac/respiratory latency is evaluated for the matched detections. At block 982, neurological event detection improvement using cardiac or respiration signals is considered based upon the above determinations. If use of cardiac signals or respiratory signals does not improve neurological event detection (“NO” condition), then the physician or other user may maintain or disable the cardiac event detection algorithm monitoring at block 983. If at block 982 the result is YES, the cardiac or respiratory signal is activated for neurological event monitoring or treatment.

Process 871 in FIG. 40B is one specific embodiment of process 971 in FIG. 40A. Process 871 is a process for determining whether to enable the ECG or respiratory detection algorithms for seizure detection. At block 874 the full monitor monitors EEG and ECG or respiratory signals. At block 875 detections in any of the 3 signals (EEG, ECG or respiratory) triggers loop recording. Determination of the bounds of the seizure, ECG and respiratory events may be performed in various ways. In one embodiment this determination of the bounds of a seizure may be performed by a physician. In another embodiment, such determination of the bounds of the events may be performed by detection algorithms executed by a processor. Block 891 represents this choice between physician marked events and algorithm marked events. In the physician marking embodiment, the loop recording stored data must be uplinked to an external device such as a programmer or other computer. Upon uplinking the loop recording stored data, the physician may score the onset, offset or other reference points in the EEG signal at block 876. The physician may also classify the events as seizure related or not. A matching test (EEG detections versus ECG or respiratory detections) is executed at block 877. The EEG inputs to the matching test may be either physician scores (e.g., onset, offset of seizure) or the automated scores from the neurological event detection algorithm. The matching test results from block 877 result in a summary of comparisons made between the EEG and ECG detections (or between the EEG and respiratory detections). At block 878 the matching test results are evaluated. The evaluation at block 878 includes blocks 879, 880 and 881 (i.e., blocks 879, 880 and 881 are components of

block 878. At block 879 concordance between EEG and ECG/respiratory detections is determined. At block 880 an ECG false positive rate (relative to the neurological signal) is evaluated using the unmatched events in the ECG or respiratory signals. At block 881 ECG/respiratory latency is evaluated for the matched detections. At block 882, seizure detection improvement using ECG or respiration signals is considered based upon the above determinations. If use of ECG signals or respiratory signals does not improve seizure detection ("NO" condition), then the physician or other user may maintain or disable the ECG algorithm monitoring at block 883. The monitor begins monitoring or treatment at block 885. If at block 882 the result is YES, the ECG or respiratory signal is activated for seizure monitoring.

FIG. 41 is a flow chart of a cardiac modulation technique utilizing detected neurological events. With this technique, cardiac therapy may be regulated using the patient's immediate neurological state, with the aim of treating a patient's co morbid cardiac condition. At block 1101 neurological activity is sensed utilizing a brain monitoring element. The brain monitoring element outputs a brain signal reflective of sensed activity in the brain. At block 1121 cardiac activity is sensed utilizing a cardiac monitoring element. The cardiac monitoring element outputs a cardiac signal reflective of sensed activity in the heart. At block 1141 the brain and cardiac signals are preferably simultaneously monitored, although they do not need to be simultaneously monitored. At block 1161 it is determined whether a cardiac event is detected in the monitored cardiac signal. If a cardiac event is not detected, control returns to block 1141 where the brain and cardiac signals are monitored. If a cardiac event was detected at block 1161 then at block 1181 the cardiac therapy module is activated to provide therapy to the heart. Preferably a cardiac detection algorithm as is well known to those of ordinary skill in the art defines a detected cardiac event. Cardiac therapy is implemented according to parameters specified for the detected cardiac event as is well known. At block 1201 it is determined whether a neurological event is detected in the monitored brain signal. If a neurological event is not detected, control is passed to block 1221 where the cardiac therapy module continues to provide the prescribed, standard cardiac therapy. If a neurological event was detected at block 1201, then at block 1241 it is determined whether the cardiac event detected is of a specified nature, as will be described herein after. If it is determined at block 1241 that the cardiac event is of a specified nature, then control is passed to block 1221 where the prescribed, standard cardiac therapy is maintained. However, if it was determined at block 1241 that the cardiac event was not of a specified nature, then at block 1261 the cardiac therapy module is instructed to modulate the prescribed, standard therapy delivered to the heart as will be described.

At block 1241, when the detected cardiac signal is of a specified nature, even though a neurological event has been detected, a decision is made to bypass the modulated cardiac therapy and instead maintain the prescribed, standard cardiac therapy. This bypass of the modulation step for specified cardiac conditions is optional. The specified nature of the detected cardiac event may bradycardia, tachycardia, asystole, wandering pacemaker, multifocal atrial tachycardia, atrial fibrillation, sinus pause, premature atrial contractions (PAC), ST segment elevation, ST segment depression, T-wave inversion, QT interval prolongation, premature ventricular contractions (PVCs), AV-block (AVB), and bundle branch block (BBB). In another embodiment, the specified nature of the cardiac event is not its type but rather its duration which exceeds a predetermined threshold. In yet another

embodiment, the specified nature of the cardiac event is not its type but rather its level of intensity that exceeds a predetermined threshold.

The modulation of the therapy delivered to the heart may take one of several forms. In one embodiment, the modulation comprises temporarily suspending cardiac therapy to the heart for a period of time and then resuming cardiac therapy to the heart after that period of time if the cardiac event is still present. The term suspending means to stop providing the prescribed, standard cardiac therapy so that the cardiac therapy module would not be delivering any electrical stimulation to the heart. The period of time is programmable and may range for a period of seconds. Alternatively, according to an embodiment of the invention, the modulation may comprise a period of time that lasts until the end of the detected neurological event. In yet another embodiment, the period of time lasts for a period of time after the conclusion of the detected neurological event.

In another embodiment, modulation involves the type of cardiac therapy delivered. Thus, if it is determined at block 1261 that the delivered cardiac therapy will be modulated, in one form the modulation involves preventative pacing for a period of time. That period of time is programmable. The preventative pacing may involve decreasing the pacing pulse widths for a period of time and, if the cardiac event is still detected, increasing the pacing pulse widths. The period of time that this modulation may exist could be seconds, could last until the end of the detected neurological event or could last for a period of time after the end of the neurological event. In another embodiment, the preventative pacing may involve decreasing the pacing pulse amplitudes for a period of time and, if the cardiac event is still detected, increasing the pacing pulse amplitudes. The period of time that this modulation may exist could be seconds, could last until the end of the detected neurological event or could last for a period of time after the end of the neurological event. In still another embodiment, the preventative pacing may involve decreasing the pacing pulse frequency for a period of time and, if the cardiac event is still detected, increasing the pacing pulse frequency. The period of time that this modulation may exist could be seconds, could last until the end of the detected neurological event or could last for a period of time after the end of the neurological event. In yet another embodiment, the preventative pacing may involve decreasing the pacing pulse charge density for a period of time and, if the cardiac event is still detected, increasing the pacing pulse charge density. The target charge density for the increased level may be pre-specified, and achieved by modifications (increases/decreases) in voltage, pulse width, or a combination thereof. The period of time that this modulation may exist could be seconds, until the end of the detected neurological event or for a period of time after the end of the neurological event. In yet another embodiment, the preventative pacing involves applying defibrillation shock energy at various levels. For example, a low defibrillation shock energy may be used initially and depending on whether it was effective, the level of the shock energy would progressively increase.

In another embodiment the form of modulation involves debribrillation therapy for a period of time. The period of time is programmable. The debribrillation therapy may involve using a low debribrillation shock energy for a period of time, and, if the cardiac event is still present after the period of time, increasing the debribrillation shock energy.

In one embodiment of the invention, the cardiac monitoring element is a lead electrically coupled to the implantable device at its proximal end and having electrodes located at its distal end that are implanted in or near the heart. Some of the

electrodes are used for sensing cardiac activity. The therapeutic output provided to the heart is provided through the cardiac monitoring element, namely electrodes at its distal end as is well known to those of ordinary skill in the art. The device has the circuitry to perform the various functions of the device.

The implantable device has circuitry located therein that performs the various steps shown in the flow chart of FIG. 41. In particular, as previously discussed with reference to the various embodiments of the monitors it has a processor to run the cardiac event detection algorithm and a neurological event detection algorithms and RAM/ROM memory unit and the device may monitor the cardiac and brain signals. The steps of monitoring the cardiac and brain signals comprises execution of the cardiac event and neurological event detection algorithms respectively to output an indication that a cardiac and/or neurological event is or is not occurring.

In an embodiment of the invention, the device further includes a brain stimulation element that is electrically coupled to the processor. If such a feature is included with the implantable device, at block 1141 the processor is further configured to output a brain stimulation signal to the brain stimulator in response to the neurological event detection algorithm or alternatively, the brain stimulation signal may be delivered at intervals that are either continuous or intermittent.

FIGS. 42A and B are flow charts of a cardiac modulation technique utilizing temporal relationship between cardiac and neurological events. With this technique, cardiac therapy may be regulated using the patient's neurological state history and/or immediate neurological state. At block 1401 neurological activity is sensed with a brain monitoring element and a brain signal is output. At block 1421 cardiac activity is sensed with a cardiac monitoring element and a cardiac signal is output. At blocks 1441 and 1461 respectively, one or more neurological events and cardiac events are identified in the brain and cardiac signal. At block 1481 the brain signal is compared with the cardiac signal. The relationship (expectancy) between cardiac and neurological events is computed. A detected cardiac event with a high degree of concordance to one or more detected neurological events is categorized as being neurologically matched. At block 1501 it is determined whether a cardiac event is detected in the monitored cardiac signal. If a cardiac event has not been detected at block 1501 control is returned to block 1461. If a cardiac event is detected at block 1501 then at block 1521 the cardiac therapy module is activated to provide therapy to the heart. At block 1561, it is determined (using the previous comparison of the brain signal with the cardiac signal in step 1481), whether the cardiac event is categorized as neurologically matched. If it is determined at block 1561 that the cardiac event is not neurologically matched, then at block 1581 the cardiac therapy module continues to deliver the prescribed standard cardiac therapy. If it is determined at block 5161 that the cardiac event is neurologically matched, then at block 1601 the specified nature of the cardiac event is evaluated. If the cardiac event is of a specified nature, then control is returned to block 1581 where the prescribed standard cardiac therapy is maintained. If it was determined at block 1601 that the cardiac event was not of a specified nature, then at block 1621 the cardiac therapy module is instructed to modulate the prescribed therapy delivered to the heart. The specified nature of the cardiac event includes those previously described. In addition, step 1621 is optional.

The modulation of the therapy delivered to the heart may take one of several forms. In one embodiment, the modulation comprises temporarily suspending cardiac therapy to the

heart for a period of time and then resuming cardiac therapy to the heart after that period of time if the cardiac event is still present. The term suspending means to stop providing the prescribed cardiac therapy so that the cardiac therapy module would not be delivering any electrical stimulation to the heart. The period of time is programmable and may range for a period of seconds. Thus for these specified cardiac events, treatment will not be modulated regardless of whether a neurological event is detected.

In another embodiment, modulation involves the type of cardiac therapy delivered. Thus, if it is determined at block 1621 that the delivered cardiac therapy will be modulated after the detection of a neurologically-matched cardiac event and determining that the cardiac event is not of a specified nature, in one form the modulation involves preventative pacing for a period of time. That period of time is programmable. The preventative pacing may involve decreasing the pacing pulse widths for a period of time and, if the cardiac event is still detected, increasing the pacing pulse widths. The period of time that this modulation may exist could be seconds, could last until the end of the detected neurological event or could last for a period of time after the end of the neurological event. In another embodiment, the preventative pacing may involve decreasing the pacing pulse amplitudes for a period of time and, if the cardiac event is still detected, increasing the pacing pulse amplitudes. The period of time that this modulation may exist could be seconds, could last until the end of the detected neurological event or could last for a period of time after the end of the neurological event. In still another embodiment, the preventative pacing may involve decreasing the pacing pulse frequency for a period of time and, if the cardiac event is still detected, increasing the pacing pulse frequency. The period of time that this modulation may exist could be seconds, could last until the end of the detected neurological event or could last for a period of time after the end of the neurological event. In yet another embodiment, the preventative pacing may involve decreasing the pacing pulse charge density for a period of time and, if the cardiac event is still detected, increasing the pacing pulse charge density. The target charge density for the increased level may be pre-specified, and achieved by modifications (increases/decreases) in voltage, pulse width, or a combination thereof. The period of time that this modulation may exist could be seconds, until the end of the detected neurological event or for a period of time after the end of the neurological event. In yet another embodiment, the preventative pacing may include adjusting the shock energy applied by a defibrillator as previously described.

Monitor+Treatment (Brain)

FIG. 43 is a block diagram of the electronic circuitry that makes up full Monitor/Brain Therapy device 300 (FIG. 11) in accordance with the presently disclosed alternative embodiment of the invention. As can be seen from FIG. 43, Monitor/Brain Therapy device 300 comprises a primary control circuit 720 that is described herein above in conjunction with FIG. 26. In addition the Monitor/Brain Therapy device 300 of FIG. 41 also includes an amplifier 725 to amplify and sense EEG signals from a cranially implanted lead (one embodiment of a brain monitoring element 18) and a therapy module for providing therapy to the brain. The therapy module may be a drug delivery pump or an electrical stimulator or a brain cooling mechanism or other components depending on the treatment modality. In the embodiment of FIG. 43, the therapy module is an output stimulator 729 for stimulation of the brain. The CPU 732, in conjunction with software program in RAM/ROM 730, integrates the information from the sensed cardiac, respiration and EEG signals, detects the onset of cerebral,

cardiac or respiratory anomalies, provides preprogrammed stimulation therapy to the patient's brain via a brain lead that may be the same as monitoring element 18, formats and stores diagnostic data for later retrieval by the patient's clinician and, optionally, may warn or alert the patient, patient caregiver or remote monitoring location. See flow diagram and description as described below in association with FIG. 58.

FIG. 44 is a block diagram of the electronic circuitry that makes up full Monitor/Brain Therapy device 320 (FIG. 12A) in accordance with the present disclosed alternative embodiment of the invention. As can be seen from FIG. 44, Monitor/Brain Therapy device 320 comprises a primary control circuit 720 and MV circuit 722 that are described herein above in conjunction with FIG. 28. In addition the Monitor/Brain Therapy device of FIG. 44 also includes an amplifier 725 to amplify and sense EEG signals from a cranially implanted monitoring element 18 and an output stimulator 729 to provide brain stimulation. The CPU 732, in conjunction with software program in RAM/ROM 730, integrates the information from the sensed cardiac, respiration and EEG signals, detects the onset of cerebral, cardiac or respiratory anomalies, provides preprogrammed stimulation therapy to the patient's brain via a lead that may be the same as brain monitoring element 18, formats and stores diagnostic data for later retrieval by the patient's clinician and, optionally, may warn or alert the patient, patient caregiver or remote monitoring location. See flow diagram and description as described below in association with FIG. 58.

FIG. 45 is a block diagram of the electronic circuitry that makes up full Monitor/Brain Therapy device 321 (FIG. 12B) in accordance with the presently disclosed alternative embodiment of the invention. As can be seen from FIG. 45, Monitor/Brain Therapy device 321 in combination with a cranially implanted Monitor/Brain Therapy unit 26 in a patient 10 includes a primary control circuit 720 and MV circuit 722 that are described herein above in conjunction with FIG. 28. A 2-way wireless telemetry communication link 30 connects the Monitor/Therapy unit 26 and Monitor/Brain Therapy unit 321 via antennas 736. The wireless communication link 30 may consist of an RF link (such as described in U.S. Pat. No. 5,683,432 "Adaptive Performance-Optimizing Communication System for Communicating with an Implantable Medical Device" to Goedeke, et al, an electromagnetic/ionic transmission (such as described in U.S. Pat. No. 4,987,897 "Body Bus Medical Device Communication System" to Funke) or acoustic transmission (such as described in U.S. Pat. No. 5,113,859 "Acoustic Body Bus Medical Device Communication System" to Funke). Monitor/Brain Therapy unit 26 contains an amplifier 725 to amplify and sense EEG signals from a cranially implanted brain monitoring element 18 such as a lead and an output stimulator 729 for stimulation of the brain. Monitor 26 may be constructed as substantially described in U.S. Application Publication 2004/0176817, now U.S. Pat. No. 7,212,864, issued May 1, 2007 to Walstrand et al. and entitled "Modular implantable medical device" or U.S. Pat. Nos. 5,782,891 "Implantable Ceramic Enclosure for Pacing, Neurological and Other Medical Applications in the Human Body" to Hasler, et al or 6,427,086 "Means and Method for the Intracranial Placement of a Neurostimulator" to Fischell, et al. EEG sensing is accomplished by the use of integrated electrodes in the housing of monitor 26 or, alternatively, by a brain monitoring element 18 such as a cranially implanted leads.

Specifically, CPU 732, in conjunction with software program in RAM/ROM 730, integrates the information from the sensed cardiac, respiration and EEG signals, detects the onset of cerebral, cardiac or respiratory anomalies, provides pre-

programmed stimulation therapy to the patient's brain via a lead or other therapy delivery device (that could be the same as brain monitoring element 18), formats and stores diagnostic data for later retrieval by the patient's clinician and, optionally, may warn or alert the patient, patient caregiver or remote monitoring location. See flow diagram and description as described below in association with FIG. 56.

FIG. 46 is a block diagram of one embodiment of the electronic circuitry that makes up full Monitor/Brain Therapy device 340 with a brain monitoring element 18 (e.g., lead) and cardiac or respiratory monitoring element 14 such as sensor stub 20 (FIG. 13) in accordance with the presently disclosed alternative embodiment of the invention. As can be seen from FIG. 46, Monitor/Brain Therapy device 340 comprises a primary control circuit 720 and MV circuit 722 that were described herein above in conjunction with FIG. 28. In addition, the full Monitor/Brain Therapy device 340 of FIG. 46 also includes an amplifier 725 to amplify and sense EEG signals from a brain monitoring element 18 such as a cranially implanted lead. Additionally, the full Monitor/Brain Therapy device 340 of FIG. 46 also includes a stimulator 729 for providing stimulation to the brain through brain monitoring element 18 such as a cranially implanted lead. The CPU 732, in conjunction with a software program resident in RAM/ROM 730, integrates the information from the sensed cardiac, respiration and EEG signals, detects the onset of cerebral, cardiac or respiratory anomalies, provides preprogrammed stimulation therapy to the patient's brain via a therapeutic element such as brain monitoring element 18 which may be a lead, formats and stores diagnostic data for later retrieval by the patient's clinician and, optionally, may warn or alert the patient, patient caregiver or remote monitoring location. See flow diagram and description as described below in association with FIG. 58.

FIG. 47 is a block diagram of one embodiment of the electronic circuitry that makes up external patch 160/full Monitor/Brain Therapy device 360 with a brain monitoring element 18 that may be used for sensing and application of therapy (in the case of therapy being electrical stimulation) (FIG. 8) in accordance with the presently disclosed alternative embodiment of the invention. As can be seen from FIG. 47, Monitor/Brain Therapy device 360 comprises a primary control circuit 720 and external patch comprises a cardiac/MV (minute ventilation) circuit 160, the functions of which have been described in detail above in conjunction with the system of FIG. 28. Intrinsic cardiac signals are sensed by electrodes affixed to the patient's skin, amplified by amplifier 724, sent to primary control circuit 720 and processed by CPU 732 and software program resident in RAM/ROM 730. Cardiac anomalies are detected such as heart rate variability, QT variability, QT<sub>c</sub>, sinus arrest, and various arrhythmias such as sinus, atrial and ventricular tachycardias. Respiration sensing is accomplished by low pass filtering the sensed and amplified intrinsic cardiac signals as shown in FIG. 27 or, alternatively, by using the MV/Z measurement circuitry of external patch 160 as described above in connection with FIG. 28. Respiration anomalies (such as reduced or cessation of tidal volume and apnea) are evaluated and detected by CPU 732 and software resident in RAM/ROM 730.

The CPU 732, in conjunction with a software program resident in RAM/ROM 730, integrates the information from the sensed cardiac, respiration and EEG signals, detects the onset of cerebral, cardiac or respiratory anomalies, provides preprogrammed stimulation therapy to the patient's brain via lead 18, formats and stores diagnostic data for later retrieval by the patient's clinician and, optionally, may warn or alert

the patient, patient caregiver or remote monitoring location. See flow diagram and description as described below in association with FIG. 58.

The circuitry and function of the device 340 shown in FIG. 46 and described herein above may also be used for the full Monitor/Brain Therapy device 380 with integrated electrode 24 brain lead 18 (FIG. 15). As described above in association with core Monitor 340, thoracic impedance via impedance/voltage converter as measured from the case of monitor 340 to the integrated electrode 24 using a sampling frequency of approximately 16 Hz as substantially described in U.S. Pat. No. 4,596,251 "Minute Ventilation Dependant Rate Responsive Pacer" to Plicchi, et al. The Monitor 380 of this alternative embodiment utilizes the same circuitry of Monitor 340 but connected to the integrated electrode 24 on brain lead 18 instead of the sensor stub of Monitor 340.

Upon detection of either/or a cardiac or respiration anomaly, CPU 732, under control of firmware resident in RAM/ROM 730, will initiate recording of the appropriate diagnostic information into RAM of RAM/ROM 730, provides preprogrammed stimulation therapy to the patient's brain via lead 18, formats and stores diagnostic data for later retrieval by the patient's clinician and, optionally, may warn or alert the patient, patient caregiver or remote monitoring location. See flow diagram and description as described below in association with FIG. 58.

FIG. 48 is a block diagram of the electronic circuitry that makes up full Monitor/Brain Therapy device 400 (FIG. 20) in accordance with the presently disclosed alternative embodiment of the invention. As can be seen from FIG. 48, Monitor/Brain Therapy device 400 comprises a primary control circuit 720 (sensing cardiac and respiration parameters) that is described herein above in conjunction with FIG. 26. In addition the Monitor/Brain Therapy device 400 connects via a 2-way wireless communication link 30 to a cranially implanted EEG sensor and brain stimulator 26. EEG sensor and brain stimulator 26 contains an amplifier 725 to amplify and sense EEG signals from a cranially implanted lead 18 and an output stimulator 729 for stimulation of the brain. The CPU 732, in conjunction with software program in RAM/ROM 730, integrates the information from the sensed cardiac, respiration and EEG signals, detects the onset of cerebral, cardiac or respiratory anomalies, provides preprogrammed stimulation therapy to the patient's brain via lead 18, formats and stores diagnostic data for later retrieval by the patient's clinician and, optionally, may warn or alert the patient, patient caregiver or remote monitoring location. See flow diagram and description as described below in association with FIG. 58.

FIG. 49 is a block diagram of the electronic circuitry that makes up full Monitor/Brain Therapy device 420 (FIG. 21) in accordance with the presently disclosed alternative embodiment of the invention. As can be seen from FIG. 49, Monitor/Brain Therapy device 420 comprises a primary control circuit 720 (sensing cardiac and respiration parameters) that is configured as an external patch affixed to a patient and whose function is described herein above in conjunction with FIG. 26. In addition, the Monitor/Brain Therapy device 420 comprises to a cranially implanted EEG sensor and brain stimulator 26 connected to the primary control circuit 720 via a 2-way wireless communication link 30. The wireless communication link 30 may consist of an RF link (such as described in U.S. Pat. No. 5,683,432 "Adaptive Performance-Optimizing Communication System for Communicating with an Implantable Medical Device" to Goedeke, et al.), an electromagnetic/ionic transmission (such as described in U.S. Pat. No. 4,987,897 "Body Bus Medical Device Communica-

tion System" to Funke) or acoustic transmission (such as described in U.S. Pat. No. 5,113,859 "Acoustic Body Bus Medical Device Communication System" to Funke). EEG sensor and brain stimulator 26 contains an amplifier 725 to amplify and sense EEG signals from a cranially implanted lead 18 and an output stimulator 729 for stimulation of the brain. The CPU 732, in conjunction with software program in RAM/ROM 730, integrates the information from the sensed cardiac, respiration and EEG signals, detects the onset of cerebral, cardiac or respiratory anomalies, provides preprogrammed stimulation therapy to the patient's brain via lead 18, formats and stores diagnostic data for later retrieval by the patient's clinician and, optionally, may warn or alert the patient, patient caregiver or remote monitoring location. See flow diagram and description as described below in association with FIG. 58.

Monitor+Treatment (Brain+Respiration)

FIG. 50 is a block diagram of the electronic circuitry that makes up full Monitor/Brain and Respiration Therapy device 440 (FIG. 16A) in accordance with the presently disclosed alternative embodiment of the invention. As can be seen from FIG. 50, Monitor/Brain and Respiration Therapy device 440 comprises a primary control circuit 720 and MV circuit 722 whose function was described herein above in conjunction with FIG. 28. In addition the Monitor/Brain and Respiration Therapy device of FIG. 50 also includes an amplifier 725 to amplify and sense EEG signals from a cranially implanted lead 18 and an output stimulator 729 to provide brain stimulation via cranially implanted lead 18 and phrenic nerve stimulation via respiration lead 28. The CPU 732, in conjunction with software program in RAM/ROM 730, integrates the information from the sensed cardiac, respiration and EEG signals, detects the onset of cerebral, cardiac or respiratory anomalies, provides preprogrammed stimulation therapy to the patient's brain via lead 18 and stimulation of the patient's phrenic nerve via respiration lead 28, formats and stores diagnostic data for later retrieval by the patient's clinician and, optionally, may warn or alert the patient, patient caregiver or remote monitoring location. Optionally, lead 28 may connect to the diaphragm to provide direct diaphragmatic stimulation. See flow diagram and description as described below in association with FIG. 58.

FIG. 51 is a block diagram of the electronic circuitry that makes up full Monitor/Brain and Respiration Therapy device 441 (FIG. 16B) in accordance with the presently disclosed alternative embodiment of the invention. As can be seen from FIG. 51, Monitor/Brain and Respiration Therapy device 441 in combination with a cranially implanted Monitor/Brain Therapy unit 26 in a patient 10 includes a primary control circuit 720 and MV circuit 722 that are described herein above in conjunction with FIG. 28. A 2-way wireless telemetry communication link 30 connects the Monitor/Therapy unit 26 and Monitor/Brain and Respiration Therapy unit 441 via antennas 736. The wireless communication link 30 may consist of an RF link (such as described in U.S. Pat. No. 5,683,432 "Adaptive Performance-Optimizing Communication System for Communicating with an Implantable Medical Device" to Goedeke, et al), an electromagnetic/ionic transmission (such as described in U.S. Pat. No. 4,987,897 "Body Bus Medical Device Communication System" to Funke) or acoustic transmission (such as described in U.S. Pat. No. 5,113,859 "Acoustic Body Bus Medical Device Communication System" to Funke). Monitor/Brain Therapy unit 26 contains an amplifier 725 to amplify and sense EEG signals from a cranially implanted lead 18 and an output stimulator 729 for stimulation of the brain. Monitor 26 may be constructed as substantially described in U.S. Application Pub-

lication 2004/0176817, now U.S. Pat. No. 7,212,864, issued May 1, 2007 to Walstrand et al. and entitled "Modular implantable medical device" or U.S. Pat. Nos. 5,782,891 "Implantable Ceramic Enclosure for Pacing, Neurological and Other Medical Applications in the Human Body" to Has-

5 sler, et al or 6,427,086 "Means and Method for the Intracranial Placement of a Neurostimulator" to Fischell, et al. EEG sensing is accomplished by the use of integrated electrodes in the housing of monitor 26 or, alternatively, by cranially implanted leads 18.

Specifically, CPU 732, in conjunction with software program in RAM/ROM 730, integrates the information from the sensed cardiac, respiration and EEG signals, detects the onset of cerebral, cardiac or respiratory anomalies, provides pre-programmed stimulation therapy to the patient's brain via lead 18 and to the phrenic nerve via respiration lead 28, formats and stores diagnostic data for later retrieval by the patient's clinician and, optionally, may warn or alert the patient, patient caregiver or remote monitoring location. Optionally, lead 28 may connect to the diaphragm to provide direct diaphragmatic stimulation. See flow diagram and description as described below in association with FIG. 58.

FIG. 52 is a block diagram of the electronic circuitry that makes up full Monitor/Brain and Respiration Therapy device 460 with a brain lead 18, phrenic nerve lead 28 and sensor stub 20 (FIG. 17) in accordance with the presently disclosed alternative embodiment of the invention. As can be seen from FIG. 52, Monitor/Brain and Respiration Therapy device 460 comprises a primary control circuit 720 and MV circuit 722 whose function was described herein above in conjunction with FIG. 28. In addition, the full Monitor/Brain and Respiration Therapy device 460 of FIG. 52 also includes an amplifier 725 to amplify and sense EEG signals from a cranially implanted lead 18. Additionally, the full Monitor/Brain Therapy device 340 of FIG. 46 also includes a stimulator 729 for providing stimulation to the brain through cranially implanted lead 18 and phrenic nerve stimulation via respiration lead 28. The CPU 732, in conjunction with a software program resident in RAM/ROM 730, integrates the information from the sensed cardiac, respiration and EEG signals, detects the onset of cerebral, cardiac or respiratory anomalies, provides preprogrammed stimulation therapy to the patient's brain via lead 18 and stimulation of the patient's phrenic nerve via respiration lead 28, formats and stores diagnostic data for later retrieval by the patient's clinician and, optionally, may warn or alert the patient, patient caregiver or remote monitoring location. See flow diagram and description as described below in association with FIG. 58.

The circuitry and function of the device 460 shown in FIG. 52 and described herein above may also be used for the full Monitor/Brain and Respiration Therapy device 480 with integrated electrode 24 brain lead 18 and phrenic nerve lead 28 (FIG. 18). As described above in association with Monitor/Brain and Respiration Therapy device 460, thoracic impedance via impedance/voltage converter as measured from the case of monitor 480 to the integrated electrode 24 using a sampling frequency of approximately 16 Hz as substantially described in U.S. Pat. No. 4,596,251 "Minute Ventilation Dependant Rate Responsive Pacer" to Plicchi, et al. The Monitor/Brain and Respiration Therapy device 480 of this alternative embodiment utilizes the same circuitry of Monitor/Brain and Respiration Therapy device 460 but connected to the integrated electrode 24 on brain lead 18 instead of the sensor stub 20 of Monitor/Brain and Respiration Therapy device 340.

Upon detection of either/or a cardiac or respiration anomaly, CPU 732, under control of firmware resident in

RAM/ROM 730, will initiate recording of the appropriate diagnostic information into RAM of RAM/ROM 730, provides preprogrammed stimulation therapy to the patient's brain via lead 18 and stimulation of the patient's phrenic nerve via respiration lead 28, formats and stores diagnostic data for later retrieval by the patient's clinician and, optionally, may warn or alert the patient, patient caregiver or remote monitoring location. See flow diagram and description as described below in association with FIG. 58.

10 The circuitry and function of the device 460 shown in FIG. 52 and described herein above may also be used for the full Monitor/Brain and Respiration Therapy device 500 with brain lead 18 and integrated electrode 24 phrenic nerve lead 28 (FIG. 19). As described above in association with Monitor/Brain and Respiration Therapy device 460, thoracic impedance via impedance/voltage converter as measured from the case of monitor 500 to the integrated electrode 24 using a sampling frequency of approximately 16 Hz as substantially described in U.S. Pat. No. 4,596,251 "Minute Ventilation Dependant Rate Responsive Pacer" to Plicchi, et al. The Monitor/Brain and Respiration Therapy device 500 of this alternative embodiment utilizes the same circuitry of Monitor/Brain and Respiration Therapy device 460 but connected to the integrated electrode 24 on phrenic nerve lead 28 instead of the sensor stub 20 of Monitor/Brain and Respiration Therapy device 340.

Upon detection of either/or a cardiac or respiration anomaly, CPU 732, under control of firmware resident in RAM/ROM 730, will initiate recording of the appropriate diagnostic information into RAM of RAM/ROM 730, provides preprogrammed stimulation therapy to the patient's brain via lead 18 and stimulation of the patient's phrenic nerve via respiration lead 28, formats and stores diagnostic data for later retrieval by the patient's clinician and, optionally, may warn or alert the patient, patient caregiver or remote monitoring location. See flow diagram and description as described below in association with FIG. 58.

Monitor+Treatment (Brain+Cardiac)

FIG. 53 is a block diagram of the electronic circuitry that makes up full Monitor/Brain and Cardiac Therapy device 520 (FIG. 24A) in accordance with the presently disclosed alternative embodiment of the invention. As can be seen from FIG. 53, Monitor/Brain and Cardiac Therapy device 520 comprises a primary control circuit 720 and MV circuit 722 whose function is described herein above in conjunction with FIG. 28 and U.S. Pat. No. 5,271,395 "Method and Apparatus for Rate Responsive Cardiac Pacing" to Wahlstrand et al. In addition, the Monitor/Brain and Cardiac Therapy device of FIG. 53 also includes an amplifier 725 to amplify and sense EEG signals from a cranially implanted lead 18 and an output stimulator 729 to provide brain stimulation. The CPU 732, in conjunction with software program in RAM/ROM 730, integrates the information from the sensed cardiac, respiration and EEG signals, detects the onset of cerebral, cardiac or respiratory anomalies, provides preprogrammed stimulation therapy to the patient's brain via lead 18 and stimulation to the patient's heart via cardiac lead(s) 16, formats and stores diagnostic data for later retrieval by the patient's clinician and, optionally, may warn or alert the patient, patient caregiver or remote monitoring location. See flow diagram and description as described below in association with FIG. 56.

FIG. 54 is a block diagram of the electronic circuitry that makes up full Monitor/Brain and Cardiac Therapy device 521 (FIG. 24B) in accordance with the presently disclosed alternative embodiment of the invention. As can be seen from FIG. 54, Monitor/Brain and Cardiac Therapy device 521 in combination with a cranially implanted Monitor/Brain Therapy

unit **26** in a patient **10** includes a primary control circuit **720** and MV circuit **722** that are described herein above in conjunction with FIG. **28**. A 2-way wireless telemetry communication link **30** connects the Monitor/Therapy unit **26** and Monitor/Brain and Cardiac Therapy unit **521** via antennas **736**. The wireless communication link **30** may consist of an RF link (such as described in U.S. Pat. No. 5,683,432 "Adaptive Performance-Optimizing Communication System for Communicating with an Implantable Medical Device" to Goedeke, et al), an electromagnetic/ionic transmission (such as described in U.S. Pat. No. 4,987,897 "Body Bus Medical Device Communication System" to Funke) or acoustic transmission (such as described in U.S. Pat. No. 5,113,859 "Acoustic Body Bus Medical Device Communication System" to Funke). Monitor/Brain Therapy unit **26** contains an amplifier **725** to amplify and sense EEG signals from a cranially implanted lead **18** and an output stimulator **729** for stimulation of the brain. Monitor **26** may be constructed as substantially described in U.S. Application Publication 2004/0176817, now U.S. Pat. No. 7,323,864, issued May 1, 2007 to Walstrand et al. and entitled "Modular implantable medical device" U.S. Pat. Nos. 5,782,891 "Implantable Ceramic Enclosure for Pacing, Neurological and Other Medical Applications in the Human Body" to Hassler, et al or 6,427,086 "Means and Method for the Intracranial Placement of a Neurostimulator" to Fischell, et al. EEG sensing is accomplished by the use of integrated electrodes in the housing of monitor **26** or, alternatively, by cranially implanted leads **18**.

Specifically, CPU **732**, in conjunction with software program in RAM/ROM **730**, integrates the information from the sensed cardiac, respiration and EEG signals, detects the onset of cerebral, cardiac or respiratory anomalies, provides preprogrammed stimulation therapy to the patient's brain via lead **18** and cardiac stimulation via cardiac leads **16**, formats and stores diagnostic data for later retrieval by the patient's clinician and, optionally, may warn or alert the patient, patient caregiver or remote monitoring location. See flow diagram and description as described below in association with FIG. **58**.

Alternatively, the device as described above in connection to the Monitor and Treatment (Brain and Cardiac) system of FIG. **54** may include a pacemaker/cardioverter/defibrillator (PCD) to enable the termination of cardiac arrhythmias during, or prior to, neurological events. The PCD may be of the type as substantially described in U.S. Pat. No. 5,545,186 "Prioritized Rule Based Method and Apparatus for Diagnosis and Treatment of Arrhythmias" to Olson; U.S. Pat. No. 5,354,316 "Method and Apparatus for Detection and Treatment of Tachycardia and fibrillation" to Kiemel or U.S. Pat. No. 5,314,430 "Atrial Defibrillator Employing Transvenous and Subcutaneous Electrodes and Method of Use" to Bardy. In one embodiment of the present invention, the PCD arrhythmia detection circuitry/algorithms are enabled upon the sensing of the onset or impending onset of a seizure. Upon seizure termination, the arrhythmia detection circuitry/algorithms are turned off.

FIG. **55** is a block diagram of the electronic circuitry that makes up full Monitor/Brain and Cardiac Therapy device **540** (FIG. **22**) in accordance with the presently disclosed alternative embodiment of the invention. The system as shown in FIG. **55** is used for patients temporarily at risk of sudden death, for example, while the patient's physician is trying different epileptic drugs and titrating dosages to eliminate/minimize seizures or their severity. As can be seen from FIG. **55**, Monitor/Brain and Cardiac Therapy device **540** comprises patient worn vest defibrillator **34** containing primary control circuit **720** whose function is described herein above

in conjunction with FIG. **26** and in more detail in U.S. Pat. No. 6,280,461 "Patient-Worn Energy Delivery Apparatus" to Glegyak, et. In addition the Monitor/Brain and Cardiac Therapy device connects via a 2-way wireless communication link **30** to a cranially implanted brain stimulator **540**. The wireless communication link **30** may consist of an RF link (such as described in U.S. Pat. No. 5,683,432 "Adaptive Performance-Optimizing Communication System for Communicating with an Implantable Medical Device" to Goedeke, et al), an electromagnetic/ionic transmission (such as described in U.S. Pat. No. 4,987,897 "Body Bus Medical Device Communication System" to Funke) or acoustic transmission (such as described in U.S. Pat. No. 5,113,859 "Acoustic Body Bus Medical Device Communication System" to Funke). EEG sensor and brain stimulator **540** contains an amplifier **725** to amplify and sense EEG signals from a cranially implanted lead **18** and an output stimulator **729**. The CPU **732**, in conjunction with software program in RAM/ROM **730**, integrates the information from the sensed cardiac, respiration and EEG signals, detects the onset of cerebral, cardiac or respiratory anomalies, provides preprogrammed stimulation therapy to the patient's brain via lead **18** and defibrillation therapy via patient worn vest **34**, formats and stores diagnostic data for later retrieval by the patient's clinician and, optionally, may warn or alert the patient, patient caregiver or remote monitoring location. See flow diagram and description as described below in association with FIG. **58**.

The circuitry and function of the device **540** shown in FIG. **55** and described herein above may also be used for the full Monitor/Brain and Cardiac Therapy device **560** with a cranially implanted stimulator in 2-way communication with an leadless subcutaneous implantable defibrillator **36** (ie, "lifeboat", FIG. **23**). The system described in connection with this embodiment is used for patients temporarily at risk of sudden death, for example, while the patient's physician is trying different epileptic drugs and titrating dosages to eliminate/minimize seizures or their severity. As described above in conjunction with FIG. **55**, Monitor/Brain and Cardiac Therapy device **560** comprises a leadless defibrillator **36** containing primary control circuit **720** whose function is described herein above in conjunction with FIG. **26** and in more detail in U.S. Pat. No. 6,647,292 "Unitary Subcutaneous only Implantable Cardioverter-Defibrillator and Optional Pacer" to Bardy.

The Monitor/Brain and Cardiac Therapy device connects via a 2-way wireless communication link **30** to a cranially implanted brain stimulator **560**. The wireless communication link **30** may consist of an RF link (such as described in U.S. Pat. No. 5,683,432 "Adaptive Performance-Optimizing Communication System for Communicating with an Implantable Medical Device" to Goedeke, et al), an electromagnetic/ionic transmission (such as described in U.S. Pat. No. 4,987,897 "Body Bus Medical Device Communication System" to Funke) or acoustic transmission (such as described in U.S. Pat. No. 5,113,859 "Acoustic Body Bus Medical Device Communication System" to Funke). EEG sensor and brain stimulator **560** contains an amplifier **725** to amplify and sense EEG signals from a cranially implanted lead **18** and an output stimulator **729**. The CPU **732**, in conjunction with software program in RAM/ROM **730**, integrates the information from the sensed cardiac, respiration and EEG signals, detects the onset of cerebral, cardiac or respiratory anomalies, provides preprogrammed stimulation therapy to the patient's brain via lead **18** and defibrillation therapy via implanted defibrillator **36**, formats and stores diagnostic data for later retrieval by the patient's clinician and, optionally, may warn or alert the

patient, patient caregiver or remote monitoring location. See flow diagram and description as described below in association with FIG. 58.

Monitor+Treatment (Brain+Respiration+Cardiac)

FIG. 56 is a block diagram of the electronic circuitry that makes up full Monitor/Brain, Respiration and Cardiac Therapy device 580 (FIG. 25A) in accordance with the presently disclosed alternative embodiment of the invention. As can be seen from FIG. 56, Monitor/Brain, Respiration and Cardiac Therapy device 580 comprises a primary control circuit 720 and MV circuit 722 whose function was described herein above in conjunction with FIG. 28. In addition the Monitor/Brain, Respiration and Cardiac Therapy device of FIG. 56 also includes an amplifier 725 to amplify and sense EEG signals from a cranially implanted lead 18 and an output stimulator 729 to provide brain stimulation via cranially implanted lead 18 and phrenic nerve stimulation via respiration lead 28. The CPU 732, in conjunction with software program in RAM/ROM 730, integrates the information from the sensed cardiac, respiration and EEG signals, detects the onset of cerebral, cardiac or respiratory anomalies, provides preprogrammed stimulation therapy to the patient's brain via lead 18, stimulation of the patient's phrenic nerve via respiration lead 28 and stimulation of the patient's heart via cardiac leads 16, formats and stores diagnostic data for later retrieval by the patient's clinician and, optionally, may warn or alert the patient, patient caregiver or remote monitoring location. Optionally, lead 28 may connect to the diaphragm to provide direct diaphragmatic stimulation. See flow diagram and description as described below in association with FIG. 58.

FIG. 57 is a block diagram of the electronic circuitry that makes up full Monitor/Brain, Respiration and Cardiac Therapy device 581 (FIG. 25B) in accordance with the presently disclosed alternative embodiment of the invention. As can be seen from FIG. 57, Monitor/Brain, Respiration and Cardiac Therapy device 581 in combination with a cranially implanted Monitor/Brain Therapy unit 26 in a patient 10 includes a primary control circuit 720 and MV circuit 722 that are described herein above in conjunction with FIG. 28. A 2-way wireless telemetry communication link 30 connects the Monitor/Therapy unit 26 and Monitor/Brain, Respiration and Cardiac Therapy unit 581 via antennas 736. The wireless communication link 30 may consist of an RF link (such as described in U.S. Pat. No. 5,683,432 "Adaptive Performance-Optimizing Communication System for Communicating with an Implantable Medical Device" to Goedeke, et al), an electromagnetic/ionic transmission (such as described in U.S. Pat. No. 4,987,897 "Body Bus Medical Device Communication System" to Funke) or acoustic transmission (such as described in U.S. Pat. No. 5,113,859 "Acoustic Body Bus Medical Device Communication System" to Funke). Monitor/Brain Therapy unit 26 contains an amplifier 725 to amplify and sense EEG signals from a cranially implanted lead 18 and an output stimulator 729 for stimulation of the brain. Monitor 26 may be constructed as substantially described in U.S. Application Publication 2004/0176817, now U.S. Pat. No. 7,212,864, issued May 1, 2007 to Walstrand et al. and entitled "Modular implantable medical device" or U.S. Pat. Nos. 5,782,891 "Implantable Ceramic Enclosure for Pacing, Neurological and Other Medical Applications in the Human Body" to Hassler, et al or 6,427,086 "Means and Method for the Intracranial Placement of a Neurostimulator" to Fischell, et al. EEG sensing is accomplished by the use of integrated electrodes in the housing of monitor 26 or, alternatively, by cranially implanted leads 18.

Specifically, CPU 732, in conjunction with software program in RAM/ROM 730, integrates the information from the sensed cardiac, respiration and EEG signals, detects the onset of cerebral, cardiac or respiratory anomalies, provides preprogrammed stimulation therapy to the patient's brain via lead 18, to the phrenic nerve via respiration lead 28 and to the heart via cardiac leads 16, formats and stores diagnostic data for later retrieval by the patient's clinician and, optionally, may warn or alert the patient, patient caregiver or remote monitoring location. Optionally, lead 28 may connect to the diaphragm to provide direct diaphragmatic stimulation. See flow diagram and description as described below in association with FIG. 58.

FIG. 58 is a flow diagram 850 showing operation of a full monitor/therapy sensing and monitoring cardiac, respiration and electroencephalogram parameters for the detection of neurological events as shown and described in embodiments in FIG. 11-25 above. The blocks 802-808 relating to the identification of cardiac activity, and blocks 816-822 relating to identification of respiratory activity, may be activated or deactivated according to the determination of whether they improve the detection of the neurological disorder (see for example the discussion regarding determining concordance). It is noted that the particular detection scheme used for each of the physiologic signals (brain, heart, respiratory) is not restricted to the examples provided here.

In one embodiment, beginning at block 802, the interval between sensed cardiac signals are measured. At block 804, a rate stability measurement is made on each cardiac interval utilizing a heart rate average from block 806. At block 808, a rate stable decision is made based upon preprogrammed parameters. If YES (heart rate is determined to be stable), the flow diagram returns to the HR Measurement block 802. If NO, the rate stability information is provided to Determine Therapy and Duration block 830.

At block 816, thoracic impedance is continuously measured in a sampling operation. At block 818, a MV and respiration rate calculation is made. At block 822, a pulmonary apnea decision is made based upon preprogrammed criteria. If NO (no apnea detected), the flow diagram returns to MV Measurement block 816. If YES, the occurrence of apnea and MV information is provided to Determine Therapy and Duration block 830.

At block 824, the electroencephalogram is sensed and measured. An EEG calculation is performed at block 826. The seizure detection algorithm is executed at block 826. At block 828, a seizure episode is determined. If NO (no seizure detected), the flow diagram returns to EEG Measurement block 824. If YES, the occurrence of a seizure is provided to Determine Therapy and Duration block 830.

Based upon the data presented to it, Determine Therapy and Duration block 830 determines the type of therapy and the duration to block 832, which controls the start of the therapy by evaluating the severity and ranking of each event (i.e., maximum ratio, duration of seizure detection, spread, number of clusters per unit time, number of detections per cluster, duration of an event cluster, duration of a detection, and inter-seizure interval) per U.S. patent application Publication No. 20040133119 "Scoring of sensed neurological signals for use with a medical device system" to Osorio, et al, which is still pending and incorporated herein by reference in its entirety. Block 834 monitors the completion of the determined therapy. If the therapy is not complete, control returns to block 834. If the therapy is determined to be complete, block 834 returns the flow diagram to blocks 802 (Measure

HR), **816** (Measure Impedance) and **824** (Measure EEG) to continue the monitoring of cardiac, respiratory and brain signal parameters.

Therapy may consist of neural stimulation, cardiac pacing, cardioversion/defibrillation; and drug delivery via a pump, brain cooling, or any combination of therapies.

When block **830** determines that a therapy is to be initiated Format Diagnostic Data block **812** formats the data from the cardiac, respiration and EEG monitoring channels, adds a time stamp (ie, date and time), type and duration of therapy and provides the data to block **814** where the data is stored in RAM memory for later retrieval by a clinician via telemetry. Optionally, block **812** may add examples of intrinsic ECG, respiration or EEG signals recorded during a sensed episode/seizure.

The physician may program the devices shown above in relation to FIGS. **11-25** and **41-57** to allow the ECG/respiratory detectors be enabled to trigger the delivery of therapy (i.e., stimulation or drug delivery) to the patient's brain, with goal of aborting seizures earlier or limiting their severity than if using EEG signal detection alone. Either EEG, respiratory or ECG detections may trigger therapy to the brain, depending on which occurs first. The physician may choose the type of ECG or respiratory event to use for triggering therapy to the brain.

Application of Therapy to the Brain Based on Cardiac or Respiratory Signals and Termination of Such Therapy

In the present invention of the devices shown above in relation to FIGS. **11-25** and **41-57**, the device is able to terminate or change the cardiac/respiratory initiated treatment, directed at the brain, if a neurological event is not entered within an expected time frame following cardiac detection. This feature allows the device to begin treating a patient's neurological event before its detection in the brain signal. These termination conditions are defined at block **990** of FIG. **40A** and **890** of FIG. **40B**.

If the cardiac/respiratory initiated brain therapy has been ongoing for some time, and polling of the brain signal (i.e., processing the brain signal with a neurological event detection algorithm) has indicated the patient is not in a neurological event, then the following may be true:

1. Cardiac/respiratory triggered therapy was successful in aborting the neurological event, and therefore, the neurological event is not detectable in the brain signal.
2. The cardiac/respiratory event was not associated with a neurological event.

In either case, it would be appropriate to change (adjust or terminate) cardiac/respiratory initiated therapy directed specifically at aborting a neurological event. FIG. **59A** is a flow chart illustrating the processing steps executed by a processor (e.g., CPU **732** or any other processor). At block **1000** the processor monitors the cardiac or respiratory signals. At block **1002**, the processor detects a cardiac or respiratory event in the cardiac or respiratory signals. Based upon a cardiac or respiratory event detection at block **1002**, the processor activates the therapy module to provide therapy to the brain at block **1004**. The brain signal is monitored at block **1006**. This may be a continuation of monitoring of the brain that was already ongoing or it may be initiation of brain monitoring. Once the therapy has been initiated from a cardiac or respiratory detection, the therapy may be changed at block **1008** based on the monitoring of the brain signal.

One embodiment of the process of FIG. **59A** is illustrated in FIG. **59B**. The processor receives the cardiac or respiratory signals at block **1050**. A cardiac or respiratory event is detected at block **1052**. The therapy module is activated at block **1054** to provide therapy to the brain based on a cardiac

or respiratory detection. Once therapy has been initiated from a cardiac/respiratory detection, the device monitors the amount of time therapy has been delivered at block **1056**. This time period is programmable. The processor continues to receive a brain signal at block **1058**. At decision block **1060** the processor determines when the programmed time period has been exceeded without detection of a neurological event in the brain signal. If the answer is "Yes" (i.e., the cardiac or respiratory initiated brain therapy has been ongoing for the programmed time period without the occurrence of a neurological event in the brain signal), then therapy to the brain is discontinued at block **1062**. If the patient has entered a neurological event while receiving cardiac/respiratory initiated therapy, control of therapy is transferred to the monitoring of the brain by the neurological event detection algorithm, and therapy decisions are made using the brain signals at block **1064**. At this point therapy may continue until the EEG detection algorithm determines that the neurological event has ended. Then therapy may be terminated based on the detected end of the neurological event based on the EEG detection algorithm output.

FIG. **40A** discussed above shows a process **971** for determining whether to enable the cardiac or respiratory detectors for neurological event detection and treatment. Once the cardiac or respiratory signals have been enabled for neurological event detection monitoring and treatment at block **986** and the neurological event detection algorithm has been enabled for modulation or other input into cardiac or respiratory therapy, the cardiac/respiratory parameters for stimulation/post-stimulation treatment options are defined at block **987**. At block **988**, cardiac/respiratory events to treat when in a neurological state are defined. At block **989**, cardiac/respiratory events to treat when outside a neurological event are defined. At block **990**, therapy termination conditions (i.e., turn over control of brain therapy to the neurological event detection algorithm and terminate if a neurological event is not entered in a programmable period of time) are defined and the monitor starts monitoring or treatment at block **985**.

If the matching test of the flow diagram of FIG. **40A** shows that one type of cardiac event (type 1) is associated with neurological event onset while other types of cardiac events (type 2) occur frequently, but have no temporal relationship to the neurological event, then the physician may choose to direct therapy to the Brain (or Brain and Heart) upon type 1 event detection or direct therapy to the Heart on type 2 detection.

In the present invention as described in relation to the devices shown above in FIGS. **11-25** and **41-57**, the physician is able to selectively choose which cardiac and respiratory events to treat in seizure and non-seizure states. For example, the device may be programmed to treat incidences of tachycardia in non-seizure states, but not in seizure states, where this type of cardiac behavior is expected and considered normal. Also, the patient may experience certain ECG or respiratory abnormalities, which are seizure induced, but cause no complications or increased health risk to the patient. In such cases, the physician may decide to suppress treatment for these events if detected during a seizure. This cannot be accomplished with existing pacemaker technology, which operates on ECG signals only.

There are other instances in which a detected ECG or respiratory abnormality does pose a health risk, regardless of when it occurs and how it was induced. For these events, the physician may choose a mode of operation that treats the ECG/respiratory abnormality in both seizure and non-seizure states (i.e., asystole, apnea).

Additionally, the physician may choose to treat the same ECG/respiratory event in both seizure and non-seizure states,

but may define different thresholds (i.e., duration or intensity) for treating the event. For example, during a seizure state, a higher heart rate or sustained occurrence of tachycardia may be required before cardiac treatment is initiated, relative to a non-seizure state. This feature would enable cardiac therapy during status epilepticus, which is a prolonged condition, but suppress it for typical seizure behaviors.

If the matching test of the flow diagram of FIG. 59 shows that the ECG or respiratory signals do not improve seizure detection, but patient is at cardiac risk, the physician may choose to enable the ECG/respiratory detector to deliver therapy to the heart or diaphragm.

If the matching test of the flow diagram of FIG. 59 shows that the ECG or respiratory signals improves seizure detection, but the patient is also at cardiac risk, the physician may choose to treat the brain (for seizures) with EEG, ECG or respiratory detection, and heart (for cardiac problems) with ECG detection.

#### Preventative Pacing Therapy

Optionally, the therapy systems of FIGS. 11-25 and 41-57 may also have pre-emptive or preventative pacing capabilities. For example, upon EEG detection of seizure onset or imminent seizure onset, the pacing systems described in conjunction with FIGS. 11-25 and 41-57 may begin preventative overdrive pacing to prevent or mitigate sleep apnea such as described in U.S. Pat. No. 6,126,611 "Apparatus for Management of Sleep Apnea" to Bourgeois. The '611 patent detects sleep apnea and begins to pace the heart at a rate of 70-100 PPM (overdrive pacing the sleep intrinsic rate of typically 30-55 BPM) causing arousal and elimination/prevention of sleep apnea. The herein described invention uses the detection of the onset or impending onset of a seizure to trigger sleep apnea overdrive pacing to preemptively prevent the initiation of apnea. Upon the sensing of seizure termination or a preprogrammed timeout, the sleep apnea prevention overdrive pacing is terminated/inactivated.

Alternatively, the pacing systems may begin ventricular pacing overdrive upon sensing a ventricular premature contraction to prevent the initiation of ventricular arrhythmias such as described in U.S. Pat. No. 4,503,857 "Programmable Cardiac Pacemaker with Microprocessor Control of Pacer Rate" to Boute, et al and U.S. Pat. No. 5,312,451 "Apparatus and Methods for Controlling a Cardiac Pacemaker in the Event of a Ventricular Extrasystole" to Limousin, et al. Upon detection of the onset or impending onset of a seizure ventricular extrasystole overdrive pacing may be initiated, and subsequent to the programmed number of cycles, a slowing of the ventricular rate until either the programmed base rate is reached or a sinus detection occurs. Upon the sensing of seizure termination or a preprogrammed timeout, the sleep apnea prevention overdrive pacing is terminated/inactivated.

Additionally, the pacing systems described in conjunction with FIGS. 11-25 and 41-57 may include AF preventative pacing therapies as described in U.S. Pat. No. 6,185,459 "Method and Apparatus for Prevention of Atrial Tachyarrhythmias" to Mehra, et al or U.S. Pat. No. 6,650,938 "Method and System for Preventing Atrial Fibrillation by Rapid Pacing Intervention" to Boute. The '459 and '938 patents describe systems that sense premature atrial events and initiate overdrive pacing algorithms to prevent the initiation of atrial arrhythmias. In the present invention, upon detection of the onset or impending onset of a seizure, ventricular extrasystole AF overdrive pacing may be initiated, and subsequent to the programmed number of cycles, a slowing of the ventricular rate until either the programmed base rate is reached or a sinus detection occurs. Upon the sensing

of seizure termination or a preprogrammed timeout, the sleep apnea prevention overdrive pacing is terminated/inactivated.

#### Signal Processing

The signal processing of cardiac, respiration or electroencephalogram signals of the above-described embodiments may include analog, continuous wave bandpass filtering as is well known in the art. Additionally, digital signal processing techniques as substantially described in U.S. Pat. No. 6,029,087 "Cardiac Pacing System with Improved Physiological Event Classification Based Upon DSP" to Wohlgemuth and U.S. Pat. No. 6,556,859 "System and Method for Classifying Sensed Atrial Events in a Cardiac Pacing System" to Wohlgemuth, et al may be used. Additionally, fuzzy logic processing techniques as described in U.S. Pat. No. 5,626,622 "Dual Sensor Rate Responsive Pacemaker" to Cooper and U.S. Pat. No. 5,836,988 "Rate Responsive Pacemaker with Exercise Recovery Using Minute Volume Determination" to Cooper, et al. may be used to determine/detect the occurrence or onset of seizures, respiratory or cardiac anomalies.

The devices of the above-described systems that contain 2 individual units in 2-way communication (e.g., the systems of FIG. 20-23) may optionally transmit events via the communication channel by one of several ways including, but not limited to, individual event logic signal, marker channel or processed signal.

#### Power Saving and Clock Synchronization

The devices of the above-described systems that contain 2 individual units in 2-way communication (e.g., the systems of FIG. 20-23, 45, 47-49, 51, 54, 55, 57) may optionally have a reduced power capability during communication. The devices may communicate at a predefined specific time interval with clocks in each unit of the system updated/resynchronized on each communication (as described in U.S. Pat. No. 6,083,248 "World Wide Patient Location and Data Telemetry System for Implantable Medical Devices" to Thompson. Optionally, a receiving unit may open a window at a period interval (e.g., 1 second) for a brief window (e.g., 100 mSec) to look for an incoming transmission from the other system unit.

#### Drug Pump

The therapy device in above devices as described in systems as described in conjunction with FIGS. 11-25 and 41-57 may optionally contain a drug pump to deliver liquid medicants in lieu of stimulation or in combination with stimulation. Medicants used could include epileptic drugs (examples of such drugs include, but are not limited to intrathecal delivery of CGX-1007 or Baclofen), mental health and mood disorder related drugs, cardiac drugs (examples of such drugs include, but are not limited to, pharmaceutical compositions comprising beta-adrenergic blocking agents, protein emide, type I antiarrhythmic agents such as disopyramide, class II agents such as propafenone, alphaagonists such as ephedrine and midodrine, and other antiarrhythmic agents such as amiodarone, and combinations thereof) or respiratory drugs (examples of such drugs include, but are not limited to diuretics).

#### Remote Monitoring

The present invention also allows the residential, hospital or ambulatory monitoring of at-risk patients and their implanted medical devices at any time and anywhere in the world (see system 900 FIG. 60). Medical support staff 906 at a remote medical support center 914 may interrogate and read telemetry from the implanted medical device and reprogram its operation while the patient 10 is at very remote or even unknown locations anywhere in the world. Two-way voice communications 910 via satellite 904, cellular via link 32 or land lines 956 with the patient 10 and data/programming communications with the implanted medical device 958 via a belt worn transponder 960 may be initiated by the patient 10

or the medical support staff **906**. The location of the patient **10** and the implanted medical device **958** may be determined via GPS **902** and link **908** and communicated to the medical support network in an emergency. Emergency response teams can be dispatched to the determined patient location with the necessary information to prepare for treatment and provide support after arrival on the scene. See for example, U.S. Pat. No. 5,752,976 "World Wide Patient Location and Data Telemetry System for Implantable Medical Devices" to Duffin et al.

An alternative or addition to the remote monitoring system as described above in conjunction with FIG. **60** is shown in the system **950** of FIG. **61**, which shows a patient **10** sleeping with an implantable Monitor **958** or optional therapy device as described above in connection with the systems of FIGS. **1-59**. The implantable device **958**, upon detection of a neurological event (such as a seizure), respiratory apnea or cardiac conduction anomaly (ie, heart rate variability, QT extension, arrhythmia) may alert a remote monitoring location via local remote box **952** (as described in U.S. Pat. No. 5,752,976 "World Wide Patient Location and Data Telemetry System for Implantable Medical Devices" to Duffin, et al.) telephone **954** and phone lines **956** or the patient's care provider via an RF link **32** to a pager-sized remote monitor **960** placed in other locations in the house or carried (ie, belt worn) by the care provider **962**. The remote caregiver monitor **960** may include audible buzzes/tones/beeps, vocal, light or vibration to alert the caregiver **962** of patient's monitor in an alarm/alert condition. The RF link may include RF portable phone frequencies, power line RF links, RF links using specifications such as HOMERF, BLUETOOTH, ZIGBEE, WIFI, MICS band (medical implant communications service), or any other interconnect methods as appropriate. Often the care provider **962** may be able to take some action to help the patient **10**. For example, the care provider may arouse the patient **10** from a neurological event (such as a SUDEP episode) by shaking them, arousing them, reposition the patient, or the like.

Patient Alert

The monitor (and optionally therapy) devices as described in systems described above in conjunction with FIG. **1-59** may optionally allow a patient alert to allow the patient an early warning of impending seizure, respiratory or cardiac anomalies via vibration (e.g., piezo buzzer in implanted device, a vibrator as used in a cell phone or pager in a "silent ring" mode in vest, patch or patient activator), audible buzzing or tones (e.g., audible in cranial implant, audible via external patch, patient activator or vest), light (e.g., external vest or patient activator) or vocal (e.g., spoken word in cranial, vest, external patch, or patient activator) indicators of the monitor in an alarm/alert condition.

It will be apparent from the foregoing that while particular embodiments of the invention have been illustrated and described, various modifications can be made without departing from the spirit and scope of the invention. Accordingly, it is not intended that the invention be limited, except as by the appended claims.

What is claimed is:

1. A medical device system comprising:

- a brain monitoring element for sensing activity of the brain and outputting a brain signal based upon the sensed activity of the brain;
- a cardiac monitoring element for sensing activity of the heart and outputting a cardiac signal based upon the sensed activity of the heart;
- a cardiac therapy module for providing therapeutic output to the heart; and

a processor in communication with the brain monitoring element, the cardiac monitoring element and the cardiac therapy module, the processor configured to:

- receive the cardiac signal and detect a cardiac event in the cardiac signal;

- activate the cardiac therapy module to provide the therapeutic output to the heart based on the detected cardiac event;

- determine if the detected cardiac event is categorized as a neurologically matched cardiac event, a neurologically matched cardiac event comprising a cardiac event occurring within a specified time period of one or more neurological events; and

- communicate to the cardiac therapy module to modulate the therapeutic output to the heart if the detected cardiac event is categorized as a neurologically matched cardiac event.

2. The system of claim **1** wherein a neurologically matched cardiac event comprises a cardiac event followed in time by a neurological event.

3. The system of claim **1** wherein the modulation of the therapeutic output to the heart comprises temporarily suspending cardiac therapy to the heart for a period of time and resuming cardiac therapy if the cardiac event is still present after the period of time.

4. The system of claim **3** wherein the cardiac therapy is temporarily suspended for a period of seconds.

5. The system of claim **1** wherein a neurologically matched cardiac event comprises a cardiac event having a predetermined degree of concordance to one or more neurological events.

6. The medical system according to claim **1** wherein if the detected cardiac event is of a specified nature, communicating to the therapy module to not modulate the therapeutic output to the heart, regardless of whether the detected cardiac event is a neurologically matched cardiac event.

7. The medical device system of claim **6** wherein the specified nature of the detected cardiac event is selected from the group consisting of bradycardia, asystole, tachycardia, wandering pacemaker, multifocal atrial tachycardia, atrial fibrillation, sinus pause, premature atrial contractions (PAC), ST segment elevation, ST segment depression, T-wave inversion QT interval prolongation, premature ventricular contractions (PVCs), AV-block (AVB) and bundle branch block (BBB).

8. The medical system according to claim **6** wherein the specified nature of the detected cardiac event is its duration that exceeds a predetermined threshold.

9. The medical system according to claim **6** wherein the specified nature of the detected cardiac event is its intensity that exceeds a predetermined threshold.

10. The system of claim **1** wherein the modulation of the therapeutic output to the heart comprises preventative pacing for a period of time.

11. The system of claim **10** wherein the preventative pacing comprises increased pacing rate and/or decreased pacing intensity.

12. The system of claim **11** wherein the modulation occurs for a period of seconds.

13. The system of claim **10** wherein the period of time is programmable.

14. The medical device system of claim **1** wherein the processor is further configured to

- receive the brain signal and obtain information identifying one or more neurological events in the brain signal,
- receive the cardiac signal and obtain information identifying one or more cardiac events in the cardiac signal, and

compare the brain signal to the cardiac signal, the comparing comprising determining a degree of expectancy between the one or more identified neurological events and the one or more identified cardiac events.

15. The medical device system of claim 14 wherein obtaining information identifying one or more neurological events in the brain signal comprises execution of a neurological event detection algorithm that outputs an indication that a neurological event is occurring or is not occurring based on an evaluation of the brain signal.

16. The medical device system of claim 1 further comprising a body implantable housing, the housing containing the therapy module and the processor.

17. The medical device system of claim 14 wherein the processor is further configured to obtain information categorizing each identified cardiac event as one of a first type neurologically matched cardiac event and a second type neurologically matched cardiac event.

18. The medical device system of claim 17 wherein the first type cardiac event is selected from the group consisting of bradycardia, asystole, tachyarrhythmia, atrial fibrillation, sinus pause, premature atrial contractions (PAC), ST segment elevation, ST segment depression, T-wave inversion, QT interval prolongation, premature ventricular contractions (PVCs), AV-block (AVB) and bundle branch block (BBB), and the second type cardiac event is different from the first type of cardiac event.

19. The medical device system of claim 17 wherein comparing the brain signal to the cardiac signal performed by the processor further comprises:

categorizing a first type cardiac event as a first type neurologically matched cardiac event when there is a neurological event within a specified time period after the first type cardiac event;

categorizing a second type cardiac event as second type neurologically matched cardiac event when there is a neurological event within a specified time period after the second type cardiac event; and

wherein the processor is further configured to communicate to the cardiac therapy module to modulate the therapeutic output to the heart if the detected cardiac event is categorized as a first type neurologically matched cardiac event but not as a second type neurologically matched cardiac event.

20. A method of providing cardiac therapy to the heart, the method comprising the steps of:

providing a brain monitoring element for sensing activity of the brain and outputting a brain signal based upon the sensed activity of the brain;

providing a cardiac monitoring element for sensing activity of the heart and outputting a cardiac signal based upon the sensed activity of the heart;

providing a cardiac therapy module for delivering therapeutic output to the heart; and

providing a processor in communication with the brain monitoring element, the cardiac monitoring element and the cardiac therapy module, the processor configured to: receive the cardiac signal and detect a cardiac event in the cardiac signal;

activate the cardiac therapy module to provide the therapeutic output to the heart based on the detected cardiac event;

determine if the detected cardiac event is categorized as a neurologically matched cardiac event, a neurologically matched cardiac event comprising a cardiac event occurring within a specified time period of one or more neurological events; and

communicate to the cardiac therapy module to modulate the therapeutic output to the heart if the detected cardiac event is categorized as a neurologically matched cardiac event.

21. A medical device system comprising:

a brain monitoring element for sensing activity of the brain and outputting a brain signal based upon the sensed activity of the brain;

a cardiac monitoring element for sensing activity of the heart and outputting a cardiac signal based upon the sensed activity of the heart;

a cardiac therapy module for providing therapeutic output to the heart; and

a processor in communication with the brain monitoring element, the cardiac monitoring element and the cardiac therapy module, the processor configured to:

receive the cardiac signal and detect a cardiac event in the cardiac signal;

activate the cardiac therapy module to provide the therapeutic output to the heart based on the detected cardiac event;

determine if the detected cardiac event is categorized as a neurologically matched cardiac event, a neurologically matched cardiac event comprising a cardiac event occurring within a specified time period of one or more neurological events; and

communicate to the cardiac therapy module to deliver the therapeutic output to the heart if the detected cardiac event is categorized as a neurologically matched cardiac event.

\* \* \* \* \*

专利名称(译)	利用脑状态信息调节心脏治疗的系统和方法		
公开(公告)号	<a href="#">US8214035</a>	公开(公告)日	2012-07-03
申请号	US11/796575	申请日	2007-04-27
[标]申请(专利权)人(译)	GIFTAKIS JONATHONê 格雷夫斯NINA中号 不莱梅乔纳森 品果ERIC J		
申请(专利权)人(译)	GIFTAKIS JONATHONê 格雷夫斯NINA中号 不莱梅乔纳森 品果ERIC J		
当前申请(专利权)人(译)	美敦力公司 , INC.		
[标]发明人	GIFTAKIS JONATHON E GRAVES NINA M WERDER JONATHAN C PANKEN ERIC J		
发明人	GIFTAKIS, JONATHON E. GRAVES, NINA M. WERDER, JONATHAN C. PANKEN, ERIC J.		
IPC分类号	A61N1/00 A61B5/00		
CPC分类号	A61B5/0402 A61B5/0476 A61B5/4094 A61N1/365 A61B5/0031 A61N1/37288		
优先权	60/636929 2004-12-17 US		
其他公开文献	US20070260286A1		
外部链接	<a href="#">Espacenet</a> <a href="#">USPTO</a>		

摘要(译)

一种使用脑状态信息调节或调节心脏治疗的系统。调制可以包括在一段时间内抑制标准的，规定的心脏治疗，或者它可以涉及调节所传递的心脏治疗的类型。在另一个实施例中，提供了用于确定心脏事件是否被分类为神经匹配的系统，并且如果是这样的话，调节治疗输出到心脏。

