



US009031793B2

(12) **United States Patent**
Lynn et al.

(10) **Patent No.:** US 9,031,793 B2
(45) **Date of Patent:** *May 12, 2015

(54) **CENTRALIZED HOSPITAL MONITORING SYSTEM FOR AUTOMATICALLY DETECTING UPPER AIRWAY INSTABILITY AND FOR PREVENTING AND ABORTING ADVERSE DRUG REACTIONS**

(75) Inventors: **Lawrence A. Lynn**, Columbus, OH (US); **Eric N. Lynn**, Villa Ridge, MO (US)

(73) Assignee: **Lawrence A. Lynn**, Columbus, OH (US)

(*) Notice: Subject to any disclaimer, the term of this patent is extended or adjusted under 35 U.S.C. 154(b) by 0 days.

This patent is subject to a terminal disclaimer.

4,805,623 A	2/1989	Jobis
4,807,631 A	2/1989	Hersh et al.
4,838,275 A	6/1989	Lee
4,846,195 A	7/1989	Alt
4,911,167 A	3/1990	Corenman et al.
4,913,150 A	4/1990	Cheung et al.
4,936,679 A	6/1990	Mersch
4,938,218 A	7/1990	Goodman et al.
4,971,062 A	11/1990	Hasebe et al.
4,972,331 A	11/1990	Chance
4,974,591 A	12/1990	Awazu et al.
4,995,400 A	2/1991	Boehringer et al.
5,028,787 A	7/1991	Rosenthal et al.
5,065,749 A	11/1991	Hasebe et al.
5,066,859 A	11/1991	Karkar et al.
5,072,737 A	12/1991	Goulding
5,084,327 A	1/1992	Stengel
5,092,326 A	3/1992	Winn et al.
5,094,246 A	3/1992	Rusz et al.
5,119,815 A	6/1992	Chance

(Continued)

(21) Appl. No.: **13/603,659**

(22) Filed: **Sep. 5, 2012**

(65) **Prior Publication Data**

US 2012/0330118 A1 Dec. 27, 2012

Related U.S. Application Data

(63) Continuation of application No. 11/369,355, filed on Mar. 7, 2006, which is a continuation of application No. 10/150,582, filed on May 17, 2002, now Pat. No. 7,081,095.

(60) Provisional application No. 60/291,692, filed on May 17, 2001, provisional application No. 60/291,687, filed on May 17, 2001, provisional application No. 60/295,484, filed on Jun. 1, 2001.

(51) **Int. Cl.**

G01N 33/48	(2006.01)
A61B 5/00	(2006.01)
G06F 19/00	(2011.01)

(52) **U.S. Cl.**

CPC **A61B 5/412** (2013.01); **G06F 19/3468** (2013.01); **A61B 5/4818** (2013.01); **A61B 5/002** (2013.01)

(58) **Field of Classification Search**

CPC G06F 19/3468
USPC 702/19
See application file for complete search history.

(56) **References Cited**

U.S. PATENT DOCUMENTS

3,638,640 A	2/1972	Shaw
3,646,606 A	2/1972	Buxton
3,884,219 A	5/1975	Richardson et al.
3,926,177 A	12/1975	Hardway et al.
3,999,537 A	12/1976	Noiles
4,036,211 A	7/1977	Veth et al.
4,141,354 A	2/1979	Ismach
4,202,353 A	5/1980	Hirsch et al.
4,340,044 A	7/1982	Levy et al.
4,696,307 A	9/1987	Montgieux
4,714,341 A	12/1987	Hamaguri
4,800,495 A	1/1989	Smith

FOREIGN PATENT DOCUMENTS

DE	2450900	5/1975
EP	0934723 A1	8/1988

(Continued)

OTHER PUBLICATIONS

Author Unknown, FiO2, Wikipedia Encyclopedia, modified Oct. 30, 2007 . . . <http://en.wikipedia.org/wiki/FiO2>.

Cirignotta, Fabio, Cerebral Anoxic Attacks in Sleep Apnea Syndrome, Sleep, 1989, pp. 400-404, vol. 12 No. 5.

Curry, J. Paul, Threshold Monitoring, Alarm Fatigue, and the Patterns of Unexpected Hospital Death, APSF Newsletter, Fall 2011, pp. 32-35.

Davidson Ward, Sally et al., Responses to hypoxia and hypercapnia in infants of substance-abusing mothers, The Journal of Pediatrics, 1992, pp. 704-709, vol. 121 No. 5 Pt. 1.

Diagnostic Apparatus, Bibliographic Data: JP63275325A, Publication Date Nov. 14, 1988, 12 pages.

(Continued)

Primary Examiner — Jerry Lin

(74) Attorney, Agent, or Firm — International IP Law Group, PLLC

(57) **ABSTRACT**

A system and method for the automatic diagnosis of obstructive sleep apnea in a centralized hospital critical care monitoring system for the monitoring of a plurality of patients in at least one of a critical care, step down, and cardiac ward by telemetry. The system includes a central processor having a display, and a plurality of telemetry units for mounting with patients, each of the telemetry units has a plurality of sensors for connection with each patient, the telemetry unit is capable of the transmission of multiple signals derived from the sensors to the central processor, in one preferred embodiment the method comprising steps of programming the system to analyze the signals and to automatically identify the presence and severity of obstructive sleep apnea and to provide an indication of the identification.

9 Claims, 29 Drawing Sheets

(56)

References Cited

U.S. PATENT DOCUMENTS

5,122,974 A	6/1992	Chance	6,067,462 A	5/2000	Diab et al.
5,123,420 A	6/1992	Paret	6,070,098 A	5/2000	Moore-Ede et al.
5,143,078 A	9/1992	Mather et al.	6,081,742 A	6/2000	Amano et al.
5,167,230 A	12/1992	Chance	6,083,172 A	7/2000	Baker, Jr. et al.
5,190,038 A	3/1993	Polson et al.	6,088,607 A	7/2000	Diab et al.
5,218,962 A	6/1993	Mannheimer et al.	6,095,984 A	8/2000	Amano et al.
5,238,001 A	8/1993	Gallant et al.	6,102,038 A	8/2000	DeVries
5,246,003 A	9/1993	DeLonzor	6,102,870 A	8/2000	Edwards
5,247,931 A	9/1993	Norwood	6,120,460 A	9/2000	Abreu
5,253,645 A	10/1993	Friedman et al.	6,134,460 A	10/2000	Chance
5,263,244 A	11/1993	Centa et al.	6,141,590 A	10/2000	Renirie et al.
5,269,310 A	12/1993	Jones et al.	6,150,951 A	11/2000	Olejniczak
5,279,295 A	1/1994	Martens et al.	6,151,516 A	11/2000	Kiani-Azarbayjany et al.
5,285,783 A	2/1994	Secker	6,154,667 A	11/2000	Miura et al.
5,297,548 A	3/1994	Pologe	6,163,715 A	12/2000	Larsen et al.
5,309,908 A	5/1994	Friedman et al.	6,171,258 B1	1/2001	Karakasoglu et al.
5,312,454 A	5/1994	Roline et al.	6,181,958 B1	1/2001	Steuer et al.
5,329,931 A	7/1994	Clauson et al.	6,181,959 B1	1/2001	Schollermann et al.
5,355,880 A	10/1994	Thomas et al.	6,190,324 B1	2/2001	Kieval et al.
5,372,136 A	12/1994	Steuer et al.	6,215,403 B1	4/2001	Chan et al.
5,385,143 A	1/1995	Aoyagi	6,230,035 B1	5/2001	Aoyagi et al.
5,390,666 A	2/1995	Kimm et al.	6,230,142 B1	5/2001	Benigno et al.
5,390,670 A	2/1995	Centa et al.	6,230,708 B1	5/2001	Radko
5,413,099 A	5/1995	Schmidt et al.	6,266,546 B1	7/2001	Steuer et al.
5,423,327 A	6/1995	Clauson et al.	6,285,895 B1	9/2001	Ristolainen et al.
5,469,845 A	11/1995	DeLonzor et al.	6,312,393 B1	11/2001	Abreu
5,482,036 A	1/1996	Diab et al.	6,322,515 B1	11/2001	Goor et al.
5,483,646 A	1/1996	Uchikoga	6,353,750 B1	3/2002	Kimura et al.
5,520,176 A	5/1996	Cohen	6,360,114 B1	3/2002	Diab et al.
5,553,614 A	9/1996	Chance	6,363,270 B1	3/2002	Colla et al.
5,558,086 A	9/1996	Smith et al.	6,364,834 B1	4/2002	Reuss et al.
5,564,417 A	10/1996	Chance	6,371,114 B1	4/2002	Schmidt et al.
5,575,285 A	11/1996	Takanashi et al.	6,385,589 B1	5/2002	Trusheim et al.
5,584,298 A	12/1996	Kabal	6,393,311 B1	5/2002	Edgar, Jr. et al.
5,605,151 A	2/1997	Lynn	6,397,091 B2	5/2002	Diab et al.
5,611,337 A	3/1997	Bukta	6,397,092 B1	5/2002	Norris et al.
5,619,991 A	4/1997	Sloane	6,397,099 B1	5/2002	Chance
5,630,413 A	5/1997	Thomas et al.	6,398,727 B1	6/2002	Bui et al.
5,645,059 A	7/1997	Fein et al.	6,411,833 B1	6/2002	Baker, Jr. et al.
5,645,060 A	7/1997	Yorkey	6,415,166 B1	7/2002	Van Hoy et al.
5,660,171 A	8/1997	Kimm et al.	6,415,175 B1	7/2002	Conley et al.
5,680,857 A	10/1997	Pelikan et al.	6,415,236 B2	7/2002	Kobayashi et al.
5,692,503 A	12/1997	Kuenstner	6,419,671 B1	7/2002	Lemberg
5,716,384 A	2/1998	Snell	6,425,861 B1*	7/2002	Haberland et al. 600/300
5,724,580 A	3/1998	Levin et al.	6,438,399 B1	8/2002	Kurth
5,730,124 A	3/1998	Yamauchi	6,449,501 B1	9/2002	Reuss
5,758,644 A	6/1998	Diab et al.	6,461,305 B1	10/2002	Schnall
5,769,082 A	6/1998	Perel	6,466,809 B1	10/2002	Riley
5,779,631 A	7/1998	Chance	6,475,153 B1	11/2002	Khair et al.
5,782,757 A	7/1998	Diab et al.	6,487,439 B1	11/2002	Skladnev et al.
5,786,592 A	7/1998	Hok	6,501,974 B2	12/2002	Huiku
5,800,348 A	9/1998	Kaestle	6,501,975 B2	12/2002	Diab et al.
5,822,544 A	10/1998	Chaco et al.	6,526,301 B2	2/2003	Larsen et al.
5,830,136 A	11/1998	DeLonzor et al.	6,542,764 B1	4/2003	Al-Ali et al.
5,830,139 A	11/1998	Abreu	6,544,193 B2	4/2003	Abreu
5,831,598 A	11/1998	Kauffert et al.	6,546,267 B1	4/2003	Sugiura et al.
5,840,019 A	11/1998	Wirebaugh	6,549,795 B1	4/2003	Chance
5,842,981 A	12/1998	Larsen et al.	6,553,242 B1	4/2003	Sarussi
5,846,190 A	12/1998	Woehrl	6,571,622 B2	6/2003	Koch
5,862,802 A	1/1999	Bird	6,572,557 B2	6/2003	Tchou et al.
5,871,442 A	2/1999	Madarasz et al.	6,579,242 B2	6/2003	Bui et al.
5,873,821 A	2/1999	Chance et al.	6,580,086 B1	6/2003	Schultz et al.
5,891,022 A	4/1999	Pologe	6,591,122 B2	7/2003	Schmitt
5,920,263 A	7/1999	Huttenhoff et al.	6,594,513 B1	7/2003	Jobsis et al.
5,931,790 A	8/1999	Peel, III	6,606,509 B2	8/2003	Schmitt
5,935,099 A	8/1999	Peterson et al.	6,606,511 B1	8/2003	Ali et al.
5,995,855 A	11/1999	Kiani et al.	6,615,064 B1	9/2003	Aldrich
5,995,856 A	11/1999	Mannheimer et al.	6,618,042 B1	9/2003	Powell
5,995,859 A	11/1999	Takahashi	6,622,095 B2	9/2003	Kobayashi et al.
6,002,952 A	12/1999	Diab et al.	6,641,542 B2	11/2003	Cho et al.
6,004,276 A	12/1999	Wright et al.	6,654,621 B2	11/2003	Palatnik et al.
6,011,986 A	1/2000	Diab et al.	6,654,624 B2	11/2003	Diab et al.
6,024,699 A	2/2000	Surwit et al.	6,658,276 B2	12/2003	Kianl et al.
6,050,951 A	4/2000	Friedman et al.	6,658,277 B2	12/2003	Wasserman
6,064,898 A	5/2000	Aldrich	6,659,961 B2	12/2003	Robinson
			6,662,030 B2	12/2003	Khalil et al.
			6,662,032 B1	12/2003	Gavish et al.
			6,668,183 B2	12/2003	Hicks et al.
			6,671,526 B1	12/2003	Aoyagi et al.

(56)

References Cited

U.S. PATENT DOCUMENTS

6,671,528	B2	12/2003	Steuer et al.	7,190,995	B2	3/2007	Chervin et al.
6,678,543	B2	1/2004	Diab et al.	7,209,775	B2	4/2007	Bae et al.
6,684,090	B2	1/2004	Ali et al.	7,218,966	B2	5/2007	Haefner
6,690,958	B1	2/2004	Walker et al.	7,220,220	B2	5/2007	Stubbs et al.
6,697,658	B2	2/2004	Al-Ali	7,222,623	B2	5/2007	DeVries et al.
6,699,194	B1	3/2004	Diab et al.	7,222,624	B2	5/2007	Rashad et al.
6,708,048	B1	3/2004	Chance	7,225,013	B2	5/2007	Geva et al.
6,711,424	B1	3/2004	Fine et al.	7,230,529	B2	6/2007	Ketcherside et al.
6,711,425	B1	3/2004	Reuss et al.	7,231,240	B2	6/2007	Eda et al.
6,714,245	B1	3/2004	Ono	7,236,811	B2	6/2007	Schmitt
6,721,584	B2	4/2004	Baker, Jr. et al.	7,239,905	B2	7/2007	Kiani-Azarbayjany et al.
6,723,077	B2	4/2004	Pickup et al.	7,263,395	B2	8/2007	Chan et al.
6,731,274	B2	5/2004	Powell	7,267,652	B2	9/2007	Coyle et al.
6,738,666	B1	5/2004	Park et al.	7,272,426	B2	9/2007	Schmidt et al.
6,752,150	B1	6/2004	Remmers et al.	7,277,752	B2	10/2007	Matos
6,785,568	B2	8/2004	Chance	7,297,119	B2	11/2007	Westbrook et al.
6,793,654	B2	9/2004	Lemberg	7,309,314	B2	12/2007	Grant et al.
6,801,797	B2	10/2004	Mannheimer et al.	7,338,447	B2	3/2008	Phillips
6,801,798	B2	10/2004	Geddes	7,353,054	B2	4/2008	Kawasaki et al.
6,801,799	B2	10/2004	Mendelson	7,355,512	B1	4/2008	Al-Ali
6,810,277	B2	10/2004	Edgar, Jr. et al.	7,366,569	B2	4/2008	Belalcazar
6,816,266	B2	11/2004	Varshneya et al.	7,367,339	B2	5/2008	Hickle
6,820,618	B2	11/2004	Banner et al.	7,367,954	B2	5/2008	Starr et al.
6,822,564	B2	11/2004	Al-Ali	7,370,650	B2	5/2008	Nadjafzadeh et al.
6,829,496	B2	12/2004	Nagai et al.	7,373,193	B2	5/2008	Al-Ali et al.
6,830,549	B2	12/2004	Bui et al.	7,398,115	B2	7/2008	Lynn
6,836,679	B2	12/2004	Baker, Jr. et al.	7,407,485	B2	8/2008	Huiku
6,839,581	B1	1/2005	El-Solh et al.	7,407,486	B2	8/2008	Huiku et al.
6,850,053	B2	2/2005	Daalmans et al.	7,421,296	B1	9/2008	Benser et al.
6,863,652	B2	3/2005	Huang et al.	7,431,696	B1	10/2008	Brady et al.
6,869,402	B2	3/2005	Arnold	7,447,541	B2	11/2008	Huiku et al.
6,873,865	B2	3/2005	Steuer et al.	7,460,909	B1	12/2008	Koh et al.
6,889,153	B2	5/2005	Dietiker	7,465,555	B2	12/2008	Anderson et al.
6,898,451	B2	5/2005	Wuori	7,488,293	B2	2/2009	Marcovecchio
6,918,878	B2	7/2005	Brodnick	7,499,835	B2	3/2009	Weber
6,928,370	B2	8/2005	Anuzis et al.	7,539,537	B2	5/2009	Hickle
6,931,268	B1	8/2005	Kiani-Azarbayjany et al.	7,544,190	B2	6/2009	Pickup et al.
6,931,269	B2	8/2005	Terry	7,635,337	B2	12/2009	Huika et al.
6,934,570	B2	8/2005	Kiani et al.	7,640,055	B2	12/2009	Geva et al.
6,939,307	B1	9/2005	Dunlop	7,645,573	B2	1/2010	Ivey et al.
6,947,780	B2	9/2005	Scharf	7,647,185	B2	1/2010	Tarassenko et al.
6,949,081	B1	9/2005	Chance	7,668,579	B2	2/2010	Lynn
6,961,598	B2	11/2005	Diab	7,674,230	B2	3/2010	Reisfeld
6,963,767	B2	11/2005	Rantala et al.	7,725,146	B2	5/2010	Li et al.
6,983,178	B2	1/2006	Fine et al.	7,758,503	B2	7/2010	Lynn et al.
6,985,762	B2	1/2006	Brashears et al.	7,767,395	B2	8/2010	Garrett et al.
6,993,371	B2	1/2006	Kiani et al.	7,785,262	B2	8/2010	Melker et al.
6,994,675	B2	2/2006	Sharrock	7,794,406	B2	9/2010	Reisfeld et al.
6,996,427	B2	2/2006	Ali et al.	7,803,118	B2	9/2010	Reisfeld et al.
7,013,898	B2	3/2006	Rashad et al.	7,803,119	B2	9/2010	Reisfeld
7,024,235	B2	4/2006	Melker et al.	7,806,832	B2	10/2010	Gallagher et al.
7,027,849	B2	4/2006	Al-Ali	7,970,725	B2	6/2011	Armstrong et al.
7,030,749	B2	4/2006	Al-Ali	8,274,360	B2	9/2012	Sampath et al.
7,031,857	B2	4/2006	Tarassenko et al.	8,414,488	B2	4/2013	Colman et al.
7,034,692	B2	4/2006	Hickle	8,428,966	B2	4/2013	Green, III et al.
7,035,679	B2	4/2006	Addison et al.	8,438,041	B2	5/2013	Green, III et al.
7,035,697	B1	4/2006	Brown	2001/0005773	A1	6/2001	Larsen et al.
7,040,315	B1	5/2006	Stromberg	2001/0018557	A1	8/2001	Lynn et al.
7,044,917	B2	5/2006	Arnold	2001/0020122	A1	9/2001	Steuer et al.
7,047,056	B2	5/2006	Hannula et al.	2001/0039376	A1	11/2001	Steuer et al.
7,081,095	B2	7/2006	Lynn et al.	2001/0044588	A1*	11/2001	Mault 600/549
7,090,648	B2	8/2006	Sackner et al.	2001/0044700	A1	11/2001	Kobayashi et al.
7,118,534	B2	10/2006	Ward et al.	2002/0026106	A1	2/2002	Khalil et al.
7,123,950	B2	10/2006	Mannheimer et al.	2002/0035318	A1	3/2002	Mannheimer et al.
7,127,278	B2	10/2006	Melker et al.	2002/0038079	A1	3/2002	Steuer et al.
7,130,671	B2	10/2006	Baker	2002/0042558	A1	4/2002	Mendelson
7,139,599	B2	11/2006	Terry	2002/0049389	A1	4/2002	Abreu
7,153,263	B2	12/2006	Carter et al.	2002/0062071	A1	5/2002	Diab et al.
7,161,484	B2	1/2007	Tsoukalis	2002/0082488	A1	6/2002	Al-Ali et al.
7,162,306	B2	1/2007	Caby et al.	2002/0085952	A1	7/2002	Ellingboe et al.
7,171,269	B1	1/2007	Addison et al.	2002/0091326	A1	7/2002	Hashimoto et al.
7,181,264	B2	2/2007	Wiesmann	2002/0095090	A1	7/2002	Caro et al.
7,186,217	B2	3/2007	Kawasaki	2002/0111748	A1	8/2002	Kobayashi et al.
7,188,621	B2	3/2007	DeVries et al.	2002/0128544	A1	9/2002	Diab et al.
7,190,261	B2	3/2007	Al-Ali	2002/0133068	A1	9/2002	Huiku
				2002/0138014	A1	9/2002	Baura et al.
				2002/0156354	A1	10/2002	Larson
				2002/0161287	A1	10/2002	Schmitt
				2002/0161290	A1	10/2002	Chance

(56)

References Cited

U.S. PATENT DOCUMENTS

2002/0165439	A1	11/2002	Schmitt	2006/0015021	A1	1/2006	Cheung
2002/0165462	A1	11/2002	Westbrook et al.	2006/0020181	A1	1/2006	Schmitt
2002/0198443	A1	12/2002	Ting	2006/0030763	A1	2/2006	Mannheimer et al.
2003/0023140	A1	1/2003	Chance	2006/0042631	A1	3/2006	Martin et al.
2003/0055324	A1	3/2003	Wasserman	2006/0052680	A1	3/2006	Diab
2003/0055331	A1	3/2003	Kotmel et al.	2006/0058683	A1	3/2006	Chance
2003/0060693	A1	3/2003	Monfre et al.	2006/0064024	A1	3/2006	Schnall
2003/0101076	A1	5/2003	Zaleski	2006/0081259	A1	4/2006	Bruggeman et al.
2003/0135127	A1	7/2003	Sackner et al.	2006/0084854	A1	4/2006	Cho et al.
2003/0139687	A1	7/2003	Abreu	2006/0137577	A1	6/2006	Chang et al.
2003/0144584	A1	7/2003	Mendelson	2006/0149144	A1	7/2006	Lynn et al.
2003/0150842	A1	8/2003	Mikame	2006/0155176	A1	7/2006	Ebner et al.
2003/0158466	A1	8/2003	Lynn	2006/0155206	A1	7/2006	Lynn
2003/0181815	A1	9/2003	Ebner et al.	2006/0155207	A1	7/2006	Lynn et al.
2003/0220548	A1	11/2003	Schmitt	2006/0161071	A1	7/2006	Lynn et al.
2003/0220576	A1	11/2003	Diab	2006/0167363	A1	7/2006	Osyppka et al.
2003/0228625	A1	12/2003	Toh et al.	2006/0189872	A1	8/2006	Arnold
2004/0010188	A1	1/2004	Wasserman	2006/0189880	A1	8/2006	Lynn et al.
2004/0039295	A1	2/2004	Olbrich et al.	2006/0195028	A1	8/2006	Hannula et al.
2004/0044276	A1	3/2004	Arnold	2006/0195041	A1	8/2006	Lynn et al.
2004/0054270	A1	3/2004	Pewzner et al.	2006/0195149	A1	8/2006	Hopper et al.
2004/0064020	A1	4/2004	Diab et al.	2006/0200016	A1	9/2006	Diab et al.
2004/0078219	A1	4/2004	Kaylor et al.	2006/0217614	A1	9/2006	Takala et al.
2004/0078228	A1	4/2004	Fitzgerald et al.	2006/0217615	A1	9/2006	Huiku et al.
2004/0087846	A1	5/2004	Wasserman	2006/0217628	A1	9/2006	Huiku
2004/0087916	A1	5/2004	Pickup	2006/0224058	A1	10/2006	Mannheimer
2004/0107065	A1	6/2004	Al-Ali	2006/0235324	A1	10/2006	Lynn
2004/0111014	A1	6/2004	Hickle	2006/0235726	A1	10/2006	Paraison
2004/0117204	A1	6/2004	Mazar et al.	2006/0247501	A1	11/2006	Ali
2004/0127779	A1	7/2004	Steuer et al.	2006/0258921	A1	11/2006	Addison et al.
2004/0158135	A1	8/2004	Baker, Jr. et al.	2006/0276695	A9	12/2006	Lynn et al.
2004/0163648	A1	8/2004	Burton	2006/0287590	A1	12/2006	McEowen
2004/0171920	A1	9/2004	Mannheimer et al.	2007/0004957	A1	1/2007	Hilburg
2004/0176670	A1	9/2004	Takamura et al.	2007/0010723	A1	1/2007	Utela et al.
2004/0176671	A1	9/2004	Fine et al.	2007/0015976	A1	1/2007	Miesel et al.
2004/0181134	A1	9/2004	Baker, Jr. et al.	2007/0027369	A1	2/2007	Pagnacco et al.
2004/0181196	A1	9/2004	Pickup et al.	2007/0027375	A1	2/2007	Melker et al.
2004/0204637	A1	10/2004	Diab et al.	2007/0037873	A1	2/2007	Zurier et al.
2004/0230106	A1	11/2004	Schmitt et al.	2007/0073361	A1	3/2007	Goren et al.
2004/0249299	A1	12/2004	Cobb	2007/0093701	A1	4/2007	Myers et al.
2004/0254481	A1	12/2004	Brodnick	2007/0093721	A1	4/2007	Lynn et al.
2004/0254490	A1	12/2004	Egli	2007/0129647	A1	6/2007	Lynn
2005/0001728	A1	1/2005	Appelt et al.	2007/0142719	A1	6/2007	Kawasaki et al.
2005/0017864	A1	1/2005	Tsoukalis	2007/0149860	A1	6/2007	Lynn et al.
2005/0033129	A1	2/2005	Edgar, Jr. et al.	2007/0179350	A1	8/2007	Nadeau
2005/0043616	A1	2/2005	Chinchoy	2007/0179369	A1	8/2007	Baker, Jr.
2005/0065556	A1	3/2005	Reghabi et al.	2007/0191688	A1	8/2007	Lynn
2005/0070774	A1	3/2005	Addison et al.	2007/0191697	A1	8/2007	Lynn et al.
2005/0080323	A1	4/2005	Kato	2007/0203406	A1	8/2007	Anderson et al.
2005/0085735	A1	4/2005	Baker, Jr. et al.	2007/0208269	A1	9/2007	Mumford et al.
2005/0101850	A1	5/2005	Parker	2007/0213619	A1	9/2007	Linder
2005/0113651	A1	5/2005	Wood et al.	2007/0213620	A1	9/2007	Reisfeld
2005/0113656	A1	5/2005	Chance	2007/0213621	A1	9/2007	Reisfeld et al.
2005/0113709	A1	5/2005	Millet	2007/0213622	A1	9/2007	Reisfeld
2005/0119586	A1	6/2005	Coyle et al.	2007/0213624	A1	9/2007	Reisfeld et al.
2005/0119708	A1	6/2005	Haefner	2007/0225606	A1	9/2007	Naghavi et al.
2005/0143665	A1	6/2005	Huiku et al.	2007/0225614	A1	9/2007	Naghavi et al.
2005/0154422	A1	7/2005	Band et al.	2007/0238937	A1	10/2007	Chang et al.
2005/0168722	A1	8/2005	Forstner et al.	2007/0240723	A1	10/2007	Hong et al.
2005/0177034	A1	8/2005	Beaumont	2007/0255146	A1	11/2007	Andrews et al.
2005/0187480	A1	8/2005	Kario et al.	2007/0255322	A1	11/2007	Gerber et al.
2005/0192488	A1	9/2005	Bryenton et al.	2007/0282212	A1	12/2007	Sierra et al.
2005/0192500	A1	9/2005	Caro et al.	2008/0009689	A1	1/2008	Benaron et al.
2005/0203357	A1	9/2005	Debreczeny et al.	2008/0014115	A1	1/2008	Johns
2005/0209521	A1	9/2005	Kettunen et al.	2008/0027368	A1	1/2008	Kollar et al.
2005/0222503	A1	10/2005	Dunlop et al.	2008/0036752	A1	2/2008	Diab et al.
2005/0228248	A1	10/2005	Dietiker	2008/0051764	A1	2/2008	Dent et al.
2005/0245830	A1	11/2005	Hutchinson	2008/0064965	A1	3/2008	Jay et al.
2005/0247311	A1	11/2005	Vacchiano et al.	2008/0066753	A1	3/2008	Martin et al.
2005/0251056	A1	11/2005	Gribkov et al.	2008/0082018	A1	4/2008	Sackner et al.
2005/0267346	A1	12/2005	Faber et al.	2008/0167540	A1	7/2008	Korhonen et al.
2005/0277819	A1	12/2005	Kiani et al.	2008/0177163	A1	7/2008	Wang et al.
2005/0283059	A1	12/2005	Iyer et al.	2008/0183058	A1	7/2008	Mannheimer
2006/0009688	A1	1/2006	Lamego et al.	2008/0183083	A1	7/2008	Markowitz et al.
2006/0009809	A1	1/2006	Marcovecchio et al.	2008/0188729	A1	8/2008	Sato et al.
				2008/0200775	A1	8/2008	Lynn
				2008/0200781	A1	8/2008	Van Herpen et al.
				2008/0200824	A1	8/2008	Kane et al.
				2008/0208012	A1	8/2008	Ali

(56)

References Cited

U.S. PATENT DOCUMENTS

2008/0235049 A1 9/2008 Morita et al.
 2008/0235057 A1 9/2008 Weidenhaupt et al.
 2008/0269583 A1 10/2008 Reisfeld
 2008/0269626 A1 10/2008 Gallaher et al.
 2008/0269832 A1 10/2008 Wong et al.
 2008/0275349 A1 11/2008 Halperin et al.
 2008/0281168 A1 11/2008 Gibson et al.
 2008/0287756 A1 11/2008 Lynn
 2008/0300471 A1 12/2008 Al-Ali et al.
 2008/0312533 A1 12/2008 Balberg et al.
 2009/0082641 A1 3/2009 Giftakis et al.
 2009/0083072 A1 3/2009 Osawa et al.
 2009/0143694 A1 6/2009 Krauss et al.
 2009/0177493 A1 7/2009 Narayan
 2009/0281838 A1 11/2009 Lynn et al.
 2009/0281839 A1 11/2009 Lynn et al.
 2009/0299154 A1 12/2009 Segman
 2009/0318775 A1 12/2009 Michelson et al.
 2010/0026510 A1 2/2010 Kiani et al.
 2010/0066540 A1 3/2010 Theobald et al.
 2010/0079292 A1 4/2010 Lynn et al.
 2010/0088346 A1 4/2010 Urness et al.
 2010/0113909 A1 5/2010 Batchelder et al.
 2010/0234705 A1 9/2010 Lynn
 2010/0261977 A1 10/2010 Seely
 2011/0009722 A1 1/2011 Amundson et al.
 2011/0015501 A1 1/2011 Lynn et al.
 2011/0208018 A1 8/2011 Kiani
 2011/0208539 A1 8/2011 Lynn
 2012/0145152 A1 6/2012 Lain et al.
 2012/0328594 A1 12/2012 McKenna et al.
 2013/0211214 A1 8/2013 Olsen
 2013/0254717 A1 9/2013 Al-Ali et al.
 2013/0262730 A1 10/2013 Al-Ali et al.
 2013/0274572 A1 10/2013 Al-Ali et al.
 2013/0276785 A1 10/2013 Melker

FOREIGN PATENT DOCUMENTS

EP 0459647 B1 10/1991
 EP 0459284 A1 12/1991
 EP 0615723 3/1993
 EP 0666056 A1 7/1994
 EP 0392503 B1 5/1995
 EP 0684011 A1 5/1995
 EP 0700690 A2 3/1996
 EP 0759791 A1 3/1997
 EP 0875258 A2 11/1998
 EP 1172123 A2 1/2002
 EP 1905356 9/2007
 GB 1554829 2/1978
 JP 63275325 11/1988
 JP 05266002 3/1992
 JP 2000-042111 2/2000
 JP 2004145853 5/2004
 JP 2005034472 2/2005
 JP 2006519626 8/2006
 WO WO 92/12750 8/1992
 WO WO 93/16629 9/1993
 WO WO 96/39927 12/1996
 WO WO 97/19719 6/1997
 WO WO 98/43071 A1 10/1998
 WO WO 99/13766 3/1999
 WO WO 00/21438 4/2000
 WO WO 01/40776 6/2001
 WO WO 01/76461 10/2001
 WO WO 01/76471 10/2001
 WO WO 01/87149 11/2001
 WO WO 02/41771 A1 5/2002
 WO WO 03/039326 5/2003
 WO WO 03/053780 7/2003
 WO WO 2004056301 A2 7/2004
 WO WO 2004080300 A1 9/2004
 WO WO 2005/037077 4/2005

WO WO 2005/056087 A1 6/2005
 WO WO 2005/065540 A1 7/2005
 WO WO 2006/086010 A2 8/2006
 WO WO 2006/116469 A2 11/2006
 WO WO 2007/013708 2/2007
 WO WO 2007/131064 11/2007
 WO WO 2007/131066 11/2007
 WO WO 2008/008163 A2 1/2008

OTHER PUBLICATIONS

Doherty, L. S et al., Long-term effects of nasal continuous positive airway pressure therapy on cardiovascular outcomes in sleep apnea syndrome, *Chest*, Jun. 2005, vol. 127, No. 6, pp. 2076-2084 (Abstract).
 Horne, Rosemary S.C. et al., Arousal responses and risk factors for sudden infant death syndrome, *Sleep Medicine* 3, 2002, Supplement, pp. S61-S65.
 Horne, Rosemary S.C. et al., Effects of Prematurity on Arousal from Sleep in the Newborn Infant, *Pediatric Research*, 2000, pp. 468-474, vol. 47 No. 4.
 Intensive Care Ventilators, Product Comparison by Healthcare Product Comparison Systems, Inc. published by ECRI, Apr. 2006, 71 pages.
 International Application No. PCT/US2009/059102, Written Opinion of the International Searching Authority, date of Issue Apr. 5, 2011.
 Lung Volumes, Wikipedia, available at http://en.wikipedia.org/wiki/Tidal_volume, printed on Nov. 15, 2007, 4 pages.
 McEwen, James et al., Detection of Interruptions in the Breathing Gas of Ventilated Anaesthetized Patients, *Canadian Journal of Anaesthesiology*, 1988, vol. 35, No. 6, pp. 549-561.
 Newman, N. M., Arousal defect: Mechanism of the Sudden Infant Death Syndrome?, *Australian Pediatric Journal*, 1989, pp. 196-201.
 Rivera, Luis, MD et al., Dynamic Ventilatory Characteristics During Weaning in Postoperative Critically Ill Patients, *Anesthesia & Analgesia*, 1997, vol. 84, pp. 1250-1255.
 Stacey, Michael et al., "Temporal abstraction in the intelligent clinical data analysis: A survey," *Artificial Intelligence in Medicine*, 2007, vol. 19, pp. 1-24.
 Abelson, Harold et al., *Structure and Interpretation of Computer Programs*, MIT Press, 2nd Edition, 1996, p. 99-107, 113-126.
 Agronsky, Dominik, et al., Diagnosing Community-Acquired Pneumonia with a Bayesian Network, *AMIA, Inc.*, 1998, pp. 632-636.
 Appeal Brief for U.S. Appl. No. 11/351,961, filed Sep. 24, 2009.
 Brabrand, Mikkel, et al., Risk scoring systems for adults admitted to the emergency department: a systematic review, *Scandinavian Journal of Trauma, Resuscitation & Emergency Medicine*, Retrieved from <<http://www.sjtrem.com/content/18/1/8>>, 2010, pp. 1-8.
 Caines et al: "Overlooking orthostatic hypotension with routine blood-pressure equipment" *1 Lancet the Lancet Limited. London, GB*, vol. 352, No. 9126, Aug. 8, 1998, p. 458, DXP004832973, ISSN:0140-6736, the whole document.
 Capuano, Terry Ann, et al., *Remote Telemetry, Nursing Management*, Vo. 26, No. 7, Jul. 1995, p. 26.
 Charbonnier et al., "A trend-based alarm system to improve patient monitoring in intensive care units," *Control Engineering Practice*, Pergamon Press, Oxford, GB, vol. 15, No. 9, May 12, 2007; pp. 1039-1050.
 Crowe, Colleen A., et al., Comparison of severity of illness scoring systems in the prediction of hospital mortality in severe sepsis and septic shock, *Journal of Emergencies, Trauma, and Shock*, Oct.-Dec. 2010, pp. 342-347, Oak Lawn, IL, USA.
 Diep, Binh An, et al., Polymorphonuclear leukocytes mediate *Staphylococcus aureus* Panton-Valentine leukocidin-induced lung inflammation and injury, *PNAS*, Mar. 23, 2010, vol. 107, No. 12, pp. 5587-5592.
 Doctors use 'remote control' to monitor ICU patients, *CNN.com. technology>computing*, Aug. 21, 2000, http://www.cnn.com/2000/TECH/computing/08/21/icu.t_t1.
 Earthrowl-Gould, T., et al.; "Chest and abdominal surface motion measurement for continuous monitoring of respiratory function," *Proc. Instn Mech Engrs*, V215, Part H; pp. 515-520 (2001).

(56)

References Cited

OTHER PUBLICATIONS

- East, Christine E., et al.; "Fetal Oxygen Saturation and Uterine Contractions During Labor," American Journal of Perinatology, vol. 15, No. 6, pp. 345-349 (Jun. 1998).
- Examiner's Answer for U.S. Appl. No. 11/351,961, mailed Jan. 4, 2010.
- Ferrari, A U, et al., Inverse Relationship between heart rate and blood pressure variabilities in rats. Hypertension. Nov. 1987, vol. 10, No. 5, pp. 533-537.
- Final Office Action for U.S. Appl. No. 11/351,961, mailed Apr. 24, 2009.
- Finding Value in Intensive Care, From Afar, The New York Times on the Web, Jul. 27, 1999, www.Visicu.com/ companynews/0799_nytimes.htm.
- Fry, Donald, et al., The Changing Face of *Staphylococcus aureus*: A Continuing Surgical Challenge, Surgical Infections, 2011, vol. 12, No. 3, pp. 191-203.
- Ghanem-Zoubi, Nesrin, et al., Assessment of disease-severity scoring systems for patients with sepsis in general internal medicine departments, Critical Care, Retrieved from <http://ccforum.com/content/15/2/R95>, 2011, pp. 1-7.
- Grundy, Betty L., et al., Telemedicine in Critical Care: An Experiment in Health Care Delivery, JACEP, vol. 6, Oct. 1977, pp. 439-444.
- Hornero, Roberto, et al.; "Utility of Approximate Entropy From Overnight Pulse Oximetry Data in the Diagnosis of the Obstructive Sleep Apnea Syndrome," IEEE Transactions on Biomedical Engineering, vol. 54, No. 1, pp. 107-113, Jan. 2007.
- International Preliminary Report on Patentability Including Written Opinion for International (PCT) Patent Application No. PCT/US2009/043150, issued Nov. 9, 2010 9 pages.
- International Preliminary Report on Patentability including Written Opinion for International (PCT) Patent Application No. PCT/US2009/064312, issued May 31, 2011 10 pages.
- International Search Report and Written Opinion for application No. PCT/GB2010/001624 dated Dec. 7, 2010.
- International Search Report for International (PCT) Patent Application No. PCT/US2009/043150, mailed Aug. 4, 2009 2 pages.
- International Search Report for International (PCT) Patent Application No. PCT/US2009/064312, mailed Feb. 26, 2010 3 pages.
- International Search Report for International (PCT) Patent Application No. PCT/US2012/065124, mailed Mar. 25, 2013, 10 pages.
- International Search Report for International (PCT) Patent Application No. PCT/US2012/065129, mailed Mar. 20, 2013, 12 pages.
- International Search Report, PCT/US2008/002253; Date of mailing: Jun. 9, 2008.
- International Search Report, PCT/US2008/002254, Date of Mailing: Jul. 28, 2008.
- Johansson, A.; "Neural network for photoplethysmographic respiratory rate monitoring," Medical & Biological Engineering & Computing, vol. 41, pp. 242-248 (2003).
- Johnston, W.S., et al.; "Extracting Breathing Rate information from a Wearable Reflectance Pulse Oximeter Sensor," Proceedings of the 26th Annual International conference of the IEEE EMBS, San Francisco, California; Sep. 1-5, 2004; pp. 5388-5391.
- Kaplan, Simon M. and Geraldine Fitzpatrick, Designing Support for Remote Intensive-Care Telehealth Using the Locales Framework, ACM, 1997, pp. 173-184.
- Kellett, J., et al., The Simple Clinical Score predicts mortality for 30 days after admission to an acute medical unit, Retrieved from <http://qjmed.oxfordjournals.org>, Q J Med, Received Apr. 17, 2006 and in revised form Jul. 3, 2006, pp. 771-781, vol. 99, Published by Oxford University Press on behalf of the Association of Physicians, Nenagh, Ireland.
- Kreisel, Kristen, et al., USA300 Methicillin-resistant *Staphylococcus aureus* bacteremia and the risk of severe sepsis: is USA300 Methicillin-resistant *Staphylococcus aureus* associated with more severe infections?, Diagnostic Microbiology and Infectious Disease, 2011, vol. 70, pp. 285-290.
- Lappin, Emma, et al., Gram-Positive Toxic Shock Syndromes, The Lancet, May 2009, vol. 9, pp. 281-290.
- Lee, Ho Sung, et al., Remote Patient Monitoring Service through World-Wide Web, Proceedings—19th International Conference—IEEE/EMBS, Oct. 3D-Nov. 2, 1997, pp. 928-931.
- Levy, Mitchell M., et al., 2001 SCCM/ESICM/ACCP/ATS/SIS International Sepsis Definitions Conference, Critical Care Medicine, 2003, pp. 1250-1256, vol. 31 No. 4.
- Mabry, Susan L., et al., Integrated Medical Analysis System, Proceedings of the 1997 Winter Simulation Conference, , 1997, pp. 1167-1168.
- Maletras, Francois-Xavier, et al.; "Construction and calibration of a new design of Fiber Optic Respiratory Plethysmograph (FORP)," Optomechanical Design and Engineering, Proceedings of SPIE, vol. 4444, pp. 285-293 (2001).
- Members of the American College of Chest Physicians/Society of Critical Care Medicine Consensus Conference Committee, Definitions for sepsis and organ failure and guidelines for the use of innovative therapies in sepsis, Critical Care Medicine, 1992, pp. 864-874, vol. 20 No. 6.
- Miksch, Silvia, Artificial Intelligence for Decision Support: Needs, Possibilities, and Limitations in ICU, 10th Postgraduate Course in Critical Care Medicine A.P.I.C.E. '95, Springer, 1995, pp. 1-11.
- Nenov, Valeriy and John Klopp, Remote Access to Neurosurgical CU Physiological Data using the World Wide web, health Care in the Information Age, 1996, pp. 242-249.
- Nguyen, H. Bryant, et al., Severe Sepsis and Septic Shock: Review of the Literature and Emergency Department Management Guidelines, Annals of Emergency Medicine, Jul. 2006, vol. 48, No. 1, pp. 28-55.
- Nilsson, Lena, et al.; "Monitoring of Respiratory Rate in Postoperative Care Using a New Photoplethysmographic Technique," Journal of Clinical Monitoring and Computing, vol. 16, pp. 309-315 (2000).
- Non-Final Office Action for U.S. Appl. No. 11/351,961, mailed Aug. 19, 2008.
- Notice of Allowability for U.S. Appl. No. 10/150,582, mailed Feb. 13, 2006.
- Notice of Allowance for U.S. Appl. No. 11/455,408, mailed Jan. 23, 2012 8 pages.
- Notice of Allowance for U.S. Appl. No. 11/455,488, mailed Aug. 22, 2011 8 pages.
- Notice of Allowance for U.S. Appl. No. 11/455,488, mailed Nov. 29, 2011 8 pages.
- Official Action for Canada Patent Application No. 2,678, 776, dated Feb. 8, 2012.
- Official Action for Canada Patent Application No. 2,678,856, mailed Feb. 2, 2012 3 pages.
- Official Action for U.S. Appl. No. 10/150,582, mailed Jun. 20, 2005.
- Official Action for U.S. Appl. No. 11/274,960, mailed Jun. 8, 2010.
- Official Action for U.S. Appl. No. 11/274,960, mailed Oct. 20, 2010.
- Official Action for U.S. Appl. No. 11/280,559, mailed Mar. 21, 2011 13 pages.
- Official Action for U.S. Appl. No. 11/280,559, mailed Oct. 5, 2011 12 pages.
- Official Action for U.S. Appl. No. 11/280,653, mailed Dec. 1, 2010 9 pages.
- Official Action for U.S. Appl. No. 11/280,653, mailed Jun. 13, 2011 8 pages.
- Official Action for U.S. Appl. No. 11/280,653, mailed Mar. 31, 2010.
- Official Action for U.S. Appl. No. 11/351,787, mailed Apr. 22, 2011 11 pages.
- Official Action for U.S. Appl. No. 11/351,787, mailed Nov. 12, 2010.
- Official Action for U.S. Appl. No. 11/351,961, mailed Apr. 24, 2009.
- Official Action for U.S. Appl. No. 11/351,961, mailed Aug. 19, 2008.
- Official Action for U.S. Appl. No. 11/351,961, mailed Jan. 4, 2010.
- Official Action for U.S. Appl. No. 11/369,355, mailed Aug. 18, 2011 8 pages Restriction Requirement.
- Official Action for U.S. Appl. No. 11/369,355, mailed Jan. 6, 2012 8 pages.
- Official Action for U.S. Appl. No. 11/369,379, mailed Jun. 20, 2011 8 pages.
- Official Action for U.S. Appl. No. 11/455,408, mailed Dec. 27, 2010.
- Official Action for U.S. Appl. No. 11/455,408, mailed Jul. 27, 2011 6 pages.
- Official Action for U.S. Appl. No. 11/455,488, mailed Dec. 28, 2010.

(56)

References Cited

OTHER PUBLICATIONS

- Official Action for U.S. Appl. No. 12/437,385, mailed Apr. 5, 2011 22 pages.
- Official Action for U.S. Appl. No. 12/437,385, mailed Nov. 25, 2011 18 pages.
- Official Action for U.S. Appl. No. 12/437,417, mailed Mar. 4, 2011 24 pages.
- Official Action for U.S. Appl. No. 12/839,177, mailed Nov. 21, 2011 12 pages.
- Patel, M.S., et al., Does the use of a "track and trigger" warning system reduce mortality in trauma patients?, *Injury*, D May 25, 2011, doi:10.1016/j.injury.2011.05.030, pp. 1-5, Elsevier Ltd., United Kingdom.
- Perednia, Douglas A., *Telemedicine Technology and Clinical Applications*, JAMA, vol. 6, Feb. 8, 1995, p. 483.
- Pickett, John, et al.; "Pulse Oximetry and PPG Measurements in Plastic Surgery," *Proceedings—19th International Conference—IEEE/EMBS*, Chicago, Illinois, Oct. 30-Nov. 2, 1997, pp. 2330-2332.
- Remote Monitoring of ICU Patients Lowers Mortality Rates, Complications, Johns Hopkins Newsrelease, Mar. 20, 2001, <http://www.newswise.com/articles/2001/3/ICU.JHM.html>.
- Response to Non-Final Office Action for U.S. Appl. No. 11/351,961, filed Dec. 19, 2008.
- Restriction Requirement for U.S. Appl. No. 11/369,355, mailed Sep. 2, 2010.
- Restriction Requirement for U.S. Appl. No. 11/274,960, mailed Feb. 3, 2010.
- Restriction Requirement for U.S. Appl. No. 11/280,559, mailed Mar. 4, 2010.
- Restriction Requirement for U.S. Appl. No. 11/280,559, mailed Oct. 18, 2010.
- Restriction Requirement for U.S. Appl. No. 11/351,787, mailed Jul. 9, 2010.
- Restriction Requirement for U.S. Appl. No. 11/369,355, mailed Dec. 8, 2010.
- Restriction Requirement for U.S. Appl. No. 11/369,379, mailed Dec. 27, 2010.
- Restriction Requirement for U.S. Appl. No. 11/369,379, mailed Sep. 20, 2010.
- Restriction Requirement for U.S. Appl. No. 11/455,408, mailed Sep. 30, 2010.
- Restriction Requirement for U.S. Appl. No. 11/455,488, mailed Sep. 16, 2010.
- Rosenfeld, M.D., Brian A., FCCM, FCCP, et al., Intensive care unit telemedicine: Alternate paradigm for providing continuous intensive care, *Critical Care Medicine*, vol. 28, No. 12, 2000 p. 3925.
- Sawyer, Amber M., et al., Implementation of a real-time computerized sepsis alert in no intensive care unit patients, *Critical Care Medicine*, 2011, pp. 469-473, vol. 39, No. 3 D.
- Seelbach-Gobel, Birgit, et al.; The prediction of fetal acidosis by means of intrapartum fetal pulse oximetry, *Am J Obstet. Gynecol.*, vol. 180, No. 1, Part 1, pp. 73-81 (1999).
- Seigel, Todd A., et al., Inadequacy of Temperature and White Blood Cell Count in Predicting Bacteremia in Patients D with Suspected Infection, 2010, Elsevier, Inc., *The Journal of Emergency Medicine*, pp. 1-6, 2010.
- Spigulis, Janis, et al.; "Optical multi-channel sensing of skin blood pulsations." *Optical Sensing*, *Proceedings of SPIE*, vol. 5459, pp. 46-53 (2004).
- Subbe, C. P., et al., Validation of a modified Early Warning Score in medical admissions, *Original Papers*, *Q J Med*, D May 17, 2001 and in revised form Jul. 9, 2001, pp. 521-526, vol. 94, *Association of Physicians*.
- Tufte, Edward R., *The Visual Display of Quantitative Information* (Graphics Press, 1983), p. 17, 21, 153.
- U.S. Appl. No. 11/431,686, Amendment and Response to NF Office Action, filed Jun. 21, 2011.
- U.S. Appl. No. 11/431,686, Final Office Action, dated Oct. 12, 2011.
- U.S. Appl. No. 11/431,686, NF Office Action, dated Jan. 21, 2011.
- U.S. Appl. No. 11/431,686, Office Action (Restriction Requirement), dated Sep. 30, 2010.
- U.S. Appl. No. 11/431,686, Request for Continued Examination and Preliminary Amendment, filed Feb. 29, 2012.
- U.S. Appl. No. 11/431,686, Response to Restriction Requirement, filed Oct. 29, 2010.
- U.S. Appl. No. 12/437,385, Amendment and Response to NF Office Action, dated Jan. 15, 2013.
- U.S. Appl. No. 12/437,385, Amendment and Response to NF Office Action, dated Sep. 6, 2011.
- U.S. Appl. No. 12/437,385, Final Office Action, dated Nov. 25, 2011.
- U.S. Appl. No. 12/437,385, NF Office Action, dated Apr. 5, 2011.
- U.S. Appl. No. 12/437,385, NF Office Action, dated Aug. 17, 2012.
- U.S. Appl. No. 12/437,385, Request for Continued Examination and Preliminary Amendment, filed Feb. 7, 2012.
- U.S. Appl. No. 12/437,417, Amendment and Response to NF Office Action, dated Nov. 5, 2012.
- U.S. Appl. No. 12/437,417, Amendment and Response to NF Office Action, dated Sep. 6, 2011, 13 pages.
- U.S. Appl. No. 12/437,417, Final Office Action, dated Feb. 14, 2013.
- U.S. Appl. No. 12/437,417, NF Office Action, dated Aug. 3, 2012.
- U.S. Appl. No. 12/437,417, Final Office Action, dated Nov. 29, 2011.
- U.S. Appl. No. 12/437,417, Request for Continued Examination and Preliminary Amendment, filed Feb. 29, 2012.
- U.S. Appl. No. 12/629,407, Amendment and Response to NF Office Action dated Sep. 25, 2012, filed Feb. 21, 2013.
- U.S. Appl. No. 12/629,407, NF Office Action, dated Aug. 16, 2012.
- U.S. Appl. No. 12/629,407, NF Office Action, dated Sep. 25, 2012.
- U.S. Appl. No. 12/629,407, Response to Requirement for Restriction, filed Sep. 14, 2012.
- Wile, Michael J., et al., *Manual Differential Cell Counts Help Predict Bacterial Infection, a Multivariate Analysis*, *D Hematopathology*, 2001, pp. 644-649, vol. 115, *Am J Clin Pathol*.
- Yoon, Gilwon, et al.; Multiple diagnosis based on Photo-plethysmography: hematocrit, SpO₂, pulse and respiration, *Optics in Health Care and Biomedical optics: Diagnostics and Treatment*, *Proceedings of the SPIE*, vol. 4916; pp. 185-188 (2002).
- Alaris System, Brochure, Medication Safety System Focused at the Point of Care, Cardinal Health, Alaris Products, pp. 8, 2004.
- Alian, Aymen et al., Evaluation of Rapid Response Team Flag-Alert Parameters, Published on www.cardiopulmonarycorp.com/pdf/rapidresponsealert_paramers.pdf referenced in 2008, Internet Publication 2010.
- Author Unknown, Chapter IV Oxygen Consumption During ADO, Introduction, pp. 40-46, Book Title Unknown, Study published 1980.
- Author Unknown, Chapter X Effects of a 6-minute Period of ADO, Introduction, pp. 108-113, Book Title Unknown, Study published 1980.
- Author Unknown, Hospital Inpatient Chart, Completed prior to 2011, not published.
- Avance Innovating with you, shaping exceptional care, Brochure, GE Healthcare, pp. 8, 2006.
- Bartolo, Anton et al., An Arrhythmia Detector and Heart Rate Estimator for Overnight Polysomnography Studies, conditionally accepted for *IEEE Transactions*, 19 pages, Nov. 3, 2000.
- Benumof, Jonathan L., Creation of Observational Unit May Decrease Sleep Apnea Risk, Letters to the Editor, *Anesthesia Patient Safety Foundation Newsletter* and posted on the Malpractice company's web site. The Doctors Company I Sleep Apnea and Narcotic Postoperative Pain . . . <http://www.thedoctors.com/risk/bulletins/sleepapnea.asp>, 2002: 17:39.
- Buckle, Patricia et al., Polysomnography in Acutely Ill Intensive Care Unit Patients, *Chest*, v. 102 n. 1, p. 288 (4), *American College of Chest Physicians*, Jul. 1992.
- Centiva/5 Critical Care Ventilator, Brochure, GE Healthcare, pp. 8, Oct. 2005.
- Chi, Time-Series Matrices, University of Minnesota, <http://www-users.cs.umn.edu/~echi/papers/infovis97/sread/node13.html>, 1997, pp. 1-3.
- Critical Care Therapy and Respiratory Care Section Policy, National Institute of Health, pp. 7, revised Mar. 2000.
- Daley, Denise M., MD, Beware of All Sedatives in Patients With Sleep Apnea, *Anesthesia Patient Safety Foundation Newsletter* and

(56)

References Cited

OTHER PUBLICATIONS

posted on the Malpractice company's web site. The Doctors Company, Sleep Apnea and Narcotic Postoperative Pain . . . <http://www.thedoctors.com/risk/bulletins/sleepapnea.asp>, Letters to the Editor 2002-2003.

Datex-Phmeda Output Protocols Ohmeda Corn 1.0 Serial Protocol, Brochure, Datex-Ohmeda, Version 1.5, pp. 31. Aug. 14, 2001.

Dempsey, Jerome A. et al., Sleep and Breathing State of the Art Review Sleep-Induced Breathing Instability, *Sleep*, vol. 19, No. 3, pp. 236-247, American Sleep Disorders Association and Sleep Research Society, 1996.

Ferber, Richard et al., Portable Recording in the Assessment of Obstructive Sleep Apnea, ASDA Standards of Practice, American Sleep Disorders Association, vol. 17, No. 4, pp. 378-392, 1610 14th Street, NW, Suite 300, Rochester, MN 55901-2200, USA, 1994.

Fisher, Kyle S., MD, Value of Pulse Oximetry Monitoring on the Ward is Questioned, Anesthesia Patient Safety Foundation Newsletter and posted on the Malpractice company's web site. The Doctors Company | Sleep Apnea and Narcotic Postoperative Pain . . . <http://www.thedoctors.com/risk/bulletins/sleepapnea.asp>, Fall 2002.

Henderson, L. J. et al., Blood as a Physicochemical System. II, pp. 426-431, Paper, 1924.

Jain, Sanjay S. et al., Perioperative Treatment of Patients with Obstructive Sleep Apnea, *Current Opinion Pulmonary Medicine* 10, pp. 482-488, 2004.

Kaplan, Joseph et al., Home Pulse Oximetry as a Screening Test for Sleep-Disordered Breathing, *Chest*, vol. 103, pp. 322S, Northbrook, IL, USA, 1993.

Lynn, Lawrence, Background of Oximetry Utilization for Sleep Apnea Diagnosis, Publication information unknown, Article Written 1994, Not published.

Lynn, Lawrence A. et al., History of Threshold Oximetry, First viewing of Article Apr. 11, 2009, not published.

Lynn, Lawrence A. et al., Piercing the Panacea of Pulse Oximetry, Article Written Jul. 24, 2006, 8 pages, Not published.

Lynn, Lawrence, The Physiologic Parameters Defining the Oximetry Waveform Patterns in Sleep Apnea, Article Written 1994, Not published.

Lynn, Lawrence et al., Patterns of Unexpected In-Hospital Deaths: A Root Cause Analysis, *Patient Safety in Surgery*, vol. 5, No. 3, pp. 1-25, Feb. 11, 2011.

Final Official Action for U.S. Appl. No. 12/629,407, mailed Jul. 17, 2013 14 pages.

Final Office Action for U.S. Appl. No. 13/603,659, dated Sep. 25, 2013, 8 pages, English.

Non-Final Official Action for U.S. Appl. No. 11/369,355, dated Sep. 17, 2013 8 pages, English.

Patil, Ramesh S. et al., Application of an Artificial Intelligence Program to Therapy of High Risk Surgical Patients, *New Horizons*, vol. 4, No. 4, pp. 541-550, 1996.

Redline, Susan et al., Hypopnea, a Floating Metric: Implications for Prevalence, Morbidity Estimates, and Case Finding, *Sleep*, vol. 20, No. 12, pp. 1209-1217, 1997.

Ruchala, Joanna B., Chapter 13, Applications of Pulse Oximetry, *Book: Design of Pulse Oximeters*, pp. 214-236, Oct. 1997.

Sadeh, Avi et al., The Role of Actigraphy in the Evaluation of Sleep Disorders, an American Sleep Disorders Association and Sleep Research Society, *Sleep*, vol. 18, No. 4, pp. 288-302, 1995.

Scharf, Steven M. et al., Cardiovascular Effects of Periodic Occlusions of the Upper Airways in Dogs, *American Review of Respiratory Disease*, pp. 321-329, Aug. 1992.

Shneerson J, Obstructive Sleep Apnoea, *BMJ*, pp. 315-367 (Aug. 9, 1997); <http://bmj.com/Shneerson> et al. (7104).

Siggaard-Anderson, O et al., Editorial: The Bohr Effect and the Haldane Effect, Publication information unknown, 1973.

Strohl, Kingman P. et al., Physiologic Basis of Therapy for Sleep Apnea, State of Art: Physiologic Basis of Therapy for Sleep Apnea, pp. 791-802, 1986.

Tatevossian, Raymond G. et al. Noninvasive Hemodynamic Monitoring for Early Warning of Adult Respiratory Distress Syndrome in Trauma Patients, *Journal of Critical Care*, vol. 15, No. 4 (Dec.), 2000, pp. 151-159.

Thorpy, Michael et al., ASDA Standards of Practice, Practice Parameters for the Use of Portable Recording in the Assessment of Obstructive Sleep Apnea, Standards of Practice Committee of the American Sleep Disorders Associate, *Sleep*, vol. 17, No. 4, pp. 372-377, 1994.

Wilkins, Robert L. et al., Egan's Fundamentals of Respiratory Care, Analysis and Monitoring of Gas Exchange, Book, Eighth Edition, Chapter 16, Section III, Capnography/Capnometry During Mechanical Ventilation, pp. 383-389, 2003.

Williams et al., Screening for Sleep Apnea Using Pulse Oximetry and a Clinical Score, *Chest*, 100/3, Sep. 1991, pp. 631-635.

Campbell, Beverly, Arterial Waveforms: Monitoring Changes in Configuration, *Hemodynamics, Heart & Lung*, May/Jun. 1997, vol. 26, No. 3, pp. 204-214.

* cited by examiner

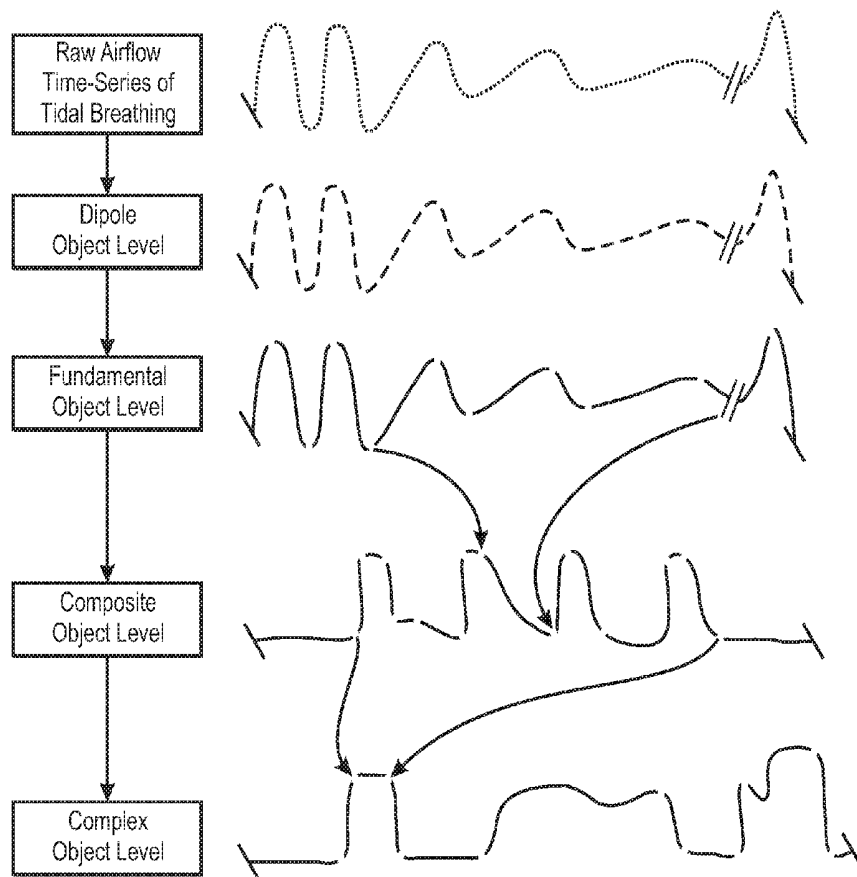

FIG. 2

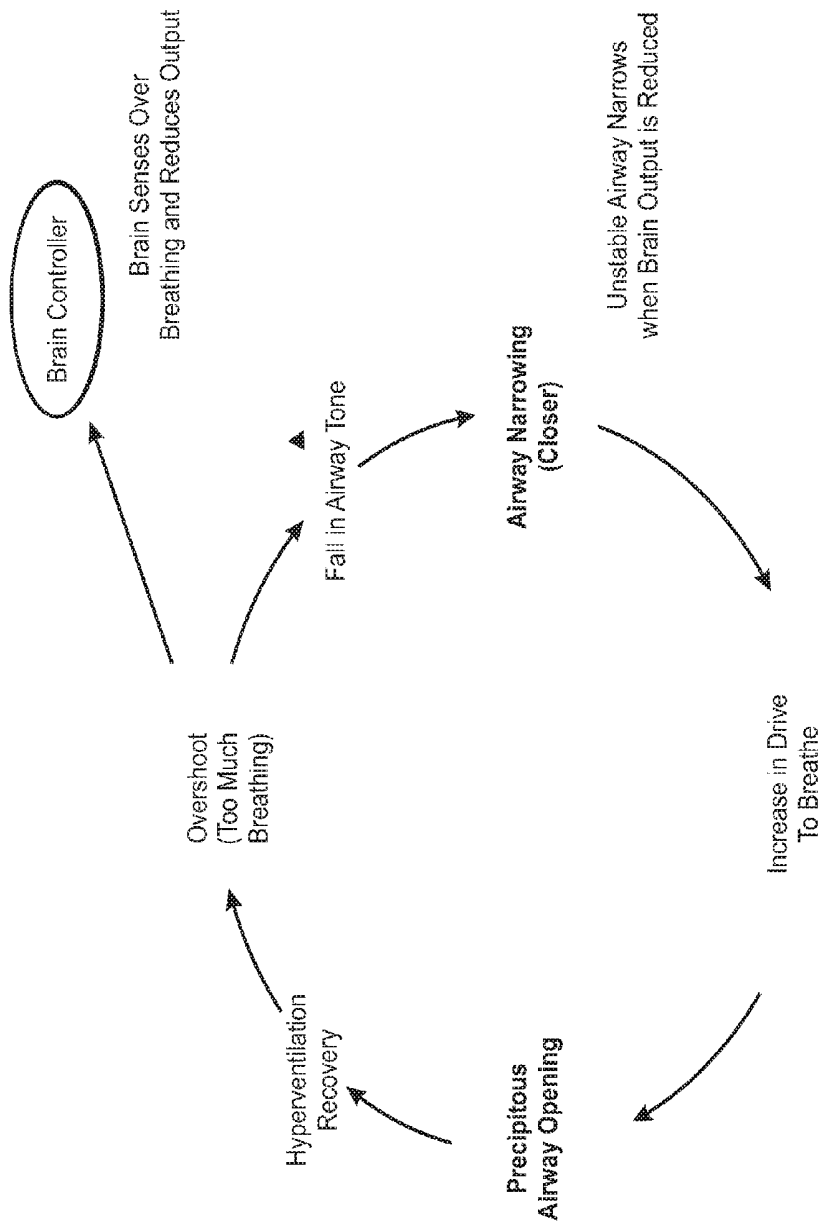

FIG. 3A

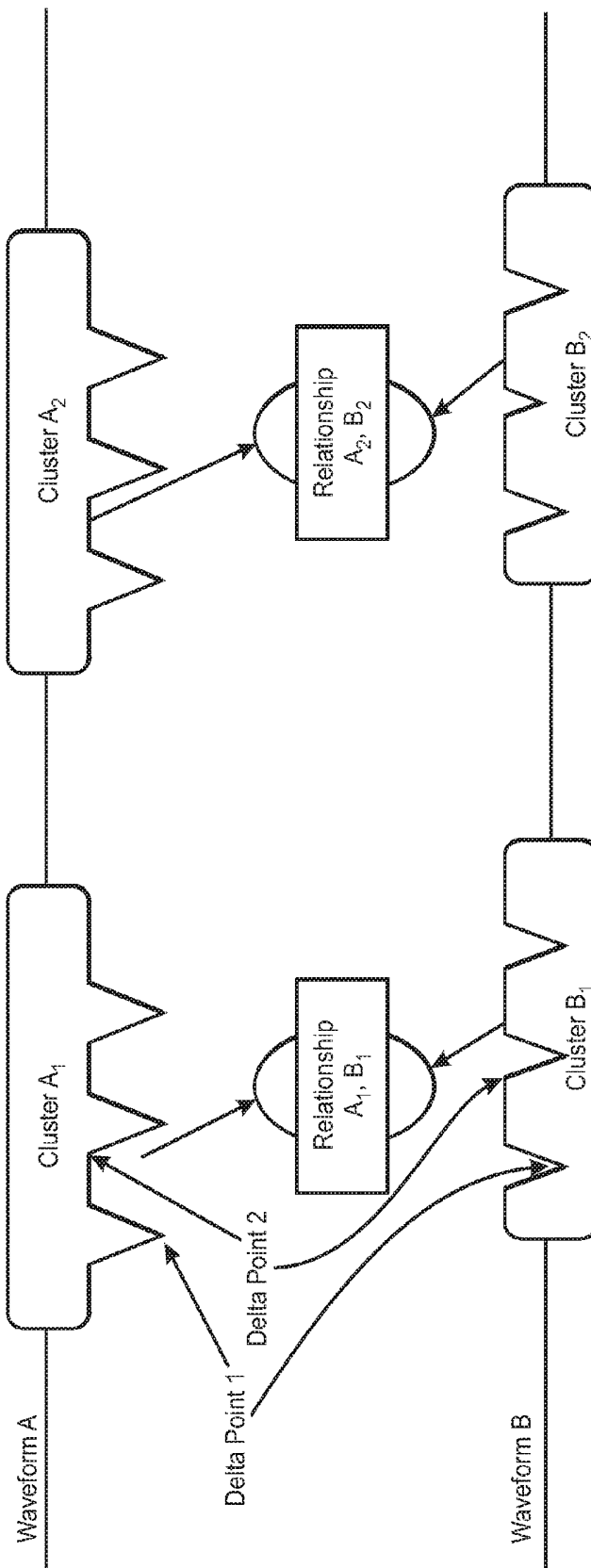

FIG. 3B

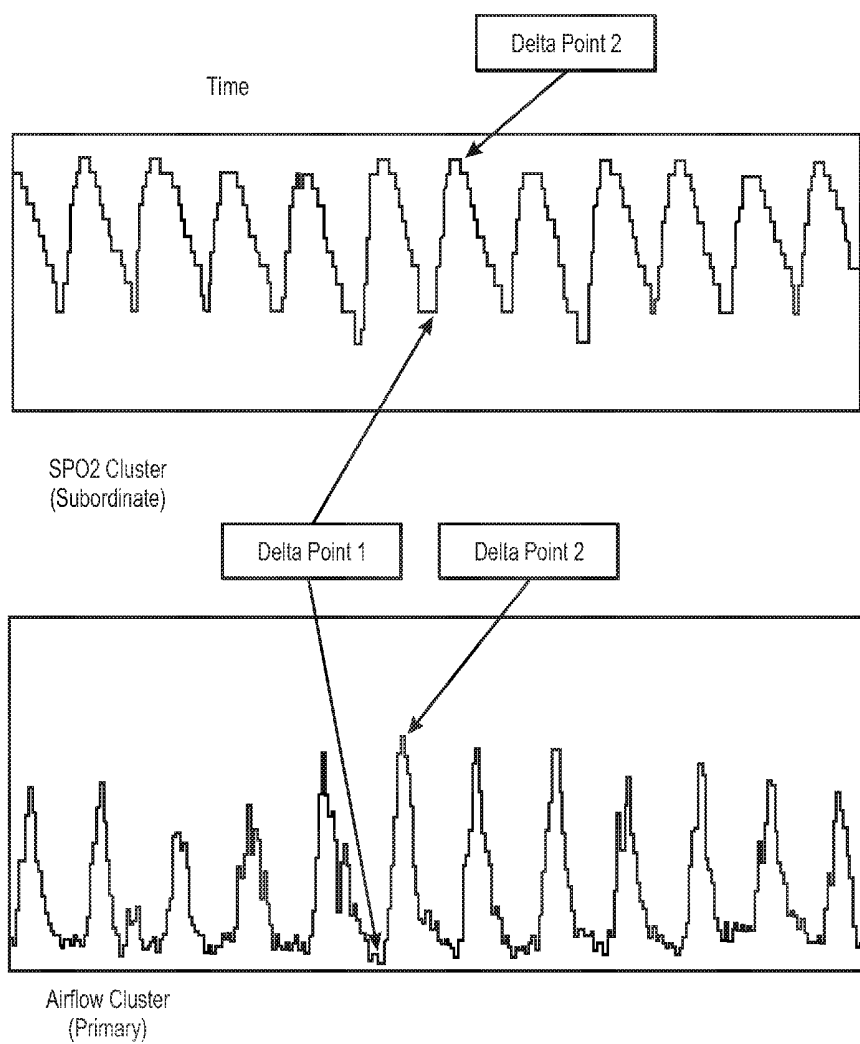

FIG. 3C

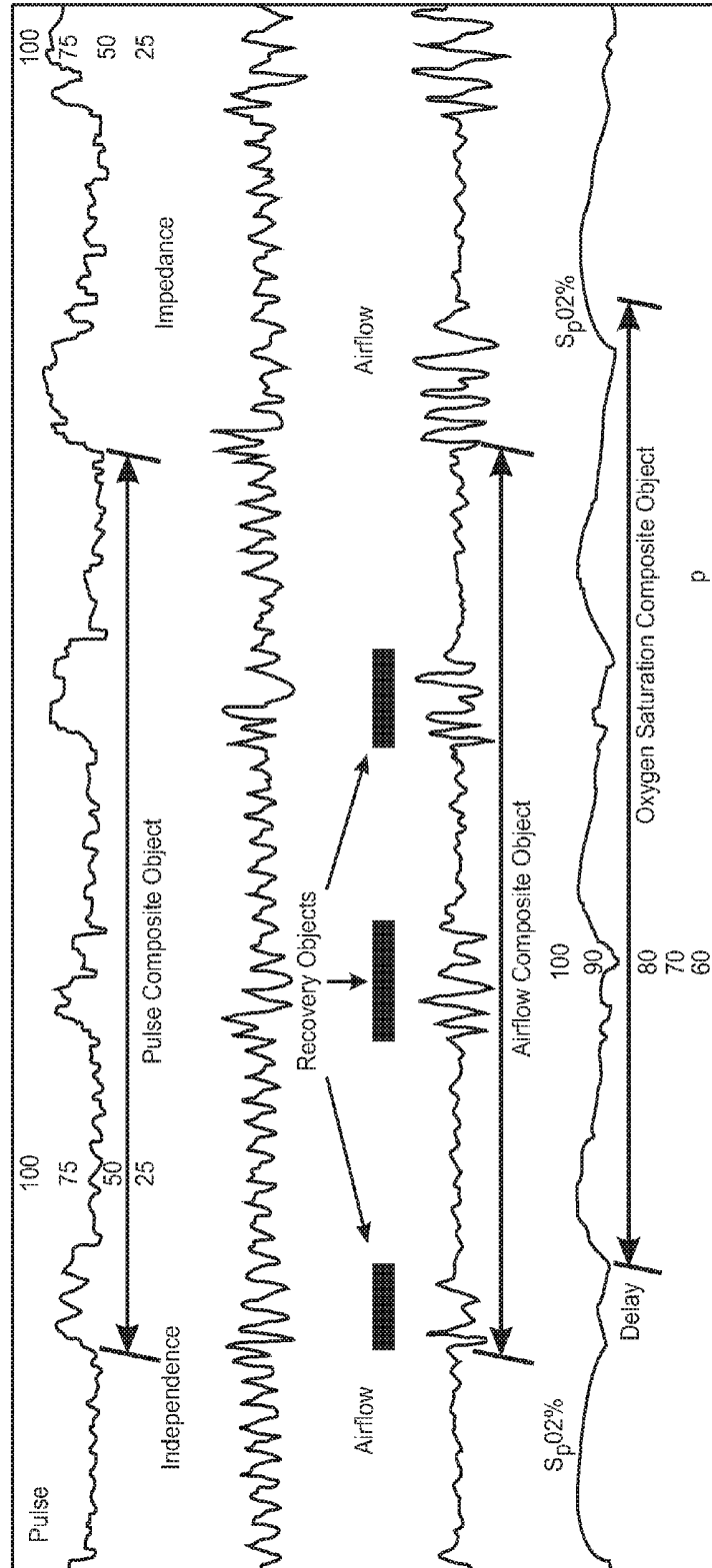

FIG. 3D

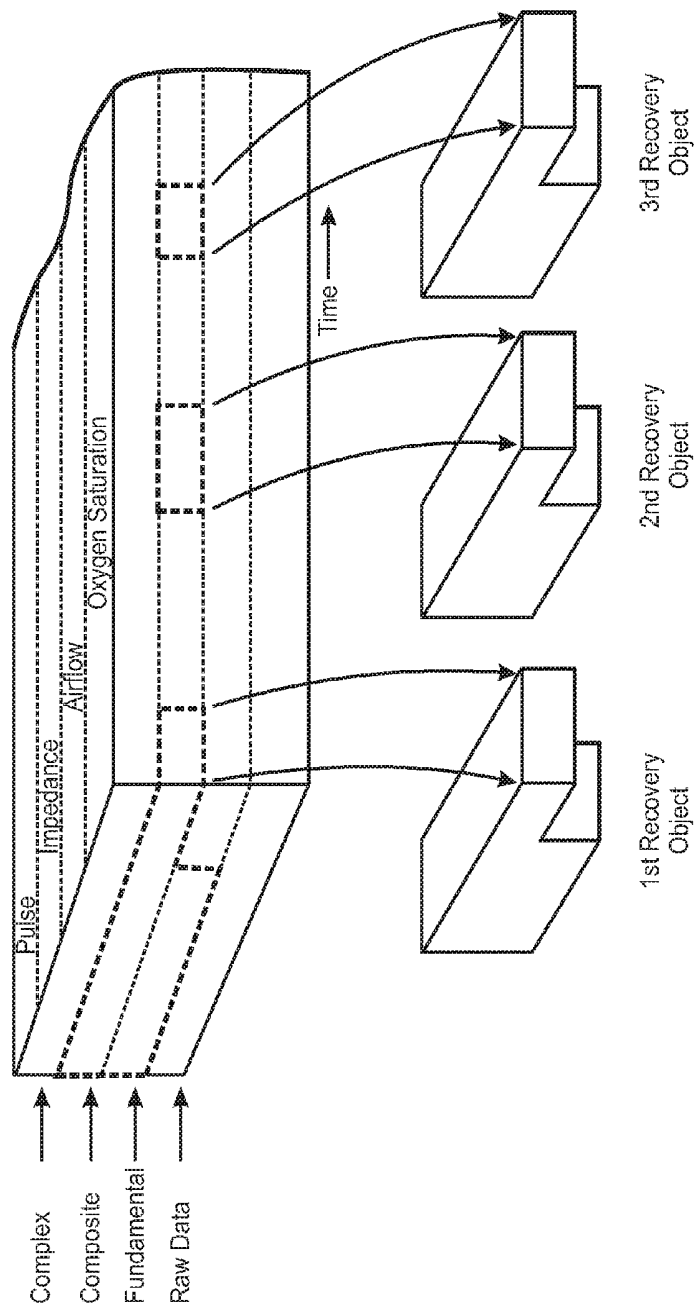

FIG. 3E

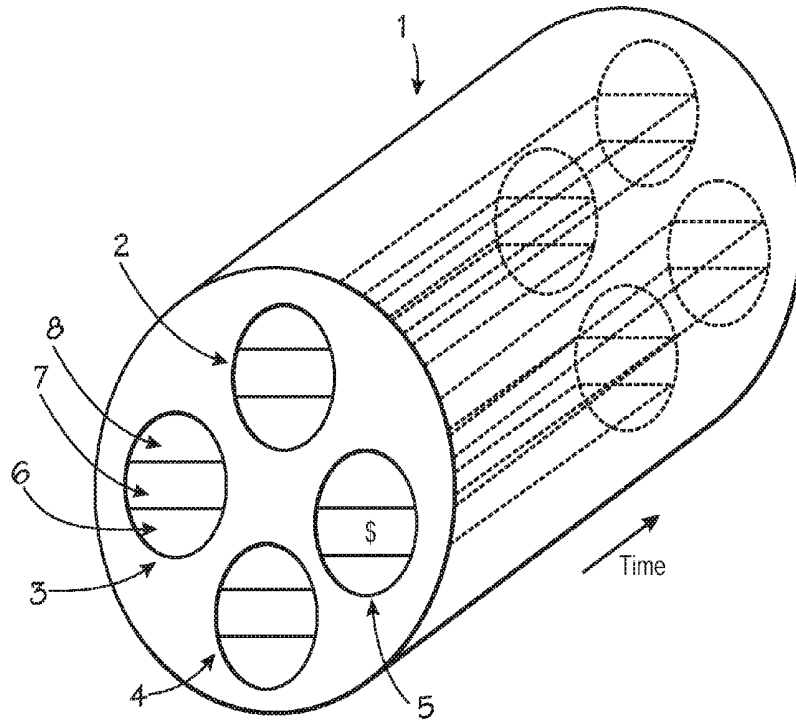
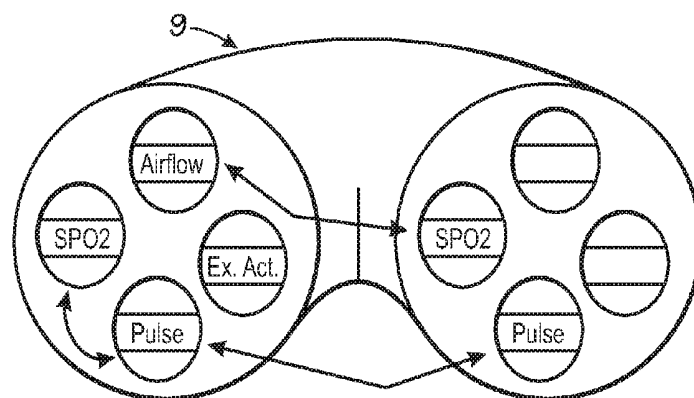

FIG. 4



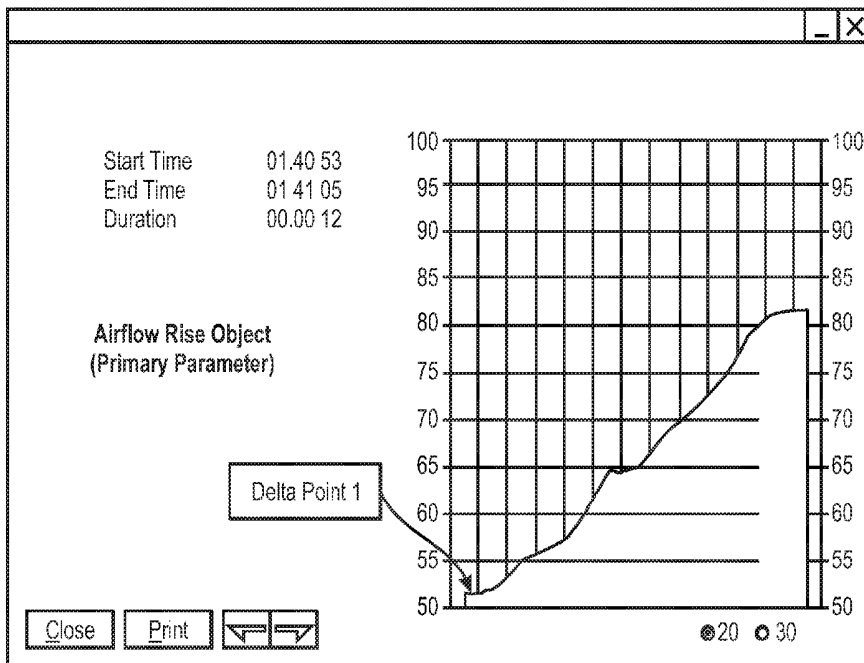
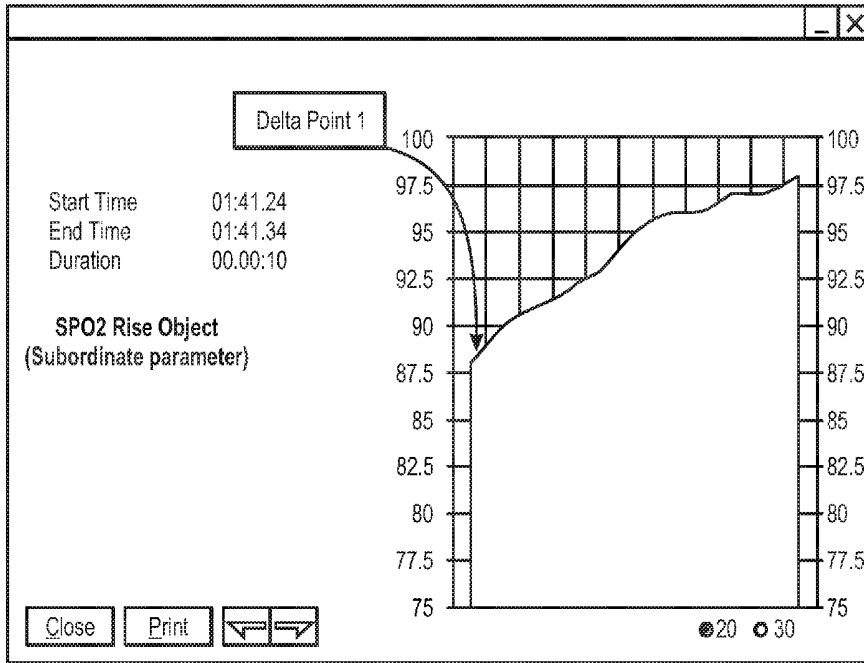

FIG. 5

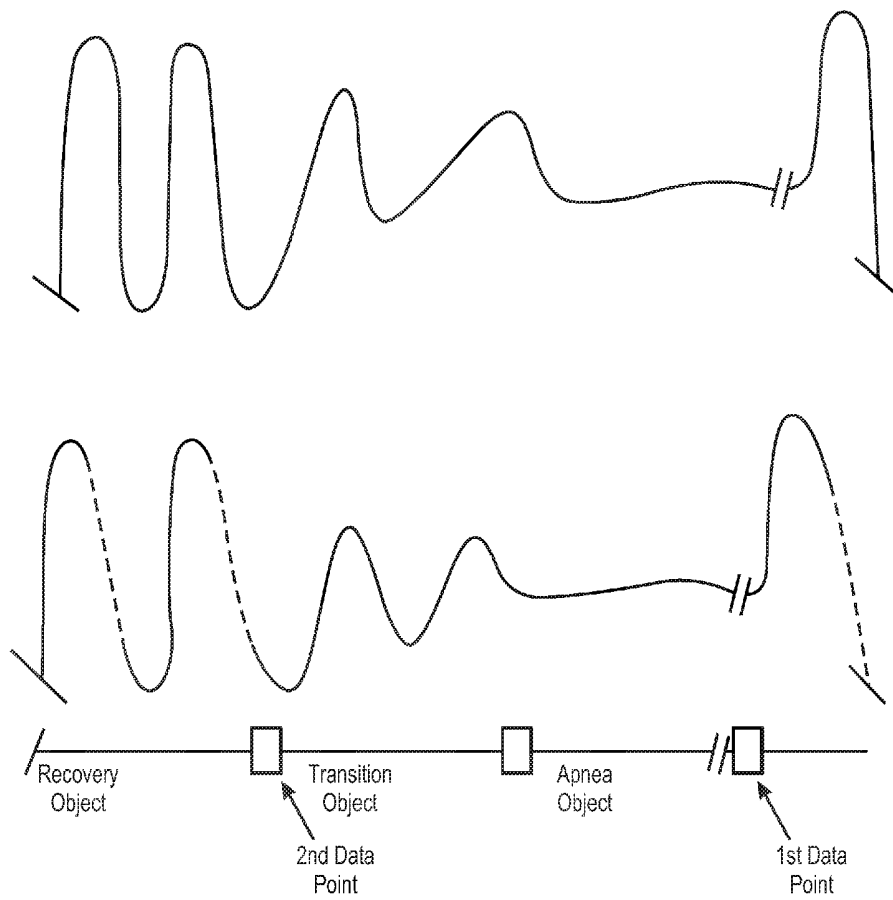

FIG. 6

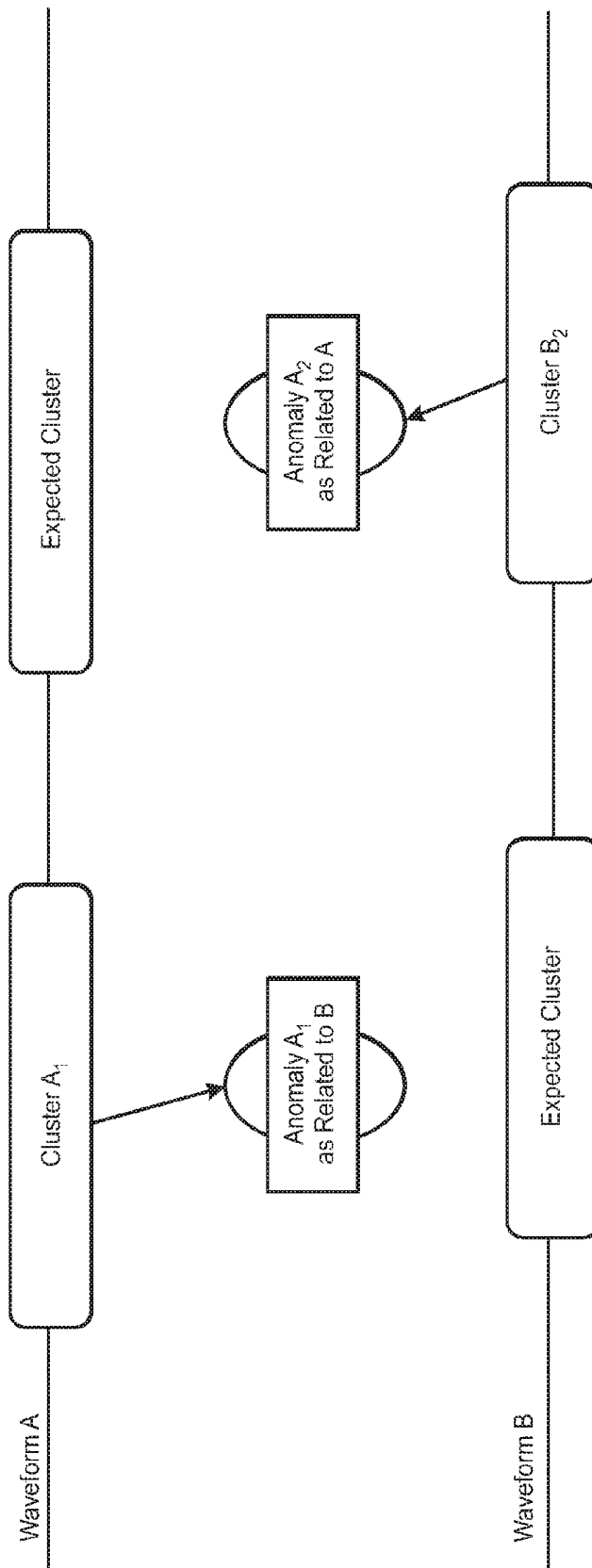

FIG. 7

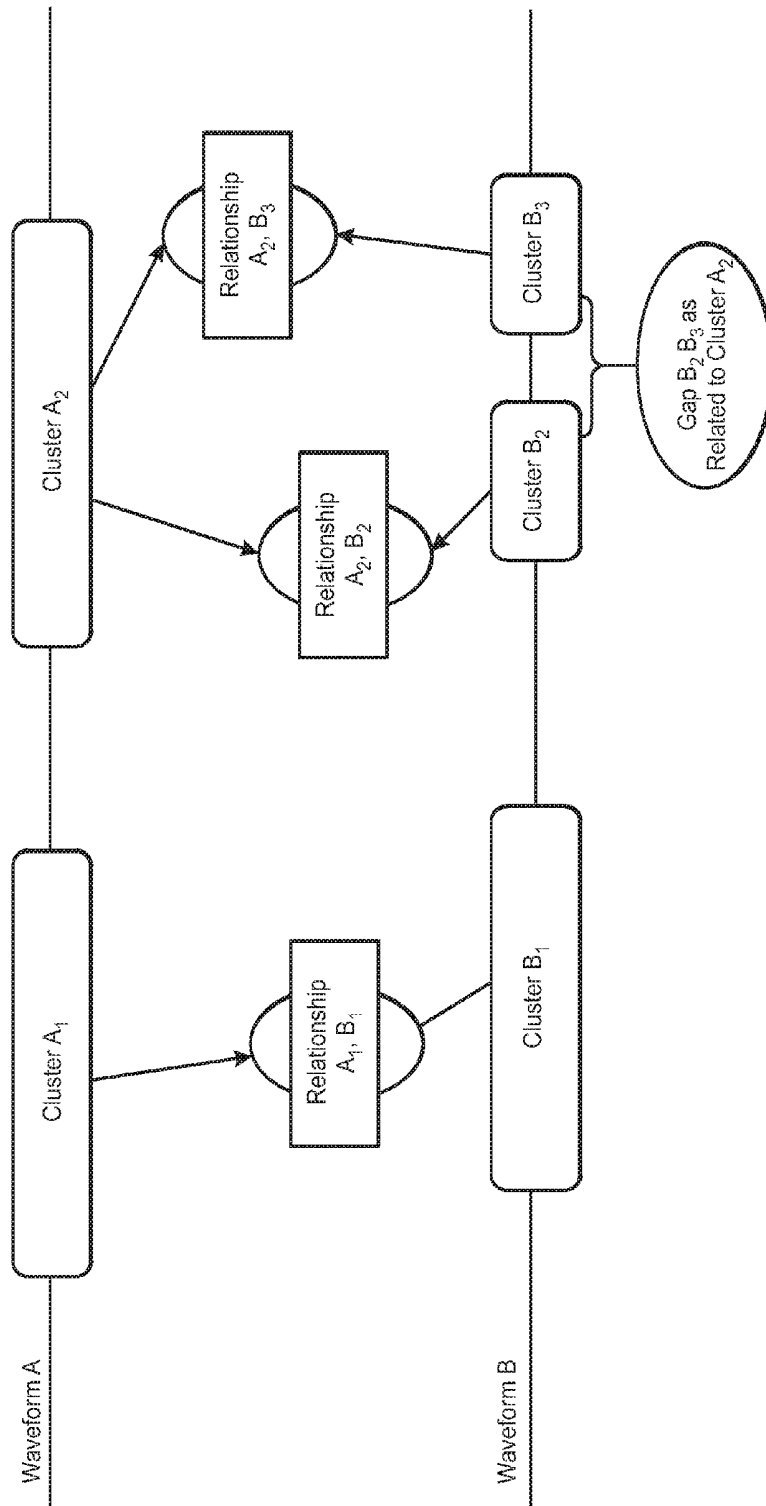

FIG. 8

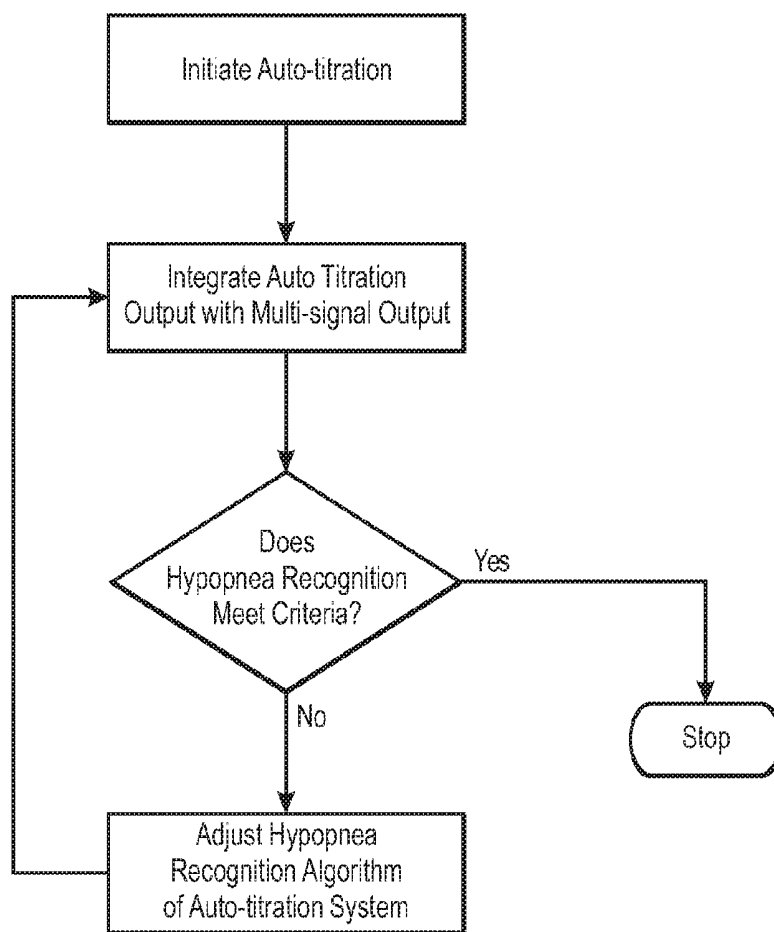

FIG. 9

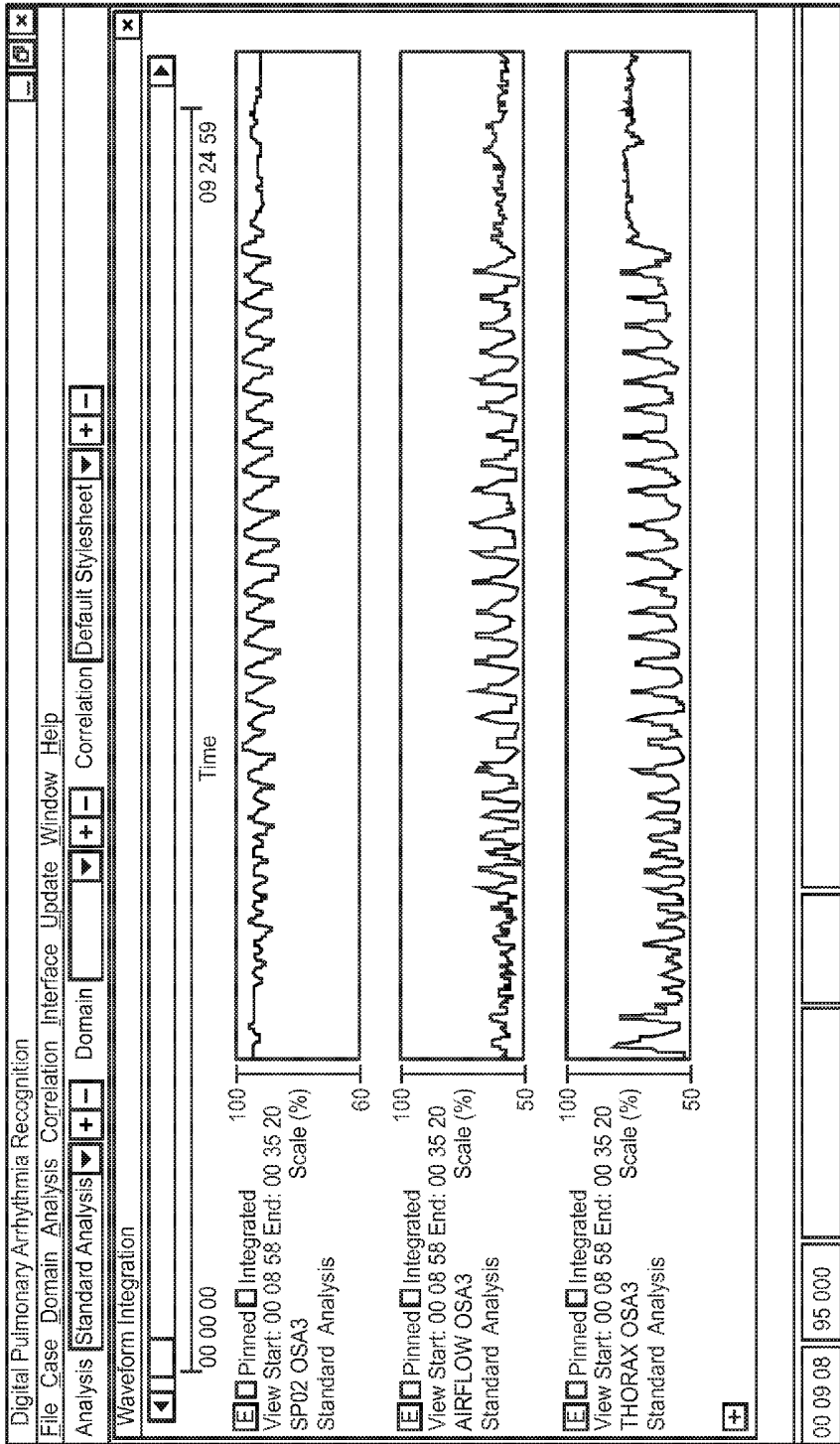

FIG. 10A

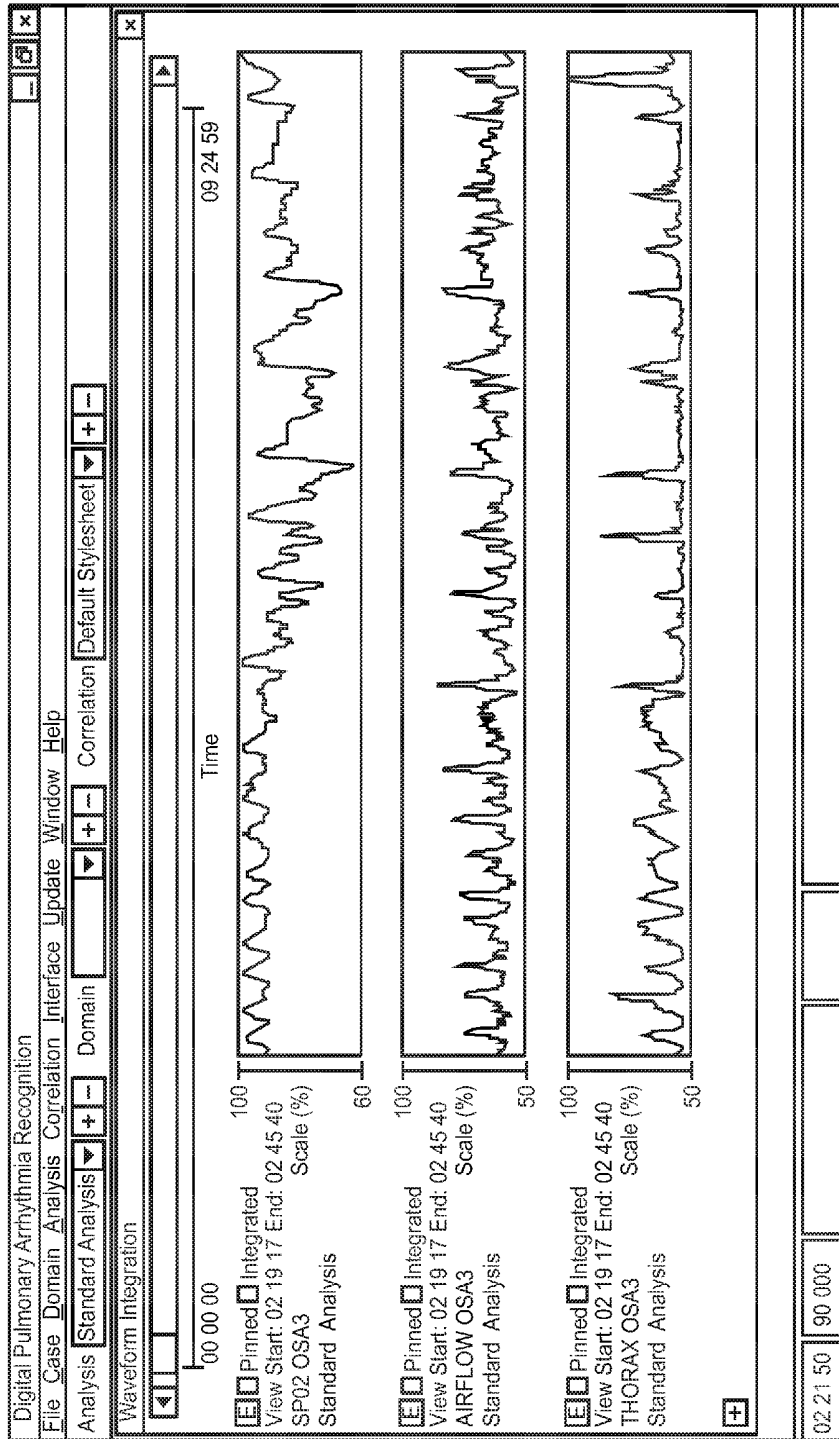

FIG. 10B

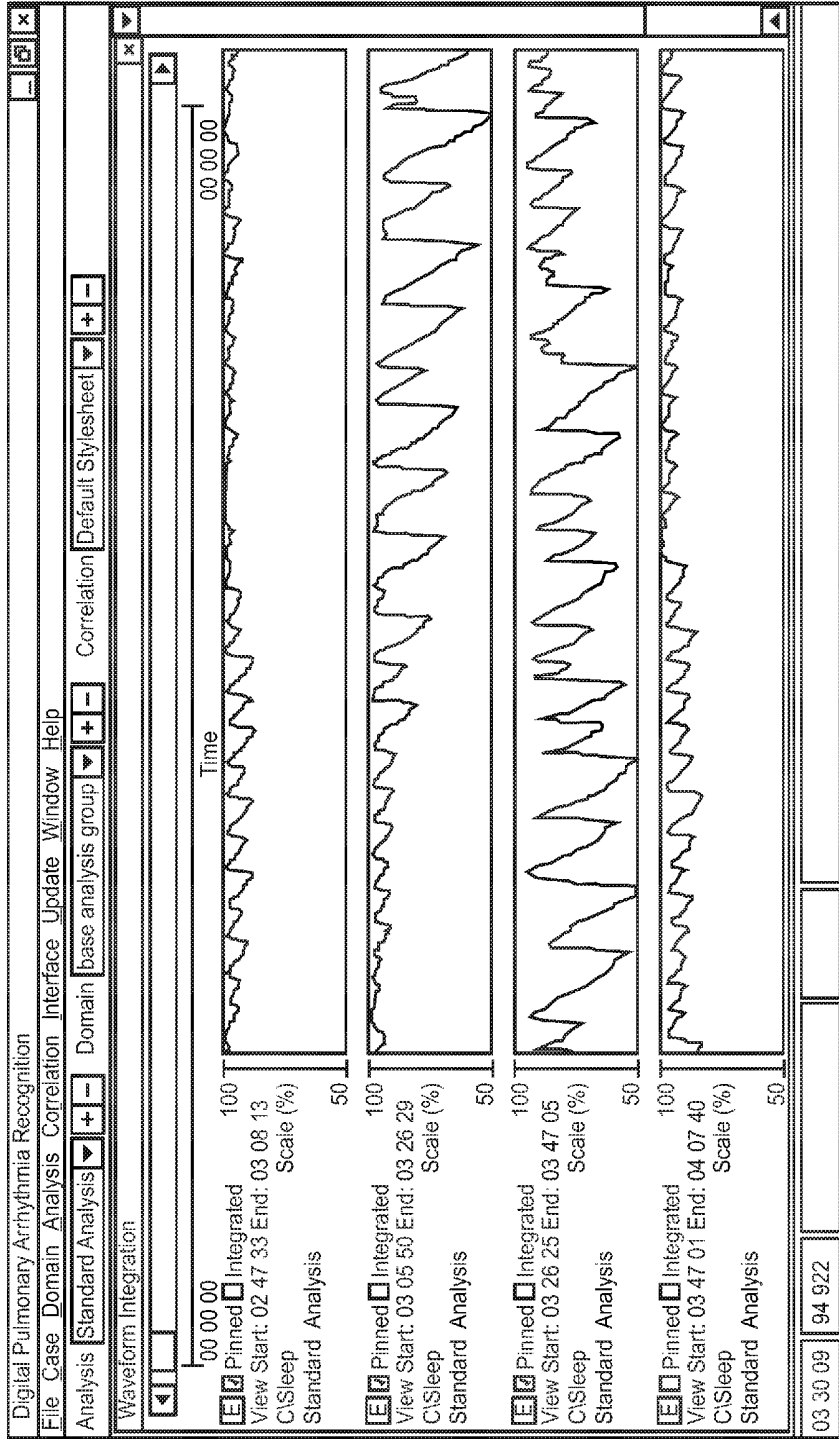

FIG. 10C

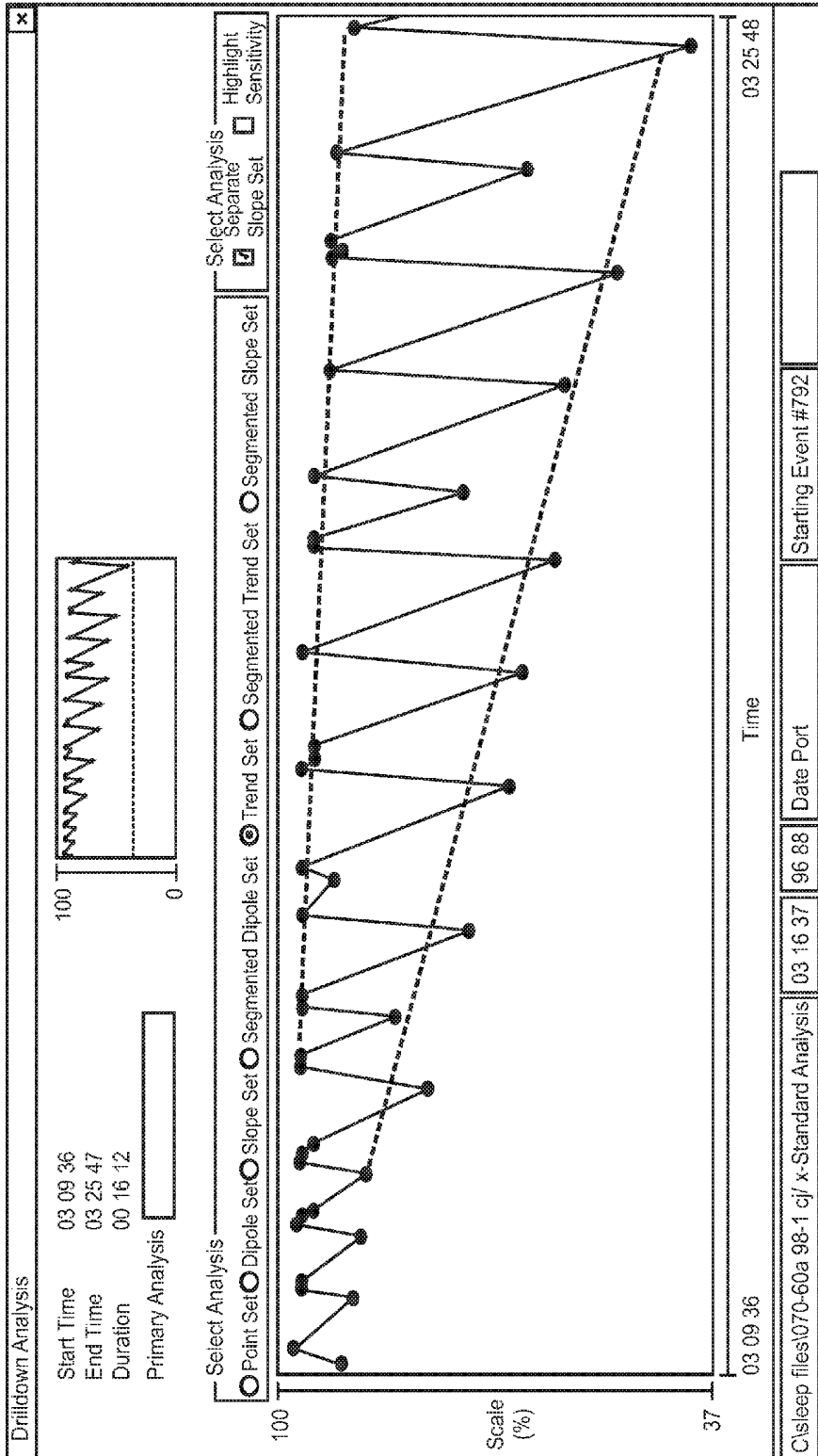

FIG. 10D

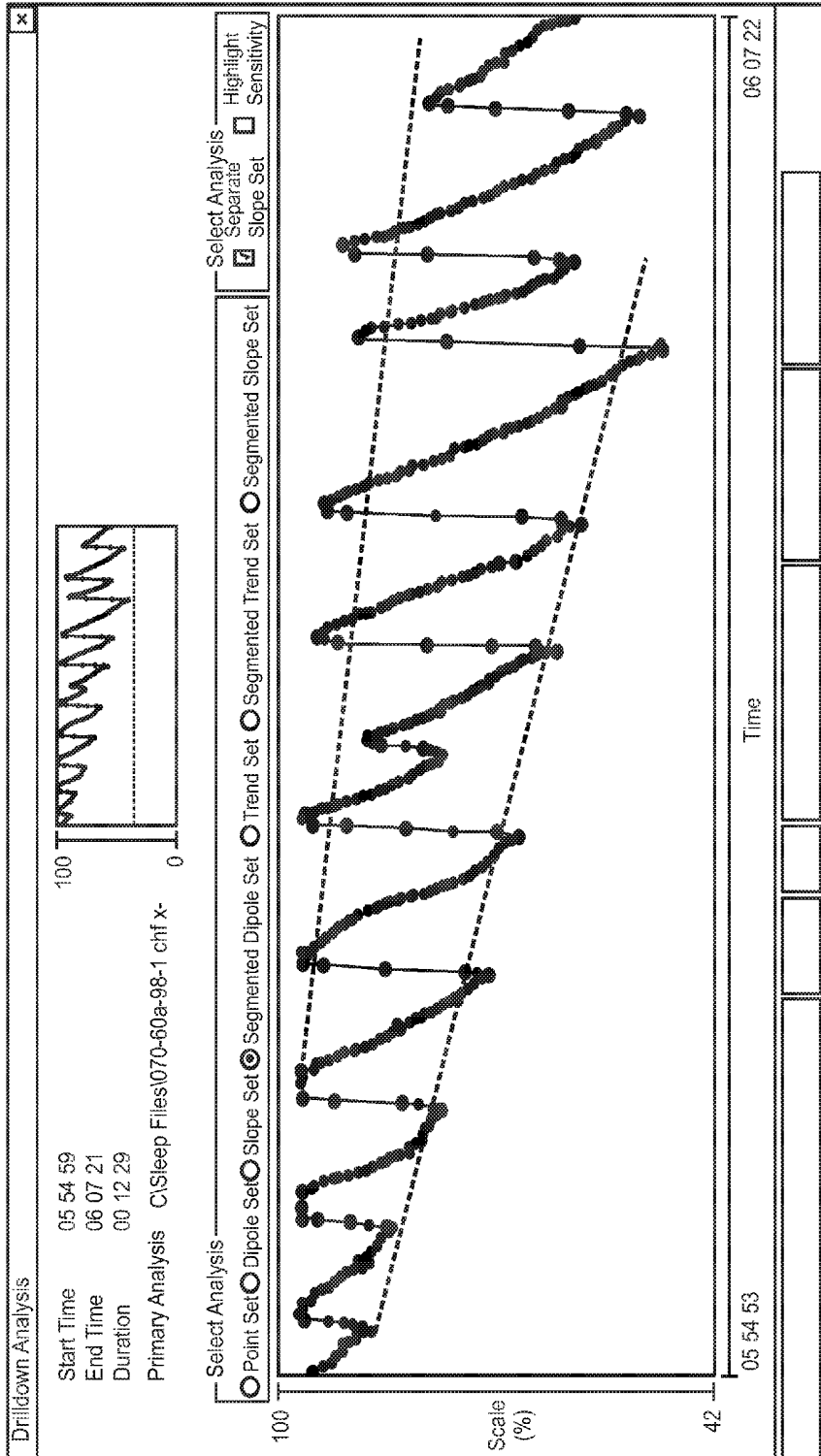

FIG. 10E

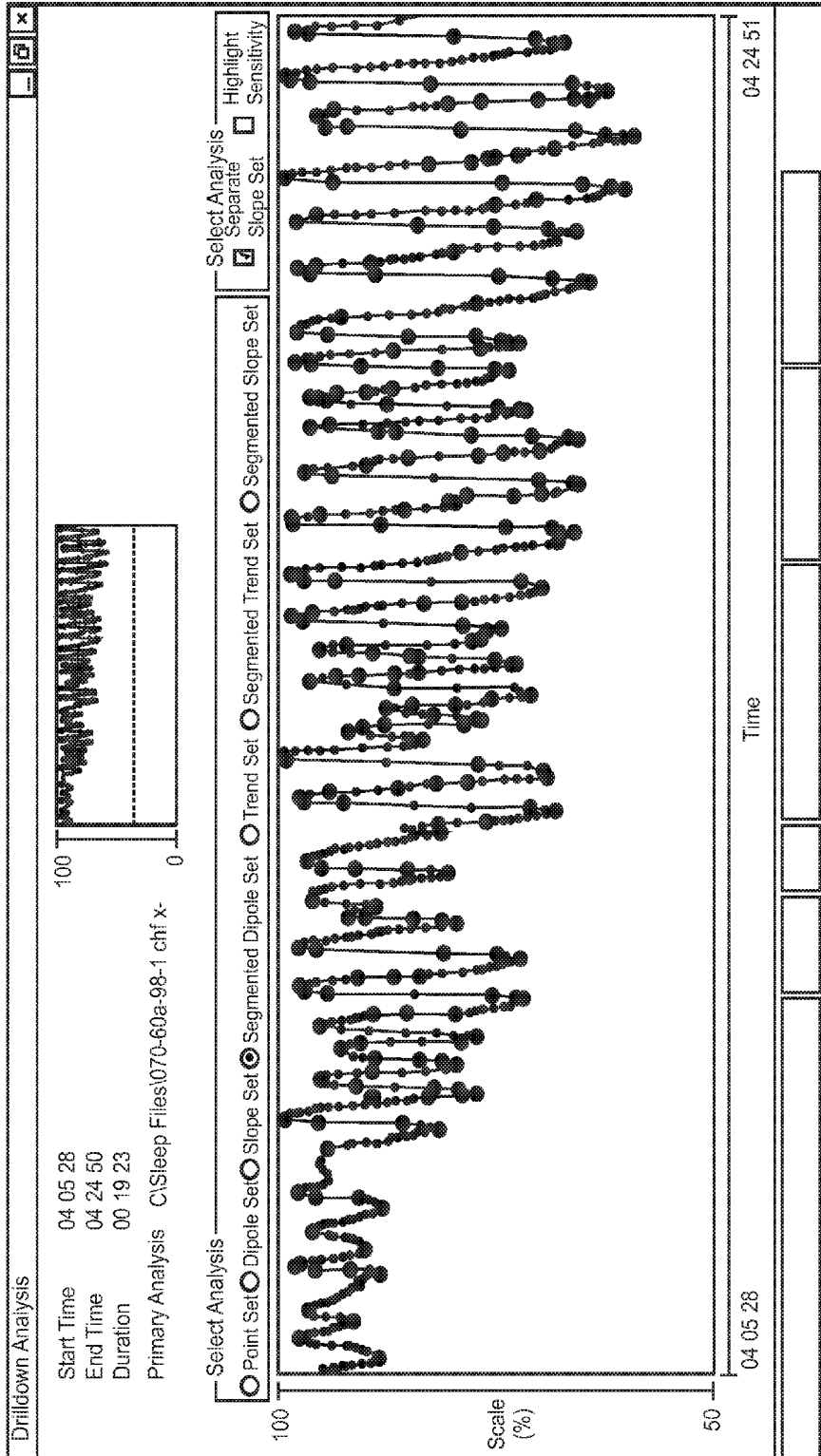

FIG. 10F

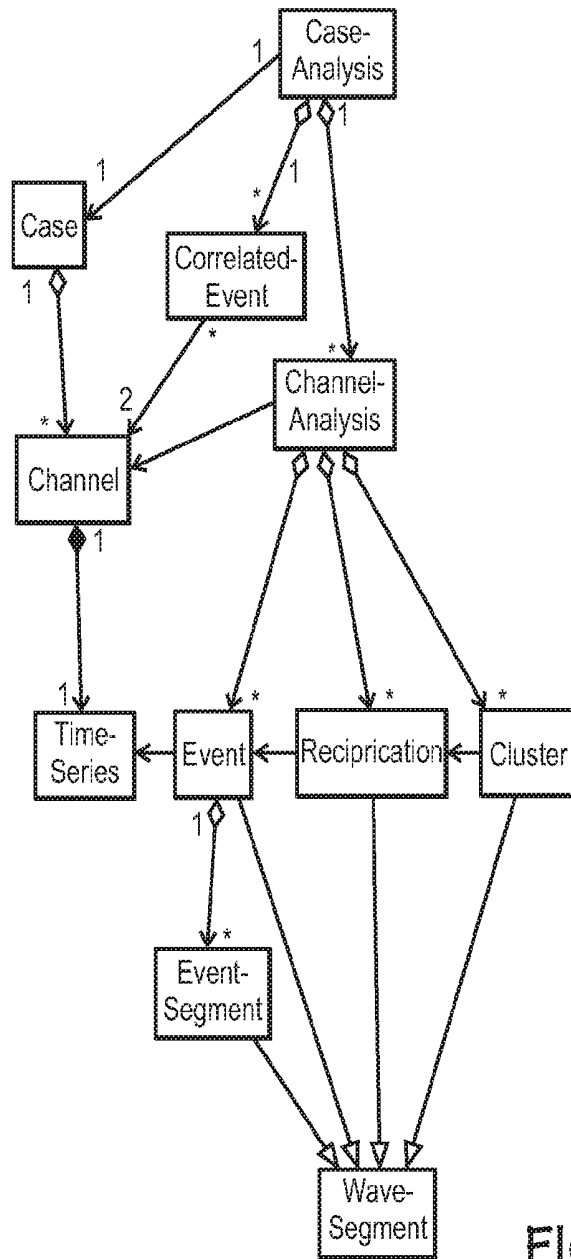

FIG. 12

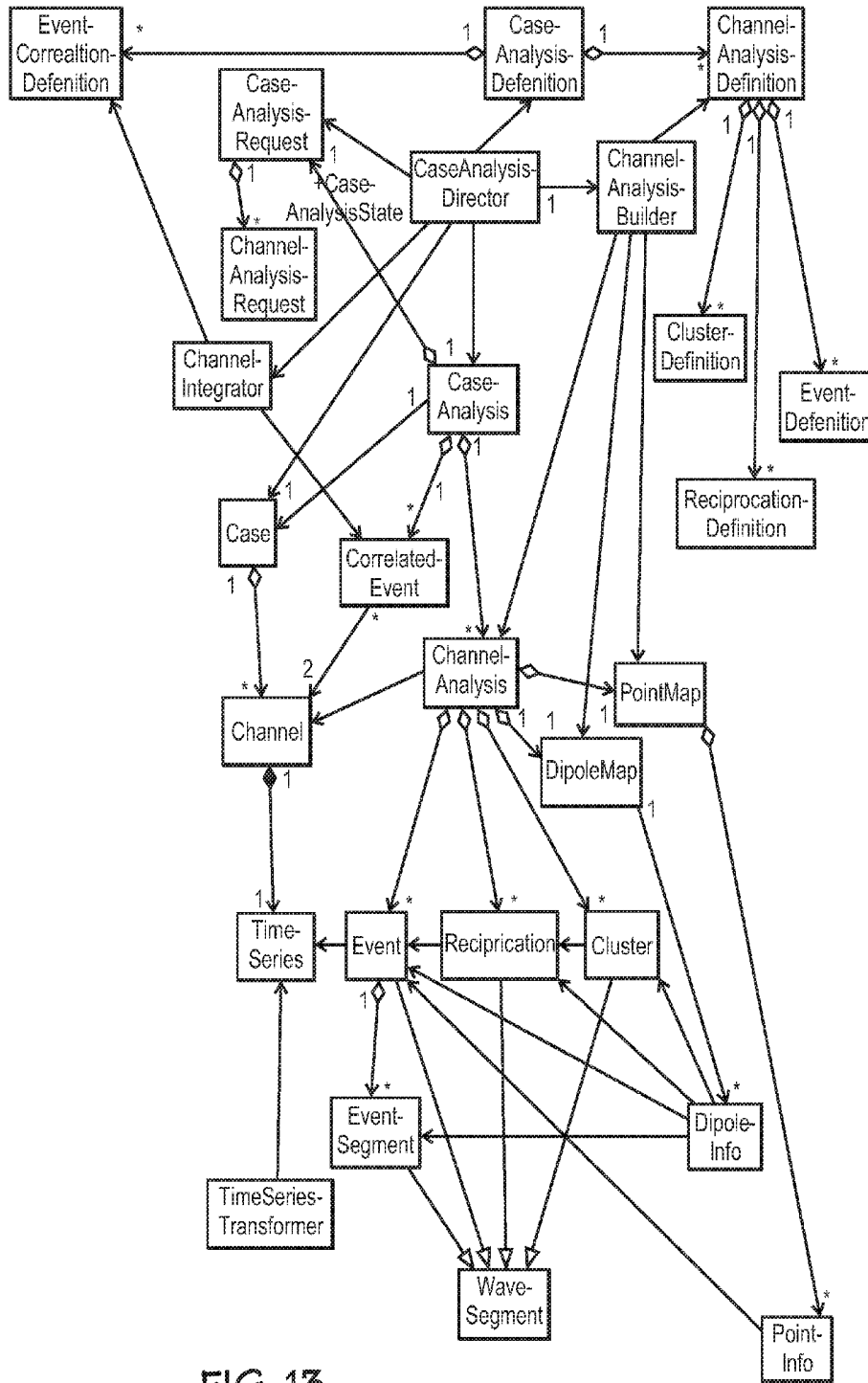

FIG. 13

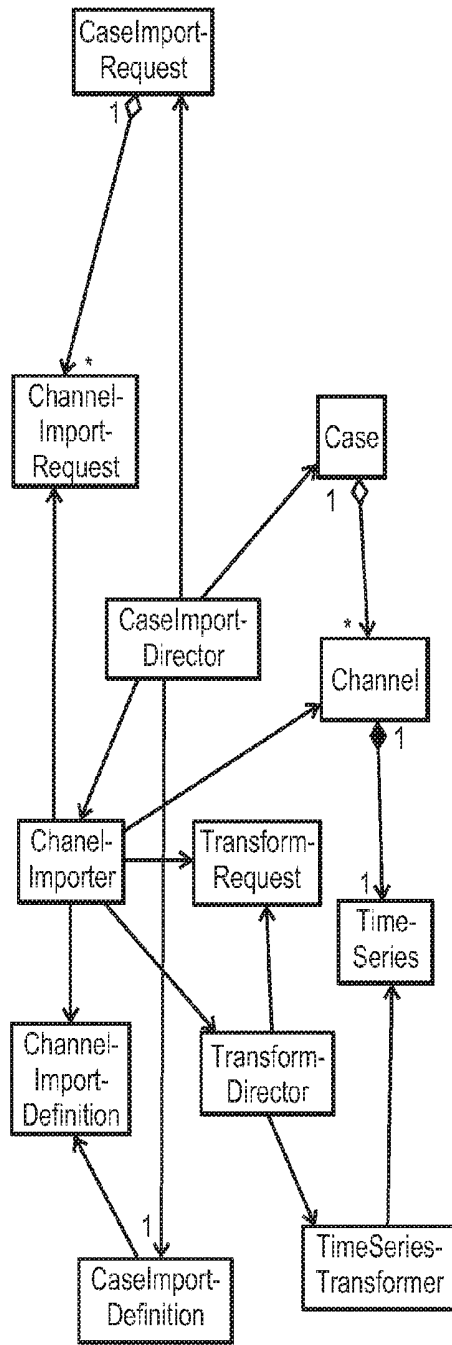

FIG. 14

channel type (sample rate, lower bound, upper bound)

[Transform1 (parameter1) [...]]

[...]

Capital letters represent channel types as follows:

Channel Type	Representation Symbol
Airflow	'A'
Pulse	'P'
Oximetry	'O'

Lower case letters represent transforms as follows:

Transform	Definition	Representative Symbol
Reformat	Change a channel from one sample rate to sample rate	'r'
Vertical Scale	Alter the vertical range of values	'v'
Smooth	Alter individual points according to surrounding points	's'
Filter	Method to remove outliers	'f'
Magnitude	Convert to the absolute value of the distance from a reference value	'm'
Derivative	Convert to the value of the slope of the dipole following the point	'd'
Custom	General purpose transformation allowing a point-by-point conversion using the formula: $aY^b + c$ where 'a', 'b' and 'c' are supplied and Y represents the value of the point before transform	'c'
Integrate	Derive a channel from two or more source channels	'i'

Transform parameters are wrapped in parenthesis as follow:

Transform	Parameter	Value Range
Reformat	Method	'a' = Average 'l' = Lowest 'w' = Weighted Average
	Points/Second	Positive Number
	Method	't' = Truncate 'c' = Convert
Vertical Scale	Upper Bound	Number
	Upper Bound	Number
Smooth	Method	'a' = Average 'l' = Lowest 'w' = Weighted Average
	Number of Points	Positive Odd Integer
Filter	Method	'l' = lowest path 'h' = highest path 'a' = alternative
	Reference Value	Number
	(No Parameters)	N/A
Custom	Multiplier	Number
	Exponent	Number
	Additive	Number
Integrate	Method	
	Channel With Which to Integrate	Defined with valid channel nomenclature

FIG. 17

Nomenclature	Definition
O(12.5,0,100)	Raw oximetry channel with a sample rate of 12.5 points per second with a lower bound of 0 and an upper bound of 100
O(12.5,0,120)v(t,0,100)r(a,1)	Oximetry channel with a sample rate of 12.5 points per second with a lower bound of 0 and upper bound of 100 reformatted to 1Hz using the average of all points sampled in a second and then smoothed with a 5 second average (5 points at 1Hz)
O(12.5,0,100)r(a,1)s(a,5)	Oximetry channel with a sample rate of 12.5 points per second with a lower bound of 0 and upper bound of 100 reformatted to 1 Hz using the average of all points sampled in a second and then smoothed with a 5 second average (5 points at 1 Hz)
A(25,-50,50)s(a,5)m(0)	Airflow sampled at 25 Hz with a range between -50 and 50 smoothed with a 0.12 second average (3 points at 25Hz) and transformed to a magnitude plot around the 0 value
O(12.5,0,100)r(a,1)s(a,5)i(x, A(25,-50,50)s(a,5)m(0))	The integration of the two previous examples using the 'x' integration method

FIG. 18

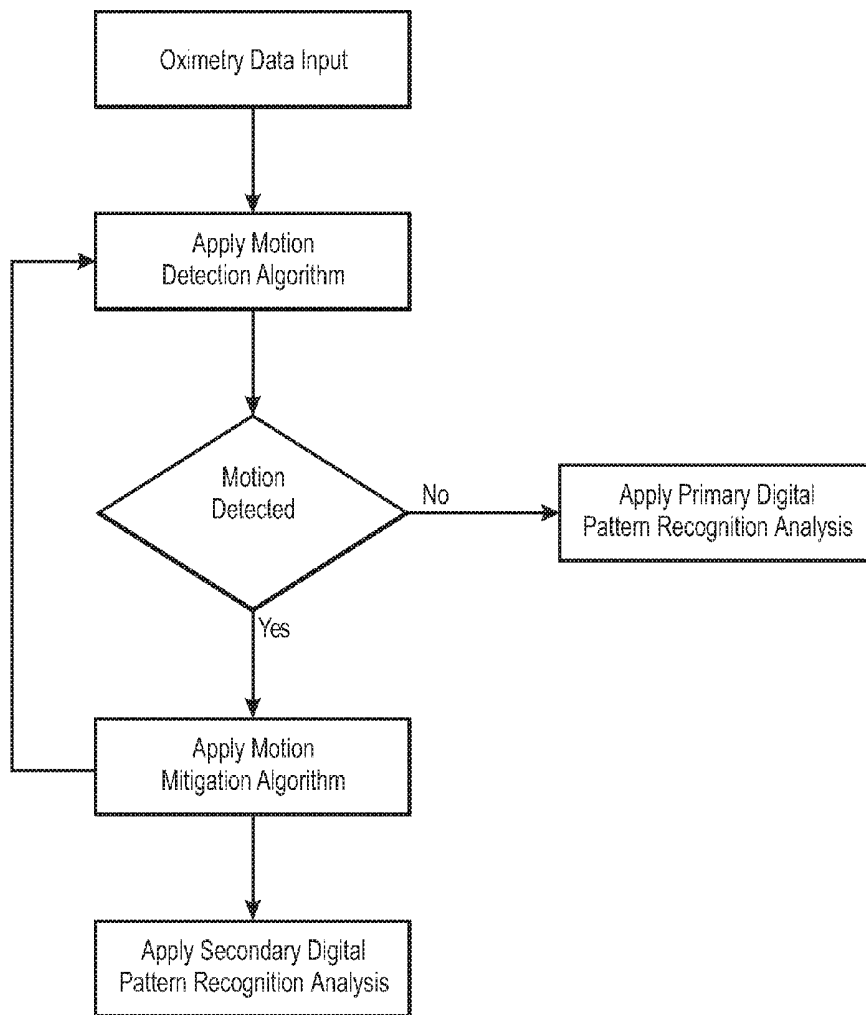

FIG. 19

Basic instability cluster detection algorithm

Let a_1, a_2, \dots, a_n be the original data points. The data can be converted to a smoother data set, x_1, x_2, \dots, x_n , by using a moving n average of the data points as a 1-4 second average for cluster recognition or as a 15-30 second average for the identification of a pathophysiologic divergence. For the sake of clarity of presentation, assume that x_i is the average of the original data points for the i^{th} second. A dipole is defined to be a pair of consecutive data points. Let $d_i = (x_i, x_{i+1})$ be the i^{th} dipole, for $i = 1, 2, \dots, n-1$. The polarity, say p_i , of the i^{th} dipole is the sign of $x_{i+1} - x_i$ (i.e. $p_i = 1$ if $x_{i+1} > x_i$, $p_i = 0$ if $x_{i+1} = x_i$ and $p_i = -1$ if $x_{i+1} < x_i$). For the purpose of automatic recognition of user specified, more complex nonlinear waveforms, the data can be converted to a set of dipole slopes, z_1, z_2, \dots, z_{n-1} . Let $z_i = (x_{i+1} - x_i)$ be the i^{th} dipole slope, for $i = 1, 2, \dots, n-1$.

To recognize a decline event by applying the iterative slope dipole method according to the present invention. Let, $\{z_1, z_2, \dots, z_n\}$ be a set of consecutive dipole slopes.

Then $\{z_1, z_2, \dots, z_n\}$ is a decline if it satisfies the following conditions:

1. z_1, z_2, \dots, z_n are less than zero i.e., the parameter level of the patient is continually falling over the set of dipole slopes. (This condition will be partially relaxed to adjust for outliers, as by the method described below for the linear method).
2. the relationship of z_1 to z_2 , z_2 to z_3, \dots, z_{n-1} to z_n , is/are specified parameter(s) defining the shape of the decline object, these specified parameters can be derived from the processor based calculations of the dipole slopes made from a user selected consecutive data set or from a set drawn by the user onto a scaled grid.

To recognize a rise event a similar method is applied wherein z_1, z_2, \dots, z_n are greater than zero. Complex events, which include rise and fall components are built from these more composite objects. Alternatively, a specific magnitude of change along a dipole slope data set can be used to specify a complex object comprised of two composite objects separating at the point of change (a waveform deflection point).

To recognize a decline event by applying the linear method according to the present invention. Let $\{x_1, x_2, \dots, x_n\}$ be a set of consecutive points and let $s = (x_n - x_1) / (n-1)$ be the overall slope of these points. (The slope could be defined by using linear regression, but this presently preferred definition allows for improved fidelity of the output by allowing rejection based on outlier identification, which will be discussed). Then $\{x_1, x_2, \dots, x_n\}$ is a decline if it satisfies the following conditions:

3. $x_1 > x_2 > \dots > x_n$, i.e., the parameter level of the patient is continually falling over the set of points. (This condition will be partially relaxed to adjust for outliers, as described below.)
4. $r - i \geq D_{min}$ where D_{min} is a specified parameter that controls the minimum duration of a decline.
5. $S_{min} \leq S \leq S_{max}$ where S_{min} and S_{max} are parameters that specify the minimum and maximum slope of a decline, respectively.

The set, $\{97, 95, 94, 96, 92, 91, 90, 88\}$, does not satisfy the current definition of a decline even though the overall level of the parameter is clearly falling during this interval. The fourth data point, 96, is an outlier to the overall pattern. In order to recognize this interval as a decline, the first condition must be relaxed to ignore outliers. The modified condition 1 is:

- 1*. Condition 1 with Outlier Detection
 - a. $x_i > x_{i+1}$.
 - b. $x_j > x_{j+1}$ or $x_{j+1} > x_{j+2}$ for $j = i+1, \dots, i-2$.
 - c. $x_{i+1} > x_i$.

To recognize a rise event, let $\{x_1, x_2, \dots, x_n\}$ be a set of consecutive points and let $s = (x_n - x_1) / (n-1)$ be the overall slope of these points. Then $\{x_1, x_2, \dots, x_n\}$ is a rise if it satisfies the following conditions:

1. $x_1 < x_2 < \dots < x_n$, i.e. the parameter level of the patient is continually rising over the set of points. (This condition will be partially relaxed to adjust for outliers, as described below.)
2. $r - i \geq D_{min}$ where D_{min} is a specified parameter that controls the minimum duration of rise.
3. $S_{min} \leq S \leq S_{max}$ where S_{min} and S_{max} are parameters that specify the minimum and maximum slope of a decline, respectively.

Similar to declines, the first condition of the definition of a rise is relaxed in order to ignore outliers. The modified condition 1 is:

- 1*. Condition 1 with Outlier Detection
 - a. $x_i < x_{i+1}$.
 - b. $x_j < x_{j+1}$ or $x_{j+1} < x_{j+2}$ for $j = i+1, \dots, i-2$.
 - c. $x_{i+1} < x_i$.

FIG. 20A

To recognize a negative reciprocation the program iterates through the data and recognize events and then identifies event relationships to define the reciprocations. The system uses polarities (as defined by the direction of parameter movement in a positive or negative direction) to test for condition (1*) rather than testing for greater than or less than. This simplifies the computer code by permitting the recognition of all decline and rise events to be combined in a single routine and ensure that decline events and rise events do not overlap, except that they may share an endpoint. The tables below show how condition (1*) can be implemented using polarities.

Equivalent Condition 1* for Decline event		
	Condition 1*	Equivalent Condition
a.	$x_i > x_{i+1}$	$p_i = -1$
b.	$x_i > x_{i+1}$ or $x_{i+1} > x_{i+2}$	$p_i = -1$ or $p_{i+1} = -1$
c.	$x_{i+1} > x_i$	$p_{i+1} = -1$

Equivalent Condition 1* for Rise event		
	Condition 1*	Equivalent Condition
a.	$x_i < x_{i+1}$	$p_i = 1$
b.	$x_i < x_{i+1}$ or $x_{i+1} < x_{i+2}$	$p_i = 1$ or $p_{i+1} = 1$
c.	$x_{i+1} < x_i$	$p_{i+1} = 1$

The pseudocode for the combined microprocessor method, which recognizes both unipolar decline events and unipolar rise events, is shown below. In this code, E is the set of events found by the method, where each event is either a decline or a rise.

```

Event Recognition
i = 1
event_polarity = pi
for j = 2 to n-2
    if (pi ≠ event_polarity) and (pi+1 ≠ event_polarity)
        r = j
        X = {xi, ..., xj}
        if event_polarity = 1
            Add X to E if it satisfies rise conditions (2) and (3)
        elseif event_polarity = -1
            Add X to E if it satisfies decline conditions (2) and (3)
        endif
        i = j
        event_polarity = pi
    endif
endfor
Add X = {xi, ..., xj} to E if it satisfies either the rise or decline conditions
    
```

Next, A specific pattern is recognized by identifying a certain sequence of consecutive events, as defined above, which comply with specific spatial relationships. For Example, a negative reciprocation is recognized when a decline event, say $D = \{x_i, \dots, x_j\}$, together with a rise event, say $R = \{x_k, \dots, x_n\}$, that closely follows it. In particular D and R must satisfy $k-i \leq t_g$, where t_g is a parameter, specified by the user, that controls the maximum amount of time between D and R to Qualify as a negative reciprocation.

The exemplary pseudocode for the microprocessor system to recognize a negative reciprocation is shown below. Let $E = \{E_1, E_2, \dots, E_j\}$ be the set of events (decline events and rise events) found by the event recognition method, and let Dr be the set of a negative reciprocation.

```

Negative Reciprocation
for h = 1 to q-1
    Let D = {xi, ..., xj} be the event Ei
    if D is a decline event
        Let R = {xk, ..., xn} be the event Ei+1
        if R is a rise event
            gap = K-j
            if gap ≤ tg
                Add (D,R) to the list, DR, of negative patterns
            endif
        endif
    endif
endfor
    
```

FIG. 20b

As noted, a cluster is a set of consecutive negative or positive reciprocation that appear close together. In particular, let $C = \{DR_i, DR_{i+1}, \dots, DR_k\}$ be a set of consecutive negative reciprocations, s_j be the time at which DR_j starts, and e_j be the time at which DR_j end. Then C is a cluster if it satisfies the following conditions:

1. $s_{j+1} - e_j \leq t_c$ for $j = i, \dots, k-1$, where t_c is a parameter, specified by the user, that controls the maximum amount of time between consecutive negative reciprocations in a cluster.
2. $k - i + 1 \geq c_{min}$ where c_{min} is a parameter, specified by the user, that controls the minimum number of negative reciprocations in a cluster

The pseudocode for the algorithm to recognize clusters of negative reciprocations is shown below. Let $DR = \{DR_1, DR_2, \dots, DR_r\}$ be the set of negative reciprocations found by the above pattern recognition method.

```

Cluster Recognition (of negative reciprocations)
f = 1;
for h = 2:r
    Let R = {x1, ..., xm} be the rise in DRh-1
    Let D = {x1, ..., xn} be the decline in DRh
    gap = i-m
    if gap > tc
        g = h-1
        if g - f + 1 ≥ cmin
            Add DRf, DRf+1, ..., DRg to the list of clusters
        endif
        f = h
    endif
endif
endfor
g = r
if g - f + 1 ≥ cmin
    Add DRf, DRf+1, ..., DRg to the list of clusters
endif
    
```

FIG. 20C

**CENTRALIZED HOSPITAL MONITORING
SYSTEM FOR AUTOMATICALLY
DETECTING UPPER AIRWAY INSTABILITY
AND FOR PREVENTING AND ABORTING
ADVERSE DRUG REACTIONS**

This application claims priority of prior application Ser. No. 11/369,355, filed Mar. 7, 2006; application Ser. No. 10/150,582, filed May 17, 2002; provisional applications 60/291,692 and 60/291,687, both filed May 17, 2001 and provisional application 60/295,484 filed Jun. 10, 2001, the disclosures and contents of each of which is incorporated by reference as if completely disclosed herein.

FIELD OF THE INVENTION

This invention relates to centralized hospital monitoring systems and particular to the organization, analysis, and automatic detection of patterns indicative of upper airway instability during sleep, deep sedation, and analgesia.

BACKGROUND AND SUMMARY OF THE
INVENTION

The high number of unnecessary deaths in the hospital due to errors related to pharmaceutical administration such as sedative and narcotics has been a recent focus of US government studies and much discussion in the literature and press. The present inventors recognized that these adverse events occur not only due to improper dosage of medications or the administration of drug to the wrong patient, as has been recently highlighted in the medical literature and press, but also due to failure to recognize complex patterns along monitored outputs (such as those shown in FIG. 2) indicative of complex patterns along monitored outputs (such as those shown in FIG. 2) indicative of patient instability before, during, and after the administration of such medications. These patterns can provide evidence that a given dose of medication, which may appear to be correct according to the Physician's Desk Reference or other source, may be too much for a given patient in a given physiologic state. Administration of standard acceptable dosages" to patients with potentially unstable physiology can produce an insidious and deadly occurrence of relative drug excess, which will not be prevented by simple computer matching of patient name and drug. Further, the present inventors recognized that failure to timely interrupt infusion upon the occurrence of physiologic instability represented a major cause of death. The timely recognition of a change in the pattern of the patient monitored output can be seen as the last opportunity to correct the mistake of wrong drug, wrong dose, wrong patient, relative drug excess, or a potentially fatal idiosyncratic or allergic reaction.

In hospitals, throughout the United States monitored patients are experiencing profound physiologic instability before and during medication infusion producing patterns as shown in FIG. 2 and yet still are being subjected to continuous infusion of further destabilizing and potentially deadly narcotics and sedation simply because the hospital monitors do not recognize the patterns nor are they programmed to warn the hospital worker or to lock out the infusion based on such recognition. An example of such instability and a system and method according to the present invention for identification of such patterns follows although, upon this teaching, the skilled artisan will recognize that there are many modifications within the scope of this teaching, which will allow the recognition of other patterns of instability.

A major factor in the development of respiratory failure (one of the most common causes of death in the hospital) is airway instability, which results in airway collapse during sedation, stroke, narcotic administration, or stupor. As illustrated in FIGS. 3a and 3b, such collapse occurs in dynamic cycles called airway instability clusters affecting a range of physiologic signals. Subgroups of patients in the hospital are at considerable risk from this type of instability. In addition patients with otherwise relatively stable airways may have instability induced by sedation or narcotics. The present inventors recognized that it is critical that this instability be recognized in real time in the hospital so that the dose can be adjusted or the drug withheld upon the recognition of this development. They also realized that it is critical to use the opportunity afforded by hospitalization in association with hospital monitoring to automatically evaluate for the common disorder induced by upper airway instability-obstructive sleep apnea. Conventional central patient monitors are neither configured to provide interpretive recognition the cluster patterns indicative of airway and ventilation instability nor to provide interpretative recognition of the relationship between and along airway instability clusters. In fact, such monitors often apply averaging algorithms, which attenuate the clusters. For these reasons thousands of patients each day enter and leave hospital-monitored units with unrecognized sleep apnea and ventilation and airway instability.

This failure of conventional hospital based patient monitors to timely and/or automatically detect cluster patterns indicative of airway instability can be seen as a major health care deficiency indicative of a long unsatisfied need. Because obstructive sleep apnea, a condition derived from airway instability, is so common, the consequence of the failure of conventional hospital monitors to routinely recognize upper airway instability clusters means that many of patients with this disorder will never be diagnosed in their lifetime. For these patients, the diagnostic opportunity was missed and the health implications and risk of complications associated with undiagnosed airway instability and sleep apnea will persist in this group throughout the rest of their life. A second group of patients will have a complication in the hospital due to the failure to timely recognize airway instability. Without recognition of the inherent instability, a patient may be extubated too early after surgery or given too much narcotic (the right drug, the right patient, the ordered dose but unknowingly a "relative drug excess"). Indeed until clusters indicative of airway instability are routinely recognized by hospital monitors, the true incidence of respiratory failure, arrest, and/or death related to the administration of IV . . . sedation and narcotics to patients in the hospital with airway instability will never be known but the number is probably in the tens of thousands each year and airway instability is just one example of the types of physiologic instability which are not automatically characterized by central hospital systems.

To understand the criticality of recognizing airway instability in real-time it is important to consider the significance of the combined effect that oxygen therapy and narcotics or sedation may have in the patient care environment in the hospital, for example, in the management of a post-operative obese patient after upper abdominal surgery. Such a patient may be at particular risk for increased airway instability in association with narcotic therapy in the through 3rd post-operative day due to sleep deprivation, airway edema, and sedation. Furthermore, in the second and third postoperative day monitoring the vigilance of hospital personnel may diminish due to perceived stability, and rebound rapid eye movement (REM) sleep which can increase upper airway instability may occur due to antecedent sleep deprivation.

Indeed, many of these patients have significant sleep apnea prior to admission to the hospital which is unknown to the surgeon or the anesthesiologist due to the subtlety of symptoms. Such patients, even with severe sleep apnea, are relatively safe at home because of an intact arousal response; however, in the hospital, narcotics and sedatives often remove this "safety net. The administration of post-operative narcotics can shift the arousal curve to the right and this can significantly increase the danger of airway instability and, therefore, place the patient at substantial risk. Many of these patients are placed on electrocardiographic monitoring but the alarms are generally set at high and low limits. Hypoxemia, induced by airway instability generally does not generally produce marked levels of tachycardia; therefore, airway instability is poorly identified by simple electrocardiographic monitoring without the identification of specific pattern of clusters of the pulse rate. In addition, simple oximetry evaluation is also a poor method to identify airway instability. Conventional hospital oximeters often have averaging intervals, which attenuate the dynamic desaturations. Even when the clustered desaturations occur they are often thought to represent false alarms because they are brief. When desaturations are recognized as potentially real this often results in the simple and often misguided addition of nasal oxygen. However, nasal oxygen may prolong the apneas and potentially increase functional airway instability. From a monitoring perspective, the addition of oxygen therapy can be seen to potentially hide the presence of significant airway instability by attenuation of the level of desaturation and reduction in the effectiveness of the oximeter as a monitoring tool in the diagnosis of this disorder.

Oxygen and sedatives can be seen as a deadly combination in patients with severely unstable airways since the sedatives increase the apneas and the oxygen hides them from the oximeter. For all these reasons, as will be shown, according to the present invention, it is critical to monitor patients with increased risk of airway instability for the specific monomorphic and polymorphic cluster patterns as will be discussed, during the administration of narcotics or sedatives.

Having identified, supra, the long and critical need, a discussion of the background physiology of upper airway instability will first be provided.

The central drive to breath, which is suppressed by sedatives or narcotics, basically controls two critical muscle groups. The upper airway "dilator muscles" and the diaphragm "pump muscles". The tone of both these muscle groups must be coordinated. A fall in afferent output from the brain controller to the airway dilators results in upper airway collapse. Alternatively, a fall in afferent output to the pump muscles causes hypoventilation.

Two major factors contribute to respiratory arrest in the presence of narcotic administration and sedation. The first and most traditionally considered potential effect of narcotics or sedation is the suppression by the narcotic or sedative of the brains afferent output to pump muscle such as the diaphragm and chest wall, resulting in inadequate tidal volume and associated fall in minute ventilation and a progressive rise in carbon dioxide levels. The rise in carbon dioxide levels causes further suppression of the arousal response, therefore, potentially causing respiratory arrest. This first cause of respiratory arrest associated with sedation or narcotics has been the primary focus of previous efforts to monitor patients postoperatively for the purpose of minimization of respiratory arrests. Both oximetry and tidal CO₂ monitoring have been used to attempt to identify and prevent this development. However, in the presence of oxygen administration, oximetry is a poor indicator of ventilation. In addition, patients may have a com-

bined cause of ventilation failure induced by the presence of both upper airway instability and decreased diaphragm output as will be discussed, this complicates the output patterns of CO₂ monitors making recognition of evolving respiratory failure due to hypoventilation more difficult for conventional threshold alarm based systems.

The second factor causing respiratory arrest due to narcotics or sedatives relates to depression of the brains afferent output to upper airway dilator muscles causing a reduction in upper airway tone. This reduction in airway tone results in dynamic airway instability and precipitates monomorphic cluster cycles of airway collapse and recovery associated with the arousal response as the patient engages in a recurrent and cyclic process of arousal based rescue from each airway collapse. If, despite the development of significant cluster of airway collapse, the narcotic administration or sedation is continued, this can lead to further prolongation of the apneas, progression to dangerous polymorphic desaturation, and eventual respiratory arrest. There is, therefore, a dynamic interaction between suppression of respiratory drive, which results in hypoventilation and suppression of respiratory drive, which results in upper airway instability. At any given time, a patient may have a greater degree of upper airway instability or a greater degree of hypo ventilation. The relative combination of these two events will determine the patterns of the output of the monitor.

Unfortunately, this has been one of the major limitations of carbon dioxide monitoring. The patients with significant upper airway obstruction are also the same patients who develop significant hypo ventilation. The upper airway obstruction may result in drop out of the nasal carbon dioxide signal due to both the upper airway obstruction, on one hand, or due to conversion from nasal to oral breathing during a recovery from the upper airway obstruction, on the other hand. Although breath by breath monitoring may show evidence of apnea, conversion from nasal to oral breathing can reduce the ability of the CO₂ monitor to identify even severe hypoventilation in association with upper airway obstruction, especially if the signal is averaged or sampled at a low rate. For this reason, conventional tidal CO₂ monitoring when applied with conventional monitors without out cluster pattern recognition may be least effective when applied to patients at greatest risk, that is, those patients with combined upper airway instability and hypoventilation. The present inventors recognized that this unique physiologic process of reentry of airway collapse could be exploited to provide a system and method for the recognition of the waveform patterns of airway instability. Several early embodiments are described in U.S. Pat. No. 6,223,064 (which is assigned to the present inventor, the disclosure and the entire contents of which are incorporated by reference is if completely disclosed herein). These systems and methods exploit the underlying cyclic physiologic process, which drives the perpetuation of a cluster of airway closures, to provide automatic recognition and indication of upper airway instability in real time. As discussed, the underlying cyclic process, which defines the behavior of the unstable upper airway, is associated with precipitous changes in ventilation and attendant precipitous changes in monitored parameters, which reflect and/or are induced by such ventilation changes. For example, cycling episodes of airway collapse and recovery produces sequential precipitous changes in waveform output defining analogous cluster waveforms in the time series of: oximetry derived pulse, airflow amplitude or/and tidal frequency, the oximetry S_pO₂, the chest wall impedance and/or motion. EKG pulse rate, and/or R to R interval, EEG (due to clustering of arousals), EMG due to clustering of motor response to

arousals, systolic time intervals, and other parameters which vary with the brisk clustered cycles of apnea and recovery. EEG is readily available in the hospital as BIS monitors, according to the present invention the detection of clusters of alpha or high amplitude, mixed frequency arousals in clusters is very useful to indicate the potential presence of airway instability. According to the present invention, anyone of these parameters singularly or in combination can be used in the hospital to detect either the absolute presence of airway instability or to provide evidence of probable airway instability so that hospital personnel know that additional testing should be applied.

Conventionally, in the hospital, the analysis of one or more time series datasets is widely used to characterize the behavior of physiologic systems and to identify the occurrence adverse events. One basic conventional hospital montage commonly connected to a central monitor by telemetry includes electrocardiogram (EKG), pulse oximetry, and chest wall impedance). Using this grouping of monitors, the human physiologic system produces a large array of highly interactive time series outputs, the dynamic relational configurations of which have substantial relevance when monitored over both brief and long time intervals. The present inventors recognized that multiple unique patterns of airway instability were present along the time series and that these different patterns could be identified to provide an interpretive output such a textual output and/or other alarm. In addition, the present inventors recognized that the complexity and time course variability of these patterns commonly overwhelms hospital workers so that timely intervention is often not applied, resulting in unnecessary death or patient injury. The inventors further recognized that the processed based recognition of these patterns could be used to take action in the interest of the health of the patient, such as automatically lock out narcotic or sedation medication or increase the level and/or type of ventilation support. They also recognized that combined central and satellite processing systems such as those used in the hospital based systems discussed supra, could be modified to provide such automatic recognition and to provide such output and/or take such action to improve the health care of patients such as automatically locking out a drug infusion upon the recognition of the interval development of an unstable pattern potentially indicative of an adverse drug reaction or titration of continuous positive pressure devices. The invention also provides a method of doing business to improve the sale of patient monitoring systems, CPAP, and disposable probes for use with the monitors.

According one aspect of the present invention, the recognition of sequential precipitous events or pathophysiologic patterns can be achieved by analyzing the spatial and/or temporal relationships between at least a portion of a waveform of a physiology parameter, (such as, for example, those listed supra), induced by at least a first episode of airway collapse and at least a portion of a waveform induced by at least a second episode of airway collapse. This can include the recognition of a pattern indicative of a cluster, which can compromise a high count of apneas with specified identifying features which occur within a short time interval along said waveform (such as 3 or more apneas within about 5-10 minutes) and/or can include the identification of a waveform pattern defined by closely spaced episodes of airway collapse defining waveform clusters. Further, the recognition can include the identification of a spatial and/or temporal relationship defined by waveform clusters, which are generated by closely spaced sequential apneas due to cycling upper airway collapse and recovery.

According to another aspect of the invention, the patterns of these complex interactive signals and the data sets defining path physiologic upper airway instability are characterized by organizing the time series into an ascending hierarchy of objects (which in one preferred embodiment are substantially in the time domain), ordering these objects into a relational data matrix and then recognizing the complex reciprocations across time series and across scales and by applying an expert system to that set of highly organized set of objects.

For the purpose of organizing and identifying physiologic datasets, according to the present invention a fundamental dynamic time series object is identified and characterized, which possesses a unique symmetry of scale. The inventors call this object a "physiologic reciprocation". For the purpose of pattern recognition, according to the present invention, a physiologic reciprocation is a fundamental variation time series output generated by an organ, an organ system, and/or an entire organism, which is at least partially reversed within a specified interval. According to the present invention reciprocations, as recognized by the processor, are widely scalable across substantially all fundamental output patterns of organ function and physiologic control. The present inventors recognized that an scaleable system which recognized and analyzed reciprocations along a time series, across different scales of the time series, and between different scales of different contemporaneously derived time series, could be used to readily identify specific dynamic physiologic patterns of interaction defining both different states of disease and health. Further, the present inventors recognized that, for the purpose of processor based pattern recognition, human physiologic function (and dysfunction) can be characterized by defining and recognizing a object hierarchy of physiologic reciprocations ordered into an ascending, inheritance based relational timed data matrix.

Using the above discoveries the present inventors recognized that typical standard central hospital monitors including those with wireless capabilities (such as the system described for example U.S. Pat. No. 6,364,834) and outpatient holter type monitors can be improved to provide automatic recognition of airway instability and sleep apnea and to provide an automatic visual or audible indication of the presence of such clusters and further to provide a visual or audible output and severity of this disorder thereby rendering the timely recognition and diagnosis of upper airway instability and obstructive sleep apnea as routine and automatic in the hospital as the diagnosis of other common diseases such as hypertension.

FIG. 3a illustrates the reentry process driving the propagation of airway instability reentry clusters. The physiologic basis for these clusters has been previously described in U.S. Pat. Nos. 5,891,023 and 6,223,064 and provisional application 60/291,691 (the entire contents of each of which are incorporated by reference as if completely disclosed herein). This cycle is present when the airway is unstable but the patient is capable of arousal. In this situation, in the sleeping or sedated patient, upon collapse of the airway, the patient does not simply die, she rescues herself and precipitously opens the airway to recover by hypoventilation. however, if the airway instability remains after the arousal and rescue is over, the airway collapses again, only to be rescued again thereby producing a cluster of closely spaced apneas with distinct spatial, frequency and temporal waveform relationships between and within apneas wherein the physiologic process reenters again and again to produce a clustered output. According to the present invention, an airway instability cluster is comprised of a plurality (two or more) of closely spaced apneas or hypopneas but the use of 3 or more apneas

is preferred. The present invention includes (but is not limited to) recognition of airway instability clusters in oxygen saturation, pulse, chest wall impedance, blood pressure, airflow (including but not limited to exhaled carbon dioxide and air temperature), nasal and oral pressure, systolic time intervals, electrocardiograph tracings (including pulse rate and R to R interval plots), timed plots of ST segment position, chest wall and/or abdominal movements (as by strain gauge, impedance, or other methods), electromyography (EMG), and electroencephalography (EEO). For all of these waveforms the basic underlying cluster pattern is similar and the same basic presently preferred cluster pattern recognition system and method, according to the present invention, can be applied to recognize them.

According to one aspect of the invention, a microprocessor system is provided for the recognition of specific dynamic patterns of interaction between a plurality of corresponding and related time series, the system comprises a processor programmed to; process a first time series to produce a lower-level time series of sequential time series fragments derived from the first time series, process the lower-level time series to produce a higher-level time series comprised of sequential time series fragments from the lower-level time series, process a second time series, the second time series being related to the first time series, produce a second lower-level time series of sequential time series fragments derived from the second time series, and identify a dynamic pattern of interaction between the first time series and the second time series. The system can be further programmed to process the lower-level time series of the second time series to; produce a higher-level time series derived from sequential time series fragments of the second lower-level, time series. The system can be programmed to process a third time-series, the third time series being related to at least one of the first and the second time series, to produce a third lower-level time series of sequential time series fragments derived from said third time series. The system can be programmed to process the higher-level time series to produce a complex-level time series derived from sequential time series fragments of said higher-level time series. The time series fragments of the first and second time series can be stored in a relational database, the fragments of the higher-level time series can comprise objects, the objects inheriting the characteristics of the objects of the lower-level time series from which they are derived. The first and second time series can comprise datasets of physiologic data points and the system can comprise a patient monitoring system wherein the dynamic pattern of interaction comprises convergent clusters of pathologic reciprocations.

It is the purpose of the present invention to provide a diagnostic system, which can convert conventional hospital-based central telemetry and bard wired monitoring systems and portable home systems to provide processor based recognition of airway instability through the recognition of patterns of closely spaced reciprocations and/or events induced by apneas and/or hypopneas both in real time and in overnight interpretive format and which can automatically lock-out narcotic infusion upon recognition of patterns of instability.

It is the purpose of the present invention to provide a system, which identifies, maps, and links waveform clusters of airway instability from simultaneously derived timed signals of multiple parameters including chest wall movement, pulse, airflow, exhaled carbon dioxide, systolic time intervals, oxygen saturation, EKG-ST segment level, EEG, EMG, and other parameters to enhance the real-time and overnight diagnosis of airway instability.

It is further the purpose of the present invention to provide a system to provide a graded index and/or indication of patterns of airway instability.

It is further the purpose of the present invention to provide a system, which provides characterization of different types of patterns of ventilation and/or upper airway instability.

It is further the purpose of the present invention to provide a system, which provides characterization and/or differentiation of different types of patterns such as monomorphic, polymorphic, and combined patterns of instability.

It is further the purpose of the present invention to provide a system, which provides characterization to output an indication of the type of pattern identified by the processor so that a decision relevant the probability of success of auto titration with CPAP and/or BIPAP can be made.

It is further the purpose of the present invention to provide timely, real-time indication such as a warning or alarm of the presence of airway instability clusters so that nurses can be aware of the presence of a potentially dangerous instability of the upper airway during titration of sedatives and/or narcotics.

It is further the purpose of the present invention to provide a system for the recognition of airway instability for combined cluster mapping of a timed dataset of nasal oral pressure with tidal CO₂ to identify clusters of conversion from nasal to oral breathing and to optimally recognize clusters indicative of airway instability in association with tidal CO₂ measurement indicative of hypoventilation.

It is the purpose of the present invention to provide an iterative object oriented waveform processing system, which can characterize, organize, and compare multiple signal levels across a plurality of signals by dividing each waveform level of each signal into objects for discretionary comparison within a relational database, object database or object relational database.

It is further the purpose of the present invention to provide a system, which automatically triggers lockout of medication infusion based on the recognition of an adverse pattern of instability along at least one timed dataset output.

It is another, aspect of the present invention to provide a system that automatically customizes treatment algorithms or diagnostic algorithms based on the analysis of waveforms of the monitored parameters.

It is further the purpose of the present invention to provide a system, which provides recognition and characterization of physiologic reciprocations across different time series scales.

It is further the purpose of the present invention to provide a system, which automatically triggers testing (and comparison of the output) of a secondary intermittently testing monitor upon the recognition of patterns indicative of physiologic instability.

It is further the purpose of the present invention to provide real time protection to patients against adverse drug and to provide a data matrix comprising matched time series of physiologic signals with a time series of drug infusion so that hospital personnel can readily match specific patterns of pathophysiologic perturbations to specific types of medications and ranges of medication dosage for patients hospital wide.

BRIEF DESCRIPTION OF THE DRAWINGS

FIG. 1 shows a schematic of a hospital central processing system for outputting and/or taking action based on the analysis of the time series processing according to the present invention.

FIG. 2 shows the organization of airflow waveforms into ascending object levels identifying pathophysiologic reciprocations, which demonstrate recognizable symmetry of scale according to the present invention. Note that, according to the present invention, reciprocations at the complex and composite levels inherit the reciprocations from the levels below them in ascending order.

FIG. 3a shows an illustration of the complexity of the mechanisms defining the timed interactions of physiologic systems induced by upper airway instability, which the present inventor calls an "airway instability cluster reentry cycle" showing the derivative reciprocations, which are generated by the cycling producing the corresponding cluster of reciprocations.

FIG. 3b shows a schematic object mapping at the composite level of two simultaneously measured parameters, which are perturbed to produce clusters in response to the upper airway instability cycles of FIG. 3a, which is automatically detected according to the present invention.

FIG. 3c shows an example of a monomorphic cluster pattern indicative of airway instability and derived from the mechanism of FIG. 3a, which is automatically detected according to the present invention. The figure shows a raw data set of pulse rate (by oximetry), airflow (by nasal-oral thermister).

FIG. 3d shows another example of monomorphic cluster pattern derived from the mechanism of FIG. 3a, which now includes a corresponding pulse rate cluster, which is automatically detected according to the present invention. Note the fundamental airflow positive and negative reciprocations in this figure generate larger scale positive reciprocations of airflow recovery (with the patterns shown in FIG. 3b)

FIG. 3e shows a schematic representation of a portion of a multi-signal object as derived from the multiple corresponding time series of FIG. 3c with three multi-signal recovery objects at the composite object level identified for additional processing according to the present invention. Note that objects at the composite level encapsulate the waveform objects from lower levels.

FIG. 4 shows a three-dimensional representation of the cylindrical data matrix comprised of corresponding, streaming, time series of objects from four different timed data sets, with each of the four data sets divided into an ascending hierarchy of 3 levels.

FIG. 5 shows a selected subordinate composite object of oxygen saturation of FIG. 3c, matched with its corresponding primary composite object of airflow, as they are stored as objects at the composite level in the relational database, object database or object relational database.

FIG. 6 shows a comparison between two data sets of tidal airflow reciprocations at the fundamental level wherein the second data set shows evidence of expiratory airflow delay during the recovery object, note that the recovery object is recognized at the composite level and it has inherited (and therefore encapsulates) the fundamental tidal airflow reciprocation objects.

FIG. 7 shows a schematic object mapping at the composite level of two simultaneously measured parameters with a region of anticipated composite objects according to the present invention.

FIG. 8 shows a schematic object mapping and scoring at the composite level of two simultaneously measured parameters with the region of anticipated composite objects according to the present invention.

FIG. 9 shows a schematic of a system for customizing a CPAP auto-titration algorithm based on the analysis of reciprocations of multiple corresponding signals across multiple scales.

FIG. 10a shows a typical monomorphic airway instability cluster along times series of oximetry, airflow, and thorax movement.

FIG. 10b shows a polymorphic airway instability cluster along times series of oximetry, airflow, and thorax movement.

FIG. 10c shows a times series of oximetry over a period of about 2 hours and 40 minutes demonstrating a monomorphic airway instability cluster of negative oxygen saturation reciprocations degenerating into a polymorphic cluster exhibiting marked instability of control evidenced by marked reciprocations of the peaks and nadirs of the negative oximetry reciprocations within the cluster. This represents a markedly adverse pathophysiologic pattern, which is automatically recognized and graded according to the present invention.

FIG. 10d shows a 16.2-minute segment of the times series of oximetry of FIG. 10c illustrating a modest decline component of a pathophysiologic pattern of monomorphic reciprocation.

FIG. 10e shows a 12.5-minute segment of a times series of oximetry illustrating a more severe decline of the peaks comprising degeneration into a polymorphic pattern indicative of severely adverse pathophysiologic pattern and which can be indicative of an important decline in arousal threshold and incomplete arousal response which fails to completely correct the negative reciprocation. This polymorphic pattern is automatically recognized according to the present invention to provide an output indication or to take action such as to lock out medication.

FIG. 10f shows a 19.2-minute segment of a time series of oximetry illustrating a modest variation of the peaks of reciprocations with negative reciprocations of the nadirs each said reciprocation becoming more negative. This peak variation is consistent with a mild polymorphic cluster. Note that the variations of the nadirs can be indicative of an important instability and decline in arousal threshold despite a complete or nearly complete arousal response. This pattern is automatically recognized according to the present invention to provide an output indication or to take action such as to lock out medication.

FIG. 11 shows a diagram represents both the real-world objects (e.g. reciprocations) and support objects for the rapid creation, rendering of such object to a graphical user interface and persisting such objects to relational database and/or a hierarchical data store (e.g. eXtensible Markup Language (XML) documents).

FIG. 12 shows core objects of the presently preferred analysis.

FIG. 13 shows the preferred support mechanisms for the creation of the analysis.

FIG. 14 shows one preferred data acquisition and transformation system for preceding the analysis.

FIG. 17 shows one presently preferred nomenclature for the exemplary parameters of airflow, pulse, and oxygen saturation. Illustrative examples of designation by this nomenclature are shown in FIG. 18.

FIG. 19 shows a schematic of a system for automatically changing the processing analysis of subsequent time-series portion based on the analysis output of an earlier portion of the time series.

DESCRIPTION OF THE PRESENTLY PREFERRED EMBODIMENTS

One presently preferred system for processing, analyzing and acting-on a time series of multi-signal objects is shown in

FIG. 1. The examples provided herein show the application of this system for real time detection, monitoring, and treatment of upper airway and ventilation instability although the present invention is useful for detecting a broad range of patterns and instabilities (as described in co pending. The system includes a portable bedside processor 5 preferably having at least a first sensor 20 and a second sensor 25, which preferably provide input for at least two of the signals discussed supra. The system includes a transmitter 35 to a central processing unit 37. The bedside processor 5 preferably includes an output screen 38, which provides the nurse with a bedside indication of the sensor output. The bedside processors can be connected to a controller of a treatment or stimulation device 50, which can include a drug delivery system such as a syringe pump, a positive pressure ventilation device, an automatic defibrillator, a tactile stimulator, the processor itself, to adjust the analysis of the time-series inputs. The central unit 37 preferably includes as output screen 55 and printer 60 for generating a hard copy for physician interpretation. According to present invention, as will be discussed in detail, the system thereby allows recognition of airway instability, complications related to such instability, and pathophysiologic divergence in real time from a single or multiple inputs. The bedside processor is preferably connected to a secondary processor 40 which can be a unit, which takes action such as locking out a medication infusion, performing measurements intermittently and/or on demand such as a non-invasive blood pressure monitor or an ex-vivo monitor, which draws blood into contact with a sensor on demand for testing to derive data points for addition to the multi-signal objects. The secondary processor 40 includes at least one sensor or controller 45. The output of the bedside processor can either be transmitted to the central processor 37 or to the bedside monitor 5 to render a new object output, action, or analysis.

In one example the occurrence of a dynamic clustering of apneas can be identified and the infusion pump (which can be for example a patient controlled analgesia (PCA) device can be automatically locked out to prevent further infusion and an output such as "Caution—pattern suggestive of mild upper airway instability at dose of 1 mg Morphine." If in this example the nurse increases the dose to 2 milligram and the pattern shows an increase in severity an output such as "Pattern suggestive of moderated upper airway instability at dose of 2 mg/hr. of Morphine-morphine locked out". To maintain Morphine dose at the 2 mg. level for this patient, the nurse or physician would have to override the lockout and preferably document the reason for override. Upon an override the processor then tracks the severity of the clusters and if the clusters reaches an additional severity threshold an output such as "Severe upper airway instability—Morphine locked out" is provided. According to the present invention the onset of the drug administration is recognized by the central processor and the dose administered becomes a time series, which can then be matched to the patterns of the monitored physiologic time series. In addition to real time protection, the data matrix comprising matched time series of physiologic signals with a time series of drug infusion provides an ability for hospital personnel to readily match specific patterns of pathophysiologic perturbations to specific types of medications and ranges of medication dosage for patients hospital wide.

FIG. 2 illustrates the ascending object processing levels according to the present invention, which are next applied to order the objects to recognize the patterns which are identified by the system of FIG. 1 to provide an automatic indication and/or action based a pattern indicative of an adverse physiologic occurrence. In the preferred embodiment, these

levels are defined for each signal and comparisons can be made across different levels between different signals. Physiologic reciprocations are identified (if present) and characterized at each level. In FIG. 2 the first level is comprised of the raw data set. The data from this first level are then converted by the processor into a sequence of fundamental segments called dipoles to form the second fundamental object level. In one embodiment, all of the objects, which will ultimately define complex multi-signal objects, are comprised of these sequential fundamental objects having the simple characteristics of slope, polarity, and duration. At this level, the dipoles are used to render the next level, called the "composite object level".

The composite object level is comprised of sequential and overlapping composite objects, and particularly reciprocations, which are composed, of a specific sequence of dipoles as defined by selected criteria. Each of these composite objects has similar primary characteristics of a slope, duration, and polarity to the fundamental objects. However, for the composite objects, the characteristic of slope can comprise a time series characteristic given as a slope dataset. The composite object level also has the characteristic of "intervening interval time-series" defined by a time series of the intervals between the recognized or selected composite objects. At this level a wide range of discretionary index characteristics can be derived from the comparison of basic characteristics of composite objects. Examples of such index characteristics include; a "shape characteristic" as derived from any specified portion of the slope dataset of the object, a "positional characteristic" as derived from, for example, the value of the lowest or highest points of the object, or a "dimensional value characteristic" as derived by calculating the absolute difference between specified data points such as the value of the lowest and the highest values of the object, or a "frequency characteristic" such as may be derived from performing a Fourier transform on the dataset of the object.

The next analysis level is called the "complex object level". In this level, each sequential complex object comprises plurality of composite objects meeting specific criteria. According to the present invention, the patterns of reciprocations at the complex level are representative of a balance between physiologic perturbation and the control. As such they are useful to characterize the integrity of control of the organism as well as the severity and character of the perturbation. According to the present invention, complex physiologic reciprocations are generally derived from composite level reciprocations and inherit their characteristics. Therefore a complex object (such as a recovery object) inherits the composite (tidal breath) reciprocations from which it is derived and this is exploited by the system as will be discussed. Complex objects have the same categories of primary characteristics and derived index characteristics as a composite object. A complex object also has the additional characteristics of "composite object frequency" or "composite object order" which can be used as search criteria as part of an overlaid expert system. These can be defined by a selected frequency or order of composite object types, which are specified as defining a given complex object. A complex object also has additional higher-level characteristics defined by the time-series of the shapes, dimensional values, and positional characteristics of its component composite objects. As described for the composite objects, similar index characteristics of the complex objects can be derived from these characteristics for example; a complex object can be derived as a cluster of composite level reciprocations.

In a further example a complex level reciprocation given by a time series of positional characteristic along a clustered

grouping of sequential composite objects (such a reciprocation object derived of sequential nadir points or characteristics of composite level reciprocations of a cluster object at the complex level) can be readily identified and characterized. FIG. 10f shows a superimposed cluster of negative reciprocations of the reciprocation nadirs. Initial fall portions of a severe negative reciprocations of the nadirs of airway instability clusters are shown in FIGS. 10d and 10e and in one presently preferred embodiment these are automatically recognized and indexed relevant magnitude and slope of the decline to provide an output or take action as previous discussed. The present inventors recognized that such a patterns can indicate a high degree of instability of the arousal threshold in relation to a given level of oxygen saturation. This may indicate that other factors are dominating relevant the arousal threshold (such as CO₂). However, this negative reciprocation (like virtually all physiologic reciprocations) is indicative of the function and integrity of a control system. As such a severely negative reciprocation of the nadirs (or the initial decline component as shown, in FIGS. 10c and 10d) can indicate a dangerous attenuation of the control system defining the arousal threshold (as due to narcotics, sedation, a change in sleep stage, or simply a generally less stable arousal control system). In the alternative, a reciprocation of the peak characteristics of such clusters may be identified (or again the initial decline component as shown in FIGS. 10c and 10d). The inventors recognized that this pattern can be indicative of an inadequate and/or attenuated arousal response so that the clustered reciprocations which exhibit the falling peaks are not incomplete. The identification of one or more severe negative reciprocations of the peaks or the decline component alone of such reciprocations can provide important evidence of inadequate arousal response as can be induced by narcotics and/or a superimposed hypo ventilation disorder. Such patterns inside patterns (i.e. objects inside objects) are readily recognized according to the present invention along a single level and across levels, and are automatically recognized and outputted for indication such as a graded alarm or for the automatic taking of action.

Characteristics or index characteristics may be combined with others. For example, a shape characteristic (which contains the slope data set in the time domain) may be combined with a frequency characteristic to provide a time series of a mathematical index of the slopes and the frequencies of the composite objects which can be ordered in an object hierarchy of ascending object data sets and correlated with other object level of other object data sets.

The next level, termed the "global objects level" is then derived from the time series of complex objects. At this level global characteristics are derived from the time series datasets of complex objects (and all of their characteristics). At the global objects level, the processor can identify general specific patterns over many hours of time. An example of one specific pattern which is readily recognizable at this level would be a pattern of regular monotonous occurrence of negative reciprocations alternating with positive reciprocations at the complex level comprised of composite objects, wherein the composite objects are derived of regular reciprocations of negative reciprocations alternating with positive reciprocations (of tidal breathing) at the composite level and wherein the magnitude of both the negative and positive reciprocations at the composite level oscillates in a regular frequency. This pattern is typical of Cheyenne-Stokes Respirations and according to the present invention an expert system examines the pattern of the objects at the composite level,

the complex level, and finally at the global level to provide distinction between this process and the patterns of upper airway instability.

Additional higher levels can be provided if desired as by a "comprehensive objects level" (not shown), which can, for example, include multiple overnight, or post operative monitoring periods wherein a comprehensive object is comprised of a dataset of "global objects".

While FIG. 2 illustrates the levels of object derivations of a ventilation signal, in another example a similar hierarchical architecture can be derived for the timed data set of the pulse waveform (as from an arterial pressure monitor or the plethysmographic pulse) or any of the parameters discussed below. For the plethysmographic pulse the fundamental level is provided by the pulse tracing itself and includes all the characteristics such as ascending and descending slope, amplitude, frequency, etc. This signal also includes the characteristic of pulse area (which, if applied to a precise signal such as the flow plot through the descending aorta, is analogous to tidal volume in the fundamental minute ventilation plot). When the pulse signal is plethysmographic, it is analogous to a less precise signal of ventilation such as nasal pressure or thermister derived airflow. With these less precise measurements, because the absolute values are not reliable indicators of cardiac output or minute ventilation, the complex spatial relationships along and between signals become more important than any absolute value of components of the signal (such as absolute amplitude of the ascending pulse or inspiration curve). In other word, the mathematical processing of multiple signals that are simply related to physiologic parameters (but are not a true measurement of those parameters) is best achieved by analyzing the complex spatial relationships along and between those signals. To achieve this purpose, according to the present invention, as with ventilation, the pulse signal is organized into a similar multi-level hierarchy of overlapping time series of objects. Subsequently these are combined and compared with the processed objects of respiration. The relationships between a plurality of streaming data sets of the ascending objects of FIG. 2 are conceptually represented in FIG. 4 (discussed below) which can include a hierarchy of lime series of streaming objects indicative of a timed drug infusion. A time series of such infusion can include, for example, reciprocations derived from bolus infusions superimposed on a baseline (as with a patient controlled analgesia pump). Here, as discussed, all the time series (included those of the drug infusion) can be ordered into ascending hierarchy and correlated with each of the different levels of other time series.

FIG. 3a shows an exemplary pathophysiologic process associated with a characteristic dynamic pattern of interaction. As discussed previously, this cyclic process is induced by upper airway instability producing derivative reciprocations across a wide range of physiologic parameters. FIG. 3b shows a schematic object mapping at the composite level of two simultaneously measured parameters which are perturbed to produce clusters in response to the upper airway instability cycles of FIG. 3a, this schematic demonstrates the basic cluster pattern of timed plots, the schematic shows the airway instability clusters as negative reciprocations but according to the present invention they can also be recognized as positive oscillations these can also be recognized as positive reciprocations. According to the present invention, upper airway instability and/or ventilation instability is detected by recognizing these cluster patterns along one or more of the timed plots of: EEG frequency and/or amplitude, chest and/or abdomen movement (by impedance, strain gauge or other method), pulse rate and or RR interval (by oximetry, and/or

EKG or other method), pulse amplitude and/or pulse transit time, EMG, oxygen saturation (by pulse oximetry, and/or intravascular venous or arterial oximetry), continuous blood pressure, exhaled carbon dioxide, nasal flow and/or pressure (as by thermister and/or pressure monitoring, or other method), minute ventilation measurements (as by pneumotachometer or other method), snoring (as by pressure monitoring and/or microphone or other method), airway impedance (as by oscillation or other method).

FIG. 3c, and 10a show examples of a monomorphic cluster pattern indicative of airway instability and derived from the mechanism of FIG. 3a, the patterns of which are automatically detected according to the present invention. FIG. 3c shows a raw data set of pulse rate (by oximetry), airflow (by nasal-oral thermister). Another example is shown in FIG. 3d, which now includes a corresponding pulse rate cluster, which is automatically detected according to the present invention. Note the fundamental airflow positive and negative reciprocations in this figure generate larger scale positive reciprocations of airflow recovery (with the patterns shown in FIG. 3c).

In the presently preferred embodiment, the time series of each of these signals are processed into time domain fragments (as objects) and organized into the object levels as previously discussed. For the purpose of organizing and analyzing complex interactions between these corresponding and/or simultaneously derived signals, the same basic ascending process is applied to each signal. As shown in FIG. 3e these streaming objects, many of which overlap, can be seen to conceptually project along a three dimensional time series comprised of multiple levels of a plurality of corresponding signals. A "multi-signal object" is comprised of at least one object from a first signal and at least one object from another signal.

This type of representation is too complex for presentation to hospital personnel but is preferred for the purpose of general representation of the data organization because, at this level of complexity, a complete representation of multiple time series does not lend itself well to a two-dimensional graphical (and in some cases a three dimensional) representation.

To illustrate the complexity ordered by this approach, consider the components of just one of the three simple recovery objects shown in FIGS. 3c and 3e. This single recovery object includes the following exemplary characteristics, each of which may have clinical relevance when considered in relation to the timing and characteristics of other objects;

1. Amplitude, slope, and shape of the oxygen saturation rise event at the composite level.
2. Amplitude, slope, and shape of the ventilation rise event at the composite Level which contains the following characteristics at the fundamental level;
 - Amplitude, slope, time and shape of the inspiration rise object
 - Amplitude, slope, time and shape of the expiration fall object.
 - Frequency and slope dataset of the breath to breath interval of reciprocations (tidal breathing) objects
3. Amplitude, slope, and shape of the pulse rise event at the composite level which contains the following exemplary characteristics at the fundamental level;
 - Amplitude, slope, and shape of the plethsmographic pulse rise event.
 - Amplitude, slope, and shape of the plethsmographic pulse fall event.
 - Frequency and slope datasets of beat-to-beat interval of the pulse rate.

As is readily apparent, it is not possible for a health care worker to timely evaluate the values or relationships of even a modest fraction of these parameters and an expert system applied generally to these parameters rapidly becomes inordinately complex and cumbersome. For this reason the output based on the analysis of these time series of objects are optimally first ordered into a relational, inheritance based object hierarchy, and then subjected to expert system analysis and/or presented in a succinct and interpretive format to the hospital worker as will be discussed.

FIG. 4 provides a conceptual representation of one presently preferred relational data structure of multiple time series, according to the present invention. This representation shows that the many time series of objects are organized into different corresponding streams of objects, which can be conceptually represented as a cylindrical matrix 1, with time defining the axis along the length of the cylinder 1. In this example the cylinder 1 is comprised of the four streams of objects each stream having three levels and these are matched and stored together in a relational database, object database or object-relational database. Each streaming set of objects from a single signal or source (e.g. airflow or oximetry, as in a matrix of physiologic signals) is represented in the main cylinder 1 by a smaller cylinder (2,3,4,5) and each of these smaller cylinders is comprised of a grouping of ascending object levels (6,7) as will be described. One important advantage of organizing the data in this way is that each object from each grouping can be readily compared and matched to other objects along the grouping and can further be compared and matched to other object from each other grouping. Objects occurring at one lime in one level encapsulate the objects at lower levels so that objects of a first grouping can be readily compared to objects occurring at another time and at another level of at least one other grouping. Complex patterns and subtle relationships between interactive and interdependent streams of objects can be readily defined by applying an expert system or by manually or automatically searching the matched object streams as will be discussed. This allows for the recognition of the "Dynamic Pattern of Interaction" (DPI) between data set objects. The recognition of a specific DPI occurrence falling within a specified range is used to determine the presence and severity of a specific of a biologic or physical process.

One of the longstanding problems associated with the comparison of outputs of multiple sensors to derive simultaneous multiple time series outputs for the detection of pathophysiologic change is that the accuracy and/or output of each sensor may be affected by different physiologic mechanisms in different ways. Because of this, the value of matching an absolute value of one measurement to an absolute value of another measurement is degraded. This is particularly true if the measurement technique or either of the values is imprecise. For example, when minute ventilation is measured by a precise method such as a pneumotachometer, then the relationship between the absolute values of the minute ventilation and the oxygen saturation are particularly relevant. However, if minute ventilation is being trended as by nasal thermister or nasal pressure monitoring or by chest wall impedance, then the absolute values become much less useful. However, according to one aspect of the present invention the relationship between pluralities of simultaneously derived signals can be determined independent of the relationships of the absolute values of the signals. In this way, simultaneously derived signals can be identified as having convergence consistent with physiologic subordination or divergent shapes consistent with the development of a pathologic relationship or inaccurate data acquisition.

As noted, with physiologically linked signals, a specific occurrence or magnitude of change in one signal in relationship to such a change in another signal may be more important and much more reproducible than the absolute value relationships of the respective signals. Using the teachings of the present invention, two simultaneously acquired and physiologically linked signals are compared by the microprocessor over corresponding intervals by matching the respective objects (which can be applied at multiple levels) between the signals. As discussed, a primary signal such as airflow is ordered into composite and complex objects along with a contemporaneously measured secondary signal such as oxygen saturation as by the method and system discussed previously. For example, the composite level of airflow can be a of reciprocation objects derived from a fundamental level of amplitude and/or frequency of the tidal airflow as by thermister or pressure sensor, or another plot, which is indicative of the general magnitude of the timed tidal airflow. In the presently preferred embodiment, a plot at the fundamental level of a mathematical index (such as the product) of the frequency and amplitude is preferred, because such an index takes into account the important attenuation of both amplitude and frequency during obstructive breathing. Furthermore, both the frequency and amplitude are often markedly increased during the recovery interval between apneas and hypopneas.

Although the exact delay between the signals may not be known, the processor can identify this by identifying the best match between the object sets. In the preferred embodiment, this "best match" is constrained by preset limits. For example, with respect to ventilation and oximetry, a preset limit could be provided in the range of 10-40 seconds although other limits could be used depending on the hardware, probe site and averaging intervals chosen. After the best match is identified, the relationships between the signals are compared (for example, the processor can compare the a rise or fall event of oxygen saturation to a rise or fall event of ventilation as shown in FIG. 6). In this preferred embodiment, each such event is compared. It is considered preferable that the objects of each respective parameter relate to a similar duration. With respect to airflow, calculation of the magnitude value of airflow may require sampling at a frequency of 25 hertz or higher, however, the sampling frequency of the secondary plot of the magnitude value of the index can, for example, be averaged in a range of one hertz to match the averaging interval of the data set of oxygen saturation.

It is not necessary that such a fundamental level plot reflect exactly the true value of the minute ventilation but rather, it is important that the plot reflect the degree of change of a given level of minute ventilation. Since these two signals are physiologically linked, an abrupt change in the primary signal (airflow) generally will produce readily identifiable change in the subordinate signal (oxygen saturation). As previously noted, since the events which are associated with airway collapse are precipitous, the onset of these precipitous events represent a brief period of rapid change which allows for optimal detection of the linkage between the primary signal and the subordinate signal.

The signals can be time matched by dipole slopes at the fundamental level. In addition, in one preferred embodiment, the point of onset of precipitous change is identified at the composite object level of the primary signal and this is linked to a corresponding point of a precipitous change in the composite object level of the subordinate signal. This is referred to herein as a delta point. As shown in FIGS. 3c, 5, and 6, a first delta point is identified in the primary signal and in this example is defined by the onset of a rise object. A correspond-

ing first delta point is identified in the subordinate signal and this corresponds to the onset of a rise object in the subordinate signal. A second delta point is identified which is defined by the point of onset of a fall object in the primary signal and which corresponds to a second delta point in the subordinate signal defined by the onset of a fall event in the secondary signal. The point preceding the second delta point (the "hyperventilation reference point") is considered a reference indicating an output associated with a degree of ventilation, which substantially exceeds normal ventilation and normally is at least twice normal ventilation. When applying airflow as the primary signal and oximetry as the subordinate signal, the first delta point match is the most precise point match along the two integrated waveforms and therefore comprises a ("timing reference point") for optimally adjusting for any delay between the corresponding objects of the two or more signals. The mathematical aggregate (such as the mean) of an index of the duration and slope, and/or frequencies of composite rise and fall objects of the fundamental level of tidal ventilation along a short region adjacent these reference points can be applied as a general reference for comparison to define the presence of relative levels of ventilation within objects along other portions of the airflow time series. Important fundamental object characteristics at these reference points are the slope and duration of the rise object or fall object because these are related to volume of air, which was moved during the tidal breath. The fundamental objects comprising the tidal breaths at the reference hyperventilation point along the composite level are expected to have a high slope (absolute value) and a high frequency. In this way both high and low reference ranges are determined for the signal. In another preferred embodiment, these points can be used to identify the spatial shape configuration of the rise and fall objects at the fundamental level during the rise and fall objects at the composite level.

Using one presently preferred method, a first object (such as is shown in FIG. 5) can then identified in the primary signal (such as, for example, airflow) at the composite object level between the first delta point and the second delta point which is designated a recovery object. As also shown in FIG. 5 the matched recovery object (for example oxygen saturation) is also identified in the subordinate signal as the point of onset of the rise object to the point of the onset of the next subsequent fall object. In the preferred embodiment, the recovery object is preceded by the apnea/hypopnea object which is defined by the point of onset of the fall object to the point of onset of the next rise object in both the primary and subordinate signals.

Once the signals have been sufficiently matched at the one object level they can be further matched at another object level. When the objects are matched, the baseline dynamic range relationship between the signals can be determined. This baseline range relationship can be a magnitude value relationship or a slope relationship. The signals can then be monitored for variance from this baseline range, which can indicate pathology or signal inaccuracy. The variance from baseline can be, for example, an increase in the relative value of ventilation in relation to the oximetry value or a greater rate of fall in oxygen saturation in relation to the duration and/or slope of fall of ventilation. In another example, the variance can include a change from the baseline delay between delta points along the signals or a change in the direction (polarity) of one signal in relation to the baseline relationship for example two signals which formally moved in the same direction (after adjusting for a delay) may be recognized to exhibit variance by moving in opposite directions and the occurrence of this variance from a previously identified dynamic relationship (or a pre specified dynamic relationship range) Upon

such recognition, according to the present inventor, the processor can be programmed to take action such as lock out a medication, adjust the flow of oxygen, change the positive pressure or tidal volume of a ventilator, or provide an indication, such as an alarm.

According to the present invention, clusters of signal perturbation induced by even mild hypopneas can generally be reliably recognized by their cluster patterns utilizing with only a single parameter without setting up a priori and arbitrary rules (such as a 50% reduction in the airflow signal). In addition, when significant signal noise or reduced gain is present reducing cluster recognition in one signal, the objects based system can combine matched clusters within a time series of multi-signal objects in the presence of sub optimal signals by providing a scoring system for sequential objects across a wide range of parameters. FIGS. 7, and 8 show schematics of the basic cluster matching for two parameters in situations wherein sub optimal signals may be present although many more parameters may be combined in this way. In one example, the matched clusters can be paired timed datasets of airflow and oximetry include a matched sequence of negative reciprocations in the airflow signal and corresponding delayed negative reciprocation in the oximetry signal. One exemplary method of achieving match with an incomplete set of matching objects in one of the signals follows; Each reciprocation at the composite level is defined by a set of coupled rise and fall objects meeting criteria and occurring within a predetermined interval of each other (as discussed previously). The occurrence of reciprocation in either dataset meeting all criteria is given a score of 1.

The reciprocations are counted in sequence for each matched cluster object. For the purpose of illustration, according to the present invention, the occurrence of a score of 3 in anyone signal (meaning that a continuous sequence of 3 reciprocations meeting criteria have occurred within a specified interval) provides sufficient evidence to identify a cluster object. When two simultaneous signals are processed, a total score of 4, derived from adding the number of reciprocations meeting criteria in each signal, is sufficient to indicate the presence of a cluster object. In this manner the cluster is continued by a sequential unbroken count greater than 3 with one signal, or greater than 4 with two signals. Once the presence of a cluster object has been established along the time series, at any point along the cluster object the sequential count along one signal can be converted to a continuation of the sequential count along another signal allowing the cluster object to continue unbroken. The failure of the occurrence of a cycle meeting criteria within either signal within a specified interval (for example about 90-120 seconds, although other intervals may be used) breaks the cluster object. A new cluster object is again identified if the count again reaches the thresholds as noted above. It can be seen that this scoring method takes into account the fact that artifact often affects one signal and not another. Therefore if either signal alone provides a sufficient score, the presence of a cluster object is established. In addition, the effect of brief episodes of artifact affecting both signals is reduced by this scoring method. In this way, artifact, unless prolonged, may cause the cluster object to be broken but as soon as the artifact has reduced sufficiently in anyone or more signals the process of scoring for a new cluster object will restart. The skilled artisan will recognize that many other such scoring or artifact rejecting methods using two linked signals can be derived within the scope of this teaching.

When applied, one preferred digital pattern recognition program for automatically detecting, characterizing and

indexing the severity airway instability proceeds in several phases, which need not be in the illustrative sequence, listed below:

1. Various types of decline and rise objects are identified at the composite level.
2. Various types of negative and positive reciprocations are identified at the composite level.
3. Various types of clusters of reciprocations are identified in the complex level.
4. Various types of reciprocations of clustered reciprocation object characteristics (e.g. nadirs) are identified,
6. Reciprocations at the fundamental level are analyzed within specific objects at the composite level.
7. Objects of one channel are compared to objects of another channel (if multiple time series of objects are rendered).
8. An expert system is applied to recognize a pattern of objects indicative of a diagnosis.
9. The relationship between the events, reciprocations, and complex patterns is calculated and outputted.
10. The severity of the pathophysiologic perturbation is determined
11. A textual alarm and/or other signal, which may be graded based on severity is outputted
12. Treatment is automatically modified to adjust or prevent medication infusion or to eliminate the cluster
13. The process is then repeated with each addition to the dataset in real-time or with stored timed datasets.

A mathematical representation of a basic iterative process of waveform object segmentation according to the present invention is described in detail in the co-pending application entitled System and Method for Identifying Dynamic Patterns of Interaction, the disclosure of which is incorporated by reference as if completely disclosed herein and an exemplary mathematical reference listing is provided in FIG. 20a-20c.

- These basic algorithms are particularly suited to identify monomorphic clusters and which, because of the precipitous nature of the operative pathophysiology driving the airway instability cycle, are largely comprised of two basic types of events (unipolar rise and unipolar fall), and a basic type of reciprocation (a simple negative or positive reciprocation) and a single cluster type (as a collection of negative or positive reciprocations). As will be shown many basic pathophysiologic processes are comprised of this type of simple reciprocations and the basic embodiment suffices to characterizing them.

The present inventors have described clusters comprised of reciprocations of varied morphology as polymorphic (an example of such a cluster is shown in figure 10b). For the purpose of the presently preferred embodiment, with respect to the oximetry time series, a polymorphic cluster is a cluster of reciprocations, which contains at least two reciprocation morphologies and wherein the morphologies have differences other than simple variations in scale. In one embodiment, with respect to the oximetry time series, variation of the nadirs of the negative reciprocations is considered still consistent with monomorphic clusters. However in this embodiment, negative reciprocations of the peaks exceeding a 6% variation is considered indicative of a polymorphic cluster. Many modifications and different definitions can be applied to differentiate polymorphic from monomorphic clusters. In one preferred embodiment, the morphology of different reciprocation types is selectable by selecting the characteristics of the events from which they are derived (the reciprocations inheriting these characteristics). A monomorphic cluster may degenerate into a polymorphic cluster, and again this is recognized by identifying the presence of new types of reciprocations or events developing along the cluster. For

example the occurrence of brief reciprocations with progressively falling peaks coupled with prolonged reciprocations with prolonged decline components would be one example of morphology of a polymorphic cluster. The present inventors recognized that reciprocation morphology was a window into the integrity and function of the control system. For this reason, the automatic recognition, according to the present invention provides an important function since the presence of a polymorphic cluster can indicate a control system which is highly unstable, severely attenuated, the presence of competing control systems (which can indicate partial attenuation of a primary controller and salvage by a secondary controller, or it can indicate that multiple pathophysiologic process are overlapping).

The present inventors have discover that, at least in one population of patients with airway instability, the basic monomorphic pattern dominates and polymorphic patterns occur in less than 10% of the patients. However, this may increase with narcotic administration or with select subgroups of the severe obesity (at risk for obesity hypoventilation syndrome) or those with COPD, or CHF. The present inventors have discovered that the automatic recognition of complex polymorphic clusters can be useful to determine the stability and integrity of ventilation control and the probability of success of automatic CPAP titration. This is an important discovery because primary care physicians have been reluctant to institute automatic CPAP in the home without attendance because the probability of success for a given patient cannot be known a priori. The present inventors recognized that the presence of polymorphic clusters and/or monomorphic clusters superimposed on other reciprocations (an occurrence which develops, for example, when airway instability is superimposed on other cardiovascular and pulmonary co morbidities) have a lower probability of successful automatic CPAP titration and are therefore may best titrated in a sleep laboratory or other attended setting where a trained attendant can adjust treatment. They also recognized that polymorphic reciprocations are often best treated with multilevel ventilation because they often indicate an incomplete, or delayed recovery, which is often best supported by ventilation rather than simple CPAP.

According to the present invention, a automatic CPAP titration which can use any of a range of algorithms for CPAP adjustment, as are known in the art, upon recognition by the processor of polymorphic clusters, or the presence of a decline in a time series of the peaks of clusters (as for example in the oximetry signal), and/or the failure to abort clusters, the processor is programmed to automatically converts the CPAP to a bi level ventilator. According to the present invention, this can be achieved by automatically lowering the pressure on exhalation by for example 2-4 cm H₂O and maintaining the original pressure on inhalation. Alternatively, the processor can trigger the addition of higher pressure on inspiration, for example 2 cm H₂O, above the original continuous pressure level and then titration of the inspiratory pressure and or expiratory pressure until the cluster is aborted. According to the present invention, if pathophysiologic divergence is identified with a fall in oxygen saturation in relation to a rise in ventilation (as discussed in detail in the aforementioned co-pending application) this recognition can be used to automatically warn of the potential need for oxygen or to automatically initiate or increase oxygen instead of increasing the CPAP or Ventilation. Also the development of pathophysiologic divergence in association with upward titration can be used to reduce the pressure to their original levels. Automatic conversion to ventilation or increasing ventilation upon the occurrence of polymorphic clusters and/or when the cluster peaks exhibit a significant decline or automatically aborting

the titration and/or providing an output indication that the patterns indicate that attended titration may be preferable provides a more physiologically focused titration of therapy which can substantially improve the efficacy and sale of automatic positive pressure treatment devices.

According to the present invention, a wide range of variations of events, reciprocations and clusters are built from simpler objects and this provides the ability to identify a wide range of physiologic phenomena without losing information gained by aggregating specific types of such phenomena. For this reason the presently preferred time domain analysis starts with a basic segmentation process upon which is built a more complex characterization. The more complex physiologic occurrences are better represented programmatically than mathematically and this representation follows. Because the wide range of permutations causes marked complexity, the present inventors recognized that an effective framework and methodology was required to address the complexity of this type of software system. In the presently preferred embodiment object oriented time series segmentation, in the time domain, into an inheritance based relational hierarchy allows recognition and characterization a very broad range of real-world phenomena including complex, interactive physiologic datasets.

The diagram of FIG. 11 represents both the real-world objects (e.g. reciprocations) and support objects for the rapid creation, rendering of such object to a graphical user interface and persisting such objects to relational database and/or a hierarchical data store (e.g. eXtensible Markup Language (XML) documents). This diagram is only representative and objects for accomplishing such rendering and persisting are not shown and may according to the present invention vary greatly depending upon the operating environment of the application.

The core objects of the presently preferred analysis are shown in FIG. 12. Here a case represents a single timed data set (such as 12 or 24 hours halter monitoring period, one night in the sleep lab or hospital, or a variable post operative period) outputted from the monitored patient and may contain any number of channels. A channel is a single data stream (e.g. oximetry). A time series (as described earlier) is a set of contiguous data points derived from a particular physiologic signal (e.g. oximetry). As shown, a case is any number of channels and a channel contains a single time series. These raw data datasets are then converted (as described earlier) into objects of increasing complexity events, reciprocations and clusters (of events and/or reciprocations). Each of these objects are representations of a segment of the wave (as designated by their reference to the WaveSegment object) but contain much more information than simply the raw data as provided by their context within the analysis (their relationship to other objects). It should be noted that the relationship to predecessor objects is maintained to provide for the layered complexity as described earlier.

Since the creation of hundreds of thousands of dipole objects can hamper the acquisition of the analysis in a real-time environment, in the presently preferred embodiment, the logical concept of the dipole object has been encapsulated within the time series to improve performance in a real time environment.

Correlated events provide the basic mechanism for identifying relationship between channels. The aggregation of these objects within a case analysis object provides the ability to interpret broad, intra and inter-channel trends while also providing access to the large amount of simple objects and raw data from which those trends were derived. according to the present invention this presently preferred structure in the

context of an object-oriented programming language that provides the power to readily apply a broad range of expert system based comparisons, create indices, alarms, graphical representations and other human facing mechanisms for interpretation and analysis. FIG. 12 shows the basic relationships of the objects created. In a completed analysis potentially thousands of such objects are created and related to each other. Further, within each object a wide range of rich functionality is exposed. As an example, the time series object exposes the following functions:

TimeSeriesKey
 SampleRate
 UpperLimit
 LowerLimit
 NumberOfPoints
 StartTime
 CreateTime
 StartPointPosition
 EndPointPosition
 Duration
 EndTime
 MeanValue
 MaxValue
 MinValue
 ValueAtPoint
 SumAtPoint
 StartSequentialLoad
 SequentialLoadPoint
 TimeAtPoint
 DipolesToTimeSpan
 TimeSpanToDipoles
 TimeToNearestPoint
 CompareTime
 ComparePointPosition
 DipolePointPosition1
 DipolePointPosition2
 DipoleDuration
 NumberOfDipoles
 DipoleChange
 DipoleSlope
 DipolePolarity
 MeanValueOfSegment
 MinValueOfSegment
 MaxValueOfSegment
 DipolePositionAfter
 ExtractKey
 PointsNeedToBeSaved

As a further example, the following is a list of functions available for a cluster object (this does not include the ability of that object to access any functionality of the reciprocations, events and time series which are related to the cluster object):

NumberOfPoints
 NumberOfDipoles
 StartPointPosition
 EndPointPosition
 StartDipolePosition
 EndDipolePosition
 StartTime
 Duration
 EndTime
 MinValue
 MaxValue
 MeanValue
 ChangeAccordingToEndPoints
 SlopeAccordingToEndPoints
 CompareTime
 ComparePointPosition

ClusterType
 ClusteredReciprocations
 MeanStartEventDuration
 MeanEndEventDuration
 MeanStartEventMagnitude
 MeanEndEventMagnitude
 MeanStartEventSlope
 MeanEndEventSlope
 MeanReciprocationMaxValue
 MeanReciprocationMinValue
 MeanReciprocationMagnitude
 MeanReciprocationDurationRatio
 MeanReciprocationMalagnitudeRatio
 MeanReciprocationSlopeRatio
 MeanRecoveryDuration
 MeanRecoveryRatio()

FIG. 13 shows the preferred support mechanisms for the creation of the analysis. In the presently preferred embodiment the analysis definition is separated from the analysis itself allowing for the efficient proliferation of patient data and analysis while maintaining a small set of metadata. Although the analysis and transforms may be fixed for application in the hospital, this flexibility allows researchers the ability to create any number of analysis definitions to apply to various patient types, and/or disorders.

As shown, in the above structure a requesting system will create an analysis request and submit it to the case analysis director. The director is a dispatcher object that oversees the analysis process while delegating the actual processing to other objects. The most important of these delegates is the channel analysis builder. This object performs the basic algorithms described above against the respective time series to produce the aforementioned events, reciprocations, clusters and the relationships between them.

During this process data structures for providing fast access by point and dipole are created as point and dipole maps respectively. These objects provide single step access to all objects tied to a particular point and/or dipole. This supports a high level of interactivity (e.g. mouse over actions) in a graphic user interface (e.g. a Microsoft Windows application).

Analysis requests may not be comprehensive and therefore further analysis can be requested to the case analysis director. This ability to provide partial analysis further enhances performance by allowing a researcher or physician to specify the particular aspects of the analysis he/she finds useful.

The channel integrator performs intra-channel analysis to create event correlations. These correlations (and the aggregations thereof) provide an integrated view of all channels within a case.

FIG. 14 shows one preferred data acquisition and transformation system for preceding the analysis. The time series acquisition and transformation system of FIG. 14 provides for a flexible interface (real-time and otherwise) to data providers and data stores. The import and transform subsystems follow a similar design pattern of a request, a director and a set of delegate objects to perform the required operations. The present embodiment allows researchers the ability to readily transform (e.g. filter, smooth, integrate) the time series before performing analysis. The results of these transformations can then become a channel within the case itself on which analysis can be performed in the same aforementioned way. These channels can be, for example, a real-time time series of a calculated index of two or more signals such as airflow and oximetry to quickly identify pathophysiologic divergence of these normally linked parameters in postoperative patients or those at risk for pulmonary embolism or sepsis. In another

example the new channel can be a real-time integration of oximetry and pulse to improve automatic severity indexing during monitoring for neonatal apnea).

Of course, the transformation itself can be a quite complex process and the transform has a substantial impact on the waveform morphology and relationships. This has been a significant problem with standard hospital monitoring systems (such as pulse oximeters). Despite the importance of the effect a transform has on time series morphology and alarm reliability the monitoring industry has not standardized to any transform and many oximeters do not even provide documentation relevant the transform applied to generate the time series. The present inventors recognized that, in the interest of providing optimal patient care, the transform needs to be understood by the physician and researcher so that the time series outputs and all algorithms performed are clearly identified and/or can be explicitly requested. For this purpose, the present inventors created a nomenclature for explicit representation of an transformations available.

FIG. 17 shows one presently preferred nomenclature for the exemplary parameters of airflow, pulse, and oxygen saturation. Illustrative examples of designation by this nomenclature are shown in FIG. 18.

According to the present invention, objects at the composite level encapsulate the objects from which they are derived at the fundamental level. For this reason a recovery object recognized at the composite level in one parameter can be used to specify a region for comparison of sequential objects (such as reciprocations) at the fundamental object level in the same parameter or in matched recovery objects along another parameter. For example, upon recognition of the presence of a recovery object (where it is anticipated that the ventilation effort will be high) the ratio of the slope of all (exhalation) objects and rise (inhalation) objects at the fundamental level can be compared within the recovery object and the time series derived from a continuous calculation this ratio can be plotted at it too analyzed by object mapping if desired. During upper airway obstruction, the inspiration is slowed to a greater degree than exhalation. The magnitude change of inspiratory slowing and/or amplitude and/or ratio during the clusters of apneas provides an index of the magnitude of upper airway narrowing (which slows inhalation during the clustered apnea/hypopnea objects). However, during the recovery object or at the "hyperventilation reference point", the upper airway should be wide open for both inhalation and exhalation and this can be used as a reference because, during this time. Because the recovery objects encapsulate the fundamental reciprocation objects from which it is derived, the absolute slope, magnitude, frequency and amplitude, of the fundamental objects during recovery can then be compared to provide a reference for the absolute slope magnitude, frequency and amplitude of the fundamental objects during other times along the night to provide an indication of upper or lower airway narrowing.

These encapsulations allow ready exploitation that certain regions along a multi-signal object (as within an airway instability cluster) have a very high probability of association with various levels of ventilation. According to the present invention, the objects defining those regions can then be used as a reference or as an opportunity to examine for the effects of a given level of ventilation effort on the flow characteristics of the encapsulated reciprocations. Patients with obstructive sleep apnea are expected to have a hill in the slopes of fundamental inspiration objects during decline objects at the composite level indicative of upper airway narrowing and/or occlusion. Also, as shown in FIG. 7, patients with asthma or chronic obstructive lung disease may have a reduced slope of

the exhalation when compared to the slope of inhalation during the rise objects between apneas at the base level. According one embodiment of the present invention, the ratio of the slope of inhalation objects at the fundamental level is compared to the slope of the exhalation objects at the fundamental level and this can be plotted as a time series for object based analysis. Patients with simple, uncomplicated obstructive apnea will have clusters of increasing slope ratios with the ratio rising to about one during the recovery objects. Patients with combined obstructive apnea and asthma or chronic obstructive lung disease will have increased ratios during the recovery objects into the range of 2-3 or greater, indicating the development of obstructive lower airways during the rapid breathing associated with recovery.

Another example of object processing at the fundamental object level, according to the present invention, includes the processor-based identification of fluttering of the plateau on the pressure signal to recognize partial upper airway obstruction. During the nasal pressure monitoring a fluttering plateau associated with obstructive breathing often occurs intervening a rise event and a fall event of tidal breathing. Since the plateau objects are easily recognizable at the fundamental level and readily separated using the present object recognition system the plateau can be processed for the tiny rise and fall objects associated with fluttering and the frequency of these objects can be determined. Alternatively, a Fourier transform can be applied to the plateau objects between the rise and fall events of the nasal pressure signal to recognize the presence of fluttering or another method can be utilized which provides an index of the degree of fluttering of the plateau objects.

Since reduced effort also lowers the slope of exhalation and inspiration, the configuration (as defined by the slope dataset of the dipoles defining the fundamental objects of both inspiration and expiration at the reference objects) can be applied as reference fundamental object configurations defining the presence of hyperventilation or hypopnea. This process is similar to the selection process for identifying search objects described earlier but in this case the input region is pre-selected. In an example, the range of characteristics of the objects at the fundamental level derived from one or more tidal breaths occurring prior to the second airflow delta point can be used to designate a reference hyperventilation objects range. Alternatively the object based characteristics, defined by of the range of characteristics of the objects derived from one or more tidal breaths occurring prior to the first airflow delta point can be used designate a reference hypopnea objects range. The processor can then automatically assess object ranges along other points of the tracing. In this way the processor can apply an artificial intelligence process to the identification of hypopneas by the following process:

1. Identify the region wherein a hypopnea is expected (as for example two to three tidal breaths prior to the first airflow delta point).
2. Select this as a region for objects processing to define the characteristics of hypopneas in this patient.
3. Process the region using the slope dipole method to define the range of fundamental objects comprising the target region.
4. Compare the identified range of objects to other analogous objects along to tracing to identify new objects having similar characteristics.
5. Using the criteria derived from the objects defining the target region search the processed waveform for other regions having matching sequences of new objects and identifies those regions.

6. Provide an output based on said identification and/or take action (e.g. increase CPAP) based on said identification.

In one embodiment, the multi-signal time series output is placed into a format particularly useful for demonstrating events to hospital personal especially for teaching purposes. In this format the output controls an animation of multiple objects which are shaped into an animated schematic of the as the physiologic system being monitored. The animation moves over time and in response to the signals and one preferred embodiment the type of signals (or the reliability of such signals) determines which components of the schematic are "turned on" and visible. One example includes a multi-signal object defined by outputs of airflow, thoracic impedance, oximetry, and blood pressure rendering set of a connected set animation objects for the lungs, upper airway, lower airway, heart, and blood vessels which can be animated as;

Each inspiration causing an animated enlargement of the lungs tracking the inspiration slope,

Each expiration causing an animated reduction in size of the lungs tracking the expiration slope,

Each animated systolic beat of the heart tracks the QRS or upstroke of the oximetry output,

The color of the blood in the arteries and left heart tracks the oxygen saturation,

The diameter of the lower airway (a narrowing diameter can be highlighted in red) tracks the determination of obstruction by the slope ratio in situations of hyperventilation (as discussed previously),

The patency of the upper airway (a narrowing or closure can be highlighted in red) tracks the determination of upper airway obstruction (for example the airway is shown as opening and closing in clusters when ventilation effort (as by chest wall movement) is identified in clusters with absent nasal flow.

This provides "physiologic animation" which can be monitored in real-time and which can also be derived and reviewed from the stored multi-signal objects at variable time scales. This embodiment of the present invention provides a quickly, easily understood and dynamic animated output of a highly complex, interactive time series derived from a patient. The animation can be reviewed at an increased time lapsed to speed through evolution of a given patients outputs or can be slowed or stopped to see the actual global physiologic state at the point of onset or termination of a given pathophysiologic perturbation.

Particularly for use in the hospital, a graded indicator or alarm can be provided, indicative of the severity of the clusters and of air way or ventilation instability. Since very mild clustering may simply represent the effect of moderate sedation, and not, therefore, represent a cause for great concern (although it is important to recognize that it is present). Such a clustering could be identified with a single bar or test warning, whereas more severe clustering would generate a larger warning and, if very severe, an auditory alarm. When the clustering becomes more severe and demonstrates greater levels of desaturation and/or shorter recovery intervals the bar can be doubled.

According to another aspect of the present invention, a change in one or more time series components of the multi-signal object can be used to change the processing algorithm of a time series component of the multi-signal object. In an example, the recognition of airway instability is enhanced by improved fidelity of the timed waveform (as with pulse oximetry). FIG. 19 shows one preferred method, according to the present invention, of improving the general fidelity of the

entire timed waveform of S_pO_2 for enhanced pattern & cluster recognition in an environment where the patient, at times, has motion and, at other times, does not. It is optimal, for example, in monitoring oximetry for the probe to be placed on a portion of the patient, which is not associated with motion. However, in most cases, this is unrealistic and motion is commonly associated with routine clinical oximetry monitoring. It is well known that motion results in a fail in the saturation value, which is generated by the oximeter. Multiple theories for the cause of the fall have been promulgated. Several corporations, including Masimo, and Nellcor had developed algorithms, which can be used to mitigate the effect of motion on the accuracy of the output. However, such algorithms can include a significant amount of signal averaging, generally four seconds or more. This can result in significant smoothing of the waveform and reduces the fidelity of the waveform. Furthermore, it attenuates patterns of minor desaturations, which can be indicative of airway instability, and clusters of hypopneas associated with variations in airway resistance. As discussed in the aforementioned patents and patent application, even minor desaturations when occurring in clusters can be strong evidence for airway or ventilation instability and it is important to recognize such desaturations. Unfortunately, averaging intervals, especially those exceeding four seconds or more can result in attenuation of these desaturations and, therefore, hide these clusters so that the airway instability may not be recognized. However, motion itself results in artifact, which can simulate desaturations. Although such artifact is not expected to occur in typical cluster pattern, the presence of motion artifacts significantly reduces the value of the signal as an index of oxygen saturation and airway instability.

The present invention thereby provides for more optimal continuous fidelity of the waveform through both motion and non-motion states. As illustrated in FIG. 16, when the motion time series output suggests that substantial motion is not present, such as deep sleep or sedation, wherein the extremity is not moving, long averaging smoothing algorithms or motion mitigation algorithms are not applied to the oxygen saturation and plethysmographic pulse time series. In the alternative, if the series indicates motion then these motion mitigation algorithms are applied. The variable application of averaging based on identification of the absence or presence of motion provides optimal fidelity of the waveform for monitoring airway instability.

Those skilled in the art will recognize that, the information provided from the data and analysis generated from the above-described system can form the basis for other hardware and/or software systems and has wide potential utility. Devices and/or software can provide input to or act as a consumer of the physiologic signal processing system of the present invention's data and analysis.

The following are examples of presently preferred ways that the present physiologic signal processing system can interact with other hardware or software systems:

1. Software systems can produce data in the form of a waveform that can be consumed by the physiologic signal processing system.
2. Embedded systems in hardware devices can produce a real-time stream of data to be consumed by the physiologic signal processing system.
3. Software systems can access the physiologic signal processing system representations of populations of patients for statistical analysis.
4. Software systems can access the physiologic signal processing system for conditions requiring hardware responses (e.g. increased pressure in a CPAP device),

signal the necessary adjustment and then analyze the resulting physiological response through continuous reading of the physiologic signal processing system data and analysis.

It is anticipated that the physiologic signal processing system will be used in these and many other ways. To facilitate this anticipated extension through related hardware and software systems the present system will provide an application program interface (API). This API can be provided through extendable source code objects, programmable components and/or a set of services. Access can be tightly coupled through software language mechanisms (e.g. a set of C++ modules or Java classes) or proprietary operating system protocols (e.g. Microsoft's DCOM, OMG's CORBA or the Sun Java Platform) or can be loosely coupled through industry standard non-proprietary protocols that provide real-time discovery and invocation (e.g. SOAP [Simple Object Access Protocol] or WSDL [Web Service Definition Language]).

In the preferred embodiment the physiologic signal processing system with the API as defined becomes a set of programmable objects providing a feature-rich development and operating environment for future software creation and hardware integration.

FIG. 19a-19e presents one presently preferred programming code for integrating a plurality of signals and identifying dynamic patterns of interaction. The program is particularly suited for physiologic signals but can be used to track and identify relationships between a broad range of signals to identify specific patterns or to search for patterns. Although the listed program is coded for contiguous points for efficiency, according to the present invention, the time series data points need not be contiguous and indeed as discussed with physiologic data sets, noncontiguous points are converted into a time series when nadirs or peaks of reciprocations are plotted to identify timed patterns of variation in these parameters. The present invention is applicable to detect dynamic patterns and relationships particularly in the time domain in the along and between one or a plurality of financial time series such as stock prices or stock indexes, vibration time series, time series of sound, air movement, temperature, populations, and other dynamic processes where it may be desirable to identify, along complex data sets, known or unknown dynamic patterns of interaction.

Although the presently preferred embodiments have been described, which relate to the processing of physiologic signals, it is also critical to recognize the present streaming parallel objects based data organization and processing method can be used to order and analyze a wide range of dynamic patterns of interactions across a wide range of corresponding signals and data sets in many environments. The invention is especially applicable to the monitoring of the variations or changes to a physical system, biologic system, or machine subjected to a specific process or group of processes over a specific time interval.

Many other additional parameters may be added and will become evident to those skilled in the art in association with the application of the present invention and these are included within the scope of this invention. Those skilled in the art that various changes and modifications can be made without departing from the invention. While the invention has been described in connection with what is presently considered to be the most practical and preferred embodiments, it is to be understood that the invention is not to be limited to the disclosed embodiments, but on the contrary, is intended to cover various modifications and equivalent arrangements included within the spirit and scope of the appended claims.

The invention claimed is:

1. A monitoring system, comprising:

a monitor configured for receiving input relating to patient physiological pulse oximetry or exhaled CO2 parameters and storing data related to the parameters, the monitor comprising:

a processor programmed for analyzing the data to detect and display an SPO2, a pulse, or an exhaled CO2 pattern and to determine a severity of said pattern, the pattern comprising clustering of reciprocations of SPO2, pulse, or exhaled CO2 data due to corresponding clustering of sleep apnea events; and

at least one processor programmed for communicating with a drug infusion pump controller to discontinue drug infusion responsive to the severity of said pattern.

2. The system of claim 1, wherein data related to the parameters comprises pulse oximetry data.

3. The system of claim 1, wherein the pattern comprises an oxygen saturation pattern indicative of ventilatory instability.

4. The system of claim 1, further comprising a graphical indicator that changes in relation to the occurrence or the severity of said pattern.

5. A method, comprising:

receiving input relating to patient physiological parameters and storing data related to the parameters;

detecting and displaying, with a processor, an oxygen saturation, a pulse, or an exhaled CO2 pattern, the pattern comprising clustering of reciprocations of the oxygen saturation, the pulse, or the exhaled CO2 due to corresponding clustering of sleep apnea events indicative of ventilatory instability;

determining, with the processor, a severity of the pattern; and

communicating, via the processor, with a drug infusion pump controller to discontinue drug infusion responsive in real-time or near real time, at least in part, to said determining of a severity of said pattern.

6. A system, comprising:

a sensor configured for sensing patient physiological parameters comprising pulse oximetry or exhaled CO2 parameters;

a monitor programmed for receiving input data from the sensor related to the patient physiological parameters and storing the data related to the parameters, the monitor comprising:

a pattern detection and display feature programmed for analyzing the data to detect and display a pattern in the data, the pattern comprising clusters of reciprocations of SPO2, pulse, or exhaled CO2 due to corresponding clustering of sleep apnea; and

at least one processor programmed for communicating with a drug infusion pump controller to discontinue drug infusion responsive to said detecting of said pattern.

7. The system of claim 6, wherein the sensor comprises a pulse oximetry sensor.

8. A monitoring system, comprising:

a monitor for receiving input data relating to patient physiological parameters and storing the data related to the patient physiological parameters, the monitor comprising;

a processor comprising a pattern detection and display feature programmed for analyzing and displaying the data to detect and display a pattern in the data, the pattern comprising a cluster of reciprocations, the reciprocations being defined by a fall, a nadir, a rise, and a rise peak;

a pattern qualification feature programmed for determining
if the detected pattern is due to a ventilatory instability;
and
at least one processor for communicating with a drug infu-
sion pump controller to discontinue drug infusion 5
responsive to said determining.

9. The monitoring system of claim 8 wherein the data
comprises data from a pulse oximeter or an exhaled CO2
measurement device, wherein the pattern qualification fea-
ture comprises a pattern detection feature capable of detect- 10
ing clustering of reciprocations of SPO2, pulse, or exhaled
CO2 due to corresponding clustering of sleep apnea events.

* * * * *

专利名称(译)	集中式医院监测系统，用于自动检测上呼吸道不稳定，预防和中止药物不良反应		
公开(公告)号	US9031793	公开(公告)日	2015-05-12
申请号	US13/603659	申请日	2012-09-05
[标]申请(专利权)人(译)	LYNN劳伦斯		
申请(专利权)人(译)	LYNN，劳伦斯A.		
当前申请(专利权)人(译)	LYNN，劳伦斯A.		
[标]发明人	LYNN LAWRENCE A LYNN ERIC N		
发明人	LYNN, LAWRENCE A. LYNN, ERIC N.		
IPC分类号	G01N33/48 A61B5/00 G06F19/00		
CPC分类号	A61B5/412 A61B5/4818 A61B5/002 G06F19/3468 G16H20/17 G16H40/67		
审查员(译)	LIN，杰里		
优先权	60/291691 2001-05-17 US 60/291687 2001-05-17 US 60/295484 2001-06-01 US		
其他公开文献	US20120330118A1		
外部链接	Espacenet USPTO		

摘要(译)

一种用于在集中式医院重症监护系统中自动诊断阻塞性睡眠呼吸暂停的系统和方法，用于通过遥测监测重症监护，降压和心脏病房中的至少一个中的多个患者。该系统包括具有显示器的中央处理器，以及用于与患者一起安装的多个遥测单元，每个遥测单元具有多个用于与每个患者连接的传感器，遥测单元能够传输来自在一个优选实施例中，该方法包括对系统进行编程以分析信号并自动识别阻塞性睡眠呼吸暂停的存在和严重性并提供识别指示的步骤的传感器到中央处理器的传感器。

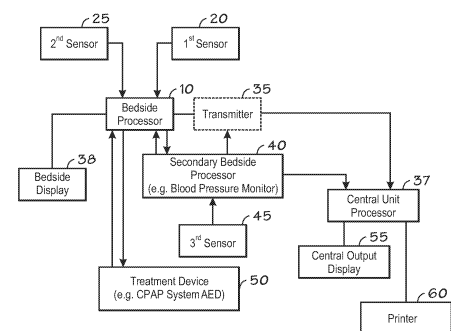

FIG. 1