



US 20070161912A1

(19) **United States**

(12) **Patent Application Publication**
Zhang et al.

(10) **Pub. No.: US 2007/0161912 A1**

(43) **Pub. Date: Jul. 12, 2007**

(54) **ASSESSING AUTONOMIC ACTIVITY USING BAROREFLEX ANALYSIS**

Publication Classification

(76) Inventors: **Yunlong Zhang**, Mounds View, MN (US); **Mark Schwartz**, White Bear Lake, MN (US)

(51) **Int. Cl.**
A61B 5/02 (2006.01)
A61B 5/00 (2006.01)
A61B 5/103 (2006.01)
(52) **U.S. Cl.** **600/483; 600/301; 600/595; 600/485; 600/500; 600/486**

Correspondence Address:
HOLLINGSWORTH & FUNK, LLC
Suite 125
8009 34th Avenue South
Minneapolis, MN 55425 (US)

(57) **ABSTRACT**

A method involves implantably detecting changes in posture of a patient's body. Baroreflex responses to the posture changes are determined. An autonomic tone of the patient is determined based on the baroreflex responses. Based on the autonomic tone, various patient susceptibilities to disease may be determined, including susceptibilities to heart disease, arrhythmia, and/or sudden cardiac death.

(21) Appl. No.: **11/329,346**

(22) Filed: **Jan. 10, 2006**

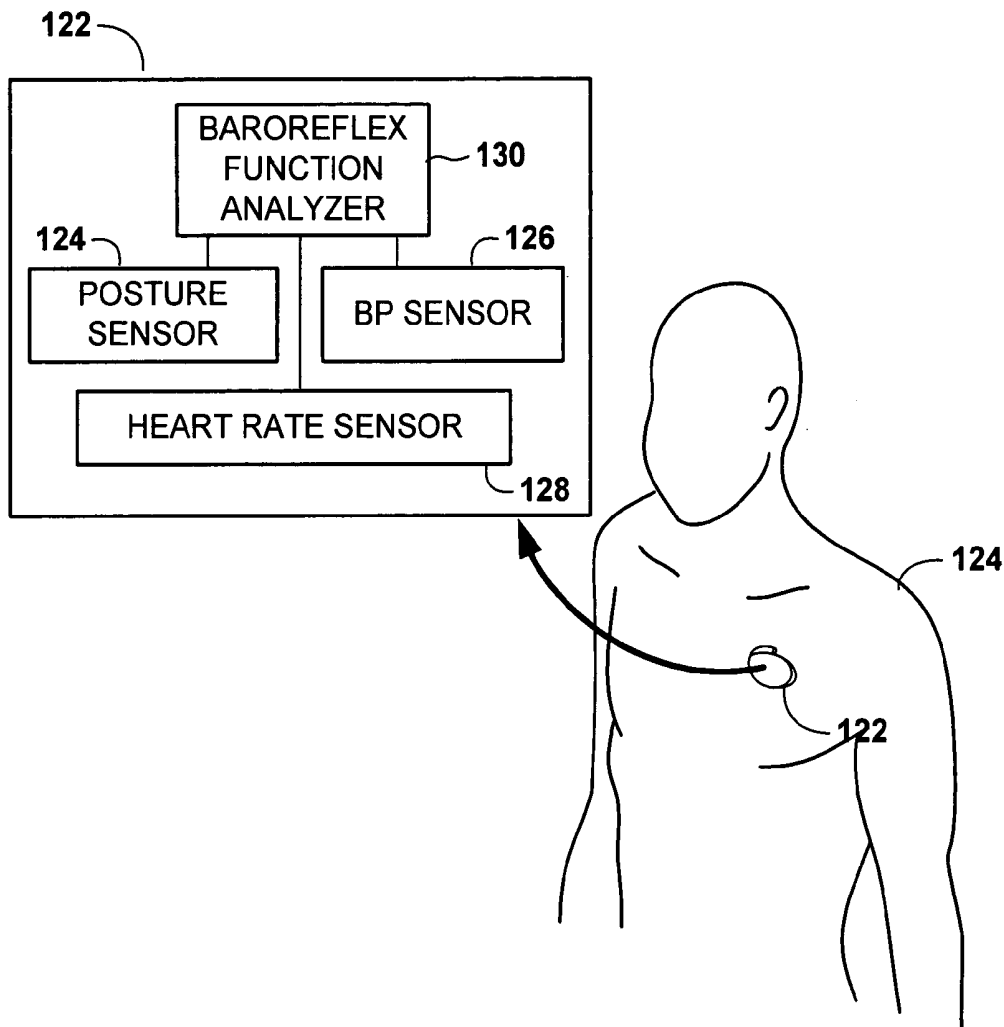

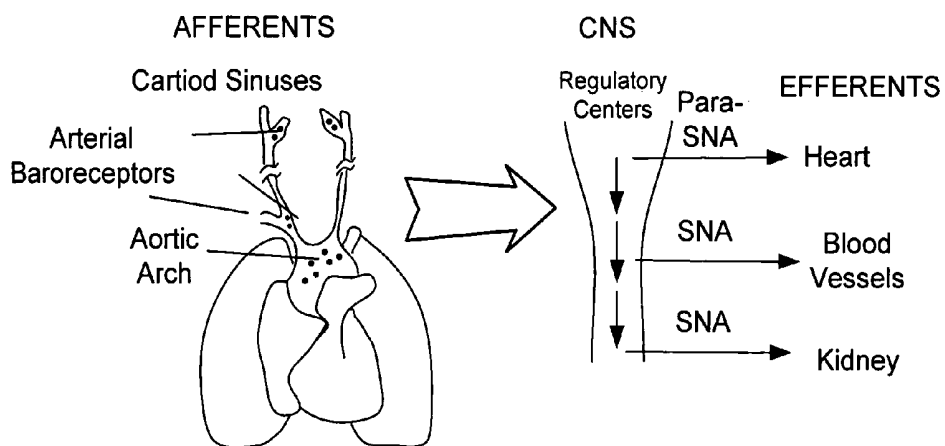

Figure 1A

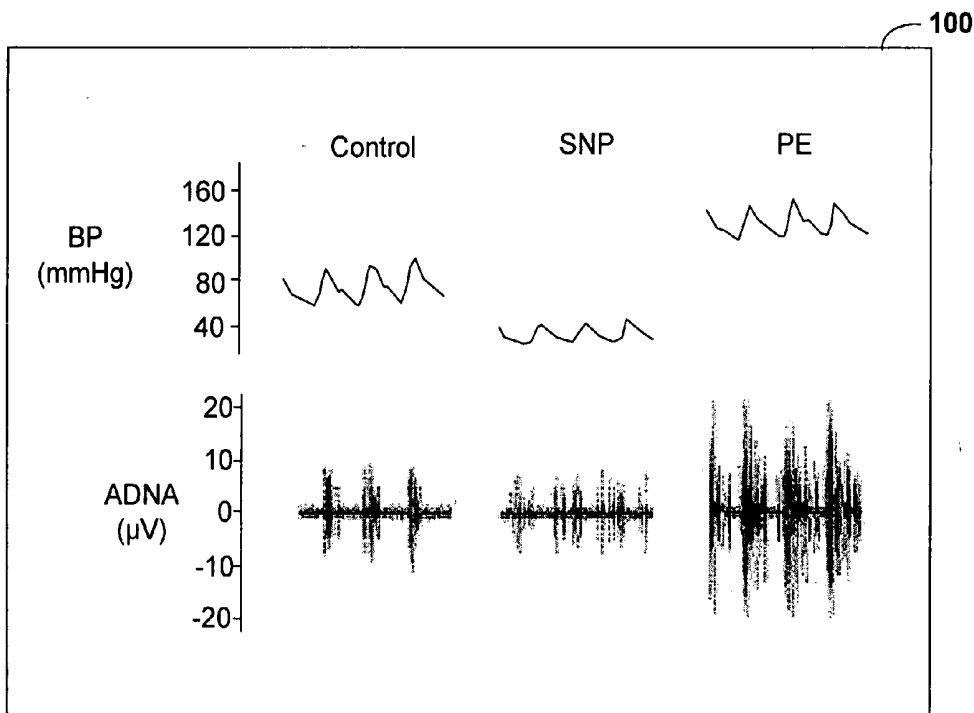

Figure 1B

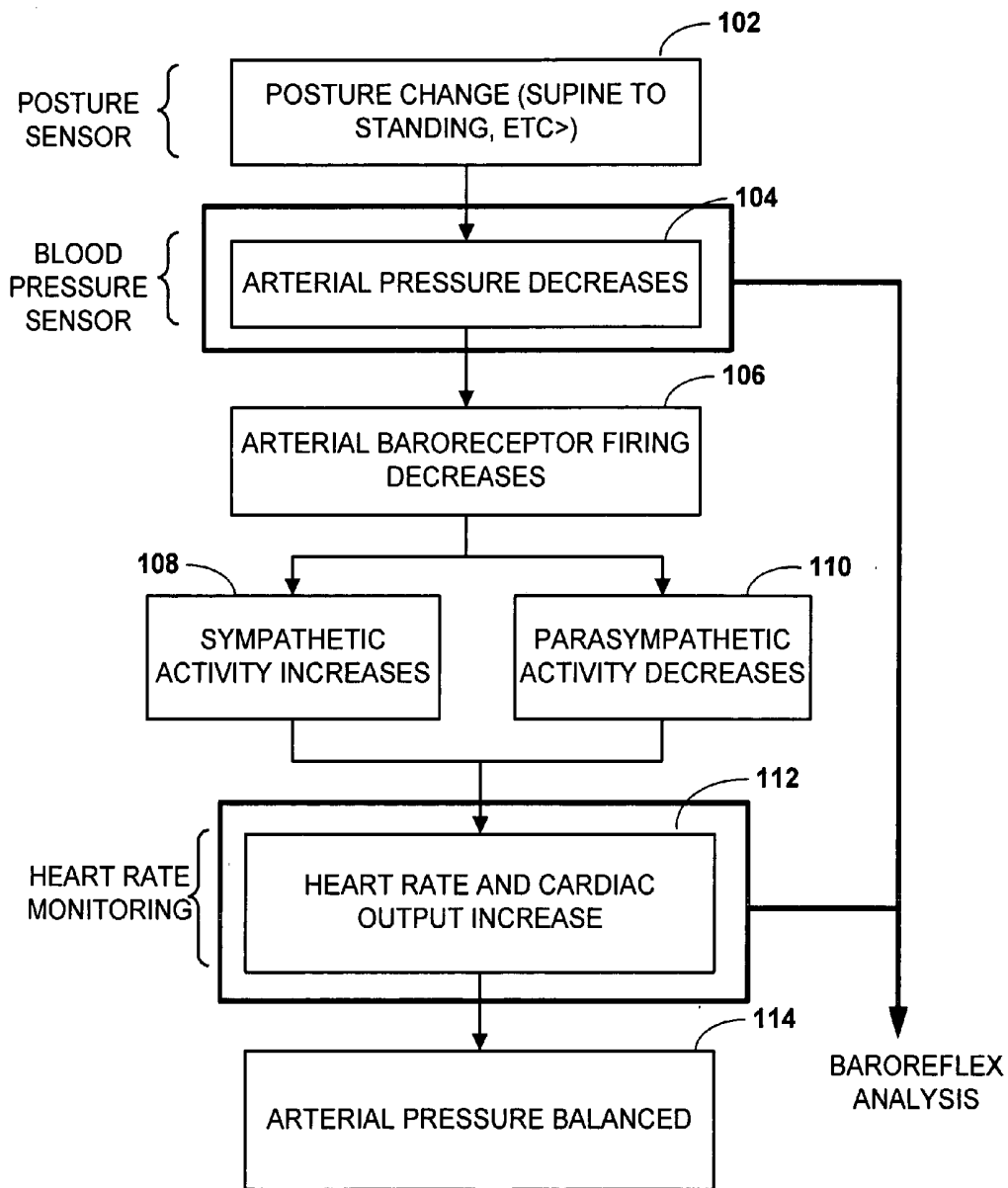

Figure 1C

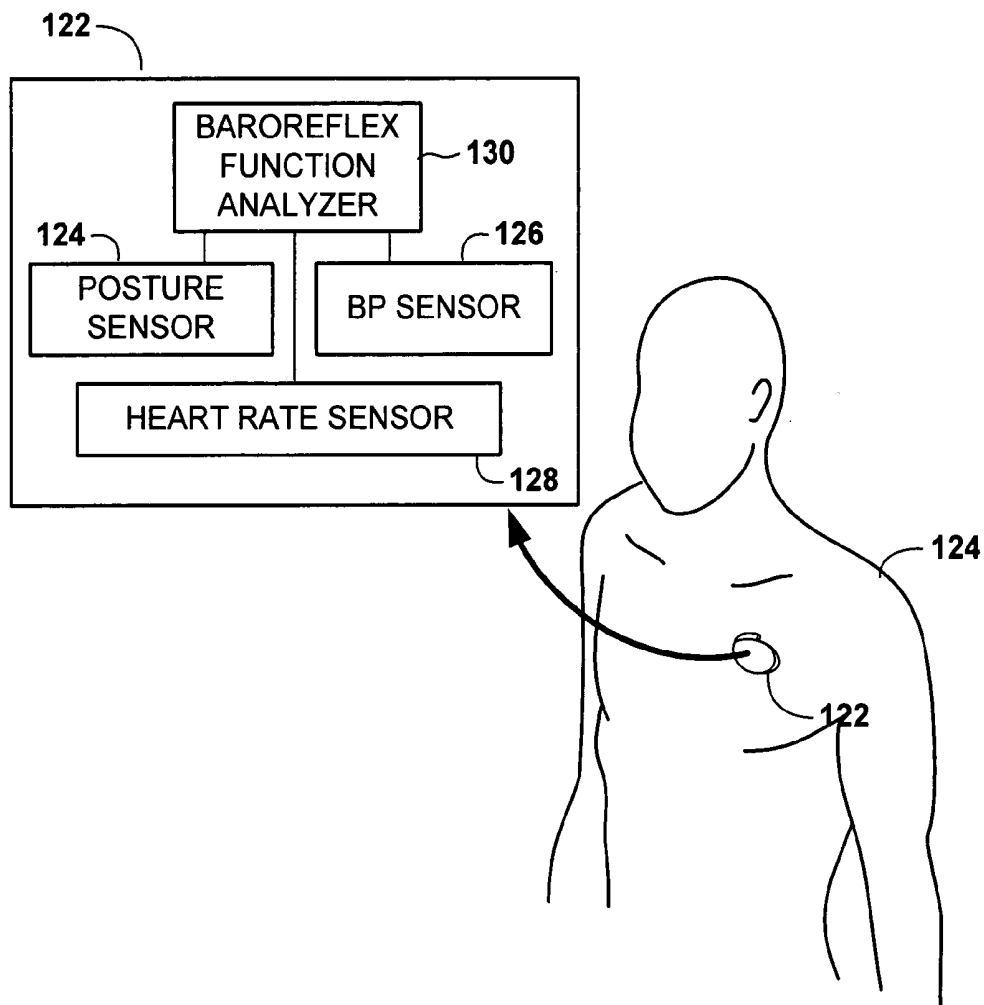

Figure 1D

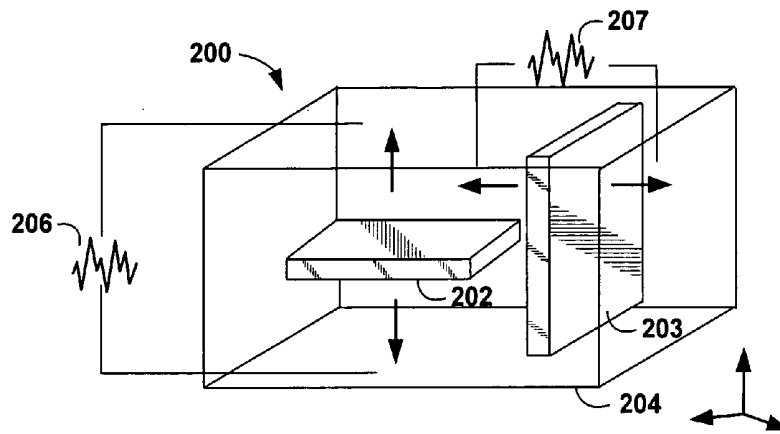

Figure 2A

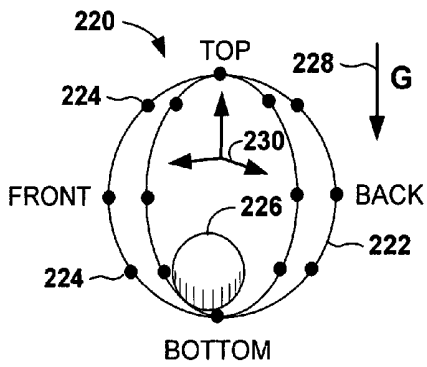

Figure 2B

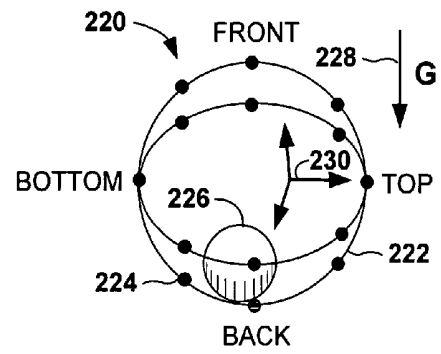

Figure 2C

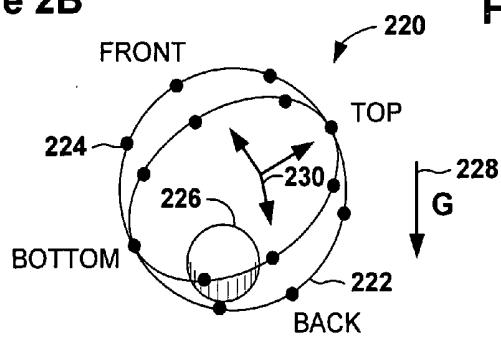

Figure 2D

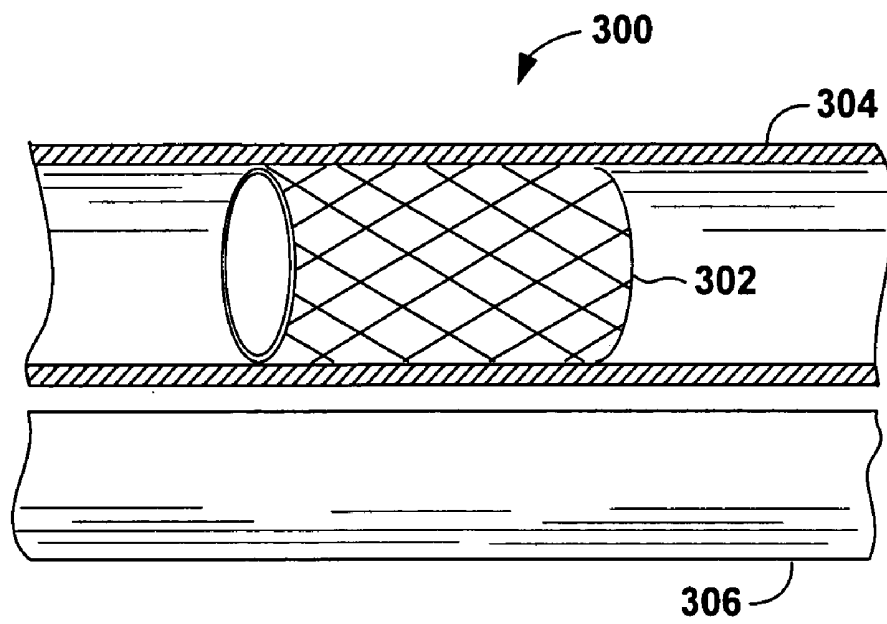

Figure 3A

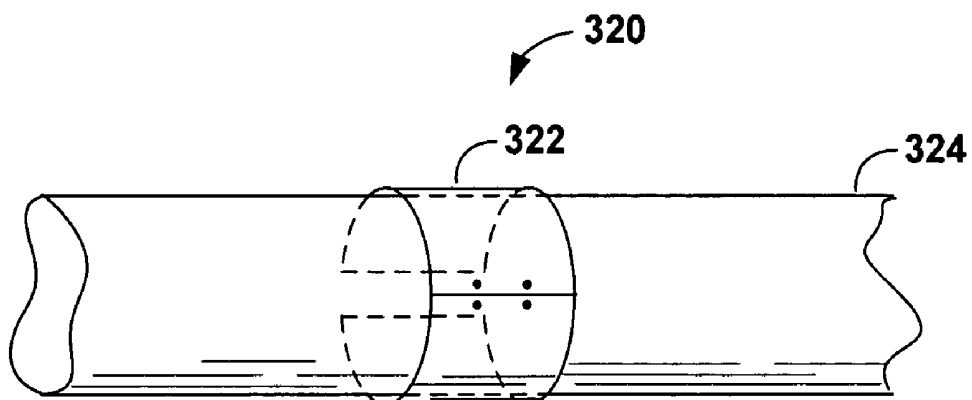

Figure 3B

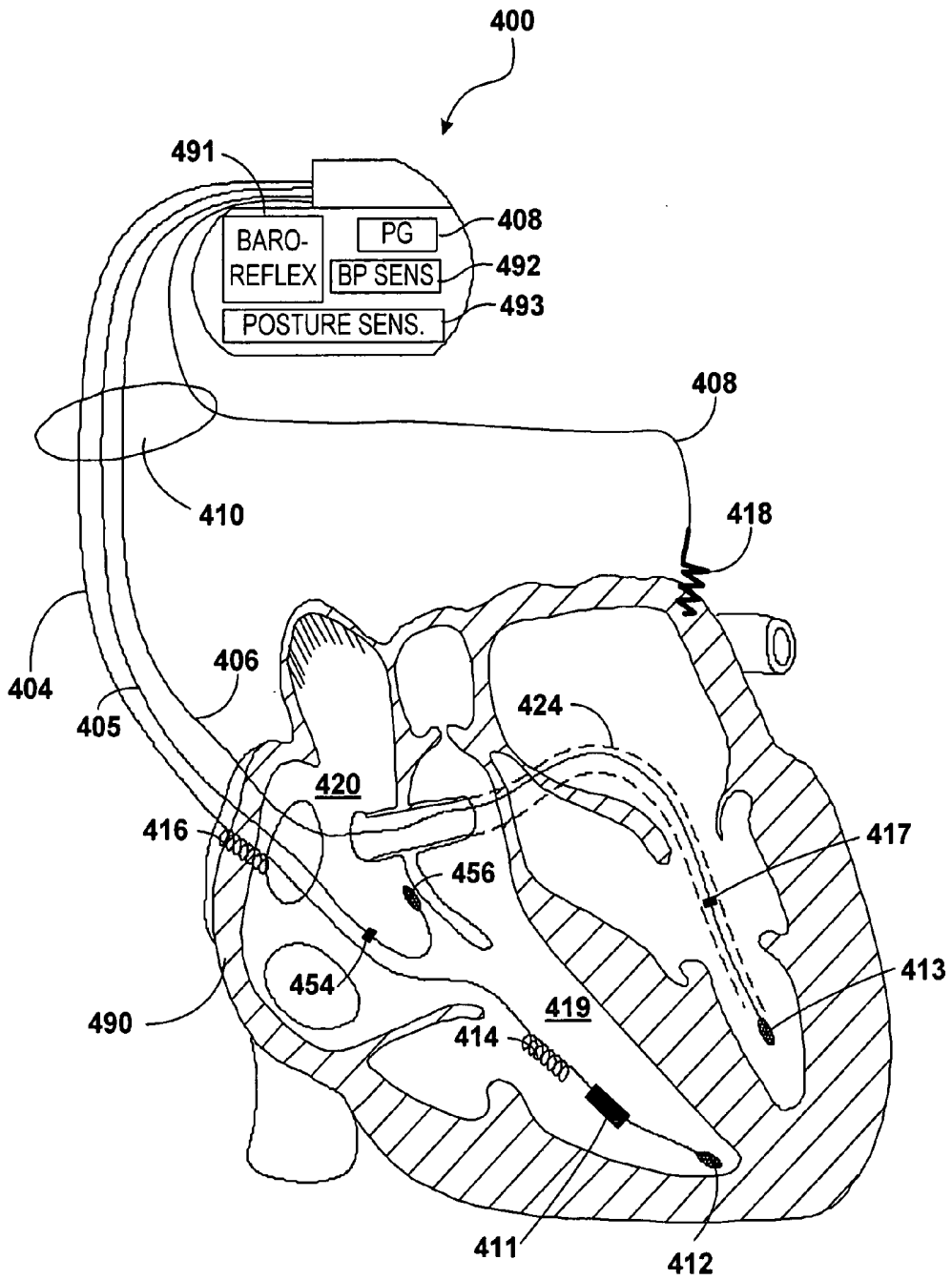

Figure 4

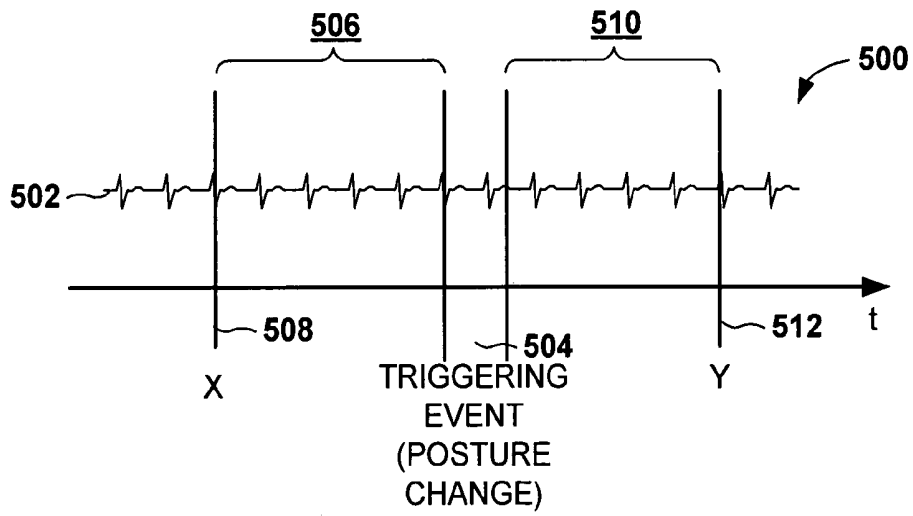

Figure 5A

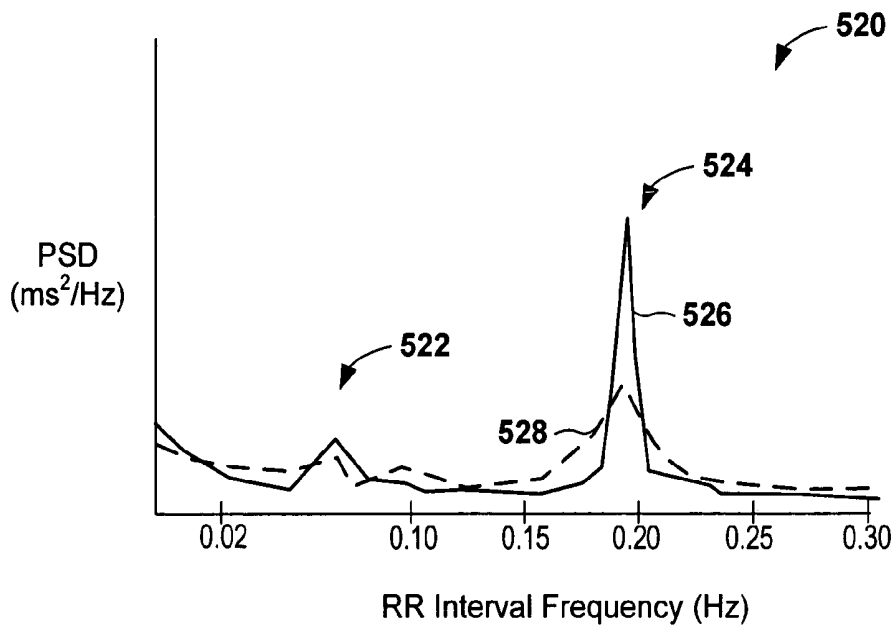

Figure 5B

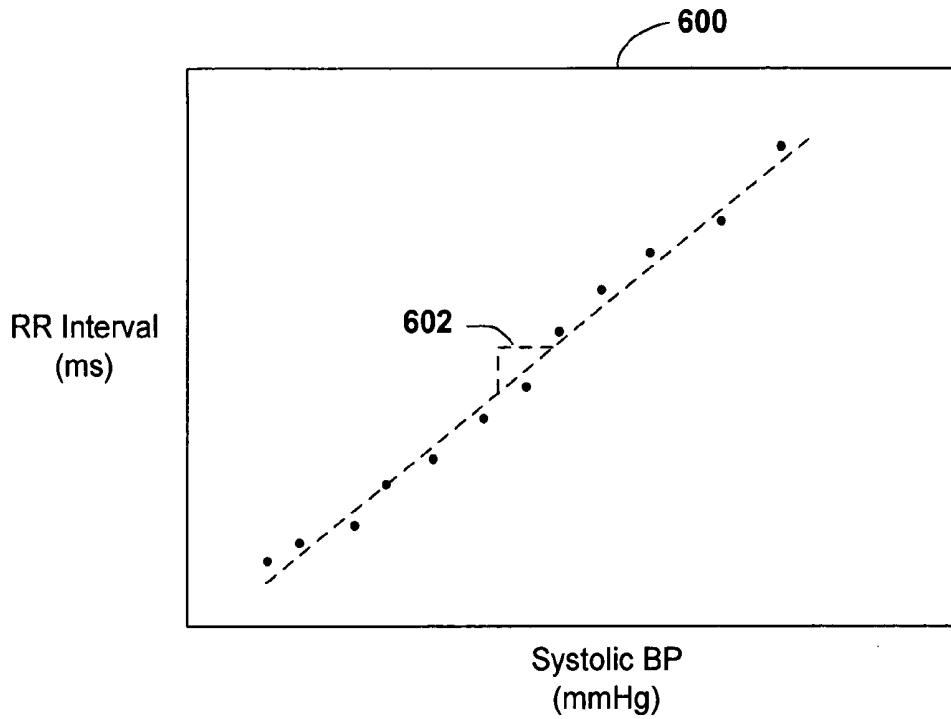

Figure 6A

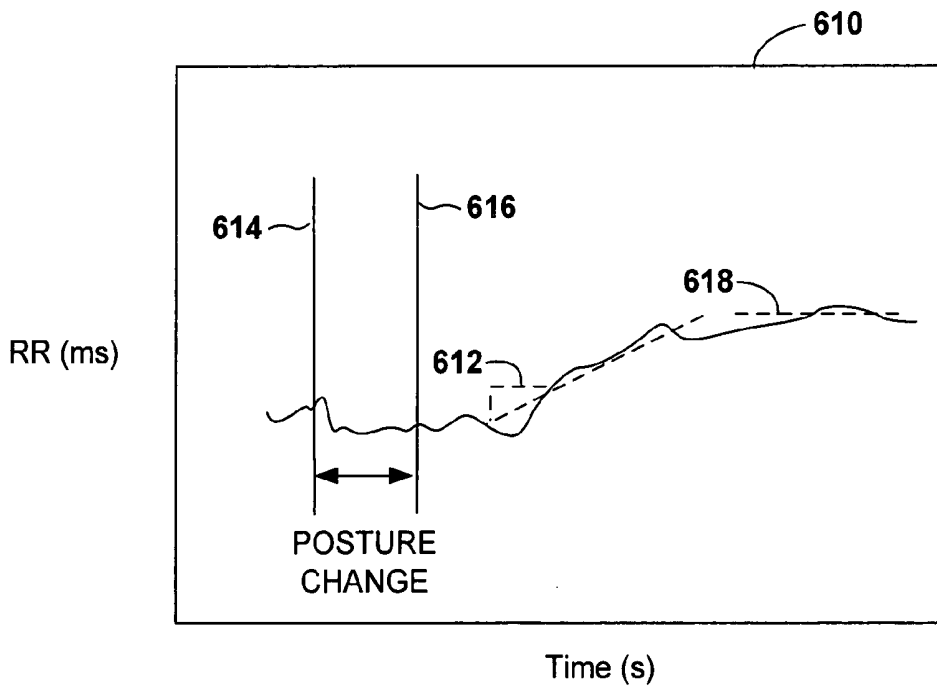

Figure 6B

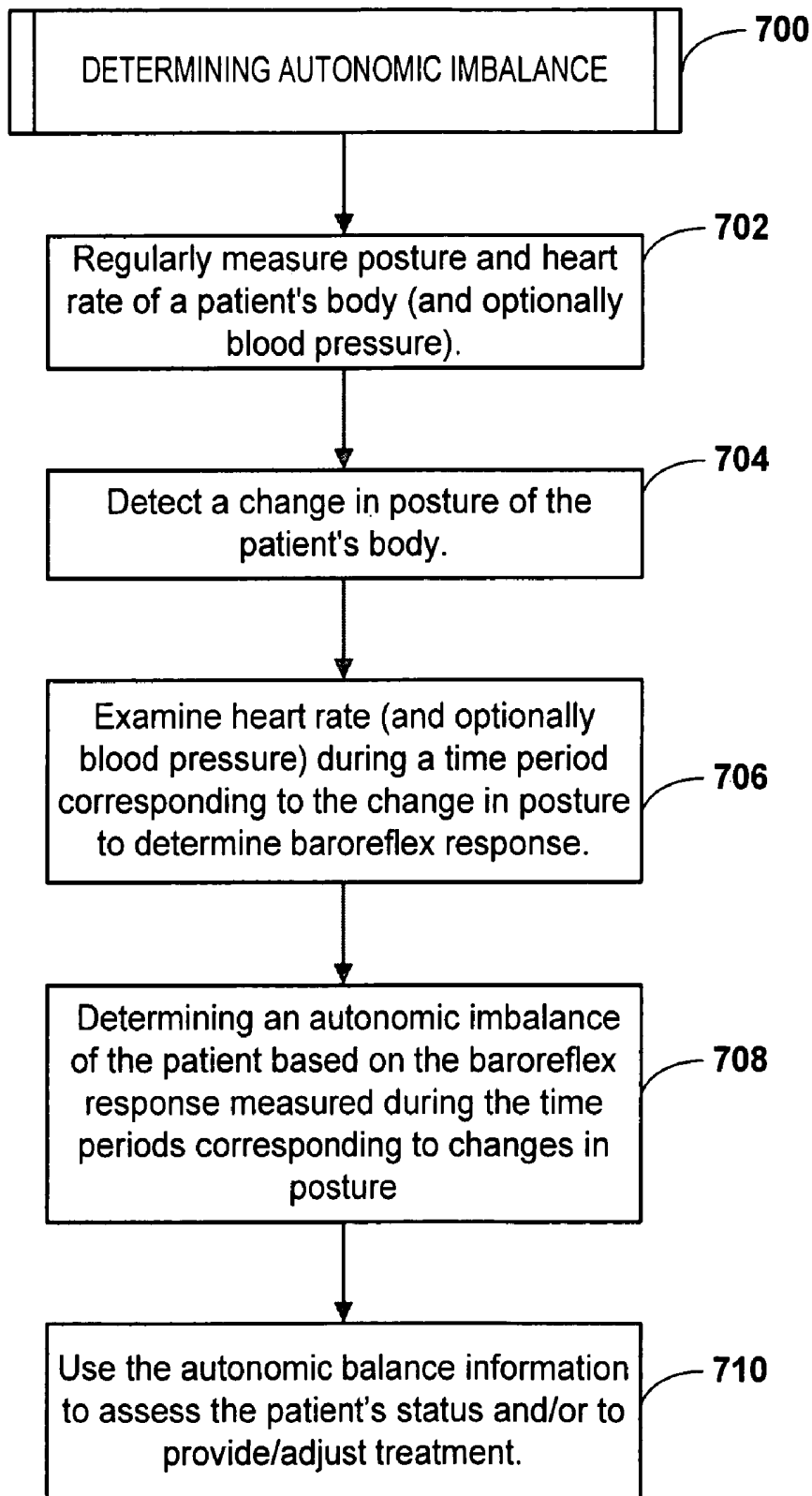

Figure 7

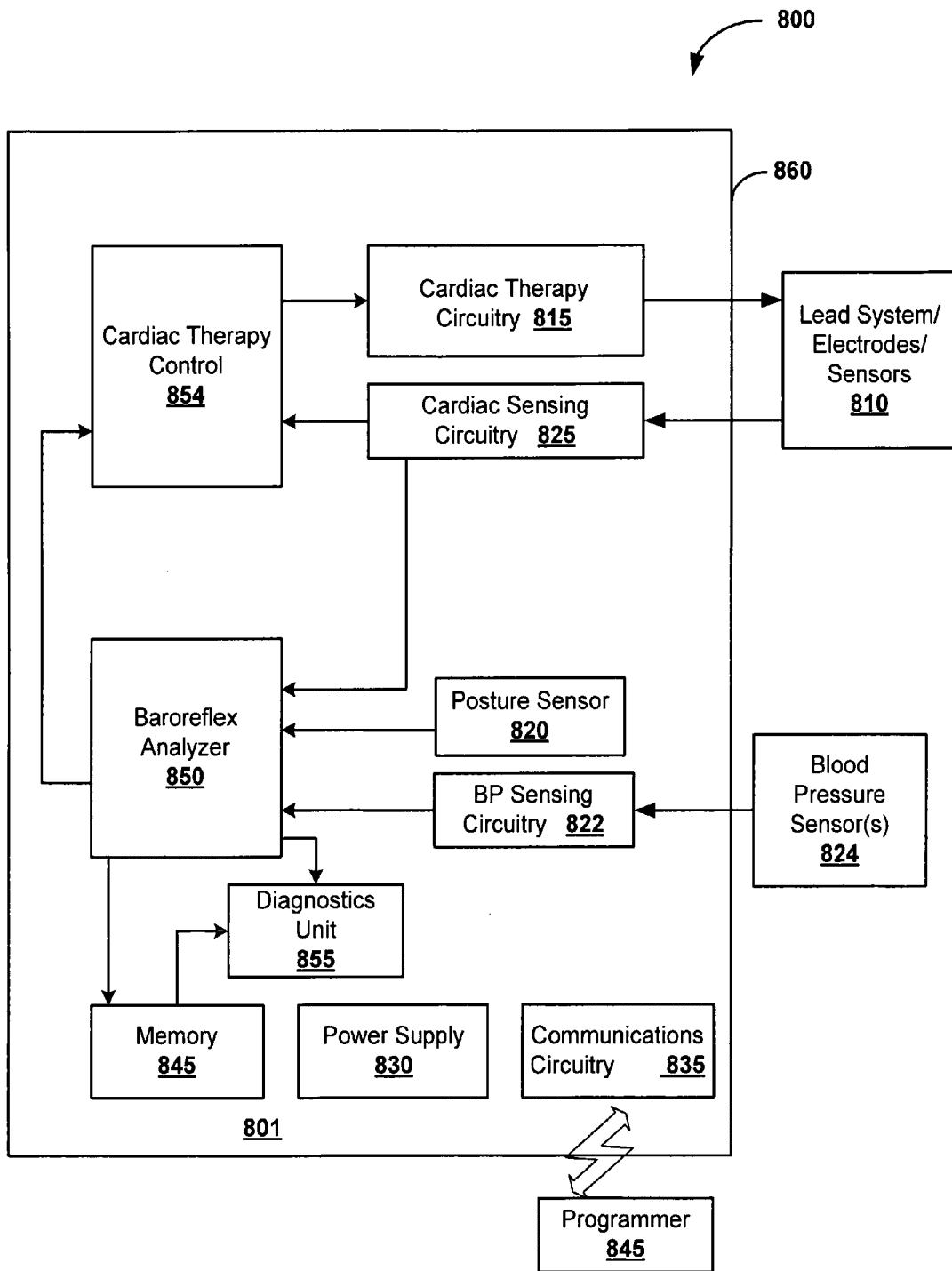

Figure 8

ASSESSING AUTONOMIC ACTIVITY USING BAROREFLEX ANALYSIS

FIELD OF THE INVENTION

[0001] The present invention relates generally to medical devices, and more particularly to detecting autonomic activities with implantable medical devices.

BACKGROUND OF THE INVENTION

[0002] Heart failure is a common public health problem, affecting over 5 million people in the U.S. alone. The annual mortality rate due to heart failure is estimated to be 20-25%. Heart failure is a costly disease, both financially and in loss of life. Recent improvements in the surgical and medical management of heart disease have made it more important that heart disease patients are early and accurately classified into high and low risk groups. By examining indicators that are more indicative of mortality risk, high risk patients can receive more targeted treatment. One set independent mortality indicators for heart failure patients are imbalances in the autonomic nervous system.

[0003] The autonomic nervous system is responsible for maintaining a relatively constant internal physiological environment by controlling such involuntary functions as digestion, respiration, perspiration, and metabolism, and by modulating blood pressure. The autonomic nervous system is divided into two subsystems, the sympathetic and the parasympathetic. The sympathetic subsystem is responsible for providing responses and energy needed to cope with stressful situations. In response to such stress, the sympathetic system increases the level of certain autonomic activity including heart rate and blood pressure. The parasympathetic nervous system, in contrast, conserves energy by, for example, slowing the heart rate and increasing intestinal and gland activity. The parasympathetic nervous system acts to reverse the effects of the sympathetic nervous system.

[0004] Increased sympathetic and depressed parasympathetic nervous activity is common in heart failure. Autonomic imbalance is suspected of predisposing the heart to chronic ventricular dysfunction. This imbalance may be characterized a marked augmentation of sympathetic drive as well as an attenuation of parasympathetic tone. This disruption of autonomic balance appears to significantly contribute to the vasoconstriction that accompanies ventricular failure. Autonomic imbalance also predisposes the heart to ventricular arrhythmias, therefore is reported to be an independent risk factor for the mortality in heart failure population.

[0005] Measuring autonomic activity may useful for many purposes. Accurately detecting and determining the level or degree of heart failure in a patient is a particularly desirable use for such measurements. The present invention describes methods, systems, and apparatuses for assessing autonomic activity. Such assessment can be used, among other things, for early identification of patients with high risk of sudden death to enable early, aggressive intervention, and offers various other advantages over the prior art.

SUMMARY OF THE INVENTION

[0006] Embodiments of the invention relate to detection of patient posture. In one embodiment of the invention, a

method involves implantably detecting changes in posture of a patient's body. Baroreflex responses to the posture changes are detected, and an autonomic tone of the patient is determined based on the baroreflex responses.

[0007] In more particular embodiments, determining baroreflex responses to the posture changes may involve measuring the patient's heart rate and/or blood pressure during time periods corresponding to the changes in posture. Measuring the blood pressure of the patient's body may involve measuring the blood pressure via a force transducer sensitive to displacement of a blood vessel, including at least one of a blood-vessel-implantable stent-like transducer and a cuff transducer placed around a blood vessel. The stent-like transducer may be implanted in a vein that is paralleled by an artery.

[0008] In other, more particular embodiments, detecting the change in posture via the implantable device involves detecting the change in posture via at least one of a piezoelectric sensor and a mechanical sensor. Determining the autonomic imbalance of the patient may involve performing a baroreflex sensitivity analysis (BSA) based on blood pressure and cardiac signals measured during a time period corresponding to the posture change. Performing the BSA may involve measuring intervals between heartbeats at least during the time period corresponding to the posture change and/or performing a power spectral analysis on the intervals between the heartbeats (e.g., R-R intervals). In other variations, performing the BSA involves determining a rate of change of between systolic blood pressure relative to the intervals during the time period corresponding to the posture change. The method may also involve determining the patient's susceptibility to heart disease, arrhythmia, and/or sudden cardiac death based on the autonomic tone.

[0009] In another embodiment of the invention, an apparatus that is capable of being implanted in a patient's body includes a posture sensor, a heart rate sensor, and a processor coupled to the posture sensor and the heart rate sensor. The processor is configured to measure the patient's heart rate via the cardiac signal sensor and detect a change in a posture of the patient's body via the posture sensor. An autonomic tone of the patient's body is determined based on the patient's heart rate measured during a time period corresponding to the change in posture.

[0010] In one arrangement, the processor is configured to determine the autonomic tone in a time period that encompasses a first time period before the change in posture and a second time period after the change in posture. The posture sensor may include at least one of a piezoelectric sensor and an accelerometer. In another arrangement, the posture sensor includes a case having a plurality of conductive surfaces disposed on an inner surface of the case and a conductive solid movably disposed along the inner surface of the case. Movement of the conductive solid within the case causes the conductive solid to create an electrical connection between at least two surfaces of the plurality of surfaces.

[0011] In another embodiment of the invention, a posture sensing system includes: means for detecting a change in posture of a patient's body; means for measuring the patient's heart rate during at least one of a first time period before the change in posture, a second time period during the change in posture, and a third time period after the change in posture; and means for determining an autonomic tone of

the patient based on the heart rate measured during the at least one of the first, second, and third time periods.

[0012] The above summary of the invention is not intended to describe each embodiment or every implementation of the invention. Advantages and attainments, together with a more complete understanding of the invention, will become apparent and appreciated by referring to the following detailed description and claims taken in conjunction with the accompanying drawings.

BRIEF DESCRIPTION OF THE DRAWINGS

[0013] FIG. 1A illustrates afferent and efferent nerve systems that may be used in connection with baroreflex analysis in accordance with embodiments of the invention;

[0014] FIG. 1B is a plot illustrating changes in aortic depressor nerve activity changes in arterial pressure that may be used in connection with baroreflex analysis in accordance with embodiments of the invention;

[0015] FIG. 1C is a block diagram illustrating the detection of baroreflex activity based on posture change according to an embodiment of the invention;

[0016] FIG. 1D illustrates an implantable device according to an embodiment of the invention;

[0017] FIG. 2A is a perspective view illustrating a posture sensing element according to an embodiment of the invention;

[0018] FIGS. 2B-D are perspective views illustrating a mechanical posture sensor according to an embodiment of the invention;

[0019] FIG. 3A is a side view illustrating a stent-like blood pressure sensing element according to an embodiment of the invention;

[0020] FIG. 3B is a side view illustrating a cuff transducer blood pressure sensor according to an embodiment of the invention;

[0021] FIG. 4 is a block diagram and cutaway view illustrating an implantable device and lead system according to an embodiment of the invention;

[0022] FIG. 5A is a time line diagram illustrating baroreflex sensitivity analysis (BSA) according to an embodiment of the invention;

[0023] FIG. 5B is a graph illustrating BSA using a power spectrum plot of the R-R interval according to an embodiment of the invention;

[0024] FIG. 6A is a graph illustrating BSA using blood pressure plotted versus the R-R interval according to an embodiment of the invention;

[0025] FIG. 6B is a graph illustrating BSA using the time rate of change of the R-R interval according to an embodiment of the invention;

[0026] FIG. 7 is a flowchart illustrating a procedure for determining autonomic imbalance according to an embodiment of the invention; and

[0027] FIG. 8 is a block diagram of an implantable device according to an embodiment of the invention.

[0028] While the invention is amenable to various modifications and alternative forms, specifics thereof have been shown by way of example in the drawings and will be described in detail below. It is to be understood, however, that the intention is not to limit the invention to the particular embodiments described. On the contrary, the invention is intended to cover all modifications, equivalents, and alternatives falling within the scope of the invention as defined by the appended claims.

DETAILED DESCRIPTION OF VARIOUS EMBODIMENTS

[0029] In the following description of the illustrated embodiments, references are made to the accompanying drawings which form a part hereof, and in which are shown by way of illustration, various embodiments by which the invention may be practiced. It is to be understood that other embodiments may be utilized, and structural and functional changes may be made without departing from the scope of the present invention.

[0030] The present invention deals with methods, systems, and devices used to detect imbalances of the autonomic nervous system for purposes of medical treatment. The autonomic nervous system plays a pivotal role in the maintenance of blood pressure. Imbalances of the autonomic nervous system are an independent mortality indicator for heart failure patients and other diseases. Detecting autonomic imbalance may be useful in other applications as well. For example patients with syncope (temporary loss of consciousness and posture) may benefit from an autonomic monitoring device. In another example, measurement of autonomic imbalance may be useful for therapy steering. Autonomic detection could be used in delivering ventricular tachycardia (VT) therapy if heart rhythm is hemodynamically stable, as well as for adjusting heart failure parameters a cardiac rhythm therapy (CRT) device. Therefore, there are many cases where it may be useful to characterize and detect autonomic imbalances.

[0031] The detection of autonomic imbalance involves measuring the autonomic response to blood pressure changes that occur when a patient changes posture (e.g., goes from standing to sitting, sitting to lying down, etc.). By measuring various aspects blood pressure and/or heart rate during posture changes, patients with high mortality risk due to autonomic imbalance can be identified and treated appropriately. Using implantable devices to detect autonomic imbalance indicators allows such measurements to be made unobtrusively and long term, and may increase the effectiveness of disease determination and treatment.

[0032] The baroreflex test, which measures the autonomic response to blood pressure changes, is one method to measure the autonomic activity. Activation of baroreflex is a major afferent limb of moment-to-moment blood pressure response to physiological or pathophysiological changes. Research has shown that baroreflex is reduced in heart failure and myocardial infarction patients, and is a predictor of the susceptibility to arrhythmias and sudden cardiac death in this population.

[0033] The baroreflex (also known as baroreceptor reflex) is the body's rapid response system for dealing with changes in blood pressure. Baroreflex is a reflex triggered by stimulation of a baroreceptor. A baroreceptor includes any sensor

of pressure changes, such as afferent nerves, sensory nerve endings in the wall of the atria of the heart, vena cava, aortic arch and/or carotid sinus, etc., that are sensitive to stretching. The baroreflex functions as a negative feedback system. Increased pressure stretches blood vessels, which in turn activates baroreceptors in the vessel walls. Activation of baroreceptors naturally occurs through increasing of the internal pressure and stretching of the arterial wall, causing baroreflex inhibition of sympathetic nerve activity (SNA) and a reduction in systemic arterial pressure. Reduction in blood pressure decreases peripheral vascular resistance and causes respiration to become faster and deeper.

[0034] In addition to altering heart rate, baroreflex, through its sympathetic effector branch, also affects resistance of peripheral vascular vessels (e.g., arterioles) and venous compliance. Baroreceptors in the human body detect the pressure of blood flowing through them, and can send messages to the central nervous system to increase or decrease total peripheral resistance and cardiac output. In this way, baroreflex may be responsible for a part of the low frequency component of heart rate variability.

[0035] FIG. 1A illustrates neural mechanisms that control the baroreflex phenomena described above. FIG. 1A generally illustrates afferent nerves that convey impulses toward a nerve center. The nerve center detects physiological changes related to the baroreflex. For example, a vasomotor nerve center deals with nerves that dilate and constrict blood vessels to control the size of the blood vessels. FIG. 1A also generally illustrates efferent nerves that convey impulses away from the nerve center. The efferent nerves deliver impulses used to control bodily functions.

[0036] FIG. 1B includes a graph 100 illustrating changes in aortic depressor nerve activity (ADNA) in response to sodium nitroprusside—(SNP) and phenylephrine—(PE) induced changes in arterial pressure. The ADNA activity in response to PE and SNP is typically used to analyze and diagnose baroreflex response. However, the use of SNP and PE to induce blood pressure changes is more suited for a lab environment, and would not be practical for long-term, ambulatory measurements of baroreflex response. More information related to the concepts illustrated in FIGS. 1A and 1B may be found in “Chapter 1: The Baroreceptor Reflex: Novel Methods and Mechanisms,” *Neural Mechanisms of Cardiovascular Regulation*, edited by Dun N. J., Machado B. H., and Pilowsky P. M., Kluwer Academic Publishers, 2004.

[0037] In reference now to FIG. 1C, a block diagram illustrates the ambulatory detection of baroreflex activity based on posture change according to an embodiment of the invention. Posture change 102 is a daily activity that could trigger baroreflex. Posture changes 102 (e.g., supine to standing, squat to standing, tilting, etc.) typically results in a pool of blood in the lower limbs and less blood flow to the heart, and thus arterial blood pressure decreases 104. In response, baroreceptor firing decreases 106, thus triggering an increase in sympathetic nerve activity 108 and a decrease in parasympathetic activity 110. In response to the nerve activity 108, 110, the heart rate and cardiac output increase 112, and blood pressure returns to normal 114. Therefore, a medical device capable of detecting baroreflex by way of ambulatory posture and blood pressure measurements could

provide important autonomic activity information useful for monitoring patients and subscribing and/or modifying treatments.

[0038] In order to obtain long-term, ambulatory measurements of baroreflex and related autonomic indicators, an implantable medical device can be used. FIG. 1D illustrates an implantable medical device 122 according to embodiments of the present invention. The medical device 122 incorporates a posture detector according to an embodiment of the invention. The device 122 may be implanted within a patient's body 124 in the upper left thoracic region, such as a typical placement for a cardiac pacemaker or defibrillator. The medical device 122 includes hardware and software capable of accurately measuring baroreflex. In particular, the medical device 122 may contain any combination of a posture sensor 124, a blood pressure sensor 126, and a heart rate sensor 128. The sensors 124, 126, 128 may be self contained within the medical device 122, and/or work in conjunction with an external apparatus that provides sensory inputs. For example, the heart rate sensor 126 may be coupled an electrode contained in intracardiac leads, where the electrode detects the electrical signals that the heart rate sensor 126 uses to determine heart rate.

[0039] The posture detector 124 may be contained within the medical device, and detect posture indirectly by detecting the orientation of the device 122 itself. The term posture as used herein generally refers to the orientation of the patient's torso relative to the earth's surface. In some cases, an absolute measurement of current posture may not be required to measure baroreflex. For example, it may sufficient for the posture detector 124 to sense only relative changes in posture (e.g., detecting rotation) in order determine baroreflex triggers. In other arrangements, it may be desirable for the posture detector 124 to sense absolute orientations of the body (e.g., standing, supine, etc.). Some sequences of posture orientations and changes may be more likely to trigger baroreflex indicators than others. For example, standing after being in a supine position for a long period may be more likely to trigger measurable baroreflex activity than other posture changes.

[0040] In response to posture changes detected by the posture detector 124, the blood pressure detector 126 and heart rate sensors 128, the device 122 will make continuous, beat-to-beat readings of blood pressure and cardiac electrical signals. These blood pressure and heart rate readings are analyzed by a baroreflex function analyzer 130. The baroreflex function analyzer 130 continuously monitors outputs of the posture, blood pressure, and heart rate sensors 124, 126, 128 and makes determinations of autonomic imbalance as determined by baroreflex indicators.

[0041] In reference now to FIG. 2A, an example embodiment of a sensor 200 used for posture detecting is illustrated. The sensor 200 includes a multiple-dimensional piezoelectric element 202. One or more elements 202, 203 are contained in a case 204 where the elements 202, 203 may deflect in response to motion. A deflection of the elements 202, 203 generates a voltage that is proportional to the deflection and is detected by circuitry (not shown) as electrical signals 206, 207.

[0042] The illustrated sensor 200 may be configured, for example, as a custom or off-the shelf device, such as a piezoelectric accelerometer. Alternate configurations of the

sensor **200** may include any sensor technology that is responsive to gravitational fields and/or motion. One example of a gravitational field sensor is a DC accelerometer, and an example of a motion sensor is an AC accelerometer. Generally, a DC accelerometer refers to a device that can measure static acceleration (i.e., 0 Hz events). For example, capacitive accelerometers are capable of measuring static acceleration. In contrast, AC accelerometers generally cannot measure static events; they need motion to provide an output. The output of AC accelerometers usually decrease as the change in acceleration approaches zero.

[0043] An alternative to using solid state devices such as the piezoelectric element **202** is to use mechanical devices. FIGS. 2B-D illustrate a mechanical posture sensor **220** according to an embodiment of the invention. The sensor **220** includes a wired case ball **222** with a plurality of electrodes **224** (or other conductive surfaces) spaced around an inner surface of the case **222**. A small conducting ball **226** is able to move about freely along the inner surface of the case ball **222**. The ball **226** tends to roll to the bottom of the case **222** due to the effect of gravity, represented by the gravitational vector **G 228**. The ball **226** completes a circuit between two or more electrodes **224**, and current flowing through the circuit(s) can be used as input to a circuit that determines orientation. The sensitivity and resolution of the sensor **220** is generally dependent on the number and spacing of electrodes **224**.

[0044] The sensor **220** has an internal coordinate system **230** that may be aligned with the patient's body. The sensor **220** detects posture changes by detecting which electrodes are **224** touched by the ball **226** in different orientations. Therefore, based on a predetermined orientation of the internal coordinate system **230** with the patient's body (e.g., the torso), the orientation of the patient can be determined based on current flowing through electrodes **224**.

[0045] The top, bottom, front, and back labels in FIGS. 2B-D indicate the orientation of the case ball **222** relative to the patient's body. Thus the orientation shown in FIG. 2B may correspond to a standing posture, the orientation in FIG. 2C may correspond to a supine posture, and the orientation shown in FIG. 2D may correspond to a reclining posture. Although not illustrated, the sensor **220** can also determine orientations along the lateral-medial axis of the body in order to detect postures such as lying on one's side.

[0046] It will be appreciated that the sensors **200**, **220** illustrated in FIGS. 2A-D are provided for illustration. Those familiar with the relevant arts may be able to adapt alternate technologies to detect gravitational field and/or motion in order to determine patient posture. For example, orientation may be derived using position sensing technologies, Doppler reflections, laser inferometry, and the like. Posture measurements may not only include measurements of the patient's body to a fixed reference (e.g., the earth's surface) but with reference to other body parts. For example, relative orientation of the legs to the torso may be used to differentiate sitting upright with standing.

[0047] The posture changes detected by posture sensors **200**, **220** can be used as a trigger for measuring other physiological responses in order to determine autonomic imbalance. One of these physiological responses is the measurement of blood pressure. Example sensors that may be used for measuring blood pressure according to embodi-

ments of the invention are shown in FIGS. 3A and 3B. FIG. 3A shows a transvenous sensor **300** that includes a stent-like element **302**. The stent-like element **302** is placed inside a vein **304** that is paralleled by an artery **306**. The stent transducer **302** can detect pressure changes via detecting the displacement or pulsatile movement induced by artery **306**. A different, less invasive approach to determining blood pressure is shown in FIG. 3B, where a blood pressure sensor **320** includes an arterial cuff transducer **322** that is placed around an artery **324**. The cuff transducer **322** may detect pressure based on expansion and contraction of the arterial wall.

[0048] Other physiological responses that can be measured following a posture change include electrical impulses of the heart. Referring now to FIG. 4 of the drawings, there is shown one embodiment of an implantable device **400** that may be used to measure cardiac electrical signals according to embodiments of the present invention. The implantable device **400** illustrated in FIG. 4 may include a baroreflex function analyzer **491**, a blood pressure sensor **492**, and a posture sensor **493** disposed within the can of the implantable device **400**. The implantable device **400** may also include a cardiac pulse generator (PG) **408** that is electrically and physically coupled to a lead system **410**.

[0049] The housing and/or header of the implantable device **400** may incorporate one or more electrodes used to provide electrical stimulation energy to the heart and to sense cardiac electrical activity. The electrodes may also be configured to detect electrical signals of the heart for purposes of detecting baroreflex indicators via the function analyzer **491**. All or a portion of the implantable device housing may be configured as a can electrode. The implantable device **400** may include an indifferent electrode positioned, for example, on the header or the housing of the implantable device **400**.

[0050] The lead system **410** is used to detect electrical signals produced by the heart **490** and may provide electrical energy to the heart **490** under certain predetermined conditions, such as to treat cardiac arrhythmias. The lead system **410** may include one or more electrodes used for pacing, sensing, and/or cardioversion/defibrillation. In the embodiment shown in FIG. 4, the lead system **410** includes an intracardiac right ventricular (RV) lead system **404**, an intracardiac right atrial (RA) lead system **405**, an intracardiac left ventricular (LV) lead system **406**, and an extracardiac left atrial (LA) lead system **408**. The lead system **410** of FIG. 4 illustrates one embodiment that may be used in connection with the multi level tachyarrhythmia therapy methodologies described herein. Other leads and/or electrodes may additionally or alternatively be used.

[0051] The lead system **410** may include intracardiac leads **404**, **405**, **406** implanted in a human body with portions of the intracardiac leads **404**, **405**, **406** inserted into a heart **490**. The intracardiac leads **404**, **405**, **406** include various electrodes positionable within the heart for sensing electrical activity of the heart and for delivering electrical stimulation energy to the heart, for example, pacing pulses and/or defibrillation shocks to treat various arrhythmias of the heart.

[0052] As illustrated in FIG. 4, the lead system **410** may include one or more extracardiac leads **408** having electrodes, e.g., epicardial electrodes, positioned at locations

outside the heart for sensing and/or pacing one or more heart chambers. The right ventricular lead system **404** illustrated in FIG. **6** includes an SVC-coil **416**, an RV-coil **414**, an RV-ring electrode **411**, and an RV-tip electrode **412**. The right ventricular lead system **404** extends through the right atrium **420** and into the right ventricle **419**. In particular, the RV-tip electrode **412**, RV-ring electrode **411**, and RV-coil electrode **414** are positioned at appropriate locations within the right ventricle for sensing and delivering electrical stimulation pulses to the heart. The SVC-coil **416** is positioned at an appropriate location within the right atrium chamber of the heart **490** or a major vein leading to the right atrial chamber of the heart **490**.

[**0053**] In one configuration, the RV-tip electrode **412** referenced to the can electrode may be used to implement unipolar pacing and/or sensing in the right ventricle **419**. Bipolar pacing and/or sensing in the right ventricle may be implemented using the RV-tip **412** and RV-ring **411** electrodes. The RV-ring **411** electrode may optionally be omitted, and bipolar pacing and/or sensing may be accomplished using the RV-tip electrode **412** and the RV-coil **414**, for example. Sensing in the RV may involve the tip-to-ring vector and the RV-coil to SVC-coil or the RV-coil to SVC coil electrically tied to the can vector. The right ventricular lead system **404** may be configured as an integrated bipolar pace/shock lead. The RV-coil **414** and the SVC-coil **416** are defibrillation electrodes.

[**0054**] The left ventricular lead **406** includes an LV distal electrode **413** and an LV proximal electrode **417** located at appropriate locations in or about the left ventricle for pacing and/or sensing the left ventricle. The left ventricular lead **406** may be guided into the right atrium **420** of the heart via the superior vena cava. From the right atrium **420**, the left ventricular lead **406** may be deployed into the coronary sinus ostium, the opening of the coronary sinus. The lead **406** may be guided through the coronary sinus to a coronary vein **424** of the left ventricle. This vein is used as an access pathway for leads to reach the surfaces of the left ventricle that are not directly accessible from the right side of the heart. Lead placement for the left ventricular lead **406** may be achieved via subclavian vein access and a preformed guiding catheter for insertion of the LV electrodes **413**, **417** adjacent to the left ventricle.

[**0055**] Unipolar pacing and/or sensing in the left ventricle may be implemented, for example, using the LV distal electrode **413** referenced to the can electrode. The LV distal electrode **413** and the LV proximal electrode **417** may be used together as bipolar sense and/or pace electrodes for the left ventricle. The left ventricular lead **406** and the right ventricular lead **404**, in conjunction with the PG **408**, may be used to provide cardiac resynchronization therapy such that the ventricles of the heart are paced substantially simultaneously, or in phased sequence, to provide enhanced cardiac pumping efficiency for patients suffering from chronic heart failure.

[**0056**] The right atrial lead **405** includes a RA-tip electrode **456** and an RA-ring electrode **454** positioned at appropriate locations in the right atrium for sensing and pacing the right atrium. In one configuration, the RA-tip **456** referenced to the can electrode, for example, may be used to provide unipolar pacing and/or sensing in the right atrium

420. In another configuration, the RA-tip electrode **456** and the RA-ring electrode **454** may be used to achieve bipolar pacing and/or sensing.

[**0057**] FIG. **4** also illustrates one embodiment of a left atrial lead system **408**. In this example, the left atrial lead **408** is implemented as an extracardiac lead with an LA distal electrode **418** positioned at an appropriate location outside the heart **490** for sensing and pacing the left atrium. Unipolar pacing and/or sensing of the left atrium may be accomplished, for example, using the LA distal electrode **418** to the can pacing vector. The left atrial lead **408** may be provided with additional electrodes used to implement bipolar pacing and/or sensing of the left atrium.

[**0058**] The cardiac signals detected from any of the leads **404**, **405**, **406**, and **408** may be used as inputs to the baroreflex function analyzer **491**. In an atrial and ventricular sensed arrangement, either atrial or ventricular signals can be used for heart rate changes for purposes of baroreflex sensitivity analysis. In a ventricular pacing arrangement where only atrial signals are sensed, atrial signals can be used for detecting heart rate changes.

[**0059**] In reference now to FIG. **5A**, a graph **500** illustrates a data capture scheme for measuring baroreflex according to an embodiment of the invention. A series of signals **502** are continuously monitored via any combination of blood pressure sensors and cardiac signal sensors. A set of data representing the signals **502** is stored in a memory buffer or some other persistent or non-persistent data storage. A triggering event **504**, here defined as a predefined change in posture, causes a baroreflex analysis to be performed. The triggering event **504** can be modeled as an instantaneous event, or as shown, as an event occurring over a finite period of time. The triggering event **504** causes the retrieval of a first set of data **506** that begins a time **X 508** preceding the triggering event **504**. In order to record data that precedes an unpredictable event, the relevant data that forms the data set **506** could be continuously captured (e.g., placed in a circular buffer), and when the triggering event **504** is detected, the data set **506** moved from the continuous buffer to a secondary memory buffer for purposes of performing calculations. The data set **506** (or other captured data) may also be moved to a persistent data storage for purposes such as building patient baseline data for physician view/retrieval and setting thresholds for a diagnostic alarm.

[**0060**] The signals **502** are also recorded after the trigger event **504** to determine a second set of data **510** that represents the state of the signals **502** after the trigger event **504** up until a time **Y 512** after the event **504**. The two sets of data **506**, **510** can then be used to perform a baroreflex sensitivity analysis (BSA) to determine autonomic imbalance. The data occurring within the event **504** (assuming it is modeled as having non-zero duration) may also be used for the calculations. The times **X 508** and **Y 512** may be defined based on empirical analysis, and may be limited by such factors as available memory and processing speed of the measuring device. In one embodiment, the time **X 508** may be about two minutes before the triggering event **504** and the time **Y 512** may be about three minutes after the triggering event **504**.

[**0061**] After the data **506**, **510** is gathered according to a scheme such as described in relation to FIG. **5A**, it can be processed in a number of ways to determine various aspects

of the baroreflex response. In reference now to FIG. 5B, a power spectrum plot 520 is shown illustrating heart rate variation according to an embodiment of the invention. The illustrated spectrum plot 520 contains may contain a number of components/features that can be used to characterize baroreflex. For example, a low frequency component 522 around 0.05 Hz may be regulated by vagus and cardiac sympathetic nerves. A high frequency component 524 around 0.20 Hz may be synonymous with respiration. The total power of the signal, integrated over all frequencies, is equal to the variance of the entire signal. The shape of the power spectrum 520 and/or discrete variables such as variance may be used to perform a baroreflex sensitivity analysis. For example, spectrum 528 has a flatter response around the characteristic frequencies 522, 524 compared to a spectrum 526 of a normal patient. Thus the spectrum 528 may be indicative of autonomic imbalance.

[0062] In reference now to FIG. 6A, another graph 600 illustrates a standard calculation of baroreflex sensitivity analysis using systolic blood pressure and the R-R interval according to an embodiment of the invention. The relationship between systolic blood pressure and is plotted against the subsequent R-R interval during the period over which posture change is detected. The slope 602 of this relationship is calculated and used to analyze baroreflex sensitivity. Although FIG. 6A uses R-R interval for baroreflex sensitivity analysis, it will be appreciated that any appropriate heart rate interval may be used (e.g., A-A interval).

[0063] Although the method of determining baroreflex shown in FIG. 6A is effective, other methods may be more amenable to measurement via implantable devices. One novel approach for determining baroreflex sensitivity according to an embodiment of the invention is shown in the graph 610 of FIG. 6B. In this graph 610, the patient's R-R interval is plotted as a function of time. Posture change is a trigger of the baroreflex. The baroreflex sensitivity is determined as the slope 612 of this plot in a time period roughly corresponding to change in posture.

[0064] The change in posture is represented in FIG. 6B by time values 614 and 616. The blood pressure and heart rate changes occur at a time beyond the posture change itself 614, 616. Typically, the posture change 614, 616 takes 1 or 2 seconds, and blood pressure decrease starts after the posture change (e.g., after time 616). The baroreflex analysis will generally monitor blood pressure and heart rate for some period of time after the posture change 614, 616 is complete. For example, measurements may be taken until a plateau 618 is measured. Thereafter, the data captured preceding the plateau 618 and after (or near) the completion of posture change 616 can be used to calculate the slope 612 to determine baroreflex sensitivity.

[0065] In reference now to FIG. 7, a procedure 700 is illustrated for determining an autonomic disorder according to an embodiment of the present invention. The procedure 700 involves regularly measuring 702 posture heart rate (e.g. cardiac signals) of a patient's body. These measurements 702 may also include blood pressure, and are typically made via an integrated, implantable device, although other devices may also be used for some or all of the measurements. During the measurement 702, a change in posture is detected 704 in the patient's body, typically involving a change in orientation of the torso.

[0066] When the change is detected 704, a baroreflex response is determined 706 based on data captured during a time period corresponding to the change in posture 704. The time period may encompass readings made before the posture change 704 and/or after the posture change 704. This determination 706 may include a baroreflex sensitivity analysis (BSA), and use any combination of techniques, including R-R spectral analysis, rate of change of between systolic blood pressure relative to R-R intervals, and time rate of change of R-R intervals during the change in posture 704. Any baroreflex responses so determined 706 may be used to determine 708 autonomic imbalances. The autonomic imbalances detected 708 may then be used 710 to assess patient status and to provide for or adjust treatment.

[0067] Referring now to FIG. 8, there is shown a block diagram of an implantable device 800 suitable for implementing baroreflex sensitivity and autonomic imbalance determinations according to an embodiment of the present invention. FIG. 8 shows the implantable device 800 divided into functional blocks. There exist many possible configurations in which these functional blocks can be arranged. The example depicted in FIG. 8 is one possible functional arrangement. The implantable device 800 depicted in FIG. 8 includes CRM circuitry including cardiac sensing circuitry for receiving cardiac signals from a heart and delivering electrical energy in the form of pace pulses or cardioversion/defibrillation pulses to the heart.

[0068] The housing 860 of the implantable device 800 encloses a single- or multi-axis posture sensor assembly 820. The posture sensor 820 may include any combination of piezoelectric elements, ball and cup tilt sensors, mechanical tilt sensors, DC accelerometers, AC accelerometers, or any other posture sensor known in the art. The sensor assembly 820 may also have other internal or external signal conditioning circuitry (not shown) such as high pass and low pass filters.

[0069] The implantable device 800 also includes a blood pressure sensing assembly 822 that is coupled to blood pressure sensors 824. The blood pressure sensors 824 may include any combination of stent sensors, cuff sensors, or other blood pressure sensing technologies known in the art. The implantable device 800 also includes cardiac sensing circuitry 825 used to detect cardiac electrical signals via sensors such as implantable electrodes.

[0070] The outputs of the cardiac sensing circuitry 825, blood pressure sensing circuitry 822, and posture sensor 820, are coupled to a baroreflex analyzer 850. The baroreflex analyzer 850 may be used to determine autonomic imbalance in accordance with methodologies of the present invention described herein. For example, the baroreflex analyzer 850 may make determination of autonomic imbalance using baroreflex sensitivity analysis (BSA).

[0071] The baroreflex analyzer 850 may be implemented using general-purpose, programmable microprocessors or custom digital and/or analog circuitry. The baroreflex analyzer 850 may be able to access registers of a memory 845 for storing and retrieving data of interest, including measurements of dynamic or mean blood pressures, cardiac signal waveforms, R-R intervals, posture, etc. The baroreflex analyzer 850 may include circuitry and/or instructions for performing various functions known in the art that are applicable to the present invention. For example, the posture

processor **850** may include digital signal processing (DSP) logic for performing spectral analysis on R-R intervals measured before and after posture change trigger events.

[0072] In the embodiment illustrated in FIG. 8, the baroreflex analyzer **850**, posture sensor **820**, blood pressure sensing circuitry **822**, and calibration circuitry **840** are disposed within the housing **860** of the implantable device **800** along with CRM circuitry. A cardiac lead system **810** may be implanted so that cardiac electrodes are electrically coupled to the heart tissue as described above in connection with FIG. 4. The cardiac electrodes of the lead system **810** along with sensing circuitry **825** disposed within the implantable device housing are used to sense cardiac signals associated with electrical activity of the heart.

[0073] The cardiac electrodes and lead system **810** may also be used to deliver electrical stimulation pulses or shocks generated by the cardiac therapy circuitry **815** to the heart for treating various cardiac arrhythmias. The CRM circuitry, including the therapy control circuitry **854**, cardiac sensing circuitry **825**, cardiac therapy circuitry **815**, and cardiac electrodes/lead system **810**, may detect cardiac signals and deliver therapeutic electrical stimulation to any of the left and right ventricles and left and right atria, for example. In some implementations, the therapy control circuitry may use posture and/or BSA information to modify therapy delivered to the patient.

[0074] Power to the implantable device **860** is supplied by an electrochemical battery **830** that is housed within the implantable device **860**. The implantable device **860** may also include various forms of memory **845**. The memory **845** may be used to store sensor information for tracking changes in patient autonomic tone over time. In some implementations, the implantable device **860** may incorporate a diagnostics processor **855** that utilizes autonomic information stored in memory **840**, possibly along with other information, to detect the presence or track the progression of various medical disorders. In another implementation, the diagnostics processor is incorporated in a remote patient external device. The posture information, along with other parameters and data stored in the memory **840**, may be transmitted via telemetry to an external programmer unit **845** or other patient-external device, as desired.

[0075] Communications circuitry **835** allows the implantable device **860** to communicate with an external programmer unit **845** and/or other patient-external system(s). In one embodiment, the communications circuitry **835** and the programmer unit **845** use a wire loop antenna and a radio frequency telemetric link to receive and transmit signals and data between the programmer **845** and communications circuitry **835**. In this manner, programming commands and/or other information may be transferred to the implantable device **860** from the programmer **845** during and after implant.

[0076] A number of the examples presented herein involve block diagrams illustrating functional blocks used for in accordance with embodiments of the present invention. It will be understood by those skilled in the art that there exist many possible configurations in which these functional blocks can be arranged and implemented.

[0077] The examples depicted herein provide examples of possible functional arrangements used to implement the

approaches of the invention. The components and functionality depicted as separate or discrete blocks/elements in the figures in general can be implemented in combination with other components and functionality. The depiction of such components and functionality in individual or integral form is for purposes of clarity of explanation, and not of limitation. It is also understood that the components and functionality depicted in the Figures and described herein can be implemented in hardware, software, or a combination of hardware and software.

[0078] Methods, devices, and systems in accordance with the present invention may incorporate one or more of the features, structures, methods, or combinations thereof described herein. For example, a medical system may be implemented to include one or more of the features and/or processes described herein. It is intended that such a method, device, or system need not include all of the features and functions described herein, but may be implemented to include one or more selected features and functions that provide unique structures and/or functionality.

[0079] Various modifications and additions can be made to the embodiments discussed hereinabove without departing from the scope of the present invention. Further, although the present description is related to medical device uses, it will be appreciated that similar sensing circuitry may be used in other medical, industrial, or military applications that may require the measurement of device orientation. Accordingly, the scope of the present invention should not be limited by the particular embodiments described above, but should be defined only by the claims set forth below and equivalents thereof.

What is claimed is:

1. A method, comprising:

implantably detecting changes in posture of a patient's body;

determining baroreflex responses to the posture changes; and

determining an autonomic tone of the patient based on the baroreflex responses.

2. The method of claim 1, wherein determining baroreflex responses to the posture changes comprises measuring the patient's heart rate during time periods corresponding to the changes in posture.

3. The method of claim 2, wherein determining baroreflex responses to the posture changes further comprises measuring the patient's blood pressure during the time periods corresponding to the changes in posture.

4. The method of claim 3, wherein measuring the blood pressure of the patient's body comprises measuring the blood pressure via a force transducer sensitive to displacement of a blood vessel.

5. The method of claim 4, wherein measuring the blood pressure of the patient's body via a force transducer comprises measuring the blood pressure via at least one of a blood-vessel-implantable stent-like transducer and a cuff transducer placed around a blood vessel.

6. The method of claim 5, wherein measuring the blood pressure of the patient's body via the stent-like transducer comprises measuring the blood pressure from the stent-like transducer implanted in a vein that is paralleled by an artery.

7. The method of claim 1, further comprising forming a baseline data set from long-term measurements of posture changes and baroreflex responses.

8. The method of claim 1, further comprising forming a threshold for diagnostic alarm based on the baseline data set.

9. The method of claim 1, wherein determining the autonomic imbalance of the patient comprises performing a baroreflex sensitivity analysis (BSA) based on blood pressure and cardiac signals measured during a time period corresponding to the posture change.

10. The method of claim 9, wherein performing the BSA comprises measuring intervals between heartbeats at least during the time period corresponding to the posture change.

11. The method of claim 10, wherein performing the BSA comprises performing a power spectral analysis on the intervals between the heartbeats.

12. The method of claim 10, wherein performing the BSA comprises determining a rate of change of between systolic blood pressure relative to the intervals during the time period corresponding to the posture change.

13. The method of claim 1, further comprising determining the patient's susceptibility to heart disease based on the autonomic tone.

14. The method of claim 13, wherein determining the patient's susceptibility to heart disease comprises determining the patient's susceptibility to arrhythmia based on the autonomic tone.

15. The method of claim 13, wherein determining the patient's susceptibility to heart disease comprises determining the patient's susceptibility to sudden cardiac death based on the autonomic tone.

16. An apparatus capable of being implanted in a patient's body, comprising:

a posture sensor;

a heart rate sensor; and

a processor coupled to the posture sensor and the heart rate sensor, the processor configured to,

measure the patient's heart rate via the cardiac signal sensor;

detect a change in a posture of the patient's body via the posture sensor; and

determine an autonomic tone of the patient's body based on the patient's heart rate measured during a time period corresponding to the change in posture.

17. The apparatus of claim 16, wherein the time period encompasses a first time period before the change in posture and a second time period after the change in posture.

18. The apparatus of claim 16, further comprising a blood pressure sensor, and wherein the processor is further configured to measure the patient's blood pressure via the blood pressure sensor and determine the autonomic tone based on the blood pressure measured during the time period.

19. The apparatus of claim 18, wherein the blood pressure sensor comprises a force transducer sensitive to displacement of a blood vessel.

20. The apparatus of claim 19, wherein the force transducer comprises a stent-like element capable of being implanted within a blood vessel of the patient's body.

21. The apparatus of claim 19, wherein the force transducer comprises a cuff transducer capable of being placed around a blood vessel.

22. The apparatus of claim 18, wherein the processor is configured to determine the autonomic tone by performing a baroreflex sensitivity analysis (BSA) based on the heart rate and blood pressure measured during the time period.

23. The apparatus of claim 22, wherein performing the BSA comprises determining a rate of change of between systolic blood pressure relative to heart beat intervals during the change in posture.

24. The apparatus of claim 16, wherein the posture sensor comprises at least one of a piezoelectric sensor and an accelerometer.

25. The apparatus of claim 16, wherein the posture sensor comprises:

a case having a plurality of conductive surfaces disposed on an inner surface of the case;

a conductive solid movably disposed along the inner surface of the case, wherein movement of the conductive solid within the case causes the conductive solid to create an electrical connection between at least two surfaces of the plurality of surfaces.

26. The apparatus of claim 16, wherein the processor is configured to determine the autonomic tone by performing a baroreflex sensitivity analysis (BSA) based on the heart rate signals measured during the time period.

27. The apparatus of claim 26, wherein the processor is configured to perform the BSA based on a power spectral analysis on heart beat intervals determined via the heart rate sensor.

28. The apparatus of claim 26, wherein the processor is configured to perform the BSA based on a time rate of change of heart beat intervals during the change in posture.

29. A posture sensing system comprising:

means for detecting a change in posture of a patient's body;

means for measuring the patient's heart rate during at least one of a first time period before the change in posture, a second time period during the change in posture, and a third time period after the change in posture; and

means for determining an autonomic tone of the patient based on the heart rate measured during the at least one of the first, second, and third time periods.

30. The system of claim 29, further comprising:

means for measuring the patient's blood pressure; and

means for determining the patient's autonomic tone based on the blood pressure measured during the at least one of the first, second, and third time periods.

* * * * *

专利名称(译)	使用压力反射分析评估自主神经活动		
公开(公告)号	US20070161912A1	公开(公告)日	2007-07-12
申请号	US11/329346	申请日	2006-01-10
[标]申请(专利权)人(译)	张云龙 SCHWARTZ MARK		
申请(专利权)人(译)	张云龙 SCHWARTZ MARK		
当前申请(专利权)人(译)	张云龙 SCHWARTZ MARK		
[标]发明人	ZHANG YUNLONG SCHWARTZ MARK		
发明人	ZHANG, YUNLONG SCHWARTZ, MARK		
IPC分类号	A61B5/02 A61B5/00 A61B5/103		
CPC分类号	A61B5/0215 A61B5/024 A61B5/103 A61B2562/0219 A61B5/6862 A61B5/6869 A61B5/6876 A61B5/4035 A61B5/4047		
其他公开文献	US8109879		
外部链接	Espacenet USPTO		

摘要(译)

一种方法涉及植入地检测患者身体姿势的变化。确定压力反射对姿势变化的反应。基于压力反射反应确定患者的自主音调。基于自主神经张力，可以确定患者对疾病的各种易感性，包括对心脏病，心律失常和/或心源性猝死的易感性。

