



(19) **United States**

(12) **Patent Application Publication**
DERCHAK

(10) **Pub. No.: US 2011/0054272 A1**

(43) **Pub. Date: Mar. 3, 2011**

(54) **METHOD AND SYSTEM FOR MONITORING
PHYSIOLOGICAL AND ATHLETIC
PERFORMANCE CHARACTERISTICS OF A
SUBJECT**

(52) **U.S. Cl. 600/301; 600/391**

(75) **Inventor: P. Alexander DERCHAK, Oxnard,
CA (US)**

(57) **ABSTRACT**

(73) **Assignee: Adidas AG, World of Sports,
Herzogenaurach (DE)**

The present invention is directed to systems and methods for monitoring characteristics of a subject. A system according to an exemplary embodiment of the invention includes a sensor subsystem including at least one respiratory sensor disposed proximate to the subject and configured to detect a respiratory characteristic of the subject, wherein the sensor subsystem is configured to generate and transmit at least one respiratory signal representing the respiratory characteristic, and at least one physiological sensor disposed proximate to the subject and configured to detect a physiological characteristic of the subject, wherein the sensor subsystem is configured to generate and transmit at least one physiological signal representing the physiological characteristic, and a processor subsystem in communication with the sensor subsystem, the processor subsystem being configured to receive at least one of the at least one respiratory signal and the at least one physiological signal.

(21) **Appl. No.: 12/869,585**

(22) **Filed: Aug. 26, 2010**

Related U.S. Application Data

(60) **Provisional application No. 61/275,586, filed on Sep. 1, 2009.**

Publication Classification

(51) **Int. Cl.**
A61B 5/00 (2006.01)
A61B 5/04 (2006.01)

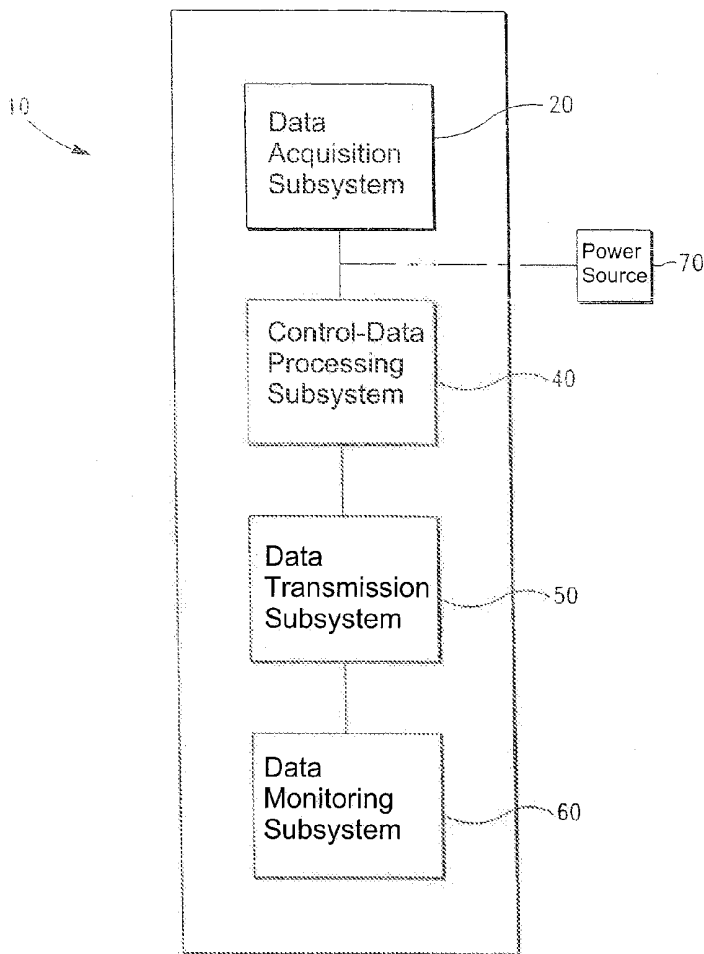

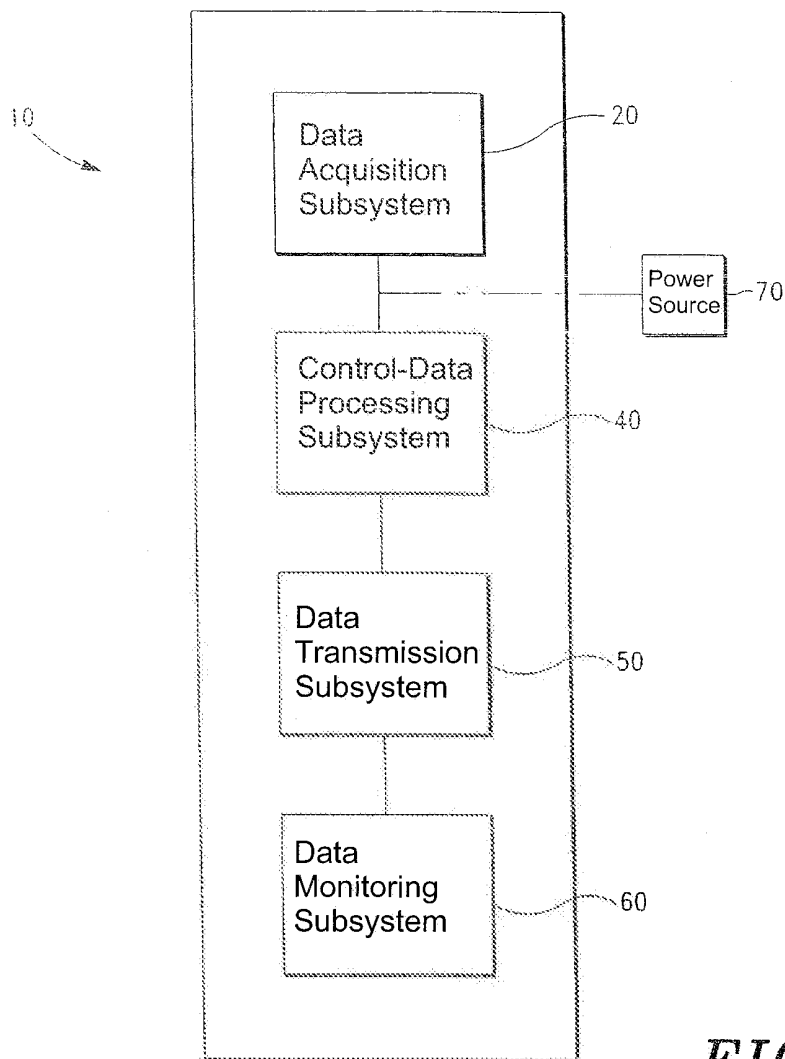

FIG. 1

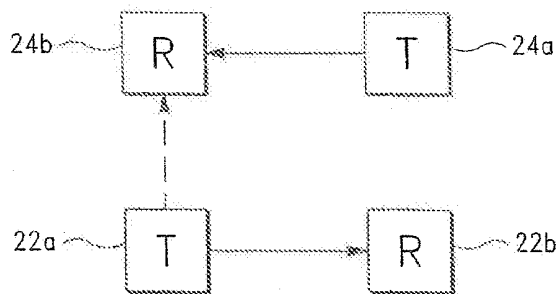

FIG. 2

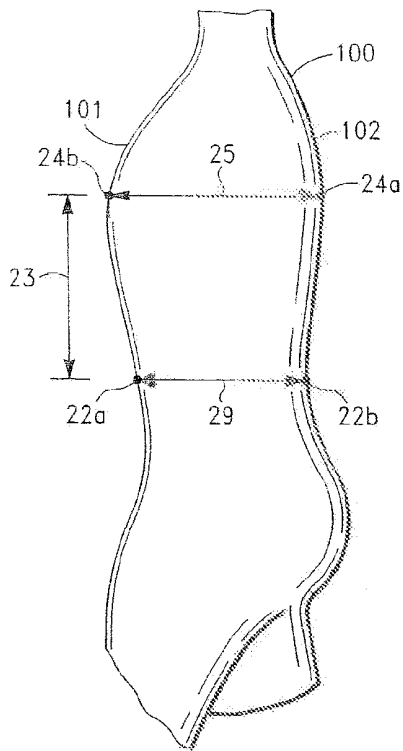

FIG. 3

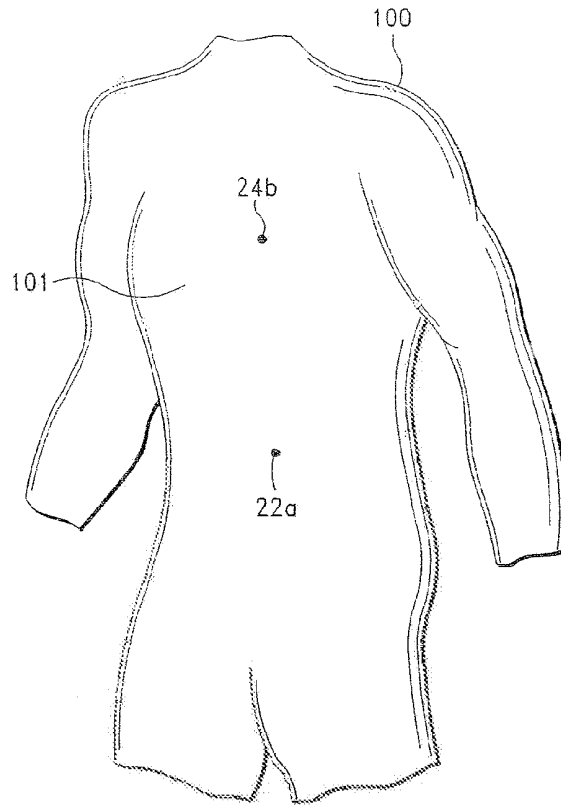

FIG. 4

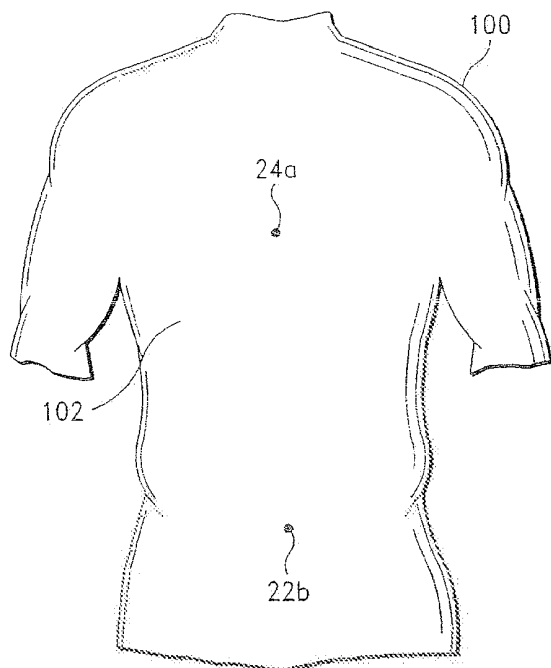

FIG. 5

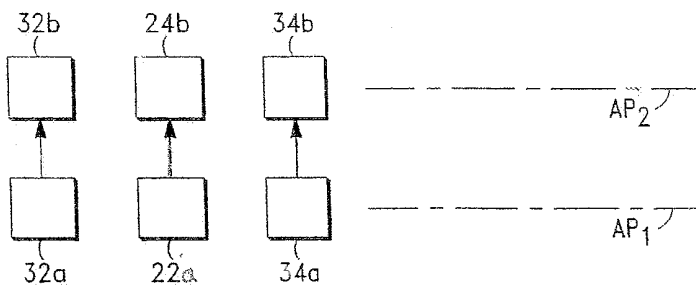

FIG. 6

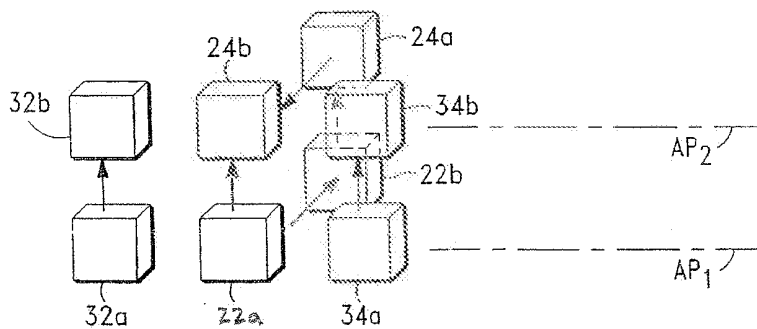

FIG. 7

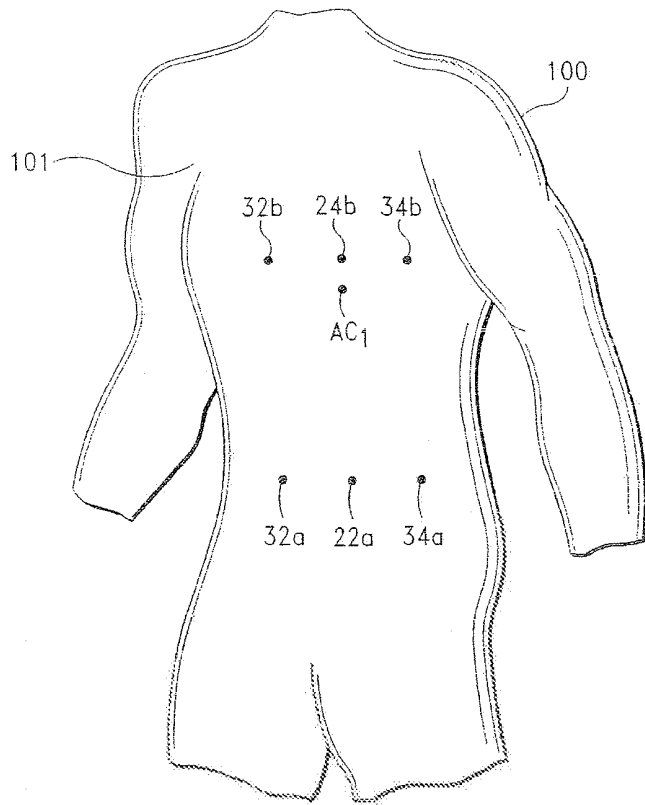

FIG. 8

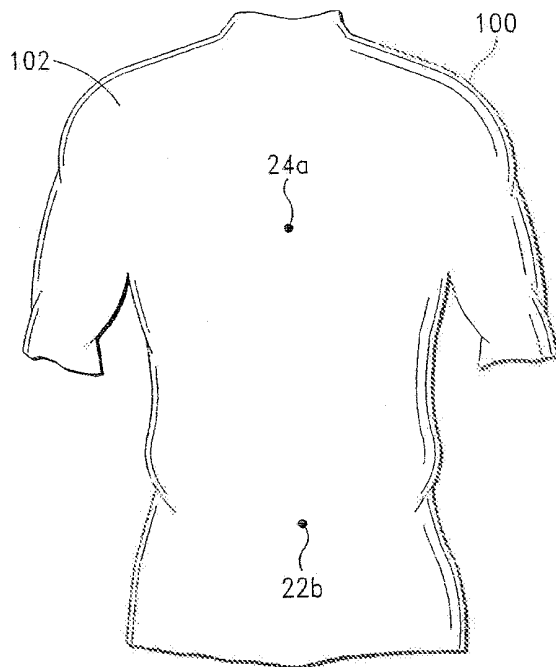

FIG. 9

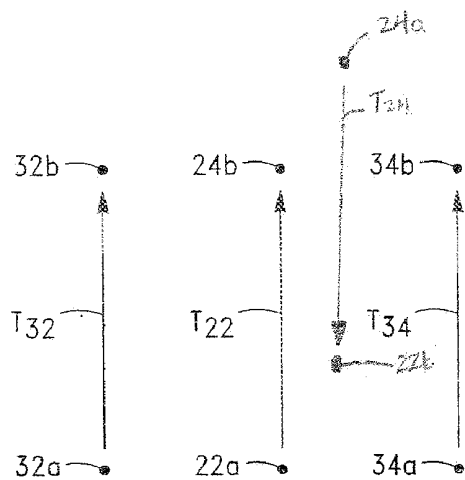

FIG. 10

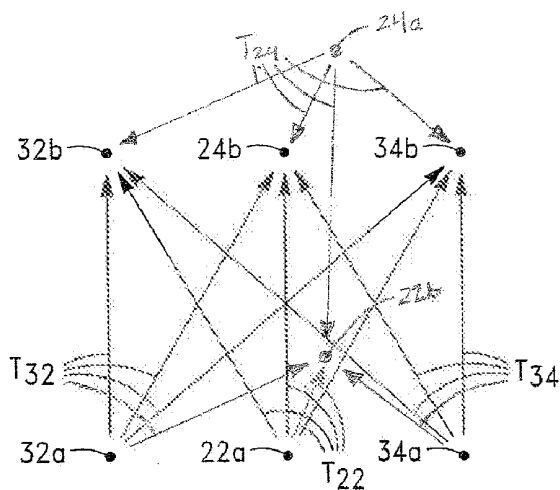

FIG. 11

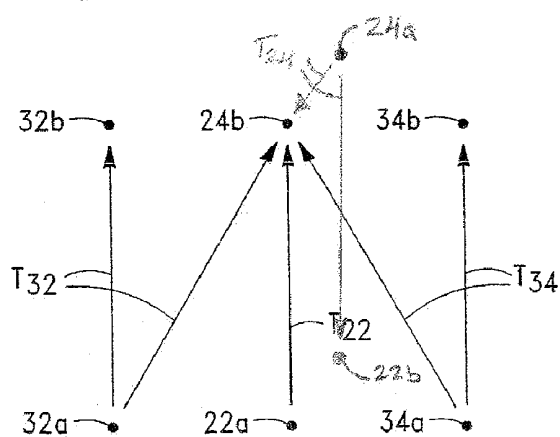

FIG. 12

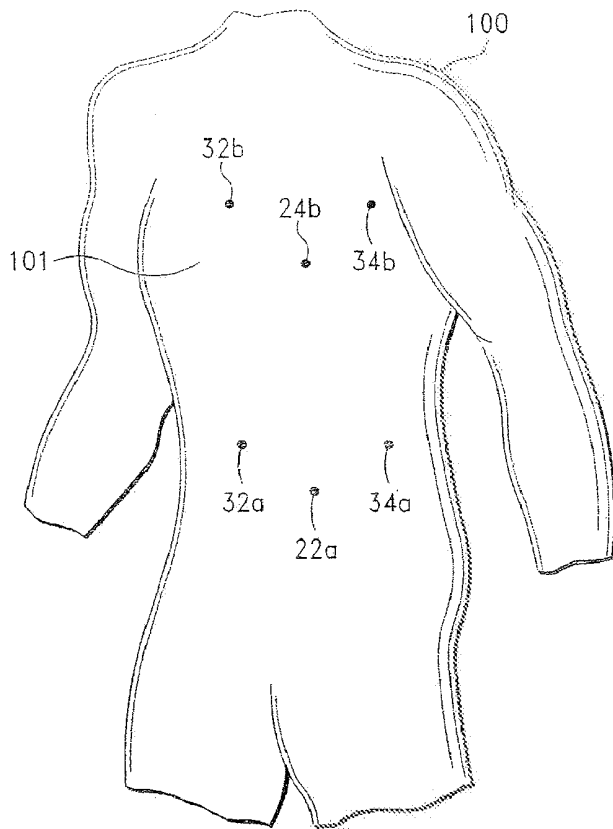

FIG. 13

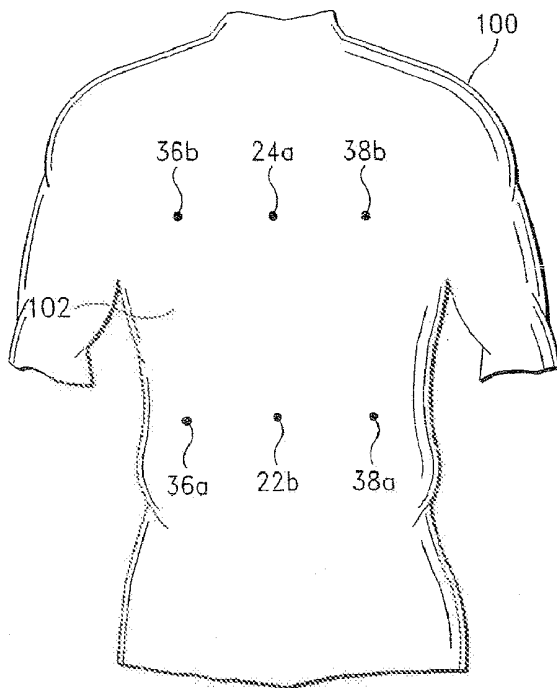

FIG. 14

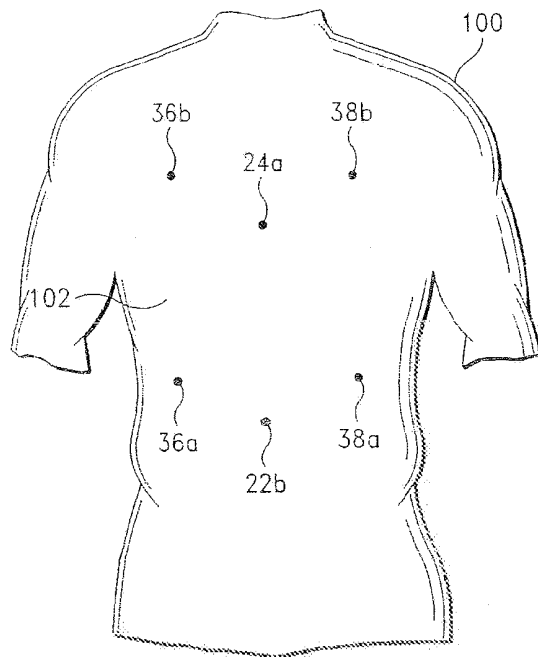

FIG. 15

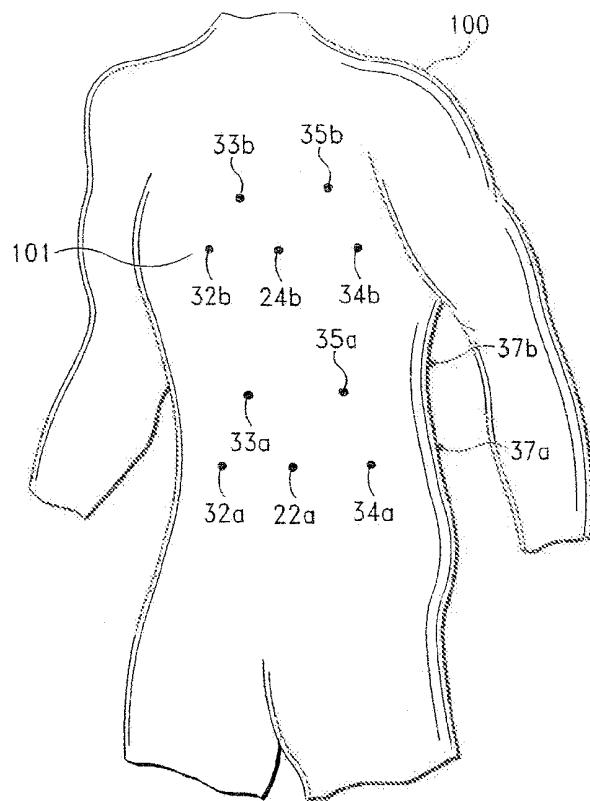

FIG. 16

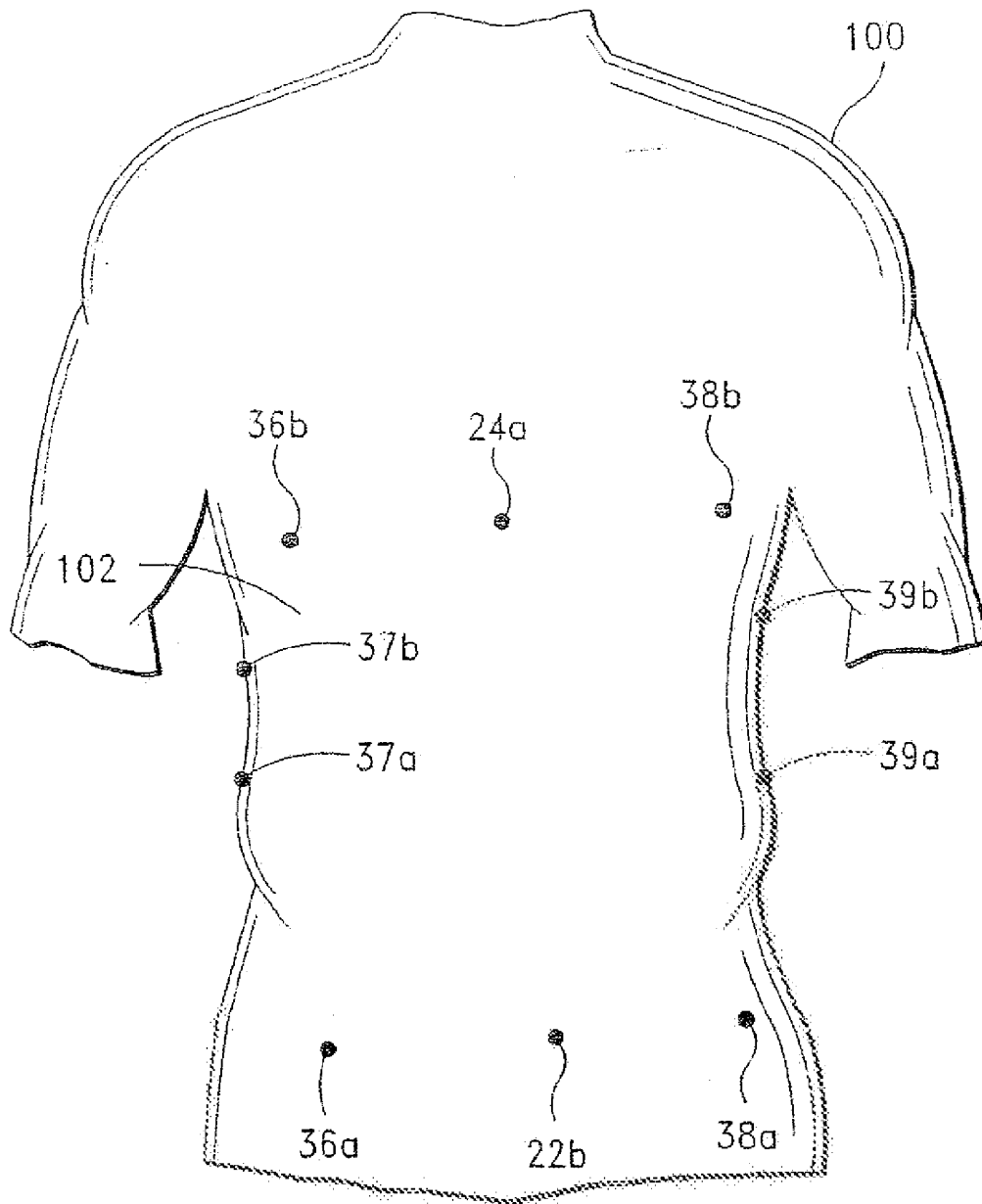

FIG. 17

**METHOD AND SYSTEM FOR MONITORING
PHYSIOLOGICAL AND ATHLETIC
PERFORMANCE CHARACTERISTICS OF A
SUBJECT**

**CROSS-REFERENCE TO RELATED
APPLICATIONS**

[0001] This non-provisional application claims priority to U.S. Provisional Application No. 61/275,586, filed Sep. 1, 2009, which is incorporated herein by reference in its entirety.

FIELD OF THE INVENTION

[0002] The present invention relates generally to methods and systems for monitoring physiological and athletic performance characteristics of a subject. More particularly, the invention relates to improved methods and systems for determining a plurality of physiological and athletic performance characteristics, and characterizing respiratory activity and associated events, as well as spatial parameters, in real time. The methods and systems of the present invention can be applied in a variety of fields, e.g., health care, medical diagnosis and monitoring, and athletic monitoring and coaching.

BACKGROUND OF THE INVENTION

[0003] In medical diagnosis and treatment of a subject, it is often necessary to assess one or more physiological characteristics; particularly, respiratory characteristics. A key respiratory characteristic is respiratory air volume (or tidal volume). Respiratory air volume and other respiratory characteristics are also useful to assess athletic performance, for example, by aiding in detection of changes in physiological state and/or performance characteristics.

[0004] Monitoring physiological and performance parameters of a subject can be important in planning and evaluating athletic training and activity. A subject may exercise or otherwise engage in athletic activity for a variety of reasons, including, for example, maintaining or achieving a level of fitness, to prepare for or engage in competition, and for enjoyment. The subject may have a training program tailored to his or her fitness level and designed to help him or her progress toward a fitness or exercise goal. Physiological and performance parameters of a subject can provide useful information about the subject's progression in a training program, or about the athletic performance of the subject. In order to accurately appraise the subject's fitness level or progress toward a goal, it may be useful to determine, monitor, and record various physiological or performance parameters, and related contextual information.

[0005] Various methods and systems utilizing heart rate have been introduced to approximate effort and physiological stress during exercise. Convenient, practicable, and comfortable means of measuring pulmonary ventilation in non-laboratory conditions, however, have been scarce. While of good value, heart rate can only give an approximation as to the true physiological state of an athlete or medical patient, as it can be confounded by external factors including, for example, sleep levels, caffeine, depressants, beta blockers, stress levels, hydration status, temperature, etc. Furthermore, accurate use of heart rate to gauge physiological performance requires knowledge of the amount of blood flowing to the muscles, which in turn requires knowledge of the instantaneous stroke volume of the heart as well as the rate of pumping. These

parameters can be difficult to determine while a subject is engaging in a physical activity.

[0006] Various conventional methods and systems have been employed to measure (or determine) tidal volume. One method includes having the patient or subject breathe into a mouthpiece connected to a flow rate measuring device. Flow rate is then integrated to provide air volume change.

[0007] As is well known in the art, there are several drawbacks and disadvantages associated with employing a mouthpiece. A significant drawback associated with a mouthpiece and nose-clip measuring device is that the noted items cause changes in the monitored subject's respiratory pattern (i.e., rate and volume). Tidal volume determinations based on a mouthpiece and nose-clip are, thus, often inaccurate.

[0008] A mouthpiece is difficult to use for monitoring athletic performance as well as for long term monitoring, especially for ill, sleeping, or anesthetized subjects. It is uncomfortable for the subject, tends to restrict breathing, and is generally inconvenient for the physician or technician to use. Monitoring respiratory characteristics using a mouthpiece is particularly impractical in the athletic performance monitoring context. During athletic activities, the mouthpiece interferes with the athlete's performance. The processing and collection accessories necessary to monitor the breathing patterns captured by the mouthpiece add further bulk to such devices. These systems also typically require an on-duty technician to set up and operate, further complicating their use.

[0009] Other conventional devices for determining tidal volume include respiration monitors. Illustrative are the systems disclosed in U.S. Pat. No. 3,831,586, issued Aug. 27, 1974 and U.S. Pat. No. 4,033,332, issued Jul. 5, 1977, each of which is incorporated by reference herein in its entirety.

[0010] Although the noted systems eliminate many of the disadvantages associated with a mouthpiece, the systems do not, in general, provide an accurate measurement of tidal volume. Further, the systems are typically only used to signal an attendant when a subject's breathing activity changes sharply or stops.

[0011] A further means for determining tidal volume is to measure the change in size (or displacement) of the rib cage and abdomen, as it is well known that lung volume is a function of these two parameters. A number of systems and devices have been employed to measure the change in size (i.e., A circumference) of the rib cage and abdomen, including mercury in rubber strain gauges, pneumobelts, respiratory inductive plethysmograph (RIP) belts, and magnetometers. See, D. L. Wade, "Movements of the Thoracic Cage and Diaphragm in Respiration", J. Physiol., pp. 124-193 (1954), Mead, et al., "Pulmonary Ventilation Measured from Body Surface Movements", Science, pp. 196, 1383-1384 (1967).

[0012] RIP belts are a common means employed to measure changes in the cross-sectional areas of the rib cage and abdomen. RIP belts include conductive loops of wire that are coiled and sewed into an elastic belt. As the coil stretches and contracts in response to changes in a subject's chest cavity size, a magnetic field generated by the wire changes. The output voltage of an RIP belt is generally linearly related to changes in the expanded length of the belt and, thus, changes in the enclosed cross-sectional area.

[0013] In practice, measuring changes in the cross-sectional areas of the abdomen can increase the accuracy of RIP belt systems. To measure changes in the cross-sectional areas

of the rib cage and abdomen, one belt is typically secured around the mid-thorax and a second belt is typically placed around the mid-abdomen.

[0014] RIP belts can also be embedded in a garment, such as a shirt or vest, and appropriately positioned therein to measure rib cage and abdominal displacements, and other anatomical and physiological parameters, such as jugular venous pulse, respiration-related intra-plural pressure changes, etc. Illustrative is the VivoMetrics, Inc. LifeShirt® disclosed in U.S. Pat. No. 6,551,252, issued Apr. 22, 2003 and U.S. Pat. No. 6,341,504, issued Jan. 29, 2002, each of which is incorporated by reference herein in its entirety.

[0015] There are some drawbacks, however, to many RIP belt systems. For example, RIP belts are expensive in terms of material construction and in terms of the electrical and computing power required to operate them. In addition, the coils are generally large and tight on the chest and therefore can be cumbersome and uncomfortable for the athlete.

[0016] Other technologies have been developed in an attempt to monitor respiratory characteristics of a subject while avoiding the drawbacks of RIP belt systems. These Technologies generally work on a strain gauge principle and are often textile based. However, such technologies suffer significantly from motion interference that, by and large, renders them useless in athletic training applications where motion is necessarily at a relatively high level.

[0017] In an attempt to rectify the drawbacks of the RIP belt and strain gauge systems, various magnetometer systems have been recently developed to measure displacements of the rib cage and abdomen. Respiratory magnetometer systems typically comprise one or more tuned pairs of air-core magnetometers or electromagnetic coils. Other types of magnetometers sensitive to changes in distance therebetween can also be used. One magnetometer is adapted to transmit a specific high frequency AC magnetic field and the other magnetometer is adapted to receive the field. The paired magnetometers are responsive to changes in a spaced distance therebetween; the changes being reflected in changes in the strength of the magnetic field.

[0018] To measure changes in (or displacement of) the anteroposterior diameter of the rib cage, a first magnetometer is typically placed over the sternum at the level of the 4th intercostal space and the second magnetometer is placed over the spine at the same level. Using additional magnetometers can increase the accuracy of the magnetometer system. For example, to measure changes in the anteroposterior diameter of the abdomen, a third magnetometer can be placed on the abdomen at the level of the umbilicus and a fourth magnetometer can be placed over the spine at the same level.

[0019] Over the operational range of distances, the output voltage is linearly related to the distance between two magnetometers provided that the axes of the magnetometers remain substantially parallel to each other. As rotation of the axes can change the voltage, the magnetometers are typically secured to the subject's skin in a parallel fashion and rotation due to the motion of underlying soft tissue is minimized.

[0020] As set forth herein, magnetometers can also be embedded in or carried by a wearable garment, such as a shirt or vest. The wearable monitoring garment eliminates the need to attach the magnetometers directly to the skin of a subject and, hence, resolves all issues related thereto. The wearable monitoring garment also facilitates repeated and convenient positioning of magnetometers at virtually any appropriate (or desired) position on a subject's torso.

[0021] Various methods, algorithms, and mathematical models have been employed with the aforementioned systems to determine tidal volume and other respiratory characteristics. In practice, "two-degrees-of-freedom" models are typically employed to determine tidal volume from RIP belt-derived rib cage and abdominal displacements.

[0022] The "two-degrees-of-freedom" models are premised on the inter-related movements by and between the thoracic cavity and the anterior and lateral walls of the rib cage and the abdomen, i.e., since the first rib and adjacent structures of the neck are relatively immobile, the moveable components of the thoracic cavity are taken to be the anterior and lateral walls of the rib cage and the abdomen. Changes in volume of the thoracic cavity will then be reflected by displacements of the rib cage and abdomen.

[0023] As is well known in the art, displacement (i.e., movement) of the rib cage can be directly assessed with an RIP belt. Diaphragm displacement cannot, however, be measured directly. But, since the abdominal contents are essentially incompressible, caudal motion of the diaphragm relative to the pelvis and the volume it displaces is reflected by outward movement of the anterolateral abdominal wall.

[0024] The "two-degrees-of-freedom" model embraced by many in the field holds that tidal volume (V_T) is equal to the sum of the volume displacements of the rib cage and abdomen, i.e.:

$$V_T = \alpha RC + \beta Ab \quad \text{Eq. 1}$$

where RC and Ab represent linear displacements of the rib cage and abdomen, respectively, and α and β represent volume-motion coefficients.

[0025] The accuracy of the "two-degrees-of-freedom" model and, hence, methods employing same to determine volume-motion coefficients of the rib cage and abdomen, is limited by virtue of changes in spinal flexion that can accompany changes in posture. It has been found that V_T can be over or under-estimated by as much as 50% of the vital capacity with spinal flexion and extension. See, McCool, et al., "Estimates of Ventilation From Body Surface Measurements in Unrestrained Subjects", J. Appl. Physiol., vol. 61, pp. 1114-1119 (1986) and Paek, et al., "Postural Effects on Measurements of Tidal Volume From Body Surface Displacements", J. Appl. Physiol., vol. 68, pp. 2482-2487 (1990).

[0026] There are two major causes that contribute to the noted error and, hence, limitation. A first contributing cause of the error is due to the substantial displacement of the summed rib cage and abdomen signals that occurs with isovolume spinal flexion and extension or pelvic rotation.

[0027] The second contributing cause of the error is due to posturally-induced changes in volume-motion coefficients. With isovolume spinal flexion, the rib cage comes down with respect to the pelvis and the axial dimension of the anterior abdominal wall becomes smaller. Therefore, less abdominal cavity is bordered by the anterior abdominal wall.

[0028] With a smaller anterior abdominal wall surface to displace, a given volume displacement of the abdominal compartment would be accompanied by a greater outward displacement of the anterior abdominal wall. The abdominal volume-motion coefficient would accordingly be reduced.

[0029] It has, however, been found that the addition of a measure of the axial motion of the chest wall e.g., changes in the distance between the xiphoid and the pubic symphysis (X_i), provides a third degree of freedom, which, when employed to determine tidal volume (V_T) can reduce the

posture related error associated with the “two-degrees-of-freedom” model to within 15% of that measured by spirometry. See, Paek, et al., “*Postural Effects on Measurements of Tidal Volume From Body Surface Displacements*”, J. Appl. Physiol., vol. 68, pp. 2482-2487 (1990); and Smith, et al., “*Three Degree of Freedom Description of Movement of the Human Chest Wall*”, J. Appl. Physiol., Vol. 60, pp. 928-934 (1986).

[0030] Several magnetometer systems are thus adapted to additionally measure the displacement of the chest wall. Illustrative are the magnetometer systems disclosed in co-pending U.S. patent application Ser. No. 12/231,692, filed Sep. 5, 2008, which is incorporated by reference herein in its entirety.

[0031] Various methods, algorithms and models are similarly employed with the magnetometer systems to determine tidal volume (V_T) and other respiratory characteristics based on measured displacements of the rib cage, abdomen, and chest wall. The model embraced by many in the field is set forth in Equation 2 below:

$$V_T = \alpha(\Delta RC) + \beta(\Delta Ab) + \gamma(\Delta Xi) \quad \text{Eq. 2}$$

where:

ΔRC represents the linear displacement of the rib cage;
 ΔAb represents the linear displacement of the abdomen;
 ΔXi represents axial displacement of the chest wall;
 α represents a rib cage volume-motion coefficient;
 β represents an abdominal volume-motion coefficient; and
 γ represents a chest wall volume-motion coefficient.

[0032] There are, however, similarly several drawbacks and disadvantages associated with the noted “three-degrees-of-freedom” model. A major drawback is that posture related errors in tidal volume determinations are highly probable when a subject is involved in freely moving postural tasks, e.g., bending, wherein spinal flexion and/or extension is exhibited.

[0033] The most pronounced effect of spinal flexion is on the abdominal volume-motion coefficient (β). With bending, β decreases as the xiphi-umbilical distance decreases.

[0034] Various approaches and models have thus been developed to address the noted dependency and, hence, enhance the accuracy of tidal volume (V_T) determinations. In co-pending U.S. patent application Ser. No. 12/231,692, a modified “three-degrees-of-freedom” model is employed to address the dependence of β on the xiphi-umbilical distance, i.e.:

$$V_T = \alpha(\Delta RC) + (\beta_u + \epsilon Xi) \times (\Delta Ab) + \gamma(\Delta Xi) \quad \text{Eq. 3}$$

where:

ΔRC represents the linear displacement of the rib cage;
 ΔAb represents the linear displacement of the abdomen;
 ΔXi represents the change in the xiphi-umbilical distance from an upright position;
 α represents a rib cage volume-motion coefficient;
 β represents an abdominal volume-motion coefficient;
 β_u represents the value of the abdominal volume-motion coefficient (β) in the upright position;
 ϵ represents the linear slope of the relationship of β as a function of the xiphi-umbilical distance Xi ;
 $(\beta_u + \epsilon Xi)$ represents the corrected abdominal volume-motion coefficient; and
 γ represents a xiphi-umbilical volume-motion coefficient.

[0035] The “three-degrees-of-freedom” model reflected in Equation 3 above and the associated magnetometer systems and methods disclosed in co-pending U.S. patent application Ser. No. 12/231,692 have been found to reduce the posture

related error(s) in tidal volume (V_T) and other respiratory characteristic determinations. There are, however, several issues with the disclosed magnetometer systems and methods. One issue is that the magnetometer systems require complex calibration algorithms and associated techniques to accurately determine tidal volume (V_T) and other respiratory characteristics. A further issue, which is discussed in detail herein, is that the chest wall and respiratory data provided by the disclosed systems (and associated methods) is limited and, hence, limits the scope of respiratory characteristics and activity determined therefrom.

BRIEF SUMMARY OF THE INVENTION

[0036] The present invention provides apparatuses and methods for improved monitoring of a subject’s respiratory characteristics, which is of particular use in the fields of athletic performance monitoring and medical evaluation. In accordance with the above objects and those that will be mentioned and will become apparent below, a fitness monitoring system for monitoring a subject engaged in a physical activity, in accordance with one embodiment of the invention, includes a first subsystem including a first plurality of paired electromagnetic coils disposed proximate to a subject, the first subsystem being configured to generate and transmit a plurality of coil signals, each of the plurality of coil signals representing a change in the distance between a pair of electromagnetic coils, and a second subsystem in communication with the first subsystem, the second subsystem being configured to receive the plurality of coil signals.

[0037] The monitoring system can be configured to measure and/or calculate various performance parameters associated with an athlete’s physical activity, as explained in further detail below.

[0038] The monitoring system may include or communicate with one or more sensors for detecting information used to measure and/or calculate performance parameters. Suitable sensors may include, for example, the sensors disclosed in commonly owned U.S. patent application Ser. No. 11/892,023, filed Feb. 19, 2009, titled “Sports Electronic Training System, and Applications Thereof”, commonly owned U.S. patent application Ser. No. 12/467,944, filed May 18, 2009, titled “Portable Fitness Monitoring Systems, and Applications Thereof”, and commonly owned U.S. patent application Ser. No. 12/836,421, filed Jul. 14, 2010, titled “Fitness Monitoring Methods, Systems, and Program Products, and Applications Thereof”, each of which is incorporated by reference herein in its entirety.

[0039] In accordance with another embodiment of the invention, a method for monitoring a subject engaged in a physical activity is provided. The method includes transmitting a plurality of coil signals, wherein the plurality of coil signals is generated by a first plurality of paired electromagnetic coils disposed proximate to a subject, and wherein each of the plurality of coil signals is representative of a change in the distance between a pair of electromagnetic coils, and receiving the plurality of coil signals.

[0040] In accordance with another embodiment of the invention, a monitoring system for noninvasively monitoring physiological parameters of a subject is provided. The monitoring system includes (i) a magnetometer subsystem having a first plurality of paired magnetometers, each of the first plurality of paired magnetometers being responsive to changes in a spaced distance therebetween, the magnetometer subsystem being adapted to generate and transmit a plu-

rality of magnetometer signals, each of the magnetometer signals representing a change in spaced distance between a respective one of the first plurality of paired magnetometers, the first plurality of paired magnetometers being positioned at a plurality of first spaced magnetometer positions, at least a second plurality of the first plurality of paired magnetometers being positioned at second spaced magnetometer positions proximate the subject's chest region, and (ii) a processor subsystem in communication with the magnetometer subsystem and adapted to receive the plurality of magnetometer signals, the processor subsystem being programmed and adapted to control the magnetometer subsystem, the processor subsystem being further programmed and adapted to process the magnetometer signals, the processor subsystem including at least one empirical relationship for determining at least one respiratory characteristic from the plurality of magnetometer signals, and adapted to generate and transmit at least one respiratory characteristic signal representing the respiratory characteristic.

[0041] In accordance with another embodiment of the invention, the monitoring system includes a data monitoring subsystem programmed and adapted to receive the respiratory characteristic signal, the data monitoring subsystem being programmed and adapted to recognize and display the respiratory characteristic represented by the respiratory characteristic signal.

[0042] In accordance with another embodiment of the invention, the monitoring system includes a transmission subsystem adapted to control transmission of the first plurality of magnetometer signals from the magnetometer subsystem to the processor subsystem and the respiratory characteristic signal from the processor subsystem to the data monitoring subsystem.

[0043] In accordance with another embodiment of the invention, the transmission subsystem includes a wireless communication network.

[0044] In accordance with another embodiment of the invention, the monitoring system includes at least one physiological sensor adapted to detect at least one physiological characteristic associated with the subject, the physiological sensor being further adapted to generate and transmit at least one physiological parameter signal representing the detected physiological characteristic.

[0045] In accordance with another embodiment of the invention, the monitoring system includes at least one spatial parameter sensor adapted to detect orientation and motion of the subject, the spatial parameter sensor being further adapted to generate and transmit a first spatial parameter signal representing a detected orientation of the subject and a second spatial parameter signal representing a detected motion of the subject.

[0046] In accordance with another embodiment of the invention, the processor subsystem is further programmed and adapted to determine movement of the subject's chest wall based on the first plurality of magnetometer signals, and to generate and transmit a chest wall signal representing the chest wall movement.

[0047] In accordance with another embodiment of the invention, the processor subsystem is further programmed and adapted to determine at least one respiratory activity of the subject based on the chest wall movement, and to generate and transmit a respiratory activity signal representing the respiratory activity.

[0048] In accordance with another embodiment of the invention, the processor subsystem is further programmed and adapted to generate at least one three-dimensional model of the subject's chest wall from the first plurality of magnetometer signals.

[0049] In accordance with another embodiment of the invention, the processor subsystem includes a plurality of stored adverse physiological characteristics, and the processor subsystem is further programmed and adapted to compare the detected physiological characteristic to the plurality of stored adverse physiological characteristics, and to generate and transmit a warning signal if the detected physiological characteristic is one of the plurality of stored adverse physiological characteristics.

[0050] In accordance with another embodiment of the invention, the processor subsystem includes a first plurality of chest wall parameters, each of the first plurality of chest wall parameters having at least a third plurality of magnetometer signals and at least a first spatial parameter associated therewith, each of the first plurality of chest wall parameters representing a first respiratory characteristic and first anatomical parameter.

[0051] In accordance with another embodiment of the invention, the processor subsystem is further programmed and adapted to compare the first plurality of magnetometer signals and the spatial parameter signals to the first plurality of chest wall parameters, to select a respective one of the first plurality of chest wall parameters based on the first plurality of magnetometer signals and the spatial parameter signals, and to generate and transmit at least a first chest wall parameter signal representing the selected first chest wall parameter.

BRIEF DESCRIPTION OF THE FIGURES

[0052] Further features and advantages will become apparent from the following and more particular description of the present invention, as illustrated in the accompanying drawings, and in which like referenced characters generally refer to the same parts or elements throughout the views.

[0053] FIG. 1 is a schematic illustration of a physiological monitoring system, according to one embodiment of the invention.

[0054] FIG. 2 is a schematic illustration of a dual-paired electromagnetic coil arrangement, according to one embodiment of the invention.

[0055] FIG. 3 is a side view of a subject, showing the position of the dual-paired electromagnetic coil arrangement of FIG. 2 on the subject, according to one embodiment of the invention.

[0056] FIG. 4 is a perspective view of the subject, showing the position of electromagnetic coils on the front of the subject, according to one embodiment of the invention.

[0057] FIG. 5 is a plane view of the subject's back, showing the position of electromagnetic coils thereon, according to one embodiment of the invention.

[0058] FIGS. 6 and 7 are schematic illustrations of a multiple-paired electromagnetic coil arrangement, according to one embodiment of the invention.

[0059] FIG. 8 is a perspective view of a subject, showing the position of the multiple-paired electromagnetic coils shown in FIG. 6 on the front of the subject, according to one embodiment of the invention.

[0060] FIG. 9 is a plane view of the subject's back, showing the position of electromagnetic coils thereon, according to one embodiment of the invention.

[0061] FIG. 10-12 are schematic illustrations of coil transmission axes provided by several multiple-paired coil embodiments of the invention.

[0062] FIG. 13 is a perspective view of a subject, showing alternative positions of the multiple-paired electromagnetic coils shown in FIG. 6 on the front of the subject, according to another embodiment of the invention.

[0063] FIG. 14 is a plane view of the subject's back, showing the positioning of three pairs of electromagnetic coils thereon, according to another embodiment of the invention.

[0064] FIG. 15 is a plane view of the subject's back, showing alternative positions of the paired electromagnetic coils shown in FIG. 14 thereon, according to another embodiment of the invention.

[0065] FIG. 16 is a perspective view of a subject, showing the position of six pairs of electromagnetic coils on the front and one side of the subject, according to another embodiment of the invention.

[0066] FIG. 17 is a plane view of the subject's back, showing the position of five pairs of electromagnetic coils on the back and both sides of the subject, according to another embodiment of the invention.

DETAILED DESCRIPTION OF THE INVENTION

[0067] Before describing the present invention in detail, it is to be understood that this invention is not limited to particularly exemplified methods, apparatuses, systems, or circuits, as such may, of course, vary. Thus, although a number of methods and systems similar or equivalent to those described herein can be used in the practice of the present invention, the preferred methods, apparatus and systems are described herein.

[0068] It is also to be understood that the terminology used herein is for the purpose of describing particular embodiments of the invention only and is not intended to be limiting.

[0069] Unless defined otherwise, all technical and scientific terms used herein have the same meaning as commonly understood by one having ordinary skill in the art to which the invention pertains.

[0070] As used in this specification and the appended claims, the singular forms "a", "an", and "the" include plural referents unless the content clearly dictates otherwise.

[0071] Further, all publications, patents, and patent applications cited herein, whether supra or infra, are hereby incorporated by reference in their entirety.

[0072] The publications discussed herein are provided solely for their disclosure prior to the filing date of the present application. Nothing herein is to be construed as an admission that the present invention is not entitled to antedate such publication(s) by virtue of prior invention. Further, the dates of publication may be different from the actual publication dates, which may need to be independently confirmed.

DEFINITIONS

[0073] The terms "respiratory parameter" and "respiratory characteristic", as used herein, mean and include a characteristic associated with the respiratory system and functioning thereof, including, without limitation, breathing frequency (fB), tidal volume (V_T), inspiration volume (V_I), expiration volume (V_E), minute ventilation (VE), inspiratory breathing time, expiratory breathing time, and flow rates (e.g., rates of change in the chest wall volume). The terms "respiratory parameter" and "respiratory characteristic" further mean and

include inferences regarding ventilatory mechanics from synchronous or asynchronous movements of the chest wall compartments.

[0074] According to the present invention, flow rates and respiratory accelerations can be determined from a volume signal. Further, numerous inferences regarding ventilatory mechanics can be drawn from the degree of asynchrony in movement occurring amongst the discrete compartments that make up the chest wall.

[0075] The terms "respiratory system disorder", "respiratory disorder", and "adverse respiratory event", as used herein, mean and include any dysfunction of the respiratory system that impedes the normal respiration or ventilation process.

[0076] The terms "physiological parameter" and "physiological characteristic", as used herein, mean and include, without limitation, electrical activity of the heart, electrical activity of other muscles, electrical activity of the brain, pulse rate, blood pressure, blood oxygen saturation level, skin temperature, and core temperature.

[0077] The terms "spatial parameter" and "spatial characteristic", as used herein, mean and include a subject's orientation and/or movement.

[0078] The terms "patient" and "subject", as used herein, mean and include humans and animals.

[0079] Pulmonary ventilation, tidal volume, respiratory rate, and other associated respiratory characteristics can provide a reliable and practical measure of oxygen and carbon dioxide transpiration in a living body. Respiratory characteristics are directly related to exercise effort, physiological stress, and other physiological characteristics. One way to externally determine tidal volume is to measure the change in thoracic volume. Change in thoracic volume is caused by the expansion and contraction of the lungs. As the gas pressure in the lungs at the maxima and minima of the pressure ranges is equilibrated to surrounding air pressure, there is a very close and monotonic relationship between the volume of the lungs and the volume of air inspired.

[0080] Accurate measurement of the change in thoracic volume involves measuring the change in the diameter of the chest at the ribcage. Measurement of the change in the diameter of the chest below the ribcage can provide additional accuracy to the measurement. Monitoring changes in the diameter of the chest below the ribcage can account for diaphragm delivered breathing where the contraction and relaxation of the diaphragm muscle causes the organs of the abdomen to be pushed down and outwards, thereby increasing the available volume of the lungs.

[0081] Monitoring and analyzing respiratory characteristics can be particularly useful in athletic applications, as there is a direct link between performance and an athlete's processing of oxygen and carbon dioxide. For example, in many athletic training situations, it is helpful to know when the athlete's body transitions between aerobic exercise and anaerobic exercise, sometimes referred to as the athlete's ventilatory threshold. Crossing over the ventilatory threshold level is an indicator of pending performance limitations during sport activities. For example, it can be beneficial for athletes to train in the anaerobic state for limited periods of time. However, for many sports, proper training requires only limited periods of anaerobic exercise interrupted by lower intensity aerobic exercises. It is difficult for an athlete to determine which state, anaerobic or aerobic, he or she is in without referencing physiological characteristics such as res-

piratory characteristics. Therefore, respiratory monitoring and data processing can provide substantial benefits in athletic training by allowing for accurate and substantially instantaneous measurements of the athlete's exercise state. Changes in an athlete's ventilatory threshold over time, as well as patterns of tidal volume during post-exercise recovery, can be valuable to measure improvements in the athlete's fitness level over the course of a training regime. Respiratory monitoring can further allow for monitoring and analyzing changes in a subject's resting metabolic rate.

[0082] A second ventilatory threshold exists at the point when the load on the body is such that the pulmonary ventilation is no longer sufficient to support life sustainably. Dwelling too long in this state will lead to collapse and so determination of this point can be of value in medical applications, and particularly to first responders and other emergency response personnel.

[0083] As indicated above, the present invention is directed to noninvasive methods and associated systems for monitoring the physiological status of a subject; particularly, the status of the subject's respiratory system. Magnetometers can be used, and can be embedded in or carried by a wearable garment, such as a shirt or vest. The wearable monitoring garment eliminates the need to attach the magnetometers directly to the skin of a subject and, hence, resolves all issues related thereto. The wearable monitoring garment also facilitates repeated and convenient positioning of magnetometers at virtually any appropriate (or desired) position on a subject's torso.

[0084] As will be readily appreciated by one having ordinary skill in the art, the methods and systems of the invention provide numerous significant advantages over conventional methods and systems for monitoring physiological status. Among the advantages are the provision of physiology monitoring methods and systems that provide (i) accurate, real-time determination of a plurality of physiological characteristics, (ii) accurate determination of a plurality of respiratory parameters and characteristics, (iii) accurate assessment of chest wall movement(s) and the relationship(s) thereof to respiratory activity and respiratory associated events, such as speaking and coughing, (iv) real-time determination and characterization of respiratory events, and (v) real-time determination and characterization of a subject's orientation and movement.

[0085] A further significant advantage is the provision of additional and pertinent data relating to chest wall movement that facilitates three-dimensional modeling of chest wall shape and movement of ambulatory subjects.

[0086] Another significant advantage of the present invention is the provision of systems and associated methods that facilitate evaluation and quantification of ventilatory mechanics, e.g., synchronous and asynchronous movement of the chest wall compartments. As will readily be appreciated by one having ordinary skill in the art, this has implications in many fields of use, including applications related to specific disease states, such as asthma and chronic obstructive pulmonary disease (COPD), and acute disease states, such as pneumo-thorax and pulmonary embolism.

[0087] Another advantage of the present invention is the provision of systems for accurately determining tidal volume (V_T) and other respiratory characteristics that do not require complex calibration algorithms and associated methods. This

similarly has significant implications in many fields of use, including applications related to specific disease states, such as COPD.

[0088] Several embodiments of the physiology monitoring systems and associated methods of the invention will now be described in detail. It is understood that the invention is not limited to the systems and associated methods described herein. Indeed, as will be appreciated by one having ordinary skill in the art, systems and associated methods similar or equivalent to the described systems and methods can also be employed within the scope of the present invention.

[0089] Further, although the physiology monitoring systems and associated methods are described herein in connection with monitoring physiological parameters and characteristics in a human body, the invention is in no way limited to such use. The physiology monitoring systems and associated methods of the invention can also be employed to monitor physiological parameters in non-human bodies. The physiology monitoring systems and associated methods of the invention can also be employed in non-medical contexts, e.g., determining volumes and/or volume changes in extensible bladders used for containing liquids and/or gasses.

[0090] Referring first to FIG. 1, there is shown a schematic illustration of one embodiment of a physiology monitoring system according to the present invention. As illustrated in FIG. 1, the physiology monitoring system 10 preferably includes a data acquisition subsystem 20, a control-data processing subsystem 40, a data transmission subsystem 50, a data monitoring subsystem 60, and a power source 70, such as a battery.

Data Acquisition Subsystem

[0091] In accordance with one embodiment of the invention, the data acquisition subsystem 20 includes means for acquiring anatomical parameters that can be employed to determine at least one respiratory characteristic, more preferably a plurality of respiratory characteristics, in cooperation with control-data processing subsystem 40, and, in some embodiments, data monitoring subsystem 60. The anatomical parameters may include changes in (or displacements of) the anteroposterior diameters of the rib cage and abdomen, and axial displacement of the chest wall. The means for acquiring the noted parameters, e.g., sensors. The sensors can include paired electromagnetic coils or magnetometers.

[0092] Although the present invention is described herein in terms of magnetometers and magnetometer systems, it is understood that other types of sensor systems capable of measuring changes in distance between two or more sensors in the system can be used in place of, or in addition to, magnetometers. Specifically, the invention is not limited to the use of electromagnetic coils or magnetometers to measure changes in the anteroposterior diameters of the rib cage and abdomen, and axial displacement of the chest wall. Various additional means and devices that can be readily adapted to measure the noted anatomical parameters can be employed within the scope of the invention. Such means and devices include, without limitation, Hall effect sensors and electronic compass sensors. Wireless sensors with the capability of measuring time delay in a signal sent from one sensor to another and thereby determine the distance between the two sensors can be substituted for or provided in addition to magnetometers in accordance with the present invention.

[0093] According to the invention, at least two magnetometers can be employed to measure the noted subject param-

eters (or displacements). In some embodiments of the invention, two pairs of magnetometers are employed. In some embodiments, more than two pairs of magnetometers are employed.

[0094] Referring now to FIG. 2, there is shown one embodiment of a dual-paired electromagnetic coil arrangement for detecting and measuring displacement(s) of the rib cage, abdomen, and chest wall. As illustrated in FIG. 2, the electromagnetic coils include first transmission and receive coils **22a**, **22b**, and second transmission and receive coils **24a**, **24b**. In FIG. 2, the letter T designates the transmission coils and the letter R designates the receiving coils, however, the coils are not limited to such designations. The electromagnetic coils of embodiments of the present invention are described as "receiving" or "transmitting," however, each receiving coil can alternatively and independently be a transmitting coil, and each transmitting coil can alternatively and independently be a transmitting coil. Coils can also perform both receiving and transmitting functions.

[0095] Details of the noted arrangement and associated embodiments (discussed below) are set forth in co-pending U.S. patent application Ser. No. 12/231,692, filed Sep. 5, 2008, co-pending U.S. Patent Application No. 61/275,576, filed Sep. 1, 2009, and co-pending U.S. patent application Ser. No. _____ [Attorney Docket No. 3483.0260001], filed concurrently herewith, each of which, as indicated above, is expressly incorporated by reference herein in its entirety.

[0096] As set forth in the noted applications, in some embodiments of the invention, at least receive coil **24b** is adapted to receive coil transmissions from each of transmission coils **22a**, **24a** (i.e., at least receive coil **24b** may be a dual function coil, where "dual function coil" refers to a coil capable of receiving transmissions from a plurality of different transmission coils). In some embodiments, each receive coil **22b**, **24b** is adapted to receive transmissions from each transmission coil **22a**, **24a**.

[0097] Referring now to FIGS. 3-5, there is shown the position of coils **22a**, **22b**, **24a**, **24b** on a subject or patient **100**, in accordance with one embodiment of the invention. As illustrated in FIGS. 3-5, first transmission coil **22a** is preferably positioned on front **101** of subject **100** proximate the umbilicus of subject **100**, and first receive coil **22b** is preferably positioned proximate the same axial position, but on back **102** of subject **100**. Second receive coil **24b** is preferably positioned on front **101** of subject **100** proximate the base of the sternum, and second transmission coil **24a** is preferably positioned proximate the same axial position, but on back **102** of subject **100**.

[0098] As set forth in co-pending U.S. patent application Ser. No. 12/231,692, the positions of transmission coils **22a**, **24a** and receive coils **22b**, **24b** can be reversed (i.e., transmission coil **22a** and receive coil **24b** can be placed on back **102** of subject **100** and transmission coil **24a** and receive coil **22b** can be placed on front **101** of subject **100**. Both transmission coils **22a** and **24a** can also be placed on front **101** or back **102** of subject **100** and receive coils **22b** and **24b** can be placed on the opposite side.

[0099] Referring back to FIG. 3, an arrow **23** represents the chest wall or, in this instance, the xiphi-umbilical distance (Xi) that is monitored. An arrow **25** represents the monitored rib cage distance, while an arrow **29** represents the monitored abdominal distance.

[0100] In accordance with one embodiment of the invention, wherein coil **24b** is a dual function coil, as subject or

patient **100** breathes, displacement(s) of the rib cage and abdomen (i.e., changes in the distance between each pair of coils **22a**, **22b** and **24a**, **24b**, denoted, respectively, by arrow **29** and arrow **25**), is determined from measured changes in voltage between paired coils **22a**, **22b** and **24a**, **24b**. The axial displacement of the chest wall, denoted by arrow **23**, (e.g., xiphi-umbilical distance (Xi)), is also determined from measured changes in voltage between transmission coil **22a** and receive coil **24b**.

[0101] As indicated above, in some embodiments of the invention, more than two pairs of electromagnetic coils can be employed. As set forth in U.S. Patent Application No. 61/275,575, filed Sep. 1, 2009, and co-pending U.S. patent application Ser. No. _____ [Attorney Docket No. 3483.0250001], filed concurrently herewith, each of which is incorporated by reference herein in its entirety, adding additional electromagnetic coils in anatomically appropriate positions on a subject provides numerous significant advantages over dual-paired coil embodiments. Among the advantages is the provision of additional (and pertinent) data and/or information regarding chest wall movement(s) and the relationship(s) thereof to respiratory activity and respiratory associated events, such as speaking, sneezing, laughing, and coughing.

[0102] Further, the multiple single, cross, and interaction axes of the electromagnetic coil transmissions that result from the additional coils (and placement thereof) provide highly accurate quantification of changes in chest wall volume, and facilitate three-dimensional modeling of chest wall shape and movement of ambulatory subjects, and the evaluation and quantification of ventilatory mechanics, e.g., synchronous and asynchronous movement of the chest wall compartments.

[0103] Referring now to FIGS. 6-17, the multiple-paired coil embodiments of the invention will now be described in detail. It is, however, to be understood that the invention is not limited to the multiple-paired coil embodiments described herein. As will be appreciated by one having ordinary skill in the art, the multiple-paired coil embodiments can include any number of additional electromagnetic coils (e.g., **3**, **4**, **5**, **6**, **7**, **8**, **9**, **10**). For example, in embodiments using three magnetometers, for example, electromagnetic coils, it is understood that the three electromagnetic coils can function as multiple pairs. Specifically, referring to the coils as first, second, and third coils, the first coil can form a pair with the second coil and the first coil can also form a pair with the third coil. In addition, the second coil can also form a pair with the third coil. Thus, a magnetometer system utilizing three electromagnetic coils can be configured to form one, two, or three pairs. Each of the first, second, and third coils can be configured to transmit signals, receive signals, or to both receive and transmit signals. A magnetometer can communicate with a plurality of other magnetometers, and therefore a particular magnetometer can form a part of more than one pair. The position of the additional coils and the function thereof can also be readily modified and/or adapted for a particular application within the scope of the present invention.

[0104] Referring first to FIGS. 6-8, there is shown one embodiment of the multiple-paired coil embodiment of the invention. As illustrated in FIG. 7, the noted embodiment similarly includes electromagnetic coils **22a**, **22b**, **24a**, **24b**. According to the invention, any of the aforementioned dual-paired coil embodiments associated with coils **22a**, **22b**, **24a**, **24b** can be employed with the multiple-paired coil embodiments of the invention.

[0105] As also illustrated in FIGS. 6 and 7, the multiple-paired coil embodiment can further include at least two additional pairs of electromagnetic coils: third transmission coil 32a, third receive coil 32b, fourth transmission coil 34a, and fourth receive coil 34b.

[0106] In some embodiments of the invention, at least one of the two additional receive coils 32b, 34b is a dual function coil and, hence, adapted to receive transmissions from each of transmission coils 32a, 22a, 34a. In some embodiments, each receive coil 32b, 34b is adapted to receive transmissions from each transmission coil 32a, 22a, 34a.

[0107] Referring now to FIGS. 8 and 9, there is shown the position of coils 22a, 22b, 24a, 24b, 32a, 32b, 34a, 34b on a subject or patient 100, in accordance with one embodiment of the invention. As illustrated in FIGS. 8 and 9, first transmission coil 22a is preferably positioned on front 101 of subject 100 proximate the umbilicus of subject 100, and first receive coil 22b is preferably positioned proximate the same axial position, but on back 102 of subject 100. Second receive coil 24b is preferably positioned on front 101 of subject 100 proximate the base of the sternum, and second transmission coil 24a is positioned proximate the same axial position, but on back 102 of subject 100.

[0108] Third transmission coil 32a is preferably positioned on front 101 of subject 100 and axially spaced to the right of first transmission coil 22a. Fourth transmission coil 34a is preferably positioned on front 101 of subject 100 and axially spaced to the left of first transmission coil 22a. In the illustrated embodiment, each transmission coil 32a, 22a, 34a is preferably positioned proximate the same axial plane (denoted "AP₁" in FIGS. 6 and 7).

[0109] Third receive coil 32b is preferably positioned on front 101 of subject 100 and axially spaced to the right of second receive coil 24b. Fourth receive coil 34b is preferably positioned on front 101 of subject 100 and axially spaced to the left of second receive coil 24b. Preferably, each receive coil 32b, 24b, 34b is similarly positioned proximate the same axial plane (denoted "AP₂" in FIGS. 6 and 7).

[0110] As will readily be appreciated by one having ordinary skill in the art, the axial spacing of coils 32a, 32b, 34a, 34b will, in many instances, be dependant on the body size and structure of the subject, e.g., adult, female, male, adolescent. The distance between and amongst the coils can also vary with the degree of measurement precision required or desired.

[0111] Preferably, in the noted embodiment, the axial spacing between coils 32a, 32b, 34a, 34b and coils 22a, 22b, 24a, 24b is substantially equal or uniform.

[0112] As indicated above, a significant advantage of the multiple-paired coil embodiments of the invention is the provision of multiple single, cross, and interaction coil transmission axes that facilitate three-dimensional modeling of chest wall shape and movement of ambulatory subjects, and evaluation and quantification of ventilatory mechanics, e.g., synchronous and asynchronous movement of the chest wall compartments.

[0113] A further significant advantage of the multiple-paired coil embodiments of the invention is that real-time, three-dimensional models of the chest wall can be created by simultaneous monitoring of the chest wall with the multiple-paired coils of the invention.

[0114] Another advantage is that with sufficiently tight tolerances on the coil field strength(s), volume calibration would

not be necessary. Measurement precision would, thus, be determined by the geometrical void spaces between the various coil pairs.

[0115] Referring now to FIGS. 10-12, there are shown several schematic illustrations of coil transmission axes provided by three multiple-paired coil embodiments of the invention. Referring first to FIG. 10, there is shown one embodiment, wherein each receive coil 32b, 24b, 34b, 22b is a single function coil. Receive coil 32b is adapted to receive a transmission T₃₂ from transmission coil 32a. Receive coil 24b is adapted to receive a transmission T₂₂ from transmission coil 22a. Receive coil 34b is adapted to receive a transmission T₃₄ from transmission coil 34a. Receive coil 22b is adapted to receive a transmission T₂₄ from transmission coil 24a.

[0116] Referring now to FIG. 12, there is shown another embodiment, wherein receive coil 24b is a dual function coil. Receive coil 32b is adapted to receive transmission T₃₂ from transmission coil 32a, receive coil 34b is adapted to receive transmission T₃₄ from transmission coil 34a, and receive coil 22b is adapted to receive transmission T₂₄ from transmission coil 24a. Receive coil 24b is, however, adapted to receive transmission T₃₂ from transmission coil 32a, transmission T₂₂ from transmission coil 22a, transmission T₃₄ from transmission coil 34a, and transmission T₂₄ from transmission coil 24a.

[0117] In a further embodiment, illustrated in FIG. 11, each receive coil 32b, 24b, 34b, 22b is a dual function coil. As illustrated in FIG. 11, receive coil 32b is adapted to receive transmission T₃₂ from transmission coil 32a, transmission T₂₂ from transmission coil 22a, transmission T₃₄ from transmission coil 34a, and transmission T₂₄ from transmission coil 24a. Receive coils 24b, 34b, and 22b are also adapted to receive transmission T₃₂ from transmission coil 32a, transmission T₂₂ from transmission coil 22a, transmission T₃₄ from transmission coil 34a, and transmission T₂₄ from transmission coil 24a.

[0118] The noted multiple-paired coil embodiments significantly enhance the available data and information associated with chest wall movement and, hence, respiratory activity and respiratory associated events. The additional data and information also facilitates the evaluation and quantification of ventilatory mechanics, e.g., synchronous and asynchronous movement of the chest wall compartments.

[0119] The supplemental coil transmissions (or signals) can also be readily employed to reduce or eliminate the frequency and impact of magnetic field interference and artifacts, which are commonly encountered in electromagnetic coil systems.

[0120] As indicated above, the multiple-paired coil embodiments of the invention are not limited to the embodiment described above, wherein two additional pairs of electromagnetic coils are uniformly positioned on the front of a subject. Referring now to FIGS. 13-17, there are shown additional multiple-paired coil embodiments of the invention.

[0121] Referring first to FIG. 13, there is shown a multiple-paired coil embodiment, wherein the two additional coil pairs 32a, 32b, and 34a, 34b are non-uniformly positioned on front 101 of subject 100. As indicated, the additional coil pairs can be positioned at any appropriate (or desired) positions on the torso of subject 100.

[0122] Additional paired coils (e.g., transmission coil 36a paired with receive coil 36b, and transmission coil 38a paired with receive coil 38b) can also be positioned on back 102 of subject 100, as illustrated in FIG. 14. Coils 36a, 36b, 38a, 38b

can be positioned uniformly, as shown in FIG. 14, or non-uniformly, as illustrated in FIG. 15.

[0123] Referring now to FIGS. 16-17, there is shown another multiple-paired coil embodiment, wherein additional paired coils are positioned on the torso of subject 100. As illustrated in FIG. 16, additional paired coils (e.g., transmission coil 33a paired with receive coil 33b, and transmission coil 35a paired with receive coil 35b) can be positioned on front 101 of subject 100. In the noted embodiment, transmission coil 33a is preferably positioned above and between transmission coils 32a and 22a, and transmission coil 35a is preferably positioned above and between transmission coils 22a and 34a. Receive coil 33b is preferably positioned above and between receive coils 32b and 24b, and receive coil 35b is preferably positioned above and between receive coils 24b and 34b.

[0124] As illustrated in FIGS. 16 and 17, additional paired coils (e.g., transmission coil 37a paired with receive coil 37b, and transmission coil 39a paired with receive coil 39b) can be also positioned on opposite sides of the subject 100.

[0125] Additionally, the transmission coils and receive coils disclosed herein need not necessarily be paired one-to-one. For example, a single receive coil may be configured to receive transmissions from multiple transmission coils, and a single transmission coil may be configured to transmit to multiple receive coils.

[0126] As indicated above, the multiple-paired coil embodiments of the invention are not limited to the multiple-paired coil embodiments shown in FIGS. 6-17. It is again emphasized that the multiple-paired coil embodiments can include any number of additional pairs of electromagnetic coils. Further, the position of the additional coils and the function thereof can also be readily modified and/or adapted for a particular application within the scope of the present invention.

[0127] In some embodiments of the invention, the data acquisition subsystem 20 can include means for directly monitoring the orientation and/or movement of subject 100, e.g., spatial parameters. According to the invention, various conventional means can be employed to monitor or measure subject orientation and movement, including optical encoders, proximity and Hall effect switches, laser interferometry, accelerometers, gyroscopes, global positioning systems (GPS), and/or other spatial sensors.

[0128] In one embodiment, the means for directly monitoring the orientation and movement of a subject includes at least one multi-function inertial sensor, e.g., 3-axis accelerometer or 3-axis gyroscope. As is well known in the art, orientation and motion of a subject can be readily determined from the signals or data transmitted by a multi-function accelerometer.

[0129] According to the invention, the accelerometer can be disposed in any anatomically appropriate position on a subject. In one embodiment of the invention, an accelerometer (denoted "AC₁" in FIG. 8) is disposed proximate the base of the subject's sternum.

Control-Data Processing Subsystem

[0130] According to the present invention, control-data processing subsystem 40 can include programs, instructions, and associated algorithms for performing the methods of the invention, including control algorithms and associated parameters to control data acquisition subsystem 20 and, hence, the paired electromagnetic coils, e.g., coils 22a, 22b, 24a, 24b, 32a, 32b, 34a, 34b and the function thereof, and the

transmission and receipt of coil transmissions, e.g., transmissions T₃₂, T₂₂, T₃₄, and T₂₄, as well as data transmission subsystem 50 and data monitoring subsystem 60. Such is discussed in detail below.

[0131] Control-data processing subsystem 40 is further programmed and adapted to retrieve and process coil transmissions or signals from the electromagnetic coils (e.g., coils 22a, 22b, 24a, 24b, 32a, 32b, 34a, 34b) in order to determine physiological information associated with monitored subject 100, to retrieve, process, and interpret additional signals transmitted by additional spatial parameter and physiological sensors (discussed below), and to transmit selective coil data, physiological and spatial parameters, physiological characteristics, and subject information to data monitoring subsystem 60.

[0132] In a preferred embodiment of the invention, control-data processing subsystem 40 further includes at least one "n-degrees-of-freedom" model or algorithm for determining at least one respiratory characteristic (e.g., V_T) from the retrieved coil transmissions or signals (e.g., measured displacements of the rib cage, abdomen, and chest wall).

[0133] In one embodiment, control-data processing subsystem 40 includes one or more "three-degrees-of-freedom" models or algorithms for determining at least one respiratory characteristic (preferably, a plurality of respiratory characteristics) from the retrieved coil transmissions (or signals). Preferred "three-degrees-of-freedom" models (or algorithms) are set forth in co-pending U.S. patent application Ser. No. 12/231,692.

[0134] In some embodiments, control-data processing subsystem 40 is further programmed and adapted to assess physiological characteristics and parameters by comparison with stored physiological benchmarks. Control-data processing subsystem 40 can also be programmed and adapted to assess respiratory and spatial characteristics and parameters by comparison with stored respiratory and spatial benchmarks. Control-data processing subsystem 40 can generate status signals if corresponding characteristics or parameters are present. The benchmarks may indicate, for example, adverse conditions or fitness goals, and the status signals may include warnings or alarms.

[0135] Control-data processing subsystem 40 also preferably includes suitable algorithms that are designed and adapted to determine respiratory characteristics, parameters, and statuses from measured multiple, interactive chest wall displacements. The algorithms are also preferably adapted to discount measured chest wall displacements that are associated with non-respiration movement, e.g., twisting of the torso, to enhance the accuracy of respiratory characteristic (and/or parameter) determinations.

[0136] Control-data processing subsystem 40 additionally preferably includes suitable programs, algorithms, and instructions to generate three-dimensional models of subject's chest wall from the measured multiple, interactive chest wall displacements.

[0137] According to the invention, various programs and methods known in the mathematical arts (e.g., differential geometric methods) can be employed to process the signals (reflecting the chest wall distances and displacement) into a representation of the shape of the torso. Indeed, it is known that providing sufficient distances defined on a two dimensional surface (a metric) permit the shape of the surface to be constructed in a three dimensional space. See, e.g., Badler, et al., "Simulating Humans: Computer Graphics, Animation,

and Control”, (New York: Oxford University Press, 1993) and DeCarlo, et al., “Integrating Anatomy and Physiology for Behavior Modeling”, Medicine Meets Virtual Reality 3 (San Diego, 1995).

[0138] Preferably, in some embodiments of the invention, control-data processing subsystem 40 is further programmed and adapted to determine additional and, in some instances, interrelated anatomical parameters, such as bending, twisting, coughing, etc., from the measured multiple, interactive chest wall displacements. In one embodiment, control-data processing subsystem 40 is programmed and adapted to compare retrieved coil transmissions reflecting measured chest wall displacements with stored selective combinations of coil transmissions and chest wall parameters that are associated therewith (e.g., “normal respiration and bending”, “normal respiration and coughing”).

[0139] By way of example, in one embodiment, a first chest wall parameter (CWP₁) defined as (or reflecting) “normal respiration and twisting of the torso” is stored in control-data processing subsystem 40. The coil transmissions and data associated with the first chest wall parameter (CWP₁) include transmissions T₃₂, T₂₂, T₃₄, and T₂₄ received by receive coil 24b that can represent displacements x, y, and z.

[0140] During monitoring of subject 100, similar coil transmissions may be received by receive coil 24b. Control-data processing subsystem 40 then compares the detected (or retrieved) transmissions to the stored transmissions and chest wall parameters associated therewith to determine (in real-time) the chest wall movement and, hence, respiratory activity based thereon; in this instance “normal respiration and twisting of the torso”.

[0141] In some embodiments, the signals transmitted by the accelerometer (e.g., spatial parameter signals) are employed with the detected coil transmissions to determine and classify chest wall movement and associated respiratory activity of the monitored subject. In the noted embodiments, each stored chest wall parameter also includes spatial parameter signals associated with the chest wall parameter (e.g., normal respiration and twisting of the torso). According to the invention, control-data processing subsystem 40 is adapted to compare retrieved coil transmissions and spatial parameter signals to the stored transmissions and spatial parameter signals, and the chest wall parameters associated therewith, to determine the chest wall movement and, hence, respiratory activity based thereon.

[0142] In some embodiments, the spatial parameter signals are used to generate a spatial model of the subject. The spatial model can be two-dimensional or three-dimensional, and can reflect the real-time orientation and movement of the subject. The spatial model can be displayed to provide the subject or another with a representation of the real-time orientation and movement of the subject.

[0143] In some embodiments of the invention, control-data processing subsystem 40 is programmed and adapted to determine chest wall movement and respiratory activity based on retrieved coil transmissions, spatial parameter signals, and audio signals. In the noted embodiments, data acquisition subsystem 20 can also include an audio sensor, such as, e.g., a microphone, that is disposed in an anatomically appropriate position on a subject, e.g., proximate the throat.

[0144] According to the invention, each stored chest wall parameter also includes at least one audio parameter (e.g., >N db, based on the audio signal) that is associated with the chest wall parameter (e.g., normal respiration and coughing). Suit-

able speech and cough parameters (and threshold determinations) are set forth in U.S. Pat. No. 7,267,652, issued Sep. 11, 2007, which is incorporated by reference herein in its entirety.

[0145] Upon receipt of coil transmissions, spatial parameter signals, and audio signals, control-data processing subsystem 40 compares the retrieved coil transmissions, spatial parameter signals, and audio signals to the stored transmissions, spatial parameter signals, and audio parameters, and the chest wall parameters associated therewith, to determine the chest wall movement and respiratory activity based thereon (e.g., normal respiration and coughing).

[0146] In some embodiments of the invention, control-data processing subsystem 40 is programmed and adapted to determine fitness activity based on retrieved coil transmissions, spatial parameter signals, and audio signals. In the noted embodiments, data acquisition subsystem 20 may also include an audio sensor, such as, for example, a microphone, that is disposed in an anatomically appropriate position on a subject (e.g., proximate the throat).

[0147] Upon receipt of coil transmissions, spatial parameter signals, and audio signals, control-data processing subsystem 40 compares the retrieved coil transmissions, spatial parameter signals, and audio signals to the stored transmissions, spatial parameter signals, and audio parameters, and the chest wall parameters associated therewith, to determine a fitness activity of the subject (e.g., running, jogging, stretching, swimming, performing push-ups, performing sit-ups, performing chin-ups, performing arm curls, playing basketball, playing baseball, or playing soccer).

[0148] Referring first to FIG. 1, there is shown a schematic illustration of one embodiment of a physiology monitoring system according to the present invention. As illustrated in FIG. 1, the physiology monitoring system 10 preferably includes a data acquisition subsystem 20, a control-data processing subsystem 40, a data transmission subsystem 50, a data monitoring subsystem 60, and a power source 70, such as a battery. Control-data processing subsystem 40 is also referred to herein as “processor subsystem,” “processing subsystem,” and “data processing subsystem.” The terms control-data processing subsystem, processor subsystem, processing subsystem, and data processing subsystem are used interchangeably in the present application.

Data Monitoring Subsystem

[0149] According to embodiments of the invention, data monitoring subsystem 60 is designed and adapted to receive and, in some embodiments, to selectively monitor coil transmissions or signals (e.g., transmissions T₃₂, T₂₂, T₃₄, and T₂₄) and to display parameters associated therewith (e.g., displacement(s) along a selective axis), and/or a chest wall parameter (e.g., CWP₁), and/or a respiratory characteristic (e.g., V_T) or event.

[0150] Data monitoring subsystem 60 is further preferably designed and adapted to display selective subject parameters, characteristics, information, and warnings or alarms. Data monitoring subsystem 60 can also be adapted to display data or broadcast data aurally. The aurally presented data can be voice messages, music, or other noises signifying an event. Data monitoring subsystem 60 can be adapted to allow headphones or speakers to connect to the data monitoring subsystem, either wireless or wired, to broadcast the aural data. Data monitoring subsystem 60 can be adapted to include a display, or to allow a display to connect to the data monitoring subsystem, to display the data. Such display can include, for

example, a liquid crystal display (LCD), a plasma display, a cathode ray tube (CRT) display, a light emitting diode (LED) display, or an organic light emitting diode (OLED) display.

[0151] In some embodiments of the invention, data monitoring subsystem **60** is also adapted to receive and, in some embodiments, selectively monitor spatial parameter signals and signals transmitted by additional anatomical and physiological sensors (e.g., signals indicating skin temperature, or SpO₂) and to display parameters and information associated therewith. The parameters can be associated with an athlete's physical activity. Physical or anatomical parameters measured and/or calculated may include, for example, time, location, distance, speed, pace, stride count, stride length, stride rate, and/or elevation. Physiological parameters measured and/or calculated may include, for example, heart rate, respiration rate, blood oxygen level, blood flow, hydration status, calories burned, muscle fatigue, and/or body temperature. In an embodiment, performance parameters may also include mental or emotional parameters such as, for example, stress level or motivation level. Mental and emotional parameters may be measured and/or calculated directly or indirectly either through posing questions to the athlete or by measuring things such as, for example, trunk angle or foot strike characteristics while running.

[0152] In some embodiments of the invention, data monitoring subsystem **60** includes a local electronic module or local data unit (LDU). The term "local" as used in connection with an LDU is intended to mean that the LDU is disposed close to the electromagnetic coils, such as on or in a wearable garment containing the coils (discussed in detail below).

[0153] In some embodiments of the invention, the LDU is preferably adapted to receive and monitor coil transmissions (or signals), to preprocess the coil transmissions, to store the coil transmissions and related data, and to display selective data, parameters, physiological characteristics, and subject information.

[0154] In some embodiments, the LDU is also adapted to receive and monitor the spatial parameter transmissions (or signals) and additional signals transmitted by additional anatomical and physiological sensors (if employed), to preprocess the signals, to store the signals and related data, and to display selective data, physiological and spatial parameters, physiological characteristics, and subject information via a variety of media, such as a personal digital assistant (PDA), a mobile phone, and/or a computer monitor, etc.

[0155] In some embodiments, the LDU includes a remote monitor or monitoring facility. In these embodiments, the LDU is further adapted to transmit selective coil and sensor data, physiological parameters and characteristics, spatial parameters, and subject information to the remote monitor or facility.

[0156] In some embodiments of the invention, the LDU includes the features and functions of control-data processing subsystem **40** (e.g., an integral control-processing/monitoring subsystem) and, hence, is also adapted to control data acquisition subsystem **20**. The LDU is thus adapted to control the paired coils that are employed, to determine selective physiological characteristics and parameters, to assess physiological characteristics and parameters for adverse conditions, and to generate warnings or alarms if adverse characteristics or parameters are present.

[0157] Suitable LDUs are described in co-pending International Application No. PCT/US2005/021433 (Pub. No. WO

2006/009830 A2), published Jan. 26, 2006, which is incorporated by reference herein in its entirety.

[0158] In some embodiments of the invention, monitoring subsystem **60** includes a separate, remote monitor or monitoring facility. According to embodiments of the invention, the remote monitor or facility is adapted to receive sensor data and information, physiological and spatial parameters, physiological characteristics, and subject information from control-data processing subsystem **40**, and to display the selective coil sensor data and information, physiological and spatial parameters, physiological characteristics, and subject information via a variety of mediums, such as a PDA, computer monitor, etc.

Data Transmission Subsystem

[0159] According to embodiments of the invention, various communication links and protocols can be employed to transmit control signals to data acquisition subsystem **20** and, hence, paired coils, and to transmit coil transmissions (or signals) from the paired coils to control-data processing subsystem **40**. Various communication links and protocols can be employed to transmit data and information, including coil transmissions (or signals) and related parameters, physiological characteristics, spatial parameters, and subject information from control-data processing subsystem **40** to data monitoring subsystem **60**.

[0160] In some embodiments of the invention, the communication link between data acquisition subsystem **20** and control-data processing subsystem **40** includes conductive wires or similar direct communication means. In some embodiments, the communication link between data acquisition subsystem **20** and control-data processing subsystem **40**, as well as between control-data processing subsystem **40** and data monitoring subsystem **60**, is a wireless link.

[0161] According to embodiments of the invention, data transmission subsystem **50** is programmed and adapted to monitor and control the noted communication links and, hence, transmissions by and between data acquisition subsystem **20**, control-data processing subsystem **40**, and data monitoring subsystem **60**.

[0162] In some embodiments of the invention, data acquisition subsystem **20** includes at least one additional physiological sensor (preferably, a plurality of additional physiological sensors) adapted to monitor and record one or more physiological characteristics associated with monitored subject **100**. The physiological sensors can include, without limitation, sensors that are adapted to monitor and record electrical activity of the brain, heart, and other muscles (e.g., EEG, ECG, EMG), pulse rate, blood oxygen saturation level (e.g., SpO₂), skin temperature, and core temperature. Physiological parameters measured and/or calculated may include, for example, heart rate, respiration rate, blood oxygen level, blood flow, hydration status, calories burned, muscle fatigue, and/or body temperature.

[0163] Exemplary physiological sensors are disclosed in U.S. Pat. No. 6,551,252, U.S. Pat. No. 7,267,652, and co-pending U.S. patent application Ser. No. 11/764,527, filed Jun. 18, 2007, each of which is incorporated by reference herein in its entirety.

[0164] According to exemplary embodiments of the invention, the additional sensors can be disposed in a variety of anatomically appropriate positions on a subject. By way of example, a first sensor (e.g., a pulse rate sensor) can be disposed proximate the heart of subject **100** to monitor pulse

rate, and a second sensor (e.g., a microphone) can be disposed proximate the throat of subject **100** to monitor sounds emanating therefrom (e.g., sounds reflecting coughing).

[0165] As indicated above, data acquisition subsystem **20** can also include one or more audio sensors, such as, for example, a microphone, for monitoring sounds generated by a monitored subject, and a speaker to enable two-way communication by and between the monitored subject and a monitoring station or individual.

[0166] According to embodiments of the invention, the paired coils (e.g., electromagnetic coils **22a**, **22b**, **24a**, **24b**, and the aforementioned additional sensors) can be positioned on or proximate a subject by various suitable means. Thus, in some embodiments, the paired coils and/or additional sensors can be directly attached to the subject.

[0167] According to embodiments of the invention, application of the coils and sensors to the body of subject **100** can be achieved via a large range of adhesive techniques providing appropriate strengths and duration of attachment, such as surgical tape and biocompatible adhesives.

[0168] In some embodiments, the paired coils, additional sensors, processing and monitoring systems (e.g., LDUs, if employed) are embedded in or carried by a wearable garment or item that can be comfortably worn by a monitored subject. The associated wiring, cabling, and other power and signal transmission apparatuses and/or systems can also be embedded in the wearable garment.

[0169] According to embodiments of the invention, the wearable monitoring garment can be one or more of a variety of garments, such as a shirt, vest or jacket, belt, cap, patch, and the like. A suitable wearable monitoring garment (a vest) is illustrated and described in co-pending U.S. Patent Application No. 61/275,576, filed Sep. 1, 2009, co-pending U.S. patent application Ser. No. _____ [Attorney Docket No. 3483.0260001], filed concurrently herewith, co-pending U.S. Patent Application No. 61/275,633, filed Sep. 1, 2009, and co-pending U.S. patent application Ser. No. _____ [Attorney Docket No. 3483.0290001], filed concurrently herewith, each of which is incorporated by reference herein in its entirety.

[0170] Additional suitable garments are also disclosed in U.S. Pat. No. 7,267,652, issued Sep. 11, 2007, U.S. Pat. No. 6,551,252, issued Apr. 22, 2003, and U.S. Pat. No. 6,047,203, issued Apr. 4, 2000; each of which is incorporated by reference herein in its entirety.

[0171] As set forth in the noted incorporated references, paired coils or magnetometers, and additional sensors, processing and monitoring systems, LDUs, and other equipment can be arranged in or carried by the wearable monitoring garment, for example, in open or closed pockets, or attached to the garment, as by sewing, gluing, a hook and pile system, e.g., VELCRO® such as that manufactured by Velcro, Inc., and the like.

[0172] The methods and systems of the invention, described above, thus provide numerous significant advantages over conventional physiology monitoring methods and systems. Among the advantages are the provision of methods and systems that provide (i) accurate, real-time determination of a plurality of physiological characteristics, (ii) accurate determination of a plurality of respiratory parameters and characteristics, (iii) accurate assessment of chest wall movement(s) and the relationship(s) thereof to respiratory activity and respiratory associated events, such as speaking and coughing, (iv) real-time determination and characterization

of respiratory events, and (v) real-time determination and characterization of the orientation and movement of a subject.

[0173] A further significant advantage is the provision of additional and pertinent data that facilitates three-dimensional modeling of chest wall shape and movement of ambulatory subjects.

[0174] Another significant advantage of the invention is the provision of systems and associated methods that facilitate evaluation and quantification of ventilatory mechanics (e.g., synchronous and asynchronous movement of the chest wall compartments) and “real-time” three-dimensional modeling of the chest wall. As stated above, this has huge implications in the field of use, as well as applications to specific disease states, such as asthma and COPD, and to acute disease states, such as pneumo-thorax and pulmonary embolism.

[0175] Another advantage of the invention is the provision of systems for accurately determining tidal volume (V_T) and other respiratory characteristics that do not require complex calibration algorithms and associated methods. This similarly has huge implications in the field of use, as well as applications for specific disease states, such as COPD.

[0176] Yet another advantage of the invention is the provision of monitoring systems that allow for measurement of front to back separation between magnetometers as well as vertical separation between different sets of magnetometers. This allows the system to separate a desired signal and information from motion artifacts caused by ambulatory motion.

[0177] Additional advantages and applications of the present invention are apparent with reference to the systems and methods disclosed in U.S. patent application Ser. No. _____ [Attorney Docket No. 3483.0010001], filed concurrently herewith, U.S. patent application Ser. No. _____ [Attorney Docket No. 3483.0250001], filed concurrently herewith, U.S. patent application Ser. No. _____ [Attorney Docket No. 3483.0260001], filed concurrently herewith, U.S. patent application Ser. No. _____ [Attorney Docket No. 3483.0280001], filed concurrently herewith, U.S. patent application Ser. No. _____ [Attorney Docket No. 3483.0290001], filed concurrently herewith, U.S. patent application Ser. No. _____ [Attorney Docket No. 3483.0300001], filed concurrently herewith, and U.S. patent application Ser. No. _____ [Attorney Docket No. 0310001], filed concurrently herewith, each of which is incorporated by reference herein in its entirety.

[0178] Without departing from the spirit and scope of this invention, one of ordinary skill can make various changes and modifications to the invention to adapt it to various usages and conditions. As such, these changes and modifications are properly, equitably, and intended to be, within the full range of equivalence of the invention.

What is claimed is:

1. A fitness monitoring system for monitoring a subject engaged in a physical activity, the system comprising:
 - a sensor subsystem including a first sensor and a second sensor, wherein the first and second sensors are responsive to changes in distance therebetween, wherein the sensor subsystem is configured to generate and transmit a distance signal representative of the distance between the first and second sensors; and
 - a physiological sensor configured to generate and transmit a physiological signal representative of a physiologic parameter of the subject; and
 - a processor subsystem in communication with the sensor subsystem and the physiological sensor, the processor

- subsystem being configured to receive the distance signal and the physiological signal, wherein the processor subsystem is configured to process the physiological signal to obtain a signal that is representative of a physiological parameter of the subject.
2. The fitness monitoring system of claim 1, wherein the first sensor is configured to be secured to the skin of the subject.
 3. The fitness monitoring system of claim 1, wherein the first sensor is adhered to the skin by a biocompatible adhesive.
 4. The fitness monitoring system of claim 3, wherein the second sensor is configured to be secured to the skin of the subject.
 5. The fitness monitoring system of claim 1, wherein the first and second sensors comprise magnetometers.
 6. The fitness monitoring system of claim 1, wherein the physiological sensor is configured to monitor at least one of electrical activity of the brain, electrical activity of the heart, pulse rate, blood oxygen saturation level, skin temperature, EMG, ECG, EEG, and core temperature.
 7. The fitness monitoring system of claim 1, further comprising a monitoring subsystem configured to receive the distance signal, wherein the processor subsystem is configured to process the distance signal to obtain a signal that is representative of a respiratory parameter, and wherein the monitoring subsystem is configured to display a representation of the respiratory parameter.
 8. The fitness monitoring system of claim 7, wherein the processor subsystem comprises a plurality of stored respiratory benchmarks, and wherein the processor subsystem is further configured to compare the respiratory parameter to the plurality of stored respiratory benchmarks and to generate and transmit a status signal in response to a determination that the respiratory parameter corresponds to one of the stored respiratory benchmarks.
 9. The fitness monitoring system of claim 8, wherein the plurality of stored respiratory benchmarks comprise at least one of adverse fitness states and fitness goals.
 10. The fitness monitoring system of claim 1, wherein the processor subsystem is further configured to determine a respiratory activity of the subject based on the distance signal and to generate and transmit a respiratory activity signal representative of the respiratory activity.
 11. The fitness monitoring system of claim 1, wherein the processor subsystem comprises a plurality of stored physiological benchmarks, and wherein the processor subsystem is further configured to compare the physiological parameter to the stored physiological benchmarks and to generate and transmit a status signal in response to a determination that the physiological parameter corresponds to one of the stored physiological benchmarks.
 12. A fitness monitoring system for monitoring a subject engaged in a physical activity, the system comprising:
 - a sensor subsystem comprising:
 - a first sensor and a second sensor, wherein the first and second sensors are responsive to changes in distance therebetween, wherein the sensor subsystem is configured to generate and transmit a distance signal representative of the distance between the first and second sensors; and
 - a third sensor, wherein the third sensor is a spatial sensor configured to detect movement of the subject, wherein the sensor subsystem is configured to generate and transmit a spatial signal representative of a movement of a body part of the subject; and
 - a processor subsystem in communication with the sensor subsystem, the processor subsystem being configured to receive the distance signal and the spatial signal.
 13. The fitness monitoring system of claim 12, wherein the first and second sensors comprise magnetometers.
 14. The fitness monitoring system of claim 12, wherein the spatial sensor is configured to detect the orientation of a body part of the subject, and wherein the spatial signal includes representative of the orientation of the body part.
 15. The fitness monitoring system of claim 12, wherein the first and second sensors are configured to be secured directly to the subject's skin.
 16. The fitness monitoring system of claim 15, wherein the first and second sensors are configured to be secured to the skin by surgical tape.
 17. The fitness monitoring system of claim 15, wherein the first and second sensors are configured to be secured to the skin by a biocompatible adhesive.
 18. The fitness monitoring system of claim 12, wherein the sensor subsystem comprises a plurality of sensors responsive to changes in distance therebetween.
 19. The fitness monitoring system of claim 18 wherein the sensor subsystem is configured to generate and transmit a plurality of distance signals, and wherein each distance signal is representative of a distance between at least two magnetometers.
 20. The fitness monitoring system of claim 12, wherein the spatial sensor includes at least one of an optical encoder, a proximity switch, a Hall effect switch, a laser interferometry system, an inertial sensor, and a global positioning system.
 21. The fitness monitoring system of claim 12, further comprising a monitoring subsystem, wherein the processor subsystem is configured to process the distance signal to obtain a signal that is representative of a respiratory parameter, and wherein the monitoring subsystem is configured to display a representation of the respiratory parameter.
 22. The fitness monitoring system of claim 21, wherein the processor subsystem comprises a plurality of stored respiratory benchmarks, and wherein the processor subsystem is further configured to compare the respiratory parameter to the plurality of stored respiratory benchmarks and to generate and transmit a status signal in response to a determination that the distance signal corresponds to one of the stored respiratory benchmarks.
 23. The fitness monitoring system of claim 22, wherein the plurality of stored respiratory benchmarks comprises at least one of adverse fitness states and fitness goals.
 24. The fitness monitoring system of claim 12, wherein the processor subsystem is further configured to determine a respiratory activity of the subject based on the distance signal, and to generate and transmit a respiratory activity signal representative of the respiratory activity.
 25. The fitness monitoring system of claim 12, wherein the processor subsystem comprises a plurality of stored spatial benchmarks, and wherein the processor subsystem is further configured to compare the spatial signal to the plurality of stored spatial benchmarks, and to generate and transmit a status signal in response to a determination that the spatial signal corresponds to one of the stored spatial benchmarks.
 26. The fitness monitoring system of claim 25, wherein the plurality of stored spatial benchmarks comprises at least one of adverse fitness states and fitness goals.

27. The fitness monitoring system of claim **12**, wherein the processor subsystem is further configured to determine a fitness activity of the subject based on the spatial signal, and to generate and transmit a fitness activity signal representative of the fitness activity.

28. The fitness monitoring system of claim **14**, wherein the processor subsystem is further configured to generate a three-dimensional spatial model of the orientation and movement of the subject based on the spatial signal.

29. A method for monitoring a subject engaged in a physical activity, the method comprising:

generating a distance signal representative of the distance between a first sensor and a second sensor and transmitting the respiratory signal to a processor subsystem, wherein the respiratory signal is generated by a sensor subsystem, wherein the first and second sensors are responsive to changes in distance therebetween;

generating a spatial signal representative of an orientation of a body part of the subject and transmitting the spatial signal to the processor subsystem; and

receiving the respiratory signal and the spatial signal at the processor subsystem.

30. The method of claim **29**, further comprising generating a physiological signal representative of a physiological parameter of the subject and transmitting the physiological signal to a processor subsystem;

31. The method of claim **29**, further comprising displaying a representation of the respiratory parameter.

32. The method of claim **29**, further comprising:

processing the respiratory signal to obtain a signal which is representative of a respiratory parameter of the subject, and comparing the respiratory parameter to a plurality of stored respiratory benchmarks; and

generating and transmitting a status signal in response to a determination that the respiratory parameter corresponds to one of the stored respiratory benchmarks.

33. The method of claim **32**, wherein the plurality of stored respiratory benchmarks comprise at least one of adverse fitness states and fitness goals.

34. The method of claim **29**, further comprising: determining a respiratory activity of the subject based on the respiratory signal; and generating and transmitting a respiratory activity signal representative of the respiratory activity.

35. The method of claim **29**, further comprising: comparing the orientation of the body part to a plurality of stored spatial benchmarks; and generating and transmitting a status signal in response to a determination that the orientation of the body part corresponds to one of the stored spatial benchmarks.

36. The method of claim **35**, wherein the plurality of stored spatial benchmarks comprises at least one of adverse fitness states and fitness goals.

37. The method of claim **29**, further comprising: determining at least one fitness activity of the subject based on the spatial signal; and generating and transmitting a spatial activity signal representative of the spatial activity.

38. The method of claim **29**, further comprising generating a three-dimensional spatial model of the orientation and movement of the subject based on the spatial signal.

39. The method of claim **30**, further comprising: comparing the physiological signal to a plurality of stored physiological benchmarks; and generating and transmitting a status signal in response to a determination that the physiological signal corresponds to one of the stored physiological benchmarks.

40. The method of claim **39**, wherein the plurality of stored physiological benchmarks comprises at least one of adverse fitness states and fitness goals.

41. The method of claim **29**, wherein the spatial signal further represents movement of a body part of the subject.

* * * * *

专利名称(译)	一种主体生理和运动表现特征监测的方法和系统		
公开(公告)号	US20110054272A1	公开(公告)日	2011-03-03
申请号	US12/869585	申请日	2010-08-26
[标]申请(专利权)人(译)	阿迪达斯股份公司		
申请(专利权)人(译)	阿迪达斯, 体育世界		
当前申请(专利权)人(译)	阿迪达斯, 体育世界		
[标]发明人	DERCHAK P ALEXANDER		
发明人	DERCHAK, P. ALEXANDER		
IPC分类号	A61B5/00 A61B5/04		
CPC分类号	A61B5/0002 A61B5/02055 A61B5/024 A61B5/0402 A61B5/0488 G06F19/3481 A61B5/11 A61B5/1135 A61B5/14551 A61B5/411 A61B2562/0219 A61B5/0816 A61B5/01 A61B5/0476 A61B5/1118 A61B5/14542 A61B5/742 A61B2503/10 A61B2562/0223 A63B24/0003 G06F19/34		
优先权	61/275586 2009-09-01 US		
其他公开文献	US9326705		
外部链接	Espacenet USPTO		

摘要(译)

本发明涉及用于监测受试者特征的系统和方法。根据本发明显例性实施例的系统包括传感器子系统，该传感器子系统包括至少一个呼吸传感器，该呼吸传感器靠近受试者设置并且被配置为检测受试者的呼吸特征，其中传感器子系统被配置为产生并传输至少一个呼吸表示呼吸特征的信号，和至少一个设置在受试者附近并配置成检测受试者的生理特征的生理传感器，其中传感器子系统配置成产生和传输表示生理特征的至少一个生理信号，和处理子系统与传感器子系统通信，处理子系统被配置为接收至少一个呼吸信号和至少一个生理信号中的至少一个。

