



US 20050076905A1

(19) **United States**

(12) **Patent Application Publication**
Stahmann et al.

(10) **Pub. No.: US 2005/0076905 A1**

(43) **Pub. Date: Apr. 14, 2005**

(54) **USE OF EXTERNAL RESPIRATORY
THERAPY DEVICE TO DETECT CARDIAC
ELECTRICAL ACTIVITY**

Related U.S. Application Data

(60) Provisional application No. 60/504,356, filed on Sep. 18, 2003.

(76) Inventors: **Jeffrey E. Stahmann**, Ramsey, MN
(US); **Jesse W. Hartley**, Lino Lakes,
MN (US); **Kent Lee**, Shoreview, MN
(US); **Quan Ni**, Shoreview, MN (US)

Publication Classification

(51) **Int. Cl.⁷** **A61M 15/00**

(52) **U.S. Cl.** **128/203.14**

Correspondence Address:
Crawford Maunu PLLC
Suite 390
1270 Northland Drive
St. Paul, MN 55120 (US)

(57) **ABSTRACT**

Methods and systems provide an integrated approach to respiratory and cardiac monitoring, diagnosis and/or therapy. A medical system includes one or more cardiac electrodes coupled to an external respiratory therapy device. The cardiac electrodes sense cardiac electrical activity that is used to generate an electrocardiogram (ECG) signal. Cardiac events, such as arrhythmia, myocardial infarction and/or ischemia, may be detected based on the sensed cardiac electrical activity.

(21) Appl. No.: **10/922,351**

(22) Filed: **Aug. 19, 2004**

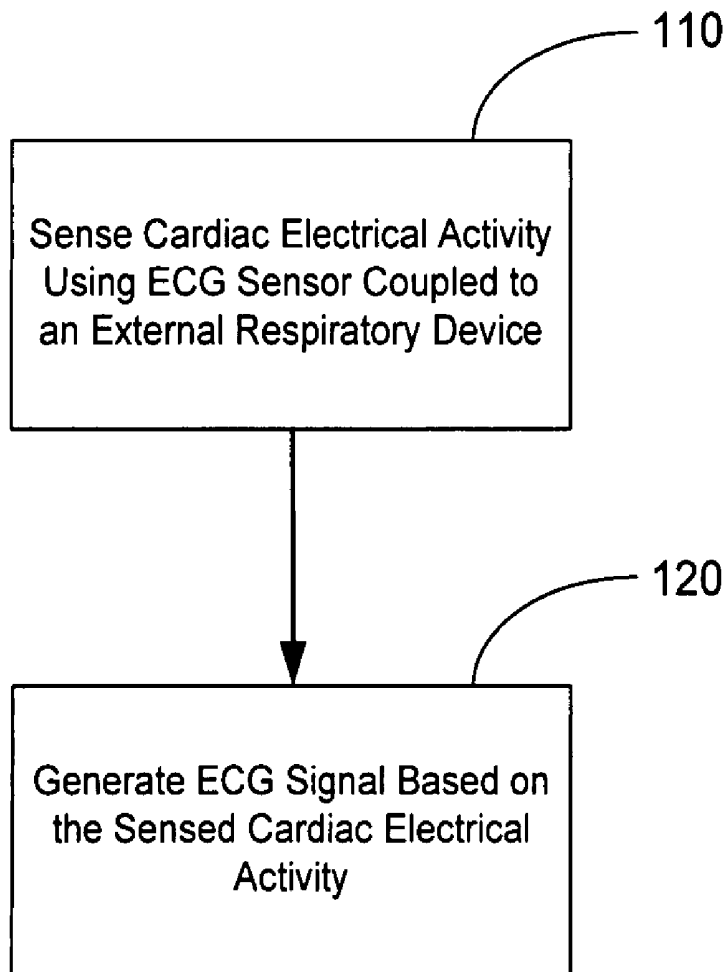

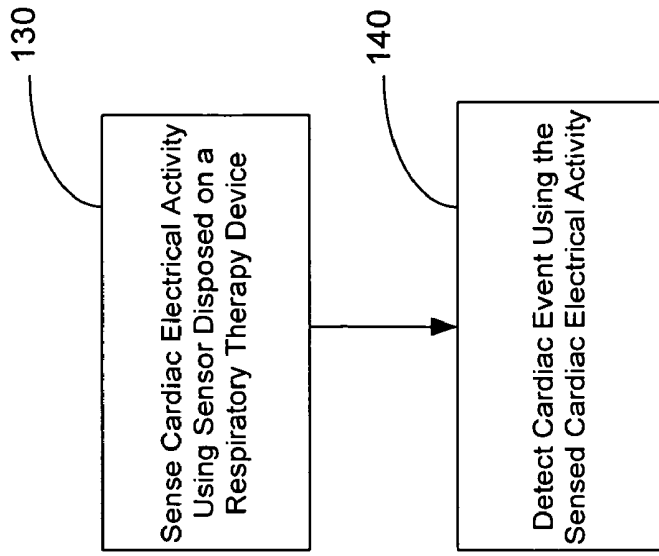

Figure 1B

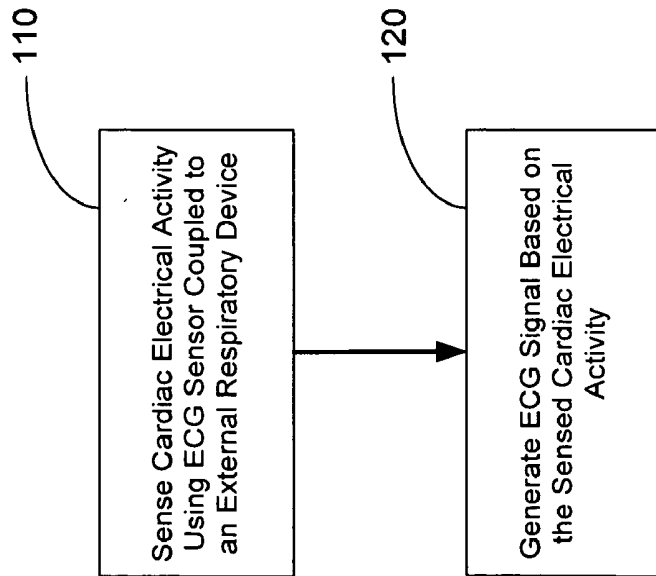

Figure 1A

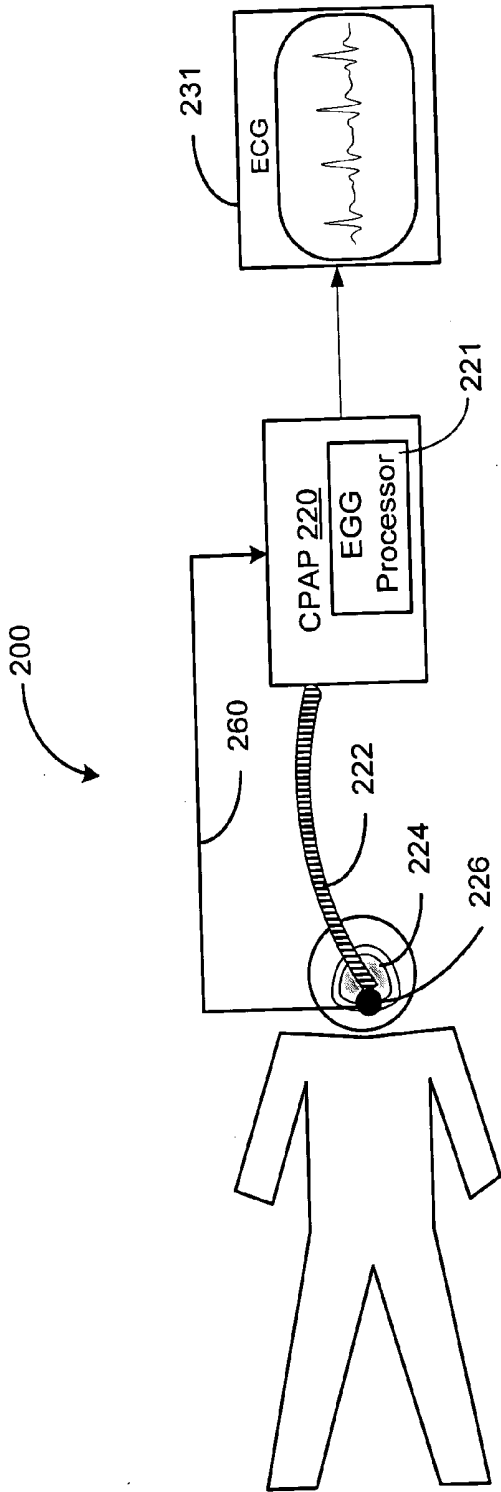

Figure 2A

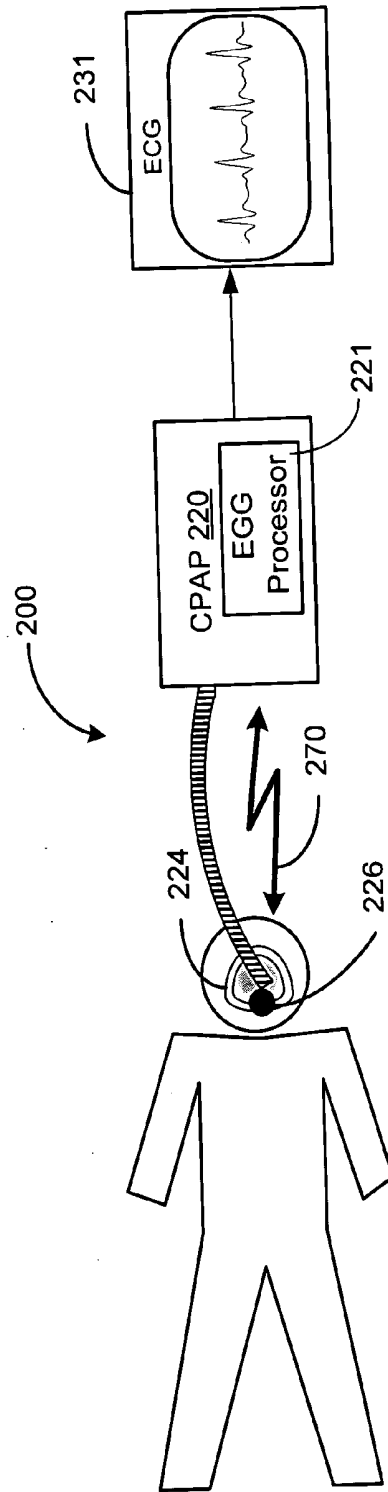

Figure 2B

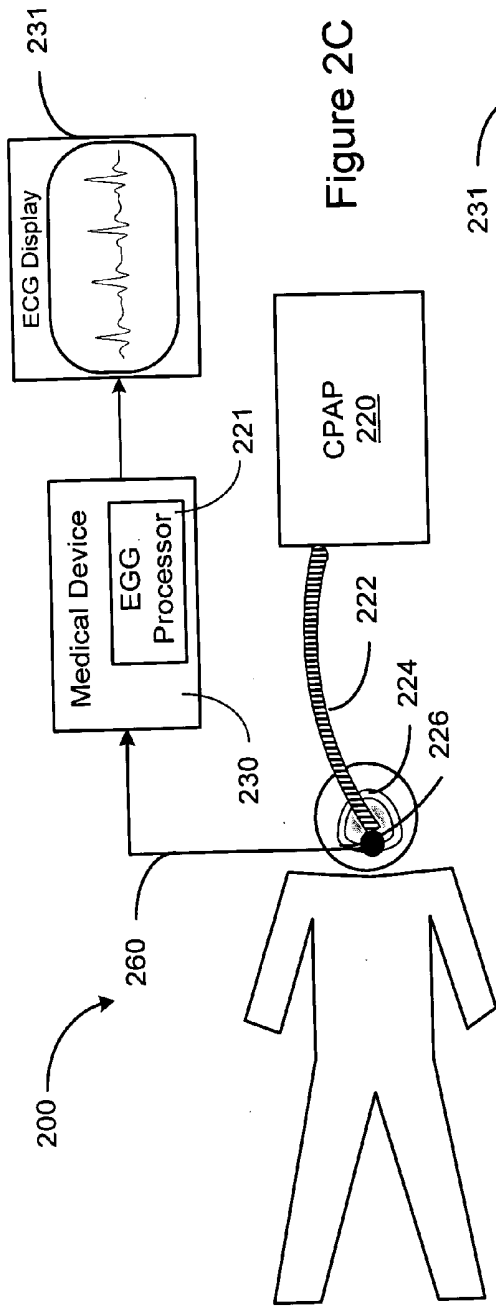

Figure 2C

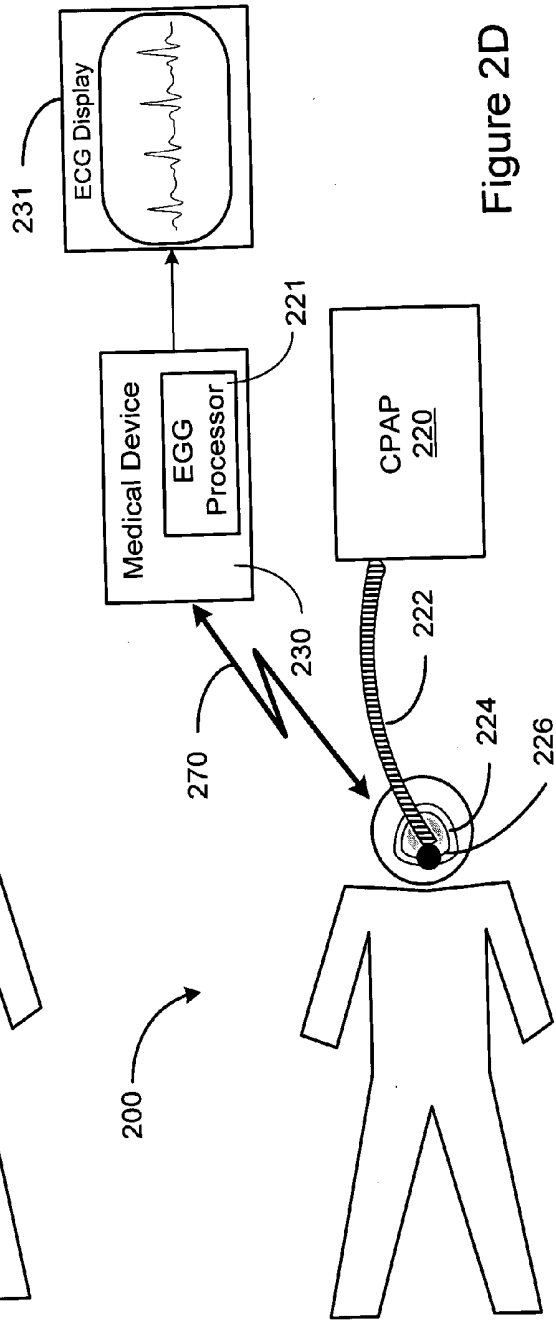

Figure 2D

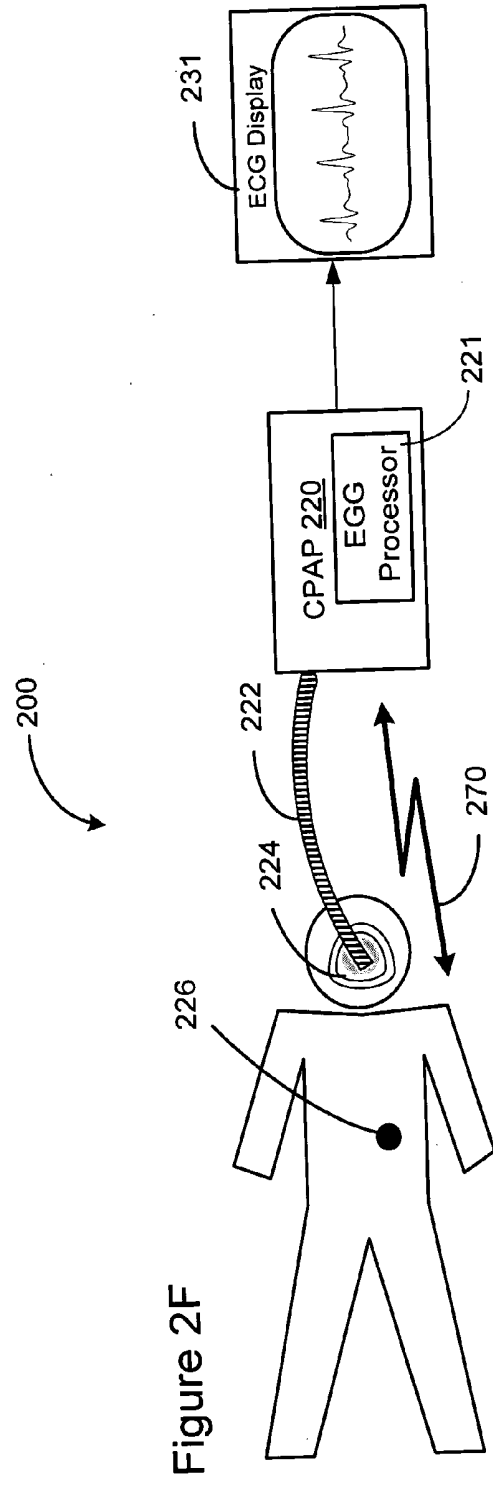
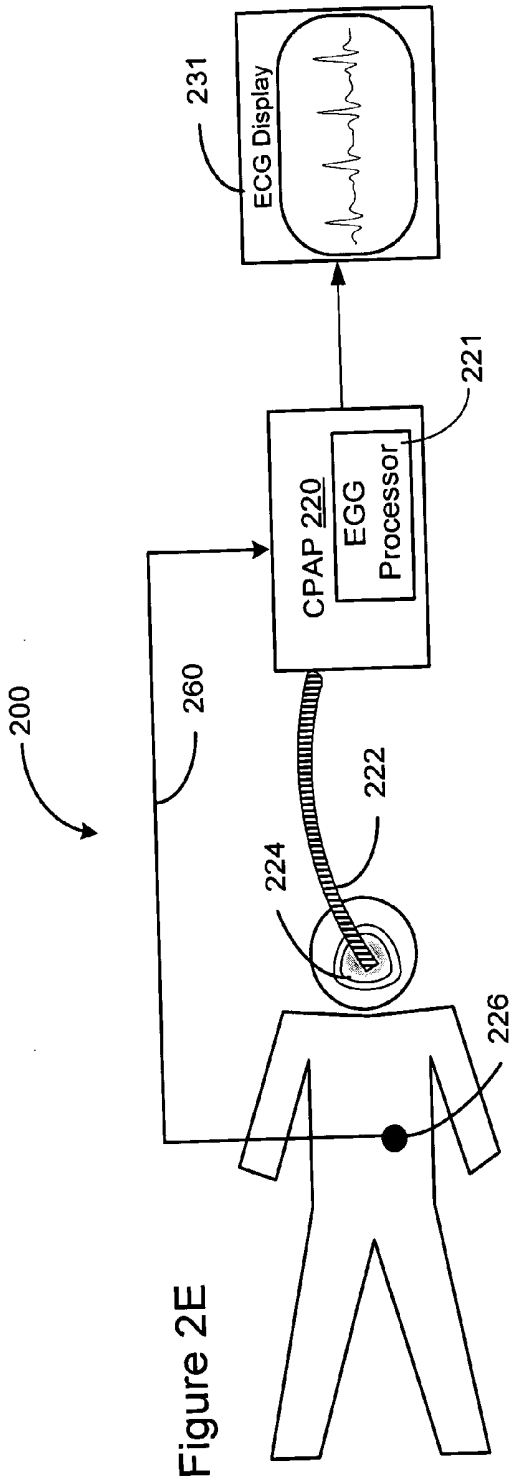

Figure 2G

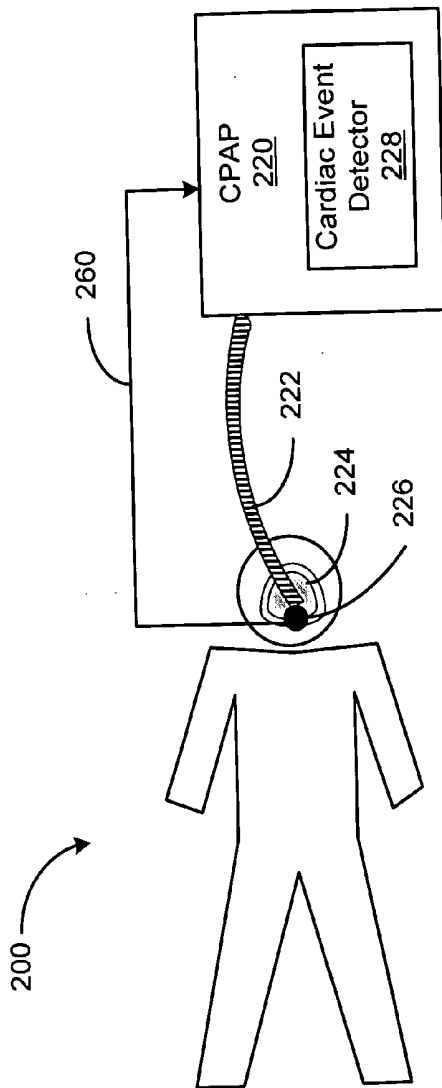

Figure 2H

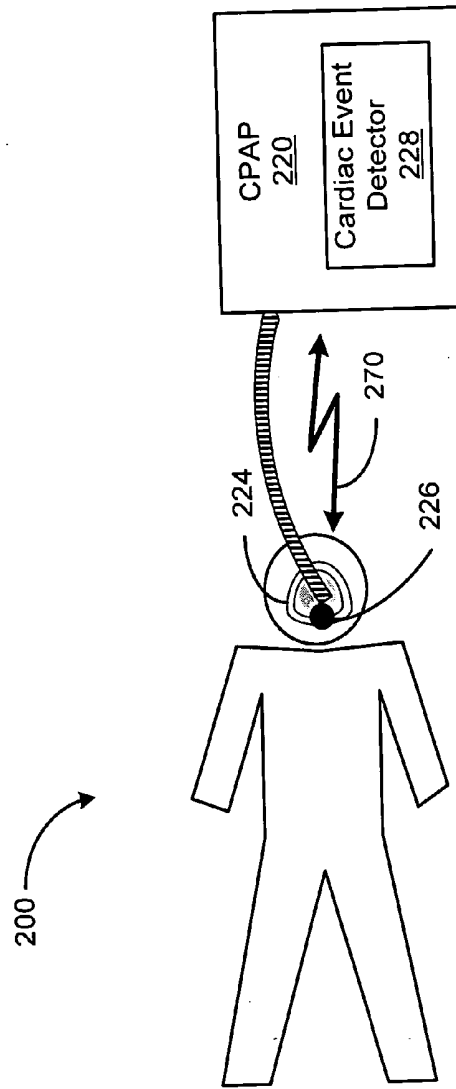

Figure 2I

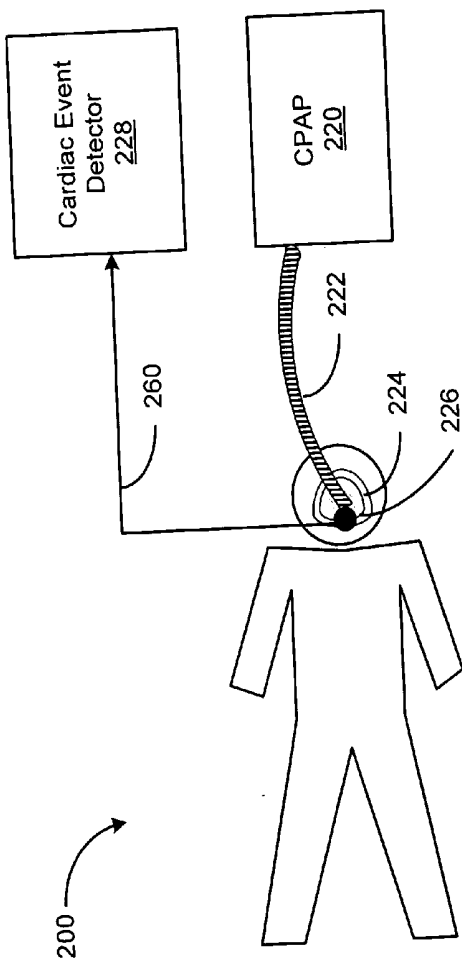
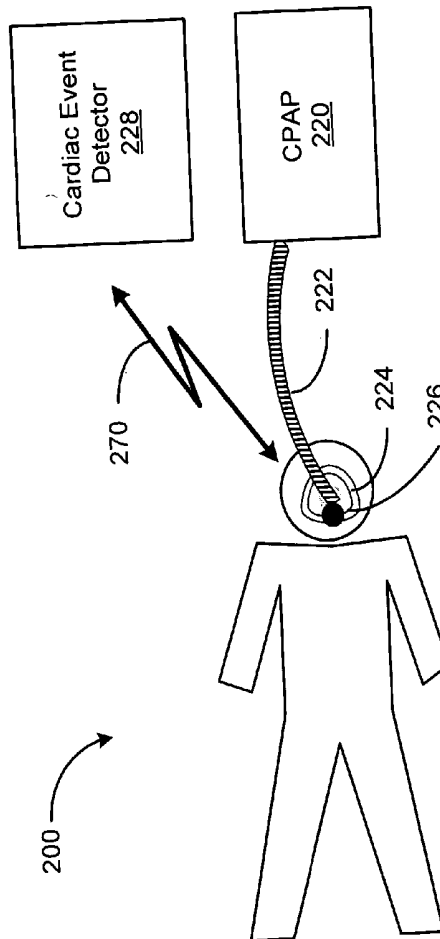

Figure 2J



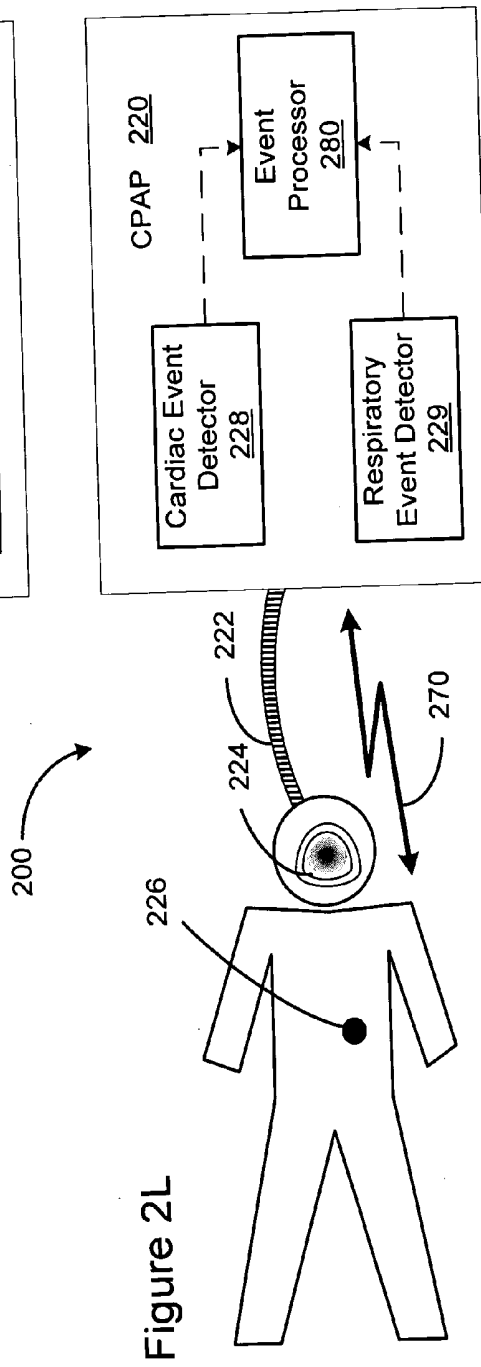
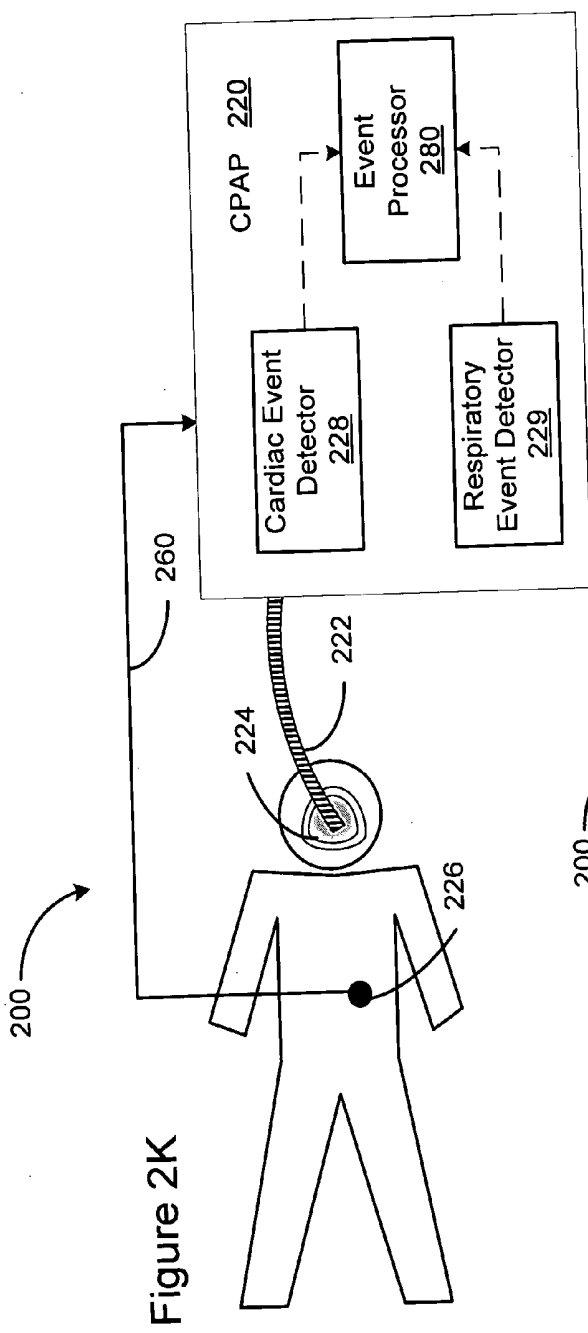

Figure 2M

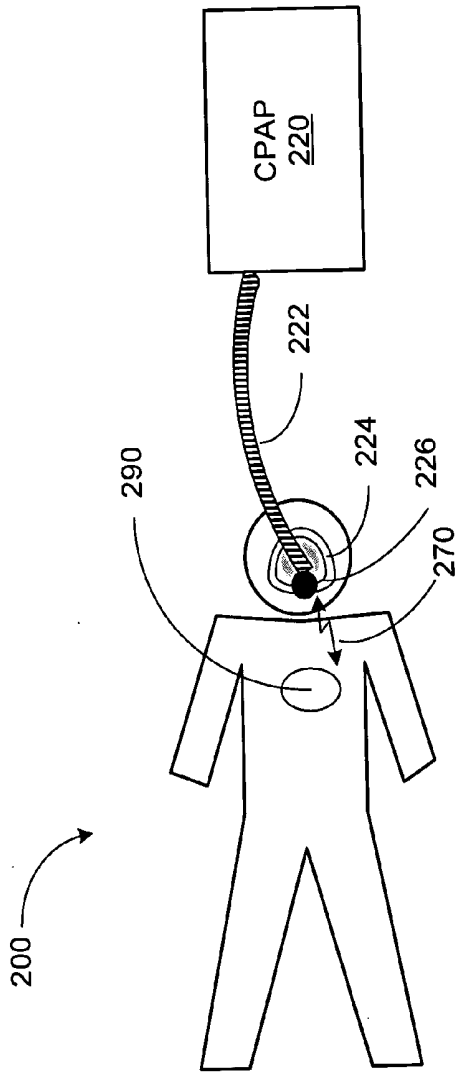
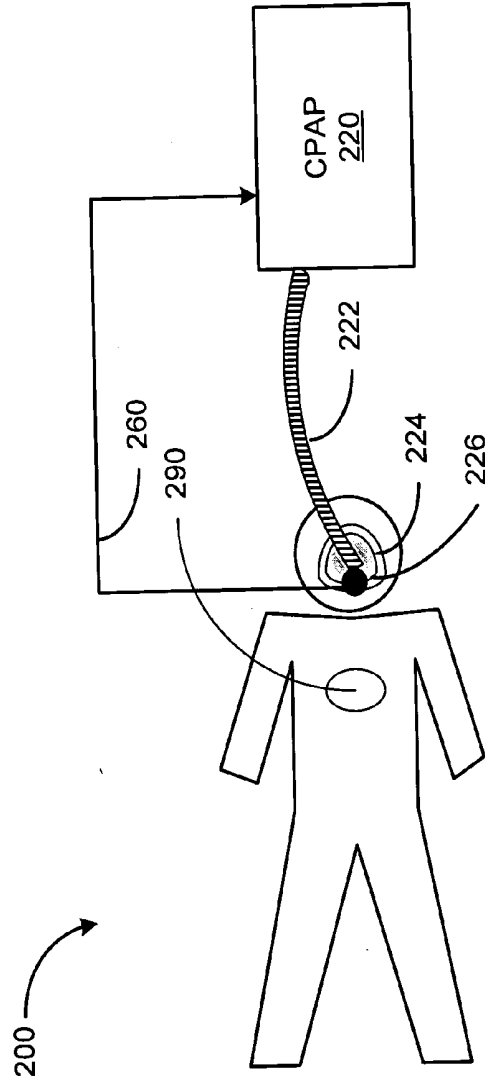

Figure 2N



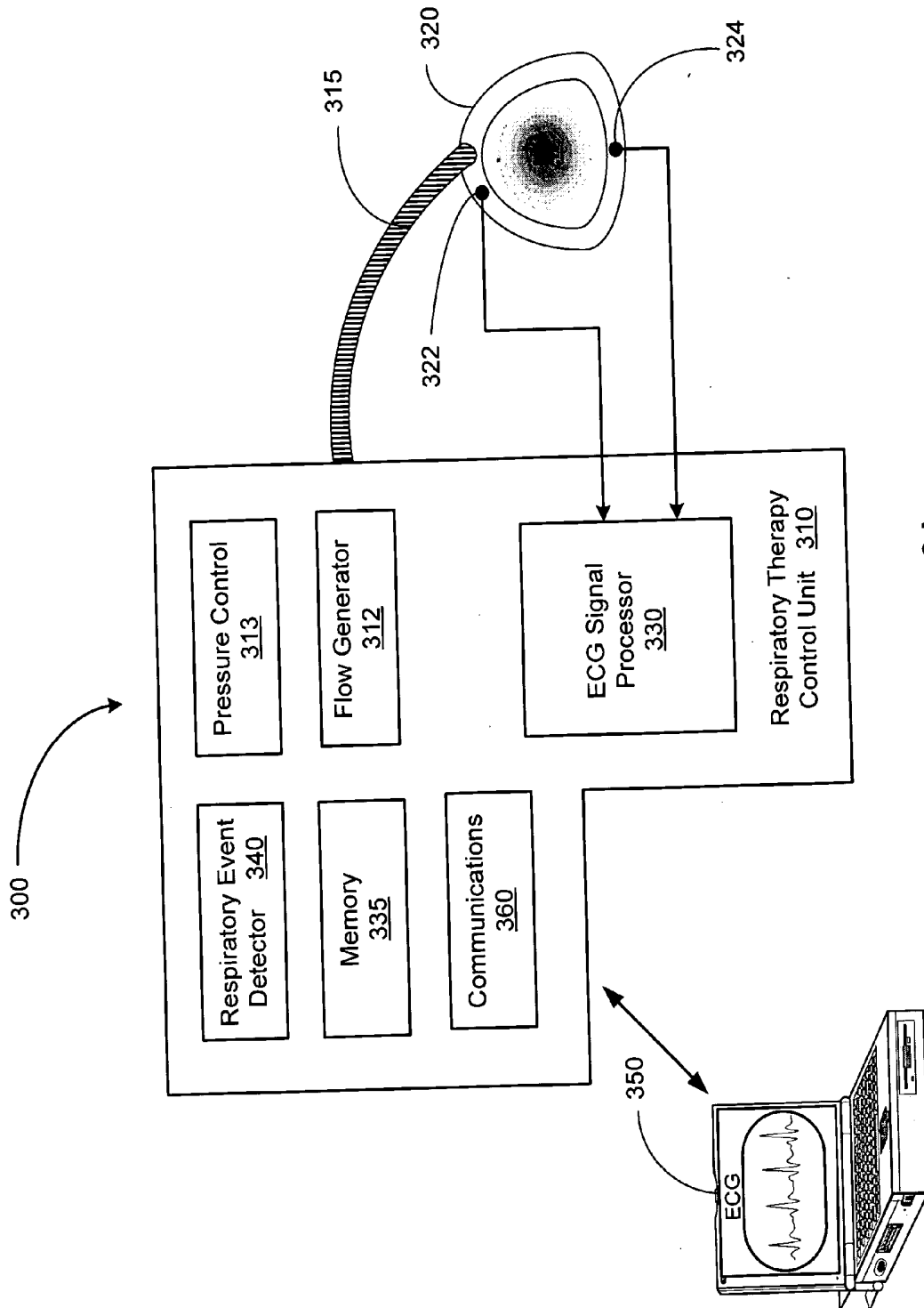

Figure 3A

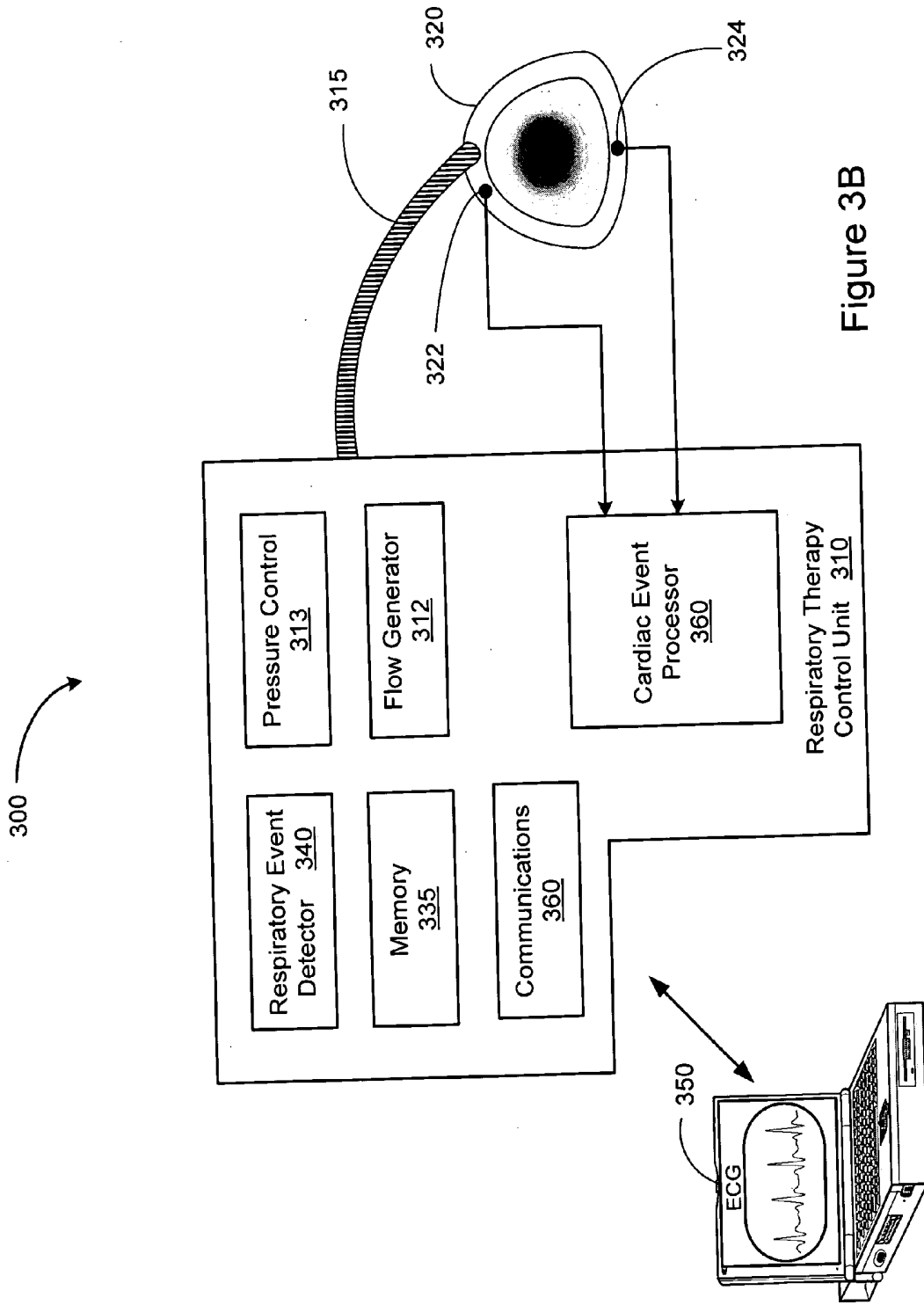

Figure 3B

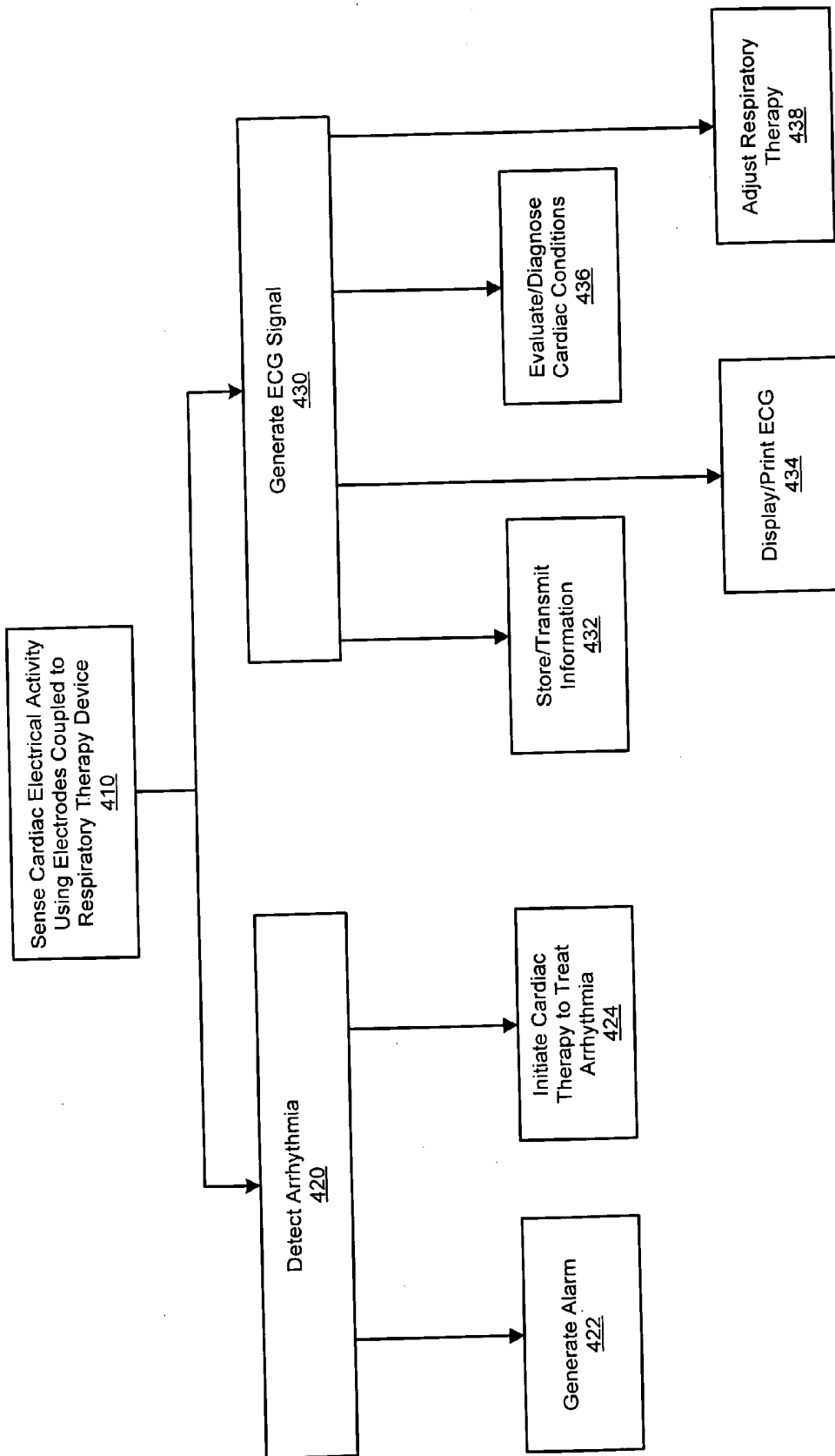

Figure 4

USE OF EXTERNAL RESPIRATORY THERAPY DEVICE TO DETECT CARDIAC ELECTRICAL ACTIVITY

RELATED PATENT DOCUMENTS

[0001] This application claims the benefit of Provisional Patent Application Serial No. 60/504,356, filed on Sep. 18, 2003, to which priority is claimed pursuant to 35 U.S.C. §119(e) and which is hereby incorporated herein by reference.

FIELD OF THE INVENTION

[0002] The present invention relates generally to methods and systems for detecting cardiac electrical activity using electrodes coupled to an external respiratory therapy device.

BACKGROUND OF THE INVENTION

[0003] The human body functions through a number of interdependent physiological systems controlled through various mechanical, electrical, and chemical processes. The metabolic state of the body is constantly changing. For example, as exercise level increases, the body consumes more oxygen and gives off more carbon dioxide. The cardiac and pulmonary systems maintain appropriate blood gas levels by making adjustments that bring more oxygen into the system and dispel more carbon dioxide. The cardiovascular system transports blood gases to and from the body tissues. The respiration system, through the breathing mechanism, performs the function of exchanging these gases with the external environment. Together, the cardiac and respiration systems form a larger anatomical and functional unit denoted the cardiopulmonary system.

[0004] Various disorders may affect the cardiovascular, respiratory, and other physiological systems. For example, heart failure is a clinical syndrome that impacts a number of physiological processes. Heart failure is an abnormality of cardiac function that causes cardiac output to fall below a level adequate to meet the metabolic demand of peripheral tissues. Heart failure is usually referred to as congestive heart failure (CHF) due to the accompanying venous and pulmonary congestion. Congestive heart failure may have a variety of underlying causes, including ischemic heart disease (coronary artery disease), hypertension (high blood pressure), and diabetes, among others.

[0005] Abnormal breathing patterns often occur in conjunction with congestive heart failure (CHF). A form of disordered breathing is known as periodic breathing (PB). In particular, a form of periodic breathing known as Cheyne-Stokes respiration (CSR) is commonly associated with poor prognosis when diagnosing CHF patients. Some studies have suggested that disordered breathing is related to a higher incidence of cardiac arrhythmia.

[0006] External breathing therapy may be prescribed for patients suffering from various types of breathing dysfunction. For example, positive airway pressure devices are often used to treat disordered breathing such as CSR and other types of disordered breathing. The positive airway pressure provided by the device acts as a pneumatic splint keeping the patient's airway open and reducing the severity and/or number of occurrences of disordered breathing events due to airway obstruction.

[0007] Effective approaches to monitoring and evaluating cardiac conditions in patients receiving therapy for respiratory disorders is desirable. The present invention fulfills these and other needs, and addresses other deficiencies of prior art implementations and techniques.

SUMMARY OF THE INVENTION

[0008] Various embodiments are directed to methods and systems for detecting cardiac electrical activity using an external respiratory therapy device. In accordance with one embodiment, a medical system includes one or more cardiac electrodes configured to sense cardiac electrical activity. The cardiac electrodes are coupled to an external respiratory therapy device. The cardiac electrical activity is used to generate an electrocardiogram (ECG) signal.

[0009] In accordance with another embodiment of the invention, a system includes sensors coupled to an external respiratory therapy device. The sensors are configured to sense electrical activity of a heart. A cardiac event detector is coupled to the one or more sensors and is configured to detect one or more cardiac events based on the sensed cardiac electrical activity.

[0010] Another embodiment of the invention involves a method for generating an electrocardiogram (ECG) signal. Cardiac electrical activity is sensed using one or more cardiac electrodes coupled to an external respiratory therapy device. The ECG signal is generated based on the sensed cardiac electrical activity.

[0011] A further embodiment involves detecting cardiac events. The method includes sensing cardiac electrical activity using one or more cardiac electrodes coupled to an external respiratory therapy device. The cardiac events are detected based on the sensed cardiac electrical activity.

[0012] The above summary of the present invention is not intended to describe each embodiment or every implementation of the present invention. Advantages and attainments, together with a more complete understanding of the invention, will become apparent and appreciated by referring to the following detailed description and claims taken in conjunction with the accompanying drawings.

BRIEF DESCRIPTION OF THE DRAWINGS

[0013] **FIGS. 1A and 1B** are flowcharts of methods involving the use of electrodes coupled to an external respiratory therapy device in accordance with embodiments of the invention;

[0014] **FIGS. 2A-2D** are block diagrams of external respiratory therapy devices having one or more electrodes mechanically coupled to the respiratory therapy mask assembly and used in connection with generating electrocardiogram (ECG) signals in accordance with embodiments of the invention;

[0015] **FIGS. 2E-2F** are block diagrams of external respiratory therapy devices having one or more electrodes communicatively coupled to the respiratory therapy device controller and used in connection with generating ECG signals in accordance with embodiments of the invention;

[0016] **FIGS. 2G-2J** are block diagrams of external respiratory therapy devices having one or more electrodes mechanically coupled to the respiratory therapy mask

assembly and used in connection with detecting cardiac events in accordance with embodiments of the invention;

[0017] FIGS. 2K-2L are block diagrams of external respiratory therapy devices having one or more electrodes communicatively coupled to the respiratory therapy device controller and used in connection with detection of cardiac events in accordance with embodiments of the invention;

[0018] FIGS. 2M-2N are block diagrams of an external respiratory therapy device having cardiac electrodes communicatively coupled to an implantable medical device in accordance with embodiments of the invention;

[0019] FIG. 3A is a block diagram of an external respiratory therapy device including one or more electrodes mechanically coupled to the respiratory therapy mask assembly and a respiratory therapy controller incorporating an ECG signal processor in accordance with embodiments of the invention;

[0020] FIG. 3B is a block diagram of an external respiratory therapy device including one or more electrodes mechanically coupled to the respiratory therapy mask assembly and a respiratory therapy controller incorporating cardiac event detector in accordance with embodiments of the invention; and

[0021] FIG. 4 is a process flow diagram illustrating various optional processes that may be implemented using one or more electrodes coupled to an external respiratory therapy device.

[0022] While the invention is amenable to various modifications and alternative forms, specifics thereof have been shown by way of example in the drawings and will be described in detail below. It is to be understood, however, that the intention is not to limit the invention to the particular embodiments described. On the contrary, the invention is intended to cover all modifications, equivalents, and alternatives falling within the scope of the invention as defined by the appended claims.

DETAILED DESCRIPTION OF VARIOUS EMBODIMENTS

[0023] In the following description of the illustrated embodiments, references are made to the accompanying drawings which form a part hereof, and in which are shown by way of illustration, various embodiments by which the invention may be practiced. It is to be understood that other embodiments may be utilized, and structural and functional changes may be made without departing from the scope of the present invention.

[0024] Treatment of respiratory disorders may involve the use of an external respiratory therapy device. Respiratory therapy devices may include a respiratory mask assembly that fits over the patient's nose and/or face and directs a flow of gas to the patient. The mask assembly is connected through a tube to a control unit that controls the flow of air or other gas to the patient. Sensors on the mask, in the control unit, or elsewhere may facilitate control of the respiratory therapy delivered to the patient.

[0025] External respiratory therapy devices are often used to treat breathing disorders, such as sleep disordered breathing. Sleep apnea is a common form of sleep disordered breathing and is characterized by periods of interrupted

breathing during sleep. Apnea and other types of disordered breathing may be caused blockage of the airway due to prolapse of soft tissue into the throat (obstructive apnea) and/or by derangement of the central nervous system signals controlling the breathing reflex. The cessation of breathing may occur repeatedly during sleep, sometimes hundreds of times a night and sometimes for a minute or longer. Respiratory therapy for sleep disordered breathing typically involves the use of an external respiratory device during the night. The external respiratory therapy device delivers positive airway pressure to the patient. The positive air pressure acts as a pneumatic splint, keeping the patient's airway open and reducing episodes of disordered breathing.

[0026] Patient's suffering from respiratory disorders may concurrently experience cardiac dysfunction. Sleep apnea and cardiac arrhythmia are common comorbidities. Further, Cheyne-Stokes respiration is frequently observed in patients with congestive heart failure. Cheyne-Stokes respiration in congestive heart failure patients is associated with poor prognosis and may be used to track the progression of the disease. Cardiac arrhythmias have been associated with the hypoxia or autonomic arousal from sleep disordered breathing.

[0027] Although cardiac conditions and respiratory disorders are commonly found in combination, monitoring and/or treatment of the disorders is generally accomplished using separate medical devices. Respiratory disorders such as disordered breathing have traditionally been treated using the above-described external respiratory therapy devices. Monitoring cardiac conditions such as cardiac arrhythmia may be accomplished using a patient worn or carried monitor, for example, a Holter monitor, having electrodes attached to the patient's chest for detecting cardiac electrical activity. Cardiac conditions such as arrhythmia and congestive heart failure may also be monitored and/or treated using an implantable cardiac rhythm management (CRM) system.

[0028] The nightly use of an external respiratory therapy device by the patient provides an opportunity to detect and/or diagnose cardiac disorders in addition to respiration disorders. Embodiments of the invention involve the use of cardiac sensors used in cooperation with a respiratory therapy device. The cardiac sensors sense cardiac electrical activity used to generate an electrocardiogram signal. Further embodiments of the invention involve detecting cardiac arrhythmia based on the sensed cardiac electrical activity.

[0029] FIGS. 1A and 1B are flowcharts illustrating methods of using a cardiac electrical activity sensor disposed on a respiratory therapy device in accordance with embodiments of the invention. One or more electrodes are disposed 110, 130 on a respiratory therapy device in locations that facilitate sensing cardiac electrical activity. The electrodes may be positioned on a respiratory mask, mask strap, or in other locations of the respiratory therapy device from which cardiac signals can be sensed. In one embodiment, the sensed cardiac electrical activity is used 120 to generate an electrocardiogram (ECG) signal. In another embodiment, the sensed cardiac electrical activity signal is used 140 to detect arrhythmia.

[0030] FIGS. 2A-2F illustrate various embodiments for sensing cardiac activity and generating ECG signals using electrodes coupled to an external respiratory therapy device. In some embodiments, cardiac electrodes disposed on the

mask of an external respiratory device sense cardiac signals. Circuitry coupled to the electrodes generates an ECG waveform. The ECG waveform generating circuitry coupled to the electrodes may be disposed on the mask, within the CPAP controller, or in another location.

[0031] In the illustrative examples presented herein, the external respiratory therapy device is configured as a continuous positive airway pressure (CPAP) device 220 including a controller 220, tubing 222, and respiratory mask apparatus 224. Any type of external respiratory therapy device other than CPAP can alternatively be used, such as bi-level positive airway pressure devices, auto titrating positive airway pressure devices, nebulizers, respirators, ventilators, and other external respiratory therapy devices. The CPAP controller 220 develops a positive air pressure that is delivered to the patient's airway through tubing 222 and mask assembly 224. The positive airway pressure provided by the respiratory therapy device 200 acts as a pneumatic splint keeping the patient's airway open and reducing the severity and/or number of occurrences of disordered breathing due to airway obstruction.

[0032] A typical CPAP device delivers air pressure through a nasal mask worn by the patient. The application of continuous positive airway pressure keeps the patient's throat open, reducing or eliminating the obstruction causing apnea.

[0033] Positive airway pressure devices may be used to provide a variety of respiration therapies, including, for example, continuous positive airway pressure (CPAP), bi-level positive airway pressure (bi-level PAP), proportional positive airway pressure (PPAP), auto-titrating positive airway pressure, ventilation, gas or oxygen therapies. Some positive airway pressure devices may also be configured to provide both positive and negative pressure, such that negative pressure is selectively used (and de-activated) when necessary, such as when treating Cheyne-Stokes breathing, for example. The term CPAP will be used herein as a generic term for any device using forms of positive airway pressure (and negative pressure when necessary), whether continuous or otherwise.

[0034] In some embodiments (FIGS. 2A-2D), the one or more cardiac electrodes 226 are mechanically coupled to the respiratory therapy device 200. The electrodes 226 may be positioned on the mask assembly 224 of the external respiratory device 200. For example, electrodes 226 may be positioned on the mask, mask strap, or other appropriate location on the mask assembly in a location that facilitates sensing cardiac electrical activity. The mask assembly 224 serves to hold the electrodes 226 in place while the external respiration therapy is delivered to the patient.

[0035] In some configurations, the electrodes 226 are coupled to an ECG processor 221 that uses the cardiac signals sensed by the electrodes 226 to generate an ECG waveform. The ECG processor 221 may be disposed, for example, within or on the CPAP controller unit. The electrodes 226 may be coupled to the ECG processor 221 through a wire lead 260.

[0036] In some implementations, the ECG processor 221 may be positioned proximate the electrodes 226, for example, on the respiratory mask assembly. This configuration facilitates generation of an ECG waveform that may

be transmitted via a wireless communications link 270 to the CPAP controller 220 or other medical devices 230.

[0037] The ECG waveform generated by the ECG processor 221 may be printed on a printing device, displayed on a display device 231, stored in memory, and/or analyzed by circuitry disposed within the CPAP controller 220 and/or the cooperating medical device 230.

[0038] If the patient uses the external respiratory therapy device regularly, for example each night, data acquisition via the electrodes 226 coupled to the external respiratory device 200 allows a significant amount of information about the patient's cardiac functioning to be collected during each sleep period. In some implementations, the cooperating medical device 230 may comprise a patient-worn or patient-carried device. In other implementations, the medical device 230 may comprise an implantable device, for example, an implantable monitor or implantable therapy device.

[0039] In some embodiments (FIGS. 2C and 2D), the ECG processor 221 may be disposed within the medical device 230. The medical device 230 may additionally include circuitry for storing and/or analyzing the ECG signals. Information about the ECG signals may be downloaded from the medical device 230 to an external device for display, analysis, or storage, for example.

[0040] In one configuration, the electrodes 226 may be communicatively coupled to the external device 230 through a wire lead 260. In another configuration, additional circuitry, e.g., amplifiers and/or transmitter circuitry, may be used to provide a wireless link 270 between the cardiac electrodes 226 and the device 230.

[0041] In some embodiments (FIGS. 2E and 2F), one or more cardiac electrodes 226 may be positioned on the patient's chest, or another location suitable for sensing cardiac electrical activity. The cardiac electrodes may be communicatively coupled to the external respiratory device 200. For example, the sensors may be communicatively coupled to the CPAP controller 220 through a wire lead 260 (FIG. 2E). Alternatively, additional circuitry may be situated proximate the electrodes to facilitate communication with the CPAP controller 220 through a wireless communications link 270 (FIG. 2F).

[0042] FIGS. 2G-2L illustrate embodiments of the invention involving cardiac event detection using one or more cardiac electrodes 226 coupled to an external respiratory therapy device 200. In some embodiments (FIGS. 2G-2J), the electrodes 226 are mechanically coupled to the respiratory mask apparatus 224.

[0043] The respiratory mask apparatus 224 serves as a support for the electrodes 226 positioning the electrodes against the patient's face to facilitate sensing cardiac electrical activity. The electrodes 226 are coupled to an external or implantable cardiac event detector 228 through wired 260 or wireless 270 connections. In some embodiments (FIGS. 2G and 2H), the cardiac event detector 228 is disposed within or on the CPAP controller 220 housing. In other embodiments (FIGS. 2I and 2J), cardiac event detector 228 circuitry is separate from the CPAP controller 220.

[0044] FIGS. 2K and 2L illustrate embodiments of the invention wherein one or more cardiac electrodes 226 are positioned on the patient's chest or other location suitable

for sensing cardiac electrical activity. The electrodes are coupled to a cardiac event detector **228** of an external respiratory therapy device **200**. The electrodes **226** may be coupled to the cardiac event detector **228** through a wire lead **260** or through a wireless connection **270**.

[0045] The CPAP device **220** may optionally include a respiratory event detector **229**. In accordance with one implementation, the respiratory event detector may be used to provide feedback for therapy control. For example, CPAP therapy may be initiated or adjusted based on the presence, absence, severity, frequency and/or duration of disordered breathing events detected by the respiratory event detector.

[0046] If a respiratory event detector is included, the respiratory event detector and the cardiac event detector may be coupled to an event processor **280**. The event processor **280** may be used to detect physiological events, including events affecting one or more of the cardiac and pulmonary systems based on inputs from the cardiac and respiratory event detectors. The cardiac event detector, respiratory event detector and/or event processor may be employed to detect various cardiac and/or respiratory dysfunctions, including, for example, bradycardia, tachycardia, including atrial tachyarrhythmia, ventricular tachyarrhythmia and ventricular fibrillation, myocardial ischemia, and/or myocardial infarction. The event processor may compare occurrences of respiratory and cardiac events including one or more of the timing, severity, type, and occurrence rate of the respiratory and cardiac events and detect the physiological events based on these and/or other factors.

[0047] The cardiac event detection circuitry illustrated, for example, in **FIGS. 2I and 2J** may be implemented in a patient carried or patient worn device, or in an implantable device such as a cardiac defibrillator or pacemaker.

[0048] **FIG. 2M** illustrates an embodiment of the invention wherein one or more cardiac electrodes **226**, and circuitry used to establish a wireless communications link **270**, are disposed on the CPAP mask assembly **224**. In **FIG. 2M**, signals sensed by the cardiac electrodes are transmitted to an implantable device **290**, bypassing the CPAP controller **220**.

[0049] The implantable device **290** may comprise, for example, an implantable therapy device, such as an implantable electrical stimulation device or implantable drug pump. The implantable device may comprise an implantable monitor. In one implementation, the implantable device **290** may comprise an implantable pacemaker, defibrillator, cardioverter, cardiac resynchronizer, or other cardiac therapy devices that receives the ECG signals. In another implementation, the implantable device **290** may comprise an implantable loop recorder, such as a subcutaneous ECG recorder. The implantable device may include a cardiac event detector that analyzes the ECG signals to detect cardiac events including cardiac arrhythmia, ischemia, and/or myocardial infarction.

[0050] **FIG. 2N** illustrates an embodiment wherein the cardiac electrodes **226** are coupled to the CPAP device **220** through a wire lead. Signals received by the CPAP device **220** may be wirelessly transmitted to the implantable device **290** for storage, analysis or for other purposes.

[0051] **FIGS. 3A and 3B** are block diagrams of a medical system including an external respiratory therapy device that

may be used in connection with sensing cardiac electrical activity. **FIG. 3A** illustrates an embodiment that directed to generating an electrocardiogram signal in accordance with embodiments of the invention. **FIG. 3B** illustrates an embodiment that uses the sensed electrical cardiac activity to detect arrhythmia.

[0052] **FIGS. 3A and 3B** depict block diagrams of a CPAP device **300** having cardiac sensing capabilities in accordance with the present invention. The CPAP device includes a CPAP controller **310**, tubing **315**, and mask assembly **320**. The CPAP controller unit may include a respiratory event detector **340** configured to detect disordered breathing episodes, such as sleep apnea and/or hypopnea. Detection of disordered breathing may be used to initiate or adjust respiratory therapy delivered to the patient.

[0053] The CPAP controller unit **310** includes flow generator **312** that pulls in air through a filter. The flow generator **312** is controlled by the pressure control circuitry **313** to deliver an appropriate air pressure to the patient. Air flows through tubing **315** coupled to the CPAP device **310** and is delivered to the patient's airway through the mask assembly **320**. The CPAP controller **310** may be coupled through communications circuitry **360** to other computing devices **350**, such as a programmer or patient management server to facilitate storage, evaluation and/or display of the cardiac information.

[0054] In embodiments of the present invention, the mask apparatus **320** may comprise a nasal mask covering only the patient's nose. In other configurations the mask covers the patient's nose and mouth. One or more cardiac electrodes may be coupled to the CPAP device **300**. For example, the one or more cardiac electrodes **322, 324** may be incorporated on the respiratory therapy mask **320**. However, the one or more cardiac electrodes **322, 324** can be positioned in another location of the respiratory therapy device that facilitates acquisition of a cardiac signal and. For example, electrodes **322** can be incorporated in a respiratory mask strap (not shown).

[0055] As illustrated in **FIG. 3A**, the cardiac electrodes **322, 324** are communicatively coupled to signal processing circuitry **330** within the CPAP controller **310**. The cardiac activity information is used to generate an electrocardiogram signal. The ECG signal can be used by the CPAP control unit **310** to control the external respiratory therapy delivered to the patient. Additionally or alternatively, the ECG signal can be stored in memory **335**, used to generate an ECG display or printout, and/or evaluated for diagnostic or therapeutic purposes.

[0056] **FIG. 3B** illustrates a block diagram of an embodiment of the invention that involves detection of cardiac arrhythmia. In this configuration, cardiac electrodes **322, 324** positioned on the respiratory mask **320**, sense cardiac electrical activity. The electrodes **322, 324** are coupled to an arrhythmia detector **360** disposed within a housing of the respiratory therapy control unit **310**. The cardiac event detector **360** uses the cardiac electrical activity sensed by the electrodes **322, 324** to detect cardiac events, such as bradycardia, ventricular tachyarrhythmia, ventricular fibrillation, and/or other arrhythmic events. In one implementation, the cardiac event detector **360** may evaluate the cardiac electrical activity to determine heart rate and detect arrhythmia based on heart rate. In another implementation, the arrhyth-

mia detector **360** may analyze the morphology of the cardiac electrical activity signal and detect arrhythmia based on the morphology of the cardiac electrical activity signal. Other methods of arrhythmia detection are possible.

[0057] FIG. 4 illustrates various optional processes that may be facilitated using cardiac electrodes coupled to a respiratory therapy device. Cardiac electrical activity is sensed using electrodes coupled to an external respiratory therapy device **410**. According to one aspect of the invention, the sensed cardiac activity may be used to detect arrhythmia **420**. If arrhythmia is detected, an alarm may be generated **422**, such as an audible or visual alarm. The alarm may include various tones or signals to indicate more than one type of arrhythmic condition, for example. In one implementation, the alarm may involve wireless communication with a remote device, such as a cell phone or pager, for example.

[0058] The sensed cardiac activity may be used to generate **430** an ECG signal. The ECG signal may be stored and/or transmitted **432** to a separate device. For example, the ECG signal may be transmitted to a patient management server for further analysis. The ECG waveform may be displayed **434** on a display device or printed. The ECG signal may be used to initiate cardiac therapy **424** to treat an arrhythmia.

[0059] Detected cardiac events and detected respiratory events may also be analyzed to determine relationships between cardiac and respiratory events. The results of this comparison may be displayed, stored, transmitted or used to modify cardiac or respiratory therapy.

[0060] Acquisition of ECG signals over a period of time may be used to trend cardiac conditions and/or diagnose **436** cardiac dysfunction, for example. Further, the ECG signals may be evaluated may be used to adjust **438** the patient's therapy, such as the external respiratory therapy delivered to the patient.

[0061] The ECG signal may be analyzed to detect morphological characteristics and/or cardiac timing measurements indicative of heart status including, for example, RR interval, PP interval, AV interval, PR interval, QT interval and/or ST elevation. The ECG signal may be used to determine statistics derived from heart rates, such as heart rate variability and various cardiac timing measurements, including RR timings and AV delay timing. Various cardiac events and/or other indications of heart status may be determined based on the ECG signal, including arrhythmia, myocardial ischemia, and/or other events. These analyses may be used to identify patient's cardiac condition and adjust therapy.

[0062] A number of the examples presented herein involve block diagrams illustrating functional blocks used for in accordance with embodiments of the present invention. It will be understood by those skilled in the art that there exist many possible configurations in which these functional blocks can be arranged and implemented. The examples depicted herein provide examples of possible functional arrangements used to implement the approaches of the invention. The components and functionality depicted as separate or discrete blocks/elements in the figures in general can be implemented in combination with other components and functionality. The depiction of such components and functionality in individual or integral form is for purposes of clarity of explanation, and not of limitation. It is also understood that the components and functionality depicted

in the Figures and described herein can be implemented in hardware, software, or a combination of hardware and software.

[0063] Methods, devices, and systems in accordance with the present invention may incorporate one or more of the features, structures, methods, or combinations thereof described herein below. For example, a medical system may be implemented to include one or more of the features and/or processes described below. It is intended that such a method, device, or system need not include all of the features and functions described herein, but may be implemented to include one or more selected features and functions that provide unique structures and/or functionality.

[0064] Various modifications and additions can be made to the preferred embodiments discussed hereinabove without departing from the scope of the present invention. Accordingly, the scope of the present invention should not be limited by the particular embodiments described above, but should be defined only by the claims set forth below and equivalents thereof.

What is claimed is:

1. A medical system, comprising:

one or more cardiac electrodes coupled to an external respiratory therapy device, the one or more cardiac electrodes configured to sense cardiac electrical activity; and

circuitry configured to generate an electrocardiogram (ECG) signal based on the sensed cardiac electrical activity.

2. The system of claim 1, wherein the external respiratory therapy device comprises a positive airway pressure device.

3. The system of claim 1, wherein the external respiratory therapy device comprises a respiratory therapy mask and the one or more cardiac electrodes are mechanically coupled to the respiratory therapy mask.

4. The system of claim 1, wherein the external respiratory therapy device comprises a strap for securing a respiratory mask to a patient and the one or more cardiac electrodes are mechanically coupled to the respiratory mask strap.

5. The system of claim 1, wherein:

the one or more cardiac electrodes are configured to be disposed on a thorax of a patient; and

the circuitry configured to generate the electrocardiogram (ECG) signal is configured as a component of the external respiratory therapy device and is disposed within an external respiratory therapy device housing.

6. The system of claim 1, further comprising a display device configured to display information associated with the ECG signal.

7. A medical system, comprising:

one or more sensors coupled to an external respiratory therapy device, the one or more sensors configured to sense electrical activity of a heart and to generate a cardiac electrical signal based on the sensed electrical activity; and

a cardiac event detector coupled to the one or more sensors and configured to detect one or more cardiac events based on the sensed electrical activity.

8. The medical system of claim 7, wherein the one or more sensors are mechanically coupled to an external respiratory therapy mask assembly.

9. The medical system of claim 7, wherein the cardiac event detector is disposed within a housing of the external respiratory therapy device.

10. The medical system of claim 7, wherein the one or more sensors are communicatively coupled to the cardiac event detector through a wireless communication link.

11. The medical system of claim 7, wherein the cardiac event detector is configured to detect myocardial ischemia.

12. The medical system of claim 7, wherein the cardiac event detector is configured to detect myocardial infarction.

13. The medical system of claim 7, wherein the cardiac event detector is configured to detect arrhythmia.

14. The medical system of claim 7, further comprising an alarm unit coupled to the cardiac event detector, the alarm unit configured to generate an alarm responsive to the detection of the one or more cardiac events.

15. The medical system of claim 7, further comprising a display unit coupled to the cardiac event detector and configured to display information about the cardiac events.

16. The medical system of claim 7, wherein the external respiratory therapy device further comprises a respiratory event detector configured to detect one or more respiratory events.

17. The medical system of claim 16, further comprising an event processor coupled to the cardiac event detector and the respiratory event detector, the event processor configured to detect relationships between the cardiac events and the respiratory events.

18. A method, comprising:

sensing cardiac electrical activity using one or more cardiac electrodes coupled to an external respiratory therapy device; and

generating an electrocardiogram (ECG) signal based on the sensed cardiac electrical activity.

19. The method of claim 18, wherein sensing the cardiac electrical activity comprises sensing the cardiac electrical activity using the one or more cardiac electrodes mechanically coupled to a respiratory mask assembly.

20. The method of claim 18, wherein sensing the cardiac electrical activity comprises sensing the cardiac electrical activity using the one or more cardiac electrodes disposed on a patient and communicatively coupled to the external respiratory therapy device control unit.

21. The method of claim 18, further comprising displaying the ECG signal.

22. A method, comprising:

sensing cardiac electrical activity using one or more cardiac electrodes coupled to an external respiratory therapy device; and

detecting cardiac events based on the sensed cardiac electrical activity.

23. The method of claim 22, wherein detecting the cardiac events based on the sensed cardiac electrical activity comprises detecting arrhythmia.

24. The method of claim 22, further comprising:

detecting respiratory events; and

controlling respiratory therapy delivered by the respiratory therapy device based on the detected respiratory events.

25. The method of claim 22, further comprising:

detecting respiratory events; and

determining relationships between the detected respiratory events and the detected cardiac events.

26. A system, comprising:

means for sensing cardiac electrical activity;

means for generating an electrocardiogram (ECG) signal based on the sensed cardiac electrical activity; and

means for delivering an external respiratory therapy to a patient, wherein the means for delivering the external respiratory therapy are coupled to the means for sensing the cardiac electrical activity.

27. The system of claim 26, further comprising means for displaying the ECG signal.

28. A system, comprising:

means for sensing cardiac electrical activity; and

means for detecting cardiac events based on the sensed cardiac electrical activity; and

means for delivering an external respiratory therapy to a patient, wherein the means for sensing the cardiac electrical activity is coupled to the means for detecting the cardiac events.

29. The system of claim 28, further comprising:

means for detecting respiratory events; and

means for using the detected respiratory events to control the means for delivering the external respiratory therapy.

30. The system of claim 28, further comprising:

means for detecting respiratory events; and

means for determining relationships between the detected respiratory events and the detected cardiac events.

* * * * *

专利名称(译)	使用外部呼吸治疗设备来检测心脏电活动		
公开(公告)号	US20050076905A1	公开(公告)日	2005-04-14
申请号	US10/922351	申请日	2004-08-19
[标]申请(专利权)人(译)	STAHMANN JEFFREYé 哈特利JESSE W LEE KENT 倪泉		
申请(专利权)人(译)	STAHMANN JEFFREY E. 哈特利JESSE W. LEE KENT NI QUAN		
当前申请(专利权)人(译)	STAHMANN JEFFREY E. 哈特利JESSE W. LEE KENT NI QUAN		
[标]发明人	STAHMANN JEFFREY E HARTLEY JESSE W LEE KENT NI QUAN		
发明人	STAHMANN, JEFFREY E. HARTLEY, JESSE W. LEE, KENT NI, QUAN		
IPC分类号	A61B5/00 A61B5/0205 A61B5/0215 A61B5/042 A61B5/0464 A61B5/0476 A61B5/0488 A61B5/0496 A61B5/053 A61B5/08 A61B5/083 A61B5/085 A61B5/087 A61B5/103 A61B5/113 A61M15/00 A61M16 /00 A61M16/10 A61N1/18 A61N1/20 A61N1/362 A61N1/365 A61N1/37		
CPC分类号	A61B5/0031 A61B5/6823 A61B5/0215 A61B5/02405 A61B5/0421 A61B5/0422 A61B5/0464 A61B5 /0476 A61B5/0488 A61B5/0496 A61B5/053 A61B5/0809 A61B5/0836 A61B5/087 A61B5/103 A61B5 /1116 A61B5/113 A61B5/4818 A61B2562/0219 A61M16/0051 A61M16/10 A61M2016/0021 A61M2016 /0039 A61M2016/0042 A61M2205/3561 A61M2205/3592 A61M2230/04 A61M2230/10 A61M2230/432 A61M2230/435 A61M2230/60 A61M2230/63 A61M2230/65 A61N1/362 A61N1/3627 A61N1/36514 A61N1/36592 A61N1/37 A61B5/686 A61B5/02055 A61B5/6803 A61M16/024		
优先权	60/504356 2003-09-18 US		
其他公开文献	US7364547		
外部链接	Espacenet USPTO		

摘要(译)

方法和系统提供呼吸和心脏监测，诊断和/或治疗的综合方法。医疗系统包括耦合到外部呼吸治疗设备的一个或多个心脏电极。心脏电极感测用于产生心电图 (ECG) 信号的心脏电活动。可以基于感测的心脏电活动检测心律失常，心肌梗塞和/或局部缺血等心脏事件。

