



(11) **EP 2 789 291 B1**

(12) **EUROPEAN PATENT SPECIFICATION**

(45) Date of publication and mention of the grant of the patent:
17.10.2018 Bulletin 2018/42

(51) Int Cl.:
A61B 1/313 ^(2006.01) **A61B 1/07** ^(2006.01)
A61B 1/018 ^(2006.01) **A61B 5/00** ^(2006.01)
G02B 21/00 ^(2006.01) **G02B 23/24** ^(2006.01)

(21) Application number: **14162978.2**

(22) Date of filing: **09.11.2001**

(54) **SPECTRALLY ENCODED MINIATURE ENDOSCOPIC IMAGING PROBE**
SPEKTRALKODIERTER MINIATURENDOSKOPISCHER BILDSENSOR
SONDE D'IMAGERIE ENDOSCOPIQUE MINIATURE CODÉE SPECTRALEMENT

(84) Designated Contracting States:
**AT BE CH CY DE DK ES FI FR GB GR IE IT LI LU
MC NL PT SE TR**

(30) Priority: **10.11.2000 US 709162**

(43) Date of publication of application:
15.10.2014 Bulletin 2014/42

(62) Document number(s) of the earlier application(s) in accordance with Art. 76 EPC:
01991471.2 / 1 343 411

(73) Proprietor: **The General Hospital Corporation
Boston, MA 02114 (US)**

(72) Inventors:
• **TEARNEY, Guillermo J.
Cambridge, MA 02139 (US)**

- **BOUMA, Brett Eugene
Quincy, MA 02171 (US)**
- **SHISKOV, Milen Stefanov
Boston, MA 02108 (US)**
- **ROSEN, Jonathan, Jay
Newton, MA 02458 (US)**

(74) Representative: **Barker Brettell LLP
100 Hagley Road
Edgbaston
Birmingham B16 8QQ (GB)**

(56) References cited:
**WO-A-99/44089 US-A- 4 585 349
US-A- 5 785 651**

EP 2 789 291 B1

Note: Within nine months of the publication of the mention of the grant of the European patent in the European Patent Bulletin, any person may give notice to the European Patent Office of opposition to that patent, in accordance with the Implementing Regulations. Notice of opposition shall not be deemed to have been filed until the opposition fee has been paid. (Art. 99(1) European Patent Convention).

Description**Field of the Invention**

5 [0001] The present invention relates to the field of endoscopy in general and to an endoscope having a combination of high number of resolvable points using spectral encoding and contained in a diameter/space small enough to perform desired procedures.

Background of the Invention

10 [0002] Clinical use of endoscopic devices and probes has permitted physicians to view and diagnose target bodies, such as tumors, deposits, tears, thrombi, and the like. Unfortunately, there are still a number of disadvantages and limitations of using conventionally available endoscopes. The diameter of currently available probes limits their use to certain procedures and locations that can accommodate the large diameter of the endoscope. Consequently, many
15 procedures currently done surgically could be done endoscopically, if a small enough probe was available with a sufficient number of resolvable points.

[0003] Current endoscopic procedures generally require administration of anesthesia and surgical training for insertion. Certain procedures cannot currently be done endoscopically because of the diameter of existing probes. Probe size is proportional to the likelihood of tissue damage occurring during the procedure. Another problem associated with current
20 probes is the occurrence of adverse reactions, such as in fetoscopy, where the risk to the fetus is high. Neural imaging carries with it the possibility of brain damage. Spinal canal and brain ventricular imaging have complications of spinal fluid leakage and headaches which are more frequent and severe with larger diameter probes. Catheterization of the pancreatic duct is also problematic due to the probe size and resultant complications which include acute pancreatitis. Also, the size of the incision necessary to insert current probes results in longer healing time and more prominent scarring.

25 [0004] Present day miniature endoscopes are composed of fiber-optic imaging bundles. Currently, the clinical use of small diameter endoscopes is limited by poor resolution. Available miniature endoscopes have diameters in the range of from about 0.35 mm to about 1.0 mm. Since optical fibers are of finite diameter, only a limited number of fibers can be incorporated into one imaging bundle, resulting in a limited number of resolvable elements. For example, for a 1 mm fiber optic imaging bundle with an individual fiber diameter of 10 μm , the total number of resolvable points is 9000 with
30 100 resolvable points across the field of view. In addition, the fill factor is about 85% resulting dead space from the cladding material and causing the image to have a pixelated or "honeycomb" appearance. These two technical problems have severely limited the clinical use of currently available sub-millimeter diameter imaging probes. In order to achieve a higher number of resolvable elements with such probes, larger diameters must be used, which obviate their use in smaller spaces and eliminate certain procedures from being done endoscopically. If one uses a currently available probe in the sub-millimeter diameter range, the number of resolvable points obtainable drops below clinically useful levels.
35 Present endoscopes have a light transmission efficiency of up to about 50%.

[0005] A further disadvantage of fiber bundles is that crosstalk occurs, reducing the signal to noise level. Moreover, as fiber length increases, light transmission efficiency decreases. Also with current fiber optic endoscopes, coupling illumination light into the fiber optic imaging bundle is difficult. As a result, miniature endoscopes need two separate fiber
40 bundles, one for illumination and one for detection of the image. The need for distinct illumination and detection bundles increases (at least doubles) the overall endoscope diameter. It would therefore be desirable to have a long length endoscope probe that retains sufficient light transmission efficiency to provide a clinically useful image and information.

[0006] Another disadvantage of optical fiber bundles is that individual fibers may be broken or have defects at their faces, resulting in "dead" pixels. The use of one fiber would greatly minimize the presence of dead pixels.

45 [0007] Thus, it would be desirable to have a probe that provided a satisfactory number of resolvable elements in a space/diameter below a certain size that would enable procedures to be done currently not achievable by currently available endoscopes. It would be desirable to have a probe in the sub-millimeter diameter range that had optics that would improve the number of resolvable points, reduce deadspace/fill factor, and minimize risk of adverse consequences to the patient. Such a novel probe would enable procedures to be performable that currently cannot be attempted
50 endoscopically, such as, but not limited to, otological, neural, pancreatic, and fetal surgical endoscopy. It would also be desirable to have a sub-millimeter endoscope that would allow for diagnosis as well as treatment in a single device.

[0008] Spectral encoding is a method that allows detection of a one-dimensional line of an image using a single optical fiber. Encoding the spatial information on the sample is accomplished by using a broad bandwidth source as the input to the endoscope. The source spectrum is dispersed by a grating and focused by a lens onto the sample. The spot for
55 each wavelength is then focused at a separate position, x , on the sample. The reflectance as a function of transverse location is determined by measuring the reflected spectrum. The other dimension of the image can be obtained by mechanical scanning at a slower rate. The advantage of this mode of imaging is that the fast scanning needed to produce an image at or near video frame rates is performed externally to the probe, making the construction of small diameter

probes feasible.

Summary of the Invention

5 [0009] The present invention discloses a miniature imaging probe or endoscope that is capable of obtaining real-time images with up to or higher than about 100 times the number of resolvable points than a fiber-optic imaging bundle of the same diameter. Another way of describing the present invention is for the same number of resolvable pixels as commercially available imaging bundles, the present invention could have a diameter that is 10 times smaller. In addition, this instrument produces images that do not contain cladding artifacts. Also, this invention allows acquisition of depth (three-dimensional, or 3D) information from the sample. Finally, by acquiring multiple images of the sample, spectroscopic information relating to the chemical composition of the object may be obtained. These properties make this device an enabling technology for performing endoscopic or catheter based imaging in previously inaccessible locations within the body. Important specific applications include fetoscopy, pediatric endoscopy, coronary angioscopy, mini-laparoscopy, mammary ductoscopy, lacrimal ductoscopy, small joint visualization, and other medical and non-medical applications.

10 [0010] Significant work related to this invention is described in copending application WO99/44089. This prior disclosure described the use of spectral encoding to perform endoscopic confocal microscopy. The present invention describes the use of spectral encoding to create small diameter endoscopes and obtain high-resolution macroscopic images. The present invention includes different embodiments and applications of spectral encoding for performing endoscopic imaging through small diameter probes.

15

20

Objects of the Invention

[0011] Accordingly, it is a principal object of the present invention to provide an endoscope having a combination of resolution above a certain level in a diameter or space below a certain size.

25 [0012] It is an object of the present invention to provide an endoscope having a combination of number of resolvable elements above about 10,000 in a space below about 1.0 mm².

[0013] It is another object of the present invention to provide an endoscope in the generally sub-millimeter diameter range that increases the number of resolvable elements.

[0014] It is also an object of the present invention to provide an endoscope that can be used in smaller spaces than currently available endoscopes.

30 [0015] It is another object of the present invention to provide an endoscope that can be used in conjunction with a small diameter needle so as to avoid anesthesia and where the endoscopic procedure can be done, where appropriate, on an outpatient basis.

[0016] It is another object of this invention to provide an endoscope which is simpler to manufacture and is less likely of having individual pixel defects than current fiber optic bundles.

35 [0017] It is a further object of the present invention to provide an endoscope using spectral encoding and using a single fiber.

[0018] It is yet another object of the present invention to provide an endoscope capable of obtaining spectroscopic information from the sample.

40 [0019] It is a further object of the present invention to provide a third dimension of information (depth), above the typical two dimensions of data obtainable from conventional endoscopes.

[0020] It is yet another object of the present invention to provide higher sensitivity and higher signal to noise ratio images for clearer visualization through turbid media.

[0021] It is still another object of the present invention to provide an endoscope that can reduce the likelihood of tissue damage and other adverse consequences.

45 [0022] It is another object of the present invention to provide an endoscope that allows for diagnosis and treatment in a single procedure.

[0023] It is yet a further object of the present invention to provide an endoscope having no fill factor problem.

[0024] It is yet another object of the present invention to provide an endoscope with no "dead" pixels.

50 [0025] Other objects, features and advantages of the present invention will become apparent upon reading the following detailed description of embodiments of the invention, when taken in conjunction with the appended claims.

Brief Description of the Drawings

55 [0026] The invention is illustrated in the drawings in which like reference characters designate the same or similar parts throughout the figures of which:

Fig. 1 is a schematic view of a spectrally encoded miniature camera according to a preferred embodiment of the

present invention.

Figs. 2A-F are schematic views of different possible configurations of the distal probe of the camera of Fig. 1.

5 Figs. 3A-C are schematic views of the image formation geometry for linear, sector and circular scans, respectively.

Fig. 4 is a schematic view of a preferred embodiment of the detection system of the camera of Fig. 1.

10 Fig. 5 is a schematic view of an alternative embodiment of the present invention showing a color spectrally encoded miniature camera.

Fig. 6 is a schematic view of an alternative embodiment of the present invention showing a multifiber array incorporating a plurality of grating lenses.

15 Fig. 7 is a schematic view of an alternative embodiment of the present invention showing an optical fiber having spaced lenses along its length.

Description of the Preferred Embodiments

20 **[0027]** The present invention provides in general an endoscopic probe having a small diameter and a high number of resolvable elements. For the purposes of the present disclosure, a probe diameter in the sub-millimeter range is most desirable; however, it is to be understood that diameters of or greater than 1 mm can be used with the present invention. The advantages of the resolution of the present invention certainly carry to probes with greater than 1 mm diameter. Thus, the present invention provides a combination of number of resolvable points above a certain level in a diameter or space below a certain level.

25 **[0028]** Fig. 1 shows an endoscope of a preferred embodiment consisting of main body 12 connected through a hybrid (optical and electrical) cable 14 to a probe 16. The cable 14 can instead be a discontinuity conducted across a gap (for example, optical, electrical or electromagnetic relay), discussed hereinbelow with respect to an alternative embodiment using a self-contained probe with a transmitter to a remote receiver/detector. The main body 12 incorporates a broadband source 18 that sends the illuminating light to the beam-redirecting element 20. In different designs this beam-redirecting element 20 can be a beam splitter (simple, inexpensive, but poor light efficiency), a polarizing splitter, an optical circulator or other device known to those skilled in the art. This beam-redirecting element 20 sends out the light from the source 18 to the probe 16 and redirects the returning light from the probe 16 to the detection and display system 22. The detection system is preferably associated with a computer with a microprocessor (not shown).

30 **[0029]** The probe 16 has three major components. The proximal end 24 generates the one-dimensional scanning. In a preferred embodiment the scanning is done mechanically. A flexible, semi-flexible or rigid tube 26 connects the proximal end 24 and the distal end 28 of the imaging probe 16. An optical fiber conveys the optical signals and a hollow flexible, semi-flexible, or rigid cable conveys one-dimensional scanning of the sample 30.

35 **[0030]** The cable 14 is preferably a single mode optical fiber. Another embodiment is a double-clad fiber where the illumination is through the central core and the detection is through the central core and outer cladding. Alternatively, the cable 14 can be a coaxial or side-by-side pair of fibers, with one fiber being for illumination by the source and the other fiber being for collection of light reflected from the sample 30. In a device where a multimode fiber system is used, there may be increased sensitivity and decreased speckling. Speckle artifacts may also be reduced by introducing mode or phase modulation of the fiber. Mode or phase modulation may be performed by rapidly moving the optical fiber, or insertion of an optical element in the fiber path capable of rapidly changing modes or phase of the probe light. This embodiment includes the detection mechanism within the probe and a RF transducer to relay image information remotely to a RF detector).

Sources

50 **[0031]** The light source 18 can be any broadband source capable of performing high-resolution imaging using the spectral encoding method. Examples of sources include, but are not limited to, light-emitting diodes, super-luminescent diodes, rare-earth doped fibers, solid-state mode-locked lasers, spectrally broadened laser sources, wavelength tunable light sources, monochromatic light, polychromatic light, and the like. The source 18 does not need to illuminate all wavelengths simultaneously. It can emit a monochromatic radiation whose wavelength is scanned with time. This allows fluorescence illumination to be done. It also does not require Fourier transform to be done. It is to be understood that other sources of energy can be used, including, but not limited to, infrared, ultraviolet, ultrasonic, low or high energy radiation (for example, x-ray, alpha, beta, gamma, and the like), other electromagnetic radiation, combinations of all of

the foregoing and the like. For higher energy radiation, certain of the components of the present invention may need to be adapted for greater shielding or other functional characteristics.

Distal Probe Design

[0032] The distal probe 16 design of the present invention will now be discussed. Fig. 2 shows several possible configurations of the imaging head 28. The optics of the head 28 is designed to produce linear, spectrally encoded illumination and to collect the reflected light and transmit it back to the detection system 22. The light from the source 18 is delivered by the fiber 14 to the head 16 and focused by an objective 32 onto the sample 30. In a preferred embodiment the objective 32 is a lens, for example, but not by way of limitation, a GRIN (gradient index) lens, as is known to those skilled in the art. Other possible lens elements include, but are not limited to aspherical lenses, planoconcave, biconcave, concaveconvex or multi-element lens assemblies.

[0033] Immediately after (or before) the objective 32, a grating 34 is used to disperse the source spectrum. In a preferred embodiment, shown in Fig. 2A, the grating 34 is a holographic grating. Alternatively, blazed or binary gratings or a grism (grating prism or carpenter's prism) can be used. Holographic gratings, however, are believed to be better and have higher efficiency than blazed gratings for the intended use. Fiber gratings may also be used. The spot for each wavelength is focused at a separate position on the sample. The reflectance as a function of transverse location is determined by measuring the reflected spectrum. The head 16 also provides one-dimensional mechanical scanning orthogonal (or other angle) to the spectrally encoded axis. Spectral dispersion in one dimension while scanning the other dimension provides two-dimensional illumination of the sample.

[0034] Figs 2B-F illustrate alternative embodiments of the probe 16 design of Fig. 2A. On the Figures the elements are: optical fiber 14; imaging head 16; objective 32; diffracting grating 34 (Fig. 2A and 2D show a transmission grating, Figs. 2B, C and E show a reflecting grating 36, and Fig. 2F shows a fiber 38); a beam stop 40; a spectrally encoded imaging line 42; a mirror 44; a beam splitter 46; a polarizer 48; a polarizing beam splitting cube 50; and a 1/4 wavelength plate.

[0035] Image formation will now be discussed. The use of the dispersing element 34 and the focusing of the spectrum on the sample 30 to be imaged produces a one-dimensional scan. In order to obtain a two-dimensional image, one must perform a transverse scan in the conjugate direction. This can be implemented in many different embodiments, but all include a means of moving the spectrally encoded scan line. In a preferred embodiment the movement is achieved mechanically. Several possible methods for one-dimensional mechanical scanning are shown in Figs. 3 A-D. It is possible to use a piezoelectric transducer or a torque-transducing device known to those skilled in the art to achieve movement. The probe body 12 is associated with a transparent cap 60. A flexible cable 62 carries the fiber 14. The optical head 28 and the spectrally encoded imaging line 64 are shown. The two-dimensional imaging region is shown at 66. Fig. 3A shows a linear scan; Fig. 3B shows a sector scan; Fig. 3C shows a circular scan; and, Fig. 3D shows a forward circular scan. This may be performed by use of a rotating or linearly translating cable where the motion is produced at the proximal end of the endoscope. One can either rotate the optical head or push it linearly forth and back, moving the imaging line on the sample and scanning the image. The fiber may also be moved as opposed to the distal optics to give the alternate scan.

[0036] The proximal probe end design and coupling mechanisms will now be discussed. Referring back to Fig. 3, the proximal end 24 of the probe 16 provides the mechanical scanning necessary for obtaining a two dimensional image. In addition, this end couples the light coming from the source 18 to the distal end 28 of the probe 12 and the optical signal coming back from the sample 30. Linear (axial or radial), sector, or circumferential scanning patterns are possible depending on the application. For example, in narrow vessel imaging, such as angioscopy, circumferential scanning is necessary to image the total surface of the vessel. In this case a special rotating junction must be incorporated into the proximal end 24 of the probe 16 to connect optically a stationary and a rotating fiber 14. For sector and linear scanning, the optical fiber 14 within the probe 16 may be directly fused to the beam-redirecting element 20. The preferred scanning embodiment is sector or circumferential scanning due to the availability of small diameter cables already constructed for this purpose.

Resolution

[0037] The number of wavelengths or points that may be resolved is determined by:

$$\frac{\lambda}{\partial \lambda} = mN, \quad (1)$$

where λ is the center wavelength, $\Delta\lambda$ is the bandwidth of the spectrum, N is the number of lines in the grating illuminated by the polychromatic input beam, and m is the diffraction order. If the total bandwidth of the source is $\Delta\lambda$, the number of resolvable points, n is defined by:

$$n = \frac{\Delta\lambda}{\lambda}. \quad (2)$$

[0038] For an input source with a center wavelength of 1000 nm, a bandwidth of 200 nm, an input spot diameter of 1 mm, a diffraction grating of 1200 lines/mm and a diffraction order of 1, $n = 240$ points may be resolved by the spectrally encoded system. Moreover, if the grating is at an angle (θ) with respect to the incoming light, the number of resolvable points scales with $1/\cos(\theta)$. In the above example, for an incident angle of 65° , the number of resolvable points would be approximately $n = 570$. If the perpendicular direction was also scanned to give 570 points of resolution, the total number of resolvable points would be approximately 320,000. This is compared to 10,000 resolvable points ($n =$ about 80) found in state of the art single mode fiber bundles with a diameter of 1 mm. Thus, the present invention can provide approximately 16 times better resolution than conventional fiber optic probes.

[0039] The parameters used in this example may be found in common, inexpensive optical components. The number of points may be increased by simply increasing the input angle or the bandwidth of the source 18. Increasing the spot diameter increases the resultant probe diameter. Increasing the bandwidth of the source 18 could be accomplished by using a broader bandwidth superluminescent diode, a broad bandwidth LED, a rare earth doped fiber superfluorescent source, a solid state modelocked laser, a continuum source or the like.

[0040] Practitioners in endoscopic procedures would generally agree that a minimum number of resolvable elements of about $256 \times 256 = 65,536$ is needed to do meaningful diagnostic procedures. This is based on the fact that this is approximately the current accepted standard used in laparoscopic procedures. Current high end endoscopes have an upper end of about 10,000 elements in about a 1 mm diameter probe. Currently also, there are several fiber bundles that have 30,000 elements in about a 1 mm probe, but they are not yet in clinical use due to technical limitations.

[0041] The device of the present invention provides, in a preferred embodiment, a probe having a diameter of about 1.0 mm with a number of resolvable points in the range, in its broadest aspect, of from about 10,000 to about 1,000,000 resolvable points, more preferably, of from about 300,000 to about 1,000,000 resolvable points, more preferably of from about 150,000 to about 300,000 resolvable points, and still more preferably of from about 100,000 to about 150,000 resolvable points. The number of resolvable points roughly scales with diameter. It is to be understood by those skilled in the art that other diameters can be used with correspondingly greater or lesser numbers of resolvable points.

[0042] Table 1 provides a comparison of the number of resolvable elements using a spectrally encoded endoscope ("SEE") of the present invention compared to that using conventional fiber optic bundles. For the SEE, $\Delta\lambda$ (bandwidth) 250 nm, A (grating density) 1200 lines per mm.

TABLE 1

Diameter (mm)	Number of resolvable elements	
	Fiber Bundle	Spectral Encoded Endoscope
1.0	10000	160000
0.7	5000	80000
0.5	2500	40000
0.25	625	10000

Energy budget

[0043] The intensity I of the returned light in a Michelson interferometer configuration of the camera is given by

$$I = \frac{1}{8} \frac{\gamma_1^2 \gamma_2^2 d^2 \rho \varphi}{b^2 N} I_0, \quad (3)$$

where I_0 is the source intensity, γ_1 and γ_2 are the diffracting efficiencies of the imaging and detecting grating, d is the beam diameter at the objective, ρ is the reflectivity of the surface to be imaged (spectral and location dependent), φ is

a detector filling factor, and N is the number of the points to be detected.

[0044] The attenuation of the signal in dB ε is then given by

$$\varepsilon = 10 \log \frac{I}{I_0} = 10 \log \left[\frac{1}{8} \frac{\gamma_1^2 \gamma_2 d^2 \rho \varphi}{b^2 N} \right] \quad (4)$$

[0045] In this formula different contributions can be considered as follows

$$\varepsilon = 10 \log \frac{1}{8} + 10 \log G + 10 \log \Gamma + 10 \log \rho + 10 \log D, \quad (5)$$

15 where $G = \gamma_1^2 \gamma_2$ is the diffracting efficiency factor, $\Gamma = \frac{d^2}{b^2}$ is the numerical aperture factor, assuming a Lambertian

reflector, and $D = \frac{\varphi}{N}$ is detection system related N factor. For typical values of standard grating efficiencies and numerical apertures used in this device, the total attenuation would be approximately 60 dB. This number can be significantly improved by using custom designed diffraction gratings.

[0046] Detection will now be discussed.

Direct Spectral Measurement

25 [0047] The reflectance from the sample as a function of transverse location is determined by measuring the reflected spectrum from the sample arm. A simple and efficient direct measurement system 70 is shown in Fig. 4, in which an enclosure 71 houses the system 70 components.

[0048] The light returning from the imaging position carried by the fiber 14 is collimated by the objective 72 and dispersed by the grating 34. The scanning mechanism 72 is synchronized with the probe scanning mechanism or (in a compact design) the same scanning mechanism can be used to scan the probe and the detection system. This allows direct imaging using a camera 74, such as, but not limited to, a standard, inexpensive CCD camera that attaches to the detection system housing. An intensified CCD camera (ICCD) can be used when/if the signal is too weak. Electronic scanning with computer aided imaging can be implemented if a linear array is used as a detector. In this case no moving parts are necessary in the detection system 70 and higher detector sensitivity can be achieved. The detection system 70 can be either a single detector 70, a one dimensional array of detectors 70, or a two dimensional array of detectors 70. Other camera types and other detectors known to those skilled in the art are contemplated as being within the scope of the present invention.

[0049] For low light applications, the spectrum may be measured more efficiently by incorporating the device in the sample arm of an interferometer and detecting the light transmitted through a high-resolution spectrometer at the output port of the interferometer. Higher sensitivity may be achieved through the use of heterodyne detection when the light in the reference arm is modulated. The signal detected at the interferometer output will also be modulated. High signal-to-noise ratios may be then achieved by lock-in detection on the reference arm modulation frequency.

Interference Spectroscopy

45 [0050] Another method for measuring the spectrum is interference spectroscopy or Fourier transform spectroscopy. The advantages to this type of spectroscopic detection include the ability to achieve higher spectral resolutions than direct detection methods, efficient use of the returned light, inherent modulation of the reference arm by the Doppler shift of the moving mirror, the possibility of obtaining three-dimensional information, and the capability to extract both reflectance and phase data from the sample. The ability to extract phase data from the sample may allow detection of refractive index as a function of transverse position, which could give insight into the molecular composition of the sample as well as provide an additional source of image contrast other than the reflectivity of the specimen. Also, interferometric detection has the potential to allow elimination of high order multiple scattering from the signal by coherence gating. Moreover, analysis of both the phase and amplitude of the interferometric signal allows detection of group delay and dispersion. In most cases, knowledge of the group delay gives information relating the distance of the probe to the object under inspection and dispersion provides information about the shape of the object under inspection. Finally, mechanical scanning may be eliminated if points on the object, perpendicular to the spectrally encoded axis, may be separated by coherence gating.

Color Embodiment

5 [0051] In an alternative embodiment of the present invention, shown in Fig. 5, a device 100 can be constructed that uses at least two and preferably three or more separate broadband source modules 110, for example, three sources centered at red (630nm) 102, green (540nm) 104, and blue (480nm) 106 to produce color images using this technique. It is to be understood that other colors, wavelengths and number of separate sources can be selected depending on various factors, including, but not limited to, the imaging environment, imaging target, measurements to be obtained, and the like. The three energy components can be separated after reflection from the sample 30 and recombined to form an image. Each of the source/detector modules 102, 104 and 106 for the three spectral bands transmits selected wavelength light to an optical mixer/separator 108, which selectively transmits the light toward the imaging head 109 and to the imaging optics 110 for the different colors. The light reflects off of the sample/imaging plane 112 back through the foregoing elements and is received by a color monitor 114.

10 [0052] One use of this embodiment is for illuminating a stained sample with one color light and detecting the reflected or retransmitted light which may be of a different wavelength or wavelengths with one or more fibers. For example, one can illuminate across the blue spectrum to detect fluorescence. This embodiment may be most practicable where the source is not broadband, but is a scanning wavelength source. In a variation of this embodiment, an imaging device has a plurality of probes, each probe comprising an energy source, optical fiber, lens, etc., as described in the preferred embodiment. Each fiber has a distal end that is polished at an angle different from each other such that an energy source transmitted through each fiber is focused onto a distinct target site.

Multispectral Embodiment

15 [0053] By acquiring multiple images at different locations with the spectrally encoded probe, spectroscopic information within the bandwidth of the illuminating source may be obtained. Since each point on the sample is encoded by a different wavelength, moving the probe while acquiring images allows multiple wavelengths to be obtained from a single point on the specimen. Accumulation of these wavelengths reflected from the sample allows construction of a hyperspectral data set for each point in the image.

Multifiber Array Embodiment

20 [0054] In yet a further alternative embodiment of the present invention, shown in Fig. 6, an imaging apparatus is provided comprising: an elongated hollow generally cylindrical body ; a plurality of optical fibers defining an array disposed at least partially within the body each fiber having a distal end ; a plurality of lenses, each lens associated with a distal end of each optical fiber as part of said array, such that each lens is capable of focusing energy transmitted from an energy source (not shown) through the array on a distinct position on a target sample. Each optical fiber in the array has a different length such that each distal end and associated lens 210 does not substantially overlap any other lens in said array. This embodiment also incorporates a means, such as, but not limited to, mechanical, piezoelectric transducer or the like, for rotating said array about an axis.

Method

25 [0055] The present disclosure also provides a method for imaging, comprising: providing an endoscopic probe as described hereinabove, introducing the probe into a patient; transmitting a source energy signal to the probe such that the energy signal is directed at a sample; receiving the reflected energy from the sample; and, detecting the reflected energy.

Kits

30 [0056] The present invention provides a kit for performing an endoscopic procedure, comprising a probe as described hereinabove, and at least one of the following: a disinfectant, an anesthetic, and a means for introducing the probe into a patient.

35 [0057] The present invention also provides a kit for performing a catheterization procedure, comprising a probe as described hereinabove, and at least one of the following: a guidewire, an introducer, a syringe, an expander, and an introducer catheter.

Applications

40 [0058] In one embodiment, the present invention may be deployed through a needle with a gauge threshold of 20 or

higher. This embodiment would allow minimally invasive access to most internal organs for the purpose of primary diagnosis, screening, or biopsy guidance. For example, areas of the spinal cord can be viewed with the present invention because the needle gauge threshold of 20 gauge or higher is met by using the endoscope of the present invention. Previously inaccessible organs such as the ovaries might be screened using the present invention deployed through a needle. Liver, pancreas, and brain biopsies could be converted to higher yield procedures by using the present invention through a needle to localize the biopsy probe to a region more likely to yield diagnostic tissue.

[0059] Certain ophthalmological surgical procedures can only be performed through small holes in the cornea or sclera, allowing access to the iris, vitreous, retina, and other internal anatomic structures within the eye. Fetal diagnosis and/or surgery may pose less of a risk to the fetus when done using the assistance of the small diameter probe of the present invention. With various embodiments of the present invention procedures such as mammary ductoscopy, lacrimal ductoscopy, endoscopic ENT, small joint visualization, and spinal visualization can be performed.

[0060] The present invention can be used as part of a novel catheter for use in catheter-based imaging procedures. The potentially high signal-to-noise ratio of the present invention may allow imaging of the arterial wall without proximal arterial occlusion and complete vessel purging. In such an embodiment the endoscopic probe of the present invention is incorporated in one catheter lumen to provide imaging of the blood vessel or other environment into which the catheter is inserted. A second lumen can deliver therapeutics, such as, but not limited to, thrombolytic agents, plaque removing agents, antiplatelet agents, anticoagulants, vasoactive agents, combinations thereof, and the like. Alternatively, the second lumen can admit a plaque or thrombus breaking or removal device, such as, but not limited to, an ultrasonic, laser or cauterizing probe; a set of retractable teeth forming a claw for grabbing an intravascularly located body; a flushing or suction device for removing or diluting blood or other fluid which might obstruct imaging; a means for grasping a sample of material; or a cauterizing tip or the like may be employed. Alternatively, other devices, such as but not limited to, artificial a.v. fistula, other vascular access devices, and the like may be used. A catheter according to the present invention becomes possible for intravascular use only because of the small lumen size needed for the imaging probe as discussed above. Prior imaging probes were either too large or, if sufficiently small, of inadequate resolution, to be useful in a single device. With such a device, procedures previously impossible to perform efficiently now become possible.

[0061] In an alternative embodiment of the embodiment just discussed, a catheter can be constructed using a single fiber (or multiple fibers) in one lumen, whereby the fiber can be used for photodynamic therapy; i.e., imaging as well as delivering light-based therapeutic energy during a single procedure. Such energy may be magnetic, laser, ultraviolet, infrared, fluorescent, colored or other light energy. In such a device the imaging signal can be continuous or pulsed, such as alternately with the therapeutic light energy. One skilled in the art can appreciate the different permutations of pulsing, alternating, or other sequencing of imaging and therapeutic signals. Such sequencing can be controlled externally by a microprocessor or microcomputer which can be preprogrammed or manually operated by the user.

[0062] In a further alternative embodiment of such a catheter is a multifiber catheter, where one fiber or fibers transmit imaging light signal and another fiber or fiber transmits therapeutic light energy. Such a multifiber catheter may be desirable to have the image be where there is little absorption across the light spectrum; in other words, it is preferable to treat where there is high absorption. As such, it may be desirable to image and treat at different light wavelengths. In such a catheter where two fibers are used, the fibers can be arranged to be coaxial or side-by-side. In such a catheter the point of view of the image may be at a different point than the point of focus of the treatment light beam. If the treatment and imaging wavelengths are different, the angle of the treatment beam incident on the grating will need to be different than the angle of the imaging beam. In this case, slight adjustment of the treatment wavelength could allow direction of the treatment beam on the sample. Another alternative would be to put a dichroic (wavelength selective) beamsplitter in the distal optics of the probe that would direct the treatment beam towards the sample, while allowing the imaging light to pass through unaltered. In order to bring the angle back to the same point of focus the angle of incidence of light on the grating can be brought back. This can be achieved by polishing the end of each fiber at a different angle so that they both aim at the same target site when passed through the diffraction grating. In a further alternative a grism can be used in the distal optics. A grism is a grating placed in direct contact with a prism. By controlling the angle and the refractive index of the prism, this optical element allows for directing light in an arbitrary direction and compensates for the angular deviation of the diffracted beam from the grating. This is a very important element of the distal probe since it allows one to be able to control where one is looking (e.g., straight ahead, side view).

[0063] It is to be understood that with these embodiments using light that other electromagnetic energy wavelengths can be used with the present invention. In certain circumstances even beta, gamma or other radiation can be used in a targeted manner for treatment of cancer or other conditions while using a probed as described hereinabove in the same catheter to image the target site. Thus, such a catheter as described may be able to reduce a costly, expertise intensive surgical procedure to an outpatient one requiring less cost and expertise.

[0064] In a broad aspect of these alternative embodiments, the present invention contemplates providing one lumen for imaging and a second lumen for biopsy or irrigation to all mini-endoscopy applications, not just the cardiovascular system (catheter). For instance, in mammary ductoscopy, it was found that the second lumen was necessary for irrigation, insufflation and simultaneous imaging and biopsy.

[0065] In a further alternative embodiment, imaging can be achieved through the end of the fiber or through the side of the fiber. This can be used for a dual-purpose endoscope for imaging and biopsy or treatment.

[0066] Another alternative embodiment is a combination of an imaging device as described in the preferred embodiment and a microsurgical device.

[0067] In another embodiment of the present invention the imaging probe can be used in situations where a guidewire is typically deployed. The outside of the bundle of the catheter is a wound guidewire where the total diameter is less than about 0.3 mm. Push-pull to create the images as you advance the guidewire. The probe is the tip of the guidewire to correctly position the catheter and then to advance another catheter over the guidewire.

[0068] In another embodiment of the present invention scanned wavelength can be used, possibly in the telecommunications band. Scanning the wavelength will allow scanning of the beam at the distal end at a rapid speed. This would allow simplification of the detection electronics, since only the intensity of the light will need to be detected by a single detector as opposed to measuring the spectrum of light when broad bandwidth light is used.

[0069] One can use the time dependent output of a single detector to detect light, rather than having to use interferometry or a linear array.

[0070] Conventional probes are too large to be used in pancreatic tumor visualization without causing pancreatitis. The small size of the probe of the present invention allows it to be used in pancreatic tumor visualization while minimizing the incidence of pancreatitis.

Industrial applications

[0071] The submillimeter size of the probe of the present invention also allows for new industrial applications. One application can be the textillary weaving of a submillimeter fiber into a fabric.

[0072] An alternative embodiment of the present invention provides a multiplexed array of a plurality of fibers each fiber having an associated distal optics. More area can be scanned and the number of resolvable elements increases with this embodiment. Or, a single fiber with multiple diffraction elements spaced along the length of the fiber, e.g., a fiber grating can be used at 1 cm, a second fiber grating can be used at 2 cm, etc.

[0073] Another application is probe used as an inspection system, which comprises a cylindrical or other shape (regular or irregular) body having at least one and preferably a plurality of imaging fibers extending axially outward from the body in a regular or irregular array or arrays. Alternatively, the fibers can be flush or minimally protruding from the body. At one end of the body is an opening through which either the fibers or fiber passes which is connected to the detection apparatus. This detector fiber array can be used in pipes, conduits, or other closed or open systems not previously accessible to image longitudinally, three-dimensionally, panoramically, stereoscopically, and the like, using the multiple fiber array to image multiple points. This would allow for much more surface area and volume to be imaged and analyzed in a single procedure than previously possible. An array of this type can analyze inner wall defects in conduits and the like.

[0074] In a variation on this embodiment, shown in Fig. 7, a probe has a single optical fiber 300 which has a plurality of grating lenses 302(or other lenses) spaced along the surface 304 of the fiber 300. Each lens 302a, b, c, d, n focuses energy onto a distinct target site 306a, b, c, d, n.

[0075] Fluid properties can be measured dynamically using the present invention. Such an application can have a multifiber array probe within a very small tube. A dye or other detectable substance can be passed through the tube and the probe illuminate the fluid and detectable substance to obtain fluid flow dynamics in a given environment, such as were a weakness in the wall or partial obstruction has occurred. The present invention can be adapted to provide a surface built into the probe which can reflect illuminated light which has passed through an aliquot of fluid, thus permitting absorption measurements to be taken. Turbidity, color change, and other conditions may be detected in situ in small vessels, for example, kidney and gall bladder conditions (e.g., stones), seminal fluid composition, and the like. Alternatively, a cell can be constructed which can continuously admit and pass a fixed volume of fluid, thus permitting accurate measurement to be made of the cell volume in situ without requiring surgery, disruption or occlusion of the vessel. Much more accurate diagnosis can be made with the present invention rather than external measurements as must currently be made. With the small size of the present invention, coupled with the high resolution attainable, spaces previously impractical to be imaged can now be visualized.

[0076] The present invention can be developed into a self-contained remote controlled imaging probe where image data is transmitted by radio frequency or other signal from within the tube or vessel to an external receiver.

[0077] The present invention can also be used in veterinary applications for performing endoscopic procedures on small animals, fish, birds, reptiles and the like.

Advantages

[0078] The present invention provides for an imaging device capable of imaging at video rates or higher with up to or exceeding about one hundred times the number of resolvable points of currently available fiber optic bundles. The probe

of the present invention is single mode fiber based and can be flexible or rigid, according to required working parameters. No fill factor problem is encountered because a single fiber is used. Dead pixels are eliminated in the present invention. Light transmission efficiency is maintained because there is no crosstalk compared to multiple fiber bundles. High efficiency imaging, allowing clear visualization through turbid fluid may be obtained through heterodyne detection. Analysis of the group delay and dispersion of the light returned from the sample allows the acquisition of three-dimensional information from the object. Hyperspectral data may be obtained from a series of offset images.

[0079] The present invention can be used to convert many current surgical procedures into outpatient based procedures. Biopsy guidance, cancer screening, e.g., abdominal cavity, intracranial, spinal cord, are possible. The present invention is able to reach into spaces too small for current endoscopes and maintain a useful resolution level of obtainable information.

[0080] The probe of the present invention can fit through a 20 or higher gauge needle. Due to the small size of the probe, it may also not require anesthesia. Physicians and other medical personnel may be able perform procedures not previously doable by endoscopy. Also, lesser trained personnel may now be able to perform procedures previously performable only by specially trained physicians and/or surgeons. With the present invention one can package an endoscope having superior resolution in a diameter smaller than 1 mm, yet reduce the number of physical components that make up the endoscope.

[0081] Although only a few exemplary embodiments of this invention have been described in detail above, those skilled in the art will readily appreciate that many modifications are possible in the exemplary embodiments without materially departing from the novel teachings and advantages of this invention. Accordingly, all such modifications are intended to be included within the scope of this invention as defined in the following claims.

Claims

1. An endoscopic probe (10) for spectrally encoding a sample, comprising:
 - a lens element (32) configured to provide there through electro-magnetic radiation;
 - a dispersive arrangement (34, 36, 38) configured to receive the electro-magnetic radiation and forward a dispersed radiation to a sample (30) from which information is being obtained; and
 - means for scanning an image formed by the lens element (32) of the at least one section of the sample (30) by performing a transverse scan in the conjugate direction and obtaining the information that is spectrally-encoded information regarding the sample (30),
 - wherein the electro-magnetic radiation is provided by a wavelength tunable light source emitting a monochromatic radiation whose wavelength is scanned with time.
2. The apparatus according to claim 1, wherein the dispersive arrangement contains a diffractive element.
3. The apparatus according to claim 2, wherein the dispersive element is at least one of a fiber grating, a blazed grating, a binary, prism or a holographic lens grating.
4. The apparatus according to claim 1, wherein the lens arrangement contains at least one of a gradient index lens, a reflective mirror lens grating combination or a diffractive lens.
5. The apparatus according to any preceding claim, further comprising a detection system (22) which is configured to obtain the information based on a radiation obtained from the structure, wherein the information is at least one of a two-dimensional image or a three dimensional image.
6. The apparatus according to claim 5, wherein the at least one of the two-dimensional image or the three-dimensional image contains from about 300,000 to 1,000,000 resolvable points.
7. The apparatus according to claim 5, wherein the at least one of the two-dimensional image or the three-dimensional image contains from about 150,000 to 300,000 resolvable points.
8. The apparatus according to claim 5, wherein the at least one of the two-dimensional image or the three-dimensional image contains from about 100,000 to 150,000 resolvable points.
9. The apparatus according to claim 1, wherein the apparatus is a probe (16) having a diameter of in a sub-millimeter range.

10. The apparatus according to claim 1, wherein the apparatus is a probe (16) having a diameter of less than about 1.0 mm.

5 **Patentansprüche**

1. Endoskopische Sonde (10) zur spektralen Kodierung einer Probe, umfassend:

10 ein Linsenelement (32), das konfiguriert ist, um dadurch elektromagnetische Strahlung bereitzustellen;
eine dispersive Anordnung (34, 36, 38), die konfiguriert ist, um die elektromagnetische Strahlung zu empfangen
und eine dispergierte Strahlung an eine Probe (30) weiterzuleiten, von der Information erhalten wird; und
Mittel zum Abtasten eines durch das Linsenelement (32) gebildeten Bildes des zumindest einen Abschnitts der
Probe (30) durch Durchführen einer Querabtastung in der konjugierten Richtung und Erhalten der Information,
welche spektral kodierte Information über die Probe (30) ist,

15 wobei die elektromagnetische Strahlung durch eine wellenlängenabstimmbare Lichtquelle bereitgestellt wird,
die eine monochromatische Strahlung emittiert, deren Wellenlänge mit der Zeit abgetastet wird.

2. Vorrichtung nach Anspruch 1, wobei die dispersive Anordnung ein beugendes Element aufweist.

- 20 3. Vorrichtung nach Anspruch 2, wobei das dispersive Element zumindest eines von einem Fasergitter, einem Blazegitter, einem Binär-, Prismen- oder einem holographischen Linsengitter ist.

4. Vorrichtung nach Anspruch 1, wobei die Linsenanordnung zumindest eines von einer Gradientenindexlinse, einer
25 Kombination aus reflektierenden Spiegellinsengittern oder einer Beugungslinse aufweist.

5. Vorrichtung nach einem vorstehenden Anspruch, weiter umfassend ein Detektionssystem (22), das konfiguriert ist,
um die Information basierend auf einer von der Struktur erhaltenen Strahlung zu erhalten, wobei die Information
zumindest eines von einem zweidimensionalen Bild oder einem dreidimensionalen Bild ist.

- 30 6. Vorrichtung nach Anspruch 5, wobei das zumindest eine von dem zweidimensionalen Bild oder dem dreidimensionalen Bild von etwa 300.000 bis 1.000.000 auflösbare Punkte aufweist.

7. Vorrichtung nach Anspruch 5, wobei das zumindest eine von dem zweidimensionalen Bild oder dem dreidimensionalen Bild von etwa 150.000 bis 300.000 auflösbare Punkte aufweist.

- 35 8. Vorrichtung nach Anspruch 5, wobei das zumindest eine von dem zweidimensionalen Bild oder dem dreidimensionalen Bild von etwa 100.000 bis 150.000 auflösbare Punkte aufweist.

- 40 9. Vorrichtung nach Anspruch 1, wobei die Vorrichtung eine Sonde (16) mit einem Durchmesser im Sub-Millimeterbereich ist.

10. Vorrichtung nach Anspruch 1, wobei die Vorrichtung eine Sonde (16) mit einem Durchmesser von weniger als etwa
45 1,0 mm ist.

Revendications

1. Sonde endoscopique (10) pour coder spectralement un échantillon, comprenant :

50 un élément de lentille (32) configuré pour fournir à travers celui-ci un rayonnement électromagnétique ;
un agencement dispersif (34, 36, 38) configuré pour recevoir le rayonnement électromagnétique et transmettre
un rayonnement dispersé à un échantillon (30) duquel des informations sont obtenues ; et
un moyen de balayage d'une image formée par l'élément de lentille (32) de l'au moins une section de l'échantillon
(30) par réalisation d'un balayage transversal dans la direction conjuguée et obtention des informations qui
55 sont des informations codées spectralement concernant l'échantillon (30),
dans lequel le rayonnement électromagnétique est fourni par une source de lumière à longueur d'onde accordable émettant un rayonnement monochromatique dont la longueur d'onde est balayée avec le temps.

EP 2 789 291 B1

2. Appareil selon la revendication 1, dans lequel l'agencement dispersif contient un élément diffractif.
3. Appareil selon la revendication 2, dans lequel l'élément dispersif est au moins un parmi un réseau de fibre, un réseau blazé, un réseau binaire, prisme ou un réseau de lentille holographique.
- 5 4. Appareil selon la revendication 1, dans lequel l'agencement de lentille contient au moins une parmi une lentille à gradient d'indice, une combinaison de réseau de lentille miroir réfléchissant ou une lentille diffractive.
- 10 5. Appareil selon l'une quelconque des revendications précédentes, comprenant en outre un système de détection (22) qui est configuré pour obtenir les informations sur la base d'un rayonnement obtenu de la structure, dans lequel les informations sont au moins une parmi une image bidimensionnelle ou une image tridimensionnelle.
- 15 6. Appareil selon la revendication 5, dans lequel l'au moins une parmi l'image bidimensionnelle ou l'image tridimensionnelle contient d'environ 300 000 à 1 000 000 points résolubles.
- 20 7. Appareil selon la revendication 5, dans lequel l'au moins une parmi l'image bidimensionnelle ou l'image tridimensionnelle contient d'environ 150 000 à 300 000 points résolubles.
8. Appareil selon la revendication 5, dans lequel l'au moins une parmi l'image bidimensionnelle ou l'image tridimensionnelle contient d'environ 100 000 à 150 000 points résolubles.
- 25 9. Appareil selon la revendication 1, dans lequel l'appareil est une sonde (16) ayant un diamètre dans une plage de sous-millimètre.
- 30 10. Appareil selon la revendication 1, dans lequel l'appareil est une sonde (16) ayant un diamètre inférieur à environ 1,0 mm.

30

35

40

45

50

55

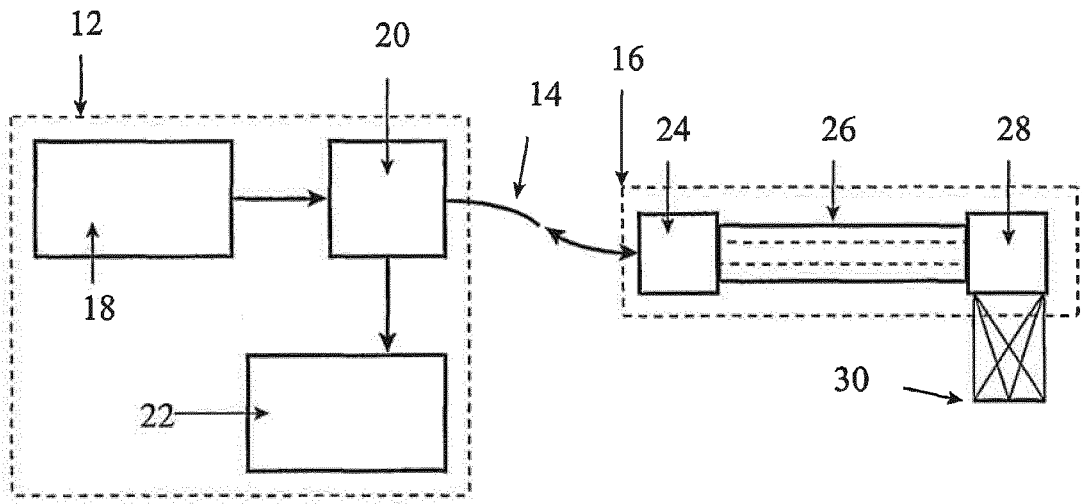

FIG. 1

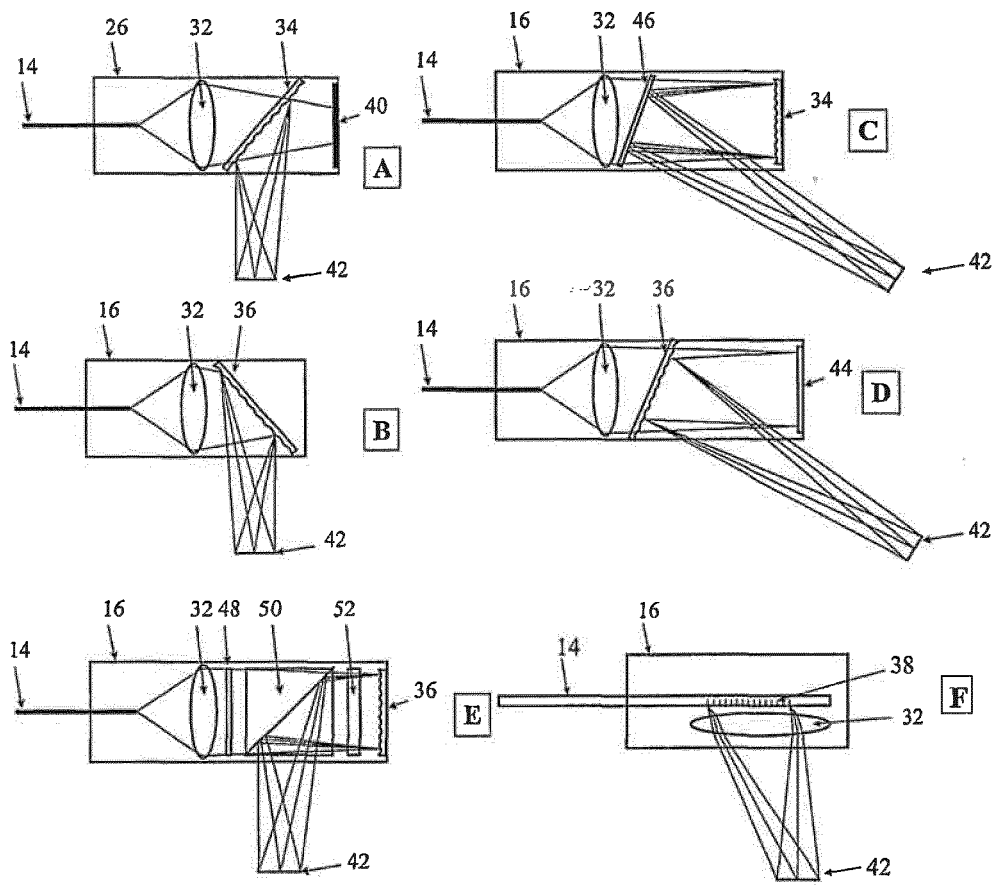

FIG. 2

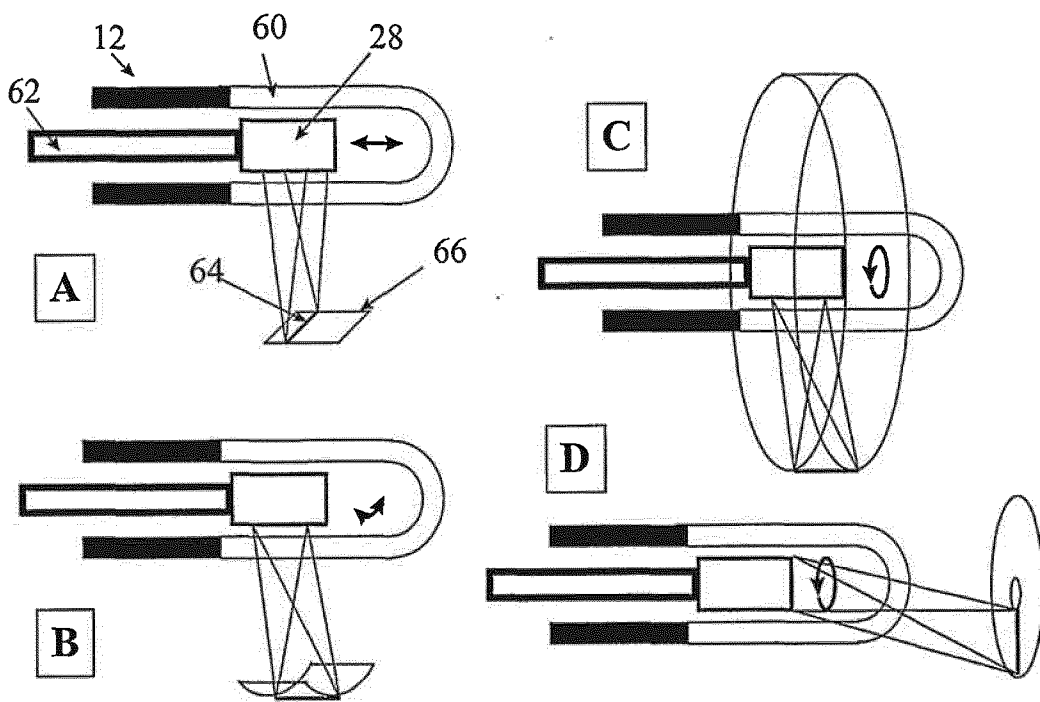

FIG. 3

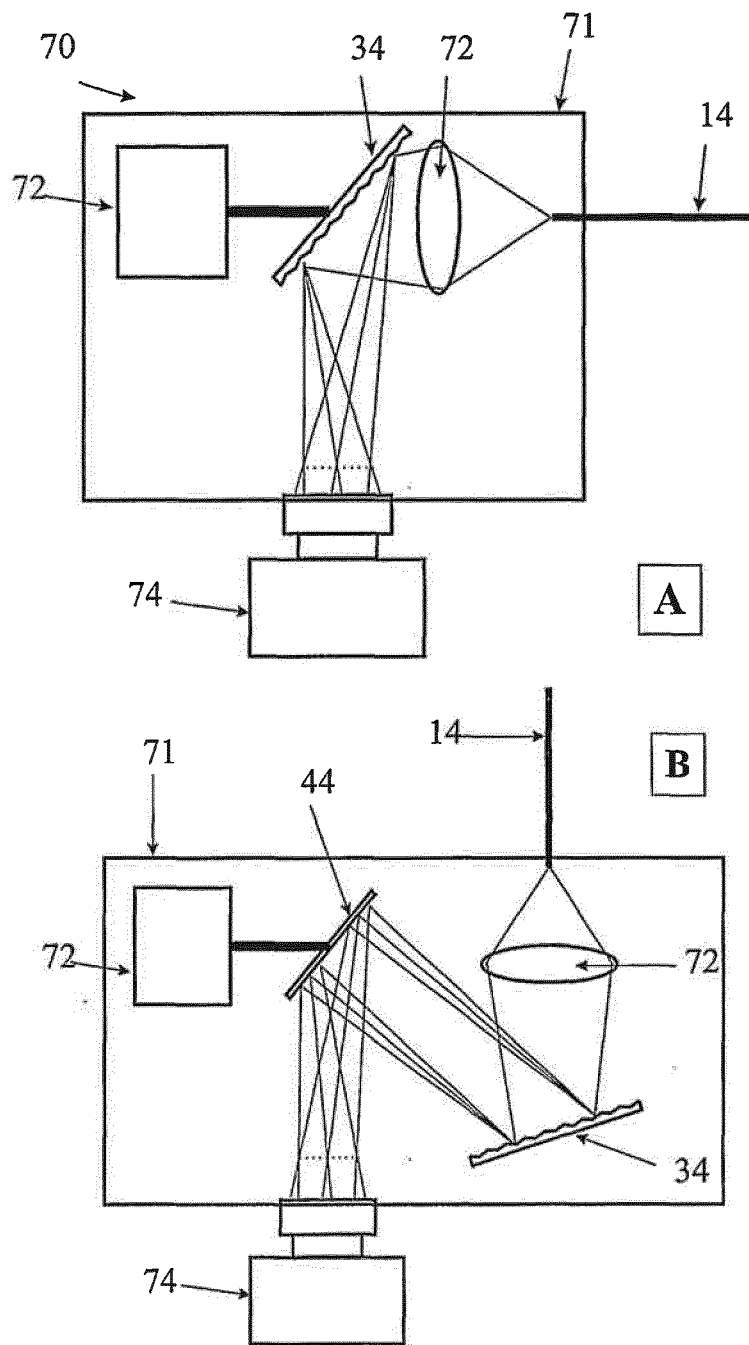

FIG. 4

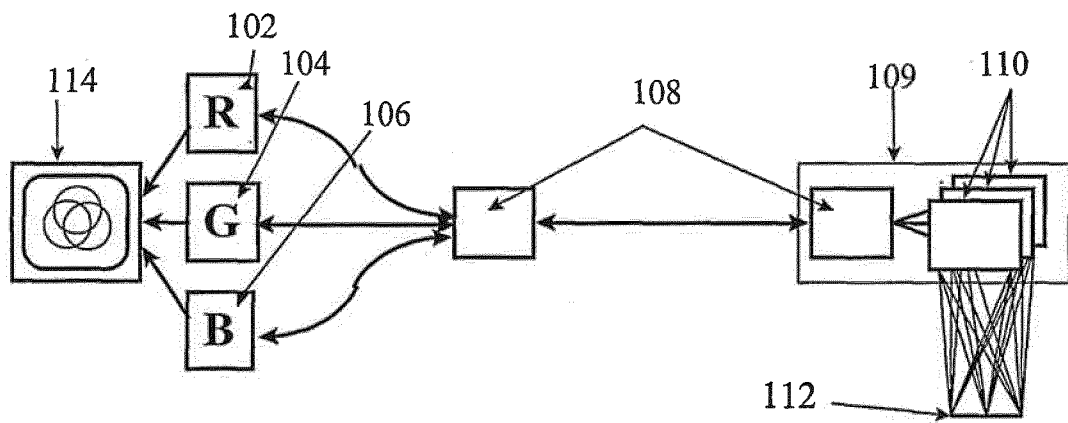

FIG. 5

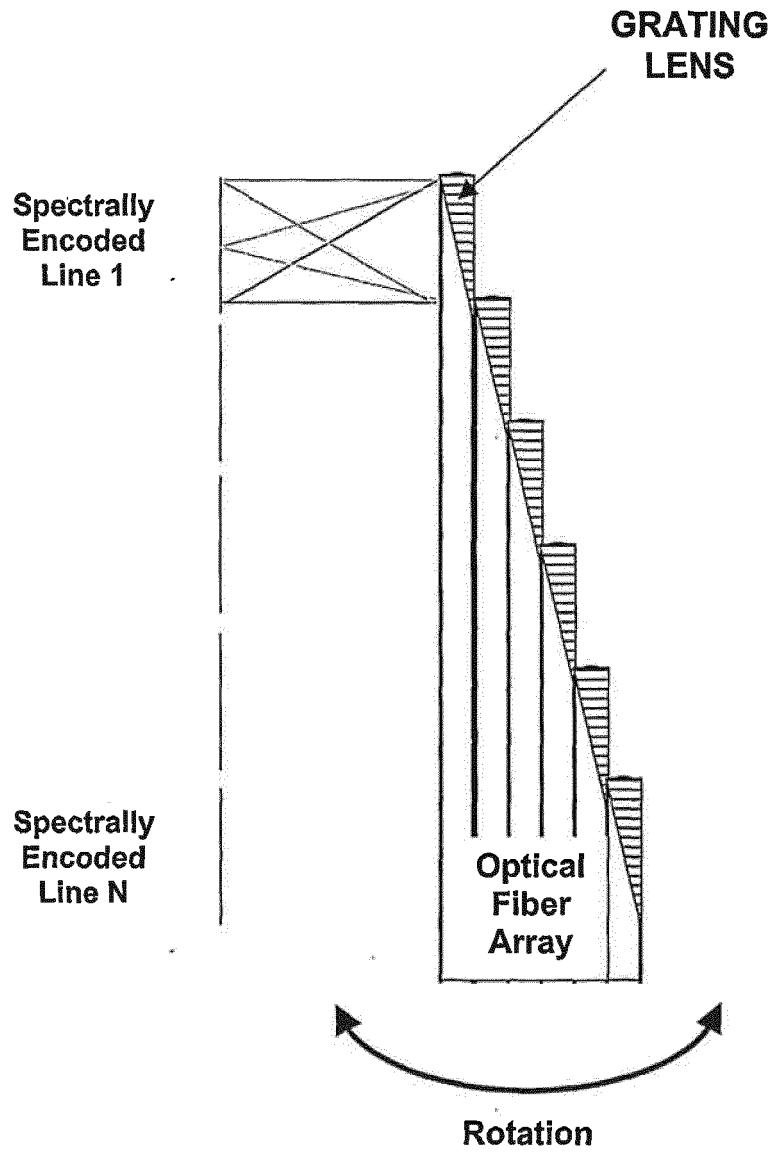

FIG. 6

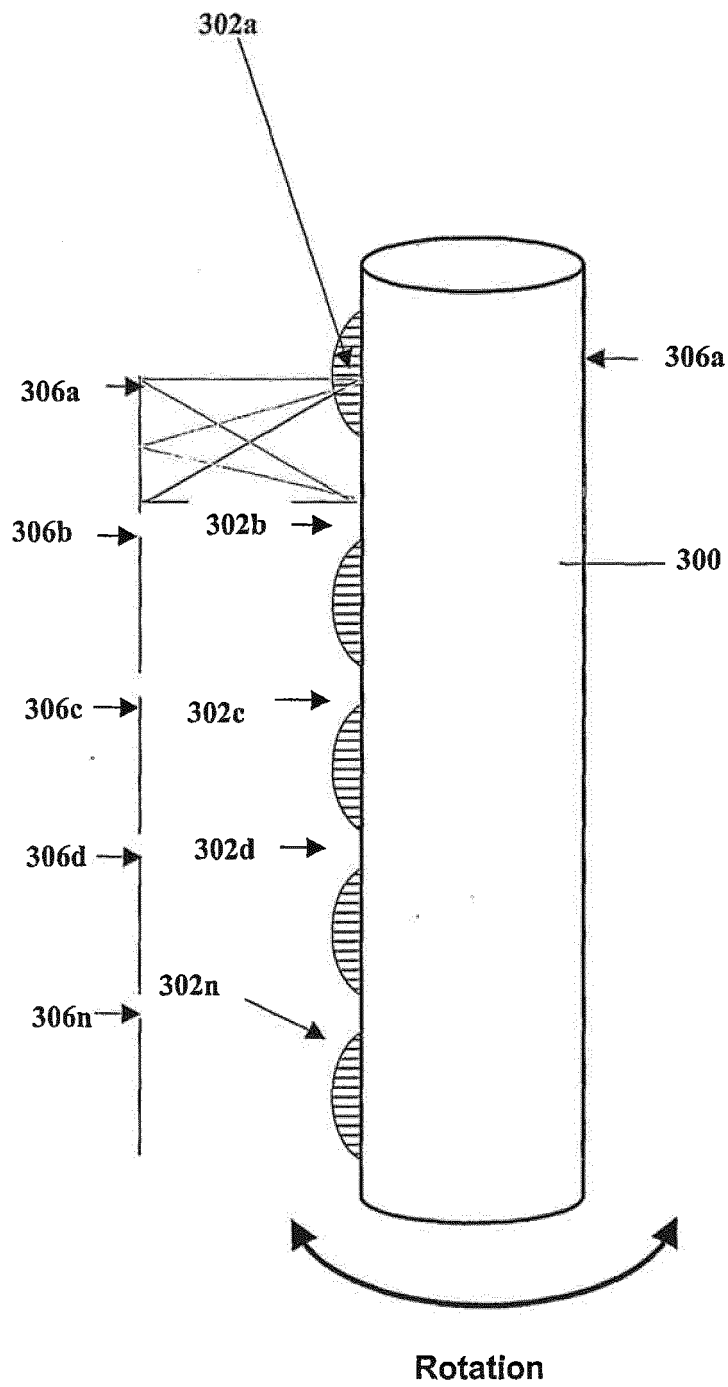

FIG. 7

REFERENCES CITED IN THE DESCRIPTION

This list of references cited by the applicant is for the reader's convenience only. It does not form part of the European patent document. Even though great care has been taken in compiling the references, errors or omissions cannot be excluded and the EPO disclaims all liability in this regard.

Patent documents cited in the description

- WO 9944089 A [0010]

专利名称(译)	光谱编码的微型内窥镜成像探头		
公开(公告)号	EP2789291B1	公开(公告)日	2018-10-17
申请号	EP2014162978	申请日	2001-11-09
[标]申请(专利权)人(译)	通用医疗公司		
申请(专利权)人(译)	总医院CORPORATION		
当前申请(专利权)人(译)	总医院CORPORATION		
[标]发明人	TEARNEY GUILLERMO J BOUMA BRETT EUGENE SHISKOV MILEN STEFANOV ROSEN JONATHAN JAY		
发明人	TEARNEY, GUILLERMO J. BOUMA, BRETT EUGENE SHISKOV, MILEN STEFANOV ROSEN, JONATHAN, JAY		
IPC分类号	A61B1/313 A61B1/07 A61B1/018 A61B5/00 G02B21/00 G02B23/24		
CPC分类号	A61B1/00096 A61B1/0017 A61B1/043 A61B1/07 A61B5/0062 A61B5/0071 A61B5/0084 G02B21/0036 G02B21/0048 G02B21/0064 A61B5/0059		
代理机构(译)	BARKER BRETTELL LLP		
优先权	09/709162 2000-11-10 US PCT/US2001/049704 2001-11-09 WO		
其他公开文献	EP2789291A1		
外部链接	Espacenet		

摘要(译)

可以提供内窥镜探针用于对样本进行光谱编码。示例性探针可以包括：透镜元件 (32)，被配置为通过电磁辐射提供；以及色散布置 (34,36,38)，被配置为接收电磁辐射的至少一部分并且向前传播分散的辐射。至少从样本 (30) 的一部分获得信息。探针还可以包括用于扫描由样品 (30) 的至少一部分的透镜元件 (32) 形成的图像的装置。电磁辐射可以由发射单色辐射的波长可调光源提供，该单色辐射的波长随时间扫描。

