

(19)



(11)

**EP 3 241 534 B1**

(12)

**EUROPEAN PATENT SPECIFICATION**

(45) Date of publication and mention of the grant of the patent:  
**13.02.2019 Bulletin 2019/07**

(51) Int Cl.:  
**A61F 13/42** <sup>(2006.01)</sup>      **A61B 5/00** <sup>(2006.01)</sup>  
**G08B 21/20** <sup>(2006.01)</sup>      **A61F 13/505** <sup>(2006.01)</sup>  
**A61F 13/84** <sup>(2006.01)</sup>

(21) Application number: **16206763.1**

(22) Date of filing: **23.12.2016**

**(54) MAGNETICALLY HELD DIAPER MONITOR**

MAGNETISCH GEHALTENER WINDELMONITOR

MONITEUR DE COUCHE-CULOTTE MAINTENU PAR AIMANT

(84) Designated Contracting States:  
**AL AT BE BG CH CY CZ DE DK EE ES FI FR GB GR HR HU IE IS IT LI LT LU LV MC MK MT NL NO PL PT RO RS SE SI SK SM TR**

- **Teng, Yudong**  
**Shenzhen, Guangdong 518108 (CN)**
- **Teng, Da**  
**Shenzhen, Guangdong 518108 (CN)**

(30) Priority: **06.05.2016 CN 201610296882**

(74) Representative: **Hellmich, Wolfgang**  
**European Patent and Trademark Attorney**  
**Lortzingstrasse 9 / 2. Stock**  
**81241 München (DE)**

(43) Date of publication of application:  
**08.11.2017 Bulletin 2017/45**

(73) Proprietor: **Shenzhen Hyan Microelectronics Co., Ltd.**  
**Shenzhen Guangdong 518108 (CN)**

(56) References cited:  
**CN-U- 204 814 433 CN-U- 204 833 626**  
**US-B1- 7 808 392**

(72) Inventors:  
• **Teng, Yujie**  
**Shenzhen, Guangdong 518108 (CN)**

**EP 3 241 534 B1**

Note: Within nine months of the publication of the mention of the grant of the European patent in the European Patent Bulletin, any person may give notice to the European Patent Office of opposition to that patent, in accordance with the Implementing Regulations. Notice of opposition shall not be deemed to have been filed until the opposition fee has been paid. (Art. 99(1) European Patent Convention).

## Description

### FIELD OF THE INVENTION

[0001] The present invention relates to an intelligent diaper, in particular to a magnetically held diaper monitor for an intelligent diaper.

### BACKGROUND OF THE INVENTION

[0002] The paper diapers and panty-shape diapers (hereinafter referred to as diapers) are used as daily necessities frequently used by infants and the aged. However, it is unavailable for a traditional diaper to judge whether or not a wearer has urinated or defecated from the appearance, a caregiver needs to observe the diaper frequently, and therefore, the wearer will often feel uncomfortable because the diaper is not changed timely.

[0003] Because some diapers are provided with sensors and alarm circuits, the caregiver may be reminded by an alarm signal sent after the wearer urinates or defecates, to clear and replace the diaper in time. But the alarm circuit part has higher cost and is combined with the diaper as disposable goods, and accordingly, the use cost is very high; cleaning and sterilization will be involved in the event that the alarm circuit part is repeatedly used, thereby being very inconvenient. To solve said problem, an improvement scheme in which a diaper sensor and a circuit part are designed separately, the sensor and the diaper are combined as a disposable part, and the sensor and the alarm circuit part are connected in a traditional pluggable connection manner is performed, such that the circuit part having higher cost can be used repeatedly. But, because the diaper sensor generally adopts a cloth substrate or a paper substrate, and is strip-shaped integrally, has a thickness less than 1 mm and is likely to bend, the defects of difficulty and unreliability in connection are caused due to the adoption of the traditional pluggable connection manner. Meanwhile, the diaper sensor is connected with the alarm circuit part in a pluggable connection manner, and then the alarm circuit part is directly provided with a button battery, thereby bringing difficulty to a waterproof design of an alarm product.

### SUMMARY OF THE INVENTION

[0004] To solve said defects existing in connection of a split diaper sensor and alarm product in the prior art, the present invention provides a magnetically held diaper monitor in which a split structure design is adopted to a control part, a power supply part and a sensor capable of being adhered to a diaper. The diaper sensor is clamped between the power supply part and the control part which are combined into a whole by attraction by means of a magnetic force, and reliable connection and power supply can be realized.

[0005] According to the diaper monitor of the present invention, a split design scheme is adopted to the control

part, the power supply part and the diaper sensor capable of being adhered to or built in the diaper. The power supply part and the control part between which the diaper sensor is tightly clamped are combined into a whole by attraction by means of the magnetic force via symmetrically configured magnetic electrodes and magnetic terminals. Conductive connecting parts of the diaper sensor are tightly crimped by the symmetrically configured magnetic electrodes to realize reliable connection with a circuit of the control part. The control part obtains a direct-current power supply from the power supply part through direct contact among the symmetrically configured magnetic terminals. Here, the magnetic electrodes refer to magnetic conductors, and meanwhile may be used as connecting electrodes and magnets. The magnetic terminals (or magnetic power supply terminals) refer to magnetic conductors, and meanwhile may be used as power supply terminals and magnets. The definitions of the magnetic electrodes and the magnetic terminals are applicable to the full text of the present invention.

[0006] The magnetically held diaper monitor of the present invention comprises a control part and a power supply part;

the power supply part comprises a lower shell having two positioning blind holes, a button battery and a power circuit board, wherein the button battery and the power circuit board are embedded in the lower shell through an insert injection molding process; a plurality of lower magnetic electrodes and two lower magnetic terminals are arranged at one end of the power circuit board, and the lower magnetic terminals and the lower magnetic electrodes penetrate out of a surface, where the positioning blind holes are located, of the lower shell;

the control part comprises an upper shell having two positioning pins and a control circuit board embedded in the shell through an insert injection molding process; upper magnetic electrodes which are in one-to-one correspondence to the lower magnetic electrodes and two upper magnetic terminals which correspond to the two lower magnetic terminals are arranged at one end of the control circuit board, and the upper magnetic terminals and the upper magnetic electrodes penetrate out of a surface, where the positioning pins are located, of the upper shell; the diaper sensor is clamped between the power supply part and the control part which are combined with into a whole by attraction via the lower magnetic electrodes, the lower magnetic terminals and the corresponding upper magnetic electrodes and upper magnetic terminals; and, conductive connecting parts of the diaper sensor can be tightly crimped by the lower magnetic electrodes and the upper magnetic electrodes to realize reliable connection with the control circuit board; the lower magnetic terminals directly contact the upper magnetic terminals, such that the control circuit board obtains a direct-current power supply from the power supply part.

[0007] In a preferred embodiment, three lower magnetic electrodes are arranged on the power circuit board; three upper magnetic electrodes are arranged on the

control circuit board; correspondingly, the diaper sensor also has three conductive connecting parts and positioning holes.

**[0008]** The power supply part, the diaper sensor and the control part are at a combined state, and the two positioning pins penetrating through the positioning holes in the diaper sensor are inserted into two positioning blind holes in the lower shell respectively to realize accurate positioning of the power supply part, the diaper sensor and the control part.

**[0009]** In the monitor, the lower magnetic electrodes, the lower magnetic terminals, the upper magnetic electrodes and the upper magnetic terminals are made from a magnetizable conducting material, for example, Nd-FeB, etc.

**[0010]** During implementation, the lower magnetic electrodes, the upper magnetic electrodes, the lower magnetic terminals and the upper magnetic terminals are cylindrical. It is available to adopt commercially available finished-product magnetic electrodes, magnetic terminals, etc. The magnetic electrodes and magnetic power supply terminals may also be fabricated by fixing (welding, for instance) formed green bodies of the magnetic electrodes and formed green bodies of the magnetic terminals onto a power circuit board or a control circuit board in advance, and then magnetizing.

**[0011]** According to the magnetically held diaper monitor of the present invention, a split design scheme is adopted to the power supply part, the control part and the diaper sensor. The power supply part and the control part between which the diaper sensor can be clamped conveniently are combined into a whole by attraction by means of a magnetic force of multiple pairs of symmetrically configured magnetic electrodes and magnetic terminals. Conductive connecting parts of the diaper sensor are tightly crimped by the multiple pairs of magnetic electrodes to realize reliable connection with a circuit of the control part. The control part obtains a direct-current power supply from the power supply part by the magnetic terminals which are in direct contact.

**[0012]** As an independent component, the power supply part can be recycled conveniently after the battery is exhausted; the control part having high cost can be reused to save the cost, and the disposable diaper sensor and the monitor are convenient to assemble and disassemble.

**[0013]** Because the power part and the control part are independent components, the button battery and the power circuit board are embedded and sealed in the lower shell through the insert injection molding process, and the control circuit board is embedded and sealed in the upper shell through the insert injection molding process, waterproof and moistureproof effects are achieved to facilitate to protect the circuit part and the battery and prolong the service life thereof.

## BRIEF DESCRIPTION OF THE DRAWINGS

### [0014]

5 Fig. 1 is a structural schematic drawing of one embodiment of the diaper monitor of the present invention, wherein a diaper sensor 3 is clamped between a power supply part 1 and a control part 2;

10 Fig. 2 is an exploded view of Fig. 1;

Figs. 3-5 are structural schematic drawings of the power supply part 1 in Fig. 1, wherein Fig. 3 is a stereogram, Fig. 4 is a front view, and Fig. 5 is a side view; and

15 Figs. 6-9 are structural schematic drawings of the control part 2 in Fig. 1, wherein Fig. 6 is a stereogram, Fig. 7 is a front view, Fig. 8 is a side view, and Fig. 9 is a vertical view.

## DETAILED DESCRIPTION OF THE PREFERRED EMBODIMENTS

25 **[0015]** The present invention will be further illustrated below in conjunction with the drawings and embodiments.

**[0016]** Referring to Fig. 1 and Fig. 2, the magnetically held diaper monitor of this embodiment mainly comprises a control part 2 and a power supply part 1. A split design is adopted to the control part 2, the power supply part 1 and a diaper sensor 3 capable of being attached to a diaper, wherein the power supply part 1 and the control part 2 between which a diaper sensor 3 can be clamped tightly are combined into a whole by attraction by means of an appropriate magnetic force via symmetrically configured magnetic electrodes and magnetic terminals; in addition, conductive connecting parts of the diaper sensor 3 are tightly crimped by the symmetrically configured magnetic electrodes to realize reliable connection with a circuit of the control part, and the control part 2 obtains a direct-current power supply from the power supply part 1 via direct contact among the symmetrically configured magnetic terminals.

30 **[0017]** Figs. 3-5 are structural schematic drawings of the power supply part 1. The power supply part 1 comprises a lower shell 11 having two positioning blind holes 112 and 114, a power circuit board 12 and a button battery 13; the power circuit board 12 and the button battery 13 are embedded in the lower shell 11 through an insert injection molding process, and the button battery 13 is located on the back of the power circuit board 12 and is welded to a printed power line on the power circuit board 12.

35 **[0018]** Three lower magnetic electrodes 121, 123 and 125 are arranged at the left end of the power circuit board 12, and two lower magnetic terminals 126 and 127 are welded to the upper edge of the power circuit board 12.

The lower magnetic terminals and the lower magnetic electrodes penetrate out of a surface, where the positioning blind holes are located, of the lower shell 11, wherein all the penetrating ends are N poles. In Figs. 3-5, the positioning blind hole 112 is located between the lower magnetic electrodes 121 and 123, and the positioning blind hole 114 is located between the lower magnetic electrodes 123 and 125. The two positioning blind holes 112 and 114 are asymmetrically configured to distinguish the front surface and the back surface of the diaper sensor. The lower magnetic terminals 126 and 127 are welded to a positive output end and a negative output end of the printed power line on the power circuit board 12 respectively.

**[0019]** Figs. 6-9 are structural schematic drawings of the control part 2. The control part 2 comprises an upper shell 21 having two positioning pins 212 and 214, and a control circuit board 22 embedded in the upper shell 21 through an insert injection molding process. Upper magnetic electrodes 221, 223 and 225 which are in one-to-one correspondence to the lower magnetic electrodes 121, 123 and 125 and two upper magnetic terminals 226 and 227 which correspond to the two lower magnetic terminals 126 and 127 are arranged at one end, corresponding to the power circuit board 12, of the control circuit board 22. The upper magnetic terminals and the upper magnetic electrodes penetrate out of a surface, where the positioning pins (212 and 214) are located, of the upper shell 21, wherein all the penetrating ends are S poles. The two positioning pins 212 and 214 are also asymmetrically arranged, correspond to the two positioning blind holes 112 and 114 in the lower shell 11 respectively in position and are used for assembling and positioning the power supply part 1, the diaper sensor 3 and the control part 2 to ensure that the diaper sensor 3 is assembled at the correct side.

**[0020]** The upper magnetic terminals 226 and 227 are welded to a positive output end and a negative output end of the printed power line on the control circuit board 22 respectively. Here, the upper magnetic terminals 226 and 227 and the lower magnetic terminals 126 and 127 are combined by attraction by means of an appropriate magnetic force and directly contact to play a role of magnetizing a power supply switch, and the direct-current power supply of the power supply part 1 is connected to the control circuit board 22.

**[0021]** A new design or a traditional control circuit may also be available for the control circuit part with the control circuit board 22 as a carrier. The control circuit comprises a MCU, a detection unit connected to an input end of the MCU, a monitoring circuit connected to an output end of the MCU, etc. After a signal from the diaper sensor 3 is processed by the detection unit, the MCU judges whether a wearer has urinated or defecated and distinguishes feces from urine. The upper magnetic electrodes 221, 223 and 225 are respectively welded to three sensor signal input ends arranged on the control circuit board 22, and these sensor signal input ends are connected with

an input of the detection unit.

**[0022]** When the power supply part 1, the diaper sensor 3 and the control part 2 are combined into a whole by attraction by means of the magnetic force, conductive connecting parts 31, 33 and 35 of the diaper sensor 3 (referring to Fig. 2) are tightly crimped by three groups of corresponding magnetic electrodes (namely the upper magnetic electrode 221 and the lower magnetic electrode 121, the upper magnetic electrode 223 and the lower magnetic electrode 123, and the upper magnetic electrode 225 and the lower magnetic electrode 125) respectively, such that reliable connection between the diaper sensor 3 and the input end of the detection unit is realized via the upper magnetic electrodes 221, 223 and 225.

**[0023]** For convenience in use, a lower through hole 15 may be arranged at one corner, away from the lower magnetic electrodes, of the lower shell 11; an upper through hole 25 which corresponds to the lower through hole 15 may be arranged at one corner, away from the upper magnetic electrodes, of the upper shell 21; a lacing 4 is threaded into the lower through hole and the upper through hole, such that the power supply part 1 and the control part 2 are combined into whole to avoid a baby from eating by mistake. The power supply part 1 can be replaced conveniently after the electric quantity is exhausted, by means of the connection of the lacing 4. A rope ring may also be arranged on the power supply part 1 and the control part 2 respectively to facilitate connection.

**[0024]** Referring to Fig. 2 and Fig. 1 for assembly of the product, positioning holes 32 and 34 in a connecting end of the diaper sensor 3 are aligned to positioning blind holes 112 and 114 (the power supply part 1) in the lower shell 11, such that the positioning pins 212 and 214 (the control part 1) on the upper shell 21 penetrate through the positioning holes 32 and 34 and inserted into the positioning blind holes to be positioned. The power supply part 1, the diaper sensor 3 and the control part 2 are combined into a whole by attraction by means of the magnetic force. The power supply part 1, the diaper sensor 3 and the control part 2 are at a combined state (Fig. 1), and conductive connecting parts 31, 33 and 35 of the diaper sensor 3 are tightly crimped by the three groups of magnetic electrodes respectively, and reliable connection between the diaper sensor 3 and the input end of the detection unit is realized via the upper magnetic electrodes 221, 223 and 225. Meanwhile, the upper magnetic terminals 226 and 227 and the lower magnetic terminals 126 and 127 are combined by attraction by means of a magnetic force and directly contact, and the direct-current power supply of the power supply part 1 is connected to the control circuit board 22.

**[0025]** When there is a need to disassemble the diaper sensor 3, an external force is applied to overcome an attractive magnetic force between the upper and lower magnetic electrodes and between the upper and lower magnetic terminals, such that the power supply part 1 and the control part 2 are separated quickly to replace

the diaper sensor 3.

**[0026]** The monitor may be in use with a flexible diaper sensor having a cloth substrate or a paper substrate, etc. The structure, principle and use of the diaper sensor may refer to the patent description (No. CN201520516761.2). The diaper sensor should have three detection electrodes preferably to detect whether a wearer has urinated or defecated and distinguish feces from urine.

**[0027]** In the monitor, the lower magnetic electrodes, the lower magnetic terminals, the upper magnetic electrodes and the upper magnetic terminals are made from a magnetizable conducting material, for example, Nd-FeB, etc. Duration implementation, the magnetic electrodes and the magnetic power supply terminals may also be fabricated by fixing (welding, for instance) formed green bodies of the magnetic electrodes and formed green bodies of the magnetic terminals to a power circuit board or a control circuit board in advance, and then magnetizing.

#### Reference numbers

#### [0028]

11	lower shell	25
112 and 114	positioning blind holes	
12	power circuit board	
13	button battery	
121, 123 and 125	lower magnetic electrodes	
126 and 127	lower magnetic terminals	30
21	upper shell	
212 and 214	positioning pins	
22	control circuit board	
221, 223 and 225	upper magnetic electrodes	
226 and 227	upper magnetic terminals	35
31, 33 and 35	conductive connecting parts	
15	lower through hole	
25	upper through hole	25
4	lacing	
32 and 34	positioning holes	40

#### Claims

1. A magnetically held diaper monitor, comprising a control part; wherein the magnetically held diaper monitor further comprises:

a power supply part which comprises a lower shell (11) having two positioning blind holes (112, 114), a power circuit board (12) and a button battery (13) which are embedded in the lower shell (11), wherein a plurality of lower magnetic electrodes (121, 123, 125) and two lower magnetic terminals (126, 127) are arranged at one end of the power circuit board (12), and the lower magnetic terminals (126, 127) and the lower magnetic electrodes (121, 123, 125) penetrate

out of a surface, where positioning blind holes (112, 114) are located, of the lower shell (11); the control part comprises an upper shell (21) having two positioning pins (212, 214) and a control circuit board (22) embedded in the upper shell (21), wherein upper magnetic electrodes (221, 223, 225) which are in one-to-one correspondence to the lower magnetic electrodes (121, 123, 125) and two upper magnetic terminals (226, 227) which correspond to the two lower magnetic terminals (126, 127) are arranged at one end of the control circuit board (22), and the upper magnetic terminals (226, 227) and the upper magnetic electrodes (221, 223, 225) protrude out of a surface, where the positioning pins (212, 214) are located, of the upper shell (21); a diaper sensor is clamped between the power supply part and the control part which are combined into a whole by attraction via the lower magnetic electrodes (121, 123, 125), the lower magnetic terminals (126, 127) and the corresponding upper magnetic electrodes (221, 223, 225) and upper magnetic terminals (226, 227), the conductive connecting parts of the diaper sensor can be tightly crimped by the lower magnetic electrodes (121, 123, 125) and the upper magnetic electrodes (221, 223, 225) to realize reliable connection with the control circuit board (22), and the lower magnetic terminals (126, 127) directly contact the upper magnetic terminals (226, 227), such that the control circuit board (22) obtains a power supply from the power supply part.

2. The diaper monitor according to claim 1, wherein three lower magnetic electrodes (121, 123, 125) are arranged on the power circuit board (12); three upper magnetic electrodes (221, 223, 225) are arranged on the control circuit board (22).

3. The diaper monitor according to claim 1 or 2, wherein the power supply part, the diaper sensor and the control part are at a combined state, and the two positioning pins (212, 214) penetrating through positioning holes in the diaper sensor are inserted into the two positioning blind holes (112, 114) respectively.

4. The diaper monitor according to one of claims 1 to 3, wherein the power circuit board (12) and the button battery (13) are embedded in the lower shell (11) through an insert injection molding process; the control circuit board (22) is embedded into the upper shell (21) through an insert injection molding process.

5. The diaper monitor according to one of claims 1 to 4, wherein the lower magnetic electrodes (121, 123,

125) and the two lower magnetic terminals (126, 127) are formed by fixing formed green bodies onto the power circuit board (12) in advance and then magnetizing; the upper magnetic electrodes (221, 223, 225) and the two upper magnetic terminals (226, 227) are formed by fixing formed green bodies onto the control circuit board (22) in advance and then magnetizing.

6. The diaper monitor according to one of claims 1 to 5, wherein the lower magnetic electrodes (121, 123, 125), the lower magnetic terminals (126, 127), the upper magnetic electrodes (221, 223, 225) and the upper magnetic terminals (226, 227) are made from a magnetizable conducting material.
7. The diaper monitor according to one of claims 1 to 6, wherein the lower magnetic electrodes (121, 123, 125), the upper magnetic electrodes (221, 223, 225), the lower magnetic terminals (126, 127) and the upper magnetic terminals (226, 227) are cylindrical.
8. The diaper monitor according to one of claims 1 to 7, wherein a lower through hole (15) is arranged at one corner, away from the lower magnetic electrodes (121, 123, 125), of the lower shell (11); an upper through hole (25) which corresponds to the lower through hole (15), is arranged at one corner, away from the upper magnetic electrodes (221, 223, 225), of the upper shell (21).
9. The diaper monitor according to claim 8, wherein a lacing (4) is threaded into the lower through hole (15) and the upper through hole (25).

#### Patentansprüche

1. Ein magnetisch gehaltener Windelmonitor, der einen Steuerteil umfasst, wobei der magnetisch gehaltene Windelmonitor ferner folgendes umfasst:

einen Stromversorgungsteil, der ein unteres Gehäuse (11), das zwei Positioniersacklöcher (112, 114), eine Stromversorgungsplatine (12) und eine Knopfzelle (13) umfasst, die in das untere Gehäuse (11) eingebettet sind, wobei eine Vielzahl von unteren magnetischen Elektroden (121, 123, 125) und zwei untere magnetische Anschlüsse (126, 127) an einem Ende der Stromversorgungsplatine (12) angeordnet sind und die unteren magnetischen Anschlüsse (126, 127) sowie die unteren magnetischen Elektroden (121, 123, 125) dort durch eine Oberfläche des unteren Gehäuses (11) hinaustreten, wo sich die Positioniersacklöcher (112, 114) befinden; wobei der Steuerteil ein oberes Gehäuse (21)

umfasst, das zwei Positionierstifte (212, 214) und eine Steuerplatine (22) umfasst, die in das obere Gehäuse (21) eingebettet ist, wobei obere magnetische Elektroden (221, 223, 225), die einszu-eins zu den unteren magnetischen Elektroden (121, 123, 125) passen, und zwei obere magnetische Anschlüsse (226, 227), die zu den zwei unteren magnetischen Anschlüssen (126, 127) passen, an einem Ende der Steuerplatine (22) angeordnet sind und wobei die oberen magnetischen Anschlüsse (226, 227) und die oberen magnetischen Elektroden (221, 223, 225) dort von der Oberfläche des oberen Gehäuses (21) hervorragen, wo sich die Positionierstifte (212, 214) befinden;

wobei ein Windelsensor zwischen dem Stromversorgungsteil und dem Steuerteil eingeklemmt ist, die durch Anziehung über die unteren magnetischen Elektroden (121, 123, 125), die unteren magnetischen Anschlüsse (126, 127) und die entsprechenden oberen magnetischen Elektroden (221, 223, 225) und oberen magnetischen Anschlüsse (226, 227) zu einem Ganzen verbunden sind, wobei die leitenden Teile des Windelsensors durch die unteren magnetischen Elektroden (121, 123, 125) und die oberen magnetischen Elektroden (221, 223, 225) zusammengedrückt werden, um eine zuverlässige Verbindung mit der Steuerplatine (22) zu schaffen, und wobei die unteren magnetischen Anschlüsse (126, 127) in direktem Kontakt mit den oberen magnetischen Anschlüssen (226, 227) stehen, so dass die Steuerplatine (22) von dem Stromversorgungsteil mit Strom versorgt wird.

2. Der Windelmonitor gemäß Anspruch 1, wobei drei untere magnetische Elektroden (121, 123, 125) auf der Stromversorgungsplatine (12) angeordnet sind; wobei drei obere magnetische Elektroden (221, 223, 225) auf der Steuerplatine (22) angeordnet sind.
3. Der Windelmonitor gemäß Anspruch 1 oder 2, wobei der Stromversorgungsteil, der Windelsensor und der Steuerteil in einem verbundenen Zustand sind, und wobei die beiden Positionierstifte (212, 214), die durch die Positionierlöcher im Windelsensor hindurchtreten, entsprechend in die beiden Positioniersacklöchern (112, 114) eingesteckt sind.
4. Der Windelmonitor gemäß einem der Ansprüche 1 bis 3, wobei die Stromversorgungsplatine (12) und die Knopfzelle (13) durch ein Einlage-Spritzgussverfahren in das untere Gehäuse (11) eingebettet werden; wobei die Steuerplatine (22) durch ein Einlage-Spritzgussverfahren in das obere Gehäuse (21) eingebettet wird.

5. Der Windelmonitor gemäß einem der Ansprüche 1 bis 4, wobei die unteren magnetischen Elektroden (121, 123, 125) und die beiden unteren magnetischen Anschlüsse (126, 127) durch vorausgehendes Befestigen von Rohlingen auf der Stromversorgungsplatine (12) und anschließendes Magnetisieren gebildet werden; wobei die oberen magnetischen Elektroden (221, 223, 225) und die zwei oberen Anschlüsse (226, 227) durch vorausgehendes Befestigen von Rohlingen auf der Steuerplatine (22) und anschließendes Magnetisieren gebildet werden.
6. Der Windelmonitor gemäß einem der Ansprüche 1 bis 5, wobei die unteren magnetischen Elektroden (121, 123, 125), die unteren magnetischen Anschlüsse (126, 127), die oberen magnetischen Elektroden (221, 223, 225) und die oberen magnetischen Anschlüsse (226, 227) aus einem magnetisierbaren leitenden Material gefertigt sind.
7. Der Windelmonitor gemäß einem der Ansprüche 1 bis 6, wobei die unteren magnetischen Elektroden (121, 123, 125), die oberen magnetischen Elektroden (221, 223, 225), die unteren magnetischen Anschlüsse (126, 127) und die oberen magnetischen Anschlüsse (226, 227) zylindrisch sind.
8. Der Windelmonitor gemäß einem der Ansprüche 1 bis 7, wobei ein unteres Durchgangsloch (15) an einer von den unteren magnetischen Elektroden (121, 123, 125) entfernten Ecke des unteren Gehäuses (11) angeordnet ist; wobei ein oberes Durchgangsloch (25), das zum unteren Durchgangsloch (15) passt, an einer von den oberen magnetischen Elektroden (221, 223, 225) entfernten Ecke des oberen Gehäuses (21) angeordnet ist.
9. Der Windelmonitor gemäß Anspruch 8, wobei eine Litze (4) in das untere Durchgangsloch (25) und das obere Durchgangsloch (25) geschraubt ist.

## Revendications

1. Moniteur de couche-culotte maintenue par aimant, comprenant une partie de contrôle ; le moniteur de couche-culotte maintenue par aimant comprenant en outre :

une partie d'alimentation électrique qui comprend une coque inférieure (11) ayant deux trous borgnes de positionnement (112, 114), une carte de circuit imprimé d'alimentation en puissance (12) et une pile bouton (13) qui sont encastrés dans la coque inférieure (11), une pluralité d'électrodes magnétiques inférieures (121, 123, 125) et deux bornes magnétiques in-

férieures (126, 127) étant agencées à une extrémité de la carte de circuit imprimé d'alimentation en puissance (12) et les bornes magnétiques inférieures (126, 127) et les électrodes magnétiques inférieures (121, 123, 125) sortant au travers d'une surface de la coque inférieure (11) dans laquelle les trous borgnes de positionnement (112, 114) sont positionnés ;

la partie de contrôle comprend une coque supérieure (21) ayant deux broches de positionnement (212, 214) et une carte de circuit imprimé de contrôle (22) encastrée dans la coque supérieure (21), les électrodes magnétiques supérieures (221, 223, 225) en correspondance une à une avec les électrodes magnétiques inférieures (121, 123, 125) et les deux bornes magnétiques supérieures (226, 227) correspondant aux deux bornes magnétiques inférieures (126, 127) étant agencées à une extrémité de la carte de circuit imprimé de contrôle (22) et les bornes magnétiques supérieures (226, 227) et les électrodes magnétiques supérieures (221, 223, 225) ressortant hors d'une surface de la coque supérieure (21) dans laquelle les broches de positionnement (212, 214) sont positionnées ;

un capteur de couche-culotte est coincé entre la partie d'alimentation électrique et la partie de contrôle qui sont combinées en un tout par l'attraction via les électrodes magnétiques inférieures (121, 123, 125), les bornes magnétiques inférieures (126, 127) et les électrodes magnétiques supérieures (221, 223, 225) correspondantes et les bornes magnétiques supérieures (226, 227), les parties de liaison conductrices du capteur de couche-culotte pouvant être étroitement pincées par les électrodes magnétiques inférieures (121, 123, 125) et les électrodes magnétiques supérieures (221, 223, 225) pour réaliser une connexion fiable avec la carte de circuit imprimé de contrôle (22) et les bornes magnétiques inférieures (126, 127) entrant directement en contact avec les bornes magnétiques supérieures (226, 227), de telle sorte que la carte de circuit imprimé de contrôle (22) reçoive une alimentation électrique de la partie d'alimentation électrique.

2. Moniteur de couche-culotte selon la revendication 1, dans lequel: trois électrodes magnétiques inférieures (121, 123, 125) sont agencées sur la carte de circuit imprimé d'alimentation en puissance (12) ; trois électrodes magnétiques (221, 223, 225) supérieures sont agencées sur la carte de circuit imprimé de contrôle (22).
3. Moniteur de couche-culotte selon la revendication 1 ou 2, dans lequel la partie d'alimentation électrique,

- le capteur de couche-culotte et la partie de contrôle sont dans un état combiné et les deux broches de positionnement (212, 214) pénétrant à travers les trous de positionnement dans le capteur de couche-culotte sont respectivement insérés dans les deux trous borgnes de positionnement (112, 114). 5
4. Moniteur de couche-culotte selon l'une quelconque des revendications 1 à 3, dans lequel : la carte de circuit imprimé d'alimentation en puissance (12) et la pile bouton (13) sont encastrées dans la coque inférieure (11) par le biais d'un procédé de moulage par injection d'insert ; la carte de circuit imprimé de contrôle (22) est encastrée dans la coque supérieure (21) à travers un procédé de moulage par injection d'insert. 10 15
5. Moniteur de couche-culotte selon l'une quelconque des revendications 1 à 4, dans lequel les électrodes magnétiques inférieures (121, 123, 125) et les deux bornes magnétiques inférieures (126, 127) sont formées en fixant à l'avance des corps verts moulés sur la carte de circuit imprimé d'alimentation en puissance (12) puis en l'aimantant; les électrodes magnétiques supérieures (221, 223, 225) et les deux bornes magnétiques supérieures (226, 227) sont formées en fixant à l'avance des corps verts moulés sur la carte de circuit imprimé de contrôle (22) puis en les aimantant. 20 25 30
6. Moniteur de couche-culotte selon l'une quelconque des revendications 1 à 5, dans lequel les électrodes magnétiques inférieures (121, 123, 125), les bornes magnétiques inférieures (126, 127), les électrodes magnétiques supérieures (221, 223, 225) et les bornes magnétiques supérieures (226, 227) sont fabriquées à partir d'un matériau conducteur aimantable. 35
7. Moniteur de couche-culotte selon l'une quelconque des revendications 1 à 6, dans lequel les électrodes magnétiques inférieures (121, 123, 125), les électrodes magnétiques supérieures (221, 223, 225), les bornes magnétiques inférieures (126, 127) et les bornes magnétiques supérieures (226, 227) sont cylindriques. 40 45
8. Moniteur de couche-culotte selon l'une quelconque des revendications 1 à 7, dans lequel : un trou traversant inférieur (15) est agencé au niveau d'un coin de la coque inférieure (11) situé à l'écart des électrodes magnétiques inférieures (121, 123, 125) ; un trou traversant supérieur (25) qui correspond au trou traversant inférieur (25) est agencé au niveau d'un coin de la coque supérieure (21) situé à l'écart des électrodes magnétiques supérieures (221, 223, 225). 50 55
9. Moniteur de couche-culotte selon la revendication 8, dans lequel un lacet (4) est fileté dans le trou traversant inférieur (15) et le trou traversant supérieur (25).

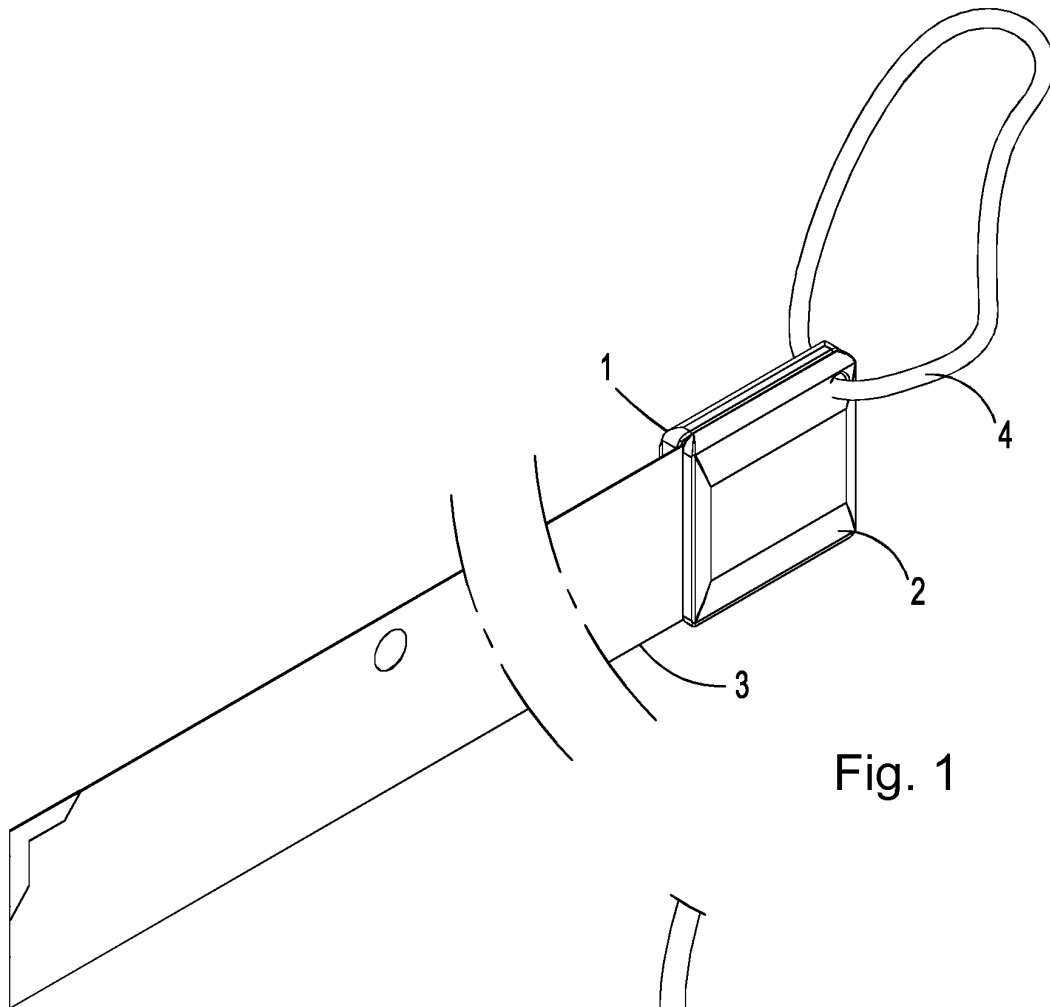

Fig. 1

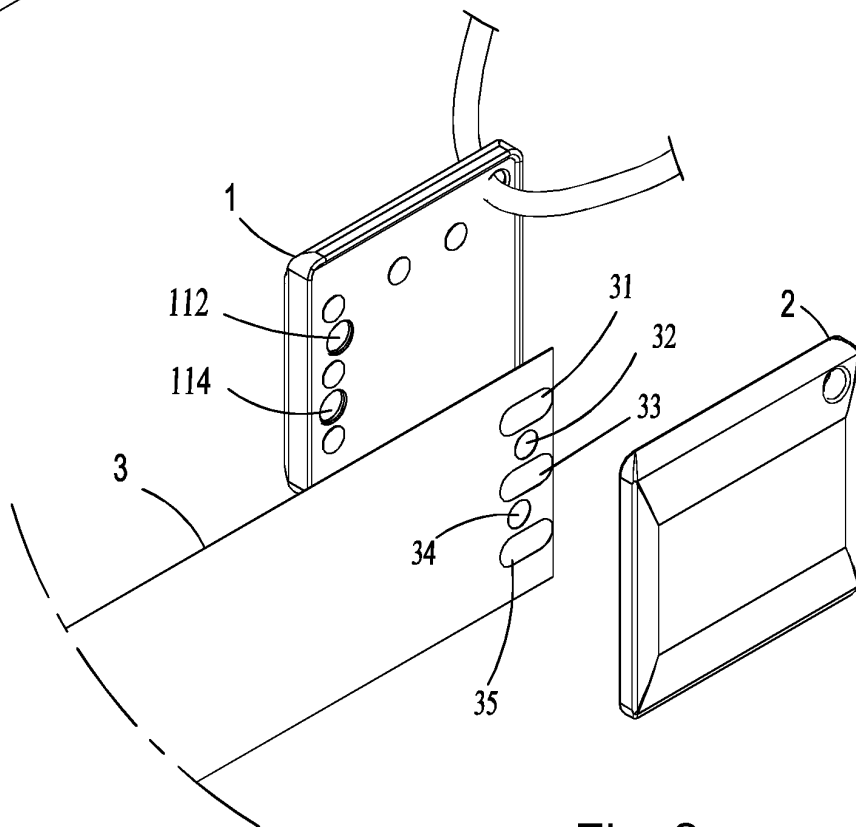

Fig. 2

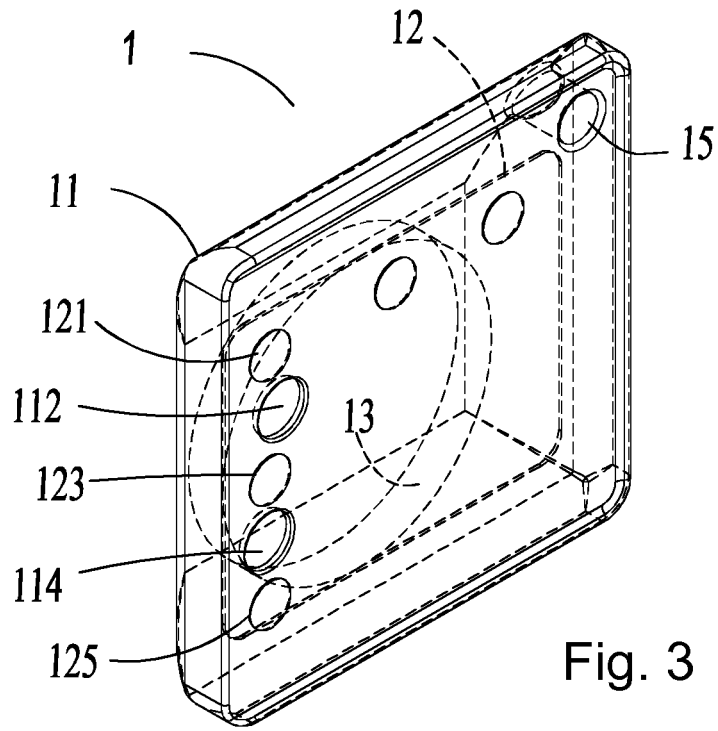

Fig. 3

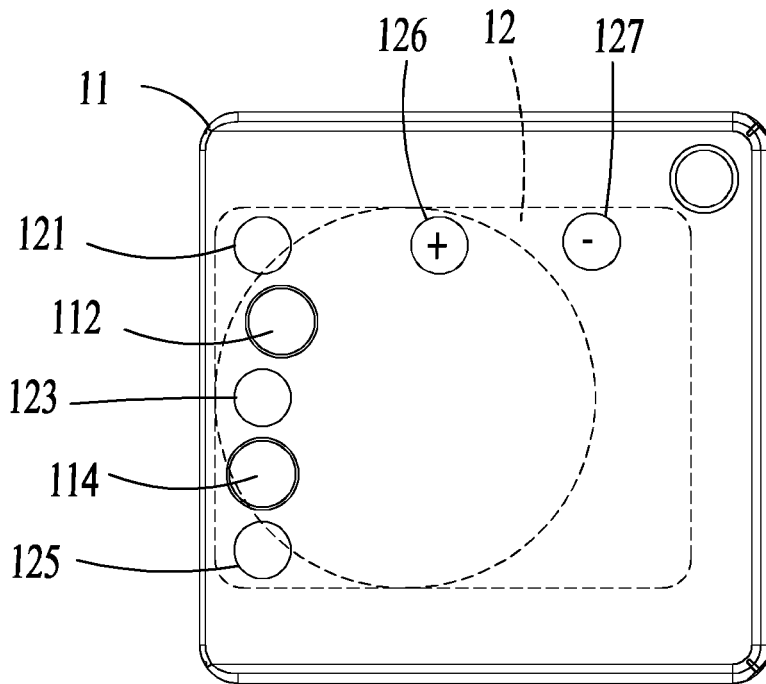

Fig. 4

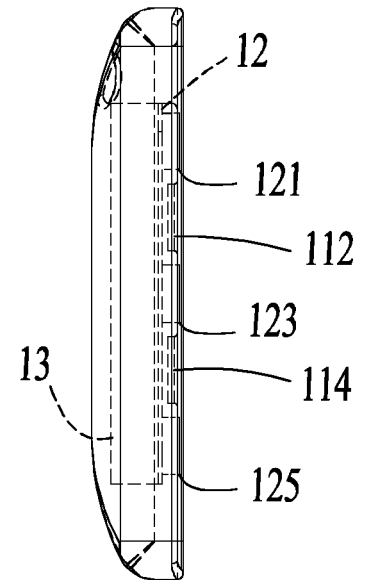

Fig. 5

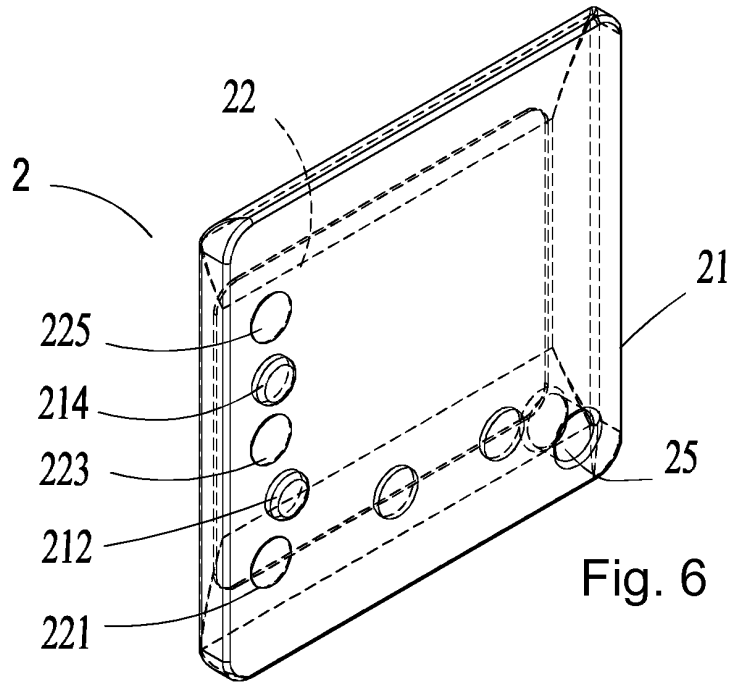

Fig. 6

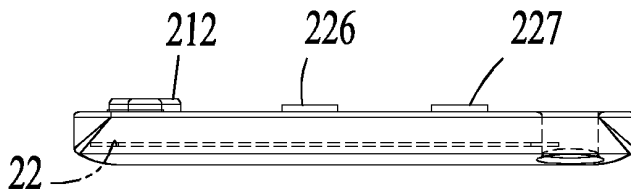

Fig. 9

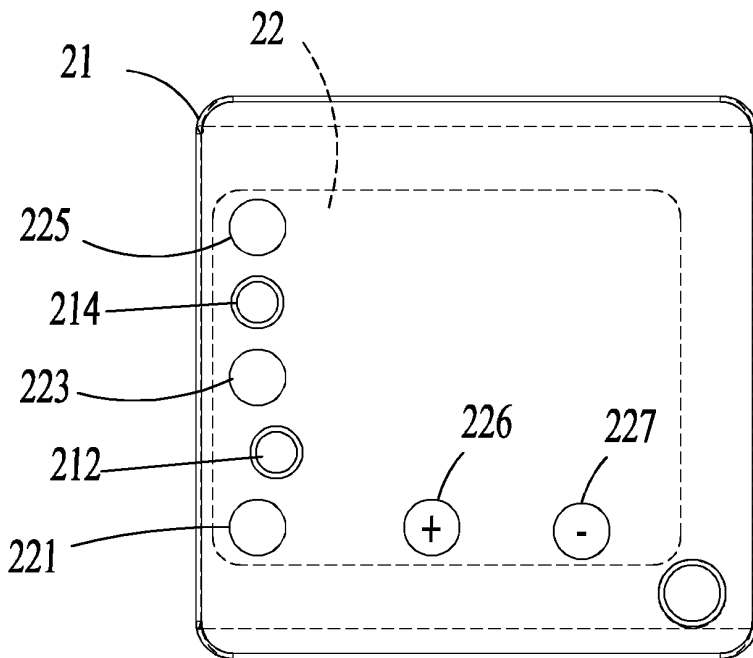

Fig. 7

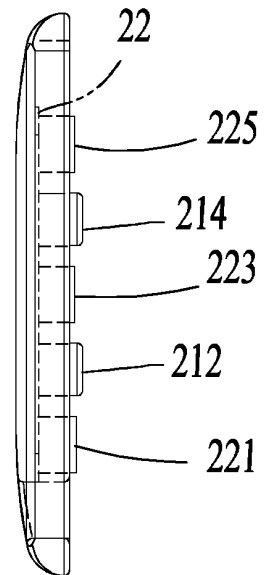

Fig. 8

**REFERENCES CITED IN THE DESCRIPTION**

*This list of references cited by the applicant is for the reader's convenience only. It does not form part of the European patent document. Even though great care has been taken in compiling the references, errors or omissions cannot be excluded and the EPO disclaims all liability in this regard.*

**Patent documents cited in the description**

- CN 201520516761 [0026]

专利名称(译)	磁控尿布监视器		
公开(公告)号	<a href="#">EP3241534B1</a>	公开(公告)日	2019-02-13
申请号	EP2016206763	申请日	2016-12-23
[标]申请(专利权)人(译)	深圳市华阳微电子有限公司		
申请(专利权)人(译)	深圳市HYAN微电子有限公司.		
当前申请(专利权)人(译)	深圳市HYAN微电子有限公司.		
[标]发明人	TENG YUJIE TENG YUDONG TENG DA		
发明人	TENG, YUJIE TENG, YUDONG TENG, DA		
IPC分类号	A61F13/42 A61B5/00 G08B21/20 A61F13/505 A61F13/84		
CPC分类号	H05K5/0047 A61B5/202 A61B5/6808 A61B5/6879 A61B2503/04 A61B2560/0204 A61B2562/225 A61F13/42 A61F13/505 A61F13/84 A61F2013/8479 A61F2013/8488 G01D11/30 H01R13/6205 H05K5/0217		
代理机构(译)	HELLMICH , WOLFGANG		
优先权	201610296882.X 2016-05-06 CN		
其他公开文献	EP3241534A1		
外部链接	<a href="#">Espacenet</a>		

摘要(译)

磁控尿布监视器包括电源部分和控制部分。电源部分包括下壳体，电池和嵌入下壳体中的电源电路板。电源电路板设有多个下磁电极和两个下磁电端子。控制部分包括上壳和嵌入上壳中的控制电路板。控制电路板设置有与下磁电极一一对应的上磁电极，以及与下磁电端子对应的上磁端子。尿布传感器夹在电源部分和控制部分之间，它们借助于磁力通过吸引力组合成一个整体，并通过磁电极连接到控制部分。控制部分通过磁性端子获得电源。

