

(19)



(11)

EP 3 125 747 B1

(12)

EUROPEAN PATENT SPECIFICATION

(45) Date of publication and mention of the grant of the patent:
22.04.2020 Bulletin 2020/17

(51) Int Cl.:
A61B 5/00 (2006.01) A61B 5/11 (2006.01)

(21) Application number: **15712945.3**

(86) International application number:
PCT/EP2015/057019

(22) Date of filing: **31.03.2015**

(87) International publication number:
WO 2015/150381 (08.10.2015 Gazette 2015/40)

(54) METHOD AND SYSTEM FOR AN ASSESSMENT OF A MOVEMENT OF A LIMB-RELATED POINT IN A PREDETERMINED 3D SPACE

VERFAHREN UND SYSTEM ZUR BEWERTUNG EINER BEWEGUNG EINES GLIEDMASSENBEZOGENEN PUNKTES IN EINEM VORBESTIMMTEN 3D-RAUM

PROCÉDÉ ET SYSTÈME POUR L'ÉVALUATION D'UN MOUVEMENT D'UN POINT ASSOCIÉ À UN MEMBRE DANS UN ESPACE 3D PRÉDÉTERMINÉ

(84) Designated Contracting States:
AL AT BE BG CH CY CZ DE DK EE ES FI FR GB GR HR HU IE IS IT LI LT LU LV MC MK MT NL NO PL PT RO RS SE SI SK SM TR

• **FISCH, Peter**
8634 Hombrechtikon (CH)

(30) Priority: **31.03.2014 EP 14162652**

(74) Representative: **Liebetanz, Michael**
Isler & Pedrazzini AG
Giesshübelstrasse 45
Postfach 1772
8027 Zürich (CH)

(43) Date of publication of application:
08.02.2017 Bulletin 2017/06

(73) Proprietor: **Hocoma AG**
8604 Volketswil (CH)

(56) References cited:
EP-A1- 2 660 742 WO-A1-2011/004403
CN-A- 103 315 744 CN-A- 103 598 889
US-A1- 2013 171 601

(72) Inventors:
• **HÖVER, Raphael**
8050 Zürich (CH)

EP 3 125 747 B1

Note: Within nine months of the publication of the mention of the grant of the European patent in the European Patent Bulletin, any person may give notice to the European Patent Office of opposition to that patent, in accordance with the Implementing Regulations. Notice of opposition shall not be deemed to have been filed until the opposition fee has been paid. (Art. 99(1) European Patent Convention).

Description

TECHNICAL FIELD

5 **[0001]** The present invention relates to a method and a system for an assessment of a movement of a limb-related point in a predetermined 3D space.

PRIOR ART

10 **[0002]** Gregorij Kurillo, Jay J. Han, Richard T. Abresch, Alina Nicorici, Posu Yan and Ruzena Bajcsy have published the article "Development and Application of Stereo Camera-Based Upper Extremity Workspace Evaluation in Patients with Neuromuscular Diseases" on PLOS ONE (Volume 7, Issue 9, e45341, www.plosone.org) (17.09.2012), disclosing a stereo camera-based reachable workspace analysis system which is capable of distinguishing individuals with varying degrees of proximal upper limb functional impairments. Prescribed movements are performed along a workspace envelope. The user is guided by a therapist what movements to do. The results are used to derive sphere segments as a model-based assumption. The disclosed stereo camera-based reachable workspace acquisition system combined with customized 3D workspace analysis algorithm was compared against a sub-millimeter motion capture system. The stereo camera-based system was robust, with minimal loss of data points, and with the average hand trajectory error of about 40 mm, which resulted to about 5% error of the total arm distance. For a number of persons, the workspace envelope surface areas generated from the 3D hand trajectory captured by the stereo camera were compared. Normalization of acquired reachable workspace surface areas to the surface area of the unit hemi-sphere allowed comparison between subjects. The healthy group's relative surface areas were about 0.618 and 0.552, for the right and left arm, respectively, while the surface areas for the individuals with neuromuscular diseases ranged from 0.03 and 0.09 (the most severely affected individual) to 0.62 and 0.50 (very mildly affected individual), for the right and left arm, respectively. Neuromuscular patients with severe arm weakness demonstrated movement largely limited to the ipsilateral lower quadrant of their reachable workspace.

25 **[0003]** The findings indicate that the proposed stereo camera-based reachable workspace analysis system is capable of distinguishing individuals with varying degrees of proximal upper limb functional impairments. The method to intuitively display and effectively analyze reachable workspace complements traditional upper limb functional assessments and allows quantifying and monitoring upper limb functions.

30 **[0004]** Claudia Rudhe, Urs Albisser, Michelle L Starkey, Armin Curt and Marc Bolliger have published the article "Reliability of movement workspace measurements in a passive arm orthosis used in spinal cord injury rehabilitation" in Journal of NeuroEngineering and Rehabilitation 2012, 9; 37 (<http://www.jneuroengrehab.com/>) (09.06.2012). The arm of the user is moved to specific points in the reachable workspace to calibrate a model that approximates the workspace geometry (box, ellipsoid, etc.). As robotic and non-robotic training devices are increasingly being used in the rehabilitation of upper limb function in subjects with neurological disorders, the article provides an evaluation of the reliability of movement measures as assessed with an ArmeoSpring system (provided by Hocoma AG, Switzerland) for the application to the rehabilitation of patients suffering from cervical spinal cord injury (SCI).

35 **[0005]** Reliability (intra- and inter-rater reliability) of the movement workspace (representing multiple ranges of movement) and the influence of varying seating conditions (5 different chair conditions) was assessed in twenty control subjects. In eight patients with cervical SCI the test-retest reliability (tested twice on the same day by the same rater) was assessed as well as a correlation of the movement workspace to retrieve self-care items as scored by the spinal cord independence measure (SCIM 3). Although the used movement workspace in the tested device has the shape of a cube instead of the anatomical spherical shape the findings were found to be related to clinical outcomes. The workspace volume was calculated from the data provided by the Armeo device and be followed over time to document changes during the course of rehabilitation.

40 **[0006]** The movement workspace is a multiple joint measure and does not assess the maximal shoulder movement capacity in a single direction as assessed in a single joint range-of-motion measurement. However, the reliability information from this more functional movement seems to be very good compared to, for example, single joint goniometry measurements of the shoulder. Reliability studies for goniometry measurements in the shoulder have a large intra- and inter-rater variability in results.

45 **[0007]** Klopčar N, Tomsic M and Lenarcic J have published the article "A kinematic model of the shoulder complex to evaluate the arm-reachable workspace." in J Biomech 2005, 40:86-91. Said article discloses, especially in its figures 10 and 11 and the relating description, the computed reachable workspace of the arm movement of a user.

50 **[0008]** A general training apparatus and corresponding method performed using such a training apparatus can be found in EP 2 660 742 from the applicant, inter alia used as means of support to provide for physiotherapy of the back of a person Further similar devices are disclosed in US 2013/171601 and WO2011/004403.

SUMMARY OF THE INVENTION

5 **[0009]** The prior art provides a method of assessment of the mobility, especially the workspace, of a limb, especially an arm, of a person. Based on the prior art, it is an object of the present invention to improve the method, inter alia accuracy, providing a better assessment of the mobility. It is a further object to improve the data acquisition by providing an intuitive workflow and visualization of the area already swept by the limb.

10 **[0010]** The method for an assessment of a movement of a limb-related point in a predetermined 3D space effected by a user displacing said limb in the 3D space comprises several steps. The displacement can happen around a joint or freely in the 3D space. The chosen limb of the user is provided with a limb position point connected to a predetermined portion of the limb which is associated to the limb-related point. The user is positioned in a measurement environment, comprising a computer having a processor, memory and a computer program to execute several steps of the method, a sensor arrangement adapted to detect movement of the limb position point within the predetermined 3D space and being connected to the computer and one or more display surfaces being connected to the computer. The user is positioned in front of one or more display surfaces around the 3D space, possibly between the display surfaces. The user position can be explicitly defined or it can only be the end effector which is taken into account. The chosen limb of the user, e.g. the entire arm, is provided with a limb position point connected to a predetermined portion of the limb which is associated to the limb-related point. When the chosen limb is the entire arm, the limb-related point may be the hand which is to be moved in the 3D space; and the limb position point may be an element allowing to identify the position of this point in relation to the hand which can be the limb position point. The computer is connected with sensors adapted to detect the position of the limb position point in the 3D space itself or in relation to the joint, the user is prompted to move the limb while, based on the acquired data from the sensor arrangement and the relation of the positions of the limb position point and the limb-related point, the computer program is adapted to calculate and store the position of the limb-related point in the 3D space and a 2+1D representation of the 3D space and to provide a representation of the position of the limb-related point on one of the display surfaces based on the 2+1D representation. This step of the method may be repeated using different 2+1D representations and different (2D) display surfaces in order to obtain a better accuracy of the assessment of the mobility in the 3D space. In a further step the computer may be adapted to calculate a consistent representation of the 3D workspace from the data stored in the previous steps. In a further step the computer may be adapted to calculate a representation of a 3D workspace that is a subset of the measured workspace in terms of removing a shell such that the points in this workspace are more easily reachable for the user, or a representation of a 3D workspace that is larger than the measured 3D workspace by adding a shell region such that the points in this workspace are more difficult to reach for the user.

25 **[0011]** The computer can also store the direction defined by the straight line between the joint, which is in the explanation of this paragraph the shoulder, and the end effector position. This is in the 3D space a function of the distance from said joint and thus from the local z-coordinate or in other words a distance on that line.

30 **[0012]** In fact, the calculating step, using the computer program adapted thereto, determines a value of a first function of the position of the limb-related point, and the representation of the position of the limb-related point in the 3D space as a second function of said value of the first function of the position of the limb-related point on one of the display surfaces. The description revert to two embodiments, wherein in one embodiment the first function relates to Cartesian 2D coordinates and the second function is a distance from a plane determined by this first function plane. It is noted that the plane is not necessarily flat. In the other embodiment described here the first function relates to a direction starting from a central point as a joint of the user and the second function is the distance of the limb point from the originating point. Of course other functions can be chosen to obtain the same result with the only prerequisite that the first function defines a specific position/orientation of the limb point and the second function allows an assessment of the movement of said limb point by the user.

35 **[0013]** The intuitive visualization of the assessment of the 3D workspace is supported by providing a real-world task to prompt the user, e.g. painting of a wall in a room with a brush. Therefore a user or patient intuitively knows what to do. The representation on the display surface comprises spots that are placed at a 2D location based on the 2D component of the 2+1D representation of positions of the limb-related point that were obtained during this or previous steps of the method, while one or more visual properties of the spot, e.g. color, hue, brightness, opacity, is based on the 1D component of the 2+1D representation of positions of the limb-related point. In a simple embodiment, the 3D space may be a cube in front of the user, the 2+1D representation may result from parallel projection towards the back side of the cube, i.e. - when assuming a Cartesian coordinate system with the back wall parallel to the x-y plane - a limb-related point within the cube, the x- and y-coordinates constitute the 2D part of the 2+1D representation, while the z-coordinate constitutes the 1D part of the 2+1D representation. Worded differently, when the user positions the limb such that the limb-related point is at a certain (x,y,z) position, a spot is displayed at a location corresponding to (x,y) on the display surface with a color hue corresponding to (z). As the assessment of mobility requires the user to reach as far as possible towards the back wall the spot is repainted when the limb-related point assumes the same (x,y) position at a later time during the assessment with a (z) component closer to the back wall. Because the limb-related point may not assume all positions

during one assessment certain locations on the display surface may not be painted with a spot. The spot has a finite size corresponding to a desired accuracy for the method, e.g. between 5 and 50mm, typically 20mm for assessment of the hand workspace.

[0014] A further advantage of the method according to the invention is due to the fact that the representation of the 3D area already swept by the arm is easily understandable on a 2D display surface, especially on a plurality of 2D computer screen providing a display surfaces representing the 3D space. The representation comprises colored spots on walls. The opacity of color hue indicates the depth, i.e. the reach of the arm-function. This avoids the visualization of complex 3D structures.

[0015] The invention is not restricted to cubic 3D spaces and parallel projection onto the cube's sides. For example, the 3D space may be any simply connected region of three dimensional space, the projection may use any plane in three dimensional space with an orthogonal or inclined vector along which the third coordinate is measured. Also non-linear and curved mapping of the 3D space to 3 coordinates is possible, esp. including polar or spherical coordinates.

[0016] The method according to the invention can be applied for any limb and for a plurality of position measurements.

[0017] If performing multiple measurement steps, each provides a part of the workspace boundaries in the form of a usually curved, finite 2D surface in the 3D space. In an additional step these surface parts can be merged together. In an alternative approach all positions of the limb-related point that were assumed during the measurement step(s) are pooled and the computer is adapted to calculate the hull of this cloud using standard mathematical methods.

[0018] The advantage of the method is inter alia that it is a purely data-driven approach without the need of using shape primitives like boxes or spheres of the workspace. Each (x,y) position or direction of the limb of the user is associated to a specific surface portion of one of the 2D screens thus representing the real person's workspace with high accuracy.

[0019] The use of different thresholds to show the possibilities of movement of a user in a specific direction is similar to start with a constrained bubble or sphere at the minimal distance around the shoulder. Then, when the user is pushing his arm in any specific direction and is going beyond the initial threshold being synonym to a white (or black) background, the color of the screen changes at that spot becoming darker (lighter) or a different color depending on the distance between shoulder and hand achieved. The same function can be achieved, if the position of the spot on the display screen is only related to the x,y position of the end-effector and the z position, i.e. the distance to the display screen or another relevant level or section parallel to the screen, would enable that the spot becomes darker (lighter) or a different color depending on the distance between the hand and a reference level.

[0020] Time effort for the assessment is tuned by selecting different "brush diameters" or nozzle spray areas, which can be visibly or invisibly represented by the border of the surface portion. This is equivalent to trade usability and speed against accuracy to optimize clinical use. Said larger brush areas can also be applied within one single assessment to different directions to provide a more exact assessment for the front region and to provide a less exact assessment for the top or bottom areas.

[0021] A challenge level can be introduced in any exercise by a single parameter value. Most commonly, exercises provide targets that the user has to move to within a workspace, in this case the workspace provided by the method. Any threshold value can be multiplied by e.g. 110%, 120% etc. thus inflating the initial bubble which has to be reached in order to obtain a reaction as a spot on the screen at the beginning and also in order to define the best (=darkest or lightest) color change when the user reaches the highest threshold level which is equivalent to the greatest distance achieved between shoulder and hand. The workspace can be enlarged by including part of the 3D space of a form of a shell around the measured workspace. Similarly the workspace can be shrunk by excluding a shell of the measured workspace. Enlarging the workspace leads to a higher challenge level because targets outside of the workspace that was reached during the measurement have to be reached during the exercise. In contrast, with a shrunk workspace the challenge level is smaller because less distant targets have to be reached.

[0022] Beside using a threshold, blowing up or shrinking the workspace can be done using a signed distance function. This avoids the need of a reference point from which the scaling is performed. Here the scattered surface points in the 3D space obtained through a training surface are used to generate a signed distance function. Therefore, all points reached by the user can be described as $SDF(x)=0$. When using the same visualization for training, a training effect can be obtained by choosing the threshold for a specific colour or hue as $SDF(x) = 0.01$ meter, i.e. the subject has to move another 1 centimeter beyond the previous workspace to obtain the same colour intensity as in the first run. Further details are explained in the article "Reconstruction and Representation of 3D Objects with Radial Basis Functions" by J.C.Carr et al. retrievable under <http://www.cs.jhu.edu/~misha/Fall05/Papers/carr01.pdf>.

[0023] Besides providing a blank surface and to allow the user to reach every direction, it is possible to associate a defined workspace for the user, which he is supposed to reach. In such a scenario all areas outside such a region are not part of the assessment. Such regions can be defined by physical limits, e.g. if the user is at a specific position in the work space, he can only move his hand (and the end effector to a specific extent to his left and right (x,y position) depending inter alia on arm's length. Therefore defining areas "out of bounds" avoids frustration of the user in view of not reachable regions.

[0024] A method to effect a training session based on the data gathering as explained above can be part of a training method according to the invention, where the control unit uses the work space to define valid testing points inside the 3D working space and to exclude points which cannot be reached either by device limitations or user movement limitations.

[0025] Further embodiments of the invention are laid down in the dependent claims.

5

BRIEF DESCRIPTION OF THE DRAWINGS

[0026] Preferred embodiments of the invention are described in the following with reference to the drawings, which are for the purpose of illustrating the present preferred embodiments of the invention and not for the purpose of limiting the same. In the drawings,

10

Fig. 1 shows some walls of a display of surfaces of a 3D space, a brush and a painted spot on the front display,

Fig. 2 shows the walls of Fig. 1 with a further spot on the left display,

Fig. 3 shows the walls of Fig. 2 with a further spot on the right display,

15 Fig. 4 shows the walls of Fig. 3 with a further spot on the upper display and an explanation of the reachable workspace concept,

Fig. 5 shows the walls of Fig. 3 with a further spot on the lower display,

Fig. 6 shows a schematic representation of a user in front of one of the walls,

Fig. 7 shows a representation of parts of the system to perform the assessment, and

20 Fig. 8 shows a schematic representation of a view from above onto some walls of Fig. 1 with graphical representation of elements of the reachable workspace as a cross section view.

DESCRIPTION OF PREFERRED EMBODIMENTS

25 **[0027]** Fig. 1 shows five walls being displays or screens 100, i.e. hardware providing display surfaces 101, 102, 103, 104 and 105 of a display of surfaces 100 of a 3D space 110, a brush 45 and a painted spot 51 and 52 on the front display 105. Fig. 2 then shows the walls and display surfaces of Fig. 1 with a further spot 61 on the left display 101, Fig. 3 shows the walls and display surfaces of Fig. 2 with a further spot 62 on the right display 102, Fig. 4 shows the walls and display surfaces of Fig. 3 with a further spot 63 on the upper display 103 and Fig. 5 shows the walls and display surfaces of Fig. 4 with a further spot 64 on the lower display 104. The description of Fig. 1 to Fig. 5 will also take into account Fig. 6

30

showing a schematic representation of a user 10 in front of one of the walls and display surface, here the front display 105. **[0028]** The embodiment shown here relates to a method for an assessment of a movement of the hand 12 of an arm 15 with the limb-related point 32 in a predetermined 3D space 110 effected by the user displacing said arm 15 as limb in the 3D space 110 around the shoulder 11 (which can also only be the reference frame) as joint 31 allowing said

35

movement. Of course the limb 15 can also be the leg and the foot movement is contemplated. It can also be the head wherein the neck is the joint in question. It is also possible to look at parts of a limb as the underarm wherein the joint is the elbow and the hand movement in relation to the elbow is monitored. In other words, it can also relate to any moveable point with a reference frame fixed to a body part. **[0029]** User 10 is positioned within a 3D space 110. In the present embodiment the 3D space 110 is surrounded by

40

a display comprising one or more display surfaces 101 to 105 around the 3D space 110 around the user 10, especially positioned around the shoulder 11 as joint 31, Here five display surfaces are shown but it is also possible to close the box by providing a sixth screen behind the user to check its ability to move the arm behind its body, of course without turning the body. It is noted that the shoulder does not need to be inside the workspace. The backplane can be used to assess the back side of the users workspace which can have any location in the 3D space. **[0030]** The display surfaces can be computer screens or they can be silver screens with associated projectors. It is also possible to provide the display surfaces as virtual representations on glasses to be put in front of the eyes of the user providing the display surface. It is also possible to provide the display surfaces as regions on a computer screen, e.g. in front of the user.

45

[0031] Signal processing is provided by a computer comprising a processor, memory and one or more computer programs. The computer is adapted to send signals to either the screens, the projectors or to the display screen of the glasses for the visualization what will be explained in connection with Fig. 1 to 5.

50

[0032] Referring to Fig. 6, the user is provided with a hand transmitter 22 as limb position point connected to a predetermined portion of the hand 12 as limb 15 of the user 10 which is associated to the limb-related point 32. The hand transmitter 22 can also be an orthosis and forward kinematic.

55

[0033] The system is equipped with sensors adapted to detect the position of the hand transmitter 22 as limb position point in the 3D space 110; this can be in relation to the shoulder 11 as joint 31 but is not necessarily within such relationship. Since the positional relationship between the hand transmitter 22 and the hand 12 is known, the computer program is adapted to calculate the position of the limb - related point 32 (and joint 31, if necessary). In this context hand

12 is represented in the 3D space by the calculated values of limb - related point 32.

[0034] The position of the shoulder 11 in space can be obtained through different methods. When the Armeo device of Hocoma AG is used (as described in the paper from Claudia Rudhe mentioned in the introduction) then it is possible to calculate the position of the shoulder through its fixation in relation to the device. In an alternative embodiment a shoulder transmitter 21 can be provided so that the user 10 can stand freely in the 3D space 110. The upper body and including the shoulder 11 can also only be used as reference point in a x,y disposition of the method.

[0035] The hand transmitter 22 can be one or more lights positioned on the underarm 15 of the user 10 and well known motion capture technology is used to identify the position of the transmitter 22 in space. Within the framework of the present embodiment, knowledge of the position of the underarm is sufficient since it is in a specific distance to the hand as such. Since here, the movement possibilities of the entire arm 15 as limb are studied; the limb - related point 32 is "the hand" as such. The hand 12 of the user 10 can hold a handle as provided within the Armeo device of Hocoma AG which is represented as brush 45. Limb position point 22 can be determined to be in the middle of the palm of the hand of the user 10.

[0036] It is also possible to use the weight support device (as Armeo by Hocoma AG) and the related sensors in e.g. the joint angle sensors of the device or specific sensors of the device providing the knowledge of the position of said handle of the device in relationship to the limb-related point 32. Based on that it is clear for the person skilled in the art that a number of data acquisition possibilities exist to obtain the necessary 3D data, i.e. the position of the limb position point 32, reflecting the actual position of the hand 12 of the arm 15 in 3D space 110 and the position of the shoulder 11 from the shoulder transmitter 21 in the corresponding embodiments.

[0037] The computer program is then adapted either to calculate the direction defined by the straight line 30 between the joint 31 and the limb-related point 32 and to provide a representation of the position of the limb-related point 32 in the 3D space 110 as function of the distance 35 between said joint 31 and the limb-related point 32 on one of the display surface 100-105 on said line 30, or it is adapted either to calculate the position of the hand alone and to provide a representation of the position of the limb-related point 32 in the 3D space 110 as function of the z distance on one of the display surface 100-105.

[0038] Initially the result of said calculation is a distance value 35. This distance value 35 can be represented on the related screen surface 105 or it can be maintained as a value without visual representation. Within a different embodiment, the result of the calculation can be the z position of the end effector.

[0039] The computer can provide on the related screen surface 105 an associated visible surface portion 40 or it can be maintained invisible or only the surrounding line 41 is represented. At the center of the surface portion 40 is provided a preferably visible point 46. Said point is a cursor which can be a paint brush 45 as shown in Fig. 1 to 5 or e.g. a spray nozzle or any other visual representation for the user 10 to show him either the direction his arm 15 is pointed or the x, y position of the end effector. In other words the computer program is adapted to visualize the direction of the limb position point 32 seen from the joint 31 on the related surface 105 by the cursor 45 or 46 or visualizes the x,y position of the end effector in front of the related surface 105.

[0040] The (screen) surface, onto which the cursor is shown, as indicated in Fig. 1 to 5, may depend on the x,y,z position of the end-effector or of the direction of the line 30 or a selection of the user or a sequence defined in the workflow. In this direction are to be provided the one or more surfaces 100 to 105 around the 3D space 110 around the user to enable a representation. Preferably at least three planes are provided as the frontal plane 105, a left sagittal plane 101 and a right sagittal plane 102. In a preferred embodiment a top transversal plane 103 and a bottom transversal plane 104 are added and finally it is possible to have a back plane (not shown) so that these six planes are spanning a cube.

[0041] The computer program is adapted to determine and store in its memory one or more specific sizes of the surface portion 40. They can be associated to specific directions of the limb position point 32 seen from the joint 31 or they can be associated to specific x,y,z positions of the limb position point 32. In other words, the size of the surface portion 40 can be smaller in front of the user 10, when his arm 15 is directed towards the front screen 105, or the x,y position is such that the position of the effector is just in front of the person, and the size of the surface portion can be bigger, when his arm 15 is directed towards the top screen 103 or when the x,y position is detected such, that the position of the end-effector is high above the training person.

[0042] The assessment method of the invention starts from white screen surfaces 53 on screens 101 to 105. Beside white screen surfaces also any neutral color can be used. When the user 10 is then putting forth his hand and reaches out for the virtual wall in front of him the distance 35 between his shoulder 11 and his hand 12 increases and will reach a predetermined threshold distance. If the threshold is chosen 0, then the training person immediately starts painting. Then the computer program triggers the painting function of the brush 45 and colors the surface portion 40. It is then the task of the user to color, if possible the entire surface of the screens 101 to 105. This can only be achieved either if the distance 35 is greater than the said threshold, or if the distance "z" has a specific value. Of course it is also possible to start painting with a threshold / starting value of 0; then the training person immediately starts painting.

[0043] It is then clear that the size of the surface portion 40, i.e. the brush size, determines the possible speed of coverage of the screen and the necessary precision of the sweeping movement of the arm 15. A greater surface portion

40 necessitates less precision and allows a faster gathering of data.

[0044] The computer program can have stored different threshold distances for different directions. The same is true, if the position z is the basis for the painting action; then the colour resolution can be chosen different for specific x,y values, e.g. in front of the user compared to x,y values related to a positioning of the end effector on the far left or right side of the body of the training person. Directions which are more difficult to achieve can have a lower threshold value than more convenient directions. This can be combined with an array of threshold distances, i.e. that the computer program stores a number of threshold distance for any given direction. This can also be done by providing a first distance value and then determine further threshold values as 110%, 120%, 130% of this initial value and so on. When the user 10 then reaches out for the virtual wall in front of him and "pushes" the virtual brush "against the wall" the distance 35 between his shoulder 11 and his hand 12 increases further and eventually the user 10 will reach further of these predetermined threshold distances. Then preferably the computer program is adapted to change the hue or opacity of the colored spot if the distance 35 between joint 31 and limb position point 32 exceeds one of the further predetermined threshold distances. This is shown in Fig. 1 with two different surface areas. The inner area 51 around the brush 45 is a "darker" area whereas the outer area 52 is the "lighter" area, with the remaining not reached surface 53 remains white. Of course today screens allow for a high number of different color intensities or even different colors as e.g. used for temperature representation, e.g. a blue area 52 for a smaller distance 35 threshold and a red area 51 for a higher distance 35 threshold. In all these cases the function of representation of the distance 35 between the joint 31 and the limb position point 32 is the hue or opacity of the associated surface portion 40 of the surface on said straight line 30.

[0045] As explained, it is more intuitive for the user 10, if the function of representation is monotonously increasing or decreasing with said distance 35. The decreasing function can be used with a black screen at the beginning and any outreach of the arm 12 going beyond any one of the thresholds lightens up the screen surface towards grey and finally white, if the last threshold distance is reached.

[0046] The explained way of painting on the walls comprises already a further function of the computer program, i.e. any passage of the surface portion 40 over a specific screen portion is memorized, if the distance 35, i.e. the outreach of the arm 15, is greater than one of the memorized thresholds. Then this maximal value for the specific direction is retained. It is possible that the resolution of the position of the cursor 45 is higher than the resolution of the area covered by the surface portion, i.e. when the cursor 45 has a pixel resolution the area covered by the surface portion can have an approximate circle coverage of e.g. eleven pixel or twenty pixel, so that any further sweep of the user can also partly cover a former sweep area.

[0047] In order to assess the possibilities of the user 10, the computer is adapted to store in its memory the maximum or minimum value, respectively, of the hue or opacity of any of the associated surface portions 40 for the specific determined size, if the user sweeps more than once over the surface portions 40, either entirely or partly. It is also possible that only the maximum coordinate measured along the plane normal (local normal) is stored.

[0048] A challenge level can be introduced in any exercise by a single parameter value. This means that any threshold value is then multiplied by e.g. 110%, 120% etc. thus inflating the initial threshold bubble which has to be reached in order to obtain a reaction as a spot 52 on the screen at the beginning and also in order to define the best (=darkest or lightest) color change, e.g. spot 51, when the user reaches the highest threshold level which is equivalent to the greatest distance achieved between shoulder and hand.

[0049] Use of such a single parameter value within a multiplication can set the necessary threshold beyond the maximum reachable distance of the user, defined by his arm length. In such a case, the computer program software is preferably adapted to limit the inflation of workspace so that the inflated workspace always lie inside the device workspace or in other words, all points even in inflated work spaces are physically reachable.

[0050] On the other side, the minimum distance 35 to be reached as threshold defines the knowledge of the inner safety region, i.e. the region close to the body of the user 10 which is not to be assessed as assumptions about the location of the patient's body give sufficient information.

[0051] Within Fig. 4 is represented the concept of the reachable workspace. Besides providing a blank surface 53 as in Fig. 1 and to allow the user to reach every direction, it is possible to associate a defined delimited workspace 72 for the user 10, which he is supposed to reach starting from an already reached surface 71. Here, only one shading is used in an embodiment where the reaction of the system is "reached" or "not reached" which means that either the minimal threshold distance was reached at a given surface portion 40 or not. In such a scenario all areas 73 outside such a region 72 are not part of the assessment. They should be tainted in a different shade to clearly show the user 10 that he is not supposed to move the brush 45 and thus his arm 15 in this direction. This can be due to reasons within the framework of the exercise or simply, because the training device or the disposition of the user does not allow reaching such areas 73 outside the delimitation 72.

[0052] Artifacts due to rapid movements of the user 10 can be suppressed in the resulting workspace using low-pass filters. This is equivalent to the effect that the "paint" in the "brush" 46 is given a viscosity and is only applied (and thus checked) against the position data by the computer after a specific predetermined time, so that the user has to slowly sweep the cursor 45 over the wall to obtain the color or hue change.

[0053] Connected with the method is a system for the assessment of a movement of a limb-related point 32 in a predetermined 3D space 110 effected by a user displacing said limb 15 in the 3D space 110 around a joint 11 allowing said movement. Such a system as shown in the schematic representation of Fig. 7 comprises a computer 200 having a processor, memory 201, keyboard or input means 202 and a computer program running on that computer. The system further comprises one or more display surfaces 101 to 105 arranged around the 3D space 110 around the user 10, especially around the shoulder 11 in the present embodiment. A limb position sensor 122 is provided and adapted to receive via wireless or wire-bound transmittal means 222 position data relating to the limb position point 22 connected to a predetermined portion of the arm 15 of the user 10 which is associated to the hand as the limb-related point 32. A further joint sensor 121 is provided to receive position data related to the shoulder via wireless or wire-bound transmittal means 221, depending if a specific shoulder transmitter 21 is used or position data from a weight relief mechanism as Armeo are provided.

[0054] Then the computer program in computer 200 is adapted to calculate the direction defined by the straight line 30 between the shoulder 11 and the limb-related point 32 and control signals are generated and transmitted to the screens to provide a representation 45 of the position of the limb-related point 32 in the 3D space 110 as function of the distance 35 from said shoulder 11 on one of the display surface 101 to 105 on said line 30. The different thresholds as mentioned above can be entered via input means 202 and stored in memory 201. The same is true for different degrees of hue and opacity and the memorized sweeps of the user over the 2D surface of the screens 101 to 105.

[0055] Within another embodiment of the system for the assessment of a movement of a limb-related point 32 in a predetermined 3D space 110 effected by a user displacing said limb 15 in the 3D space 110 allowing said movement. Such a system as shown in the schematic representation of Fig. 7. The system further comprises one or more display surfaces 101 to 105 arranged around the 3D space 110 around the user 10. A limb position sensor 122 is provided and adapted to receive via wireless or wire-bound transmittal means 222 position data relating to the limb position point 22 connected to a predetermined portion of the arm 15 of the user 10 which is associated to the hand as the limb-related point 32. Then the sensors take x,y values of the position of the hand via the limb position point 22 to enable "painting" using the z value of the position of the hand in the 3D space.

[0056] Then the computer program in computer 200 is adapted to calculate the position of the limb-related point 32 and control signals are generated and transmitted to the screens to provide a representation 45 of the position of the limb-related point 32 in the 3D space 110 as function of the x,y, position and the z distance 35 from a specific section on one of the display surface 101 to 105. The different thresholds as mentioned above can be entered via input means 202 and stored in memory 201. The same is true for different degrees of hue and opacity and the memorized sweeps of the user over the 2D surface of the screens 101 to 105.

[0057] The mathematical concept starts with a position of the hand or limb-related point in the 3D space. Then two functions are used to map this 3D-vector value of the hand position into a 2D mapping usually mentioned as (x,y) and a 1D mapping onto (z) wherein the values (x,y) and (z) uniquely define the hand in the 3D space, i.e. the functions define a coordinate system. For each time during the assessment phase, for each spot (x,y), which is a region in the 2D space that is characterized by its position and a brush size, the (z) component is evaluated and stored as (zmax) if it is larger than previous stored (z) at this location. Of course, "larger" does not reduce the generality because the underlying function can be redefined. In order to do that a grid of (x,y) values is predefined, if an (x,y) is never reached during the assessment, its (zmax) is never changed from an initial value, which is different from values that can occur during measurement, e.g. NaN in computer implementations.

[0058] The visualisation displays the spot visually at pixel coordinates (a,b) on a display surface with (a,b) as function of (x,y) and colored according to a color index as function of (z). The initial or background color of the display surface is predetermined and chosen and is shown for z=NaN in above example. Therefore, if at a later time (z) at that time is larger than all (z) during this assessment phase, the corresponding spot is repainted with a new value, being a threshold criterion. On the other hand, if at a later time (a,b) are outside of all (a,b) previously encountered, this spot will be colored, being another threshold criterion.

[0059] Fig. 8 shows a schematic representation of a view from above onto some walls 101, 102 and 105 of Fig. 1 with graphical representation of elements of the reachable workspace as a cross section view. Front wall 105 is bordered by the left wall 101 as well as by the right wall 102. The user 10 is positioned below the two side walls 101 and 102 facing the front wall 105. In the initial steps as described with the representations of Fig. 1 to 5, the user 10 is moving his arm 15 with the virtual brush 45 to "paint" the different walls in front 105, on the right wall 102 as well as on the left wall 101. For the sake of simplicity and understanding, it is not contemplated that the user 10 is painting the bottom wall 104 or the upper wall 103 and Fig. 8 shows a cross section of the view from above e.g. at chest height.

[0060] The user 10 generates the representation 72 of the reachable workspace being a closed line 131, shown as dotted line, in the cross section; in other words, the 3D cloud based on 2D paintings as patient workspace has received the reference numeral 131. These values are generated by the user data. On the other side, the device also has its physical limitations, not allowing the user 10 to reach every point in space. These boundaries are not visible when the user strives to paint on opposite walls. But they are quite there, if the user 10 wants to paint in front of his chest; then

EP 3 125 747 B1

the mechanical parts of the training device will not allow his hand to reach towards an area and places in front of him.

[0061] Therefore, these parts are predetermined exceptions from the workspace and the reachable workspace, the 3D cloud after intersection with the device workspace, is referenced with numeral 132 as closed line. This reachable workspace 132 divides the space (here in the cross section the plane) in two parts. One part is "inside", where reference numeral 134 is related to a target in the reachable part of the workspace, i.e. the user 10 can use the brush 45 to reach this point in space. On the other side there are points 133 "outside" for a target not in the reachable part of the workspace through device limitation and also "outside" points 135 for a target not in the reachable part of the workspace for a specific user.

[0062] The method comprising the assessment steps as explained above can be followed by a testing step, comprising generating a first data set of boundaries 132 reachable by a system comprising said sensors 21, 22. Then inside the control unit a second data set of boundaries 131, reachable by the user based on the assessment steps, is created. Then the control unit calculates a third subset of test boundaries as intersection of the first data set with the second data set, to exclude not technically reachable points as points 133 or points 135 outside the subjective range of the user. Thus points 134 are defined which are inside said test boundaries as reachable points and the other points 133, 135 are defined to be outside said test boundaries as not-reachable points.

[0063] The training session then comprises providing a target point 134 as part of the subset of reachable points as virtual representation on the one or more display surfaces 101-105 around the 3D space 110 around the user 10 to be reached by the user 10 through movement of a limb position point 22 connected to a predetermined portion of the limb 15 of the user 10 which is associated to the limb-related point 32. If the user 10 is successful to reach the object target point, then he triggers a result event, and optionally the last mentioned two steps are repeated in such a training session with randomly or specifically changing target points 134, especially near the boundaries of reachable points, to push the limits of these boundaries. It is important that the intersection is used to reduce the 3D cloud of possible targets to the actually reachable target points in the stored 3D space.

LIST OF REFERENCE SIGNS

10	user	103	top wall
11	shoulder	104	bottom wall
12	hand	105	front wall
15	arm	110	3D space
21	shoulder transmitter	121	joint sensor
22	hand transmitter / limb position point	122	limb position sensor
30	connection line	131	3D cloud based on 2D paintings (patient workspace)
31	joint	132	3D cloud after intersection with device workspace
32	limb-related point	133	target not in the reachable part of the workspace through device limitation
40	surface portion		
41	surrounding line		
45	brush	134	target in the reachable part of the workspace
46	point		
51	dark area	135	target not in the reachable part of the workspace for a specific user
52	less dark area		
53	not painted area		
61	spot	200	computer
62	spot	201	memory
63	spot	202	input device
64	spot	221	joint sensor signal transmittal
65	spot	222	limb position sensor signal transmittal
71	reached area		
72	reachable work space		
73	out of bounds area		
100	3D space walls		
101	left wall		
102	right wall		

Claims

- 5
1. A method for an assessment of a movement of a limb-related point (32) in a predetermined 3D space (110) effected by a user displacing said limb (15) in the 3D space (110), comprising the steps of:
- 10
- providing a computer comprising a processor, memory and a computer program,
 providing one or more display surfaces (101-105) around the 3D space (110) around the user (10),
 providing a limb position point (22) connected to a predetermined portion of the limb (15) of the user (10) which is associated to the limb-related point (32),
 15 providing one or more sensors adapted to detect the position of the limb position point (22) in the 3D space in relation to a predetermined plane,
 calculating, using the computer program adapted thereto, a position (x,y) of the limb-related point in said plane being a value of a first function of the position of the limb-related point (32), and
 providing a representation of the position of the limb-related point (32) in the 3D space (110) being related to the distance (z) to that plane as a second function of said value on one of the display surfaces (100-105).
- 20
2. A method for an assessment of a movement of a limb-related point (32) in a predetermined 3D space (110) effected by a user displacing said limb (15) in the 3D space (110), wherein the movement of the limb-related point (32) is effected around a joint (31) allowing said movement, comprising the steps of:
- 25
- providing a computer comprising a processor, memory and a computer program,
 providing one or more display surfaces (101-105) around the 3D space (110) around the user (10),
 providing a limb position point (22) connected to a predetermined portion of the limb (15) of the user (10) which is associated to the limb-related point (32),
 30 providing one or more sensors adapted to detect the position of the limb position point (22) in the 3D space in relation to the joint (31),
 calculating, using the computer program adapted thereto, the direction defined by the straight line (30) between the joint (31) and the limb-related point (32) being a value of a first function of the position of the limb-related point (32),
 providing a representation of the position of the limb-related point (32) in the 3D space (110) being a function of the distance (35) on said line (30) between said joint (31) and the limb-related point (32) on one of the display surfaces (100-105) as a second function of said value on one of the display surfaces (100-105).
- 35
3. The method according to claim 1 or 2, wherein the one or more surfaces (100-105) around the 3D space (110) around the user (10) comprise three to six planes from the group comprising a frontal plane (105), a left sagittal plane (101), a right sagittal plane (102), a top transversal plane (103), a bottom transversal plane (104) and a back plane (100), especially spanning a cube.
- 40
4. The method according to any one of claims 1 to 3, wherein the computer program is adapted to visualize the value of the first function of the limb related point (32) on the related surface (100-105) by a cursor (45, 46), especially by a paint brush (45) or spray nozzle, on an associated visible or invisible surface portion (40).
- 45
5. The method according to claim 4, wherein the computer program is adapted to determine and store one or more specific sizes of the surface portion (40) associated to a specific value of the first function of the limb related point (32).
6. The method according to any one of claims 1 to 5, wherein the second function of representation of the limb related point (32) is the hue or opacity of the associated surface portion (40) of the surface (100-105).
- 50
7. The method according to claim 6, wherein the function of representation is monotonously increasing or decreasing with said value of the second function.
8. The method according to claim 6 or 7, wherein the computer program is adapted to change the hue or opacity if the value of the second function for the limb position point (32) exceeds one of one or more of predetermined thresholds.
- 55
9. The method according to claim 8, wherein the one or more predetermined thresholds are predefined and stored in the memory of the computer for a plurality of specific directions (30).
10. The method according to claim 8 or 9, wherein the computer is adapted to store in its memory the maximum and/or

the minimum value, respectively, of the hue or opacity of any of the associated surface portions (40) for the specific determined size, if the user sweeps more than once over the surface portions (40).

- 5 11. A system for an assessment of a movement of a limb-related point (32) in a predetermined 3D space (110) effected by a user displacing said limb (15) in the 3D space (110), comprising a computer (200) having a processor, memory (201) and a computer program, one or more display surfaces (100-105) arranged around the 3D space (110) around the user (10), a limb position sensor (122) adapted to receive (222) position data in the 3D space, in relation to a predetermined plane, relating to a limb position point (22), the limb position point connected to a predetermined portion of the limb (15) of the user (10) which is associated to the limb-related point (32), wherein the computer program is adapted to calculate a position (x, y) of the limb-related point in said plane being a value of a first function of the position of the limb-related point (32), and to provide a representation (45) of the position of the limb-related point (32) in the 3D space (110) being related to the distance (z) to said plane as a second function of said value on one of the display surfaces (100-105).
- 15 12. A system for an assessment of a movement of a limb-related point (32) in a predetermined 3D space (110) effected by a user displacing said limb (15) in the 3D space (110), comprising a computer (200) having a processor, memory (201) and a computer program, one or more display surfaces (100-105) arranged around the 3D space (110) around the user (10), a limb position sensor (122) adapted to receive (222) position data relating to a limb position point (22), the limb position point connected to a predetermined portion of the limb (15) of the user (10) which is associated to the limb-related point (32), further comprising a joint sensor (121) adapted to receive (221) position data related to the joint (31), wherein the computer program is adapted to calculate the direction defined by the straight line (30) between the joint (11) and the limb-related point (32) as a value of a first function of the position of the limb-related point (32) and to provide a representation (45) of the position of the limb-related point (32) in the 3D space (110) being a function of the distance (35) on said line (30) between said joint (31) and the limb-related point on one of the display surface (100-105) as a second function of said value on one of the display surfaces (100-105).
- 20 25 13. The method according to any of claims 1 to 11, wherein the assessment steps are followed by a testing step, comprising
generating a first data set of boundaries (132) reachable by a system comprising the sensors (21, 22)
30 generating a second data set of boundaries (131) reachable by the user based on the assessment steps
calculating a third subset of test boundaries as intersection of the first data set with the second data set,
defining points (134) inside said test boundaries as reachable points and defining points (133, 135) outside said test boundaries as not-reachable points,
providing a target point (134) as part of the subset of reachable points as virtual representation on the one or more display surfaces (101-105) around the 3D space (110) around the user (10) to be reached by the user (10) through
35 movement of a limb position point (22) connected to a predetermined portion of the limb (15) of the user (10) which is associated to the limb-related point (32), and
triggering a result event, when the user (10) reaches said target point (134) by movement of the limb.
- 40 14. The method according to claim 13, wherein the last two steps are repeated in a training session with randomly or specifically changing target points (134), especially near the boundaries of reachable points.

Patentansprüche

- 45 1. Verfahren zur Bewertung einer Bewegung eines Gliedmassen-bezogenen Punktes (32) in einem vorbestimmten 3D-Raum (110), die durch einen Benutzer bewirkt wird, der die besagte Gliedmasse (15) in dem 3D-Raum (110) bewegt, umfassend die folgenden Schritte:
- 50 Bereitstellen eines Computers mit einem Prozessor, einem Speicher und einem Computerprogramm,
Bereitstellung einer oder mehrerer Anzeigeflächen (101-105) um den 3D-Raum (110) um den Benutzer (10) herum,
Bereitstellen eines Gliedmassenpositionspunktes (22), der mit einem vorbestimmten Abschnitt der Gliedmasse (15) des Benutzers (10) verbunden ist, der mit dem Gliedmassen-bezogenen Punkt (32) verbunden ist,
55 Bereitstellung eines oder mehrerer Sensoren, die zur Erkennung der Position des Gliedmassenpositionspunktes (22) im 3D-Raum in Bezug auf eine vorbestimmte Ebene geeignet sind, Berechnung, unter Verwendung des daran angepassten Computerprogramms, einer Position (x,y) des Gliedmassen-bezogenen Punktes in der besagten Ebene als ein Wert einer ersten Funktion der Position des auf die Gliedmassen-bezogenen Punktes

(32), und

Bereitstellen einer Darstellung der Position des auf Gliedmassen-bezogenen Punktes (32) im 3D-Raum (110) als bezogen auf den Abstand (z) zu dieser Ebene als eine zweite Funktion des besagten Wertes auf einer der Anzeigeflächen (100-105).

5

2. Verfahren für eine Bewertung einer Bewegung eines Gliedmassen-bezogenen Punktes (32) in einem vorbestimmten 3D-Raum (110), die durch einen Benutzer bewirkt wird, der die Gliedmasse (15) in dem 3D-Raum (110) bewegt, wobei die Bewegung des Gliedmassen-bezogenen Punktes (32) um ein Gelenk (31) herum bewirkt wird, das diese Bewegung ermöglicht, umfassend die folgenden Schritte:

10

Bereitstellen eines Computers mit einem Prozessor, einem Speicher und einem Computerprogramm, Bereitstellung einer oder mehrerer Anzeigeflächen (101-105) um den 3D-Raum (110) um den Benutzer (10) herum,

15

Bereitstellen eines Gliedmassenpositionspunktes (22), der mit einem vorbestimmten Abschnitt der Gliedmasse (15) des Benutzers (10) verbunden ist, der mit dem Gliedmassen-bezogenen Punkt (32) verbunden ist, Bereitstellung eines oder mehrerer Sensoren, die die Position des Gliedmassenpositionspunktes (22) im 3D-Raum in Bezug auf das Gelenk (31) erfassen,

20

Berechnen, unter Verwendung des daran angepassten Computerprogramms, der durch die gerade Linie (30) zwischen dem Gelenk (31) und dem Gliedmassen-bezogenen Punkt (32) definierten Richtung als Wert einer ersten Funktion der Position des Gliedmassen-bezogenen Punktes (32),

25

Bereitstellen einer Darstellung der Position des Gliedmassen-bezogenen Punktes (32) im 3D-Raum (110) als einer Funktion des Abstands (35) auf der besagten Linie (30) zwischen dem Gelenk (31) und dem auf den Gliedmassen-bezogenen Punkt (32) auf einer der Anzeigeflächen (100-105) als eine zweite Funktion des besagten Wertes auf einer der Anzeigeflächen (100-105).

30

3. Verfahren nach Anspruch 1 oder 2, bei dem die eine oder mehreren Flächen (100-105) um den 3D-Raum (110) um den Benutzer (10) herum drei bis sechs Ebenen aus der Gruppe umfassen, die eine Frontalebene (105), eine linke Sagittalebene (101), eine rechte Sagittalebene (102), eine obere Querebene (103), eine untere Querebene (104) und eine hintere Ebene (100) umfasst, die insgesamt insbesondere einen Würfel aufspannen.

35

4. Verfahren nach irgendeinem der Ansprüche 1 bis 3, bei dem das Computerprogramm dafür angepasst ist, den Wert der ersten Funktion des Gliedmassen-bezogenen Punktes (32) auf der zugehörigen Oberfläche (100-105) durch einen Cursor (45, 46), insbesondere durch einen Pinsel (45) oder eine Sprühdüse, auf einem zugehörigen sichtbaren oder unsichtbaren Oberflächenabschnitt (40) zu visualisieren.

40

5. Verfahren nach Anspruch 4, bei dem das Computerprogramm dafür angepasst ist, dass es eine oder mehrere spezifische Größen des Oberflächenabschnitts (40) bestimmt und speichert, die einem spezifischen Wert der ersten Funktion des Gliedmassen-bezogenen Punktes (32) zugeordnet sind.

45

6. Verfahren nach irgendeinem der Ansprüche 1 bis 5, wobei die zweite Funktion der Darstellung des Gliedmassen-bezogenen Punktes (32) der Farbton oder die Opazität des zugeordneten Oberflächenteils (40) der Oberfläche (100-105) ist.

50

7. Verfahren nach Anspruch 6, wobei die Funktion der Darstellung monoton mit dem Wert der zweiten Funktion zu- oder abnimmt.

8. Verfahren nach Anspruch 6 oder 7, bei dem das Computerprogramm derart angepasst ist, dass es den Farbton oder die Opazität ändert, wenn der Wert der zweiten Funktion für den Gliedmassen-bezogenen Punkt (32) einen oder mehrere von vorbestimmten Schwellenwerten überschreitet.

55

9. Verfahren nach Anspruch 8, wobei der eine oder mehrere vorbestimmte Schwellenwerte vordefiniert und im Speicher des Computers für eine Vielzahl von spezifischen Richtungen (30) gespeichert sind.

10. Verfahren nach Anspruch 8 oder 9, wobei der Computer so angepasst ist, dass er in seinem Speicher den maximalen und/oder den minimalen Wert des Farbtons oder der Opazität eines der zugehörigen Oberflächenabschnitte (40) für die spezifische bestimmte Größe speichert, wenn der Benutzer mehr als einmal über die Oberflächenabschnitte (40) streicht.

EP 3 125 747 B1

- 5
10
15
20
25
30
35
40
45
50
11. System für eine Bewertung einer Bewegung eines Gliedmassen-bezogenen Punktes (32) in einem vorbestimmten 3D-Raum (110), die durch einen Benutzer bewirkt wird, der die Gliedmasse (15) in dem 3D-Raum (110) bewegt, das einen Computer (200) mit einem Prozessor, einem Speicher (201) und einem Computerprogramm umfasst, eine oder mehrere Anzeigeflächen (100-105), die um den 3D-Raum (110) um den Benutzer (10) herum angeordnet sind, einen Gliedmassen-Positionssensor (122), der dazu angepasst ist, Positionsdaten in dem 3D-Raum in Bezug auf eine vorbestimmte Ebene, die sich auf einen Gliedmassen-Positionspunkt (22) beziehen, zu empfangen (222), wobei der Gliedmassen-Positionspunkt (22) mit einem vorbestimmten Abschnitt der Gliedmasse (15) des Benutzers (10) verbunden ist, der dem Gliedmassen-bezogenen Punkt (32) zugeordnet ist, wobei das Computerprogramm so angepasst ist, dass es eine Position (x, y) des Gliedmassen-bezogenen Punktes in der besagten Ebene als Wert einer ersten Funktion der Position des Gliedmassen-bezogenen Punktes (32) zu berechnen und eine Darstellung (45) der Position des auf die Gliedmassen-bezogenen Punktes (32) im 3D-Raum (110) zu liefern, die sich auf den Abstand (z) zu dieser besagten Ebene als eine zweite Funktion des besagten Wertes auf einer der Anzeigeflächen (100-105) bezieht.
 12. System für eine Bewertung einer Bewegung eines Gliedmassen-bezogenen Punktes (32) in einem vorbestimmten 3D-Raum (110), die durch einen Benutzer bewirkt wird, der die Gliedmasse (15) in dem 3D-Raum (110) bewegt, das einen Computer (200) mit einem Prozessor, einem Speicher (201) und einem Computerprogramm umfasst, eine oder mehrere Anzeigeflächen (100-105), die um den 3D-Raum (110) um den Benutzer (10) herum angeordnet sind, einen Gliedmassen-Positionssensor (122), der dazu angepasst ist, Positionsdaten in Bezug auf einen Gliedmassen-Positionspunkt (22) zu empfangen (222), wobei der Gliedmassen-Positionspunkt (22) mit einem vorbestimmten Abschnitt der Gliedmasse (15) des Benutzers (10) verbunden ist, der dem Gliedmassen-bezogenen Punkt (32) zugeordnet ist, und der ferner einen Gelenksensor (121) aufweist, der dazu geeignet ist, Positionsdaten zu empfangen (221), die sich auf das Gelenk (31) beziehen, wobei das Computerprogramm so angepasst ist, dass es die Richtung, die durch die gerade Linie (30) zwischen dem Gelenk (11) und dem Gliedmassen-bezogenen Punkt (32) definiert ist, als Wert einer ersten Funktion der Position des Gliedmassen-bezogenen Punktes (32) berechnet und eine Darstellung (45) der Position des Gliedmassen-bezogenen Punktes (32) im 3D-Raum (110) als eine Funktion des Abstands (35) auf der besagten Linie (30) zwischen dem besagten Gelenk (31) und dem Gliedmassen-bezogenen Punkt auf einer der Anzeigeflächen (100-105) als eine zweite Funktion des Wertes auf einer der Anzeigeflächen (100-105) darstellt.
 13. Verfahren nach irgendeinem der Ansprüche 1 bis 11, bei dem die Bewertungsschritte von einem Prüfschritt gefolgt werden, der Folgendes umfasst:
 - Erzeugen eines ersten Datensatzes von Grenzen (132), die von einem System mit den Sensoren (21, 22) erreicht werden können,
 - Erzeugen eines zweiten Datensatzes von Grenzen (131), die für den Benutzer auf der Grundlage der Bewertungsschritte erreichbar sind,
 - Berechnung einer dritten Untermenge von Testgrenzen als Schnittpunkt des ersten Datensatzes mit dem zweiten Datensatz,
 - Definieren von Punkten (134) innerhalb der Testgrenzen als erreichbare Punkte und Definition von Punkten (133, 135) ausserhalb der Testgrenzen als nicht erreichbare Punkte,
 - Bereitstellen eines Zielpunktes (134) als Teil der Untermenge der erreichbaren Punkte als virtuelle Darstellung auf einer oder mehreren Anzeigeflächen (101-105) um den 3D-Raum (110) um den Benutzer (10) herum, der vom Benutzer (10) durch Bewegung eines Gliedmassenpositionspunktes (22) erreicht werden soll, der mit einem vorbestimmten Abschnitt der Gliedmasse (15) des Benutzers (10) verbunden ist, der dem Gliedmassen-bezogenen Punkt (32) zugeordnet ist, und
 - Auslösen eines Ergebnisereignisses, wenn der Benutzer (10) den besagten Zielpunkt (134) durch Bewegung der Gliedmasse erreicht.
 14. Verfahren nach Anspruch 13, bei dem die letzten beiden Schritte in einer Trainingssitzung mit zufällig oder gezielt wechselnden Zielpunkten (134), insbesondere in der Nähe der Grenzen der erreichbaren Punkte, wiederholt werden.

Revendications

- 55
1. Procédé d'évaluation d'un mouvement d'un point (32) relatif à un membre dans un espace 3D (110) prédéterminé, effectué par un utilisateur déplaçant ledit membre (15) dans l'espace 3D (110), comprenant les étapes suivantes:

EP 3 125 747 B1

fournir un ordinateur comprenant un processeur, une mémoire et un programme informatique,
fournir une ou plusieurs surfaces d'affichage (101-105) autour de l'espace 3D (110) autour de l'utilisateur (10),
fournir un point de position du membre (22) relié à une partie prédéterminée du membre (15) de l'utilisateur
(10) qui est associé au point (32) relatif au membre,
5 fournir un ou plusieurs capteurs adaptés pour détecter la position du point de position du membre (22) dans
l'espace 3D par rapport à un plan prédéterminé,
calculer, à l'aide du programme informatique adapté, une position (x,y) du point (32) relatif au membre dans
ledit plan comme une valeur d'une première fonction de la position du point (32) relatif au membre, et
10 fournir une représentation de la position du point (32) relatif au membre dans l'espace 3D (110) étant lié à la
distance (z) à ce plan comme une deuxième fonction de ladite valeur sur une des surfaces d'affichage (100-105).

2. Procédé d'évaluation d'un mouvement d'un point (32) relatif à un membre dans un espace 3D prédéterminé (110),
effectué par un utilisateur déplaçant ledit membre (15) dans l'espace 3D (110), dans lequel le mouvement du point
(32) relatif au membre est effectué autour d'une articulation (31) permettant ledit mouvement, comprenant les étapes
15 suivantes:

fournir un ordinateur comprenant un processeur, une mémoire et un programme informatique,
fournir une ou plusieurs surfaces d'affichage (101-105) autour de l'espace 3D (110) autour de l'utilisateur (10),
fournir un point de position du membre (22) relié à une partie prédéterminée du membre (15) de l'utilisateur
(10) qui est associé au point (32) relatif au membre,
20 fournir un ou plusieurs capteurs adaptés pour détecter la position du point de position du membre (22) dans
l'espace 3D par rapport à l'articulation (31),
calculer, à l'aide du programme informatique adapté, la direction définie par la ligne droite (30) entre l'articulation
(31) et le point (32) relatif au membre comme une valeur d'une première fonction de la position du point (32)
relatif au membre,
25 fournir une représentation de la position du point (32) relatif au membre dans l'espace 3D (110) étant une
fonction de la distance (35) sur ladite ligne (30) entre ladite articulation (31) et le point (32) relatif au membre
sur l'une des surfaces d'affichage (100-105) comme une deuxième fonction de ladite valeur sur l'une des
surfaces d'affichage (100-105).

3. Procédé selon la revendication 1 ou 2, dans lequel la ou les surfaces (100-105) autour de l'espace 3D (110) autour
de l'utilisateur (10) comprennent trois à six plans du groupe comprenant un plan frontal (105), un plan sagittal gauche
(101), un plan sagittal droit (102), un plan transversal supérieur (103), un plan transversal inférieur (104) et un plan
arrière (100), couvrant en particulier un cube.
35
4. Procédé selon l'une quelconque des revendications 1 à 3, dans lequel le programme informatique est adapté pour
visualiser la valeur de la première fonction du point (32) relatif au membre sur la surface correspondante (100-105)
par un curseur (45, 46), en particulier par un pinceau (45) ou une buse de pulvérisation, sur une partie de surface
visible ou invisible associée (40).
40
5. Procédé selon la revendication 4, dans lequel le programme informatique est adapté pour déterminer et stocker
une ou plusieurs tailles spécifiques de la partie de surface (40) associée à une valeur spécifique de la première
fonction du point (32) relatif au membre.
- 45
6. Procédé selon l'une quelconque des revendications 1 à 5, dans lequel la deuxième fonction de représentation du
point (32) relatif au membre est la teinte ou l'opacité de la partie de surface (40) associée à la surface (100-105).
7. Procédé selon la revendication 6, dans lequel la fonction de représentation augmente ou diminue de façon monotone
avec ladite valeur de la deuxième fonction.
50
8. Procédé selon la revendication 6 ou 7, dans lequel le programme informatique est adapté pour changer la teinte
ou l'opacité si la valeur de la deuxième fonction pour le point de position du membre (32) dépasse un ou plusieurs
des seuils prédéterminés.
- 55
9. Procédé selon la revendication 8, dans lequel le ou les seuils prédéterminés sont prédéfinis et stockés dans la
mémoire de l'ordinateur pour une pluralité de directions spécifiques (30).
10. Procédé selon la revendication 8 ou 9, dans lequel l'ordinateur est adapté pour stocker dans sa mémoire la valeur

EP 3 125 747 B1

maximale et/ou minimale, respectivement, de la teinte ou de l'opacité de l'une quelconque des parties de surface associées (40) pour la taille spécifique déterminée, si l'utilisateur balaye plus d'une fois les parties de surface (40).

- 5
11. Système pour une évaluation d'un mouvement d'un point (32) relatif à un membre dans un espace 3D prédéterminé (110), effectué par un utilisateur déplaçant ledit membre (15) dans l'espace 3D (110), comprenant un ordinateur (200) ayant un processeur, une mémoire (201) et un programme informatique, une ou plusieurs surfaces d'affichage (100-105) disposées autour de l'espace 3D (110) autour de l'utilisateur (10), un capteur de position de membre (122) adapté pour recevoir (222) des données de position dans l'espace 3D par rapport à un plan prédéterminé relatives à un point de position de membre (22), dans lequel le point de position de membre (22) est relié à une partie prédéterminée du membre (15) de l'utilisateur (10) qui est associé au point (32) relatif au membre, dans lequel le programme informatique est adapté pour calculer une position (x, y) du point relatif au membre dans ledit plan étant une valeur d'une première fonction de la position du point (32) relatif au membre et pour fournir une représentation (45) de la position du point (32) relatif au membre dans l'espace 3D (110) qui est liée à la distance (z) audit plan comme deuxième fonction de ladite valeur sur l'une des surfaces d'affichage (100-105).
- 10
- 15
12. Système pour une évaluation d'un mouvement d'un point (32) relatif à un membre dans un espace 3D prédéterminé (110), effectué par un utilisateur déplaçant ledit membre (15) dans l'espace 3D (110), comprenant un ordinateur (200) ayant un processeur, une mémoire (201) et un programme informatique, une ou plusieurs surfaces d'affichage (100-105) disposées autour de l'espace 3D (110) autour de l'utilisateur (10), un capteur de position de membre (122) adapté pour recevoir (222) des données de position relatives à un point de position de membre (22), dans lequel le point de position de membre est relié à une partie prédéterminée du membre (15) de l'utilisateur (10) qui est associé au point (32) relatif au membre, comprenant en outre un capteur d'articulation (121) adapté pour recevoir (221) des données de position relatives à l'articulation (31), dans lequel le programme informatique est adapté pour calculer la direction définie par la ligne droite (30) entre l'articulation (11) et le point (32) relatif au membre comme valeur d'une première fonction de la position du point (32) relatif au membre et pour fournir une représentation (45) de la position du membre-(32) dans l'espace 3D (110) étant une fonction de la distance (35) sur ladite ligne (30) entre ladite articulation (31) et le point relatif au membre sur l'une des surfaces d'affichage (100-105) comme une deuxième fonction de ladite valeur sur l'une des surfaces d'affichage (100-105).
- 20
- 25
- 30
13. Procédé selon l'une quelconque des revendications 1 à 11, dans lequel les étapes d'évaluation sont suivies d'une étape de test, comprenant
générer un premier ensemble de données de limites (132) accessibles par un système comprenant les capteurs (21, 22),
générer un deuxième ensemble de données de limites (131) accessibles à l'utilisateur sur la base des étapes d'évaluation,
calculer un troisième sous-ensemble de limites de test comme intersection du premier ensemble de données avec le deuxième ensemble de données,
définir des points (134) à l'intérieur desdites limites de test comme des points atteignables et définir des points (133, 135) à l'extérieur desdites limites de test comme des points non atteignables,
fournir un point cible (134) faisant partie du sous-ensemble de points atteignables en tant que représentation virtuelle sur une ou plusieurs surfaces d'affichage (101-105) autour de l'espace 3D (110) autour de l'utilisateur (10) à atteindre par l'utilisateur (10) par le déplacement d'un point de position de membre (22) relié à une partie prédéterminée du membre (15) de l'utilisateur (10) qui est associé au point (32) relatif au membre, et
déclencher un événement de résultat, lorsque l'utilisateur (10) atteint ledit point cible (134) par un mouvement du membre.
- 35
- 40
- 45
14. Procédé selon la revendication 13, dans lequel les deux dernières étapes sont répétées dans une session d'entraînement avec des points cibles (134) changeant de manière aléatoire ou spécifique, en particulier près des limites des points atteignables.
- 50
- 55

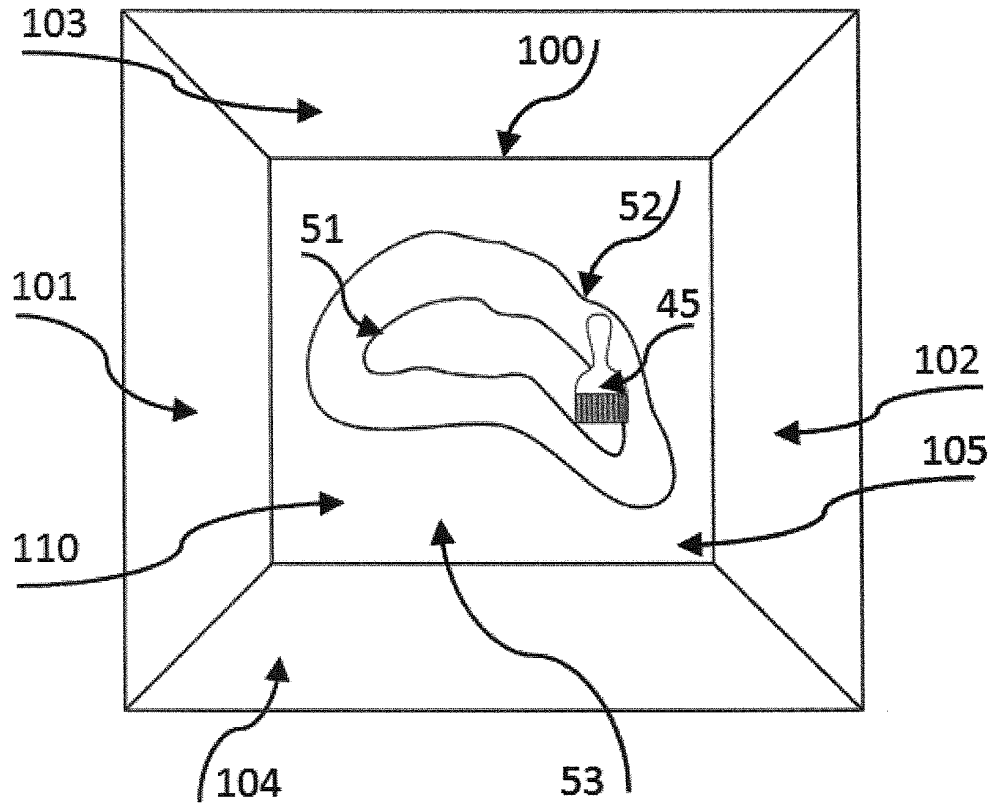

FIG. 1

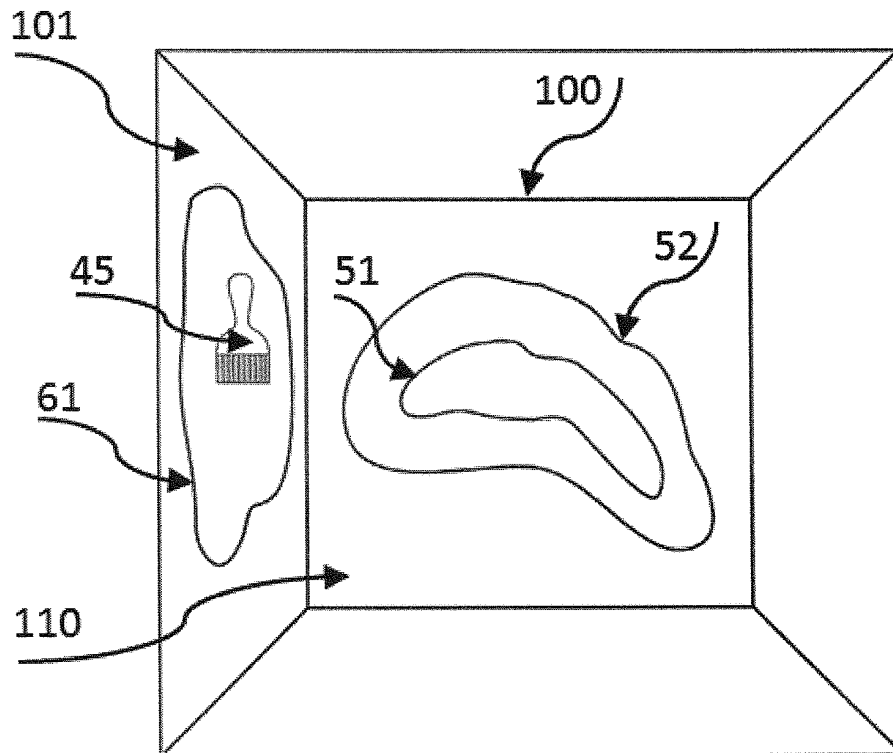
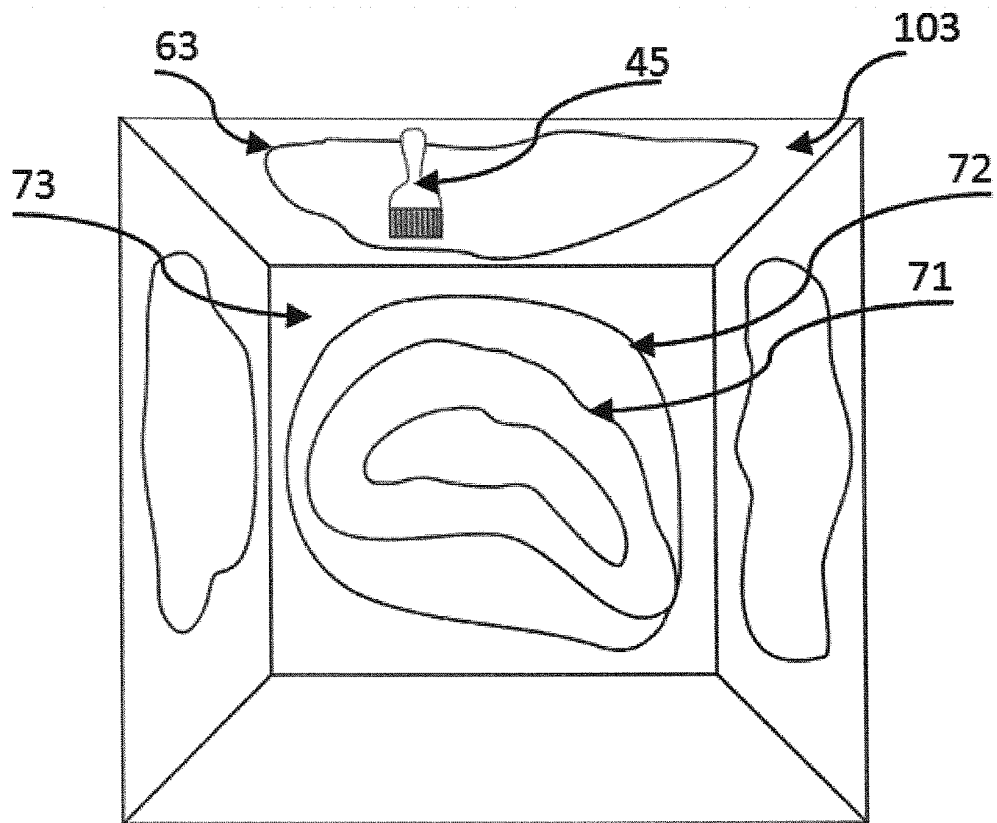
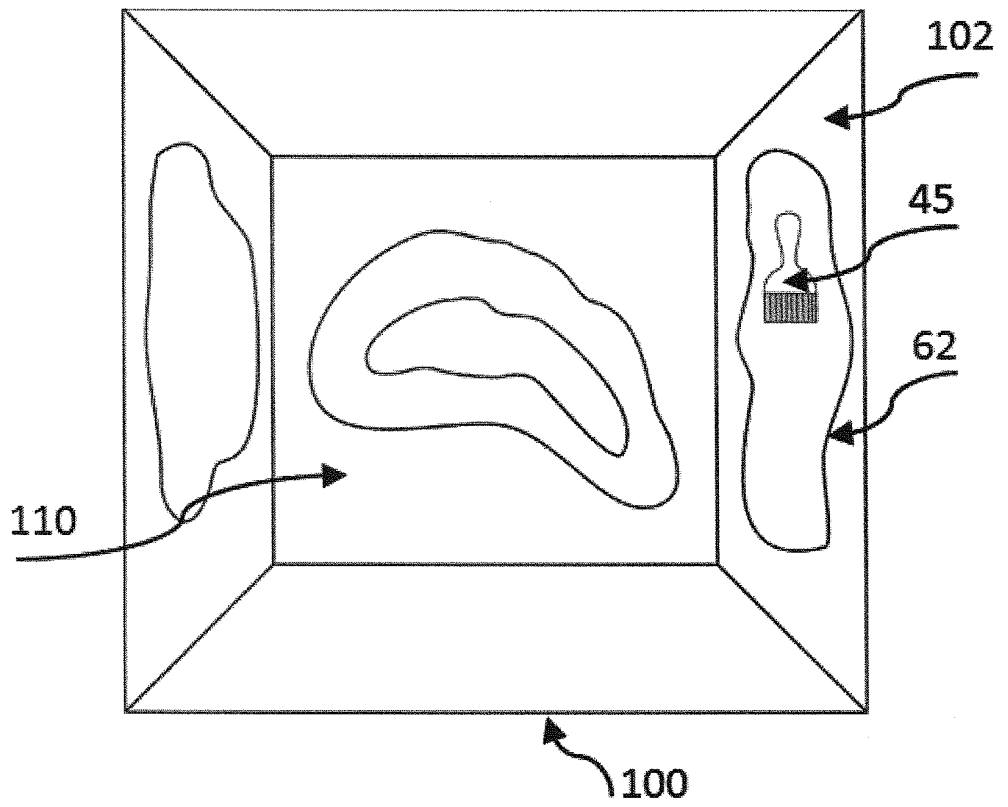

FIG. 2



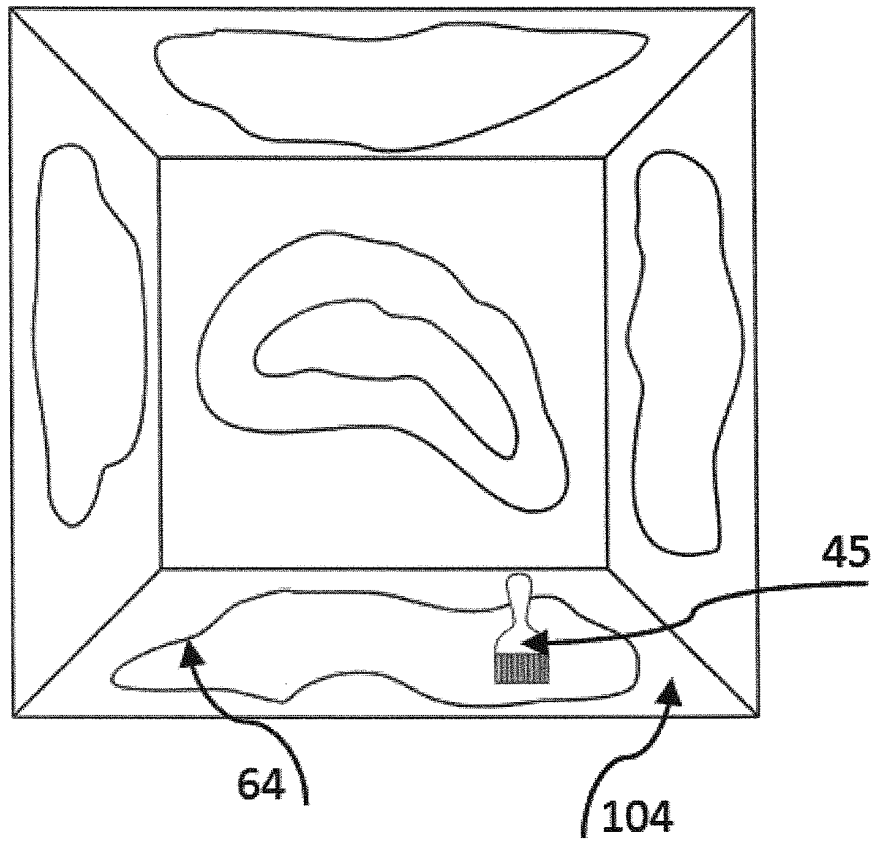

FIG. 5

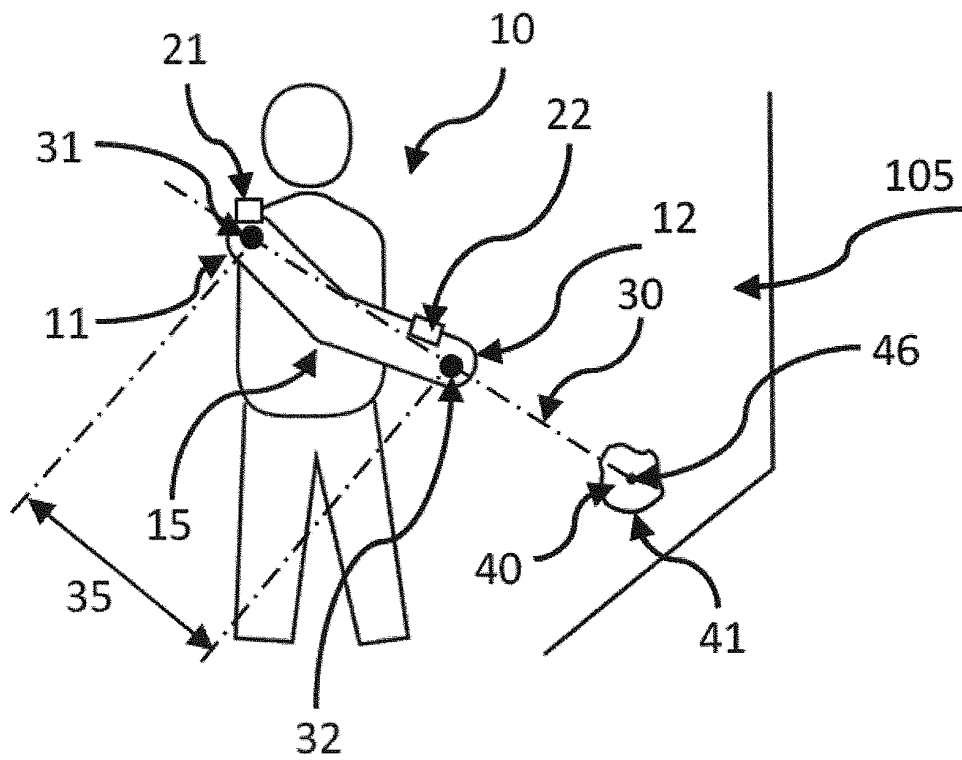

FIG. 6

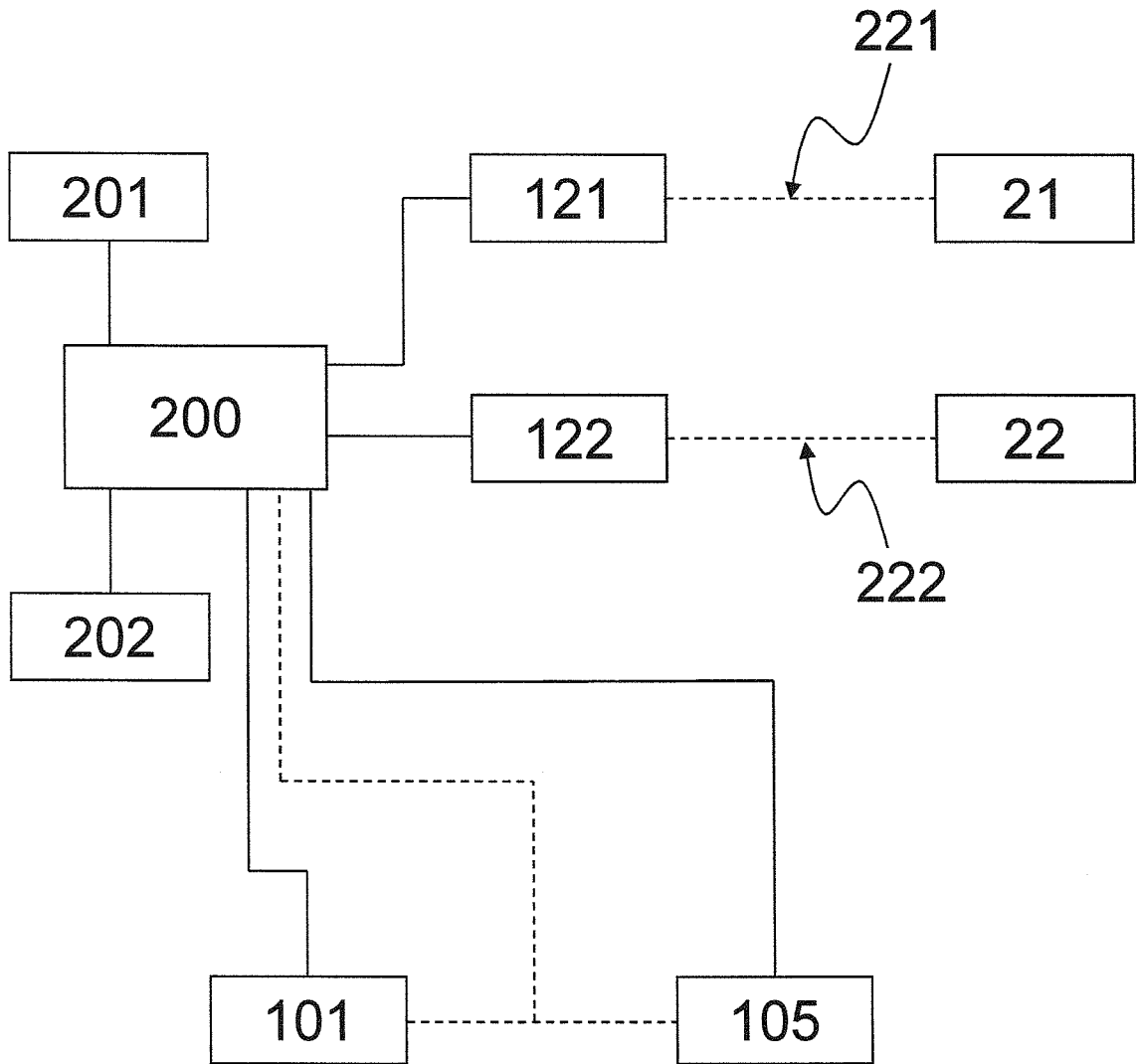

FIG. 7

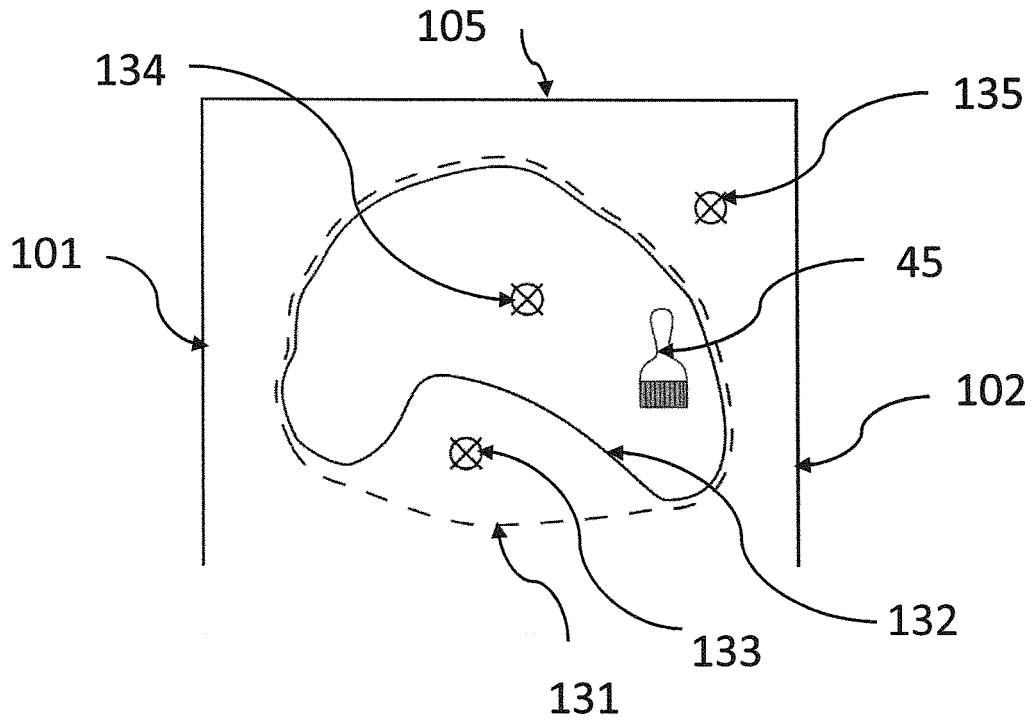

FIG. 8

REFERENCES CITED IN THE DESCRIPTION

This list of references cited by the applicant is for the reader's convenience only. It does not form part of the European patent document. Even though great care has been taken in compiling the references, errors or omissions cannot be excluded and the EPO disclaims all liability in this regard.

Patent documents cited in the description

- EP 2660742 A [0008]
- US 2013171601 A [0008]
- WO 2011004403 A [0008]

Non-patent literature cited in the description

- **GREGORIJ KURILLO ; JAY J. HAN ; RICHARD T. ABRESCH ; ALINA NICORICI ; POSU YAN ; RUZENA BAJCSY.** Development and Application of Stereo Camera-Based Upper Extremity Workspace Evaluation in Patients with Neuromuscular Diseases. *PLOSONE*, 17 September 2012, vol. 7 (9), e45341 [0002]
- **CLAUDIA RUDHE ; URS ALBISSER ; MICHELLE L STARKEY ; ARMIN CURT ; MARC BOLLIGER.** Reliability of movement workspace measurements in a passive arm orthosis used in spinal cord injury rehabilitation. *Journal of NeuroEngineering and Rehabilitation*, 2012, vol. 9, 37, <http://www.jneuroengrehab.com> [0004]
- **KLOPCAR N ; TOMSIC M ; LENARCIC J.** A kinematic model of the shoulder complex to evaluate the arm-reachable workspace. *J Biomech*, 2005, vol. 40, 86-91 [0007]
- **J.C.CARR et al.** *Reconstruction and Representation of 3D Objects with Radial Basis Functions*, <http://www.cs.jhu.edu/~misha/Fall05/Papers/carr01.pdf> [0022]

专利名称(译)	评估预计3D空间中肢相关点运动的方法和系统		
公开(公告)号	EP3125747B1	公开(公告)日	2020-04-22
申请号	EP2015712945	申请日	2015-03-31
[标]申请(专利权)人(译)	浩康股份公司		
申请(专利权)人(译)	HOCOMA AG		
当前申请(专利权)人(译)	HOCOMA AG		
[标]发明人	HOVER RAPHAEL FISCH PETER		
发明人	HÖVER, RAPHAEL FISCH, PETER		
IPC分类号	A61B5/00 A61B5/11		
CPC分类号	A61B5/1122 A61B5/1124 A61B5/1127 G06F3/011 A61B5/1126 A61B5/742		
优先权	2014162652 2014-03-31 EP		
其他公开文献	EP3125747A1		
外部链接	Espacenet		

摘要(译)

一种用于评估在预定的3D空间中肢体相关点(32)的运动的方法,该方法由用户将所述肢体(15)放置在允许该运动的3D空间中来实现,该方法包括以下步骤:提供计算机,提供围绕用户(10)的3D空间的一个或多个显示表面(105),提供连接到与用户(10)的肢体(15)的预定部分相关的肢体位置点(22)相关点(32),并提供传感器以检测肢体位置点(22)在3D空间中相对于关节(31)的位置。该计算机程序可以适于计算由关节(31)和肢体相关点(32)之间的直线(30)定义的方向,并提供肢体相关点(32)的位置的表示。在3D空间中的角度,取决于所述关节(31)和所述线(30)上显示表面(105)之一上肢体相关点(32)之间的距离(35)。

