

(19)



(11)

**EP 3 494 866 B1**

(12)

**EUROPEAN PATENT SPECIFICATION**

(45) Date of publication and mention of the grant of the patent:  
**26.02.2020 Bulletin 2020/09**

(51) Int Cl.:  
**A61B 3/00** (2006.01)      **A61B 3/113** (2006.01)  
**G02C 7/02** (2006.01)      **A61B 5/00** (2006.01)  
**G02C 13/00** (2006.01)      **A61B 3/11** (2006.01)

(21) Application number: **17306716.6**

(22) Date of filing: **06.12.2017**

**(54) METHOD AND APPARATUS FOR DETERMINING A REFERENCE HEAD POSTURE OF A SUBJECT**

VERFAHREN UND VORRICHTUNG ZUR BESTIMMUNG EINER REFERENZKOPFHALTUNG EINER PERSON

PROCÉDÉ ET APPAREIL POUR DÉTERMINER LA POSTURE DE TÊTE DE RÉFÉRENCE D'UN SUJET

(84) Designated Contracting States:  
**AL AT BE BG CH CY CZ DE DK EE ES FI FR GB GR HR HU IE IS IT LI LT LU LV MC MK MT NL NO PL PT RO RS SE SI SK SM TR**

(43) Date of publication of application:  
**12.06.2019 Bulletin 2019/24**

(73) Proprietor: **Essilor International**  
**94220 Charenton-le-Pont (FR)**

(72) Inventor: **LE SAUX, Gilles**  
**94220 CHARENTON-LE-PONT (FR)**

(74) Representative: **Jacobacci Coralie Harle**  
**32, rue de l'Arcade**  
**75008 Paris (FR)**

(56) References cited:  
**WO-A1-2010/145736 DE-A1-102014 013 447**  
**US-A1- 2010 128 220**

**EP 3 494 866 B1**

Note: Within nine months of the publication of the mention of the grant of the European patent in the European Patent Bulletin, any person may give notice to the European Patent Office of opposition to that patent, in accordance with the Implementing Regulations. Notice of opposition shall not be deemed to have been filed until the opposition fee has been paid. (Art. 99(1) European Patent Convention).

**Description**

## TECHNICAL FIELD OF THE INVENTION

**[0001]** The invention pertains to the domain of optometry and to the measurements of parameters relative to a subject wearing an ophthalmic lens.

**[0002]** More precisely, the invention relates to a method and apparatus for determining a reference head posture of a subject.

**[0003]** The invention also proposes a method for measuring a distinctive height associated with a frame of a pair of spectacles worn by the subject.

**[0004]** Further, the invention relates to a method for mounting and for verifying the mounting of an ophthalmic lens in a frame of a pair of spectacles.

## BACKGROUND INFORMATION AND PRIOR ART

**[0005]** Numerous documents describe devices and methods for determining the head posture of a subject.

**[0006]** For example, document WO 2010/145736 provides an improved method for determining the head posture of a subject. The method of WO 2010/145736 comprises: recording the head posture of the subject over a certain period of time; and, determining a preferred, or "habitual", head posture from the recorded head posture.

**[0007]** This method prevent the habitual head posture of the subject from being mistakenly assumed as a head posture which is recorded or determined randomly at a point in time and which precisely does not correspond to the subject's usual head posture.

**[0008]** However, this method may be a tedious work for the eye-care practioner who shall equip the subject with a device on his/her head or on his/her frame, and make a long video recording. Moreover, although the result of the measurement may be very precise, it is very variable from one day to the next.

## SUMMARY OF THE INVENTION

**[0009]** Therefore one object of the invention is to provide a precise, reliable and simple method for determining a reference head posture of a subject which is precise and simple to implement by an eye-care practioner, but which is also reliable and reproducible from one day to the next.

**[0010]** The above object is achieved according to the invention by providing a method comprising the steps of:

a) asking the subject to:

- a1) adopt an initial head posture wherein he/she directs his/her gaze towards a predetermined direction;
- a2) move his/her head up and down starting from said initial head posture while keeping his/her gaze directed towards said predeter-

mined direction; and

b) determining said reference head posture as a function of a movement or a position of at least one eyelid of the subject during the motion of his/her head at step a2).

**[0011]** Indeed, it has been found by the Applicant that the head posture of the subject determined according to this method is very reliable and does not depend on the time the measurement is performed.

**[0012]** In particular, the method according to the invention allows determining a reference head posture which is very specific for each subject.

**[0013]** Other advantageous and non limiting features of the method according to the invention are as follows:

- at step b), the at least one eyelid of the subject is his/her upper eyelid;
- the reference head posture is determined at step b) as the posture adopted by the subject at an instant where said at least one upper eyelid stops, respectively starts, moving when the head of the subject is moving down, respectively is moving up;
- the reference head posture is determined at step b) as the posture adopted by the subject at an instant where said at least one upper eyelid fits in, respectively get out of, an arch of the corresponding eyebrow of the subject, when the head of the subject is moving up, respectively is moving down.
- at step a1), the predetermined direction is the subject's gaze direction when he/she is looking at a fixed point straight ahead or at himself/herself in a mirror or on a display screen;
- at step b), said reference head posture is determined while observing visually or by means of a video camera the movement and/or the position of said at least one eyelid of the subject.

**[0014]** A further object of the invention is to provide a measurement method which benefits from the determination of the reference head posture to allow making the measurement always in the same head posture of the subject.

**[0015]** Hence, the invention proposes a method for measuring a distinctive height associated with a frame of a pair of spectacles worn, physically or virtually, by said subject, said method comprising the steps of:

- determining a reference head posture of the subject using a method of determination in accordance with the above-detailed invention; and
- when the head of the subject is in said reference head posture, determining a measured value of said distinctive height as a function of the distance, along a vertical direction substantially perpendicular to the initial predetermined direction, between a center of one pupil of the subject and a bottom edge of said

frame.

**[0016]** Advantageously, one acquires, at step b), a tilt angle of the head of the subject with respect to said vertical direction; and one determines said distinctive height when the head of the subject is tilted with respect to said vertical direction by the acquired tilt angle.

**[0017]** Other advantageous and non limiting features of the measurement method according to the invention are as follows:

- one determines a real value of said distinctive height with an offset to the measured value;
- said offset depends on subject's ethnicity;
- when the subject wears virtually said pair of spectacles, one positions said frame with respect to the head of the subject in accordance with a distance along said vertical direction between the eyebrows of the subject and a top edge of said frame; and
- one determines said measured value of the distinctive height in lighting conditions adapted to reduce the size of the pupil of the subject.

**[0018]** Another object of the invention is to provide a way to help and verify the mounting of a lens in a frame.

**[0019]** More precisely, the invention pertains to a method for verifying the mounting of at least one ophthalmic lens in a frame of a pair of spectacles designed to be worn by a subject, said method comprising the steps of:

- determining a reference head posture of the subject using a method of determination according to the invention;
- capturing a first image of the frame when the subject is in said reference head posture and wears said frame without the at least one ophthalmic lens;
- mounting in said frame the at least one ophthalmic lens having a marking;
- capturing a second image of the frame fitted with the at least one ophthalmic lens displaying said marking;
- processing said first and second images so as to superimpose the images of the frame in both images;
- determining a calculated value of the distance between said marking and a center of a pupil of an eye of the subject to be visually corrected with said ophthalmic lens;
- comparing said calculated value with a threshold value; and
- verifying the mounting of the at least one ophthalmic lens in the frame as a function of the previous comparison.

**[0020]** Finally, the invention relates to an apparatus for determining a reference head posture of a subject comprising:

- image-capturing means adapted to capture a movement or a position of at least one eyelid of the subject

while he/she moves his/her head up and down starting from an initial head posture wherein he/she directs his/her gaze towards a predetermined direction, the subject keeping his/her gaze directed towards said predetermined direction during the motion of his/her head; and

- image-processing means configured to analyze images or films captured by said image-capturing means and to determine said reference head posture as a function of a movement or a position of at least one eyelid of the subject.

**[0021]** In a preferred embodiment, the apparatus according to the invention comprises eye-catching means arranged in front of the subject so that he/she adopts an initial head posture wherein he/she directs his/her gaze towards a predetermined direction.

**[0022]** In another embodiment, the eye-catching means are provided in addition to the apparatus of the invention.

**[0023]** Advantageously, the eye-catching means may comprise a light source positioned at a same height as the eyes of the subject.

**[0024]** Alternatively, the eye-catching means may comprise a mirror or a display screen positioned in front of the subject so that the predetermined direction is substantially horizontal.

**[0025]** In another preferred embodiment where said subject wearing physically or virtually a pair of spectacles, the apparatus according to the invention is such that:

- the image-capturing means are adapted to capture at least one image of the subject when his/her head is in said reference head posture; and
- the image-processing means are further configured to analyze said at least one image and to determine a measured value of a distinctive height associated with a frame of said pair of spectacles as a function of the distance, along a vertical direction substantially perpendicular to the initial predetermined direction, between a center of one pupil of the subject and a bottom edge of said frame.

**[0026]** Advantageously, said image-capturing means have an optical axis parallel to a visual axis of the subject. This prevents the measurement to be distorted by a parallax error.

#### DETAILED DESCRIPTION OF EXAMPLES

**[0027]** The following description made with reference to the accompanying drawings given by way of non-limiting example makes it clearly understood what the invention consists in and how it can be reduced to practice.

**[0028]** In the accompanying drawings:

- figure 1 is a schematic representation of a subject in

front of an apparatus according to a first embodiment of the invention;

- figure 2 is a top view of figure 1 showing both eyes of the subject;
- figures 3 and 4 are schematic drawings of the head of the subject in the initial head posture and in the reference head posture respectively;
- figure 5 is a schematic drawing of the eye of a subject showing his eyelids and the pupil of his eye in an initial head posture;
- figure 6 is a schematic drawing of the eye of figure 5 in the reference head posture;
- figure 7 is a schematic representation of an eye of a subject wearing frame of a pair of spectacles, with a detail on the fitting height between the bottom of the frame and the center of the pupil.

**[0029]** We will describe hereafter a method and apparatus for determining a reference head posture of a subject 1 (see figure 1) where one uses the position and/or the movement of one or both eyelids of the subject, while he (we will assume for the rest of the description that the subject is a man) moves his head.

**[0030]** This reference head posture, which is specific for each subject, is quite stable and does not vary very much from one day to the other.

**[0031]** Hence, determining the reference head posture of the subject 1 is particularly useful when carrying out optical and/or eye- or head-related measurements of the subject 1, in view of the design and manufacturing of eyeglasses, in particular for progressive addition lenses (PAL).

**[0032]** We represented on figure 1 an apparatus 10 according to a particular embodiment of the invention. The apparatus 10 comprises a digital video recorder 11 (hereinafter referred to as a camera) and a computer system 12, linked to the camera 10 by a digital cable 19 for 2-ways communication.

**[0033]** In this particular embodiment, the apparatus 10 further comprises eye-catching means 13, 14 arranged in front of the subject 1 so that he adopts an initial head posture wherein he directs his gaze 16, 17 towards a predetermined direction 18 (see fig. 1A).

**[0034]** The eye-catching means 13, 14 comprise here a light source 13, e.g. a light-emitting diode (LED), and a semi-transparent or dichroic mirror 14 positioned and oriented in front of the subject 1 with respect to the light source 13 and the head 2 of the subject 1 so that the predetermined direction 18 is substantially horizontal, along the horizontal axis Y (see arrows in figs. 1 and 1A).

**[0035]** In other words, the LED 13 is placed just above/upright the mirror 14 which is tilted with a 45° angle relative to the vertical axis X so that the (virtual) image of the light source 13 is positioned on the horizontal axis Y (behind the mirror 14, near the camera 11), along the predetermined direction 18.

**[0036]** In a variant, the light source may be positioned at the same height as the eyes of the subject, so that the

initial head posture is the one that the subject would adopt when looking at a far-distant point (far vision).

**[0037]** In another variants, the predetermined direction may be defined by the subject's gaze direction when he is looking at a fixed point straight ahead (a light source placed close to the camera 11) or at himself in a mirror or on a display screen, e.g. on the screen of his cell phone of his digital tablet.

**[0038]** The camera 11 is preferably positioned in front of the head 2 of the subject 1, behind the semi-transparent or dichroic mirror 14, and has an optical axis 15 which is preferably parallel to the visual axis 18 (see fig. 1A) of the subject 1 (to avoid parallax issue when capturing the images of both eyes of the subject).

**[0039]** The camera 11 is optically and mechanically set up to capture images of the head 2 and the eyes 3, 4 of the subject 1 placed in front of the camera 11.

**[0040]** The computer system 12 may also includes a video screen 12 to monitor in real time the images or films recorded by the camera 11. The computer system 12 comprises calculation means suitable to analyze the images captured by the camera 11 and run image-processing algorithms to extract useful information from those images and determine the looked-for reference head posture as a function of a movement or a position of at least one eyelid of the subject.

**[0041]** Using the apparatus 10 of figure 1, it is possible to perform a method according to the invention, said method comprising the steps of:

a) asking the subject 1 to:

a1) adopt an initial head posture wherein he directs his gaze towards the predetermined direction 18;

a2) move his head up and down (see double arrow 20 on figure 1) starting from the initial head posture while keeping his gaze directed towards the predetermined direction 18; and

b) determining the reference head posture as a function of a movement or a position of at least one eyelid of the subject 1 during the motion of his head at

step a2).

**[0042]** We have represented on figures 3 and 4, the head 2 of the subject 1 when he is respectively in the initial head posture (case of figure 3) and in the reference head posture (case of figure 4).

Step a)

**[0043]** At the beginning of the method, the subject 1 sits, or stands, in front of the apparatus 10 and tries to focus on the image of the light source 13 reflected by the mirror 14. In this situation, his gaze (i.e. the lines of sight 16, 17 in figure 2) is directed towards the image, defining

the predetermined direction 18.

**[0044]** In this initial head posture (figure 3), we represented on figure 5 a detailed view of the (right) eye 3 of the subject 1 with:

- the lower eyelid 5 and the upper eyelid 9;
- the sclera 6;
- the iris 7 and the pupil 8.

**[0045]** In a preferred embodiment of the invention, the lighting conditions of the experiment is such that the subject 1 is in photopic conditions (high environment luminance level above roughly 300 cd/m<sup>2</sup>) so that the pupil 8 of the eye 3 of the subject 1 is close to its minimum size (myosis), which is generally around 1.5 to 2 millimeters.

**[0046]** In practice here, the photopic conditions are obtained with ambient lighting (e.g. such as those usually found at an optical shop) and with the light level of the light source 13.

**[0047]** As shown on figure 5, the upper eyelid 9 of the right eye 3 is at this time lifted up, such that it only hides a small upper part of the iris 7, yet without vignetting the pupil 8.

**[0048]** In the initial head posture (figures 3 and 5), one may acquire an image of the entire eye 3 of the subject 1, including the eyebrow 20 of the subject and the arch 21 of the eyebrow 20. Preferably, one can process the acquired image to identify the arch 21 and the edge 22 of the upper eyelid 9, and calculate an initial position of the upper eyelid 9 of the eye 3, defined by the distance, along the vertical axis 23 (parallel to axis X), from the arch 21 to the edge 22 of the upper eyelid 9.

**[0049]** Then, starting from the initial head posture (figure 3) where the subject 1 directs his gaze 16 in the predetermined direction 18, the subject 1 is asked to move his head 2 up and down (step a2; see double arrow 20 on figure 3) without stopping looking towards the image of the light source 13 and preferably without turning his head 2 to the left or to the right.

#### Step b)

**[0050]** During the whole motion of his head 2, the camera 11 of the apparatus 10 records, e.g. at a sampling rate of 30 or 60 Hz, the images of the eyes 3, 4 of the subject 1 and send the images to the computer system 12 for image processing and analysis.

**[0051]** The reference head posture (see figure 4) is then determined as a function of the movement or the position of the upper eyelid 9 of the subject 1 during the motion of his head 2.

**[0052]** In an alternative embodiment, the lower eyelid 5 may be used in the images of the eye of the subject.

**[0053]** As shown in figure 6, in the reference head posture, the upper eyelid 9 is here lowered with respect to its initial position (initial head posture of figure 3) such that it hides almost one half of the iris 7 (see above).

**[0054]** In the reference head posture (figure 4), one may also calculate a "reference" position of the upper eyelid 9 of the eye 3, defined again by the distance, along the vertical axis 23 (parallel to axis X), from the arch 21 to the edge 22 of the upper eyelid 9 (see figure 6).

**[0055]** In particular embodiments of the method according to the invention, the reference head posture is determined at step b) as the posture adopted by the subject 1 at an instant where the upper eyelid 9 fits in, or respectively gets out of, the arch 21 of the corresponding eyebrow 20 of the subject 1, when the head 2 of the subject 1 is moving down, respectively is moving up.

**[0056]** When the reference head posture is located thanks to the movement of the upper eyelid 9, it is determined at step b) as the head posture adopted by the subject 1 at an instant where the upper eyelid 9 stops, respectively starts, moving when the head 2 of the subject 1 is moving up, respectively is moving down.

**[0057]** The reference head posture may be determined either with the video camera 11 (cases of figures 4 and 6) or directly by a visual observation. In case of visual observation, one may equip the subject with a special device recording the inclination angle of the head of the subject. The eye-care practitioner (ECP) who carries the method then notes the inclination angle corresponding to the reference head posture of the subject.

**[0058]** Then, in order to reproduce the reference head posture, determined previously with the method, it is possible to fit the head 2 of the subject 1 (if he doesn't wear a frame) or the frame he wears with the above inclination device; and ask the subject 1 to tilt his head 2 until the inclination angle equalize the value determined during the previous measurement.

**[0059]** The above-detailed apparatus 10 and method may be used/implemented when the subject is wearing, or not, eyeglasses with a frame, with or without an ophthalmic lens fitted in the frame. Those eyeglasses may be the one he usually wears or a new one he chose.

**[0060]** The above apparatus and method are particularly interesting in order to take various measurements on the subject 1 when he is in the reference head posture, as the reference head posture is kind of specific of the subject 1 in determined conditions.

**[0061]** It is specifically interesting when it comes to measure geometric and/or morphological distances or lengths on the eye 2 of the subject 1 wearing a frame of a pair of spectacles. More precisely, with reference to figure 7, the invention proposes also a method for measuring a distinctive height, hereinafter referred to as fitting height B, associated with a frame 24 of a pair of spectacles worn, physically or virtually, by the subject 1.

**[0062]** Said measuring method comprises the steps of:

- determining the reference head posture of the subject 1 using a method of determination according to the invention (see above); and
- when the head 2 of the subject 1 is in this reference head posture, determining a measured value B of

the fitting height as a function of the distance, along a vertical direction X substantially perpendicular to the initial predetermined direction 18 (see fig. 2), between a center 28 of a pupil 8 of the subject 1 and a bottom edge 27 of said frame 24.

**[0063]** In order to determine the measured value of the fitting height B, one can use the same apparatus 10 as in figure 10. In this case, the computer system 12 is then configured to process the images of the head 2 and of the eyes 3, 4 of the subject 1 captured by the camera 11 in order to detect both the the pupil 8 of the eye 3 and the circle 25 of the frame 24 (when said frame comprises two circles 25 linked by a bridge 26, see fig. 10).

**[0064]** Once the pupil 8 and the circle 25 are detected, the center 28 of the pupil 8 and the inner edge 26 of circle 25 can be determined, and the distance, i.e. the distinctive height, along the vertical axis X between the center 28 and the edge 26.

**[0065]** Advantageously, one acquires, at step b) of the method of determination, a tilt angle of the head 2 of the subject 1 with respect to the vertical direction 23; and one determines the fitting height when the head 2 of the subject 1 is tilted with respect to the vertical direction X by the acquired tilt angle  $\theta_1$ .

**[0066]** In a preferred embodiment of the invention, one determines a real value  $B_R$  of said fitting height with an offset  $\delta B$  to the measured value B, the offset depending for example on subject's ethnicity: Caucasian, Eurasian, Asian, etc....

**[0067]** The value  $\delta B$  of the offset may be, for example, the average angular difference of the inclination angle (measured by an inclination device) measured between the reference head posture and a natural head posture of the subject.

**[0068]** In another preferred embodiment, one determines the measured value B of the fitting height in lighting conditions adapted to reduce the size of the pupil 8 of the subject 1. In those lighting conditions, the smaller size of the pupil 8 (due to the myosis of the iris 7) allows reaching a better precision in the determination of the center 28 of the pupil 8.

**[0069]** When the subject 1 wears virtually the pair of spectacles (i.e. a virtual frame is digitally added by the computer system 12 to the images of the head 2 of the subject 1 recorded by the camera 11), one positions the frame 24 with respect to the head 2 of the subject 1 in accordance with a distance H (see fig. 7) along a vertical direction 23 (X axis) between the eyebrows 20 of the subject 1 and a top edge 29 of said frame 25.

**[0070]** The above apparatus 10 and method for determining the reference head posture of the subject 1 may be also used/implemented for a method for verifying the mounting of at least one ophthalmic lens in a frame of a pair of spectacles designed to be worn by the subject.

**[0071]** This advantageous method comprises the steps of:

- determining the reference head posture of the subject 1 using a method of determination according to the invention (see above);
- capturing a first image of the frame when the subject is in the reference head posture and wears the frame without the at least one ophthalmic lens;
- mounting in the frame the at least one ophthalmic lens having a marking;
- capturing a second image of the frame fitted with the at least one ophthalmic lens displaying said marking;
- processing said first and second images so as to superimpose the images of the frame in both images;
- determining a calculated value of the distance between said marking and a center of a pupil of an eye of the subject to be visually corrected with the ophthalmic lens.
- comparing said calculated value with a threshold value; and
- verifying the mounting of the at least one ophthalmic lens in the frame as a function of the previous comparison.

**[0072]** The basic principles of this measurement are as follows.

**[0073]** First, after the subject has chosen the eyeglasses frame he wants and after having adjusted this frame (without the ophthalmic lenses) on his head, one may ask the subject 1 to adopt an initial head posture (see step a1 above) where he directs his gaze towards a predetermined direction. In this first configuration, one acquires a first image of the face of the subject. This first image is processed, for example to determine the measured values of the inter-pupillary distance and of the fitting height between the center of pupils and the bottom edges of the frame (see details above). The first image and the value of the fitting height are provided to an operator which is responsible for the mounting of the ophthalmic lens(es) in the frame.

**[0074]** Then, this operator fits the one or two prescribed ophthalmic lenses in the selected frame. Like it is well known in the field, this fitting is done on the basis of the optical and geometric parameters of the lenses and of the geometric and morphological values previously measured (inter-pupillary distance, distinctive height, etc...). In this second configuration, one acquires the second image of the frame fitted with the ophthalmic lenses, taking care that the usual fitting marks (marking) present on the lenses for mounting are visible on this second image.

**[0075]** Then, by digital processing, one tries superimposing, in a third image, the first and second images by modifying the size and/or shape of the image of the frame in the first image.

**[0076]** In this third image, still by numerical analysis of images, one calculates (or visually evaluates on a screen where the third image is displayed) the value of the distance between the marking and the left/right center of the pupil of the eye of the subject.

**[0077]** If the mounting is correct, then the calculated value should be smaller than a predetermined threshold value. On the contrary, if the calculated value is larger than the threshold value then the mounting of the ophthalmic lenses in the frame are not verified, and e.g. a corrective mounting operation can be performed by the operator.

## Claims

1. Method for determining a reference head posture of a subject, said method comprising the steps of:

a) asking the subject to:

a1) adopt an initial head posture wherein he/she directs his/her gaze towards a predetermined direction;

a2) move his/her head up and down starting from said initial head posture while keeping his/her gaze directed towards said predetermined direction; and

b) determining said reference head posture as a function of a movement or a position of at least one eyelid of the subject during the motion of his/her head at step a2).

2. Method according to claim 1, wherein, at step b), the at least one eyelid of the subject is his/her upper eyelid.

3. Method according to claim 2, wherein the reference head posture is determined at step b) as the posture adopted by the subject at an instant where said at least one upper eyelid stops, respectively starts, moving when the head of the subject is moving up, respectively is moving down.

4. Method according to claim 2, wherein the reference head posture is determined at step b) as the posture adopted by the subject at an instant where said at least one upper eyelid fits in, respectively get out of, an arch of the corresponding eyebrow of the subject, when the head of the subject is moving down, respectively is moving up.

5. Method according to anyone of claims 1 to 4, wherein, at step a1), the predetermined direction is the subject's gaze direction when he/she is looking at a fixed point straight ahead or at himself/herself in a mirror or on a display screen.

6. Method according to anyone of claims 1 to 5, wherein, at step b), said reference head posture is determined while observing visually or by means of a video camera the movement and/or the position of said

at least one eyelid of the subject.

7. Method for measuring a distinctive height (B) associated with a frame of a pair of spectacles worn, physically or virtually, by said subject, said method comprising the steps of:

- determining a reference head posture of the subject using a method of determination according to anyone of claims 1 to 6; and

- when the head of the subject is in said reference head posture, determining a measured value of said distinctive height as a function of the distance, along a vertical direction substantially perpendicular to the initial predetermined direction, between a center of one pupil of the subject and a bottom edge of said frame.

8. Method according to claim 7, wherein:

- one acquires, at step b) of the method of determination, a tilt angle of the head of the subject with respect to said vertical direction;

- one determines said distinctive height when the head of the subject is tilted with respect to said vertical direction by the acquired tilt angle.

9. Method according to claim 7 or 8, wherein one determines a real value of said distinctive height with an offset to the measured value.

10. Method according to claim 9, wherein said offset depends on subject's ethnicity.

11. Method according to anyone of claims 7 to 10, wherein, when the subject wears virtually said pair of spectacles, one positions said frame with respect to the head of the subject in accordance with a distance along said vertical direction between the eyebrows of the subject and a top edge of said frame.

12. Method according to anyone of claims 6 to 11, wherein one determines said measured value of the distinctive height in lighting conditions adapted to reduce the size of the pupil of the subject.

13. Method for verifying the mounting of at least one ophthalmic lens in a frame of a pair of spectacles designed to be worn by a subject, said method comprising the steps of:

- determining a reference head posture of the subject using a method of determination according to anyone of claims 1 to 6;

- capturing a first image of the frame when the subject is in said reference head posture and wears said frame without the at least one ophthalmic lens;

- mounting in said frame the at least one ophthalmic lens having a marking;
  - capturing a second image of the frame fitted with the at least one ophthalmic lens displaying said marking;
  - processing said first and second images so as to superimpose the images of the frame in both images;
  - determining a calculated value of the distance between said marking and a center of a pupil of an eye of the subject to be visually corrected with said ophthalmic lens;
  - comparing said calculated value with a threshold value; and
  - verifying the mounting of the at least one ophthalmic lens in the frame as a function of the previous comparison.
14. Apparatus (10) adapted to determine a reference head posture of a subject in accordance with the method of claim 1 comprising:
- image-capturing means (11) adapted to capture images or films of a movement or a position of at least one eyelid of the subject while he/she moves his/her head up and down starting from an initial head posture wherein he/she directs his/her gaze towards a predetermined direction, the subject keeping his/her gaze directed towards said predetermined direction during the motion of his/her head; and
  - image-processing means (12) configured to analyze the images or films captured by said image-capturing means and to determine said reference head posture as a function of the movement or the position of the at least one eyelid of the subject.
15. Apparatus (10) according to claim 14, wherein, said subject wearing physically or virtually a pair of spectacles:
- the image-capturing means (11) are adapted to capture at least one image of the subject when his/her head is in said reference head posture; and
  - the image-processing means (12) are further configured to analyze said at least one image and to determine a measured value of a distinctive height associated with a frame of said pair of spectacles as a function of the distance, along a vertical direction substantially perpendicular to the initial predetermined direction, between a center of one pupil of the subject and a bottom edge of said frame.

## Patentansprüche

1. Verfahren zur Bestimmung einer Referenzkopfhaltung einer Person, wobei das Verfahren die folgenden Schritte umfasst:
  - a) die Person auffordern:
    - a1) eine anfängliche Kopfhaltung einzunehmen, in der sie ihren Blick in eine vorgegebene Richtung lenkt;
    - a2) ihren Kopf nach unten und nach oben zu bewegen, ausgehend von der anfänglichen Kopfhaltung, während sie ihren Blick weiterhin in die vorgegebene Richtung lenkt; und
  - b) Bestimmen der Referenzkopfhaltung in Abhängigkeit von einer Bewegung oder einer Position mindestens eines Augenlids der Person während der Bewegung ihres Kopfes in Schritt a2).
2. Verfahren nach Anspruch 1, wobei in Schritt b) das mindestens eine Augenlid der Person ihr oberes Augenlid ist.
3. Verfahren nach Anspruch 2, wobei die Referenzkopfhaltung in Schritt b) als die Haltung bestimmt wird, die von der Person in einem Moment eingenommen wird, in dem das mindestens eine obere Augenlid aufhört bzw. beginnt sich zu bewegen, wenn der Kopf der Person sich nach oben bzw. nach unten bewegt.
4. Verfahren nach Anspruch 2, wobei die Referenzkopfhaltung in Schritt b) als die Haltung bestimmt wird, die von der Person in einem Moment eingenommen wird, in dem das mindestens eine obere Augenlid in einen Bogen der entsprechenden Augenbraue der Person passt bzw. außerhalb des Bogens liegt, wenn der Kopf der Person sich nach oben bzw. nach unten bewegt.
5. Verfahren nach einem der Ansprüche 1 bis 4, wobei in Schritt a1) die vorgegebene Richtung die Blickrichtung der Person ist, wenn sie geradeaus auf einen fixen Punkt blickt oder sich selbst in einem Spiegel oder auf einem Anzeigebildschirm anblickt.
6. Verfahren nach einem der Ansprüche 1 bis 5, wobei in Schritt b) die Referenzkopfhaltung bestimmt wird, während die Bewegung und/oder die Position des zumindest einen Augenlids der Person visuell oder mit einer Videokamera beobachtet wird.
7. Verfahren zur Messung einer charakteristischen Höhe (B) im Zusammenhang mit einem Gestell einer

Brille, die physikalisch oder virtuell von der Person getragen wird, wobei das Verfahren die folgenden Schritte umfasst:

- Bestimmen einer Referenzkopfhaltung der Person unter Verwendung eines Bestimmungsverfahrens nach einem der Ansprüche 1 bis 6; und
  - wenn sich der Kopf der Person in der Referenzkopfhaltung befindet, Bestimmen eines Messwerts der charakteristischen Höhe in Abhängigkeit vom Abstand entlang einer vertikalen Richtung im Wesentlichen senkrecht zur anfänglichen vorbestimmten Richtung zwischen einem Mittelpunkt einer Pupille der Person und einem unteren Rand des Gestells.
- 5  
10  
15
8. Verfahren nach Anspruch 7, wobei
- in Schritt b) des Bestimmungsverfahrens ein Neigungswinkel des Kopfes der Person bezüglich der vertikalen Richtung erfasst wird;
  - die charakteristische Höhe bestimmt wird, wenn der Kopf der Person bezüglich der vertikalen Richtung um den erfassten Neigungswinkel geneigt ist.
- 20  
25
9. Verfahren nach Anspruch 7 oder 8, wobei ein realer Wert der charakteristischen Höhe mit einem Versatz zum Messwert bestimmt wird.
- 30
10. Verfahren nach Anspruch 9, wobei der Versatz von der Ethnizität der Person abhängt.
- 35
11. Verfahren nach einem der Ansprüche 7 bis 10, wobei, wenn die Person die Brille virtuell trägt, das Gestell bezüglich des Kopfes der Person gemäß einem Abstand entlang der vertikalen Richtung zwischen den Augenbrauen der Person und einem oberen Rand des Gestells positioniert wird.
- 40
12. Verfahren nach einem der Ansprüche 6 bis 11, wobei der Messwert der charakteristischen Höhe unter Lichtbedingungen bestimmt wird, die zur Reduzierung der Größe der Pupille der Person angepasst sind.
- 45
13. Verfahren zur Verifizierung des Anbringens zumindest einer ophthalmischen Linse in einem Gestell einer Brille, die von einer Person getragen werden soll, wobei das Verfahren die folgenden Schritte umfasst:
- Bestimmen einer Referenzkopfhaltung der Person unter Verwendung eines Bestimmungsverfahrens nach einem der Ansprüche 1 bis 6;
  - Erfassen eines ersten Bilds des Gestells, wenn die Person die Referenzkopfhaltung eingenom-
- 50  
55

men hat und das Gestell ohne die zumindest eine ophthalmische Linse trägt;

- Anbringen der zumindest einen ophthalmischen Linse mit einer Markierung im Gestell;
- Erfassen eines zweiten Bilds des Gestells, an dem die zumindest eine ophthalmische Linse, die die Markierung aufweist, angebracht ist;
- Verarbeiten der ersten und zweiten Bilder, um die Bilder des Gestells in beiden Bildern zu überlagern;
- Bestimmen eines berechneten Werts des Abstands zwischen der Markierung und einem Mittelpunkt einer Pupille eines Auges der Person, das visuell mit der ophthalmischen Linse korrigiert werden soll;
- Vergleichen des berechneten Werts mit einem Schwellenwert; und
- Verifizieren des Anbringens der zumindest einen ophthalmischen Linse im Gestell in Abhängigkeit von dem vorherigen Vergleich.

14. Vorrichtung (10), die zur Bestimmung einer Referenzkopfhaltung einer Person mit dem Verfahren nach Anspruch 1 angepasst ist, umfassend:

- Bilderfassungsmittel (11), die zum Erfassen von Bildern oder Filmen einer Bewegung oder einer Position zumindest eines Augenlids der Person ausgelegt sind, während diese ausgehend von einer anfänglichen Kopfhaltung, in der sie ihren Blick in eine vorgegebene Richtung lenkt, ihren Kopf nach oben und unten bewegt, wobei die Person ihren Blick während der Bewegung ihres Kopfes weiterhin in die vorgegebene Richtung lenkt; und
- Bilderfassungsmittel (12), die zur Auswertung der von den Bilderfassungsmitteln erfassten Bilder oder Filme und zur Bestimmung der Referenzkopfhaltung in Abhängigkeit von der Bewegung oder der Position des zumindest einen Augenlids der Person ausgelegt sind.

15. Vorrichtung (10) nach Anspruch 14, wobei während die Person eine Brille physikalisch oder virtuell trägt:

- die Bilderfassungsmittel (11) zum Erfassen zumindest eines Bilds der Person, während ihr Kopf sich in der Referenzkopfhaltung befindet, ausgelegt sind; und
- die Bilderfassungsmittel (12) ferner zur Auswertung des zumindest einen Bilds und zur Bestimmung eines Messwerts einer charakteristischen Höhe im Zusammenhang mit einem Gestell der Brille in Abhängigkeit vom Abstand entlang einer vertikalen Richtung im Wesentlichen senkrecht zur anfänglichen vorgegebenen Richtung zwischen einem Mittelpunkt einer Pupille der Person und einem unteren Rand des

Gestells ausgelegt sind.

vement et/ou la position de ladite au moins une paupière du sujet.

## Revendications

1. Procédé permettant de déterminer une posture de tête de référence d'un sujet, ledit procédé comportant les étapes consistant à :

a) demander au sujet de :

a1) adopter une posture de tête initiale dans laquelle il/elle dirige son regard dans une direction prédéfinie ;

a2) déplacer sa tête vers le haut et vers le bas en commençant depuis ladite posture de tête initiale tout en gardant son regard dirigé dans ladite direction prédéfinie ; et

b) déterminer ladite posture de tête de référence en fonction d'un mouvement ou d'une position d'au moins une paupière du sujet pendant le mouvement de sa tête à l'étape a2).

2. Procédé selon la revendication 1, dans lequel, à l'étape b), l'au moins une paupière du sujet est sa paupière supérieure.

3. Procédé selon la revendication 2, dans lequel la posture de tête de référence est déterminée à l'étape b) comme étant la posture adoptée par le sujet à un instant où ladite au moins une paupière supérieure arrête de se déplacer lorsque la tête du sujet se déplace vers le haut, respectivement commence à se déplacer lorsque la tête du sujet se déplace respectivement vers le bas.

4. Procédé selon la revendication 2, dans lequel la posture de tête de référence est déterminée à l'étape b) comme étant la posture adoptée par le sujet à un instant où ladite au moins une paupière supérieure s'ajuste dans un arc du sourcil correspondant du sujet lorsque la tête du sujet se déplace vers le bas, respectivement sort d'un arc du sourcil correspondant du sujet lorsque la tête du sujet se déplace respectivement vers le haut.

5. Procédé selon l'une quelconque des revendications 1 à 4, dans lequel, à l'étape a1), la direction prédéfinie est la direction du regard du sujet lorsqu'il/elle regarde un point fixe droit devant lui/elle ou qu'il/elle se regarde dans un miroir ou sur un écran d'affichage.

6. Procédé selon l'une quelconque des revendications 1 à 5, dans lequel, à l'étape b), ladite posture de tête de référence est déterminée tout en observant visuellement ou au moyen d'une caméra vidéo le mou-

7. Procédé permettant de mesurer une hauteur distinctive (B) associée à une monture d'une paire de lunettes portée, physiquement ou virtuellement, par ledit sujet, ledit procédé comportant les étapes consistant à :

- déterminer une posture de tête de référence du sujet à l'aide d'un procédé de détermination selon l'une quelconque des revendications 1 à 6 ; et

- lorsque la tête du sujet est dans ladite posture de tête de référence, déterminer une valeur mesurée de ladite hauteur distinctive en fonction de la distance, le long d'une direction verticale sensiblement perpendiculaire à la direction prédéfinie initiale, entre un centre d'une pupille du sujet et un bord inférieur de ladite monture.

8. Procédé selon la revendication 7, dans lequel :

- on acquiert, à l'étape b) du procédé de détermination, un angle d'inclinaison de la tête du sujet par rapport à ladite direction verticale ;

- on détermine ladite hauteur distinctive lorsque la tête du sujet est inclinée par rapport à ladite direction verticale par l'angle d'inclinaison acquis.

9. Procédé selon la revendication 7 ou 8, dans lequel on détermine une valeur réelle de ladite hauteur distinctive avec un décalage par rapport à la valeur mesurée.

10. Procédé selon la revendication 9, dans lequel ledit décalage dépend de l'origine ethnique du sujet.

11. Procédé selon l'une quelconque des revendications 7 à 10, dans lequel, lorsque le sujet porte virtuellement ladite paire de lunettes, on positionne ladite monture par rapport à la tête du sujet en fonction d'une distance le long de ladite direction verticale entre les sourcils du sujet et un bord supérieur de ladite monture.

12. Procédé selon l'une quelconque des revendications 6 à 11, dans lequel on détermine ladite valeur mesurée de la hauteur distinctive dans des conditions d'éclairage conçues pour réduire la taille de la pupille du sujet.

13. Procédé permettant de vérifier le montage d'au moins un verre ophtalmique dans une monture d'une paire de lunettes conçue pour être portée par un sujet, ledit procédé comportant les étapes consistant à :

- déterminer une posture de tête de référence du sujet à l'aide d'un procédé de détermination selon l'une quelconque des revendications 1 à 6 ;
  - capturer une première image de la monture lorsque le sujet est dans ladite posture de tête de référence et porte ladite monture sans l'au moins un verre ophtalmique ; 5
  - monter dans ladite monture l'au moins un verre ophtalmique possédant un repère ; 10
  - capturer une seconde image de la monture pourvue de l'au moins un verre ophtalmique affichant ledit repère ;
  - traiter lesdites première et seconde images de façon à superposer les images de la monture dans les deux images ; 15
  - déterminer une valeur calculée de la distance entre ledit repère et un centre d'une pupille d'un œil du sujet devant être visuellement corrigé avec ledit verre ophtalmique ; 20
  - comparer ladite valeur calculée avec une valeur de seuil ; et
  - vérifier le montage de l'au moins un verre ophtalmique dans la monture en fonction de la comparaison précédente. 25
- 14.** Appareil (10) conçu pour déterminer une posture de tête de référence d'un sujet selon le procédé selon la revendication 1 comprenant : 30
- des moyens de capture d'images (11) conçus pour capturer des images ou des films d'un mouvement ou d'une position d'au moins une paupière du sujet pendant qu'il/elle déplace sa tête vers haut et vers le bas en commençant depuis une posture de tête initiale dans laquelle il/elle dirige son regard dans une direction prédéfinie, le sujet gardant son regard dirigé dans ladite direction prédéfinie pendant le mouvement de sa tête ; et 35
  - des moyens de traitement d'images (12) conçus pour analyser les images ou films capturés par lesdits moyens de capture d'images et pour déterminer ladite posture de tête de référence en fonction du mouvement ou de la position de l'au moins une paupière du sujet. 40
- 15.** Appareil (10) selon la revendication 14, dans lequel, ledit sujet portant physiquement ou virtuellement une paire de lunettes : 45
- les moyens de capture d'images (11) sont conçus pour capturer au moins une image du sujet lorsque sa tête est dans ladite posture de tête de référence ; et 50
  - les moyens de traitement d'images (12) sont en outre conçus pour analyser ladite au moins une image et pour déterminer une valeur mesu-

rée d'une hauteur distinctive associée à une monture de ladite paire de lunettes en fonction de la distance, le long d'une direction verticale sensiblement perpendiculaire à la direction prédéfinie initiale, entre un centre d'une pupille du sujet et un bord inférieur de ladite monture.

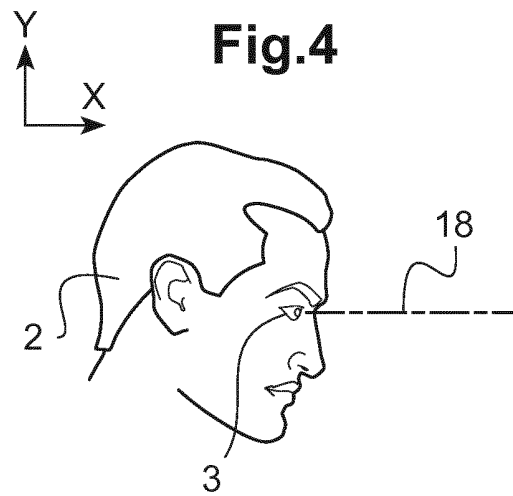
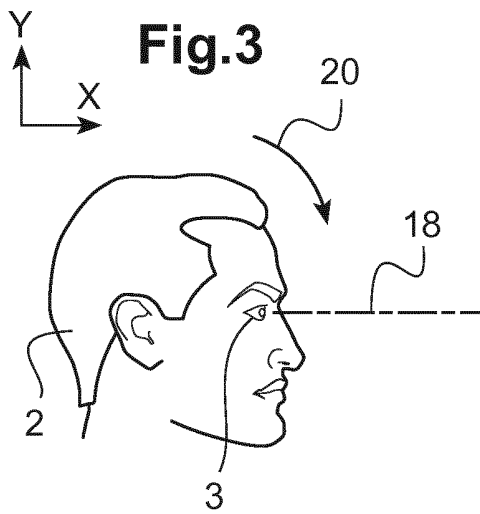
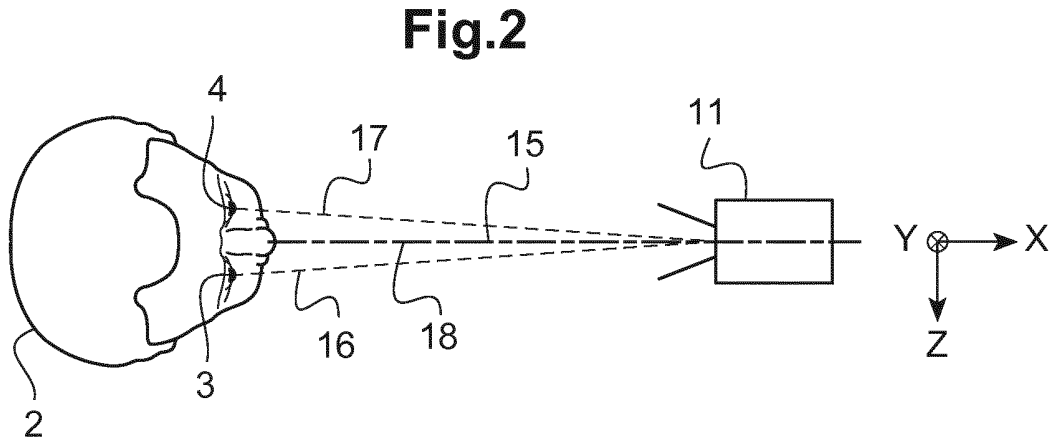
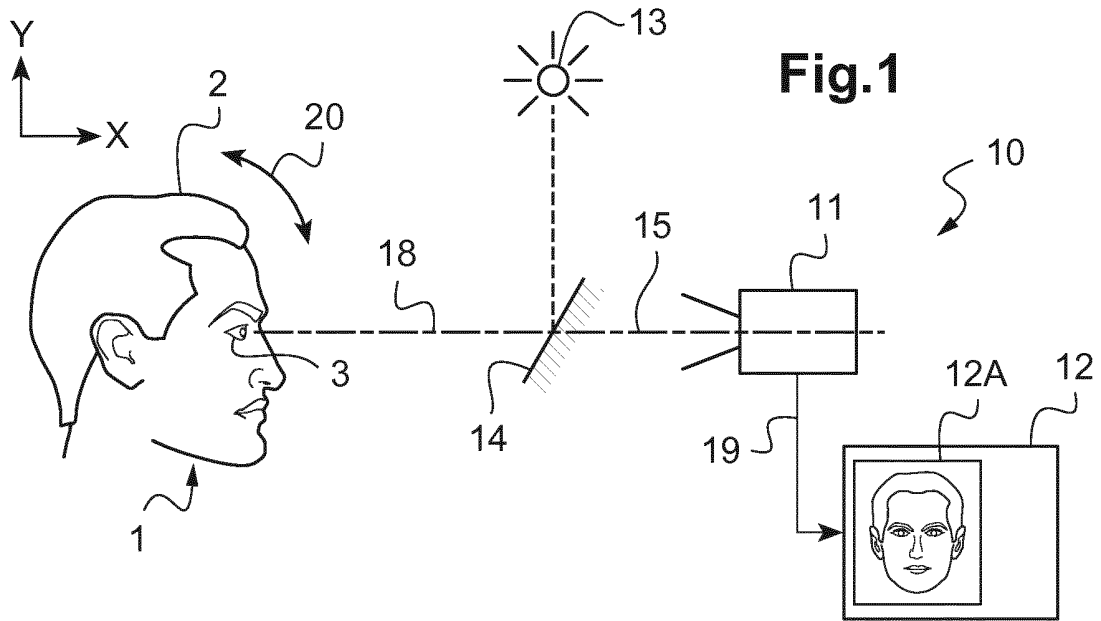

**Fig.5**

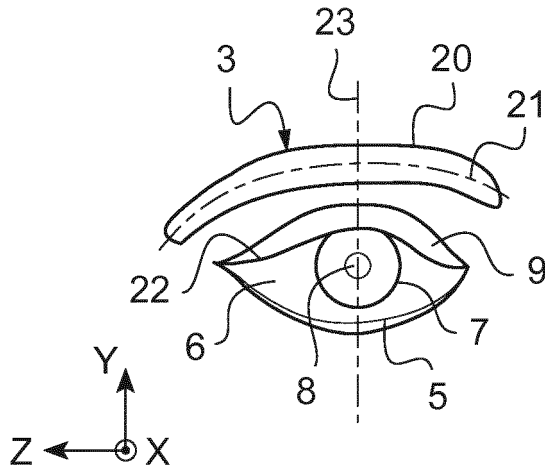

**Fig.6**

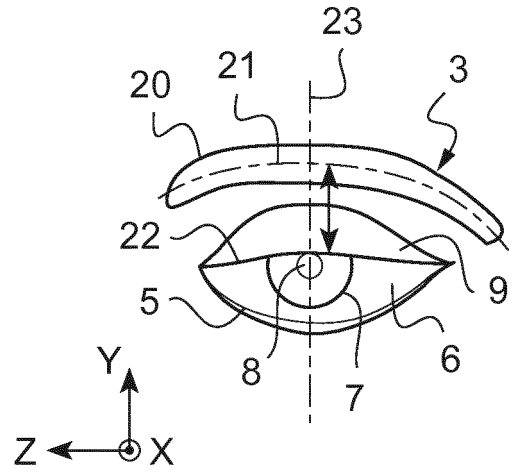

**Fig.7**

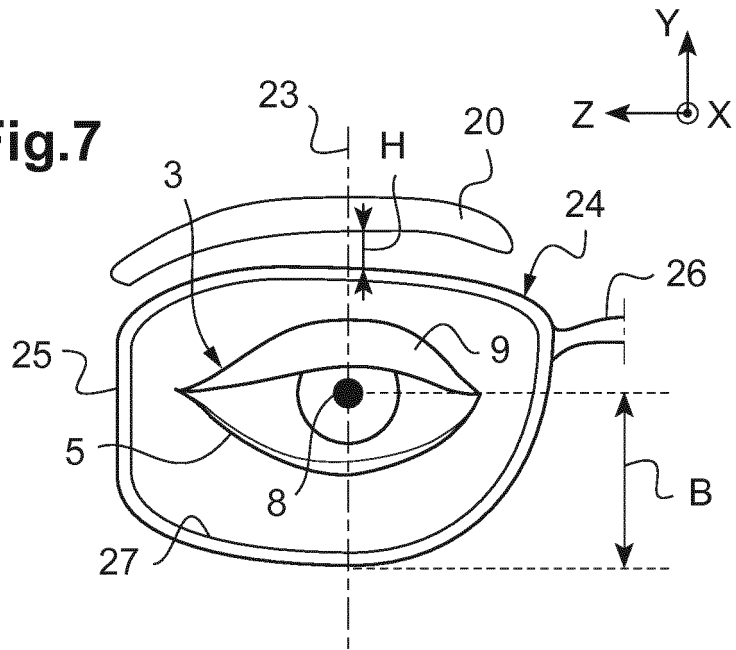

**REFERENCES CITED IN THE DESCRIPTION**

*This list of references cited by the applicant is for the reader's convenience only. It does not form part of the European patent document. Even though great care has been taken in compiling the references, errors or omissions cannot be excluded and the EPO disclaims all liability in this regard.*

**Patent documents cited in the description**

- WO 2010145736 A [0006]

专利名称(译)	确定一个人的参考头位置的方法和装置		
公开(公告)号	<a href="#">EP3494866B1</a>	公开(公告)日	2020-02-26
申请号	EP2017306716	申请日	2017-12-06
[标]申请(专利权)人(译)	埃西勒国际通用光学公司		
申请(专利权)人(译)	ESSILOR INTERNATIONAL		
当前申请(专利权)人(译)	ESSILOR INTERNATIONAL		
[标]发明人	LE SAUX GILLES		
发明人	LE SAUX, GILLES		
IPC分类号	A61B3/00 A61B3/113 G02C7/02 A61B5/00 G02C13/00 A61B3/11		
CPC分类号	A61B3/0025 A61B3/11 A61B3/113 A61B5/4561 G02C13/005		
其他公开文献	EP3494866A1		
外部链接	<a href="#">Espacenet</a>		

摘要(译)

本发明涉及一种用于确定对象(1)的参考头部姿势的方法和装置,所述方法包括以下步骤:a)要求对象:a1)采用初始头部姿势,其中他/她指导他/她的视线朝向预定方向(18);a2)在步骤a1)中从所述初始头部姿势开始上下移动他/她的头部(2),同时保持他/她的视线朝向所述预定方向;在步骤a2)中,根据对象的至少一个眼皮的运动或位置确定所述参考头部姿势。此外,本发明还提出了一种用于测量特征性身高的方法最后,本发明涉及一种用于在眼镜的框架中安装和检验眼镜片的安装的方法。

