

(19)



(11)

EP 3 479 267 B1

(12)

EUROPEAN PATENT SPECIFICATION

(45) Date of publication and mention of the grant of the patent:
27.05.2020 Bulletin 2020/22

(51) Int Cl.:
G16H 20/17 (2018.01) G16H 50/20 (2018.01)
A61B 5/145 (2006.01) A61B 5/00 (2006.01)

(21) Application number: **17735028.7**

(86) International application number:
PCT/EP2017/065379

(22) Date of filing: **22.06.2017**

(87) International publication number:
WO 2018/001853 (04.01.2018 Gazette 2018/01)

(54) REGIMEN ADHERENCE MEASURE FOR INSULIN TREATMENT BASED ON GLUCOSE MEASUREMENTS AND INSULIN PEN DATA

BEHANDLUNGSEINHALTUNGSMESSUNG FÜR INSULINBEHANDLUNG AUF BASIS VON BLUTZUCKERMESSUNGEN UND INSULINSTIFTDATEN

MESURE D'ADHÉRENCE D'UN RÉGIME POUR TRAITEMENT À L'INSULINE SUR LA BASE DE MESURES DE GLUCOSE ET DONNÉES DE STYLO D'INSULINE

(84) Designated Contracting States:
AL AT BE BG CH CY CZ DE DK EE ES FI FR GB GR HR HU IE IS IT LI LT LU LV MC MK MT NL NO PL PT RO RS SE SI SK SM TR
Designated Validation States:
MA

(73) Proprietor: **Novo Nordisk A/S**
2880 Bagsværd (DK)

(30) Priority: **30.06.2016 EP 16177080**

(72) Inventors:
• **BENGTSSON, Henrik**
2880 Bagsværd (DK)
• **ARADÓTTIR, Tinna, Björk**
2880 Bagsværd (DK)

(43) Date of publication of application:
08.05.2019 Bulletin 2019/19

(56) References cited:
WO-A1-2012/152628 US-A1- 2014 019 396
US-A1- 2015 006 462

EP 3 479 267 B1

Note: Within nine months of the publication of the mention of the grant of the European patent in the European Patent Bulletin, any person may give notice to the European Patent Office of opposition to that patent, in accordance with the Implementing Regulations. Notice of opposition shall not be deemed to have been filed until the opposition fee has been paid. (Art. 99(1) European Patent Convention).

Description

TECHNICAL FIELD

[0001] The present disclosure relates generally to systems and methods for assisting patients and health care practitioners in managing insulin delivery to diabetic patients.

BACKGROUND

[0002] Type 2 diabetes mellitus is characterized by progressive disruption of normal physiologic insulin secretion. In healthy individuals, basal insulin secretion by pancreatic β cells occurs continuously to maintain steady glucose levels for extended periods between meals. Also in healthy individuals, there is prandial secretion in which insulin is rapidly released in an initial first-phase spike in response to a meal, followed by prolonged insulin secretion that returns to basal levels after 2-3 hours.

[0003] Insulin is a hormone that binds to insulin receptors to lower blood glucose by facilitating cellular uptake of glucose, amino acids, and fatty acids into skeletal muscle and fat and by inhibiting the output of glucose from the liver. In normal healthy individuals, physiologic basal and prandial insulin secretions maintain euglycemia, which affects fasting plasma glucose and postprandial plasma glucose concentrations. Basal and prandial insulin secretion is impaired in Type 2 diabetes and early post-meal response is absent. To address these adverse events, patients with Type 2 diabetes are provided with insulin treatment regimens. Patients with Type 1 diabetes are also provided with insulin treatment regimens.

[0004] Some diabetic patients only need a basal insulin treatment regimen to make up for deficiencies in pancreatic β cells insulin secretion. Some patients need both basal insulin treatment and bolus insulin treatment. Thus, patients that require both basal insulin treatment and bolus insulin treatment take a periodic basal insulin medicament treatment, for instance once or twice a day, as well as one or more bolus insulin medicament treatments with meals.

[0005] The goal of these insulin treatment regimens is to achieve steady glucose levels. The success of an insulin treatment regimen in a subject can be deduced by taking continuous glucose level measurements of a subject or by measuring HbA1c levels. The term "HbA1c" refers to glycated haemoglobin. It develops when haemoglobin, a protein within red blood cells that carries oxygen throughout the body, joins with glucose in the blood, thus becoming "glycated." By measuring glycated haemoglobin (HbA1c), health care practitioners are able to get an overall picture of average glucose levels over a period of weeks/months. For people with diabetes, the higher the HbA1c, the greater the risk of developing diabetes-related complications

[0006] Insulin treatment regimen nonadherence is a barrier for diabetes patients to reaching suitable HbA1c

goals. Adherence is typically defined as the degree to which a patient correctly follows medical advice (e.g., a standing insulin regimen for a subject comprising at least a basal insulin medicament dosage regimen), but can also be, for example, consistency in diet and exercise. The reasons for nonadherence are many and different. One reason for nonadherence is poor health literacy and comprehension of treatment. Patients fail to understand glucose measurement results, lack positive feedback when adherent, or feel a lack of urgency. Another reason for nonadherence is the fear of side effects. For instance, the fear of hypoglycaemia if the patient strictly adheres to the standing insulin regimen. Yet another reason for nonadherence is the hassle and time-consuming aspect of conventional standing insulin regimens, which often entail home-logging data and frequent injections and glucose measurements.

[0007] Patients on insulin pen treatment typically use blood glucose monitors, and need to home-log measurements and injections in order to adhere to standing insulin regimens. These home-logged data tend to be unreliable due to several reasons. In some instances, patients hide regimen nonadherence by filling in better (lower) blood glucose measurements than observed or non-taken insulin injections as taken. In some instances, patients do not regularly fill out log-books and therefore do so by memory the evening before a meeting with a health care practitioner.

[0008] As such, health care practitioners are forced to navigate with home-logged data which poses difficulty in pinpointing where and why treatment is going wrong. Moreover, the unreliability of home-logged data can lead to adverse events. For instance, the health care practitioner may up-titrate a basal insulin medicament when the patient exhibits fasting blood glucose measurements that are too high. Yet, this may lead to the adverse event of overdosing of the insulin medicament and hypoglycemia when the blood glucose measurements were in fact due to forgotten basal or bolus insulin medicament injections, as opposed to an insulin regimen that did not call for adequate insulin medicament dosing. Also, the patient may log as non-taken insulin medicament doses as taken. When this is not reflected in glucose levels measured in the clinic (and/or HbA1c levels measured from such glucose levels), the health care practitioner may increase insulin medicament dosage in the standing insulin regimen for this basis and thus the patient's dosage regimen can therefore indicate a dangerously high insulin dose, if injected, leading to overdosing of the insulin medicament and hypoglycemia.

[0009] Given the inadequacy with patient recorded records disclosed above, what is needed in the art are systems and methods that provide more robust insulin titration methods that achieve target glucose levels.

[0010] US2015/006462A1 discloses management of a patient's medical adherence to a regimen.

[0011] WO2012/152628A1 discloses optimization of basal insulin dosage regimen using data derived from

timestamped blood glucose values, administered dose and an initial insulin dosage regimen.

SUMMARY

[0012] In the disclosure of the present invention, embodiments and aspects will be described, which will address one or more of the above objects or which will address objects apparent from the below disclosure as well as from the description of exemplary embodiments.

[0013] The present disclosure addresses the above-identified need in the art by providing a patient and/or health care practitioner with ways to monitor adherence with a standing insulin regimen and to thereby enable the pinpointing how adherence, and to what degree, regimen adherence affects the treatment results for the patient. As such, the present disclosure relates to analyzing autonomous glucose measurements and insulin pen data of a patient, and potentially more data, such as from wearables, to assist health care practitioners and/or the patient in obtaining treatment transparency. In one aspect of the present disclosure, systems and methods are provided for adjusting a standing insulin medicament dosage regimen for a subject. Fasting events are identified using autonomous timestamped glucose measurements of the subject in a first data set. Further, a second data set is obtained from one or more insulin pens used to apply the standing regimen to the subject. This second data set comprises records. Each record comprises a timestamped event specifying an amount of injected insulin medicament that the subject injected as part of the standing insulin medicament dosage regimen. Each fasting event is characterized as adherent or nonadherent. A fasting event is adherent when the second data set includes one or more records that temporally and quantitatively establish adherence with the standing regimen during the fasting event. Conversely, a fasting event is nonadherent when the second data set fails to temporally and quantitatively establish adherence with the standing regimen. Dosages in the standing regimen are adjusted using glucose measurements contemporaneous with adherent fasting events and by specifically excluding glucose measurements contemporaneous with nonadherent fasting events. This helps to overcome inaccuracies that arise in conventional home-logged insulin treatment data. In a further aspect the standing insulin regimen comprises a bolus insulin medicament dosage regimen, each respective insulin medicament injection event in the plurality of medicament records further indicates a respective type of insulin medicament injected into the subject from one of (i) a long acting insulin medicament and (ii) a short acting insulin medicament, and the method further comprises: identifying a plurality of meal events using the plurality of autonomous glucose measurements and the corresponding timestamps in the first data set, and applying a second characterization to each respective meal event in the plurality of meal events. The second characterization is one of a bolus regimen ad-

herent and a bolus regimen nonadherent, a respective meal is deemed bolus regimen adherent when one or more medicament records in the plurality of medicament records indicates, on a temporal basis, a quantitative basis and a type of insulin medicament basis, adherence with the standing bolus insulin medicament dosage regimen during the respective meal. A respective meal is deemed bolus regimen nonadherent when the plurality of medicament records fails to indicate adherence, on a temporal basis, a quantitative basis, and a type of insulin medicament basis, with the standing bolus insulin medicament dosage regimen during the respective meal. The method further comprises adjusting insulin medicament dosage in the standing insulin medicament regimen for the subject by using glucose measurements in the first data set that are temporally associated with meal events that are deemed bolus regimen adherent and by excluding glucose measurements in the first data set that are temporally associated with meal events that are deemed bolus regimen nonadherent.

[0014] In a further aspect the method comprises adjusting insulin medicament dosage in the bolus insulin medicament dosage regimen for the subject by using glucose measurements in the first data set that are temporally associated with meal events that are deemed bolus regimen adherent and by excluding glucose measurements in the first data set that are temporally associated with meal events that are deemed bolus regimen nonadherent.

[0015] In a further aspect the method comprises adjusting insulin medicament dosage in the basal insulin medicament dosage regimen for the subject by using glucose measurements in the first data set that are temporally associated with meal events that are deemed bolus regimen adherent and by excluding glucose measurements in the first data set that are temporally associated with meal events that are deemed bolus regimen nonadherent.

[0016] In a further aspect, the device further comprising a wireless receiver, and wherein the first data set is obtained wirelessly from a glucose sensor affixed to the subject and/or the second data set is obtained wirelessly from the one or more insulin pens.

[0017] In a further aspect, the first data set further comprises a plurality of feed-forward events, each respective feed-forward event in the plurality of feed-forward events represents an instance where the subject has indicated they are having or are about to have a meal, and the plurality of meal events are verified against the plurality of feed-forward events by either removing any respective meal event in the plurality of meal events that fails to temporally match any feed-forward event in the plurality of feed-forward events.

[0018] In a further aspect successive measurements in the plurality of autonomous glucose measurements are taken from the subject at an interval rate of 5 minutes or less, 3 minutes or less, or 1 minute or less.

[0019] In a further aspect the basal regimen is associ-

ated with a plurality of epochs, the basal regimen specifies that a basal dose of long acting insulin medicament is to be taken during each respective epoch in the plurality of epochs, and a respective fasting event is deemed basal regimen nonadherent, when there are no medicament records in the second data set for the epoch associated with the respective fasting event.

[0020] In a further aspect each epoch in the plurality of epochs is one week or less, two days or less, one day or less, or 12 hours or less.

[0021] In a further aspect, the bolus insulin medicament dosage regimen specifies that the short acting insulin medicament is to be taken up to a predetermined amount of time prior to or after a meal, and a respective meal is deemed bolus regimen nonadherent when there is no insulin medicament record of the short acting insulin medicament type having an electronic timestamp up to the predetermined amount of time prior to or after the respective meal.

[0022] In a further aspect, the predetermined amount of time is thirty minutes or less, twenty minutes or less, or fifteen minutes or less.

[0023] In a further aspect, the long acting insulin medicament consists of a single insulin medicament having a duration of action that is between 12 and 24 hours or a mixture of insulin medicaments that collectively have a duration of action that is between 12 and 24 hours, and the short acting insulin medicament consists of a single insulin medicament having a duration of action that is between three to eight hours or a mixture of insulin medicaments that collectively have a duration of action that is between three to eight hours.

[0024] In an other aspect, the long acting insulin medicament consists of a single insulin medicament having a duration of action that is between 24 hours and one a week.

[0025] In a further aspect the identifying the plurality of meal events is performed by computing:

- (i) a first model comprising a backward difference estimate of glucose rate of change using the plurality of autonomous glucose measurements,
- (ii) a second model comprising a backward difference estimate of glucose rate of change based on Kalman filtered estimates of glucose using the plurality of autonomous glucose measurements,
- (iii) a third model comprising a Kalman filtered estimate of glucose and Kalman filtered estimate of rate of change (ROC) of glucose based on the plurality of autonomous glucose measurements, or
- (iv) a fourth model comprising a Kalman filtered estimate of rate of change of ROC of glucose based on the plurality of autonomous glucose measurements.

[0026] In a further aspect, the first model, the second model, the third model and the fourth model are each computed across the plurality of autonomous glucose

measurements and each respective meal event in the plurality of meal events is identified at an instance where at least three of the four models indicates a meal event.

[0027] In a further aspect, the method further comprises repeating the method on an ongoing basis over time.

[0028] In a further aspect, the identifying the plurality of fasting events comprises identifying a first fasting period in a first time period encompassed by the plurality of autonomous glucose measurements by:

computing a moving period of variance σ_k^2 across the plurality of autonomous glucose measurements, wherein:

$$\sigma_k^2 = \left(\frac{1}{M} \sum_{i=k-M}^k (G_i - \bar{G}) \right)^2$$

wherein,

G_i is the i^{th} autonomous glucose measurement in a portion k of the plurality of autonomous glucose measurements,

M is a number of autonomous glucose measurements in the plurality of glucose measurements and represents a contiguous predetermined time span,

\bar{G} is the mean of the autonomous glucose measurements selected from the plurality of autonomous glucose measurements, and k is within the first time period; and

associating the first fasting period with a period of

minimum variance $\min_k \sigma_k^2$ within the first period.

[0029] In another aspect of the present disclosure, a computer program is provided comprising instructions that, when executed by one or more processors, perform a method comprising:

obtaining a first data set, the first data set comprising a plurality of autonomous glucose measurements of the subject and, for each respective autonomous glucose measurement in the plurality of autonomous glucose measurements, a timestamp representing when the respective measurement was made;

obtaining a second data set from one or more insulin pens used by the subject to apply the standing insulin regimen, the second data set comprising a plurality of insulin medicament records, each insulin medicament record in the plurality of medicament records comprising: (i) a respective insulin medicament injection event including an amount of insulin medica-

ment injected into the subject using a respective insulin pen in the one or more insulin pens and (ii) a corresponding electronic timestamp that is automatically generated by the respective insulin pen upon occurrence of the respective insulin medicament injection event;

identifying a plurality of fasting events using the plurality of autonomous glucose measurements of the subject and the respective timestamps in the first data set;

applying a first characterization to each respective fasting event in the plurality of fasting events, wherein

the first characterization is one of basal regimen adherent and basal regimen nonadherent,

a respective fasting event is deemed basal regimen adherent when the second data set includes one or more medicament records that establish, on a temporal and quantitative basis, adherence with the standing basal insulin medicament dosage regimen during the respective fasting event, and

a respective fasting event is deemed basal regimen nonadherent when the second data set fails to include one or more medicament records that establish, on a temporal and quantitative basis, adherence with the standing basal insulin medicament dosage regimen during the respective fasting event; and

adjusting insulin medicament dosage in the basal insulin medicament dosage regimen for the subject based upon glucose measurements in the first data set that are contemporaneous with the fasting events that are deemed basal regimen adherent and by excluding glucose measurements in the first data set that are contemporaneous with fasting events that are deemed basal regimen nonadherent.

[0030] In a further aspect is provided a computer-readable data carrier having stored thereon the computer program.

BRIEF DESCRIPTION OF THE DRAWINGS

[0031]

Figure 1 illustrates an exemplary system topology that includes a device for adjusting a standing insulin regimen for a subject, one or more glucose sensors that autonomously measure glucose data from the subject, and one or more insulin pens that are used by the subject to inject insulin medicaments in ac-

cordance with a standing insulin regimen, where the one or more glucose sensors, the one or more insulin pens, and the device are interconnected, optionally through a communications network, in accordance with an embodiment of the present disclosure.

Figure 2 illustrates a device for adjusting a standing insulin regimen for a subject in accordance with an embodiment of the present disclosure.

Figure 3 illustrates a device for adjusting a standing insulin regimen for a subject in accordance with another embodiment of the present disclosure.

Figures 4A, 4B, 4C, and 4D collectively provide a flow chart of processes and features of a device for adjusting a standing insulin regimen for a subject in accordance with various embodiments of the present disclosure.

Figure 5 illustrates an example integrated system of connected insulin pen, continuous glucose monitor, memory and a processor for performing algorithmic categorization of autonomous glucose data in accordance with an embodiment of the present disclosure.

Figure 6 illustrates an algorithm for calculating bolus insulin medicament regimen adherence, in which autonomous glucose measurements (BG data) and bolus insulin medicament injection event (Bolus insulin data) are inputs, and a meal detection algorithm is used to analyze the autonomous glucose measurements and determine whether a meal was detected or not, in accordance with an embodiment of the present disclosure.

Figure 7 illustrates an example of a disclosed bolus event marking algorithm, in which insulin medicament injection events are marked as either "Adherent" or "Not Adherent," in accordance with an embodiment of the present disclosure.

Figure 8 discloses an example of bolus adherence data interpretation in accordance with an embodiment of the present disclosure.

Figure 9 illustrates an algorithm for calculating basal insulin medicament dosage regimen adherence in which autonomous glucose measurements (BG data) and basal insulin medicament injection events (Basal insulin data) are used as inputs, and where, when a fasting period is detected (e.g. period of minimum variance), the period is classified as "fasting," and where the algorithm checks if a basal injection event has occurred within a period of time specified a standing basal insulin medicament dosage regimen before the fasting event (e.g. basal regimen

states one basal injection per day then the algorithm checks if the proper basal insulin medicament was taken during the 24 hours before the detected fasting period) and marks the fasting period as "Basal Adherent" if so, and "Not Basal Adherent" otherwise.

Figure 10 illustrates an example of basal event marking using the algorithm of Figure 9 in which basal insulin medicament events are marked as either "Basal Adherent" or "Not Basal Adherent" in accordance with some embodiments.

Figure 11 illustrates an example of basal regimen adherence data interpretation in accordance with an embodiment of the present disclosure.

Figure 12 illustrates the simulation of autonomous glucose data where no knowledge on insulin injection data is available.

Figure 13 illustrates the simulation of autonomous glucose data and bolus insulin medicament injections where insulin injection data is available and periods of regimen nonadherence with respect to bolus injection are marked in accordance with some embodiments.

[0032] Like reference numerals refer to corresponding parts throughout the several views of the drawings.

DETAILED DESCRIPTION

[0033] Figure 5 illustrates an example of an integrated system of one or more connected insulin pens, one or more continuous glucose monitors, memory and a processor for performing algorithmic categorization of autonomous glucose data of a subject in accordance with an embodiment of the present disclosure. Autonomous timestamped glucose measurements of the subject are obtained in a first data set 220. A second data set 228 is obtained from one or more insulin pens used to apply the standing regimen to the subject. This second data set comprises records. Each record comprises a timestamped event specifying an amount of injected insulin medicament that the subject injected as part of the standing insulin medicament dosage regimen. Fasting events are identified using autonomous timestamped glucose measurements of the subject in a first data set 502. Optionally meal events are also identified using the autonomous timestamped glucose measurements 502. In this way, the glucose measurements are filtered 504 and stored in memory 506. Each fasting event is characterized as adherent or nonadherent 508. A fasting event is adherent when the second data set includes one or more records that temporally and quantitatively establish adherence with a standing regimen during the fasting event. Conversely, a fasting event is nonadherent when the second data set fails to temporally and quantitatively estab-

lish adherence with the standing regimen. A respective meal is deemed bolus regimen adherent when one or more medicament records in the plurality of medicament records indicates, on a temporal basis, a quantitative basis and a type of insulin medicament basis, adherence with the standing bolus insulin medicament dosage regimen during the respective meal. A respective meal is deemed bolus regimen nonadherent when the plurality of medicament records fails to indicate adherence, on a temporal basis, a quantitative basis, and a type of insulin medicament basis, with the standing bolus insulin medicament dosage regimen during the respective meal. Finally, the filtered and cataloged glucose data is analyzed and visualized 510. Such visualization enables dosages in the standing regimen to be adjusted using glucose measurements contemporaneous with adherent fasting events and by specifically excluding glucose measurements contemporaneous with nonadherent fasting events. This helps to overcome inaccuracies that arise in conventional home-logged insulin treatment data.

[0034] Reference will now be made in detail to embodiments, examples of which are illustrated in the accompanying drawings. In the following detailed description, numerous specific details are set forth in order to provide a thorough understanding of the present disclosure. However, it will be apparent to one of ordinary skill in the art that the present disclosure may be practiced without these specific details. In other instances, well-known methods, procedures, components, circuits, and networks have not been described in detail so as not to unnecessarily obscure aspects of the embodiments.

[0035] It will also be understood that, although the terms first, second, etc. may be used herein to describe various elements, these elements should not be limited by these terms. These terms are only used to distinguish one element from another. For example, a first subject could be termed a second subject, and, similarly, a second subject could be termed a first subject, without departing from the scope of the present disclosure. The first subject and the second subject are both subjects, but they are not the same subject. Furthermore, the terms "subject" and "user" are used interchangeably herein. By the term insulin pen is meant an injection device suitable for applying discrete doses of insulin, and wherein the injection device is adapted for logging and communicating dose related data.

[0036] The terminology used in the present disclosure is for the purpose of describing particular embodiments only and is not intended to be limiting of the invention. As used in the description of the invention and the appended claims, the singular forms "a", "an" and "the" are intended to include the plural forms as well, unless the context clearly indicates otherwise. It will also be understood that the term "and/or" as used herein refers to and encompasses any and all possible combinations of one or more of the associated listed items. It will be further understood that the terms "comprises" and/or "comprising," when used in this specification, specify the presence

of stated features, integers, steps, operations, elements, and/or components, but do not preclude the presence or addition of one or more other features, integers, steps, operations, elements, components, and/or groups thereof.

[0037] As used herein, the term "if" may be construed to mean "when" or "upon" or "in response to determining" or "in response to detecting," depending on the context. Similarly, the phrase "if it is determined" or "if [a stated condition or event] is detected" may be construed to mean "upon determining" or "in response to determining" or "upon detecting [the stated condition or event]" or "in response to detecting [the stated condition or event]," depending on the context.

[0038] A detailed description of a system 48 for adjusting a standing insulin regimen 206 for a subject in accordance with the present disclosure is described in conjunction with Figures 1 through 3. As such, Figures 1 through 3 collectively illustrate the topology of the system in accordance with the present disclosure. In the topology, there is a device for adjusting a standing insulin regimen 200 for a subject (Figures 1, 2, and 2), one or more glucose sensors associated with the subject (Figure 1), and one or more insulin pens for injecting insulin medicaments into the subject (Figure 1).

[0039] Referring to Figure 1, there is device 200 for adjusting a standing insulin regimen of a subject. To do this, the device 200 receives autonomous glucose measurements from a glucose sensor 102 attached to the subject on an ongoing basis. Further, the device 200 receives insulin medicament injection data from one or more insulin pens used by the subject to inject insulin medicaments. As disclosed herein in further detail, in some embodiments the device 200 receives this data wirelessly through radio-frequency signals. In some embodiments such signals are in accordance with an 802.11, Bluetooth, or ZigBee standard. In some embodiments, the device 200 is not proximate to the subject and/or does not have wireless capabilities or such wireless capabilities are not used for the purpose of acquiring glucose data and insulin medicament injection data. In such embodiments a communication network 106 may be used to communicate glucose measurements from the glucose sensor 102 to the device 200 and from the insulin pens 104 to the device 200.

[0040] Examples of networks 106 include, but are not limited to, the World Wide Web (WWW), an intranet and/or a wireless network, such as a cellular telephone network, a wireless local area network (LAN) and/or a metropolitan area network (MAN), and other devices by wireless communication. The wireless communication optionally uses any of a plurality of communications standards, protocols and technologies, including but not limited to Global System for Mobile Communications (GSM), Enhanced Data GSM Environment (EDGE), high-speed downlink packet access (HSDPA), high-speed uplink packet access (HSUPA), Evolution, Data-Only (EV-DO), HSPA, HSPA+, Dual-Cell HSPA (DC-

HSDPA), long term evolution (LTE), near field communication (NFC), wideband code division multiple access (W-CDMA), code division multiple access (CDMA), time division multiple access (TDMA), Bluetooth, Wireless Fidelity (Wi-Fi) (e.g., IEEE 802.11a, IEEE 802.11ac, IEEE 802.11ax, IEEE 802.11b, IEEE 802.11g and/or IEEE 802.11n), voice over Internet Protocol (VoIP), Wi-MAX, a protocol for e-mail (e.g., Internet message access protocol (IMAP) and/or post office protocol (POP)), instant messaging (e.g., extensible messaging and presence protocol (XMPP), Session Initiation Protocol for Instant Messaging and Presence Leveraging Extensions (SIMPLE), Instant Messaging and Presence Service (IMPS)), and/or Short Message Service (SMS), or any other suitable communication protocol, including communication protocols not yet developed as of the filing date of this document.

[0041] In some embodiments the device 200 is part of the glucose sensor 102. That is, in some embodiments, the device 200 and the glucose sensor 102 are a single device.

[0042] In some embodiments the device 200 is part of the insulin pen. That is, in some embodiments, the device 200 and an insulin pen 104 are a single device.

[0043] Of course, other topologies of system 48 are possible. For instance, rather than relying on a communications network 106, the glucose sensor 102 and insulin pens may wirelessly transmit information directly to the device 200. Further, device 200 may constitute a portable electronic device, a server computer, or in fact constitute several computers that are linked together in a network or be a virtual machine in a cloud computing context. As such, the exemplary topology shown in Figure 1 merely serves to describe the features of an embodiment of the present disclosure in a manner that will be readily understood to one of skill in the art.

[0044] Referring to Figure 2, in typical embodiments, the device for adjusting a standing insulin regimen 200 comprises one or more computers. For purposes of illustration in Figure 2, the device 200 is represented as a single computer that includes all of the functionality for adjusting a standing insulin regimen. However, the disclosure is not so limited. The functionality for adjusting a standing insulin regimen may be spread across any number of networked computers and/or reside on each of several networked computers and/or by hosted on one or more virtual machines at a remote location accessible across the communications network 106. One of skill in the art will appreciate that a wide array of different computer topologies are possible for the application and all such topologies are within the scope of the present disclosure.

[0045] Turning to Figure 2 with the foregoing in mind, an exemplary device for adjusting a standing insulin regimen comprises one or more processing units (CPU's) 274, a network or other communications interface 284, a memory 192 (e.g., random access memory), one or more magnetic disk storage and/or persistent devices

290 optionally accessed by one or more controllers 288, one or more communication buses 212 for interconnecting the aforementioned components, and a power supply 276 for powering the aforementioned components. Data in memory 192 can be seamlessly shared with non-volatile memory 290 using known computing techniques such as caching. Memory 192 and/or memory 290 can include mass storage that is remotely located with respect to the central processing unit(s) 274. In other words, some data stored in memory 192 and/or memory 290 may in fact be hosted on computers that are external to the device 200 but that can be electronically accessed by the device 200 over an Internet, intranet, or other form of network or electronic cable (illustrated as element 106 in Figure 2) using network interface 284.

[0046] The memory 192 of the device 200 for adjusting a standing insulin regimen 206 for a subject stores:

- an operating system 202 that includes procedures for handling various basic system services;
- an insulin regimen adjustment module 204;
- a standing insulin regimen 206 for a subject, the standing insulin regimen comprising a basal insulin medicament dosage regimen 208 and, optionally in some embodiments, a bolus insulin medicament dosage regimen 214;
- a first data set 220, the first data set comprising a plurality of autonomous glucose measurements of the subject and, for each respective autonomous glucose measurement 222 in the plurality of autonomous glucose measurements, a timestamp 224 representing when the respective measurement was made, as well as optionally, a plurality of feed-forward events 226;
- a second data set 228 comprising a plurality of insulin medicament records for a subject, each insulin medicament record 230 in the plurality of medicament records comprising: (i) a respective insulin medicament injection event 232 including an amount of insulin medicament injected 234 into the subject using a respective insulin pen in one or more insulin pens (ii) a corresponding electronic timestamp 238 that is automatically generated by a respective insulin pen 104 upon occurrence of the respective insulin medicament injection event, and optionally an insulin medicament type 236;
- a plurality of fasting events 240 determined for the subject; and
- a plurality of meal events 246 determined for the subject.

[0047] In some embodiments, the insulin regimen adjustment module 204 is accessible within any browser (phone, tablet, laptop/desktop). In some embodiments the insulin regimen adjustment module 204 runs on native device frameworks, and is available for download onto the device 200 running an operating system 202 such as Android or iOS.

[0048] In some implementations, one or more of the above identified data elements or modules of the device 200 for adjusting a standing insulin regimen of a subject 206 are stored in one or more of the previously described memory devices, and correspond to a set of instructions for performing a function described above. The above-identified data, modules or programs (e.g., sets of instructions) need not be implemented as separate software programs, procedures or modules, and thus various subsets of these modules may be combined or otherwise re-arranged in various implementations. In some implementations, the memory 192 and/or 290 optionally stores a subset of the modules and data structures identified above. Furthermore, in some embodiments the memory 192 and/or 290 stores additional modules and data structures not described above.

[0049] In some embodiments, a device 200 for adjusting a standing insulin regimen 206 for a subject is a smart phone (e.g., an iPhone), laptop, tablet computer, desktop computer, or other form of electronic device (e.g., a gaming console). In some embodiments, the device 200 is not mobile. In some embodiments, the device 200 is mobile.

[0050] Figure 3 provides a further description of a device 200 that can be used with the instant disclosure. The device 200 illustrated in Figure 3 has one or more processing units (CPU's) 274, peripherals interface 370, memory controller 368, a network or other communications interface 284, a memory 192 (e.g., random access memory), a user interface 278, the user interface 278 including a display 282 and input 280 (e.g., keyboard, keypad, touch screen), an optional accelerometer 317, an optional GPS 319, optional audio circuitry 372, an optional speaker 360, an optional microphone 362, one or more optional intensity sensors 364 for detecting intensity of contacts on the device 200 (e.g., a touch-sensitive surface such as a touch-sensitive display system 282 of the device 200), an optional input/output (I/O) subsystem 366, one or more optional optical sensors 372, one or more communication buses 212 for interconnecting the aforementioned components, and a power system 276 for powering the aforementioned components.

[0051] In some embodiments, the input 280 is a touch-sensitive display, such as a touch-sensitive surface. In some embodiments, the user interface 278 includes one or more soft keyboard embodiments. The soft keyboard embodiments may include standard (QWERTY) and/or non-standard configurations of symbols on the displayed icons.

[0052] The device 200 illustrated in Figure 3 optionally includes, in addition to accelerometer(s) 317, a magnetometer (not shown) and a GPS 319 (or GLONASS or other global navigation system) receiver for obtaining information concerning the location and orientation (e.g., portrait or landscape) of the device 200 and/or for determining an amount of physical exertion by the subject.

[0053] It should be appreciated that the device 200 illustrated in Figure 3 is only one example of a multifunction

device that may be used for adjusting a standing insulin regimen 206 for a subject, and that the device 200 optionally has more or fewer components than shown, optionally combines two or more components, or optionally has a different configuration or arrangement of the components. The various components shown in Figure 3 are implemented in hardware, software, firmware, or a combination thereof, including one or more signal processing and/or application specific integrated circuits.

[0054] Memory 192 of the device 200 illustrated in Figure 3 optionally includes high-speed random access memory and optionally also includes non-volatile memory, such as one or more magnetic disk storage devices, flash memory devices, or other non-volatile solid-state memory devices. Access to memory 192 by other components of the device 200, such as CPU(s) 274 is, optionally, controlled by the memory controller 368.

[0055] The peripherals interface 370 can be used to couple input and output peripherals of the device to CPU(s) 274 and memory 192. The one or more processors 274 run or execute various software programs and/or sets of instructions stored in memory 192, such as the insulin regimen adjustment module 204, to perform various functions for the device 200 and to process data.

[0056] In some embodiments, the peripherals interface 370, CPU(s) 274, and memory controller 368 are, optionally, implemented on a single chip. In some other embodiments, they are, optionally, implemented on separate chips.

[0057] RF (radio frequency) circuitry of network interface 284 receives and sends RF signals, also called electromagnetic signals. In some embodiments, the plurality of glucose measurements 222 are received using this RF circuitry from a glucose sensor 102 associated with a subject. In some embodiments insulin medicament records 230 are received using this RF circuitry from one or more insulin pens 104 that subject uses to inject insulin medicaments. In some embodiments, RF circuitry 108 converts electrical signals to/from electromagnetic signals and communicates with communications networks and other communications devices, glucose sensors 102, and insulin pens 104 via the electromagnetic signals. RF circuitry 284 optionally includes well-known circuitry for performing these functions, including but not limited to an antenna system, an RF transceiver, one or more amplifiers, a tuner, one or more oscillators, a digital signal processor, a CODEC chipset, a subscriber identity module (SIM) card, memory, and so forth. RF circuitry 284 optionally communicates with the communication network 106. In some embodiments, the circuitry 284 does not include RF circuitry and, in fact, is connected to the network 106 through one or more hard wires (e.g., an optical cable, a coaxial cable, or the like).

[0058] In some embodiments, audio circuitry 372, optional speaker 360, and optional microphone 362 provide an audio interface between the subject and the device 200. The audio circuitry 372 receives audio data from peripherals interface 370, converts the audio data to elec-

trical signals, and transmits the electrical signals to speaker 360. Speaker 360 converts the electrical signals to human-audible sound waves. Audio circuitry 372 also receives electrical signals converted by the microphone 362 from sound waves. Audio circuitry 372 converts the electrical signal to audio data and transmits the audio data to peripherals interface 370 for processing. Audio data is, optionally, retrieved from and/or transmitted to memory 192 and/or RF circuitry 284 by peripherals interface 370.

[0059] In some embodiments, the power supply 276 optionally includes a power management system, one or more power sources (e.g., battery, alternating current (AC)), a recharging system, a power failure detection circuit, a power converter or inverter, a power status indicator (e.g., a light-emitting diode (LED)) and any other components associated with the generation, management and distribution of power in portable devices.

[0060] In some embodiments, the device 200 optionally also includes one or more optical sensors 372. The optical sensor(s) 372 optionally include charge-coupled device (CCD) or complementary metal-oxide semiconductor (CMOS) phototransistors. The optical sensor(s) 372 receive light from the environment, projected through one or more lens, and converts the light to data representing an image. The optical sensor(s) 372 optionally capture still images and/or video. In some embodiments, an optical sensor is located on the back of device 200, opposite the display 282 on the front of the device, so that the input 280 is enabled for use as a viewfinder for still and/or video image acquisition. In some embodiments, another optical sensor 372 is located on the front of the device 200 so that the subject's image is obtained (e.g., to verify the health or condition of the subject, to determine the physical activity level of the subject, or to help diagnose a subject's condition remotely, etc.).

[0061] As illustrated in Figure 3, a device 200 preferably comprises an operating system 202 that includes procedures for handling various basic system services. Operating system 202 (e.g., iOS, DARWIN, RTXC, LINUX, UNIX, OS X, WINDOWS, or an embedded operating system such as VxWorks) includes various software components and/or drivers for controlling and managing general system tasks (e.g., memory management, storage device control, power management, etc.) and facilitates communication between various hardware and software components.

[0062] In some embodiments a device 200 is a smart phone. In other embodiments, a device 200 is not a smart phone but rather is a tablet computer, desktop computer, emergency vehicle computer, or other form or wired or wireless networked device. In some embodiments, the device 200 has any or all of the circuitry, hardware components, and software components found in the device 200 depicted in Figures 2 or 3. In the interest of brevity and clarity, only a few of the possible components of the device 200 are shown in order to better emphasize the additional software modules that are installed on the de-

vice 200.

[0063] While the system 48 disclosed in Figure 1 can work standalone, in some embodiments it can also be linked with electronic medical records to exchange information in any way.

[0064] Now that details of a system 48 for adjusting a standing insulin regimen (206) for a subject has been disclosed, details regarding a flow chart of processes and features of the system, in accordance with an embodiment of the present disclosure, are disclosed with reference to Figures 4A through 4D. In some embodiments, such processes and features of the system are carried out by the insulin regimen adjustment module 204 illustrated in Figures 2 and 3.

[0065] *Block 402.* The goal of insulin therapy in subjects with either type 1 diabetes mellitus or type 2 diabetes mellitus is to match as closely as possible normal physiologic insulin secretion to control fasting and post-prandial plasma glucose. This is done with a standing insulin regimen 206 for the subject. One aspect of the present disclosure provides a device 200 for adjusting the standing insulin regimen. In the present disclosure, the standing insulin regimen comprises a basal insulin medicament dosage regimen 208. The device comprises one or more processors 274 and a memory 192/290. The memory stores instructions that, when executed by the one or more processors, perform a method. In the method, a first data set 220 is obtained.

[0066] The first data set comprises a plurality of autonomous glucose measurements of the subject from a glucose sensor 102. Each respective autonomous glucose measurement 222 in the plurality of autonomous glucose measurements includes a timestamp 224 representing when the respective measurement was made. The first data set may be in any format, and in fact may be spread across multiple files or data structures, provided that such files or data structures are addressable by the insulin regimen adjustment module 204 or equivalent process.

[0067] The FREESTYLE LIBRE CGM by ABBOTT ("LIBRE") is an example of a glucose sensor that may be used as a glucose sensor 102. The LIBRE allows calibration-free glucose measurements with an on-skin coin-sized sensor, which can send up to eight hours of data to a reader device (e.g., the device 200) via near field communications, when brought close together. The LIBRE can be worn for fourteen days in all daily life activities. Referring to block 404, in some embodiments, successive measurements in the plurality of autonomous glucose measurements are taken from the subject at an interval rate of 5 minutes or less, 3 minutes or less, or 1 minute or less.

[0068] *Block 406.* Referring to block 406 of Figure 4A, in addition to the autonomous glucose measurements of the first data set 220, a second data set 228 is obtained from one or more insulin pens 104 used by the subject to apply the standing insulin regimen. The second data set may be in any format, and in fact may be spread across multiple files or data structures, provided that such

files or data structures are addressable by the insulin regimen adjustment module 204 or equivalent process. As such, the instant disclosure leverages the recent advances of insulin administration pens, which have become "smart" in the sense that they can remember the timing and the amount of insulin administered in the past. One example of such an insulin pen 104 is the NovoPen 5. Such pens assists patients in logging doses and prevent double dosing. It is contemplated that insulin pens will be able to send and receive insulin medicament dose volume and timing, thus allowing the integration of continuous glucose monitors 102, insulin pens 104 and the algorithms of the present disclosure. As such, the second data set comprises a plurality of insulin medicament records from one or more insulin pens 104. In some embodiments, these data sets are wireless communicated to the device 200 from the one or more insulin pens 104.

[0069] Each insulin medicament record 230 in the plurality of medicament records comprises: (i) a respective insulin medicament injection event 232 including an amount of insulin medicament injected 234 into the subject using a respective insulin pen in the one or more insulin pens and (ii) a corresponding electronic timestamp 238 that is automatically generated by the respective insulin pen 104 upon occurrence of the respective insulin medicament injection event. In some embodiments, additional data is found in the insulin medicament records, such as drug lot number.

[0070] Referring to block 408, in some embodiments the device 200 further comprises a wireless receiver (284). In such embodiments, the first data set is obtained wirelessly from a glucose sensor (102) affixed to the subject and/or the second data set is obtained wirelessly from the one or more insulin pens using the wireless receiver. Referring to block 410, the method continues by identifying a plurality of fasting events using the plurality of autonomous glucose measurements of the subject and the respective timestamps in the first data set. Glucose measurements during fasting events are of importance for measuring basal glucose levels. Such basal glucose levels provide insight on whether the basal insulin medicament dosage in a basal insulin medicament dosage regimen is appropriate. Glucose measurements temporally outside of fasting events are more difficult to interpret because they are confounded by the ingestion of meals, which affects glucose levels.

[0071] There are a number of methods for detecting a fasting event using autonomous glucose measurements from a glucose monitor 102. For instance, referring to block 412, in some embodiments a first fasting event (in the plurality of fasting events) is identified in a first time period (e.g., a period of 24 hours) encompassed by the plurality of autonomous glucose measurements by first

computing a moving period of variance σ_k^2 across the plurality of autonomous glucose measurements, where:

$$\sigma_k^2 = \left(\frac{1}{M} \sum_{i=k-M}^k (G_i - \bar{G}) \right)^2$$

and where, G_i is the i^{th} glucose measurement in the portion k of the plurality of glucose measurements, M is a number of glucose measurements in the plurality of glucose measurements and represents a contiguous predetermined time span, \bar{G} is the mean of the M glucose measurements selected from the plurality of glucose measurements, and k is within the first time period. As an example, the plurality of glucose measurements may span several days or weeks, with autonomous glucose measurements taken every five minutes. A first time period (e.g., one day) k within this overall time span is selected and thus the portion k of the plurality of measurements is examined for a period of minimum variance. The first fasting period is deemed to be the period of

minimum variance $\min_k \sigma_k^2$ within the first time period. Next, the process is repeated with portion k of the plurality of glucose measurements by examining the next portion k of the plurality of glucose measurements for another period of minimum variance thereby assigning another fasting period. Repetition of this method through all portions k of the plurality of glucose measurements is used to build the plurality of fasting periods.

[0072] *Block 414.* Referring to block 414 of Fig. 4B, the method continues by applying a first characterization 244 to each respective fasting event 242 in the plurality of fasting events. Figure 3 illustrates. For each respective fasting event 242 in the plurality of fasting events there is a first characterization 244 for the respective fasting event. The first characterization 244 is one of basal regimen adherent and basal regimen nonadherent.

[0073] A respective fasting event is deemed basal regimen adherent when the second data set includes one or more medicament records that establish, on a temporal and quantitative basis, adherence with the standing basal insulin medicament dosage regimen during the respective fasting event. A respective fasting event is deemed basal regimen nonadherent when the second data set fails to include one or more medicament records that establish, on a temporal and quantitative basis, adherence with the standing basal insulin medicament dosage regimen during the respective fasting event.

[0074] Referring to block 416, in some embodiments the basal regimen specifies that a basal dose of long acting insulin medicament (210) is to be taken during each respective epoch (212) in a plurality of epochs and that a respective fasting event is deemed basal regimen nonadherent when there are no medicament records in the second data set for the epoch associated with the respective fasting event. In various embodiments, each epoch in the plurality of epochs is two days or less, one day or less, or 12 hours or less (418). Thus, referring to

Figure 9, consider the case where the first data set 220 is used to identify a fasting period 902 and the standing basal insulin medicament dosage regimen specifies to take dosage A of a long acting insulin medicament every 24 hours. In this example, therefore, the epoch is one day (24 hours). The fasting event 242 is inherently timestamped because it is derived from a period of minimum variance in timestamped glucose measurements, or by other forms of analysis of the timestamped autonomous glucose measurements. Thus the timestamp, or period of fasting, represented by a respective fasting event is used as a starting point for examining whether the fasting event is basal regimen adherent 904. For instance, if the period of fasting associated with the respective timestamp is 6:00 AM on Tuesday, May 17, what is sought in the second data set 228 is evidence that the subject took dosage A of the long acting insulin medicament in the 24 hour period (the epoch) leading up to 6:00 AM on Tuesday, May 17 (and not more or less of the prescribed dosage). If the subject took the prescribed dosage of the long acting insulin medicament during this epoch, the respective fasting event (and/or the basal injection event and/or the glucose measurements during this time) is deemed basal regimen adherent 906 (of Figure 9), and Figure 10, left panel. If the subject did not take the prescribed dosage of the long acting insulin medicament during this epoch (or took more than the prescribed dosage of the long acting insulin medicament during this period), the respective fasting event (and/or the basal injection event and/or the glucose measurements during this time) is deemed basal regimen nonadherent 908 (of Figure 9), and Figure 10, right panel.

[0075] Figure 11 illustrates how basal adherence may be plotted as a function of time, showing which basal events are deemed missing, for instance, because certain fasting event were deemed basal regimen nonadherent.

[0076] In some embodiments a fasting event is not detected during an epoch when, in fact, the basal insulin medicament regimen specifies that a basal insulin injection event must occur. Thus, the basal injection should be taken according to the prescribed regimen. According to the example above, this epoch would not have a basal adherence categorization for failure to find a fasting event. In some such embodiments, because the basal insulin medicament regimen is known, a determination as to the adherence (of the glucose measurement during the epoch in question and/or the basal injection event in the epoch) based on the basal insulin medicament regimen itself and the injection event data (second data set), and thus does not require detecting the fasting period from the glucose sensor data. As another example, if the basal insulin medicament regimen is once weekly basal injection, the exemplary procedure would look for a basal injection within a seven day window even if a fasting event is not found.

[0077] *Block 420.* Referring to block 420 of Figure 4B, the method continues by adjusting amounts of insulin

medicament dosage in the basal insulin medicament dosage regimen for the subject based upon glucose measurements in the first data set that are contemporaneous with the fasting events that are deemed basal regimen adherent and by excluding glucose measurements in the first data set that are contemporaneous with fasting events that are deemed basal regimen nonadherent. Conventional methods for such adjusting may be used, and in fact may be somewhat subjectively based on the health care practitioner's intuition, past experience with a subject, absence or presence of risk factors or other metrics. The innovation here is that data that is used to adjust the insulin medicament dosage in the basal insulin medicament dosage regimen, basal glucose measurements, is obtained without reliance on the subject's manual records. Autonomous glucose records are used to automatically identify fasting events, and only the glucose measurements in the epic associated with fasting event that are deemed basal regimen nonadherent (because the proper basal insulin medicament dosage was taken during the epic) are relied upon to establish basal glucose levels in the subject over time. Glucose measurements in epochs having fasting events that are deemed basal regimen nonadherent are not used.

[0078] Referring to block 422 of Figure 4C, in some embodiments the standing insulin regimen further comprises a bolus insulin medicament dosage regimen 214 in addition to the basal insulin medicament dosage regimen. In some such embodiments, each respective insulin medicament injection event 232 in the plurality of medicament records further indicates a respective type of insulin medicament 236 injected into the subject from one of (i) a long acting insulin medicament and (ii) a short acting insulin medicament. Typically, the long acting insulin medicament is for the basal insulin medicament dosage regimen 208 whereas the short acting insulin medicament is for the bolus insulin medicament dosage regimen 214.

[0079] Advantageously, the instant disclosure can also make use of the bolus insulin medicament injection events, when such events are present in the second data set, to provide additional information on the glucose status of the subject. Use of the bolus injection events is particularly helpful because they often occur more frequently than then basal injection events, and thus the bolus injection events often can be used to identify hyperglycaemic or hypoglycaemic events more rapidly than analysis of basal glucose data.

[0080] Referring to Figure 6, in some such embodiments, the bolus insulin medicament injection events in the first data set 220 are made use of in the following way. A plurality of meal events 246 are identified using the plurality of autonomous glucose measurements and the corresponding timestamps in the first data set using a meal detection algorithm (602-604). If no meal is detected, the process ends. If a meal is detected then a second characterization 250 is applied to each respective meal event 248 in the plurality of meal events 606. Figure

3 illustrates the data structure. The plurality of meal events 246 includes a second characterization 250 for each respective meal event 248. The second characterization is one of bolus regimen adherent and bolus regimen nonadherent.

[0081] Referring back to Figure 6, a respective meal is deemed bolus regimen adherent when one or more medicament records in the plurality of medicament records in the second data set 228 indicates, on a temporal basis, a quantitative basis and a type of insulin medicament basis, adherence with the standing bolus insulin medicament dosage regimen during the respective meal 608. A respective meal is deemed bolus regimen nonadherent when the plurality of medicament records fails to indicate adherence, on a temporal basis, a quantitative basis, and a type of insulin medicament basis, with the standing bolus insulin medicament dosage regimen during the respective meal 608. For instance, consider the case where the standing bolus insulin medicament dosage regimen specifies that dosage A of insulin medicament B is to be taken up 30 minutes before a respective meal and that a certain meal that occurred at 7:00 AM on Tuesday, May 17. It will be appreciated that dosage A may be a function of the anticipated size or type of meal. What is sought in the second data set 228 is evidence that the subject took dosage A of insulin medicament B in the 30 minutes leading up to 7:00 AM on Tuesday, May 17 (and not more or less of the prescribed dosage). If the subject took the prescribed dosage A of the insulin medicament B during the 30 minutes leading up to the respective meal, the respective meal (and/or the bolus administration(s) and/or the glucose measurements during this time) is deemed bolus regimen adherent 608 (of Figure 6) and Figure 7 left panel. If the subject did not take the prescribed dosage A of the insulin medicament B during the 30 minutes leading up to the respective meal (or took more than the prescribed dosage A of the insulin medicament B during this period), the respective meal (and/or the bolus administration and/or the glucose measurements during this time) is deemed bolus regimen nonadherent 610 (of Figure 6) and Figure 7 right panel. The time period of 30 minutes here is exemplary, in other embodiments the time is shorter or longer (e.g., between 15 minutes to 2 hours prior to the meal and/or is dependent upon the type of insulin medicament prescribed). In other cases the standing bolus insulin medicament dosage regimen specifies that a dosage of insulin is to be taken in a time period following the meal, e.g., 30 minutes or less, 15 minutes or less, 5 minutes or less. In other cases the standing bolus insulin medicament dosage regimen specifies that a dosage of insulin is to be taken in a first predetermined time period before the meal, (e.g., 30 minutes or less, 15 minutes or less, 5 minutes or less), and/or a second predetermined time period after the meal (e.g., 30 minutes or less, 15 minutes or less, 5 minutes or less), where the first predetermined time period is the same or different than the second predetermined time period. Figure 8 illustrates how bolus

adherence may be plotted as a function of time, showing which bolus events are deemed missing, for instance, because certain meals were deemed bolus regimen non-adherent.

[0082] In some embodiments, no bolus for a particular meal is required by the bolus insulin medicament dosage regimen and thus that meal is adherent even though there was no bolus prior to the meal. For instance, some bolus regimens only assume a bolus for dinner and not for breakfast and lunch. Therefore a detected lunch meal event but no corresponding bolus would be classified as in adherence.

[0083] Further, insulin medicament dosage in the bolus insulin medicament dosage regimen for the subject is adjusted by using glucose measurements in the first data set that are temporally associated with meal events that are deemed bolus adherent and by excluding glucose measurements in the first data set that are temporally associated with meal events that are deemed bolus nonadherent. Conventional methods for such adjusting may be used, and in fact may be somewhat subjectively based on the health care practitioner's intuition, past experience with a subject, absence or presence of risk factors or other metrics. The innovation here is that data that is used to adjust the insulin medicament dosage in the bolus insulin medicament dosage regimen, glucose measurements that are temporally associated with meal events that are deemed bolus adherent, is obtained without reliance on the subject's manual records. Autonomous glucose records are used to automatically identify meal events, and only the glucose measurements that are temporally associated with meal events that are deemed bolus adherent (because the proper bolus insulin medicament dosage was taken prior to meal) are relied upon to establish bolus glucose levels in the subject. Glucose measurements associated with meals that are deemed bolus nonadherent are not used. Moreover, Figure 8 illustrates how the bolus regimen adherence data can be quantified and visualized.

[0084] Referring to block 424, in some embodiments the first data set further comprises a plurality of feed-forward events. In some embodiments, each respective feed-forward event 226 in the plurality of feed-forward events represents an instance where the subject has indicated they are having or are about to have a meal. In such embodiments, the plurality of meal events are verified against the plurality of feed-forward events deduced by way of block 422 by either removing any respective meal event in the plurality of meal events that fails to temporally match any feed-forward event in the plurality of feed-forward events. In other embodiments, feed-forward events are caloric burn rate of the subject, walking events of the subject, exercise events of the subject, and/or sleep events of the subject, some of which may be detected using the optional GPS 319, accelerometers 317 or magnetometers of the device 200.

[0085] Referring to block 426 of Figure 4D, in some embodiments, the bolus insulin medicament dosage reg-

imen specifies that the short acting insulin medicament is to be taken up to a predetermined amount of time prior to or after a meal. A respective meal is deemed bolus regimen nonadherent when there is no insulin medicament record of the short acting insulin medicament type having an electronic timestamp up to the predetermined amount of time prior to or after the respective meal. In some such embodiments, the predetermined amount of time is thirty minutes or less, twenty minutes or less, or fifteen minutes or less (428).

[0086] Referring to block 430 of Figure 4D, in some embodiments, the long acting insulin medicament consists of a single insulin medicament having a duration of action that is between 12 and 24 hours or a mixture of insulin medicaments that collectively have a duration of action that is between 12 and 24 hours. Examples of such long acting insulin medicaments include, but are not limited to Insulin Degludec (developed by Novo Nordisk under the brand name Tresiba), NPH (Schmid, 2007, "New options in insulin therapy. *J Pediatrics* (Rio J). 83(Suppl 5):S146-S155), Glargine (LANTUS, March 2, 2007, insulin glargine [rDNA origin] injection, [prescribing information], Bridgewater, New Jersey: Sanofi-Aventis), and Determir (Plank et al., 2005, "A double-blind, randomized, dose-response study investigating the pharmacodynamic and pharmacokinetic properties of the long-acting insulin analog detemir," *Diabetes Care* 28:1107-1112). The short acting insulin medicament consists of a single insulin medicament having a duration of action that is between three to eight hours or a mixture of insulin medicaments that collectively have a duration of action that is between three to eight hours. Examples of such short acting insulin medicaments include, but are not limited, to Lispro (HUMALOG, May 18, 2001, insulin lispro [rDNA origin] injection, [prescribing information], Indianapolis, Indiana: Eli Lilly and Company), Aspart (NOVOLOG, July 2011, insulin aspart [rDNA origin] injection, [prescribing information], Princeton, New Jersey, Novo Nordisk Inc., July, 2011), Glulisine (Helms Kelley, 2009, "Insulin glulisine: an evaluation of its pharmacodynamic properties and clinical application," *Ann Pharmacother* 43:658-668), and Regular (Gerich, 2002, "Novel insulins: expanding options in diabetes management," *Am J Med.* 113:308-316).

[0087] Referring to block 432 of Figure 4D, in some embodiments, the identification of the plurality of meal events is performed by computing: (i) a first model comprising a backward difference estimate of glucose rate of change using the plurality of autonomous glucose measurements, (ii) a second model comprising a backward difference estimate of glucose rate of change based on Kalman filtered estimates of glucose using the plurality of autonomous glucose measurements, (iii) a third model comprising a Kalman filtered estimate of glucose and Kalman filtered estimate of rate of change (ROC) of glucose based on the plurality of autonomous glucose measurements, and/or (iv) a fourth model comprising a Kalman filtered estimate of rate of change of ROC of glucose

based on the plurality of autonomous glucose measurements. In some such embodiments, the first model, the second model, the third model and the fourth model are each computed across the plurality of autonomous glucose measurements and each respective meal event in the plurality of meal events is identified at an instance where at least three of the four models indicate a meal event (434). For further disclosure on such meal event detection, see Dassau et al., 2008, "Detection of a Meal Using Continuous Glucose Monitoring," *Diabetes Care* 31, pp. 295-300. See also, Cameron et al., 2009, "Probabilistic Evolving Meal Detection and Estimation of Meal Total Glucose Appearance," *Journal of Diabetes Science and Technology* 3(5), pp. 1022-1030. *Block 436*. Referring to block 436 of Figure 4D, in some embodiments the method illustrated in Figures 4A through 4D is repeated on an ongoing basis over time. In this way, it is possible to adjust the standing insulin regimen 206 for a subject on an ongoing basis. Thus, Figure 12 illustrates the simulation of autonomous glucose data where no knowledge on insulin injection data is available. By contrast, Figure 13 illustrates the simulation of autonomous glucose data and bolus insulin medicament injections where insulin injection data is available and periods of nonadherence with respect to a bolus injection are marked in accordance with some embodiments. In this way, it can be seen that spikes in glucose level are related to regimen non-adherence, rather than failure of the dosing regimen to stabilize glucose levels in the subject.

ALTERNATIVE EMBODIMENTS

[0088] The present invention can be implemented as a computer program product that comprises a computer program mechanism embedded in a nontransitory computer readable storage medium. For instance, the computer program product could contain the program modules shown in any combination of Figures 1, 2, or 3 and/or described in Figure 4. These program modules can be stored on a CD-ROM, DVD, magnetic disk storage product, or any other non-transitory computer readable data or program storage product.

[0089] The specific embodiments described herein are offered by way of example only. The embodiments were chosen and described in order to best explain the principles of the invention and its practical applications, to thereby enable others skilled in the art to best utilize the invention and various embodiments with various modifications as are suited to the particular use contemplated. The invention is to be limited only by the terms of the appended claims.

Claims

1. A device (200) for adjusting a standing insulin regimen (206) for a subject, the standing insulin regimen comprising a basal insulin medicament dosage reg-

imen (208), wherein the device comprises one or more processors (274) and a memory (192/290), the memory storing instructions that, when executed by the one or more processors, perform a method of:

obtaining a first data set (220), the first data set comprising a plurality of autonomous glucose measurements of the subject and, for each respective autonomous glucose measurement (222) in the plurality of autonomous glucose measurements, a timestamp (224) representing when the respective measurement was made; obtaining a second data set (228) from one or more insulin pens used by the subject to apply the standing insulin regimen, the second data set comprising a plurality of insulin medicament records, each insulin medicament record (230) in the plurality of medicament records comprising: (i) a respective insulin medicament injection event (232) including an amount of insulin medicament injected (234) into the subject using a respective insulin pen in the one or more insulin pens and (ii) a corresponding electronic timestamp (238) that is automatically generated by the respective insulin pen (104) upon occurrence of the respective insulin medicament injection event; identifying a plurality of fasting events (240) using the plurality of autonomous glucose measurements of the subject and the respective timestamps in the first data set; applying a first characterization (244) to each respective fasting event (242) in the plurality of fasting events, wherein

the first characterization is one of basal regimen adherent and basal regimen nonadherent, a respective fasting event is deemed basal regimen adherent when the second data set includes one or more medicament records that establish, on a temporal and quantitative basis, adherence with the standing basal insulin medicament dosage regimen during the respective fasting event, and a respective fasting event is deemed basal regimen nonadherent when the second data set fails to include one or more medicament records that establish, on a temporal and quantitative basis, adherence with the standing basal insulin medicament dosage regimen during the respective fasting event; and

adjusting amounts of insulin medicament dosage in the basal insulin medicament dosage regimen for the subject based upon glucose measurements in the first data set that are contem-

5
10
15
20
25
30
35
40
45
50
55

poraneous with the fasting events that are deemed basal regimen adherent and by excluding glucose measurements in the first data set that are contemporaneous with fasting events that are deemed basal regimen nonadherent.

2. The device of claim 1, wherein

the standing insulin regimen further comprises a bolus insulin medicament dosage regimen (214), each respective insulin medicament injection event (232) in the plurality of medicament records further indicates a respective type of insulin medicament (236) injected into the subject from one of (i) a long acting insulin medicament and (ii) a short acting insulin medicament, and the method further comprises:

identifying a plurality of meal events (246) using the plurality of autonomous glucose measurements and the corresponding timestamps in the first data set; applying a second characterization (250) to each respective meal event (248) in the plurality of meal events, wherein the second characterization is one of bolus regimen adherent and bolus regimen non-adherent, a respective meal is deemed bolus regimen adherent when one or more medicament records in the plurality of medicament records indicates, on a temporal basis, a quantitative basis and a type of insulin medicament basis, adherence with the standing bolus insulin medicament dosage regimen during the respective meal, and a respective meal is deemed bolus regimen nonadherent when the plurality of medicament records fails to indicate adherence, on a temporal basis, a quantitative basis, and a type of insulin medicament basis, with the standing bolus insulin medicament dosage regimen during the respective meal; and

adjusting insulin medicament dosage in the standing insulin medicament regimen for the subject by using glucose measurements in the first data set that are temporally associated with meal events that are deemed bolus regimen adherent and by excluding glucose measurements in the first data set that are temporally associated with meal events that are deemed bolus regimen nonadherent.

3. The device of claim 1 or 2, the device further comprising a wireless receiver (284), and wherein the first data set is obtained wirelessly from a glucose

sensor (102) affixed to the subject and/or the second data set is obtained wirelessly from the one or more insulin pens.

5 4. The device of claim 2, wherein

the first data set further comprises a plurality of feed-forward events, each respective feed-forward event (226) in the plurality of feed-forward events represents an instance where the subject has indicated they are having or are about to have a meal, and the plurality of meal events are verified against the plurality of feed-forward events by either removing any respective meal event in the plurality of meal events that fails to temporally match any feed-forward event in the plurality of feed-forward events.

20 5. The device of any one of claims 1-4, wherein successive measurements in the plurality of autonomous glucose measurements are taken from the subject at an interval rate of 5 minutes or less, 3 minutes or less, or 1 minute or less.

25 6. The device of any one of claims 1-5, wherein the basal regimen is associated with a plurality of epochs, the basal regimen specifies that a basal dose of long acting insulin medicament (210) is to be taken during each respective epoch (212) in the plurality of epochs, and a respective fasting event is deemed basal regimen nonadherent when there are no medicament records in the second data set for the epoch associated with the respective fasting event.

30 7. The device of claim 6, wherein each epoch in the plurality of epochs is one week or less, two days or less, one day or less, or 12 hours or less.

35 8. The device of claim 2, wherein

the bolus insulin medicament dosage regimen specifies that the short acting insulin medicament is to be taken up to a predetermined amount of time prior to or after a meal, and a respective meal is deemed bolus regimen non-adherent when there is no insulin medicament record of the short acting insulin medicament type having an electronic timestamp up to the predetermined amount of time prior to or after the respective meal.

40 9. The device of claim 8, wherein the predetermined amount of time is thirty minutes or less, twenty minutes or less, or fifteen minutes or less.

45 10. The device of claim 2, wherein

the long acting insulin medicament consists of a single insulin medicament having a duration of action that is between 12 and 24 hours or a mixture of insulin medicaments that collectively have a duration of action that is between 12 and 24 hours, and
 the short acting insulin medicament consists of a single insulin medicament having a duration of action that is between three to eight hours or a mixture of insulin medicaments that collectively have a duration of action that is between three to eight hours.

11. The device of claim 2, wherein the identifying the plurality of meal events is performed by computing:

- (i) a first model comprising a backward difference estimate of glucose rate of change using the plurality of autonomous glucose measurements,
- (ii) a second model comprising a backward difference estimate of glucose rate of change based on Kalman filtered estimates of glucose using the plurality of autonomous glucose measurements,
- (iii) a third model comprising a Kalman filtered estimate of glucose and Kalman filtered estimate of rate of change (ROC) of glucose based on the plurality of autonomous glucose measurements, or
- (iv) a fourth model comprising a Kalman filtered estimate of rate of change of ROC of glucose based on the plurality of autonomous glucose measurements.

12. The device of claim 11, wherein the first model, the second model, the third model and the fourth model are each computed across the plurality of autonomous glucose measurements and each respective meal event in the plurality of meal events is identified at an instance where at least three of the four models indicates a meal event.

13. The device of any one of claims 1-12, the method further comprising repeating the method on an ongoing basis over time.

14. The device of any one of claims 1-13, wherein the identifying the plurality of fasting events comprises identifying a first fasting period in a first time period encompassed by the plurality of autonomous glucose measurements by:

computing a moving period of variance σ_k^2 across the plurality of autonomous glucose measurements, wherein:

$$\sigma_k^2 = \left(\frac{1}{M} \sum_{i=k-M}^k (G_i - \bar{G}) \right)^2$$

wherein,

G_i is the i^{th} autonomous glucose measurement in a portion k of the plurality of autonomous glucose measurements,
 M is a number of autonomous glucose measurements in the plurality of glucose measurements and represents a contiguous predetermined time span,
 \bar{G} is the mean of the autonomous glucose measurements selected from the plurality of autonomous glucose measurements, and
 k is within the first time period; and

associating the first fasting period with a period of minimum variance $\min_k \sigma_k^2$ within the first time period.

15. A computer-implemented method for adjusting a standing insulin regimen for a subject, the standing insulin regimen comprising a basal insulin medication dosage regimen, the method comprising:

- obtaining a first data set, the first data set comprising a plurality of autonomous glucose measurements of the subject and, for each respective autonomous glucose measurement in the plurality of autonomous glucose measurements, a timestamp representing when the respective measurement was made;
- obtaining a second data set from one or more insulin pens used by the subject to apply the standing insulin regimen, the second data set comprising a plurality of insulin medicament records, each insulin medicament record in the plurality of medicament records comprising: (i) a respective insulin medicament injection event including an amount of insulin medicament injected into the subject using a respective insulin pen in the one or more insulin pens and (ii) a corresponding electronic timestamp that is automatically generated by the respective insulin pen upon occurrence of the respective insulin medicament injection event;
- identifying a plurality of fasting events using the plurality of autonomous glucose measurements of the subject and the respective timestamps in the first data set;
- applying a first characterization to each respective fasting event in the plurality of fasting

events, wherein

the first characterization is one of basal regimen adherent and basal regimen nonadherent,

a respective fasting event is deemed basal regimen adherent when the second data set includes one or more medicament records that establish, on a temporal and quantitative basis, adherence with the standing basal insulin medicament dosage regimen during the respective fasting event, and a respective fasting event is deemed basal regimen nonadherent when the second data set fails to include one or more medicament records that establish, on a temporal and quantitative basis, adherence with the standing basal insulin medicament dosage regimen during the respective fasting event; and

adjusting insulin medicament dosage in the basal insulin medicament dosage regimen for the subject based upon glucose measurements in the first data set that are contemporaneous with the fasting events that are deemed basal regimen adherent and by excluding glucose measurements in the first data set that are contemporaneous with fasting events that are deemed basal regimen nonadherent.

Patentansprüche

1. Vorrichtung (200) zum Anpassen eines ständigen Insulinschemas (206) für eine Person, wobei das ständige Insulinschema ein Basalinsulinmedikamentendosierungsschema (208) umfasst, wobei die Vorrichtung einen oder mehrere Prozessoren (274) und einen Speicher (192/290) umfasst und in dem Speicher Befehle gespeichert sind, die bei Ausführung von dem einen oder den mehreren Prozessoren ein Verfahren ausführen von:

Erlangen eines ersten Datensatzes (220), wobei der erste Datensatz mehrere autonome Glukosemessungen der Person und für jede entsprechende autonome Glukosemessung (222) in den mehreren autonomen Glukosemessungen einen Zeitstempel (224) umfasst, der angibt, wann die entsprechende Messung durchgeführt wurde;

Erlangen eines zweiten Datensatzes (228) von einem oder mehreren Insulin-Pens, die von der Person zur Anwendung des ständigen Insulinschemas verwendet werden, wobei der zweite Datensatz mehrere Insulinmedikamentendatsätze umfasst und jeder Insulinmedikamen-

tendatsatz (230) in den mehreren Medikamentendatsätzen umfasst: (i) ein entsprechendes Insulinmedikamenteninjektionsereignis (232), das eine Menge an Insulinmedikament umfasst, die unter Verwendung eines entsprechenden Insulin-Pens von dem einen oder den mehreren Insulin-Pens in die Person injiziert wird (234), und (ii) einen entsprechenden elektronischen Zeitstempel (238), der durch den entsprechenden Insulin-Pen (104) beim Auftreten des entsprechenden Insulinmedikamenteninjektionsereignisses automatisch erzeugt wird;

Identifizieren von mehreren Fastenereignissen (240) unter Verwendung der mehreren autonomen Glukosemessungen der Person und der entsprechenden Zeitstempel in dem ersten Datensatz;

Anwenden einer ersten Charakterisierung (244) auf jedes entsprechende Fastenereignis (242) in den mehreren Fastenereignissen, wobei

die erste Charakterisierung eine Charakterisierung von das Basalschema einhaltend und das Basalschema nicht einhaltend ist, ein entsprechendes Fastenereignis als das Basalschema einhaltend angesehen wird, wenn der zweite Datensatz einen oder mehrere Medikamentendatsätze umfasst, die auf zeitlicher und quantitativer Basis die Einhaltung des ständigen Basalinsulinmedikamentendosierungsschemas während des entsprechenden Fastenereignisses nachweisen, und

ein entsprechendes Fastenereignis als das Basalschema nicht einhaltend angesehen wird, wenn der zweite Datensatz nicht einen oder mehrere Medikamentendatsätze enthält, die auf zeitlicher und quantitativer Basis die Einhaltung des ständigen Basalinsulinmedikamentendosierungsschemas während des entsprechenden Fastenereignisses nachweisen; und

Anpassen der Mengen an Insulinmedikamentendosierung in dem Basalinsulinmedikamentendosierungsschema für die Person basierend auf Glukosemessungen in dem ersten Datensatz, die gleichzeitig mit den Fastenereignissen erfolgen, die als das Basalschema einhaltend angesehen werden, und durch Ausschließen von Glukosemessungen in dem ersten Datensatz, die gleichzeitig mit Fastenereignissen erfolgen, die als das Basalschema nicht einhaltend angesehen werden.

2. Vorrichtung nach Anspruch 1, wobei

das ständige Insulinschema ferner ein Bolusinsulinmedikamentendosierungsschema (214) umfasst, jedes entsprechende Insulinmedikamentinjektionsereignis (232) in den mehreren Medikamentendatensätzen ferner einen entsprechenden Typ von in die Person injizierten Insulinmedikamenten (236) von einem von (i) einem langwirkenden Insulinmedikament und (ii) einem kurzwirkenden Insulinmedikament anzeigt, und wobei das Verfahren ferner umfasst:

Identifizieren von mehreren Mahlzeitergebnissen (246) unter Verwendung der mehreren autonomen Glukosemessungen und der entsprechenden Zeitstempel in dem ersten Datensatz;

Anwenden einer zweiten Charakterisierung (250) auf jedes entsprechende Mahlzeitergebnis (248) in den mehreren Mahlzeitergebnissen, wobei

die zweite Charakterisierung eine von Bolusschema einhaltend und Bolusschema nicht einhaltend ist,

eine entsprechende Mahlzeit als das Bolusschema einhaltend angesehen wird, wenn ein oder mehrere Medikamentendatensätze in den mehreren Medikamentendatensätzen auf zeitlicher Basis, auf quantitativer Basis und auf Basis des Typs des Insulinmedikaments die Einhaltung des ständigen Bolusinsulinmedikamentendosierungsschemas während der entsprechenden Mahlzeit anzeigen, und

eine entsprechende Mahlzeit als das Bolusschema nicht einhaltend angesehen wird, wenn die mehreren Medikamentendatensätze auf zeitlicher Basis, auf quantitativer Basis und auf Basis des Typs des Insulinmedikaments die Einhaltung des ständigen Bolusinsulinmedikamentendosierungsschemas während der entsprechenden Mahlzeit nicht anzeigen; und

Anpassen der Insulinmedikamentendosierung in dem ständigen Insulinmedikamentenschema für die Person durch Verwendung von Glukosemessungen in dem ersten Datensatz, die zeitlich mit Mahlzeitergebnissen verbunden sind, die als das Bolusschema einhaltend angesehen werden, und durch Ausschließen von Glukosemessungen in dem ersten Datensatz, die zeitlich mit Mahlzeitergebnissen verbunden sind, die als das Bolusschema nicht einhaltend angesehen werden.

3. Vorrichtung nach Anspruch 1 oder 2, wobei die Vorrichtung ferner einen drahtlosen Empfänger (284)

umfasst, und wobei der erste Datensatz drahtlos von einem an der Person befestigten Glukosesensor (102) und/oder der zweite Datensatz drahtlos von dem einen oder den mehreren Insulin-Pens erlangt wird.

4. Vorrichtung nach Anspruch 2, wobei

der erste Datensatz ferner mehrere Vorwärtskopplungsereignisse umfasst, jedes entsprechende Vorwärtskopplungsereignis (226) von den mehreren Vorwärtskopplungsereignissen einen Fall repräsentiert, in dem die Person angezeigt hat, dass sie eine Mahlzeit einnimmt oder im Begriff ist, eine Mahlzeit einzunehmen, und die mehreren Mahlzeitergebnisse gegenüber den mehreren Vorwärtskopplungsereignissen verifiziert werden, indem entweder irgendein entsprechendes Mahlzeitergebnis in den mehreren Mahlzeitergebnissen entfernt wird, das zeitlich nicht mit irgendeinem Vorwärtskopplungsereignis von den mehreren Vorwärtskopplungsereignissen übereinstimmt.

5. Vorrichtung nach einem der Ansprüche 1 bis 4, wobei aufeinanderfolgende Messungen in den mehreren autonomen Glukosemessungen von der Person mit einer Intervallrate von 5 Minuten oder weniger, 3 Minuten oder weniger oder 1 Minute oder weniger durchgeführt werden.

6. Vorrichtung nach einem der Ansprüche 1 bis 5, wobei das Basalschema mit mehreren Epochen verbunden ist und das Basalschema spezifiziert, dass eine Basaldosis eines lang wirkenden Insulinmedikaments (210) während jeder entsprechenden Epoche (212) von den mehreren Epochen einzunehmen ist, und ein entsprechendes Fastenereignis als das Basalschema nicht einhaltend angesehen wird, wenn es in dem zweiten Datensatz für die mit dem entsprechenden Fastenereignis verbundene Epoche keine Medikamentendatensätze gibt.

7. Vorrichtung nach Anspruch 6, wobei jede Epoche von den mehreren Epochen eine Woche oder weniger, zwei Tage oder weniger, einen Tag oder weniger oder 12 Stunden oder weniger beträgt.

8. Vorrichtung nach Anspruch 2, wobei

das Bolusinsulinmedikamentendosierungsschema bestimmt, dass das kurzwirkende Insulinmedikament bis zu einer vorbestimmten Zeitdauer vor oder nach einer Mahlzeit einzunehmen ist, und eine entsprechende Mahlzeit als das Bolus-

schema nicht einhaltend angesehen wird, wenn es keinen Insulinmedikamentendatensatz des kurzwirksamen Insulinmedikamententyps mit elektronischem Zeitstempel bis zu der vorgegebenen Zeitdauer vor oder nach der entsprechenden Mahlzeit gibt.

9. Vorrichtung nach Anspruch 8, wobei die vorbestimmte Zeitspanne dreißig Minuten oder weniger, zwanzig Minuten oder weniger oder fünfzehn Minuten oder weniger beträgt.

10. Vorrichtung nach Anspruch 2, wobei

das langwirkende Insulinmedikament aus einem einzelnen Insulinmedikament mit einer Wirkungsdauer zwischen 12 und 24 Stunden oder aus einer Mischung von Insulinmedikamenten besteht, die zusammen eine Wirkungsdauer zwischen 12 und 24 Stunden aufweisen, und das kurzwirkende Insulinmedikament aus einem einzelnen Insulinmedikament mit einer Wirkungsdauer von drei bis acht Stunden oder einer Mischung von Insulinmedikamenten besteht, die zusammen eine Wirkungsdauer von drei bis acht Stunden aufweisen.

11. Vorrichtung nach Anspruch 2, wobei die Identifizierung der mehreren Mahlzeitereignisse erfolgt mittels Berechnung von:

(i) einem ersten Modell, das eine Rückwärtsdifferenzschätzung der Glukoseänderungsrate unter Verwendung der mehreren autonomen Glukosemessungen umfasst,
 (ii) einem zweiten Modell, das eine Rückwärtsdifferenzschätzung der Glukoseänderungsrate basierend auf Kalman-Filter-Glukoseschätzungen unter Verwendung mehrerer autonomer Glukosemessungen umfasst,
 (iii) einem dritten Modell, das eine Kalman-Filter-Glukoseschätzung und eine Kalman-Filter-Schätzung der Glukose-Änderungsrate (ROC) basierend auf den mehreren autonomen Glukosemessungen umfasst, oder
 (iv) einem vierten Modell, das eine Kalman-Filter-Schätzung der Glukose-Änderungsrate ROC basierend auf den mehreren autonomen Glukosemessungen umfasst.

12. Vorrichtung nach Anspruch 11, wobei das erste Modell, das zweite Modell, das dritte Modell und das vierte Modell jeweils über die mehreren autonomen Glukosemessungen hinweg berechnet werden und jedes entsprechende Mahlzeitereignis in den mehreren Mahlzeitereignissen in einem Fall identifiziert wird, in dem mindestens drei der vier Modelle ein Mahlzeitereignis anzeigen.

13. Vorrichtung nach einem der Ansprüche 1 bis 12, wobei das Verfahren ferner die kontinuierliche Wiederholung des Verfahrens über Zeit umfasst.

14. Vorrichtung nach einem der Ansprüche 1 bis 13, wobei das Identifizieren der mehreren Fastenereignisse das Identifizieren, in einem ersten Zeitraum, in dem die mehreren autonomen Glukosemessungen beinhaltet sind, eines ersten Fastenzeitraums umfasst durch:

Berechnen eines sich ändernden Varianzzeitraums σ_k^2 über die mehreren der autonomen Glukosemessungen hinweg, wobei:

$$\sigma_k^2 = \left(\frac{1}{M} \sum_{i=k-M}^k (G_i - \bar{G}) \right)^2$$

wobei,

G_i die i^{te} autonome Glukosemessung in einem Teil k der mehreren autonomen Glukosemessungen ist,

M eine Anzahl von autonomen Glukosemessungen in den mehreren Glukosemessungen ist und eine zusammenhängende vorbestimmte Zeitspanne darstellt,

\bar{G} der Mittelwert der autonomen Glukosemessungen ist, die aus den mehreren autonomen Glukosemessungen ausgewählt sind, und

k innerhalb der ersten Zeitspanne liegt; und

Verknüpfen des ersten Fastenzeitraums mit einem Minimalvarianzzeitraum

$$\min_k \sigma_k^2$$

innerhalb des ersten Zeitraums.

15. Computerimplementiertes Verfahren zum Anpassen eines ständigen Insulinschemas für eine Person, wobei das ständige Insulinschema ein Basalinsulinmedikamentendosierungsschema umfasst und das Verfahren umfasst:

Erlangen eines ersten Datensatzes, wobei der erste Datensatz mehrere autonome Glukosemessungen der Person und für jede entsprechende autonome Glukosemessung in den mehreren autonomen Glukosemessungen einen Zeitstempel umfasst, der angibt, wann die

entsprechende Messung durchgeführt wurde; Erlangen eines zweiten Datensatzes von einem oder mehreren Insulin-Pens, die von der Person zur Anwendung des ständigen Insulinschemas verwendet werden, wobei der zweite Datensatz mehrere Insulinmedikamentendatensätze umfasst und jeder Insulinmedikamentendatensatz in den mehreren Medikamentendatensätzen umfasst: (i) ein entsprechendes Insulinmedikamenteninjektionsereignis einschließlich einer Insulinmedikamentenmenge, die der Person unter Verwendung eines entsprechenden Insulin-Pens von dem einen oder den mehreren Insulin-Pens injiziert wurde, und (ii) einen entsprechenden elektronischen Zeitstempel, der beim Auftreten des entsprechenden Insulinmedikamenteninjektionsereignisses durch den entsprechenden Insulin-Pen automatisch erzeugt wird;

Identifizieren von mehreren Fastenereignissen unter Verwendung der mehreren autonomen Glukosemessungen der Person und der entsprechenden Zeitstempel in dem ersten Datensatz;

Anwenden einer ersten Charakterisierung auf jedes entsprechende Fastenereignis in den mehreren Fastenereignissen, wobei

die erste Charakterisierung eine Charakterisierung von das Basalschema einhaltend und das Basalschema nicht einhaltend ist, ein entsprechendes Fastenereignis als das Basalschema einhaltend angesehen wird, wenn der zweite Datensatz einen oder mehrere Medikamentendatensätze umfasst, die auf zeitlicher und quantitativer Basis die Einhaltung des ständigen Basalinsulinmedikamentendosierungsschemas während des entsprechenden Fastenereignisses nachweisen, und

ein entsprechendes Fastenereignis als das Basalschema nicht einhaltend angesehen wird, wenn der zweite Datensatz nicht einen oder mehrere Medikamentendatensätze enthält, die auf zeitlicher und quantitativer Basis die Einhaltung des ständigen Basalinsulinmedikamentendosierungsschemas während des entsprechenden Fastenereignisses nachweisen; und

Anpassen der Insulinmedikamentendosierung in dem Basalinsulinmedikamentendosierungsschema für die Person basierend auf Glukosemessungen in dem ersten Datensatz, die gleichzeitig mit den Fastenereignissen erfolgen, die als das Basalschema einhaltend angesehen werden, und durch Ausschließen von Glukosemessungen in dem ersten Datensatz, die gleich-

zeitig mit Fastenereignissen erfolgen, die als das Basalschema nicht einhaltend angesehen werden.

Revendications

1. Dispositif (200) pour l'ajustement d'un traitement d'insuline permanent (206) pour un sujet, le traitement d'insuline permanent comprenant un traitement de dosage de médicament d'insuline basal (208), dans lequel le dispositif comprend un ou plusieurs processeurs (274) et une mémoire (192/290), la mémoire stockant des instructions qui, lorsqu'elles sont exécutées par le ou les processeurs, exécutent un procédé pour :

l'obtention d'un premier ensemble de données (220), le premier ensemble de données comprenant une pluralité de mesures de glycémie autonomes du sujet et, pour chaque mesure de glycémie autonome respective (222) dans la pluralité de mesures de glycémie autonomes, un horodatage (224) représentant le moment où la mesure respective a été effectuée ;

l'obtention d'un deuxième ensemble de données (228) à partir d'un ou plusieurs stylos d'insuline utilisés par le sujet pour appliquer le traitement d'insuline permanent, le deuxième ensemble de données comprenant une pluralité de dossiers de médicament d'insuline, chaque dossier de médicament d'insuline (230) dans la pluralité de dossiers de médicament comprenant : (i) un événement d'injection de médicament d'insuline respectif (232) comprenant une quantité de médicament d'insuline injectée (234) au sujet à l'aide d'un stylo à insuline respectif dans le ou les stylos à insuline et (ii) un horodatage électronique correspondant (238) qui est généré automatiquement par le stylo à insuline respectif (104) lors de l'occurrence de l'événement d'injection de médicament d'insuline respectif ;

l'identification d'une pluralité d'événements de jeûne (240) à l'aide de la pluralité de mesures de glycémie autonomes du sujet et des horodatages respectifs dans le premier ensemble de données ;

l'application d'une première caractérisation (244) à chaque événement de jeûne respectif (242) dans la pluralité d'événements de jeûne, dans lequel

la première caractérisation est l'un d'un traitement basal adhérent et d'un traitement basal non adhérent, un événement de jeûne respectif est considéré comme adhérent au traitement basal

lorsque le deuxième ensemble de données comprend un ou plusieurs dossiers de médicament qui établissent, sur une base temporelle et quantitative, l'adhésion au traitement de dosage de médicament d'insuline basal permanent durant l'événement de jeûne respectif, et
 5 un événement de jeûne respectif est considéré comme non-adhérent au traitement basal lorsque le deuxième ensemble de données échoue à comprendre un ou plusieurs dossiers de médicaments qui établissent, sur une base temporelle et quantitative, l'adhésion au traitement de dosage de médicament d'insuline basal permanent durant l'événement de jeûne respectif, et ;
 10 et

l'ajustement des quantités de dosage de médicament d'insuline dans le traitement de médicament d'insuline basal pour le sujet sur base des mesures de glycémie dans le premier ensemble de données, qui sont contemporaines avec les événements de jeûne qui sont considérés comme étant un traitement basal adhérent et par l'exclusion des mesures de glycémie dans le premier ensemble de données qui sont contemporaines avec des événements de jeûne qui sont considérés comme non adhérents au traitement basal.
 20
 25
 30

2. Dispositif selon la revendication 1, dans lequel

le traitement de médicament d'insuline permanent comprend en outre un traitement de médicament de dosage de médicament d'insuline en bolus (214),
 35 chaque événement respectif d'injection de médicament d'insuline (232) dans la pluralité de dossiers de médicament indique en outre un type respectif de médicament d'insuline (236) injecté au sujet parmi un de (i) un médicament d'insuline à action prolongée et (ii) un médicament d'insuline ordinaire, et
 40 le procédé comprend en outre :

l'identification d'une pluralité d'événements de repas (246) à l'aide de la pluralité de mesures de glycémie autonomes et des horodatages correspondants dans le premier ensemble de données ;
 50 l'application d'une deuxième caractérisation (250) à chaque événement de repas respectif (248) dans la pluralité d'événements de repas, dans lequel
 55 la deuxième caractérisation est l'un d'un traitement adhérent en bolus et d'un traitement non adhérent en bolus,

un repas respectif est considéré comme un traitement adhérent en bolus quand un ou plusieurs dossiers de médication dans la pluralité de dossiers de médication indiquent, sur une base temporelle, une base quantitative et un type de base de médicaments d'insuline, l'adhésion au traitement de dosage de médicament d'insuline en bolus permanent durant le repas respectif, et un repas respectif est considéré un traitement en bolus non adhérent lorsque la pluralité de dossiers de médication échoue à indiquer l'adhésion, sur une base temporelle, une base quantitative, et un type de base de médicament d'insuline, avec le traitement de dosage de médicament d'insuline en bolus permanent durant le repas respectif ; et

l'ajustement du dosage de médicament d'insuline dans le traitement par médicament d'insuline permanent pour le sujet à l'aide de mesures de glycémie dans le premier ensemble de données qui sont temporellement associées à des événements de repas qui sont considérés comme adhérents au traitement en bolus et par l'exclusion des mesures de glycémie dans le premier ensemble de données qui sont temporellement associé à des événements de repas qui sont considérés comme non adhérents au traitement en bolus.

3. Dispositif selon la revendication 1 ou 2, l'appareil comprenant en outre un récepteur sans fil (284), et dans lequel le premier ensemble de données est obtenu sans fil à partir d'un capteur de glycémie (102) attaché au sujet et/ ou le deuxième ensemble de données est obtenu sans fil à partir du ou des stylos d'insuline.

4. Dispositif selon la revendication 2, dans lequel

le premier ensemble de données comprend en outre une pluralité d'événements rétroactifs, chaque événement rétroactif (226) dans la pluralité d'événements rétroactifs représente une instance où le sujet a indiqué qu'il est en train de prendre ou est sur le point de prendre un repas, et
 la pluralité d'événements de repas est vérifiée contre la pluralité d'événements rétroactifs par soit la suppression de tout événement de repas respectif dans la pluralité d'événements de repas qui échouent à correspondre temporellement à tout événement rétroactif dans la pluralité d'événements rétroactifs.

5. Dispositif selon l'une quelconque des revendications

- 1-4, dans lequel les mesures successives dans la pluralité de mesures de glycémie autonomes sont prises chez le sujet à un taux d'intervalle de 5 minutes ou moins, 3 minutes ou moins, ou 1 minute ou moins.
6. Dispositif selon l'une quelconque des revendications 1-5, dans lequel le traitement basal est associé à une pluralité d'époques, le traitement basal spécifique qu'un dosage basal d'insuline à action prolongée (210) doit être pris au cours de chaque époque respective (212) dans la pluralité d'époques, et un événement de jeûne respectif est considéré comme un traitement basal non adhérent lorsqu'il n'y a aucun dossier de médicament dans le deuxième ensemble de données pour l'époque associée à l'événement de jeûne respectif.
7. Dispositif selon la revendication 6, dans lequel chaque époque dans la pluralité d'époques est d'une semaine ou moins, de deux jours ou moins, d'un jour ou moins, ou de 12 heures ou moins.
8. Dispositif selon la revendication 2, dans lequel
- le traitement de dosage de médicament d'insuline spécifique que le médicament d'insuline ordinaire doit être pris jusqu'à une durée de temps prédéterminée avant ou après un repas, et un repas correspondant est considéré comme non adhérent au traitement en bolus lorsqu'il n'y a pas de dossier de médicament d'insuline du type de médicament d'insuline ordinaire ayant un horodatage électronique jusqu'à la durée de temps prédéterminée avant ou après le repas respectif.
9. Dispositif selon la revendication 8, dans lequel la durée prédéterminée de temps est de trente minutes ou moins, de vingt minutes ou moins, ou de quinze minutes ou moins.
10. Dispositif selon la revendication 2, dans lequel
- le médicament d'insuline à action prolongée consiste en un seul médicament d'insuline ayant une durée d'action comprise entre 12 et 24 heures ou un mélange de médicaments d'insuline qui ont collectivement une durée d'action comprise entre 12 et 24 heures, et le médicament d'insuline ordinaire consiste en un seul médicament d'insuline ayant une durée d'action de trois à huit heures ou un mélange de médicaments d'insuline qui ont collectivement une durée d'action comprise entre trois à huit heures.
11. Dispositif selon la revendication 2, dans lequel l'iden-

tification de la pluralité d'événements de repas est effectuée par l'informatique :

- (i) un premier modèle comprenant une estimation de l'écart inverse du taux de glycémie de changement à l'aide de la pluralité de mesures de glycémie autonomes,
- (ii) un deuxième modèle comprenant une estimation de l'écart inverse du taux de glycémie de changement sur base des estimations filtrées de Kalman de glycémie à l'aide de la pluralité de mesures de glycémie autonomes,
- (iii) un troisième modèle comprenant une estimation filtrée de Kalman de glycémie et une estimation filtrée de Kalman du taux de changement (ROC) de glycémie sur base de la pluralité de mesures de glycémie autonomes, ou
- (iv) un quatrième modèle comprenant une estimation filtrée de Kalman de taux de changement de ROC de glycémie sur base de la pluralité de mesures de glycémie autonomes.
12. Dispositif selon la revendication 11, dans lequel le premier modèle, le deuxième modèle, le troisième modèle et le quatrième modèle sont chacun calculés à travers la pluralité de mesures de glycémie autonomes et chaque événement de repas respectif dans la pluralité d'événements de repas est identifié dans une instance où au moins trois des quatre modèles indiquent un événement de repas.
13. Dispositif selon l'une quelconque des revendications 1-12, le procédé comprenant en outre la répétition du procédé de façon continue au fil du temps.
14. Dispositif selon l'une quelconque des revendications 1-13, dans lequel l'identification de la pluralité d'événements de jeûne comprend l'identification d'une première période de jeûne au cours d'une première période de temps englobée par la pluralité de mesures de glycémie autonomes par :

le calcul d'une période changeante de variation σ_k^2 à travers la pluralité de mesures de glycémie autonomes, dans lequel :

$$\sigma_k^2 = \left(\frac{1}{M} \sum_{i=k-M}^k (G_i - \bar{G}) \right)^2$$

dans lequel,

G_i est la i^{th} mesure de glycémie autonome dans une partie k de la pluralité de mesures de glycémie autonomes,

M est un nombre de mesures de glycémie autonomes dans la pluralité de mesures de glycémie et représente une plage de temps prédéterminée contiguë,

\bar{G} est la moyenne des mesures de glycémie autonomes sélectionnées parmi la pluralité de mesures de glycémie autonomes, et k est au cours de la première période de temps ; et

l'association de la première période de jeûne avec une période de variance minimale

$$\min_k \sigma_k^2$$

au cours de la première période de temps.

15. Procédé mis en œuvre par ordinateur fou l'ajustement d'un traitement d'insuline permanent pour un sujet, le traitement de médicament d'insuline permanent comprenant un traitement de dosage de médicament d'insuline basal, le procédé comprenant :

l'obtention d'un premier ensemble de données, le premier ensemble de données comprenant une pluralité de mesures de glycémie autonomes du sujet et, pour chaque mesure de glycémie autonome respective dans la pluralité de mesures de glycémie autonomes, un horodatage représentant le moment où la mesure respective a été effectuée ;

l'obtention d'un deuxième ensemble de données à partir d'un ou de plusieurs stylos d'insuline utilisés par le sujet pour appliquer le traitement d'insuline permanent, le deuxième ensemble de données comprenant une pluralité de dossiers de médicament d'insuline, chaque dossier de médicament d'insuline dans la pluralité de dossiers de médicament comprenant : (i) un événement d'injection de médicament d'insuline respectif comprenant une quantité de médicament d'insuline injectée au sujet à l'aide d'un stylo à insuline respectif parmi le ou les stylos à insuline et (ii) un horodatage électronique correspondant qui est généré automatiquement par le stylo à insuline respectif lors de l'occurrence de l'événement d'injection de médicament d'insuline respectif ;

l'identification d'une pluralité d'événements de jeûne à l'aide de la pluralité de mesures de glycémie autonomes du sujet et des horodatages respectifs dans le premier ensemble de données ;

l'application d'une première caractérisation à chaque événement de jeûne respectif dans la pluralité d'événements de jeûne, dans lequel

la première caractérisation est l'un d'un traitement basal adhérent et d'un traitement basal non adhérent,

un événement de jeûne respectif est considéré comme adhérent au traitement basal lorsque le deuxième ensemble de données comprend un ou plusieurs dossiers de médicament qui établissent, sur une base temporelle et quantitative, l'adhésion au traitement de dosage de médicament d'insuline basal permanent durant l'événement de jeûne respectif, et

un événement de jeûne respectif est considéré comme non-adhérent au traitement basal lorsque le deuxième ensemble de données échoue à comprendre un ou plusieurs dossiers de médicaments qui établissent, sur une base temporelle et quantitative, l'adhésion au traitement de dosage de médicament d'insuline basal permanent durant l'événement de jeûne respectif, et ; et

l'ajustement d'un dosage de médicament d'insuline dans le traitement de médicament d'insuline basal pour le sujet sur base des mesures de glycémie dans le premier ensemble de données, qui sont contemporaines avec les événements de jeûne qui sont considérés comme étant un traitement basal adhérent et par l'exclusion des mesures de glycémie dans le premier ensemble de données qui sont contemporaines avec des événements de jeûne qui sont considérés comme non adhérents au traitement basal.

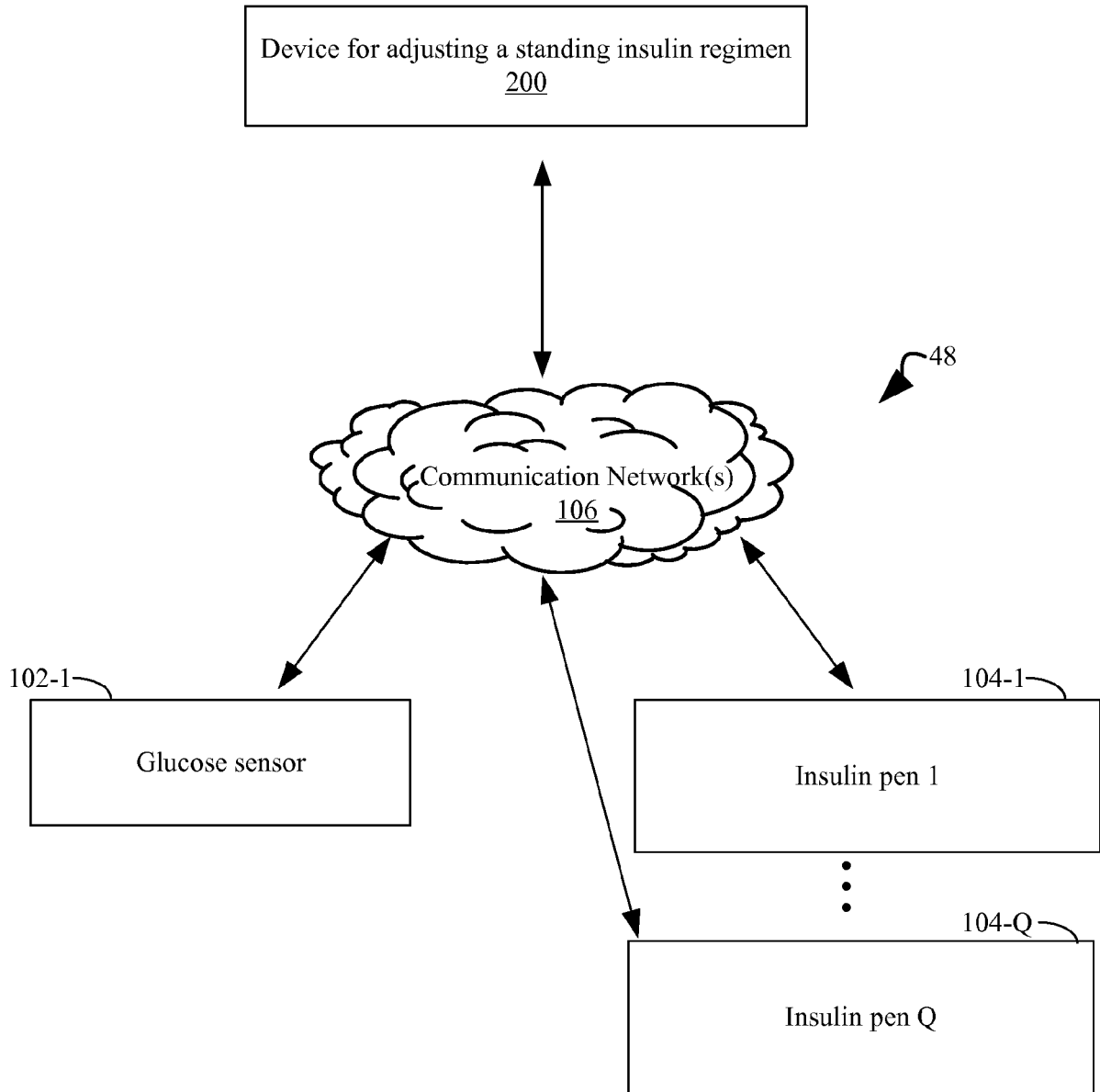

Fig. 1

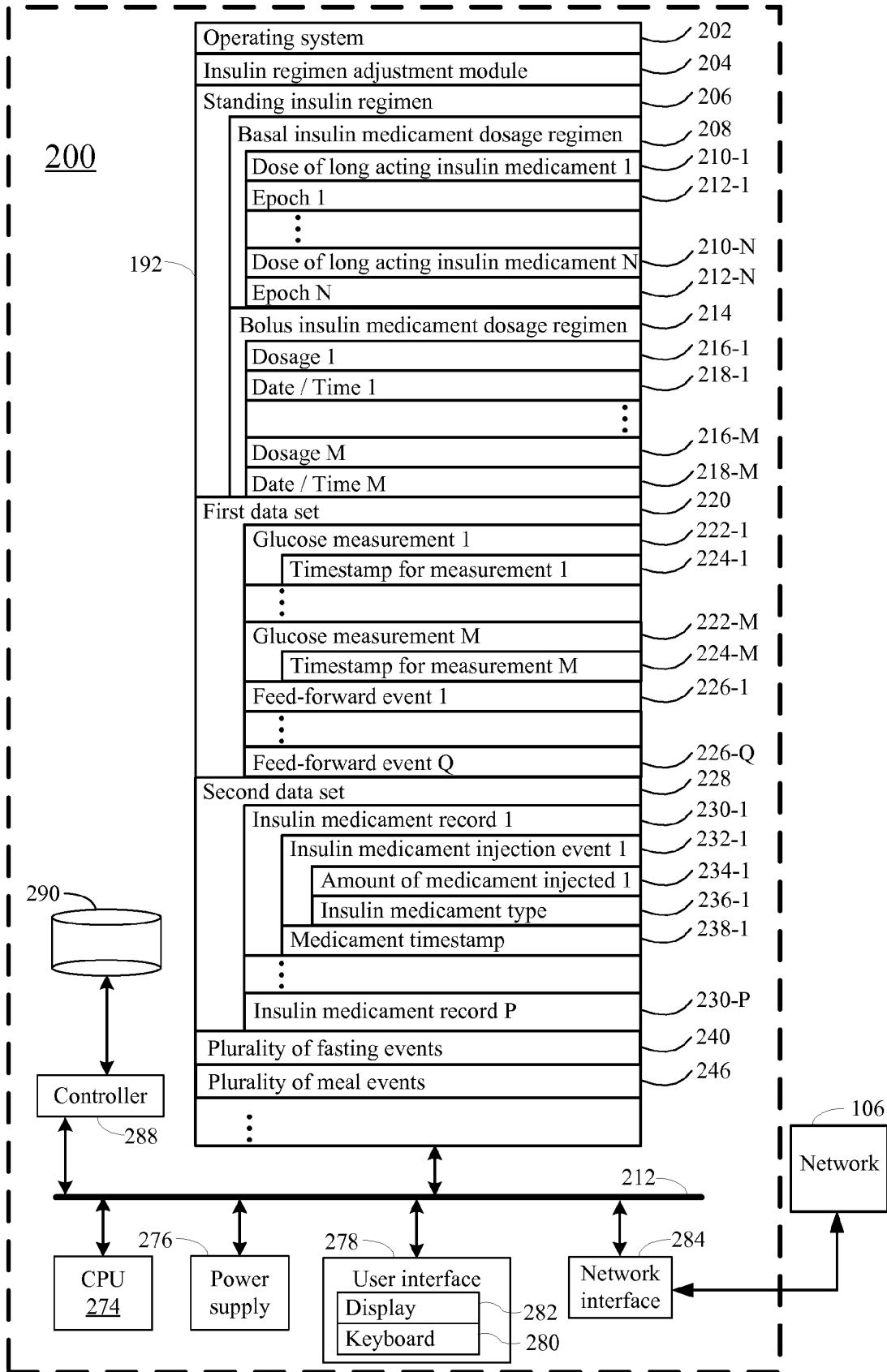

Fig. 2

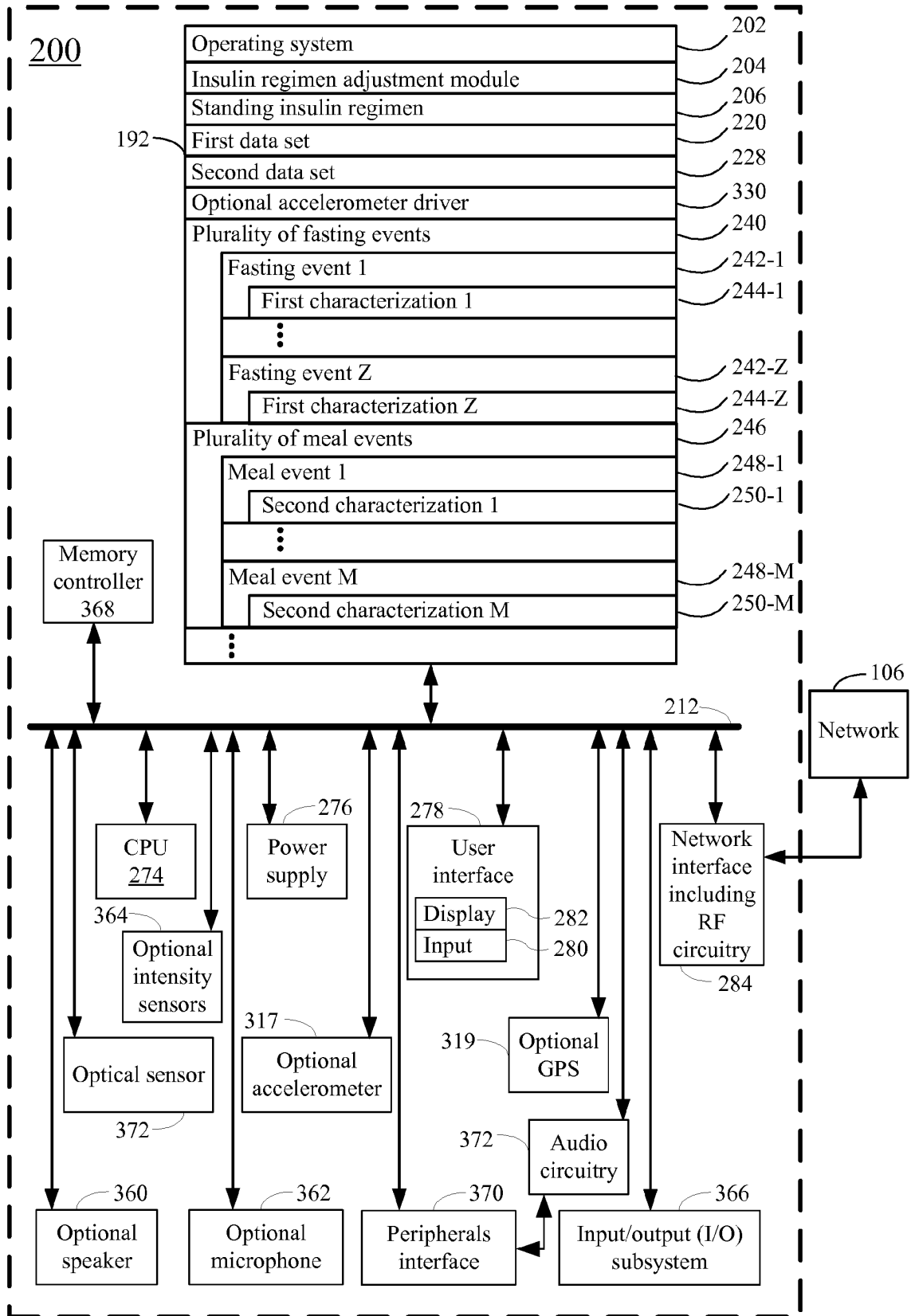

Fig. 3

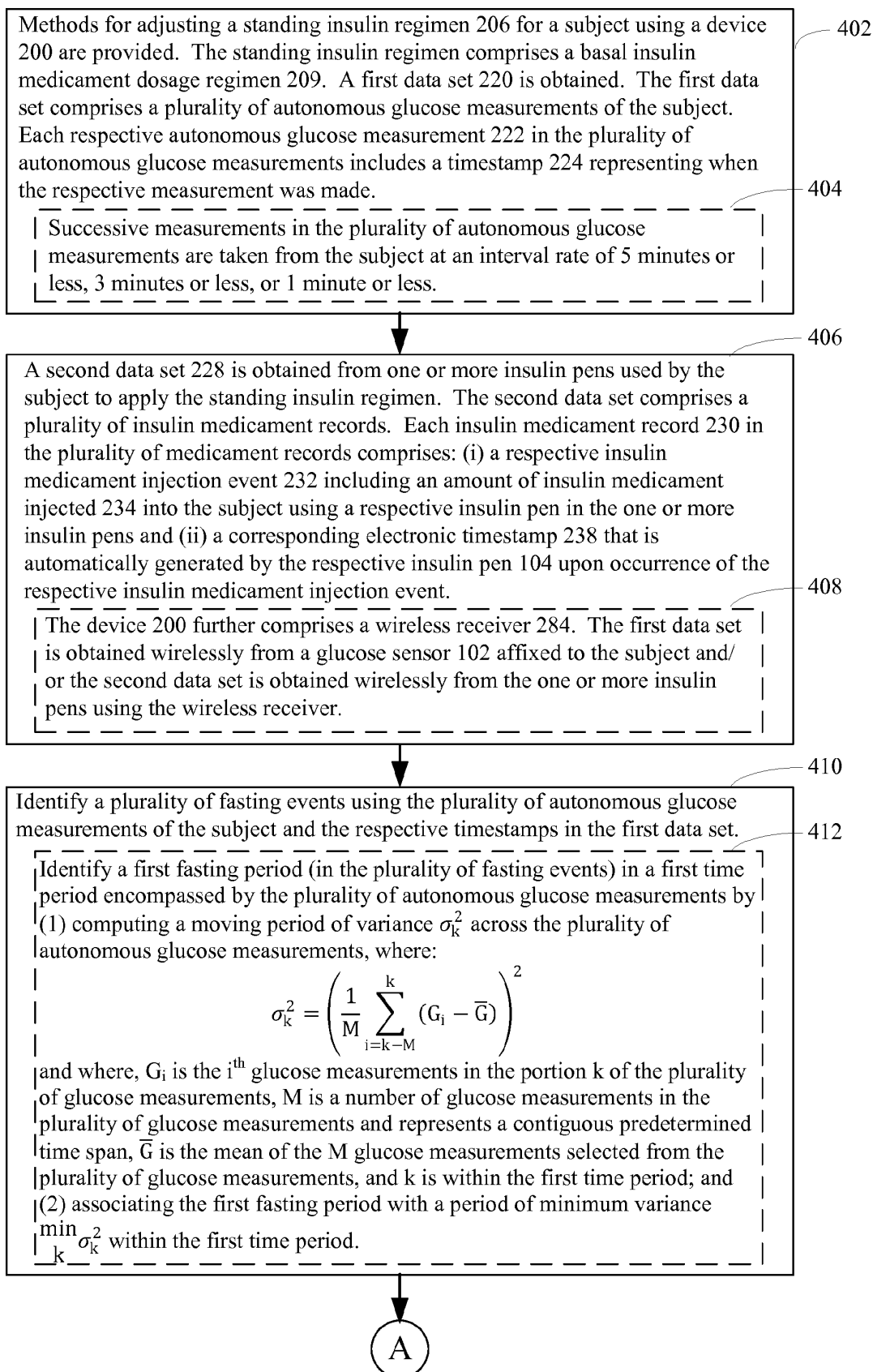

Fig. 4A

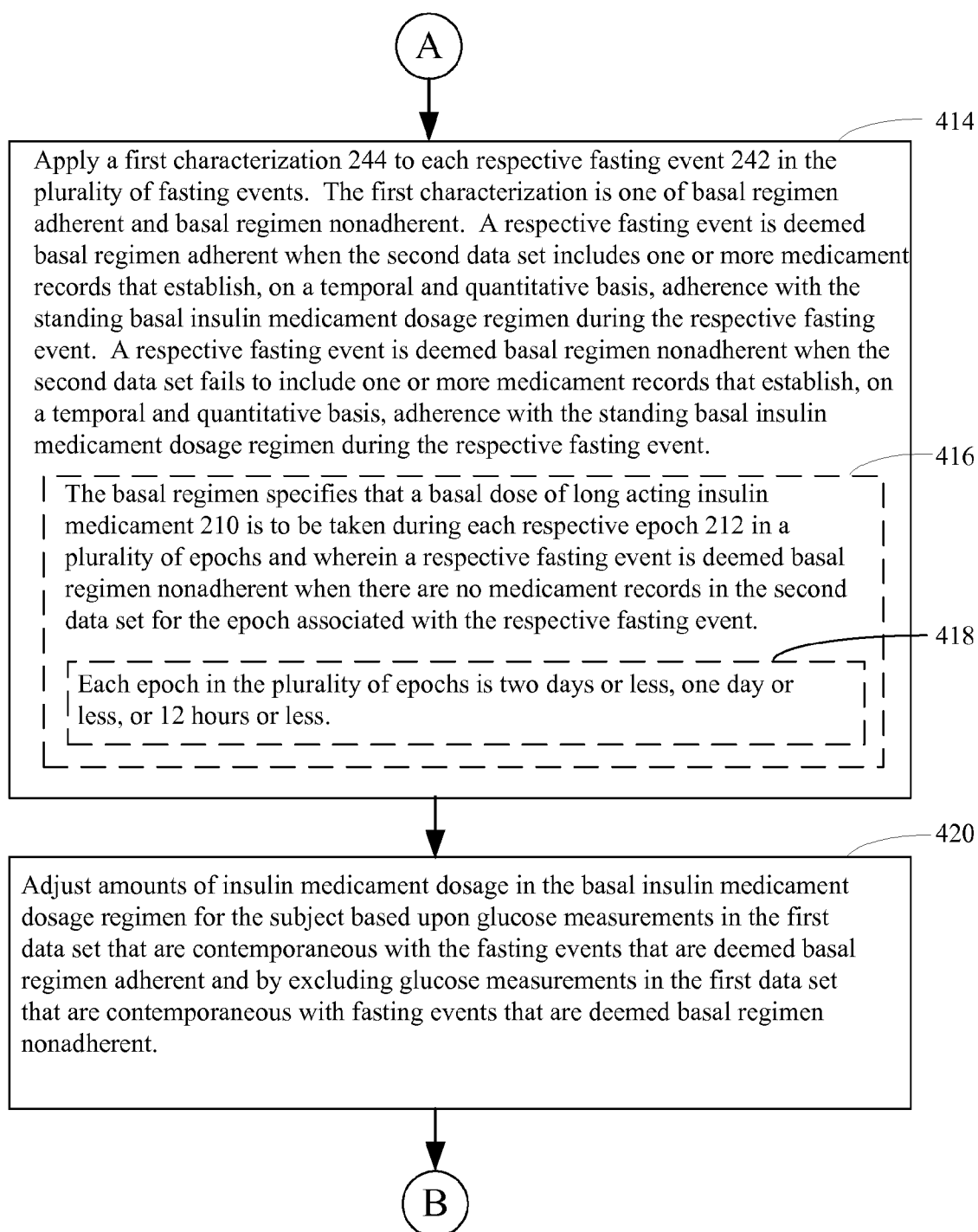

Fig. 4B

B

420
(cont.)

422

The standing insulin regimen further comprises a bolus insulin medicament dosage regimen 214. Each respective insulin medicament injection event 232 in the plurality of medicament records further indicates a respective type of insulin medicament 236 injected into the subject from one of (i) a long acting insulin medicament and (ii) a short acting insulin medicament. The method further comprises:

- identifying a plurality of meal events 246 using the plurality of autonomous glucose measurements and the corresponding timestamps in the first data set;
- applying a second characterization 250 to each respective meal event 248 in the plurality of meal events, where the second characterization is one of bolus regimen adherent and bolus regimen nonadherent, a respective meal is deemed bolus regimen adherent when one or more medicament records in the plurality of medicament records indicates, on a temporal basis, a quantitative basis and a type of insulin medicament basis, adherence with the standing bolus insulin medicament dosage regimen during the respective meal, and a respective meal is deemed bolus regimen nonadherent when the plurality of medicament records fails to indicate adherence, on a temporal basis, a quantitative basis, and a type of insulin medicament basis, with the standing bolus insulin medicament dosage regimen during the respective meal; and
- adjusting insulin medicament dosage in the bolus insulin medicament dosage regimen for the subject by using glucose measurements in the first data set that are temporally associated with meal events that are deemed bolus regimen adherent and by excluding glucose measurements in the first data set that are temporally associated with meal events that are deemed bolus regimen nonadherent.

424

The first data set further comprises a plurality of feed-forward events, each respective feed-forward event 226 in the plurality of feed-forward events represents an instance where the subject has indicated they are having or are about to have a meal. The plurality of meal events are verified against the plurality of feed-forward events by either removing any respective meal event in the plurality of meal events that fails to temporally match any feed-forward event in the plurality of feed-forward events.

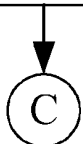

C

Fig. 4C

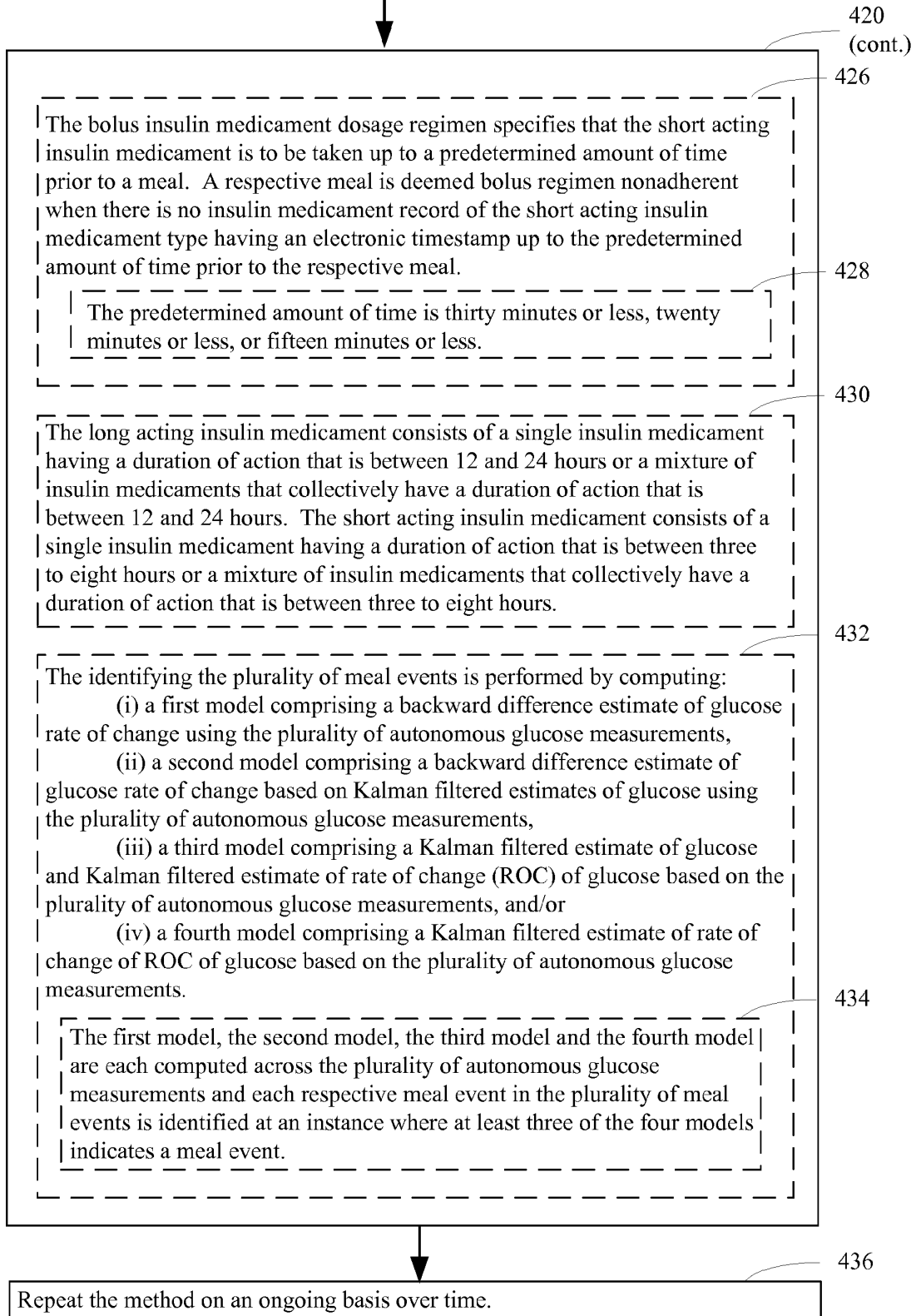

Fig. 4D

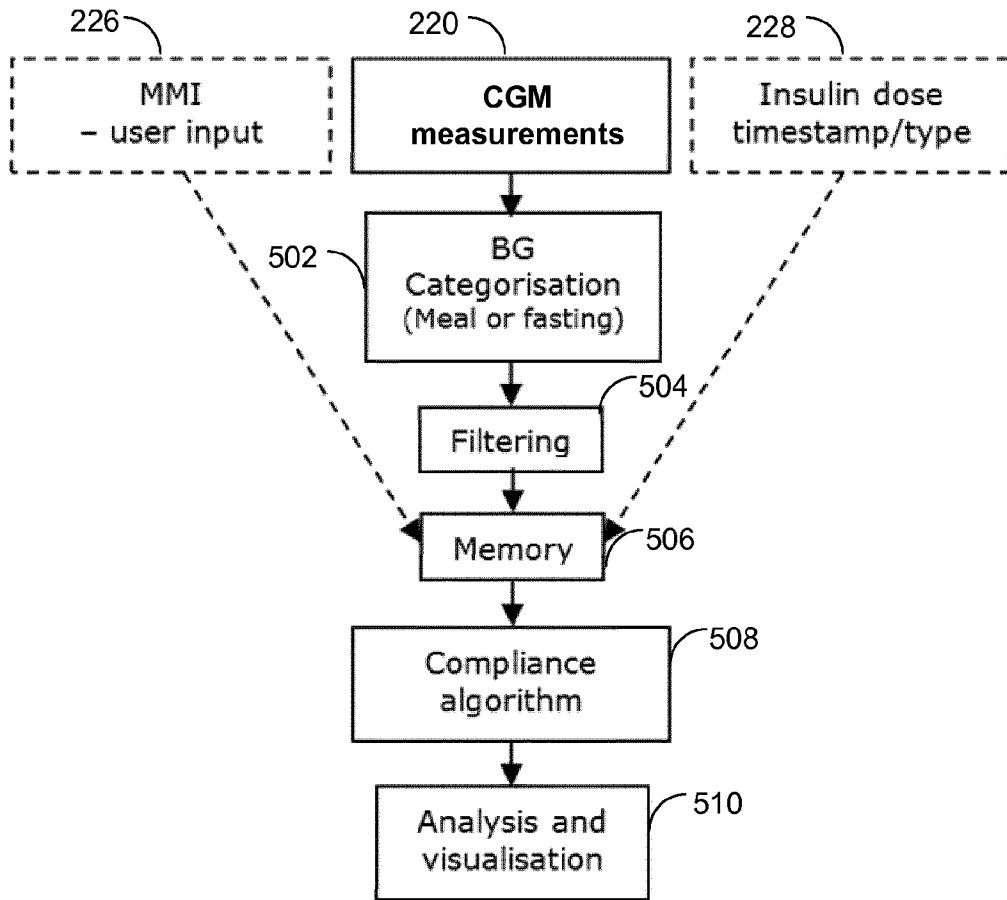

Fig. 5

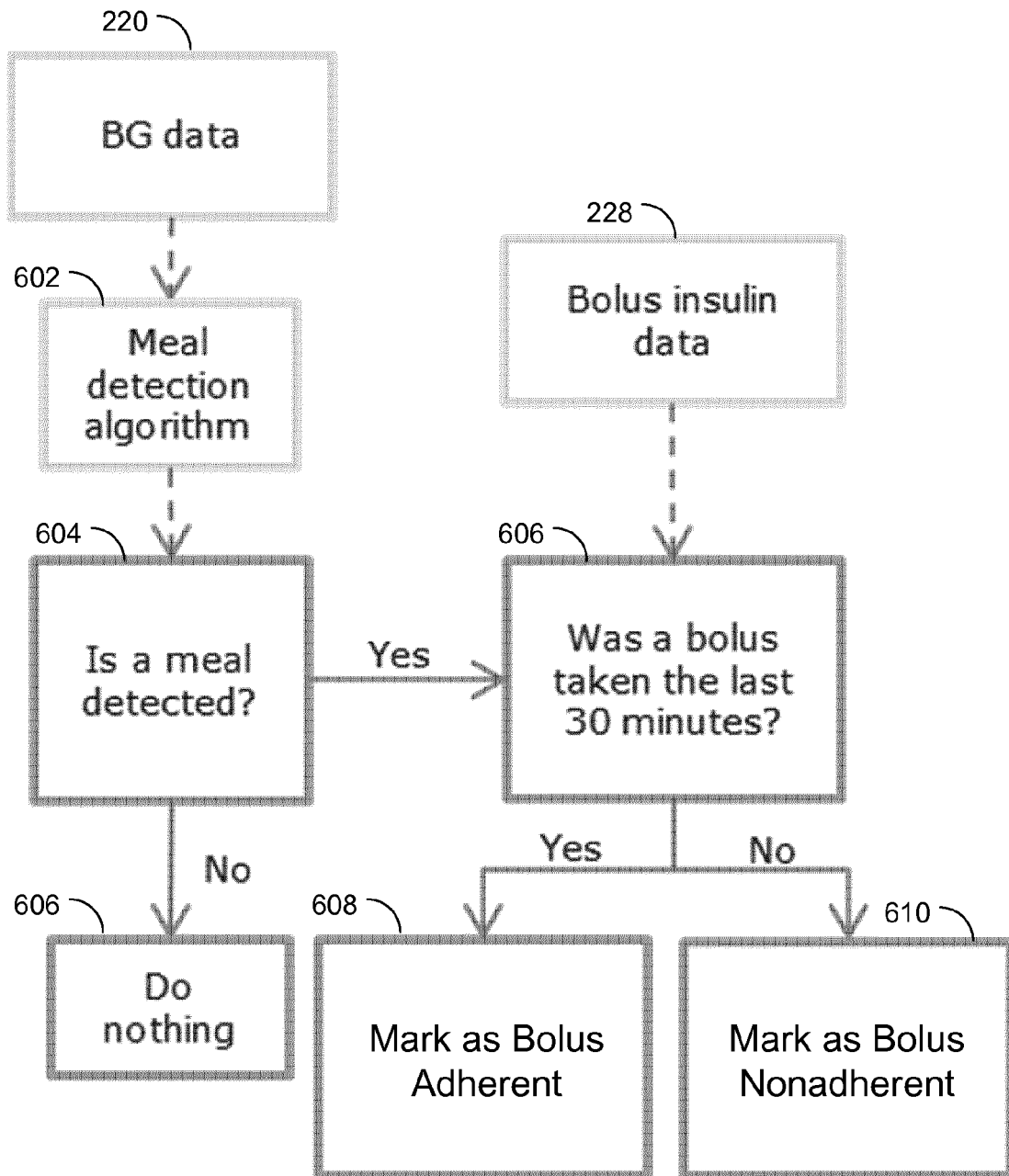

Fig. 6

Meal detection
algorithm flags
a meal



Meal is
ingested



Event mark:
Bolus Adherent

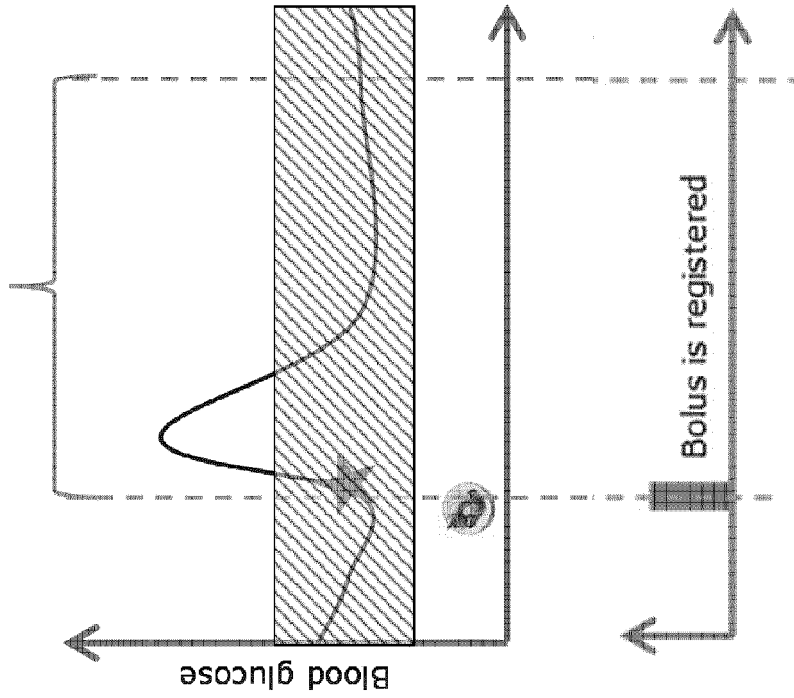

Event mark:
Bolus Nonadherent

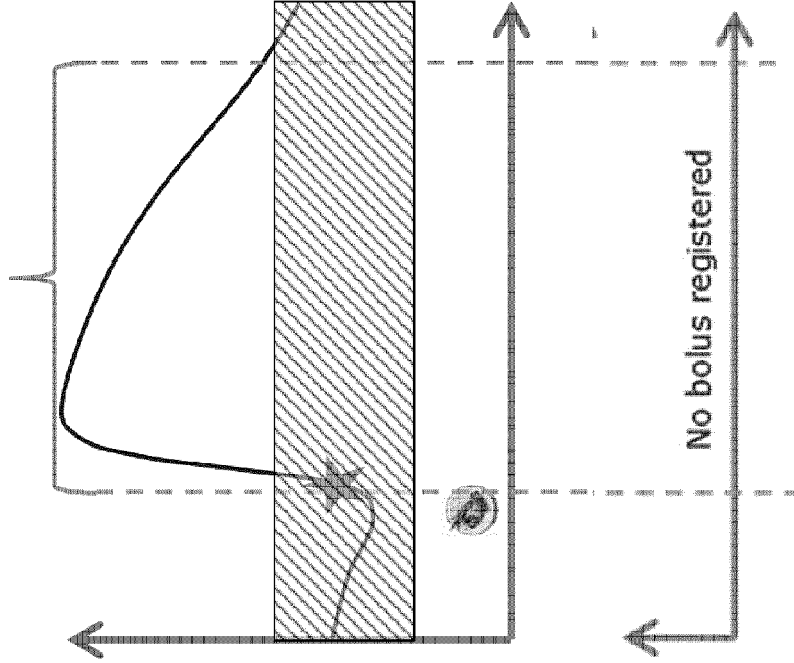

Fig. 7

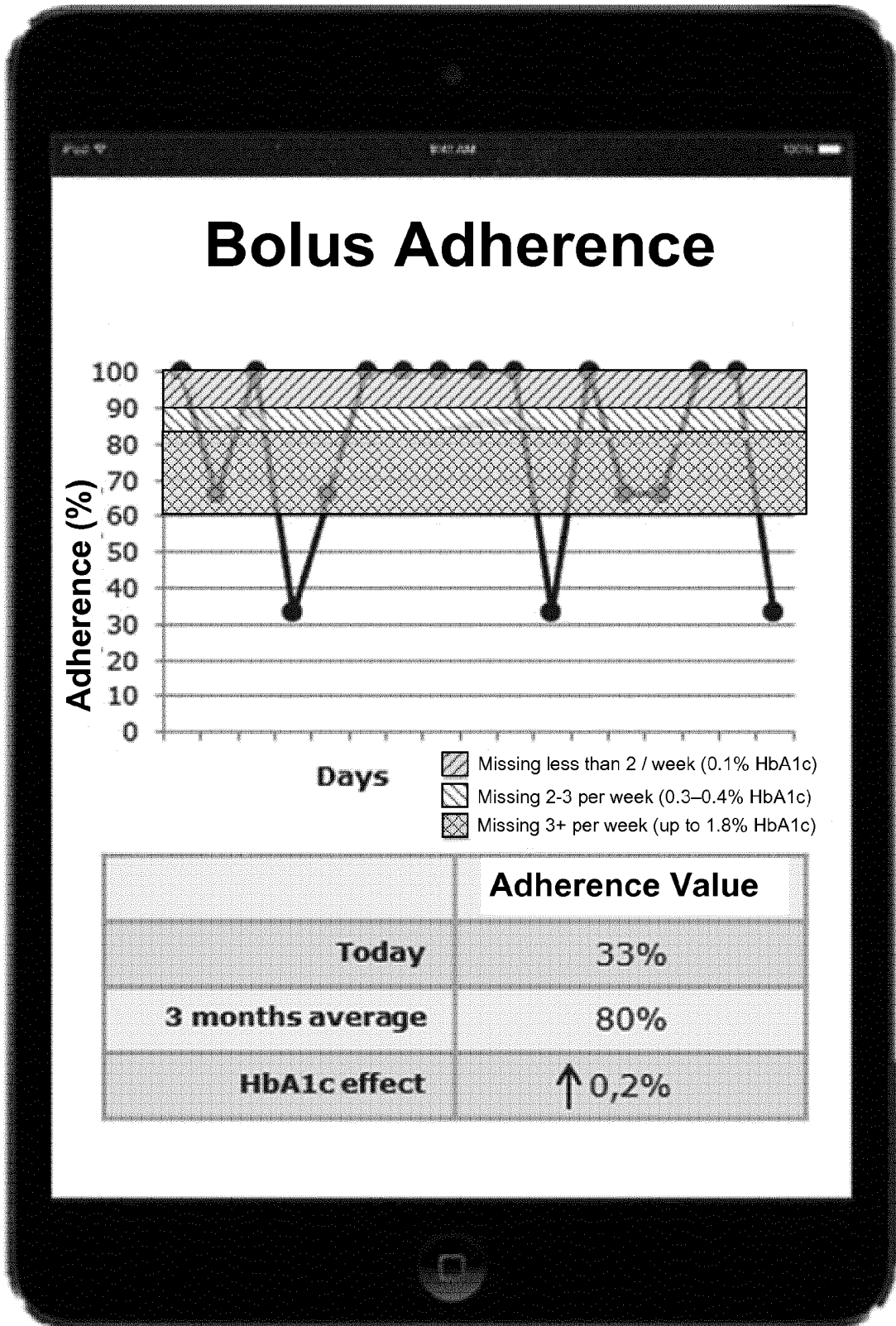

Fig. 8

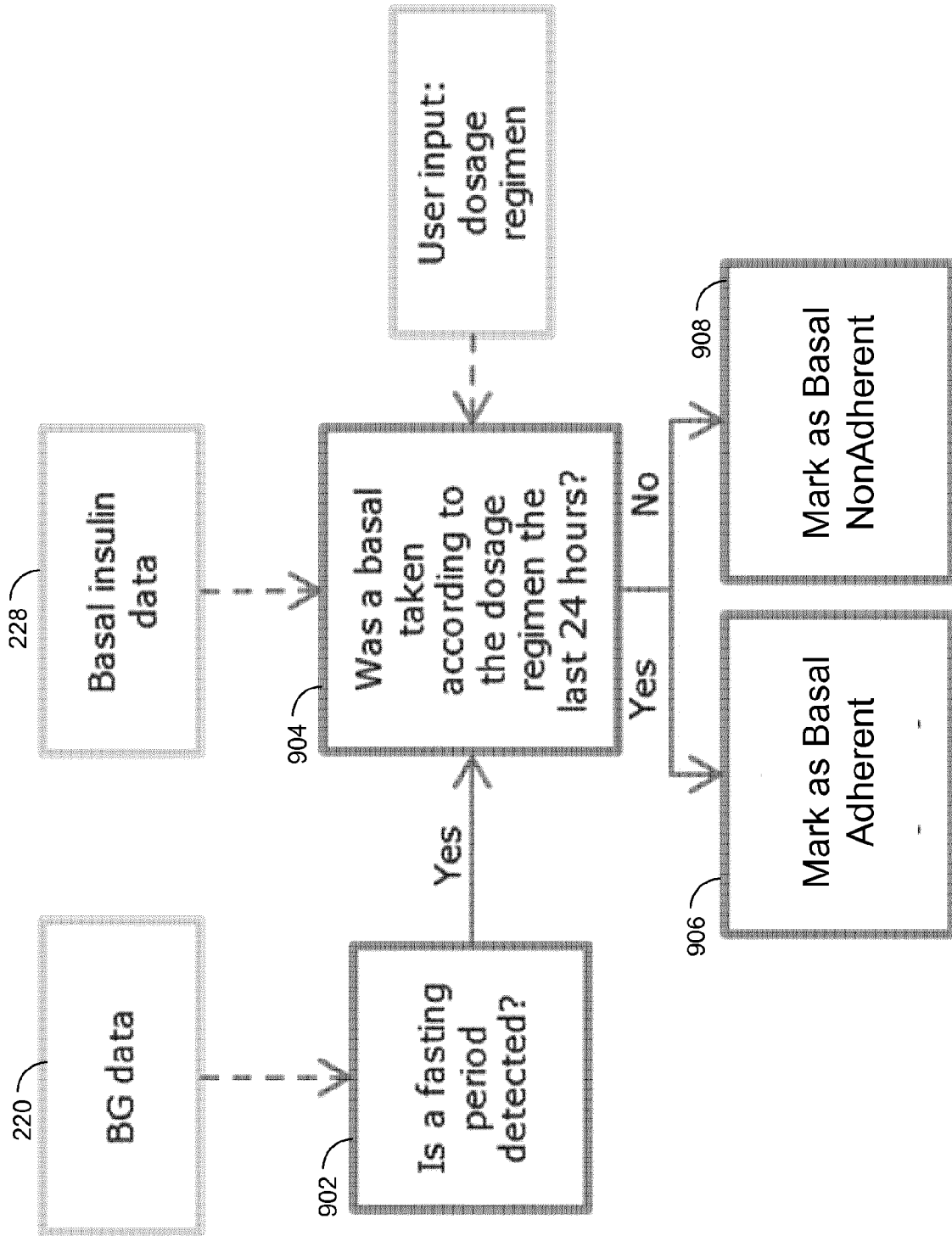

Fig. 9

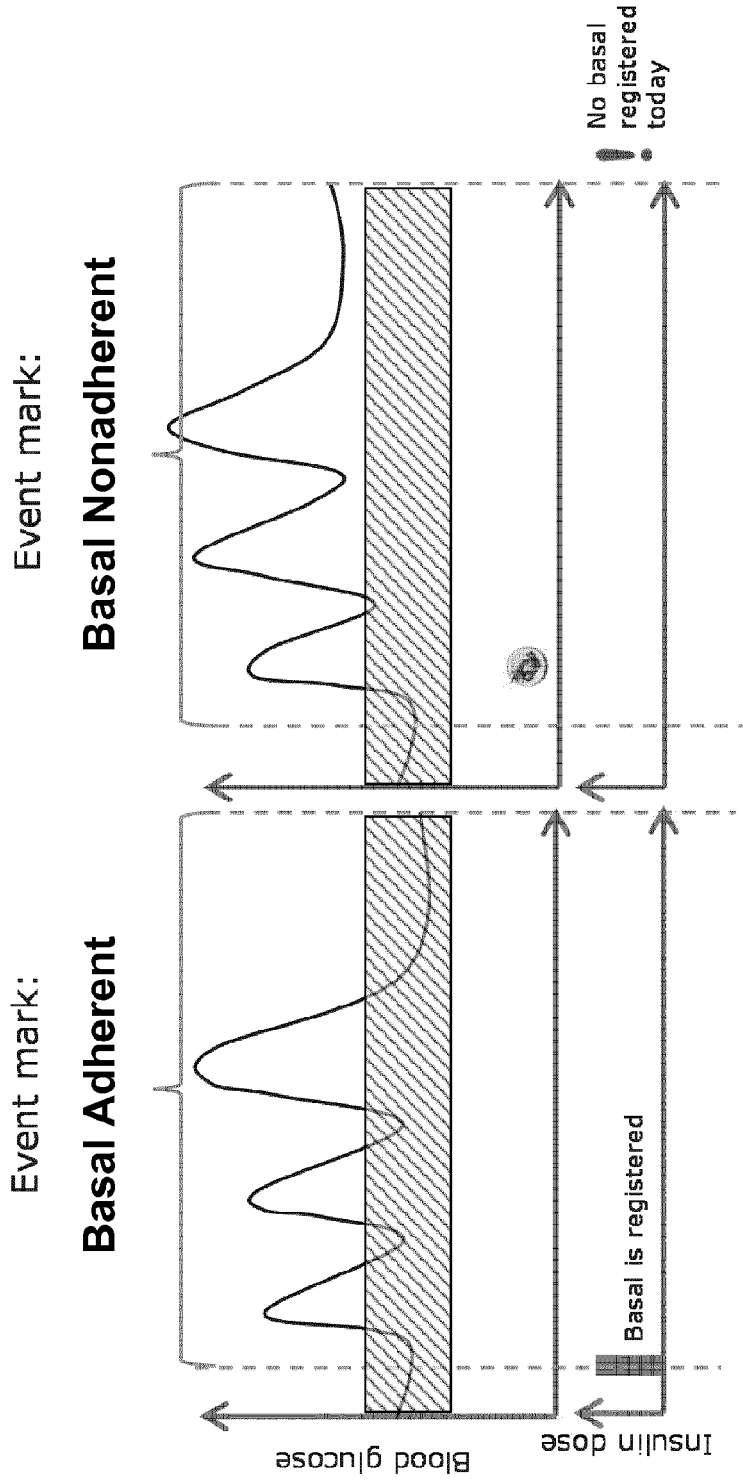

Fig. 10

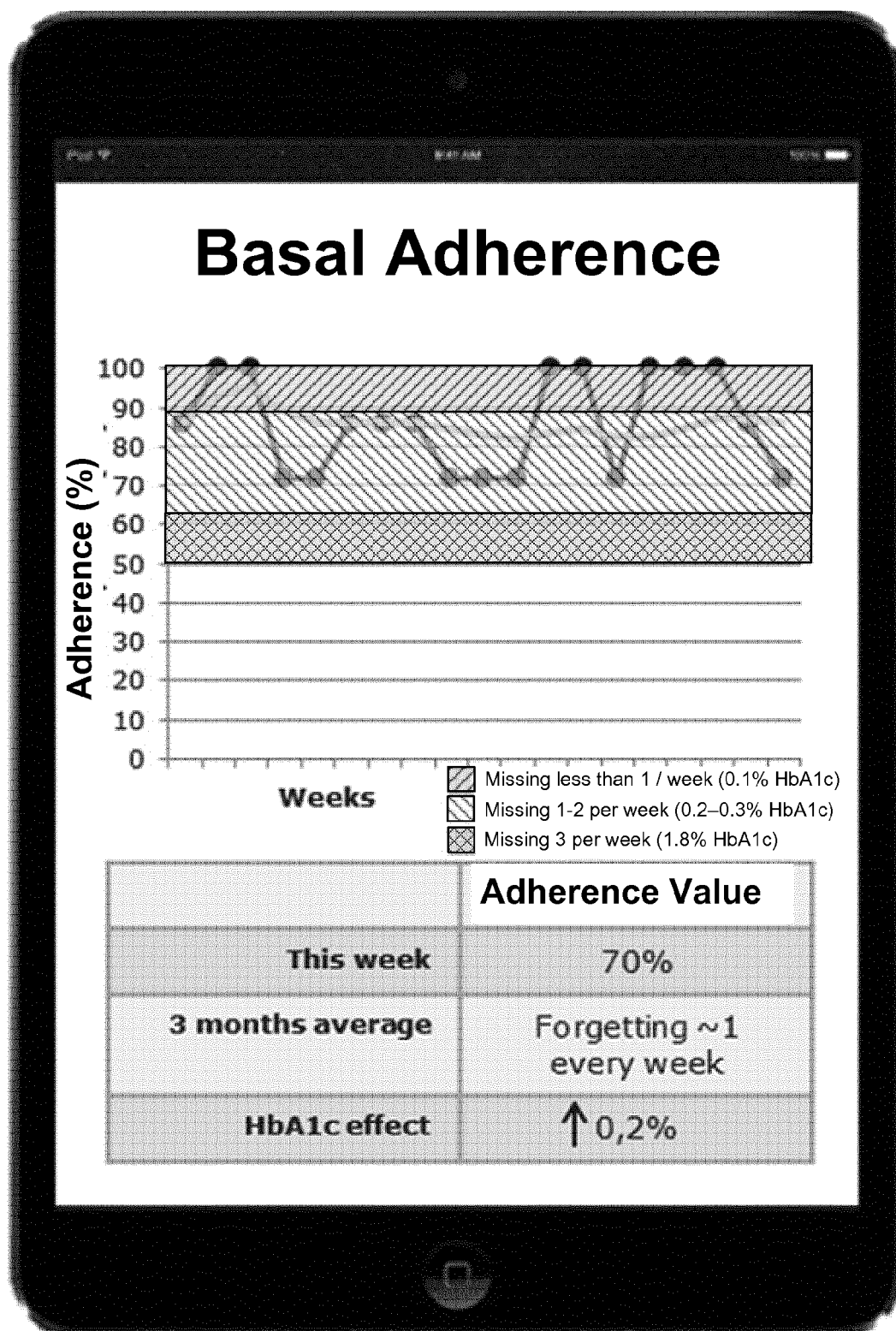

Fig. 11

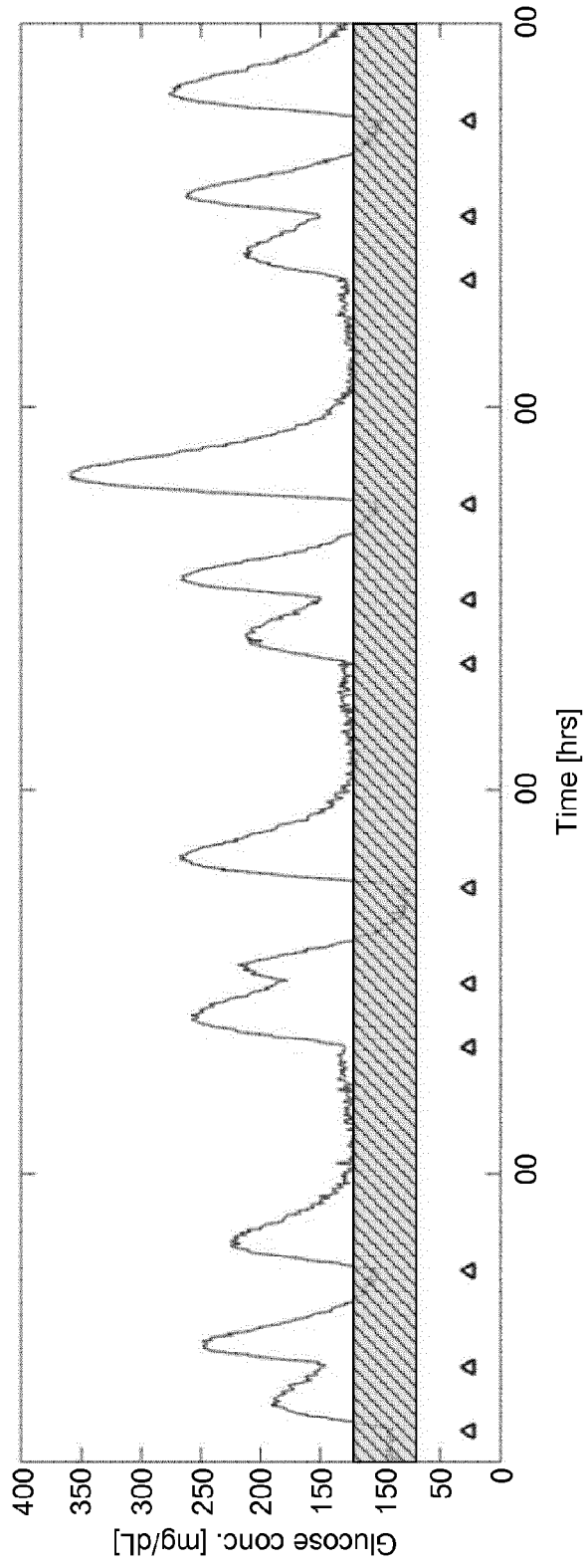

Fig. 12

REFERENCES CITED IN THE DESCRIPTION

This list of references cited by the applicant is for the reader's convenience only. It does not form part of the European patent document. Even though great care has been taken in compiling the references, errors or omissions cannot be excluded and the EPO disclaims all liability in this regard.

Patent documents cited in the description

- US 2015006462 A1 [0010]
- WO 2012152628 A1 [0011]

Non-patent literature cited in the description

- **SCHMID**. New options in insulin therapy. *J Pediatrics (Rio J)*, 2007, vol. 83 (5), S146-S155 [0086]
- **PLANK et al.** A double-blind, randomized, dose-response study investigating the pharmacodynamic and pharmacokinetic properties of the long-acting insulin analog detemir. *Diabetes Care*, 2005, vol. 28, 1107-1112 [0086]
- **HELMS KELLEY**. Insulin glulisine: an evaluation of its pharmacodynamic properties and clinical application. *Ann Pharmacother*, 2009, vol. 43, 658-668 [0086]
- **GERICH**. Novel insulins: expanding options in diabetes management. *Am J Med.*, 2002, vol. 113, 308-316 [0086]
- **DASSAU et al.** Detection of a Meal Using Continuous Glucose Monitoring. *Diabetes Care*, 2008, vol. 31, 295-300 [0087]
- **CAMERON et al.** Probabilistic Evolving Meal Detection and Estimation of Meal Total Glucose Appearance. *Journal of Diabetes Science and Technology*, 2009, vol. 3 (5), 1022-1030 [0087]

专利名称(译)	基于葡萄糖测量和胰岛素笔数据的胰岛素治疗的方案依从性测量		
公开(公告)号	EP3479267A1	公开(公告)日	2019-05-08
申请号	EP2017735028	申请日	2017-06-22
[标]申请(专利权)人(译)	诺沃挪第克公司		
申请(专利权)人(译)	诺和诺德公司A / S		
当前申请(专利权)人(译)	诺和诺德公司A / S		
[标]发明人	BENGTSSON HENRIK ARADOTTIR TINNA BJORK		
发明人	BENGTSSON, HENRIK ARADÓTTIR, TINNA, BJÖRK		
IPC分类号	G06F19/00 A61B5/145 G16H20/17 A61B5/00 G16H50/20		
CPC分类号	A61B5/14532 A61B5/4839 G16H20/17 G16H50/20		
优先权	2016177080 2016-06-30 EP		
其他公开文献	EP3479267B1		
外部链接	Espacenet		

摘要(译)

提供了用于调节受试者的常规胰岛素药物剂量方案的系统和方法。使用受试者在第一数据集中的带有时间戳的自主葡萄糖测量来识别禁食事件。来自用于实施站立方案的一根或多根胰岛素笔的第二数据集包括记录，每个记录包括带时间戳的事件，该事件指定了注射的胰岛素药物的量。每个禁食事件的特征是依从的或不依从的。当第二数据集包括一个或多个记录，该记录在空腹事件期间在时间和数量上建立了对站立方案的依从性时，则发生空腹事件。相反，当第二数据集未能在时间和数量上建立起站立方案的依从性时，就不会发生禁食事件。使用与禁食事件同时发生的葡萄糖测量值，以及排除与非禁食事件同时发生的葡萄糖测量值，可以调整站立方案的剂量。