



(11) **EP 1 711 790 B1**

(12) **EUROPEAN PATENT SPECIFICATION**

(45) Date of publication and mention of the grant of the patent:
08.09.2010 Bulletin 2010/36

(21) Application number: **04812899.5**

(22) Date of filing: **03.12.2004**

(51) Int Cl.:
G01N 1/00 (2006.01)

(86) International application number:
PCT/US2004/040476

(87) International publication number:
WO 2005/057168 (23.06.2005 Gazette 2005/25)

(54) **CALIBRATION TECHNIQUES FOR A CONTINUOUS ANALYTE SENSOR**

KALIBRATIONSMETHODEN FÜR EINEN KONTINUIERLICH ARBEITENDEN ANALYTSSENSOR
TECHNIQUES D'ETALONNAGE POUR UN CAPTEUR DE SUBSTANCES A ANALYSER EN CONTINU

(84) Designated Contracting States:
AT BE BG CH CY CZ DE DK EE ES FI FR GB GR HU IE IS IT LI LT LU MC NL PL PT RO SE SI SK TR

(30) Priority: **05.12.2003 US 527323 P**
13.07.2004 US 587787 P
30.09.2004 US 614683 P

(43) Date of publication of application:
18.10.2006 Bulletin 2006/42

(60) Divisional application:
10168368.8
10168369.6
10168371.2

(73) Proprietor: **DexCom, Inc.**
San Diego,
California 92121 (US)

(72) Inventors:
• **KAMATH, Apurv, Ullas**
Solana Beach, California 92075 (US)
• **SIMPSON, Peter, C.**
Del Mar, California 92014 (US)
• **BRAUKER, James, H.**
San Diego, California 92131 (US)
• **GOODE, JR., Paul, V.**
Murrieta, California 92563 (US)

(74) Representative: **Smaggasgale, Gillian Helen**
W.P. Thompson & Co
55 Drury Lane
London WC2B 5SQ (GB)

(56) References cited:
US-A- 6 001 067 US-A- 6 081 736
US-A- 6 088 608 US-A1- 2003 187 338
US-B1- 6 233 471

EP 1 711 790 B1

Note: Within nine months of the publication of the mention of the grant of the European patent in the European Patent Bulletin, any person may give notice to the European Patent Office of opposition to that patent, in accordance with the Implementing Regulations. Notice of opposition shall not be deemed to have been filed until the opposition fee has been paid. (Art. 99(1) European Patent Convention).

DescriptionField of the Invention

5 **[0001]** The present invention relates generally to systems and methods for processing analyte sensor data.

Background of the Invention

10 **[0002]** Diabetes mellitus is a disorder in which the pancreas cannot create sufficient insulin (Type I or insulin dependent) and/or in which insulin is not effective (Type 2 or non-insulin dependent). In the diabetic state, the victim suffers from high blood sugar, which may cause an array of physiological derangements (for example, kidney failure, skin ulcers, or bleeding into the vitreous of the eye) associated with the deterioration of small blood vessels. A hypoglycemic reaction (low blood sugar) may be induced by an inadvertent overdose of insulin, or after a normal dose of insulin or glucose-lowering agent accompanied by extraordinary exercise or insufficient food intake.

15 **[0003]** Conventionally, a diabetic person carries a self-monitoring blood glucose (SMBG) monitor, which typically comprises uncomfortable finger pricking methods. Due to the lack of comfort and convenience, a diabetic will normally only measure his or her glucose level two to four times per day. Unfortunately, these time intervals are so far spread apart that the diabetic will likely find out too late, sometimes incurring dangerous side effects, of a hyper- or hypo-glycemic condition. In fact, it is not only unlikely that a diabetic will take a timely SMBG value, but the diabetic will not know if their blood glucose value is going up (higher) or down (lower) based on conventional methods, inhibiting their ability to make educated insulin therapy decisions.

20 US 2003/0187338 discloses an analyte monitor which includes a sensor, a sensor controlled unit, and a display unit. The sensor may have a substrate, a recessed channel formed in the substrate and conductive material disposed in the recess channel to form a working electrode. The sensor control unit typically has a housing adapted for placement on skin and is adapted to receive a portion of an electrochemical sensor. The sensor control unit also includes two or more conductive contacts disposed on the housing and configured for coupling to two or more contact pads on the sensor. A transmitter is disposed in the housing and coupled to the plurality of the contacts for transmitting data obtained using the sensor. The display unit has a receiver for receiving data transmitted by the transmitter of the sensor control unit and a display coupled to the receiver for displaying and indication of a level of an analyte. The analyte monitor may also be part of a drug delivery system to alter the level of the analyte based on the data obtained using the sensor.

Summary of the Invention

35 **[0004]** A variety of continuous glucose sensors have been developed for detecting and/or quantifying glucose concentration in a host. These sensors have typically required one or more blood glucose measurements, or the like, from which to calibrate the continuous glucose sensor to calculate the relationship between the current output of the sensor and blood glucose measurements, to provide meaningful values to a patient or doctor. Unfortunately, continuous glucose sensors are conventionally also sensitive to non-glucose related changes in the baseline current and sensitivity over time, for example, due to changes in a host's metabolism, maturation of the tissue at the biointerface of the sensor, interfering species which cause a measurable increase or decrease in the signal, or the like. Therefore, in addition to initial calibration, continuous glucose sensors should be responsive to baseline and/or sensitivity changes over time, which requires recalibration of the sensor. Consequently, users of continuous glucose sensors have typically been required to obtain numerous blood glucose measurements daily and/or weekly in order to maintain calibration of the sensor over time.

40 **[0005]** The preferred embodiments provide improved calibration techniques that utilize electrode systems and signal processing that provides measurements useful in simplifying and updating calibration that allows the patient increased convenience (for example, by requiring fewer reference glucose values) and confidence (for example, by increasing accuracy of the device).

45 **[0006]** The present invention relates to a sensor configured for insertion into a host for measuring an analyte in the host, the sensor comprising:

a first working electrode configured to generate a first signal associated with an analyte related electroactive compound and a non-analyte related electroactive compound, wherein the first electrode is disposed beneath an active enzymatic portion of a membrane system on the sensor;

50 a second working electrode configured to generate a second signal associated with the non-analyte related electroactive compound, wherein the second electrode is disposed beneath an inactive- or non-enzymatic portion of the membrane system on the sensor; and

electronics operably connected to the first and second working electrodes, wherein the electronics are configured

to calculate at least one analyte sensor data point;
wherein the first and second working electrodes are juxtapositioned and/or twisted around each other.

5 In one embodiment, the second signal is indicative of a presence or absence of a water-soluble analyte. The water-soluble analyte may comprise urea. In one embodiment, the second signal is measured at an oxygen-measuring electrode disposed beneath a non-enzymatic portion of the membrane system. In one embodiment, the glucose-measuring electrode incrementally measures oxygen, whereby the second signal is measured. In one embodiment, the second signal is measured at an oxygen sensor disposed beneath the membrane system. In one embodiment, the sensitivity change is calculated as a glucose-to-oxygen ratio, whereby an oxygen threshold is determined that is indicative of a stability of the glucose sensor. One embodiment further comprises filtering the first signal responsive to the stability of the glucose sensor. One embodiment further comprises displaying a glucose value derived from the first signal, wherein the display is suspended depending on the stability of the glucose sensor. One embodiment further comprises calibrating the first signal, wherein the calibrating step is suspended when the glucose sensor is determined to be stable. One embodiment further comprises calibrating the glucose sensor when the sensitivity change exceeds a preselected value. The step of calibrating may comprise receiving a reference signal from a reference analyte monitor, the reference signal comprising at least one reference data point. The step of calibrating may comprise using the sensitivity change to calibrate the glucose sensor. The step of calibrating may be performed repeatedly at a frequency responsive to the sensitivity change. One embodiment further comprises determining a stability of glucose transport through the membrane system, wherein the stability of glucose transport is determined by measuring the sensitivity change over a time period. One embodiment further comprises a step of prohibiting calibration of the glucose sensor when glucose transport is determined to be unstable. One embodiment further comprises a step of filtering at least one glucose-related sensor data point when glucose transport is determined to be unstable.

[0007] The sensor is useful in a method for processing data from a glucose sensor in a host, comprising: 1) measuring a first signal associated with glucose and non-glucose related electroactive compounds, wherein the first signal is measured at a first electrode disposed beneath an active enzymatic portion of a membrane system; 2) measuring a second signal associated with a non-glucose related electroactive compound, wherein the second signal is measured at a second electrode that is disposed beneath a non-enzymatic portion of the membrane system; and 3) monitoring the second signal over a time period, whereby a change in the non-glucose related electroactive compound in the host is measured. The method may comprise a step of subtracting the second signal from the first signal, whereby a differential signal comprising at least one glucose sensor data point is determined. The step of subtracting may be performed electronically in the sensor. Alternatively, the step of subtracting may be performed digitally in the sensor or an associated receiver. The method may further comprise calibrating the glucose sensor, wherein the step of calibrating comprises: 1) receiving reference data from a reference analyte monitor, the reference data comprising at least two reference data points; 2) providing at least two matched data pairs by matching the reference data to substantially time corresponding sensor data; and 3) calibrating the glucose sensor using the two or more matched data pairs and the differential signal. The method may further comprise a step of calibrating the glucose sensor in response to a change in the non-glucose related electroactive compound over the time period. The step of calibrating may comprise receiving reference data from a reference analyte monitor, the reference data comprising at least one reference data point. The step of calibrating may comprise using the change in the non-glucose related electroactive compound over the time period to calibrate the glucose sensor. The step of calibrating may be performed repeatedly at a frequency, wherein the frequency is selected based on the change in the non-glucose related electroactive compound over the time period. The method may further comprise prohibiting calibration of the glucose sensor when the change in the non-glucose related electroactive compound rises above a threshold during the time period. The method may further comprise filtering the glucose sensor data point when the change in the non-glucose related electroactive compound rises above a threshold during the time period. The method may further comprise; measuring a third signal in the host by obtaining at least one non-glucose constant data point, wherein the third signal is measured beneath the membrane system. The method may further comprise monitoring the third signal over a time period, whereby a sensitivity change associated with solute transport through the membrane system is measured. An oxygen-measuring electrode may be disposed beneath the non-enzymatic portion of the membrane system to measure the third signal. The first electrode may measure the third signal by incrementally measuring oxygen.

50 An oxygen sensor disposed beneath the membrane system may measure the third signal. The method may further comprise determining whether a glucose-to-oxygen ratio exceeds a threshold level by calculating a value from the first signal and the second signal, wherein the value is indicative of the glucose-to-oxygen ratio. The method may further comprise calibrating the glucose sensor in response to the sensitivity change measured over a time period. The step of calibrating may comprise receiving reference data from a reference analyte monitor, the reference data comprising at least one reference data point. The step of calibrating may comprise using the sensitivity change. The step of calibrating may be performed repeatedly at a frequency, wherein the frequency is selected based on the sensitivity change. The method may further comprise determining a glucose transport stability through the membrane system, wherein the

glucose transport stability corresponds to the sensitivity change over a period of time. The method may further comprise prohibiting calibration of the glucose sensor when the glucose transport stability falls below a threshold. The method may further comprise filtering the glucose-related sensor data point when the glucose transport stability falls below a threshold.

5

Brief Description of the Drawing

[0008] Fig. 1A is a perspective view of a continuous analyte sensor, including an implantable body with a membrane system disposed thereon

10 **[0009]** Fig. 1B is an expanded view of an alternative embodiment of a continuous analyte sensor, illustrating the *in vivo* portion of the sensor.

[0010] Fig. 2A is a schematic view of a membrane system in one embodiment, configured for deposition over the electroactive surfaces of the analyte sensor of Fig. 1A.

15 **[0011]** Fig. 2B is a schematic view of a membrane system in an alternative embodiment, configured for deposition over the electroactive surfaces of the analyte sensor of Fig. 1B.

[0012] Fig. 3A which is a cross-sectional exploded schematic view of a sensing region of a continuous glucose sensor in one embodiment wherein an active enzyme of an enzyme domain is positioned only over the glucose-measuring working electrode.

20 **[0013]** Fig. 3B is a cross-sectional exploded schematic view of a sensing region of a continuous glucose sensor in another embodiment, wherein an active portion of the enzyme within the enzyme domain positioned over the auxiliary working electrode has been deactivated.

[0014] Fig. 4 is a block diagram that illustrates continuous glucose sensor electronics in one embodiment.

[0015] Fig. 5 is a drawing of a receiver for the continuous glucose sensor in one embodiment.

25 **[0016]** Fig. 6 is a block diagram of the receiver electronics in one embodiment.

Detailed Description of the Preferred Embodiment

30 **[0017]** The following description and examples illustrate some exemplary embodiments of the disclosed invention in detail. Those of skill in the art will recognize that there are numerous variations and modifications of this invention that are encompassed by its scope. Accordingly, the description of a certain exemplary embodiment should not be deemed to limit the scope of the present invention.

Definitions

35 **[0018]** In order to facilitate an understanding of the disclosed invention, a number of terms are defined below.

[0019] The term "analyte," as used herein, is a broad term and is used in its ordinary sense, including, but not limited to, to refer to a substance or chemical constituent in a biological fluid (for example, blood, interstitial fluid, cerebral spinal fluid, lymph fluid or urine) that can be analyzed. Analytes may include naturally occurring substances, artificial substances, metabolites, and/or reaction products. In some embodiments, the analyte for measurement by the sensor heads, devices, and methods disclosed herein is glucose. However, other analytes are contemplated as well, including but not limited to acarboxyprothrombin; acylcarnitine; adenine phosphoribosyl transferase; adenosine deaminase; albumin; alpha-fetoprotein; amino acid profiles (arginine (Krebs cycle), histidine/urocanic acid, homocysteine, phenylalanine/tyrosine, tryptophan); adrenostenedione; antipyrine; arabinitol enantiomers; arginase; benzoylecgonine (cocaine); biotinidase; biopterin; c-reactive protein; carnitine; carnosinase; CD4; ceruloplasmin; chenodeoxycholic acid; chloroquine; cholesterol; cholinesterase; conjugated 1- β hydroxy-cholic acid; cortisol; creatine kinase; creatine kinase MM isoenzyme; cyclosporin A; d-penicillamine; deethylchloroquine; dehydroepiandrosterone sulfate; DNA (acetylator polymorphism, alcohol dehydrogenase, alpha 1-antitrypsin, cystic fibrosis, Duchenne/Becker muscular dystrophy, analyte-6-phosphate dehydrogenase, hemoglobinopathies, A,S,C,E, D-Punjab, beta-thalassemia, hepatitis B virus, HCMV, HIV-1, HTLV-1, Leber hereditary optic neuropathy, MCAD, RNA, PKU, Plasmodium vivax, sexual differentiation, 21-deoxycortisol); desbutylhalofantrine; dihydropteridine reductase; diphtheria/tetanus antitoxin; erythrocyte arginase; erythrocyte protoporphyrin; esterase D; fatty acids/acylglycines; free β -human chorionic gonadotropin; free erythrocyte porphyrin; free thyroxine (FT4); free tri-iodothyronine (FT3); fumarylacetoacetase; galactose/gal-1-phosphate; galactose-1-phosphate uridylyltransferase; gentamicin; analyte-6-phosphate dehydrogenase; glutathione; glutathione peroxidase; glycocholic acid; glycosylated hemoglobin; halofantrine; hemoglobin variants; hexosaminidase A; human erythrocyte carbonic anhydrase I ; 17 alpha-hydroxyprogesterone; hypoxanthine phosphoribosyl transferase; immunoreactive trypsin; lactate; lead; lipoproteins ((α), B/A-1, β); lysozyme; mefloquine; netilmicin; phenobarbitone; phenytoin; phytanic/pristanic acid; progesterone; prolactin; prolidase; purine nucleoside phosphorylase; quinine; reverse tri-iodothyronine (rT3); selenium; serum pancreatic lipase; sissomicin; somatomedin C; specific antibodies (adenovirus, anti-nuclear antibody, anti-zeta antibody,

50

55

arbovirus, Aujeszky's disease virus, dengue virus, *Dracunculus medinensis*, *Echinococcus granulosus*, *Entamoeba histolytica*, enterovirus, *Giardia duodenalis*, *Helicobacter pylori*, hepatitis B virus, herpes virus, HIV-1, IgE (atopic disease), influenza virus, *Leishmania donovani*, leptospira, measles/mumps/rubella, *Mycobacterium leprae*, *Mycoplasma pneumoniae*, Myoglobin, *Onchocerca volvulus*, parainfluenza virus, *Plasmodium falciparum*, poliovirus, *Pseudomonas aeruginosa*, respiratory syncytial virus, rickettsia (scrub typhus), *Schistosoma mansoni*, *Toxoplasma gondii*, *Treponema pallidum*, *Trypanosoma cruzi/rangeli*, vesicular stomatis virus, *Wuchereria bancrofti*, yellow fever virus); specific antigens (hepatitis B virus, HIV-1); succinylacetone; sulfadoxine; theophylline; thyrotropin (TSH); thyroxine (T4); thyroxine-binding globulin; trace elements; transferrin; UDP-galactose-4-epimerase; urea; uroporphyrinogen I synthase; vitamin A; white blood cells; and zinc protoporphyrin. Salts, sugar, protein, fat, vitamins and hormones naturally occurring in blood or interstitial fluids may also constitute analytes in certain embodiments. The analyte may be naturally present in the biological fluid, for example, a metabolic product, a hormone, an antigen, an antibody, and the like. Alternatively, the analyte may be introduced into the body, for example, a contrast agent for imaging, a radioisotope, a chemical agent, a fluorocarbon-based synthetic blood, or a drug or pharmaceutical composition, including but not limited to insulin; ethanol; cannabis (marijuana, tetrahydrocannabinol, hashish); inhalants (nitrous oxide, amyl nitrite, butyl nitrite, chloro-hydrocarbons, hydrocarbons); cocaine (crack cocaine); stimulants (amphetamines, methamphetamines, Ritalin, Cylert, Preludin, Didrex, PreState, Voranil, Sandrex, Plegine); depressants (barbituates, methaqualone, tranquilizers such as Valium, Librium, Miltown, Serax, Equanil, Tranxene); hallucinogens (phencyclidine, lysergic acid, mescaline, peyote, psilocybin); narcotics (heroin, codeine, morphine, opium, meperidine, Percocet, Percodan, Tussionex, Fentanyl, Darvon, Talwin, Lomotil); designer drugs (analogs of fentanyl, meperidine, amphetamines, methamphetamines, and phencyclidine, for example, Ecstasy); anabolic steroids; and nicotine. The metabolic products of drugs and pharmaceutical compositions are also contemplated analytes. Analytes such as neurochemicals and other chemicals generated within the body may also be analyzed, such as, for example, ascorbic acid, uric acid, dopamine, noradrenaline, 3-methoxytyramine (3MT), 3,4-Dihydroxyphenylacetic acid (DOPAC), Homovanillic acid (HVA), 5-Hydroxytryptamine (5HT), and 5-Hydroxyindoleacetic acid (FHIAA).

[0020] The term "continuous glucose sensor," as used herein, is a broad term and is used in its ordinary sense, including, but not limited to, a device that continuously or continually measures glucose concentration, for example, at time intervals ranging from fractions of a second up to, for example, 1, 2, or 5 minutes, or longer. It should be understood that continuous glucose sensors can continually measure glucose concentration without requiring user initiation and/or interaction for each measurement, such as described with reference to U.S. Patent 6,001,067, for example.

[0021] The phrase "continuous glucose sensing," as used herein, is a broad term and is used in its ordinary sense, including, but not limited to, the period in which monitoring of plasma glucose concentration is continuously or continually performed, for example, at time intervals ranging from fractions of a second up to, for example, 1, 2, or 5 minutes, or longer.

[0022] The term "biological sample," as used herein, is a broad term and is used in its ordinary sense, including, but not limited to, sample of a host body, for example, blood, interstitial fluid, spinal fluid, saliva, urine, tears, sweat, or the like.

[0023] The term "host," as used herein, is a broad term and is used in its ordinary sense, including, but not limited to, mammals such as humans.

[0024] The term "biointerface membrane," as used herein, is a broad term and is used in its ordinary sense, including, but not limited to, a permeable or semi-permeable membrane that can include two or more domains and is typically constructed of materials of a few microns thickness or more, which can be placed over the sensing region to keep host cells (for example, macrophages) from gaining proximity to, and thereby damaging the membrane system or forming a barrier cell layer and interfering with the transport of glucose across the tissue-device interface.

[0025] The term "membrane system," as used herein, is a broad term and is used in its ordinary sense, including, but not limited to, a permeable or semi-permeable membrane that can be comprised of two or more domains and is typically constructed of materials of a few microns thickness or more, which may be permeable to oxygen and are optionally permeable to glucose. In one example, the membrane system comprises an immobilized glucose oxidase enzyme, which enables an electrochemical reaction to occur to measure a concentration of glucose.

[0026] The term "domain," as used herein is a broad term and is used in its ordinary sense, including, but not limited to, regions of a membrane that can be layers, uniform or nonuniform gradients (for example, anisotropic), functional aspects of a material, or provided as portions of the membrane.

[0027] The term "copolymer," as used herein, is a broad term and is used in its ordinary sense, including, but not limited to, polymers having two or more different repeat units and includes copolymers, terpolymers, tetrapolymers, or the like.

[0028] The term "sensing region," as used herein, is a broad term and is used in its ordinary sense, including, but not limited to, the region of a monitoring device responsible for the detection of a particular analyte. In one embodiment, the sensing region generally comprises a non-conductive body, at least one electrode, a reference electrode and a optionally a counter electrode passing through and secured within the body forming an electrochemically reactive surface at one location on the body and an electronic connection at another location on the body, and a membrane system affixed to the body and covering the electrochemically reactive surface.

[0029] The term "electrochemically reactive surface," as used herein, is a broad term and is used in its ordinary sense, including, but not limited to, the surface of an electrode where an electrochemical reaction takes place. In one embodiment, a working electrode measures hydrogen peroxide creating a measurable electronic current.

5 [0030] The term "electrochemical cell," as used herein, is a broad term and is used in its ordinary sense, including, but not limited to, a device in which chemical energy is converted to electrical energy. Such a cell typically consists of two or more electrodes held apart from each other and in contact with an electrolyte solution. Connection of the electrodes to a source of direct electric current renders one of them negatively charged and the other positively charged. Positive ions in the electrolyte migrate to the negative electrode (cathode) and there combine with one or more electrons, losing part or all of their charge and becoming new ions having lower charge or neutral atoms or molecules; at the same time, 10 negative ions migrate to the positive electrode (anode) and transfer one or more electrons to it, also becoming new ions or neutral particles. The overall effect of the two processes is the transfer of electrons from the negative ions to the positive ions, a chemical reaction.

[0031] The term "enzyme" as used herein, is a broad term and is used in its ordinary sense, including, but not limited to, a protein or protein-based molecule that speeds up a chemical reaction occurring in a living thing. Enzymes may act as catalysts for a single reaction, converting a reactant (also called an analyte herein) into a specific product. In one 15 exemplary embodiment of a glucose oxidase-based glucose sensor, an enzyme, glucose oxidase (GOX) is provided to react with glucose (the analyte) and oxygen to form hydrogen peroxide.

[0032] The term "co-analyte" as used herein, is a broad term and is used in its ordinary sense, including, but not limited to, a molecule required in an enzymatic reaction to react with the analyte and the enzyme to form the specific product being measured. In one exemplary embodiment of a glucose sensor, an enzyme, glucose oxidase (GOX) is provided 20 to react with glucose and oxygen (the co-analyte) to form hydrogen peroxide.

[0033] The term "constant analyte" as used herein, is a broad term and is used in its ordinary sense, including, but not limited to, an analyte that remains relatively constant over a time period, for example over an hour to a day as compared to other variable analytes. For example, in a person with diabetes, oxygen and urea may be relatively constant 25 analytes in particular tissue compartments relative to glucose, which is known to oscillate between about 40 and 400 mg/dL during a 24-hour cycle. Although analytes such as oxygen and urea are known to oscillate to a lesser degree, for example due to physiological processes in a host, they are substantially constant, relative to glucose, and can be digitally filtered, for example low pass filtered, to minimize or eliminate any relatively low amplitude oscillations. Constant analytes other than oxygen and urea are also contemplated.

30 [0034] The term "proximal" as used herein, is a broad term and is used in its ordinary sense, including, but not limited to, near to a point of reference such as an origin or a point of attachment. For example, in some embodiments of a membrane system that covers an electrochemically reactive surface, the electrolyte domain is located more proximal to the electrochemically reactive surface than the resistance domain.

[0035] The term "distal" as used herein, is a broad term and is used in its ordinary sense, including, but not limited to, 35 spaced relatively far from a point of reference, such as an origin or a point of attachment. For example, in some embodiments of a membrane system that covers an electrochemically reactive surface, a resistance domain is located more distal to the electrochemically reactive surfaces than the electrolyte domain.

[0036] The term "substantially" as used herein, is a broad term and is used in its ordinary sense, including, but not limited to, being largely but not necessarily wholly that which is specified.

40 [0037] The term "computer," as used herein, is broad term and is used in its ordinary sense, including, but not limited to, machine that can be programmed to manipulate data.

[0038] The term "modem," as used herein, is a broad term and is used in its ordinary sense, including, but not limited to, an electronic device for converting between serial data from a computer and an audio signal suitable for transmission over a telecommunications connection to another modem.

45 [0039] The terms "processor module" and "microprocessor," as used herein, are broad terms and are used in their ordinary sense, including, but not limited to, a computer system, state machine, processor, or the like designed to perform arithmetic and logic operations using logic circuitry that responds to and processes the basic instructions that drive a computer.

[0040] The term "ROM," as used herein, is a broad term and is used in its ordinary sense, including, but not limited to, 50 read-only memory, which is a type of data storage device manufactured with fixed contents. ROM is broad enough to include EEPROM, for example, which is electrically erasable programmable read-only memory (ROM).

[0041] The term "RAM," as used herein, is a broad term and is used in its ordinary sense, including, but not limited to, a data storage device for which the order of access to different locations does not affect the speed of access. RAM is broad enough to include SRAM, for example, which is static random access memory that retains data bits in its memory 55 as long as power is being supplied.

[0042] The term "A/D Converter," as used herein, is a broad term and is used in its ordinary sense, including, but not limited to, hardware and/or software that converts analog electrical signals into corresponding digital signals.

[0043] The term "RF transceiver," as used herein, is a broad term and is used in its ordinary sense, including, but not

limited to, a radio frequency transmitter and/or receiver for transmitting and/or receiving signals.

5 [0044] The terms "raw data stream" and "data stream," as used herein, are broad terms and are used in their ordinary sense, including, but not limited to, an analog or digital signal directly related to the analyte concentration measured by the analyte sensor. In one example, the raw data stream is digital data in "counts" converted by an A/D converter from an analog signal (for example, voltage or amps) representative of an analyte concentration. The terms broadly encompass a plurality of time spaced data points from a substantially continuous analyte sensor, which comprises individual measurements taken at time intervals ranging from fractions of a second up to, for example, 1, 2, or 5 minutes or longer.

[0045] The term "counts," as used herein, is a broad term and is used in its ordinary sense, including, but not limited to, a unit of measurement of a digital signal. In one example, a raw data stream measured in counts is directly related to a voltage (for example, converted by an A/D converter), which is directly related to current from a working electrode.

10 [0046] The term "electronic circuitry," as used herein, is a broad term and is used in its ordinary sense, including, but not limited to, the components (for example, hardware and/or software) of a device configured to process data. In the case of an analyte sensor, the data includes biological information obtained by a sensor regarding the concentration of the analyte in a biological fluid. U.S. Patent Nos. 4,757,022, 5,497,772 and 4,787,398, describe suitable electronic circuits that can be utilized with devices of certain embodiments.

15 [0047] The term "potentiostat," as used herein, is a broad term and is used in its ordinary sense, including, but not limited to, an electrical system that applies a potential between the working and reference electrodes of a two- or three-electrode cell at a preset value and measures the current flow through the working electrode. The potentiostat forces whatever current is necessary to flow between the working and counter electrodes to keep the desired potential, as long as the needed cell voltage and current do not exceed the compliance limits of the potentiostat.

20 [0048] The terms "operably connected" and "operably linked," as used herein, are broad terms and are used in their ordinary sense, including, but not limited to, one or more components being linked to another component(s) in a manner that allows transmission of signals between the components. For example, one or more electrodes can be used to detect the amount of glucose in a sample and convert that information into a signal; the signal can then be transmitted to an electronic circuit. In this case, the electrode is "operably linked" to the electronic circuit. These terms are broad enough to include wired and wireless connectivity.

25 [0049] The term "smoothing" and "filtering," as used herein, are broad terms and are used in their ordinary sense, including, but not limited to, modification of a set of data to make it smoother and more continuous and remove or diminish outlying points, for example, by performing a moving average of the raw data stream.

30 [0050] The term "algorithn," as used herein, is a broad term and is used in its ordinary sense, including, but not limited to, the computational processes (for example, programs) involved in transforming information from one state to another, for example using computer processing.

[0051] The term "regression," as used herein, is a broad term and is used in its ordinary sense, including, but not limited to, finding a line in which a set of data has a minimal measurement (for example, deviation) from that line. Regression can be linear, non-linear, first order, second order, and so forth. One example of regression is least squares regression.

35 [0052] The term "pulsed amperometric detection," as used herein, is a broad term and is used in its ordinary sense, including, but not limited to, an electrochemical flow cell and a controller, which applies the potentials and monitors current generated by the electrochemical reactions. The cell can include one or multiple working electrodes at different applied potentials. Multiple electrodes can be arranged so that they face the chromatographic flow independently (parallel configuration), or sequentially (series configuration).

40 [0053] The term "calibration," as used herein, is a broad term and is used in its ordinary sense, including, but not limited to, the process of determining the relationship between the sensor data and corresponding reference data, which may be used to convert sensor data into meaningful values substantially equivalent to the reference. In some embodiments, namely in continuous analyte sensors, calibration may be updated or recalibrated over time as changes in the relationship between the sensor and reference data occur, for example due to changes in sensitivity, baseline, transport, metabolism, or the like.

[0054] The term "sensor analyte values" and "sensor data," as used herein, are broad terms and are used in their ordinary sense, including, but not limited to, data received from a continuous analyte sensor, including one or more time-spaced sensor data points.

50 [0055] The term "reference analyte values" and "reference data," as used herein, are broad terms and are used in their ordinary sense, including, but not limited to, data from a reference analyte monitor, such as a blood glucose meter, or the like, including one or more reference data points. In some embodiments, the reference glucose values are obtained from a self-monitored blood glucose (SMBG) test (for example, from a finger or forearm blood test) or a YSI (Yellow Springs Instruments) test, for example.

55 [0056] The term "matched data pairs," as used herein, is a broad term and is used in its ordinary sense, including, but not limited to, reference data (for example, one or more reference analyte data points) matched with substantially time corresponding sensor data (for example, one or more sensor data points).

[0057] The terms "interferants" and "interfering species," as used herein, are broad terms and are used in their ordinary sense, including, but not limited to, effects and/or species that interfere with the measurement of an analyte of interest in a sensor to produce a signal that does not accurately represent the analyte measurement. In one example of an electrochemical sensor, interfering species are compounds with an oxidation potential that overlaps with the analyte to be measured, producing a false positive signal.

Overview

[0058] The preferred embodiments provide a continuous analyte sensor that measures a concentration of the analyte of interest or a substance indicative of the concentration or presence of the analyte. In some embodiments, the analyte sensor is an invasive, minimally invasive, or non-invasive device, for example a subcutaneous, transdermal, or intra-vascular device. In some embodiments, the analyte sensor may analyze a plurality of intermittent biological samples. The analyte sensor may use any method of analyte-measurement, including enzymatic, chemical, physical, electro-chemical, spectrophotometric, polarimetric, calorimetric, radiometric, or the like.

[0059] In general, analyte sensors provide at least one working electrode and at least one reference electrode, which are configured to measure a signal associated with a concentration of the analyte in the host, such as described in more detail below, and as appreciated by one skilled in the art. The output signal is typically a raw data stream that is used to provide a useful value of the measured analyte concentration in a host to the patient or doctor, for example. However, the analyte sensors of the preferred embodiments may further measure at least one additional signal associated with the baseline and/or sensitivity of the analyte sensor, thereby enabling monitoring of baseline and/or sensitivity changes that may occur in a continuous analyte sensor over time.

[0060] In general, continuous analyte sensors define a relationship between sensor-generated measurements (for example, current in nA or digital counts after A/D conversion) and a reference measurement (for example, mg/dL or mmol/L) that are meaningful to a user (for example, patient or doctor). In the case of an implantable enzyme-based electrochemical glucose sensors, the sensing mechanism generally depends on phenomena that are linear with glucose concentration, for example: (1) diffusion of glucose through a membrane system (for example, biointerface membrane and membrane system) situated between implantation site and the electrode surface, (2) an enzymatic reaction within the membrane system (for example, membrane system), and (3) diffusion of the H₂O₂ to the sensor. Because of this linearity, calibration of the sensor can be understood by solving an equation:

$$y = mx + b$$

where y represents the sensor signal (counts), x represents the estimated glucose concentration (mg/dL), m represents the sensor sensitivity to glucose (counts/mg/dL), and b represents the baseline signal (counts). Because both sensitivity m and baseline b change over time *in vivo*, calibration has conventionally required at least two independent, matched data pairs ($x_1, y_1; x_2, y_2$) to solve for m and b and thus allow glucose estimation when only the sensor signal, y is available. Matched data pairs can be created by matching reference data (for example, one or more reference glucose data points from a blood glucose meter, or the like) with substantially time corresponding sensor data (for example, one or more glucose sensor data points) to provide one or more matched data pairs, such as described in co-pending U.S. Patent Appl. No. 10/633,367.

[0061] Accordingly, in some embodiments, the sensing region is configured to measure changes in sensitivity of the analyte sensor over time, which can be used to trigger calibration, update calibration, avoid inaccurate calibration (for example, calibration during unstable periods), and/or trigger filtering of the sensor data. Namely, the analyte sensor is configured to measure a signal associated with a non-analyte constant in the host. Preferably, the non-analyte constant signal is measured beneath the membrane system on the sensor. In one example of a glucose sensor, a non-glucose constant that can be measured is oxygen, wherein a measured change in oxygen transport is indicative of a change in the sensitivity of the glucose signal, which can be measured by switching the bias potential of the working electrode, an auxiliary oxygen-measuring electrode, an oxygen sensor, or the like, as described in more detail elsewhere herein.

[0062] Alternatively or additionally, in some embodiments, the sensing region is configured to measure changes in the amount of background noise (baseline) in the signal, which can be used to trigger calibration, update calibration, avoid inaccurate calibration (for example, calibration during unstable periods), and/or trigger filtering of the sensor data. In one example of a glucose sensor, the baseline is composed substantially of signal contribution due to factors other than glucose (for example, interfering species, non-reaction-related hydrogen peroxide, or other electroactive species with an oxidation potential that overlaps with hydrogen peroxide). Namely, the glucose sensor is configured to measure a signal associated with the baseline (all non-glucose related current generated) measured by sensor in the host. In some embodiments, an auxiliary electrode located beneath a non-enzymatic portion of the membrane system is used

to measure the baseline signal. In some embodiments, the baseline signal is subtracted from the glucose signal (which includes the baseline) to obtain the signal contribution substantially only due to glucose. Subtraction may be accomplished electronically in the sensor using a differential amplifier, digitally in the receiver, and/or otherwise in the hardware or software of the sensor or receiver as is appreciated by one skilled in the art, and as described in more detail elsewhere herein.

[0063] One skilled in the art appreciates that the above-described sensitivity and baseline signal measurements can be combined to benefit from both measurements in a single analyte sensor.

Exemplary Continuous Glucose Sensor Configurations

[0064] Although two exemplary glucose sensor configurations are described in detail below, it should be understood that the systems and methods described herein can be applied to any device capable of continually or continuously detecting a concentration of analyte of interest and providing an output signal that represents the concentration of that analyte, for example oxygen, lactose, hormones, cholesterol, medicaments, viruses, or the like.

[0065] Fig. 1A is a perspective view of an analyte sensor, including an implantable body with a sensing region including a membrane system disposed thereon. In the illustrated embodiment, the analyte sensor 10a includes a body 12 and a sensing region 14 including membrane and electrode systems configured to measure the analyte. In this embodiment, the sensor 10a is preferably wholly implanted into the subcutaneous tissue of a host, such as described in US 2006/015020 and U.S. Patent Number 6,001,067 issued December 14, 1999 and entitled "DEVICE AND METHOD FOR DETERMINING ANALYTE LEVELS".

[0066] The body 12 of the sensor 10a can be formed from a variety of materials, including metals, ceramics, plastics, or composites thereof. In one embodiment, the sensor is formed from thermoset molded around the sensor electronics. Co-pending US 2006/015020 discloses suitable configurations for the body.

[0067] In some embodiments, the sensing region 14 includes a glucose-measuring working electrode 16, an auxiliary working electrode 18, a reference electrode 20, and a counter electrode 22. Generally, the sensing region 14 includes means to measure two different signals, 1) a first signal associated with glucose and non-glucose related electroactive compound having a first oxidation potential, wherein the first signal is measured at the glucose-measuring working electrode disposed beneath an active enzymatic portion of a membrane system, and 2) a second signal associated with the baseline and/or sensitivity of the glucose sensor. In some embodiments, wherein the second signal measures sensitivity, the signal is associated with at least one non-glucose constant data point, for example, wherein the auxiliary working electrode 18 is configured to measure oxygen. In some embodiments, wherein the second signal measures baseline, the signal is associated with at non-glucose related electroactive compounds having the first oxidation potential, wherein the second signal is measured at an auxiliary working electrode 18 and is disposed beneath a non-enzymatic portion of the membrane system, such as described in more detail elsewhere herein.

[0068] Preferably, a membrane system (see Fig. 2A) is deposited over the electroactive surfaces of the sensor 10a and includes a plurality of domains or layers, such as described in more detail below, with reference to Figs. 2A and 2B. In general, the membrane system may be disposed over (deposited on) the electroactive surfaces using methods appreciated by one skilled in the art. See US 2006/015020.

[0069] The sensing region 14 comprises electroactive surfaces, which are in contact with an electrolyte phase (not shown), which is a free-flowing fluid phase disposed between the membrane system 22 and the electroactive surfaces. In this embodiment, the counter electrode is provided to balance the current generated by the species being measured at the working electrode. In the case of glucose oxidase based analyte sensors, the species being measured at the working electrode is H_2O_2 . Glucose oxidase catalyzes the conversion of oxygen and glucose to hydrogen peroxide and gluconate according to the following reaction:

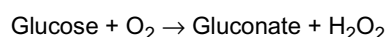

[0070] The change in H_2O_2 can be monitored to determine glucose concentration because for each glucose molecule metabolized, there is a proportional change in the product H_2O_2 . Oxidation of H_2O_2 by the working electrode is balanced by reduction of ambient oxygen, enzyme generated H_2O_2 , or other reducible species at the counter electrode. The H_2O_2 produced from the glucose oxidase reaction further reacts at the surface of the working electrode and produces two protons ($2H^+$), two electrons ($2e^-$), and one oxygen molecule (O_2). Preferably, one or more potentiostat is employed to monitor the electrochemical reaction at the electroactive surface of the working electrode(s). The potentiostat applies a constant potential to the working electrode and its associated reference electrode to determine the current produced at the working electrode. The current that is produced at the working electrode (and flows through the circuitry to the counter electrode) is substantially proportional to the amount of H_2O_2 that diffuses to the working electrodes. The output signal is typically a raw data stream that is used to provide a useful value of the measured analyte concentration in a host to the patient or doctor, for example.

[0071] Fig. 1B is an expanded view of an alternative exemplary embodiment of a continuous analyte sensor 10b, also referred to as a transcutaneous analyte sensor, particularly illustrating the *in vivo* portion of the sensor. In this embodiment, the *in vivo* portion of the sensor 10b is the portion adapted for insertion under the host's skin, while an *ex vivo* portion of the sensor (not shown) is the portion that remains above the host's skin after sensor insertion and operably connects to an electronics unit. In the illustrated embodiment, the analyte sensor 10b, includes three electrodes: a glucose-measuring working electrode 16, an optional auxiliary working electrode 18, and at least one additional electrode 20, which may function as a counter and/or reference electrode, hereinafter referred to as the reference electrode 20. Generally, the sensor 10b may include the ability to measure two different signals, 1) a first signal associated with glucose and non-glucose related electroactive compounds having a first oxidation potential, wherein the first signal is measured at the glucose-measuring working electrode disposed beneath an active enzymatic portion of a membrane system, and 2) a second signal associated with the baseline and/or sensitivity of the glucose sensor, such as described in more detail above with reference to Fig. 1A.

[0072] Preferably, each electrode is formed from a fine wire, with a diameter in the range of 0.001 to 0.010 inches (0.025 to 0.25 mm), for example, and may be formed from plated wire or bulk material, however the electrodes may be deposited on a substrate or other known configurations as is appreciated by one skilled in the art.

[0073] In one embodiment, the glucose-measuring working electrode 16 comprises a wire formed from a conductive material, such as platinum, palladium, graphite, gold, carbon, conductive polymer, or the like. The glucose-measuring working electrode 16 is configured and arranged to measure the concentration of glucose. The glucose-measuring working electrode 16 is covered with an insulating material, for example a non-conductive polymer. Dip-coating, spray-coating, or other coating or deposition techniques can be used to deposit the insulating material on the working electrode, for example. In one preferred embodiment, the insulating material comprises Parylene, which can be an advantageous conformal coating for its strength, lubricity, and electrical insulation properties, however, a variety of other insulating materials can be used, for example, fluorinated polymers, polyethyleneterephthalate, polyurethane, polyimide, or the like.

[0074] In this embodiment, the auxiliary working electrode 18 comprises a wire formed from a conductive material, such as described with reference to the glucose-measuring working electrode 16 above. Preferably, the reference electrode 20, which may function as a reference electrode alone, or as a dual reference and counter electrode, is formed from silver, Silver/Silver chloride, or the like.

[0075] The electrodes are juxtapositioned and/or twisted with or around each other. In one example, the auxiliary working electrode 18 and reference electrode 20 may be helically wound around the glucose-measuring working electrode 16 as illustrated in Fig. 1B. Alternatively, the auxiliary working electrode 18 and reference electrode 20 may be formed as a double helix around a length of the glucose-measuring working electrode 16 (not shown). The assembly of wires may then be optionally coated together with an insulating material, similar to that described above, in order to provide an insulating attachment. Some portion of the coated assembly structure is then stripped, for example using an excimer laser, chemical etching, or the like, to expose the necessary electroactive surfaces. In some alternative embodiments, additional electrodes may be included within the assembly, for example, a three-electrode system (including separate reference and counter electrodes) as is appreciated by one skilled in the art.

[0076] Preferably, a membrane system (see Fig. 2B) is deposited over the electroactive surfaces of the sensor 10b and includes a plurality of domains or layers, such as described in more detail below, with reference to Figs. 2A and 2B. The membrane system may be deposited on the exposed electroactive surfaces using known thin film techniques (for example, spraying, electro-depositing, dipping, or the like). In one exemplary embodiment, each domain is deposited by dipping the sensor into a solution and drawing out the sensor at a speed that provides the appropriate domain thickness. In general, the membrane system may be disposed over (deposited on) the electroactive surfaces using methods appreciated by one skilled in the art.

[0077] In the illustrated embodiment, the sensor is an enzyme-based electrochemical sensor, wherein the glucose-measuring working electrode 16 measures the hydrogen peroxide produced by the enzyme catalyzed reaction of glucose being detected and creates a measurable electronic current (for example, detection of glucose utilizing glucose oxidase produces H_2O_2 peroxide as a by product, H_2O_2 reacts with the surface of the working electrode producing two protons ($2H^+$), two electrons ($2e^-$) and one molecule of oxygen (O_2) which produces the electronic current being detected), such as described in more detail above and as is appreciated by one skilled in the art. Preferably, one or more potentiostat is employed to monitor the electrochemical reaction at the electroactive surface of the working electrode(s). The potentiostat applies a constant potential to the working electrode and its associated reference electrode to determine the current produced at the working electrode. The current that is produced at the working electrode (and flows through the circuitry to the counter electrode) is substantially proportional to the amount of H_2O_2 that diffuses to the working electrodes. The output signal is typically a raw data stream that is used to provide a useful value of the measured analyte concentration in a host to the patient or doctor, for example.

[0078] Some alternative analyte sensors that can benefit from the systems and methods of the preferred embodiments include U.S. Patent No. 5,711,861 to Ward et al., U.S. Patent No. 6,642,015 to Vachon et al., U.S. Patent No. 6,654,625 to Say et al., U.S. Patent 6,565,509 to Say et al., U.S. Patent No. 6,514,718 to Heller, U.S. Patent No. 6,465,066 to

Essenpreis et al., U.S. Patent No. 6,214,185 to Offenbacher et al., U.S. Patent No. 5,310,469 to Cunningham et al., and U.S. Patent No. 5,683,562 to Shaffer et al., U.S. Patent 6,579,690 to Bonnacaze et al., U.S. Patent 6,484,046 to Say et al., U.S. Patent 6,512,939 to Colvin et al., U.S. Patent 6,424,847 to Mastrototaro et al., U.S. Patent 6,424,847 to Mastrototaro et al, for example. In general, it should be understood that the disclosed embodiments are applicable to a variety of analyte sensor configurations.

Membrane System

[0079] In general, analyte sensors include a membrane system that functions to control the flux of a biological fluid therethrough and/or to protect sensitive regions of the sensor from contamination by the biological fluid, for example. Some conventional electrochemical enzyme-based analyte sensors generally include a membrane system that controls the flux of the analyte being measured, protects the electrodes from contamination of the biological fluid, and/or provides an enzyme that catalyzes the reaction of the analyte with a co-factor, for example. See, e.g., US 2006/015020.

[0080] The membrane system 22 can include any membrane configuration suitable for use with any analyte sensor (such as described with reference to Figs. 1A and 1B). In the illustrated embodiments, the membrane system 22 includes a plurality of domains, all or some of which can be adhered to the analyte sensor 10 as is appreciated by one skilled in the art. In one embodiment, the membrane system generally provides one or more of the following functions: 1) protection of the exposed electrode surface from the biological environment, 2) diffusion resistance (limitation) of the analyte, 3) a catalyst for enabling an enzymatic reaction, 4) limitation or blocking of interfering species, and 5) hydrophilicity at the electrochemically reactive surfaces of the sensor interface, such as described in US 2006/015020.

Accordingly, the membrane system 22 preferably includes a plurality of domains or layers, for example, resistance domain 30, an interference domain 28, an enzyme domain 26 (for example, glucose oxidase), an electrolyte domain 24, and may additionally include a cell disruptive domain, a cell impermeable domain, and/or an oxygen domain (not shown), such as described in more detail in the above-cited US 2006/015020. However, it is understood that a membrane system modified for other sensors, for example, by including fewer or additional domains is within the scope of the preferred embodiments.

[0081] In some embodiments, the domains of the biointerface and membrane systems are formed from materials such as silicone, polytetrafluoroethylene, polyethylene-co-tetrafluoroethylene, polyolefin, polyester, polycarbonate, biostable polytetrafluoroethylene, homopolymers, copolymers, terpolymers of polyurethanes, polypropylene (PP), polyvinylchloride (PVC), polyvinylidene fluoride (PVDF), polybutylene terephthalate (PBT), polymethylmethacrylate (PMMA), polyether ether ketone (PEEK), polyurethanes, cellulosic polymers, polysulfones and block copolymers thereof including, for example, di-block, tri-block, alternating, random and graft copolymers. Co-pending U.S. Patent Application 10/838,912, which is incorporated herein by reference in its entirety, describes biointerface and membrane system configurations and materials that may be applied to the preferred embodiments.

[0082] Figs. 2A and 2B are schematic views membrane systems in some embodiments that may be disposed over the electroactive surfaces of an analyte sensors of Fig. 1A and 1B, respectively, wherein the membrane system includes one or more of the following domains: a resistance domain 30, an enzyme domain 28, an interference domain 26, and an electrolyte domain 24, such as described in more detail below. However, it is understood that the membrane system 22 can be modified for use in other sensors, by including only one or more of the domains, additional domains not recited above, or for other sensor configurations. For example, the interference domain can be removed when other methods for removing interferants are utilized, such as an auxiliary electrode for measuring and subtracting out signal due to interferants. As another example, an "oxygen antenna domain" composed of a material that has higher oxygen solubility than aqueous media so that it concentrates oxygen from the biological fluid surrounding the biointerface membrane can be added. The oxygen antenna domain can then act as an oxygen source during times of minimal oxygen availability and has the capacity to provide on demand a higher rate of oxygen delivery to facilitate oxygen transport to the membrane. This enhances function in the enzyme reaction domain and at the counter electrode surface when glucose conversion to hydrogen peroxide in the enzyme domain consumes oxygen from the surrounding domains. Thus, this ability of the oxygen antenna domain to apply a higher flux of oxygen to critical domains when needed improves overall sensor function.

Electrolyte domain

[0083] In some preferred embodiments, an electrolyte domain 24 is provided to ensure an electrochemical reaction occurs at the electroactive surfaces. Preferably, the electrolyte domain includes a semipermeable coating that maintains hydrophilicity at the electrochemically reactive surfaces of the sensor interface. The electrolyte domain enhances the stability of the interference domain 26 by protecting and supporting the material that makes up the interference domain. The electrolyte domain also assists in stabilizing the operation of the sensor by overcoming electrode start-up problems and drifting problems caused by inadequate electrolyte. The buffered electrolyte solution contained in the electrolyte domain also protects against pH-mediated damage that can result from the formation of a large pH gradient between

the substantially hydrophobic interference domain and the electrodes due to the electrochemical activity of the electrodes. In one embodiment, the electrolyte domain 24 includes a flexible, water-swellaable, substantially solid gel-like film.

Interference domain

5 [0084] Interferants are molecules or other species that are electro-reduced or electro-oxidized at the electrochemically reactive surfaces, either directly or via an electron transfer agent, to produce a false signal. In one embodiment, the interference domain 26 prevents the penetration of one or more interferants (for example, ureate, ascorbate, or aceta-
10 minophen) into the electrolyte phase around the electrochemically reactive surfaces. Preferably, this type of interference domain is much less permeable to one or more of the interferants than to the analyte.

[0085] In one embodiment, the interference domain 26 can include ionic components incorporated into a polymeric matrix to reduce the permeability of the interference domain to ionic interferants having the same charge as the ionic components. In another embodiment, the interference domain 26 includes a catalyst (for example, peroxidase) for catalyzing a reaction that removes interferants. U.S. Patent 6,413,396 and U.S. Patent 6,565,509 disclose methods and materials for eliminating interfering species. However, in the preferred embodiments any suitable method or material can be employed.

15 [0086] In one embodiment, the interference domain 26 includes a thin membrane that is designed to limit diffusion of species, e.g., those greater than 34 g/mol in molecular weight, for example. The interference domain permits analytes and other substances (for example, hydrogen peroxide) that are to be measured by the electrodes to pass through, while preventing passage of other substances, such as potentially interfering substances. In one embodiment, the interference domain 26 is constructed of polyurethane.

Enzyme domain

25 [0087] In the preferred embodiments, the enzyme domain 28 provides a catalyst to catalyze the reaction of the analyte and its co-reactant, as described in greater detail above. In preferred embodiments, the enzyme domain includes glucose oxidase. However other oxidases, for example, galactose oxidase or uricase, can be used.

[0088] For example, enzyme-based electrochemical analyte sensor performance at least partially depends on a response that is neither limited by enzyme activity nor cofactor concentration. Because enzymes, including glucose oxidase, are subject to deactivation as a function of ambient conditions, this behavior needs to be accounted for in constructing analyte sensors. Preferably, the domain is constructed of aqueous dispersions of colloidal polyurethane polymers including the enzyme. However, some alternative embodiments construct the enzyme domain from an oxygen antenna material, for example, silicone or fluorocarbons, in order to provide a supply of excess oxygen during transient ischemia. Preferably, the enzyme is immobilized within the domain, as is appreciated by one skilled in the art.

Resistance domain

35 [0089] The resistance domain 30 includes a semipermeable membrane that controls the flux of analytes of interest (for example, glucose and oxygen) to the underlying enzyme domain 28. As a result, the upper limit of linearity of an analyte measurement can be extended to a much higher value than what can be achieved without the resistance domain. In one embodiment of a glucose sensor, the resistance domain 38 exhibits an oxygen-to-glucose permeability ratio of approximately 200:1. As a result, one-dimensional reactant diffusion is adequate to provide excess oxygen at all reasonable glucose and oxygen concentrations found in the subcutaneous matrix (See Rhodes et al., Anal. Chem., 66: 1520-1529 (1994)).

40 [0090] In some alternative embodiments, a lower ratio of oxygen-to-glucose can be sufficient to provide excess oxygen by using an oxygen antenna domain (for example, a silicone or fluorocarbon based material or domain) to enhance the supply/transport of oxygen to the enzyme domain. In other words, if more oxygen is supplied to the enzyme, then more glucose can also be supplied to the enzyme without the rate of this reaction being limited by a lack of glucose. In some alternative embodiments, the resistance domain is formed from a silicone composition, such as described in US 2006/015020.

45 [0091] In one preferred embodiment, the resistance layer includes a homogenous polyurethane membrane with both hydrophilic and hydrophobic regions to control the diffusion of glucose and oxygen to an analyte sensor, the membrane being fabricated easily and reproducibly from commercially available materials. In preferred embodiments, the thickness of the resistance domain is from about 10 microns or less to about 200 microns or more.

50 [0092] The above-described domains are exemplary and are not meant to be limiting to the following description, for example, their systems and methods are designed for the exemplary enzyme-based electrochemical sensor embodiment.

Membrane Configurations

[0093] Figs. 3A to 3B are cross-sectional exploded schematic views of the sensing region of a glucose sensor 10, which show architectures of the membrane system 22 disposed over electroactive surfaces of glucose sensors in some embodiments. In the illustrated embodiments of Figs. 3A and 3B, the membrane system 22 is positioned at least over the glucose-measuring working electrode 16 and the optional auxiliary working electrode 18, however the membrane system may be positioned over the reference and/or counter electrodes 20,22 in some embodiments.

[0094] Reference is now made to Fig. 3A, which is a cross-sectional exploded schematic view of the sensing region in one embodiment wherein an active enzyme 32 of the enzyme domain is positioned only over the glucose-measuring working electrode 16. In this embodiment, the membrane system is formed such that the glucose oxidase 32 only exists above the glucose-measuring working electrode 16. In one embodiment, during the preparation of the membrane system 22, the enzyme domain coating solution can be applied as a circular region similar to the diameter of the glucose-measuring working electrode 16. This fabrication can be accomplished in a variety of ways such as screen-printing or pad printing. Preferably, the enzyme domain is pad printed during the enzyme domain fabrication with equipment as available from Pad Print Machinery of Vermont (Manchester, VT). This embodiment provides the active enzyme 32 above the glucose-measuring working electrode 16 only, so that the glucose-measuring working electrode 16 (and not the auxiliary working electrode 18) measures glucose concentration. Additionally, this embodiment provides an added advantage of eliminating the consumption of O₂ above the counter electrode (if applicable) by the oxidation of glucose with glucose oxidase.

[0095] Fig. 3B is a cross-sectional exploded schematic view of a sensing region of the preferred embodiments, and wherein the portion of the active enzyme within the membrane system 22 positioned over the auxiliary working electrode 18 has been deactivated 34. In one alternative embodiment, the enzyme of the membrane system 22 may be deactivated 34 everywhere except for the area covering the glucose-measuring working electrode 16 or may be selectively deactivated only over certain areas (for example, auxiliary working electrode 18, counter electrode 22, and/or reference electrode 20) by irradiation, or the like. In such a case, a mask (for example, such as those used for photolithography) can be placed above the membrane that covers the glucose-measuring working electrode 16. In this way, exposure of the masked membrane to ultraviolet light deactivates the glucose oxidase in all regions except that covered by the mask.

[0096] In some alternative embodiments, the membrane system is disposed on the surface of the electrode(s) using known deposition techniques. The electrode-exposed surfaces can be inseted within the sensor body, planar with the sensor body, or extending from the sensor body. Although some examples of membrane systems have been provided above, the concepts described herein can be applied to numerous known architectures not described herein.

Sensor Electronics

[0097] In some embodiments, the sensing region may include reference and/or electrodes associated with the glucose-measuring working electrode and separate reference and/or counter electrodes associated with the auxiliary working electrode(s). In yet another embodiment, the sensing region may include a glucose-measuring working electrode, an auxiliary working electrode, two counter electrodes (one for each working electrode), and one shared reference electrode. In yet another embodiment, the sensing region may include a glucose-measuring working electrode, an auxiliary working electrode, two reference electrodes, and one shared counter electrode. However, a variety of electrode materials and configurations can be used with the implantable analyte sensor of the preferred embodiments.

[0098] In some alternative embodiments, the working electrodes are interdigitated. In some alternative embodiments, the working electrodes each comprise multiple exposed electrode surfaces; one advantage of these architectures is to distribute the measurements across a greater surface area to overcome localized problems that may occur *in vivo*, for example, with the host's immune response at the biointerface. Preferably, the glucose-measuring and auxiliary working electrodes are provided within the same local environment, such as described in more detail elsewhere herein.

[0099] Fig. 4 is a block diagram that illustrates the continuous glucose sensor electronics in one embodiment. In this embodiment, a first potentiostat 36 is provided that is operatively associated with the glucose-measuring working electrode 16. The first potentiostat 36 measures a current value at the glucose-measuring working electrode and preferably includes a resistor (not shown) that translates the current into voltage. An optional second potentiostat 37 is provided that is operatively associated with the auxiliary working electrode 18. The second potentiostat 37 measures a current value at the auxiliary working electrode 18 and preferably includes a resistor (not shown) that translates the current into voltage. It is noted that in some embodiments, the auxiliary electrode can be configured to share the first potentiostat with the glucose-measuring working electrode. An A/D converter 38 digitizes the analog signals from the potentiostats 36, 37 into counts for processing. Accordingly, resulting raw data streams (in counts) can be provided that are directly related to the current measured by each of the potentiostats 36 and 37.

[0100] A microprocessor 40, also referred to as the processor module, is the central control unit that houses EEPROM 42 and SRAM 44, and controls the processing of the sensor electronics. It is noted that certain alternative embodiments

can utilize a computer system other than a microprocessor to process data as described herein. In other alternative embodiments, an application-specific integrated circuit (ASIC) can be used for some or all the sensor's central processing. The EEPROM 42 provides semi-permanent storage of data, for example, storing data such as sensor identifier (ID) and programming to process data streams (for example, such as described in copending U.S. Patent Application Serial

5 Number 10/633,367.
The SRAM 44 can be used for the system's cache memory, for example for temporarily storing recent sensor data. In some alternative embodiments, memory storage components comparable to EEPROM and SRAM may be used instead of or in addition to the preferred hardware, such as dynamic RAM, non-static RAM, rewritable ROMs, flash memory, or the like.

10 **[0101]** A battery 46 is operably connected to the microprocessor 40 and provides the necessary power for the sensor 10a. In one embodiment, the battery is a Lithium Manganese Dioxide battery, however any appropriately sized and powered battery can be used (for example, AAA, Nickel-cadmium, Zinc-carbon, Alkaline, Lithium, Nickel-metal hydride, Lithium-ion, Zinc-air, Zinc-mercury oxide, Silver-zinc, and/or hermetically-sealed). In some embodiments the battery is rechargeable. In some embodiments, a plurality of batteries can be used to power the system. In some embodiments,
15 one or more capacitors can be used to power the system. A Quartz Crystal 48 may be operably connected to the microprocessor 40 to maintain system time for the computer system as a whole.

[0102] An RF Transceiver 50 may be operably connected to the microprocessor 40 to transmit the sensor data from the sensor 10 to a receiver (see Figs. 4 and 5) within a wireless transmission 52 via antenna 54. Although an RF transceiver is shown here, some other embodiments can include a wired rather than wireless connection to the receiver.
20 In yet other embodiments, the receiver can be transcutaneously powered via an inductive coupling, for example. A second quartz crystal 56 can provide the system time for synchronizing the data transmissions from the RF transceiver. It is noted that the transceiver 50 can be substituted with a transmitter in other embodiments. In some alternative embodiments other mechanisms such as optical, infrared radiation (IR), ultrasonic, or the like may be used to transmit and/or receive data.

25
Receiver

[0103] Fig. 5 is a schematic drawing of a receiver for the continuous glucose sensor in one embodiment. The receiver 58 comprises systems necessary to receive, process, and display sensor data from the analyte sensor, such as described
30 in more detail elsewhere herein. Particularly, the receiver 58 may be a pager-sized device, for example, and house a user interface that has a plurality of buttons and/or keypad and a liquid crystal display (LCD) screen, and which may include a backlight. In some embodiments the user interface may also include a speaker, and a vibrator such as described with reference to Fig. 6.

[0104] Fig. 6 is a block diagram of the receiver electronics in one embodiment. In some embodiments, the receiver comprises a configuration such as described with reference to Fig. 5, above. However, the receiver may comprise any reasonable configuration, including a desktop computer, laptop computer, a personal digital assistant (PDA), a server (local or remote to the receiver), or the like. In some embodiments, a receiver may be adapted to connect (via wired or wireless connection) to a desktop computer, laptop computer, a PDA, a server (local or remote to the receiver), or the like in order to download data from the receiver. In some alternative embodiments, the receiver may be housed within
40 or directly connected to the sensor in a manner that allows sensor and receiver electronics to work directly together and/or share data processing resources. Accordingly, the receiver, including its electronics, may be generally described as a "computer system."

[0105] A quartz crystal 60 may be operably connected to an RF transceiver 62 that together function to receive and synchronize data streams via an antenna 64 (for example, transmission 52 from the RF transceiver 50 shown in Fig. 4).
45 Once received, a microprocessor 66 can process the signals, such as described below.

[0106] The microprocessor 66, also referred to as the processor module, is the central control unit that provides the processing, such as storing data, calibrating sensor data, downloading data, controlling the user interface by providing prompts, messages, warnings and alarms, or the like. The EEPROM 68 may be operably connected to the microprocessor 66 and provides semi-permanent storage of data, storing data such as receiver ID and programming to process data
50 streams (for example, programming for performing calibration and other algorithms described elsewhere herein). SRAM 70 may be used for the system's cache memory and is helpful in data processing. For example, the SRAM stores information from the continuous glucose sensor for later recall by the patient or a doctor; a patient or doctor can transcribe the stored information at a later time to determine compliance with the medical regimen or a comparison of glucose concentration to medication administration (for example, this can be accomplished by downloading the information through the pc com port 76). In addition, the SRAM 70 can also store updated program instructions and/or patient specific information. In some alternative embodiments, memory storage components comparable to EEPROM and SRAM can be used instead of or in addition to the preferred hardware, such as dynamic RAM, non-static RAM, rewritable ROMs,
55 flash memory, or the like.

[0107] A battery 72 may be operably connected to the microprocessor 66 and provides power for the receiver. In one embodiment, the battery is a standard AAA alkaline battery, however any appropriately sized and powered battery can be used. In some embodiments, a plurality of batteries can be used to power the system. In some embodiments, a power port (not shown) is provided permit recharging of rechargeable batteries. A quartz crystal 84 may be operably connected

5 to the microprocessor 66 and maintains system time for the system as a whole.
[0108] A PC communication (com) port 76 can be provided to enable communication with systems, for example, a serial communications port, allows for communicating with another computer system (for example, PC, PDA, server, or the like). In one exemplary embodiment, the receiver is able to download historical data to a physician's PC for retrospective analysis by the physician. The PC communication port 76 can also be used to interface with other medical

10 devices, for example pacemakers, implanted analyte sensor patches, infusion devices, telemetry devices, or the like.
[0109] A user interface 78 comprises a keypad 80, speaker 82, vibrator 84, backlight 86, liquid crystal display (LCD) 88, and one or more buttons 90. The components that comprise the user interface 78 provide controls to interact with the user. The keypad 80 can allow, for example, input of user information about himself/herself, such as mealtime, exercise, insulin administration, and reference glucose values. The speaker 82 can provide, for example, audible signals or alerts for conditions such as present and/or predicted hyper- and hypoglycemic conditions. The vibrator 84 can provide, for example, tactile signals or alerts for reasons such as described with reference to the speaker, above. The backlight 94 can be provided, for example, to aid the user in reading the LCD in low light conditions. The LCD 88 can be provided, for example, to provide the user with visual data output. In some embodiments, the LCD is a touch-activated screen. The buttons 90 can provide for toggle, menu selection, option selection, mode selection, and reset, for example. In some

20 alternative embodiments, a microphone can be provided to allow for voice-activated control.
[0110] The user interface 78, which is operably connected to the microprocessor 70 serves to provide data input and output for the continuous analyte sensor. In some embodiments, prompts can be displayed to inform the user about necessary maintenance procedures, such as "Calibrate Sensor" or "Replace Battery." In some embodiments, prompts or messages can be displayed on the user interface to convey information to the user, such as malfunction, outlier values, missed data transmissions, or the like. Additionally, prompts can be displayed to guide the user through calibration of the continuous glucose sensor, for example when to obtain a reference glucose value.

25 **[0111]** Keypad, buttons, touch-screen, and microphone are all examples of mechanisms by which a user can input data directly into the receiver. A server, personal computer, personal digital assistant, insulin pump, and insulin pen are examples of external devices that can be connected to the receiver via PC com port 76 to provide useful information to the receiver. Other devices internal or external to the sensor that measure other aspects of a patient's body (for example, temperature sensor, accelerometer, heart rate monitor, oxygen monitor, or the like) can be used to provide input helpful in data processing. In one embodiment, the user interface can prompt the patient to select an activity most closely related to their present activity, which can be helpful in linking to an individual's physiological patterns, or other data processing. In another embodiment, a temperature sensor and/or heart rate monitor can provide information helpful in linking activity, metabolism, and glucose excursions of an individual. While a few examples of data input have been provided here, a variety of information can be input and can be helpful in data processing as will be understood by one skilled in the art.

Calibration Systems and Methods

40 **[0112]** As described above in the Overview Section, continuous analyte sensors define a relationship between sensor-generated measurements and a reference measurement that is meaningful to a user (for example, blood glucose in mg/dL). This defined relationship must be monitored to ensure that the continuous analyte sensor maintains a substantially accurate calibration and thereby continually provides meaningful values to a user. Unfortunately, both sensitivity m and baseline b of the calibration are subject to changes that occur *in vivo* over time (for example, hours to months), requiring updates to the calibration. Generally, any physical property that influences diffusion or transport of molecules through the membrane can alter the sensitivity (and/or baseline) of the calibration. Physical properties that can alter the transport of molecules include, but are not limited to, blockage of surface area due to foreign body giant cells and other barrier cells at the biointerface, distance of capillaries from the membrane, foreign body response/capsule, disease, tissue ingrowth, thickness of membrane system, or the like.

50 **[0113]** In one example of a change in transport of molecules, an implantable glucose sensor is implanted in the subcutaneous space of a human, which is at least partially covered with a biointerface membrane, such as described in US2006/015020.

Although the body's natural response to a foreign object is to encapsulate the sensor, the architecture of this biointerface membrane encourages tissue ingrowth and neo-vascularization over time, providing transport of solutes (for example, glucose and oxygen) close to the membrane that covers the electrodes. While not wishing to be bound by theory, it is believed that ingrowth of vascularized tissue matures (changes) over time, beginning with a short period of high solute transport during the first few days after implantation, continuing through a time period of significant tissue ingrowth a few days to a week or more after implantation during which low solute transport to the membrane has been observed,

and into a mature state of vascularized tissue during which the bed of vascularized tissue provides moderate to high solute transport, which can last for months and even longer after implantation. In some embodiments, this maturation process accounts for a substantial portion of the change in sensitivity and/or baseline of the calibration over time due to changes in solute transport to the membrane.

5 **[0114]** Accordingly, in one aspect of the preferred embodiments, systems and methods are provided for measuring changes in sensitivity, also referred to as changes in solute transport or biointerface changes, of an analyte sensor 10 implanted in a host over a time period. Preferably, the sensitivity measurement is a signal obtained by measuring a constant analyte other than the analyte being measured by the analyte sensor. For example, in a glucose sensor, a non-glucose constant analyte is measured, wherein the signal is measured beneath the membrane system 22 on the glucose sensor 10. While not wishing to be bound by theory, it is believed that by monitoring the sensitivity over a time period, a change associated with solute transport through the membrane system 22 can be measured and used as an indication of a sensitivity change in the analyte measurement. In other words, a biointerface monitor is provided, which is capable of monitoring changes in the biointerface surrounding an implantable device, thereby enabling the measurement of sensitivity changes of an analyte sensor over time.

15 **[0115]** In some embodiments, the analyte sensor 10 is provided with an auxiliary electrode 18 configured as a transport-measuring electrode disposed beneath the membrane system 22. The transport-measuring electrode can be configured to measure any of a number of substantially constant analytes or factors, such that a change measured by the transport-measuring electrode can be used to indicate a change in solute (for example, glucose) transport to the membrane system 22. Some examples of substantially constant analytes or factors that can be measured include, but are not limited to, oxygen, carboxylic acids (such as urea), amino acids, hydrogen, pH, chloride, baseline, or the like. Thus, the transport-measuring electrode provides an independent measure of changes in solute transport to the membrane, and thus sensitivity changes over time.

20 **[0116]** In some embodiments, the transport-measuring electrode measures analytes similar to the analyte being measured by the analyte sensor. For example, in some embodiments of a glucose sensor, water soluble analytes are believed to better represent the changes in sensitivity to glucose over time than non-water soluble analytes (due to the water-solubility of glucose), however relevant information may be ascertained from a variety of molecules. Although some specific examples are described herein, one skilled in the art appreciates a variety of implementations of sensitivity measurements that can be used as to qualify or quantify solute transport through the biointerface of the analyte sensor.

25 **[0117]** In one embodiment of a glucose sensor, the transport-measuring electrode is configured to measure urea, which is a water-soluble constant analyte that is known to react directly or indirectly at a hydrogen peroxide sensing electrode (similar to the working electrode of the glucose sensor example described in more detail above). In one exemplary implementation wherein urea is directly measured by the transport-measuring electrode, the glucose sensor comprises a membrane system as described in more detail above, however, does not include an active interference domain or active enzyme directly above the transport-measuring electrode, thereby allowing the urea to pass through the membrane system to the electroactive surface for measurement thereon. In one alternative exemplary implementation wherein urea is indirectly measured by the transport-measuring electrode, the glucose sensor comprises a membrane system as described in more detail above, and further includes an active uricase oxidase domain located directly above the transport-measuring electrode, thereby allowing the urea to react at the enzyme and produce hydrogen peroxide, which can be measured at the electroactive surface thereon.

30 **[0118]** In some embodiments, the change in sensitivity is measured by measuring a change in oxygen concentration, which can be used to provide an independent measurement of the maturation of the biointerface, and to indicate when recalibration of the system may be advantageous. In one alternative embodiment, oxygen is measured using pulsed amperometric detection on the glucose-measuring working electrode 16 (eliminating the need for a separate auxiliary electrode). In another embodiment, the auxiliary electrode is configured as an oxygen-measuring electrode. In another embodiment, an oxygen sensor (not shown) is added to the glucose sensor, as is appreciated by one skilled in the art, eliminating the need for an auxiliary electrode.

35 **[0119]** In some embodiments, a stability module is provided, wherein the sensitivity measurement changes can be quantified such that a co-analyte concentration threshold is determined. A co-analyte threshold is generally defined as a minimum amount of co-analyte required to fully react with the analyte in an enzyme-based analyte sensor in a non-limiting manner. The minimum co-analyte threshold is preferably expressed as a ratio (for example, a glucose-to-oxygen ratio) that defines a concentration of co-analyte required based on a concentration of analyte available to ensure that the enzyme reaction is limited only by the analyte. While not wishing to be bound by theory, it is believed that by determining a stability of the analyte sensor based on a co-analyte threshold, the processor module can be configured to compensate for instabilities in the glucose sensor accordingly, for example by filtering the unstable data, suspending calibration or display, or the like.

40 **[0120]** In one such embodiment, a data stream from an analyte signal is monitored and a co-analyte threshold set, whereby the co-analyte threshold is determined based on a signal-to-noise ratio exceeding a predetermined threshold. In one embodiment, the signal-to-noise threshold is based on measurements of variability and the sensor signal over a

time period, however one skilled in the art appreciates the variety of systems and methods available for measuring signal-to-noise ratios. Accordingly, the stability module can be configured to set determine the stability of the analyte sensor based on the co-analyte threshold, or the like.

[0121] In some embodiments, the stability module is configured to prohibit calibration of the sensor responsive to the stability (or instability) of the sensor. In some embodiments, the stability module can be configured to trigger filtering of the glucose signal responsive to a stability (or instability) of the sensor.

[0122] In some embodiments, sensitivity changes can be used to trigger a request for one or more new reference glucose values from the host, which can be used to recalibrate the sensor. In some embodiments, the sensor is recalibrated responsive to a sensitivity change exceeding a preselected threshold value. In some embodiments, the sensor is calibrated repeatedly at a frequency responsive to the measured sensitivity change. Using these techniques, patient inconvenience can be minimized because reference glucose values are generally only requested when timely and appropriate (namely, when a sensitivity or baseline shift is diagnosed).

[0123] In some alternative embodiments, sensitivity changes can be used to update calibration. For example, the measured change in transport can be used to update the sensitivity m in the calibration equation. While not wishing to be bound by theory, it is believed that in some embodiments, the sensitivity m of the calibration of the glucose sensor is substantially proportional to the change in solute transport measured by the transport-measuring electrode.

[0124] It should be appreciated by one skilled in the art that in some embodiments, the implementation of sensitivity measurements of the preferred embodiments typically necessitate an addition to, or modification of, the existing electronics (for example, potentiostat configuration or settings) of the glucose sensor and/or receiver.

[0125] In some embodiments, the signal from the oxygen measuring electrode may be digitally low-pass filtered (for example, with a passband of 0-10⁻⁵ Hz, dc-24 hour cycle lengths) to remove transient fluctuations in oxygen, due to local ischemia, postural effects, periods of apnea, or the like. Since oxygen delivery to tissues is held in tight homeostatic control, this filtered oxygen signal should oscillate about a relatively constant. In the interstitial fluid, it is thought that the levels are about equivalent with venous blood (40 mmHg). Once implanted, changes in the mean of the oxygen signal (for example, > 5%) may be indicative of change in transport through the biointerface (change in sensor sensitivity and/or baseline due to changes in solute transport) and the need for system recalibration.

[0126] The oxygen signal may also be used in its unfiltered or a minimally filtered form to detect or predict oxygen deprivation-induced artifact in the glucose signal, and to control display of data to the user, or the method of smoothing, digital filtering, or otherwise replacement of glucose signal artifact. In some embodiments, the oxygen sensor may be implemented in conjunction with any signal artifact detection or prediction that may be performed on the counter electrode or working electrode voltage signals of the electrode system. Co-pending US 2006/015020 describes some methods of signal artifact detection and replacement that may be useful such as described herein.

[0127] Preferably, the transport-measuring electrode is located within the same local environment as the electrode system associated with the measurement of glucose, such that the transport properties at the transport-measuring electrode are substantially similar to the transport properties at the glucose-measuring electrode.

[0128] In a second aspect the preferred embodiments, systems and methods are provided for measuring changes baseline, namely non-glucose related electroactive compounds in the host. Preferably the auxiliary working electrode is configured to measure the baseline of the analyte sensor over time. In some embodiments, the glucose-measuring working electrode 16 is a hydrogen peroxide sensor coupled to a membrane system 22 containing an active enzyme 32 located above the electrode (such as described in more detail with reference to Figs. 1 to 4, above). In some embodiments, the auxiliary working electrode 18 is another hydrogen peroxide sensor that is configured similar to the glucose-measuring working electrode however a portion 34 of the membrane system 22 above the base-measuring electrode does not have active enzyme therein, such as described in more detail with reference to Figs. 3A and 3B. The auxiliary working electrode 18 provides a signal substantially comprising the baseline signal, b , which can be (for example, electronically or digitally) subtracted from the glucose signal obtained from the glucose-measuring working electrode to obtain the signal contribution due to glucose only according to the following equation:

$$\text{Signal}_{\text{glucose only}} = \text{Signal}_{\text{glucose-measuring working electrode}} - \text{Signal}_{\text{baseline-measuring working electrode}}$$

[0129] In some embodiments, electronic subtraction of the baseline signal from the glucose signal can be performed in the hardware of the sensor, for example using a differential amplifier. In some alternative embodiments, digital subtraction of the baseline signal from the glucose signal can be performed in the software or hardware of the sensor or an associated receiver, for example in the microprocessor.

[0130] One aspect the preferred embodiments provides for a simplified calibration technique, wherein the variability of the baseline has been eliminated (namely, subtracted). Namely, calibration of the resultant differential signal (Signal_{glucose only}) can be performed with a single matched data pair by solving the following equation:

$$y = mx$$

5 [0131] While not wishing to be bound by theory, it is believed that by calibrating using this simplified technique, the sensor is made less dependent on the range of values of the matched data pairs, which can be sensitive to human error in manual blood glucose measurements, for example. Additionally, by subtracting the baseline at the sensor (rather than solving for the baseline b as in conventional calibration schemes), accuracy of the sensor may increase by altering control of this variable (baseline b) from the user to the sensor. It is additionally believed that variability introduced by sensor calibration may be reduced.

10 [0132] In some embodiments, the glucose-measuring working electrode 16 is a hydrogen peroxide sensor coupled to a membrane system 22 containing an active enzyme 32 located above the electrode, such as described in more detail above; however the baseline signal is not subtracted from the glucose signal for calibration of the sensor. Rather, multiple matched data pairs are obtained in order to calibrate the sensor (for example using $y = mx + b$) in a conventional manner, and the auxiliary working electrode 18 is used as an indicator of baseline shifts in the sensor signal. Namely, the auxiliary working electrode 18 is monitored for changes above a certain threshold. When a significant change is detected, the system can trigger a request (for example, from the patient or caregiver) for a new reference glucose value (for example, SMBG), which can be used to recalibrate the sensor. By using the auxiliary working electrode signal as an indicator of baseline shifts, recalibration requiring user interaction (namely, new reference glucose values) can be minimized due to timeliness and appropriateness of the requests. In some embodiments, the sensor is re-calibrated responsive to a baseline shifts exceeding a preselected threshold value. In some embodiments, the sensor is calibrated repeatedly at a frequency responsive to the rate-of-change of the baseline.

20 [0133] In yet another alternative embodiment, the electrode system of the preferred embodiments is employed as described above, including determining the differential signal of glucose less baseline current in order to calibrate using the simplified equation ($y = mx$), and the auxiliary working electrode 18 is further utilized as an indicator of baseline shifts in the sensor signal. While not wishing to be bound by theory, it is believed that shifts in baseline may also correlate and/or be related to changes in the sensitivity m of the glucose signal. Consequently, a shift in baseline may be indicative of a change in sensitivity m . Therefore, the auxiliary working electrode 18 is monitored for changes above a certain threshold. When a significant change is detected, the system can trigger a request (for example, from the patient or caregiver) for a new reference glucose value (for example, SMBG), which can be used to recalibrate the sensor. By using the auxiliary signal as an indicator of possible sensitivity changes, recalibration requiring user interaction (new reference glucose values) can be minimized due to timeliness and appropriateness of the requests.

25 [0134] It is noted that infrequent new matching data pairs may be useful over time to recalibrate the sensor because the sensitivity m of the sensor may change over time (for example, due to maturation of the biointerface that may increase or decrease the glucose and/or oxygen availability to the sensor). However, the baseline shifts that have conventionally required numerous and/or regular blood glucose reference measurements for updating calibration (for example, due to interfering species, metabolism changes, or the like) can be consistently and accurately eliminated using the systems and methods of the preferred embodiments, allowing reduced interaction from the patient (for example, requesting less frequent reference glucose values such as daily or even as infrequently as monthly).

30 [0135] An additional advantage of the sensor of the preferred embodiments includes providing a method of eliminating signal effects of interfering species, which have conventionally been problematic in electrochemical glucose sensors. Namely, electrochemical sensors are subject to electrochemical reaction not only with the hydrogen peroxide (or other analyte to be measured), but additionally may react with other electroactive species that are not intentionally being measured (for example, interfering species), which cause an increase in signal strength due to this interference. In other words, interfering species are compounds with an oxidation potential that overlap with the analyte being measured. Interfering species such as acetaminophen, ascorbate, and urate, are notorious in the art of glucose sensors for producing inaccurate signal strength when they are not properly controlled. Some glucose sensors utilize a membrane system that blocks at least some interfering species, such as ascorbate and urate. Unfortunately, it is difficult to find membranes that are satisfactory or reliable in use, especially *in vivo*, which effectively block all interferants and/or interfering species. The prior art is crowded with literature dedicated to efforts toward reducing or eliminating interfering species (for example, see U.S. Patent No. 4,776,944, U.S. Patent No. 5,356,786, U.S. Patent No. 5,593,852, U.S. Patent No. 5776324B1, and U.S. Patent No. 6,356,776).

35 [0136] The preferred embodiments are particularly advantageous in their inherent ability to eliminate the erroneous transient and non-transient signal effects normally caused by interfering species. For example, if an interferant such as acetaminophen is ingested by a host implanted with a conventional implantable electrochemical glucose sensor (namely, one without means for eliminating acetaminophen), a transient non-glucose related increase in signal output would occur. However, by utilizing the electrode system of the preferred embodiments, both working electrodes respond with substantially equivalent increased current generation due to oxidation of the acetaminophen, which would be eliminated

by subtraction of the auxiliary electrode signal from the glucose-measuring electrode signal.

[0137] In summary, the system and methods of the preferred embodiments simplify the computation processes of calibration, decreases the susceptibility introduced by user error in calibration, and eliminates the effects of interfering species. Accordingly, the sensor requires less interaction by the patient (for example, less frequent calibration), increases patient convenience (for example, few reference glucose values), and improves accuracy (via simple and reliable calibration).

[0138] In another aspect of the preferred embodiments, the analyte sensor is configured to measure any combination of changes in baseline and/or in sensitivity, simultaneously and/or iteratively, using any of the above-described systems and methods. While not wishing to be bound by theory, the preferred embodiments provide for improved calibration of the sensor, increased patient convenience through less frequent patient interaction with the sensor, less dependence on the values/range of the paired measurements, less sensitivity to error normally found in manual reference glucose measurements, adaptation to the maturation of the biointerface over time, elimination of erroneous signal due to interfering species, and/or self-diagnosis of the calibration for more intelligent recalibration of the sensor.

[0139] Methods and devices that are suitable for use in conjunction with aspects of the preferred embodiments are disclosed in US 2006/015020 U.S. Patent No. 6,702,857 entitled "MEMBRANE FOR USE WITH IMPLANTABLE DEVICES"; U.S. 6,001,067 issued December 14, 1999 and entitled "DEVICE AND METHOD FOR DETERMINING ANALYTE LEVELS"; U.S. 4,994,167 issued February 19, 1991 and entitled "BIOLOGICAL FLUID MEASURING DEVICE"; and U.S. 4,757,022 filed July 12, 1988 and entitled "BIOLOGICAL FLUID MEASURING DEVICE".

[0140] The term "comprising" as used herein is synonymous with "including," "containing," or "characterized by," and is inclusive or open-ended and does not exclude additional, unrecited elements or method steps.

[0141] All numbers expressing quantities of ingredients, reaction conditions, and so forth used in the specification and claims are to be understood as being modified in all instances by the term "about." Accordingly, unless indicated to the contrary, the numerical parameters set forth in the specification and attached claims are approximations that can vary depending upon the desired properties sought to be obtained by the present invention. At the very least, and not as an attempt to limit the application of the doctrine of equivalents to the scope of the claims, each numerical parameter should be construed in light of the number of significant digits and ordinary rounding approaches.

[0142] The above description discloses several methods and materials of the present invention. This invention is susceptible to modifications in the methods and materials, as well as alterations in the fabrication methods and equipment. Such modifications will become apparent to those skilled in the art from a consideration of this disclosure or practice of the invention disclosed herein. Consequently, it is not intended that this invention be limited to the specific embodiments disclosed herein, but that it cover all modifications and alternatives coming within the true scope of the invention as embodied in the attached claims.

Claims

1. A sensor configured for insertion into a host for measuring an analyte in the host, the sensor comprising:

a first working electrode (16) configured to generate a first signal associated with an analyte related electroactive compound and a non-analyte related electroactive compound, wherein the first electrode is disposed beneath an active enzymatic portion (28) of a membrane system (22) on the sensor;

a second working electrode (18) configured to generate a second signal associated with the non-analyte related electroactive compound, wherein the second electrode is disposed beneath an inactive- or non-enzymatic portion (22) of the membrane system on the sensor; and

electronics operably connected to the first and second working electrodes, wherein the electronics are configured to calculate at least one analyte sensor data point;

characterized in that wherein the first and second working electrodes are juxtapositioned and/or twisted around each other.

2. The sensor of Claim 1, wherein the electronics are configured to subtract the second signal from the first signal, whereby a differential signal comprising the at least one analyte sensor data point is determined.

3. The sensor of Claim 1, wherein the electronics comprise a differential amplifier configured to electronically subtract the second signal from the first signal.

4. The sensor of Claim 1 or 2, wherein the electronics comprises at least one of hardware and software configured to digitally subtract the second signal from the first signal.

5. The sensor of any one of Claims 1 to 4, further comprising a reference electrode, wherein the first working electrode and the second working electrode are operatively associated with the reference electrode.
- 5 6. The sensor of any one of Claims 1 to 4, further comprising a counter electrode, wherein the first working electrode and the second working electrode are operatively associated with the counter electrode.
7. The sensor of any one of Claims 1 to 4, further comprising a first reference electrode and a second reference electrode, wherein the first reference electrode is operatively associated with the first working electrode, and wherein the second reference electrode is operatively associated with the second working electrode.
- 10 8. The sensor of any one of Claims 1 to 4, further comprising a first counter electrode and a second counter electrode, wherein the first counter electrode is operatively associated with the first working electrode, and wherein the second counter electrode is operatively associated with the second working electrode.
- 15 9. The system of any one of Claims 1 to 8, wherein the electronics comprise at least one of hardware or software configured to repeatedly recalibrate at a frequency, wherein the frequency is selected based on the change in the non-analyte related electroactive compound over a time period.
- 20 10. The sensor of any of Claims 1 to 8, wherein the electronics are configured to prohibit calibration of the sensor when a change in the non-analyte related electroactive compound rises above a threshold during a time period.
11. The system of any one of Claims 1 to 8, wherein the electronics comprise at least one of hardware and software configured to filter the at least one analyte sensor data point when a change in the non-analyte related electroactive compound rises above a threshold during a time period.
- 25 12. The system of any one of Claims 1 to 11 wherein a resistance domain is formed on each of the first and second working electrodes.
13. The system of any one of Claims 1 to 12 wherein the electronics are configured to calculate a change in the second signal over a time period.
- 30

Patentansprüche

- 35 1. Sensor, der zum Einsetzen in einen Wirt zur Messung eines Analyten in dem Wirt eingerichtet ist, mit einer ersten Arbeitselektrode (16), die zur Erzeugung eines einer Analyt-bezogenen elektroaktiven Verbindung und einer Nichtanalyt-bezogenen elektroaktiven Verbindung zugeordneten ersten Signals eingerichtet ist, wobei die erste Elektrode auf dem Sensor unter einem aktiven enzymatischen Teil (28) eines Membransystems (22) angeordnet ist,
- 40 einer zweiten Arbeitselektrode (18), die zur Erzeugung eines der Nichtanalyt-bezogenen elektroaktiven Verbindung zugeordneten zweiten Signals eingerichtet ist, wobei die zweite Elektrode auf dem Sensor unter einem inaktiv- oder nicht-enzymatischen Teil des Membransystems (22) angeordnet ist, und der ersten und zweiten Arbeitselektrode verbundener Elektronik, die zur Berechnung wenigstens eines Datenpunkts des Analytsensors eingerichtet ist,
- 45 **dadurch gekennzeichnet, daß** die erste und zweite Arbeitselektrode nebeneinander gelagert und/oder umeinander verdrillt sind.
2. Sensor des Anspruchs 1, bei dem die Elektronik zur Subtraktion des zweiten Signals von dem ersten Signal eingerichtet ist, wodurch eine Signaldifferenz bestimmt wird, die den wenigstens einen Datenpunkt des Analytsensors aufweist.
- 50 3. Sensor des Anspruchs 1, bei dem die Elektronik einen Differentialverstärker umfaßt, der zur elektronischen Subtraktion des zweiten Signals von dem ersten Signal eingerichtet ist.
- 55 4. Sensor des Anspruchs 1 oder 2, bei dem die Elektronik wenigstens eine der Hardware und Software umfaßt, die zur digitalen Subtraktion des zweiten Signals von dem ersten Signal eingerichtet ist.
5. Sensor eines der Ansprüche 1 bis 4, ferner mit einer Bezugselektrode, die der ersten Arbeitselektrode und der

EP 1 711 790 B1

zweiten Arbeitselektrode betriebsmäßig zugeordnet ist.

- 5
6. Sensor eines der Ansprüche 1 bis 4, ferner mit einer Gegenelektrode, die der ersten Arbeitselektrode und die zweite Arbeitselektrode betriebsmäßig zugeordnet ist.
7. Sensor eines der Ansprüche 1 bis 4, ferner mit einer ersten Bezugselektrode und einer zweiten Bezugselektrode, wobei die erste Bezugselektrode betriebsmäßig der ersten Arbeitselektrode zugeordnet ist und die zweite Bezugselektrode betriebsmäßig der zweiten Arbeitselektrode zugeordnet ist.
- 10
8. Sensor eines der Ansprüche 1 bis 4, ferner mit einer ersten Gegenelektrode und einer zweiten Gegenelektrode, wobei die erste Gegenelektrode betriebsmäßig der ersten Arbeitselektrode zugeordnet ist und die zweite Gegenelektrode betriebsmäßig der zweiten Arbeitselektrode zugeordnet ist.
- 15
9. Das System eines der Ansprüche 1 bis 8, bei dem die Elektronik wenigstens eine der Hardware oder Software umfaßt, die zur wiederholten Nacheichung bei einer Frequenz eingerichtet ist, wobei die Frequenz auf Basis der Veränderung der Nichtanalyt-bezogenen elektroaktiven Verbindung während eines Zeitraums ausgewählt ist.
- 20
10. Sensor eines der Ansprüche 1 bis 8, bei dem die Elektronik zur Verhinderung der Eichung des Sensors eingerichtet ist, wenn eine Änderung der Nichtanalyt-bezogenen elektroaktiven Verbindung während eines Zeitraums über einen Schwellenwert ansteigt.
- 25
11. System eines der Ansprüche 1 bis 8, bei dem die Elektronik wenigstens eine der Hardware und Software umfaßt, die zur Filterung des wenigstens einen Datenpunkts des Analysensors eingerichtet ist, wenn eine Änderung der Nichtanalyt-bezogenen elektroaktiven Verbindung während eines Zeitraums über einen Schwellenwert ansteigt.
- 30
12. System eines der Ansprüche 1 bis 11, bei dem auf jeder der ersten und zweiten Arbeitselektrode ein Widerstandsbereich gebildet ist.
13. System eines der Ansprüche 1 bis 12, bei dem die Elektronik zur Berechnung einer Änderung des zweiten Signals während einer Zeitdauer eingerichtet ist.

Revendications

- 35
1. Capteur configuré pour l'insertion chez un hôte, servant à mesurer un analyte chez l'hôte, le capteur comprenant :
- 40
- une première électrode de travail (16) configurée pour générer un premier signal associé à un composé électroactif associé à un analyte et un composé électroactif associé à un non analyte, ladite première électrode étant disposée sous une partie enzymatique active (28) d'un système à membrane (22) sur le capteur ;
- 45
- une deuxième électrode de travail (18) configurée pour générer un deuxième signal associé au composé électroactif associé à un non analyte, la deuxième électrode étant disposée sous une partie inactive ou non enzymatique (22) du système à membrane sur le capteur ; et
- des moyens électroniques raccordés fonctionnellement aux première et deuxième électrodes de travail, les moyens électroniques étant configurés pour calculer au moins un point de données du capteur d'analyte ;
- caractérisé en ce que** les première et deuxième électrodes de travail sont juxtaposées et/ou tordues l'une autour de l'autre.
- 50
2. Capteur selon la revendication 1, dans lequel les moyens électroniques sont configurés pour soustraire le deuxième signal du premier signal, un signal différentiel comprenant au moins un point de donnée du capteur d'analyte étant déterminé.
- 55
3. Capteur selon la revendication 1, dans lequel les moyens électroniques comprennent un amplificateur différentiel configuré pour soustraire électroniquement le deuxième signal du premier signal.
4. Capteur selon la revendication 1 ou 2, dans lequel les moyens électroniques comprennent au moins un matériel et un logiciel configurés pour soustraire numériquement le deuxième signal du premier signal.
5. Capteur selon l'une quelconque des revendications 1 à 4, comprenant en outre une électrode de référence, la

EP 1 711 790 B1

première électrode de travail et la deuxième électrode de travail étant associées fonctionnellement à l'électrode de référence.

- 5
6. Capteur selon l'une quelconque des revendications 1 à 4, comprenant en outre une contre-électrode, la première électrode de travail et la deuxième électrode de travail étant associées fonctionnellement à la contre-électrode.
- 10
7. Capteur selon l'une quelconque des revendications 1 à 4, comprenant en outre une première électrode de référence et une deuxième électrode de référence, la première électrode de référence étant associée fonctionnellement à la première électrode de travail et la deuxième électrode de référence étant associée fonctionnellement à la deuxième électrode de travail.
- 15
8. Capteur selon l'une quelconque des revendications 1 à 4, comprenant en outre une première contre-électrode et une deuxième contre-électrode, la première contre-électrode étant associée fonctionnellement à la première électrode de travail et la deuxième contre-électrode étant associée fonctionnellement à la deuxième électrode de travail.
- 20
9. Système selon l'une quelconque des revendications 1 à 8, dans lequel les moyens électroniques comprennent au moins un matériel ou un logiciel configuré pour être ré-étalonné de façon répétée à une fréquence, la fréquence étant choisie sur la base du changement dans le composé électroactif associé à un non analyte sur une certaine durée.
- 25
10. Capteur selon l'une quelconque des revendications 1 à 8, dans lequel les moyens électroniques sont configurés pour empêcher l'étalonnage du capteur lorsqu'un changement dans le composé électroactif associé à un non analyte dépasse un seuil pendant une certaine durée.
- 30
11. Système selon l'une quelconque des revendications 1 à 8, dans lequel les moyens électroniques comprennent au moins un matériel ou un logiciel configuré pour filtrer au moins un point de données d'un capteur d'analyte lorsqu'un changement dans le composé électroactif associé à un non analyte dépasse un seuil pendant une certaine durée.
- 35
12. Système selon l'une quelconque des revendications 1 à 11, dans lequel un domaine de résistance est formé sur chacune des première et deuxième électrodes de travail.
- 40
- 45
- 50
- 55
13. Système selon l'une quelconque des revendications 1 à 12, dans lequel les moyens électroniques sont configurés pour calculer un changement dans le deuxième signal sur une certaine durée.

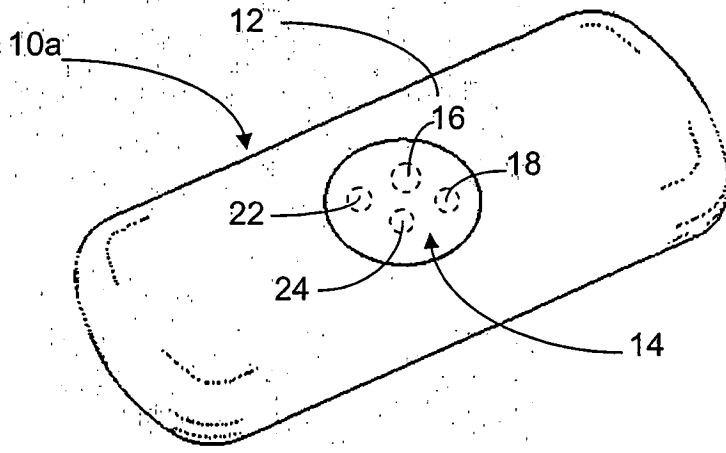

FIG. 1A

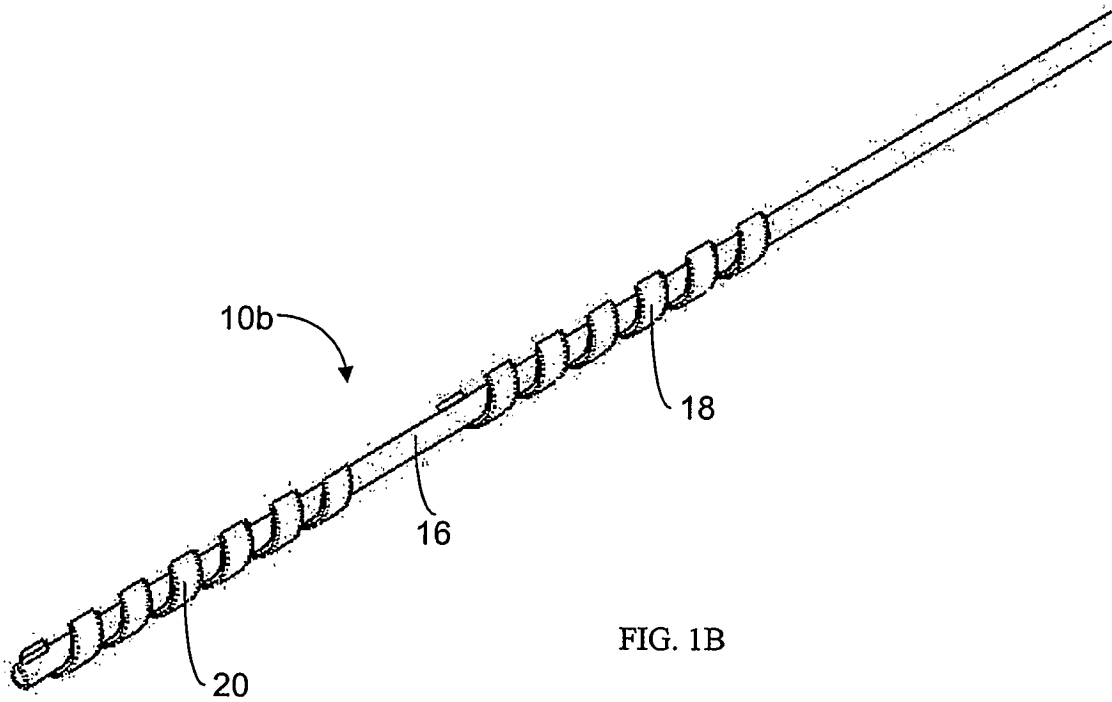
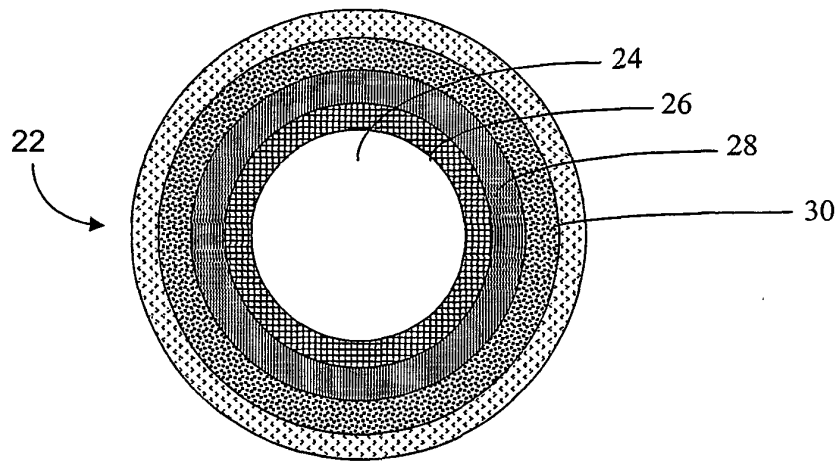
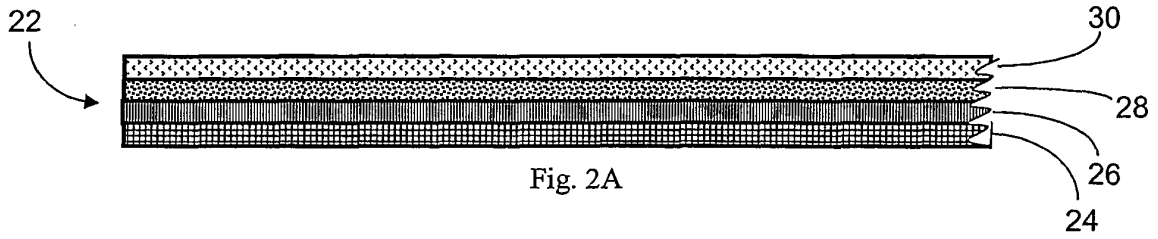

FIG. 1B



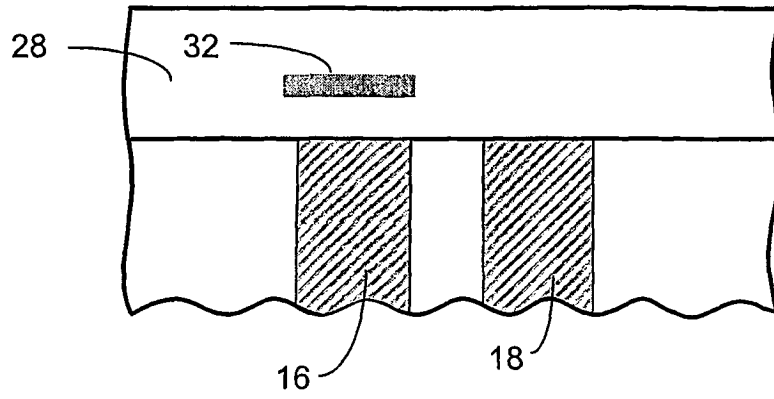

FIG. 3A

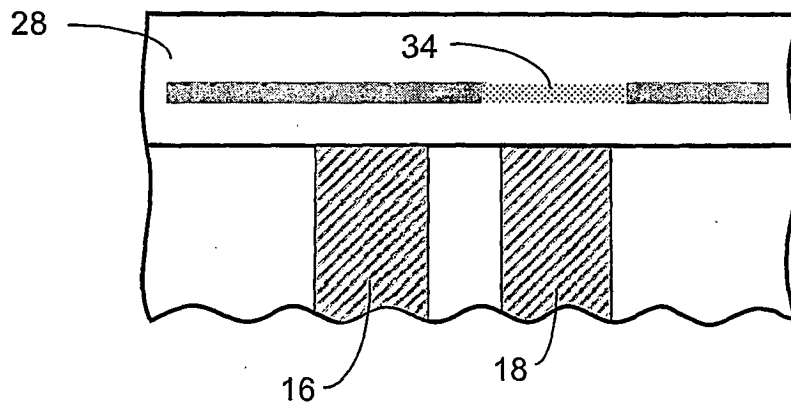

FIG. 3B

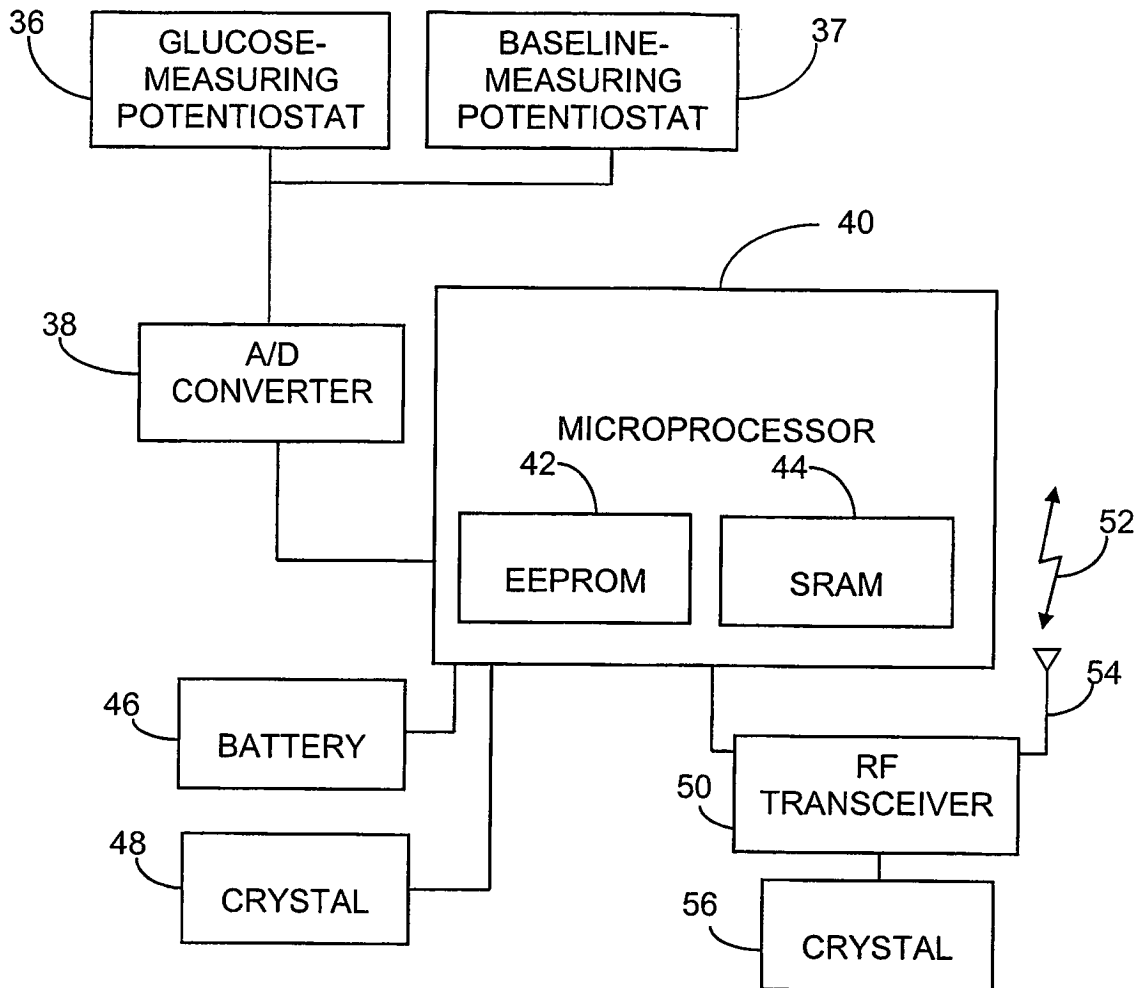

FIG. 4

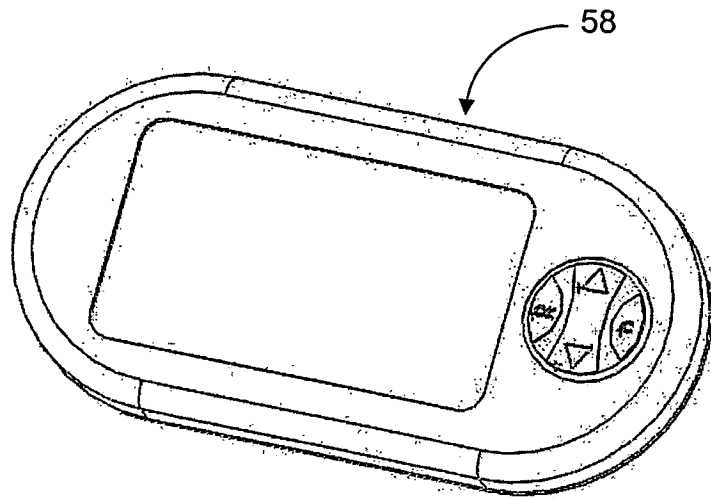

FIG. 5

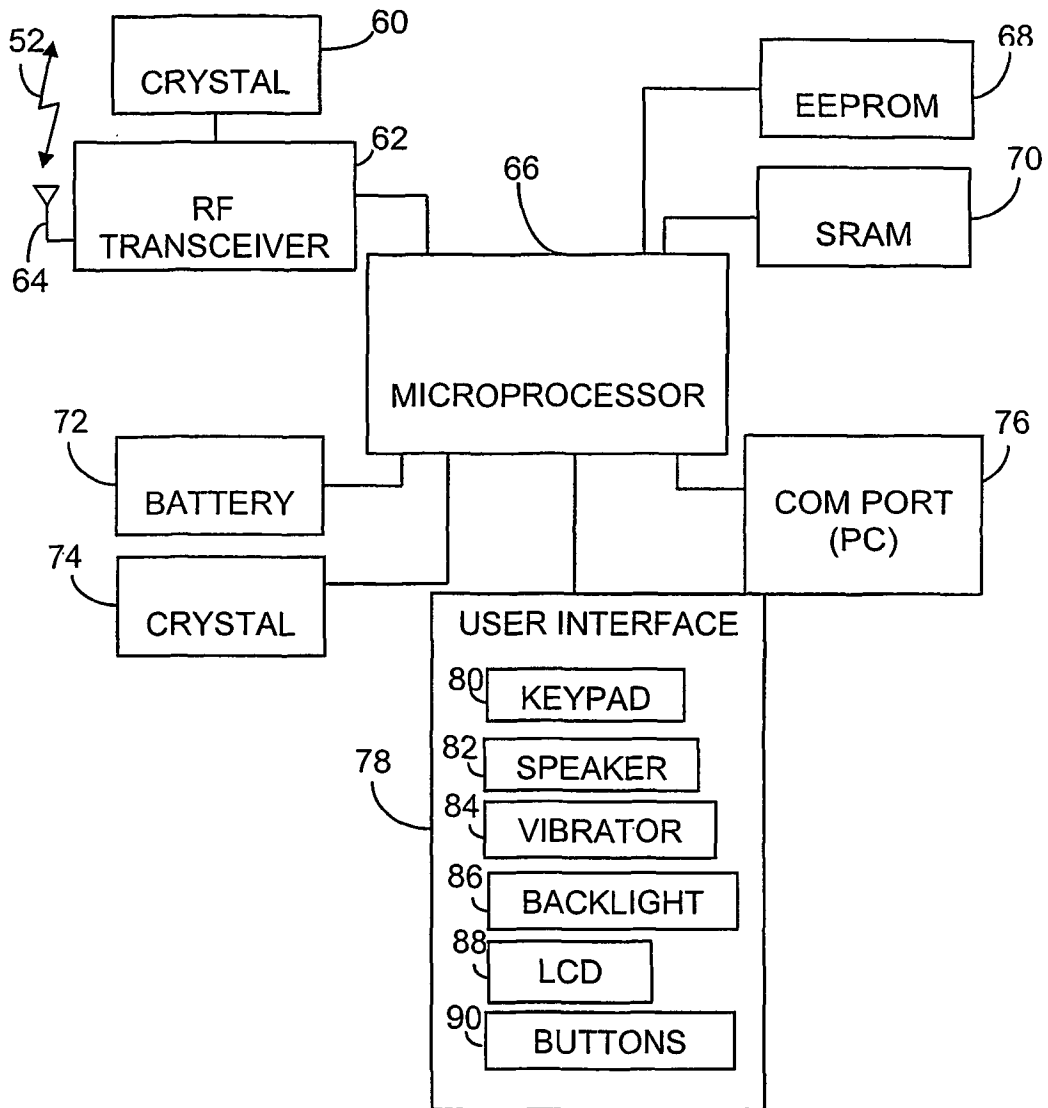

FIG. 6

REFERENCES CITED IN THE DESCRIPTION

This list of references cited by the applicant is for the reader's convenience only. It does not form part of the European patent document. Even though great care has been taken in compiling the references, errors or omissions cannot be excluded and the EPO disclaims all liability in this regard.

Patent documents cited in the description

- US 20030187338 A [0003]
- US 6001067 A [0020] [0065] [0139]
- US 4757022 A [0046] [0139]
- US 5497772 A [0046]
- US 4787398 A [0046]
- US 633367 A [0060] [0100]
- US 2006015020 A [0065] [0066] [0068] [0079] [0080] [0090] [0113] [0126] [0139]
- US 5711861 A, Ward [0078]
- US 6642015 B, Vachon [0078]
- US 6654625 B, Say [0078]
- US 6565509 B, Say [0078] [0085]
- US 6514718 B, Heller [0078]
- US 6465066 B, Essenpreis [0078]
- US 6214185 B, Offenbacher [0078]
- US 5310469 A, Cunningham [0078]
- US 5683562 A, Shaffer [0078]
- US 6579690 B, Bonnezeze [0078]
- US 6484046 B, Say [0078]
- US 6512939 B, Colvin [0078]
- US 6424847 B, Mastrototaro [0078]
- US 838912 A [0081]
- US 6413396 B [0085]
- US 4776944 A [0135]
- US 5356786 A [0135]
- US 5593852 A [0135]
- US 5776324 B1 [0135]
- US 6356776 B [0135]
- US 6702857 B [0139]
- US 4994167 A [0139]

Non-patent literature cited in the description

- **Rhodes et al.** *Anal. Chem.*, 1994, vol. 66, 1520-1529 [0089]

专利名称(译)	连续分析物传感器的校准技术		
公开(公告)号	EP1711790A4	公开(公告)日	2008-07-02
申请号	EP2004812899	申请日	2004-12-03
[标]申请(专利权)人(译)	德克斯康公司		
申请(专利权)人(译)	DEXCOM INC.		
当前申请(专利权)人(译)	DEXCOM INC.		
[标]发明人	KAMATH APURV ULLAS SIMPSON PETER C BRAUKER JAMES H GOODE JR PAUL V		
发明人	KAMATH, APURV, ULLAS SIMPSON, PETER, C. BRAUKER, JAMES, H. GOODE, JR., PAUL, V.		
IPC分类号	G01N1/00 A61B5/00 A61B5/05 G01N		
CPC分类号	A61B5/14532 A61B5/14865 A61B5/1495 A61B5/7203 A61B2560/0223 B33Y70/00 B33Y80/00 A61B5/742		
优先权	60/527323 2003-12-05 US 60/587787 2004-07-13 US 60/614683 2004-09-30 US		
其他公开文献	EP1711790B1 EP1711790A2		
外部链接	Espacenet		

摘要(译)

一种用于处理来自宿主中的葡萄糖传感器的数据的方法，该方法包括：测量与葡萄糖和非葡萄糖相关的电活性化合物相关的第一信号，其中该第一信号是在位于糖的活性酶部分下方的第一电极测量的。膜系统测量与至少一种非葡萄糖相关的电活性化合物相关的第二信号，其中所述第二信号在设置在所述膜系统的非酶部分下方的第二电极处测量；在电子设备中，计算一段时间内第二信号的变化。

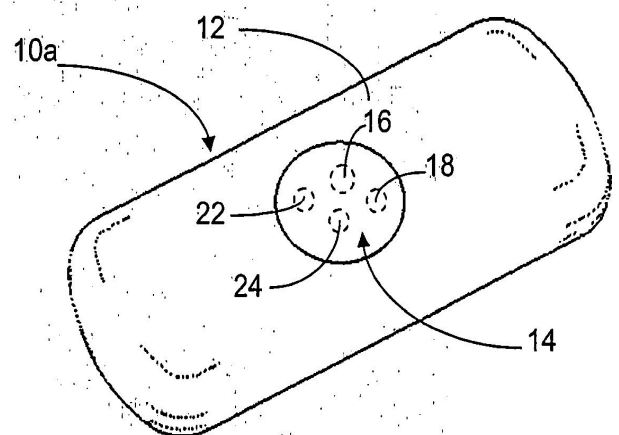

FIG. 1A