

(19)



(11)

**EP 2 465 415 B1**

(12)

**EUROPEAN PATENT SPECIFICATION**

(45) Date of publication and mention of the grant of the patent:  
**03.07.2013 Bulletin 2013/27**

(51) Int Cl.:  
**A61B 5/00** (2006.01)  
**A61B 5/0478** (2006.01) **A61B 5/0408** (2006.01)

(21) Application number: **10195886.6**

(22) Date of filing: **20.12.2010**

(54) **Single-use biomedical sensors**

Biomedizinische Einweg-Sensoren

Capteurs biomédicaux à usage unique

(84) Designated Contracting States:  
**AL AT BE BG CH CY CZ DE DK EE ES FI FR GB GR HR HU IE IS IT LI LT LU LV MC MK MT NL NO PL PT RO RS SE SI SK SM TR**

(43) Date of publication of application:  
**20.06.2012 Bulletin 2012/25**

(73) Proprietor: **General Electric Company Schenectady, NY 12345 (US)**

(72) Inventors:  
• **Ylöstalo, Antti**  
**00710 Helsinki (FI)**  
• **Virtanen, Juha**  
**00660 Helsinki (FI)**

(74) Representative: **Äkräs, Tapio Juhani Kolster Oy Ab**  
**Iso Roobertinkatu 23**  
**P.O. Box 148**  
**00121 Helsinki (FI)**

(56) References cited:  
**WO-A1-2008/005016 US-A1- 2005 131 288**

- **WONG A C W ET AL: "Sensium: an ultra-low-power wireless body sensor network platform: Design & application challenges", 2009 ANNUAL INTERNATIONAL CONFERENCE OF THE IEEE ENGINEERING IN MEDICINE AND BIOLOGY SOCIETY : EMBC 2009 ; MINNEAPOLIS, MINNESOTA, USA, 3 - 6 SEPTEMBER 2009, IEEE, PISCATAWAY, NJ, USA, 3 September 2009 (2009-09-03), pages 6576-6579, XP031639024, ISBN: 978-1-4244-3296-7**

**EP 2 465 415 B1**

Note: Within nine months of the publication of the mention of the grant of the European patent in the European Patent Bulletin, any person may give notice to the European Patent Office of opposition to that patent, in accordance with the Implementing Regulations. Notice of opposition shall not be deemed to have been filed until the opposition fee has been paid. (Art. 99(1) European Patent Convention).

**Description**

## FIELD OF THE INVENTION

**[0001]** The invention relates generally to electrodes for obtaining biosignals from a recording surface, for example a skin of a subject.

## BACKGROUND OF THE INVENTION

**[0002]** When monitoring the vital signs or other physiological parameters of hospitalized patients, sensors are attached on patients' skin or catheters are inserted either into natural openings of the body or catheters are pierced through the skin. The common practice is to connect these sensors with electrically or optically conductive cables to measurement instruments. The instrument may reside either on bedside (e.g. multi-parameter patient monitors in operating room (OR) or in intensive care unit (ICU)) or it may be a relatively small box carried by the patient (e.g. ECG telemetry).

**[0003]** Recent technological development has made it possible to build battery-operated sensors, which include means for performing the actual measurement, converting the measured signals into digital format, and transmitting wirelessly the measurement data and/or calculated parameters to a host device. These devices are referred to as wireless sensors.

**[0004]** Wireless sensors provide obvious benefits for both caregivers and patients. The so-called 'cable clutter' has been recognized as one of the biggest issues in the care process of high-acuity patients. There are lots of cables in the hospitals that also create issues with infections and the usability. By using wireless sensors one can reduce the amount of cables used in a hospital and improve the usability of the different parameters and the total care process. It is not necessary to remove all the cables, but a significant improvement would be achieved by removing only a moderate number of leads or wires. This is because the tendency to tangle up increases disproportionately with the number of cables. The patient group, which would benefit most from the wireless sensors, is low-acuity patients. Being not physically tied to the patient monitor with lead wires, they are free to move around, like visiting the bathroom without assistance. Also in case of a small patient monitor carried by the patient, wireless sensors offer better reliability and are more comfortable for the patient.

**[0005]** Another aspect supporting the use of disposable sensors in hospital environment is the infection control, which has become a big issue. The term "disposable" as used herein refers to a single-use sensor which is used once and then disposed. Totally disposable sensors would make infection control easier. They would also streamline the care process by eliminating the need for cleaning the sensors. If one is able to use disposable single-patient-use sensors, it prevents the spreading of infections and cross contamination inside the hospital.

This also improves the care process by saving time and money.

**[0006]** There are several disposable sensors available in the market such as a depth-of-anesthesia sensor, ECG electrodes, etc. There are also some wireless parameters available in the markets. Most of the wireless parameters are reusable or disposable with changeable or rechargeable battery. All of these variations require charging or special handling of the batteries. The also require special installation when starting to use the parameter because the battery needs to be added to the sensor separately. Difficult maintenance and high cost related to batteries has been the key factor in preventing wireless sensors from becoming widely accepted. Moreover, typically the batteries used needs to be recycled. In order to gain wide acceptance for the wireless sensors, the battery replacement cycle should match the hospital's daily routine and the disposed batteries and sensors should require no special handling

**[0007]** Disposable sensors that contain electrodes (such as ECG, EEG etc...) has limited shelf life for several reasons. Electrodes for measuring biosignals from a recording surface, for example a skin of a patient may be generally classified into dry electrodes or wet electrodes depending on the presence of an electrolyte on the surface attached to the skin. Dry electrodes are mainly applied to the skin using an elastic band. An example of a dry electrode is heart rate meter belt used in sports medicine. On the other hand, wet electrodes may be attached to the skin using a conductive liquid or solid gel to provide a continuous conductive path between the recording surface and the electrode sensing element. Conductive gels may contain a salt, such as KCl or NaCl, in order to achieve electrical current flow. The preferred gel is one with a high salt content, since such a gel produces a better conductor than that obtained when using a gel with low salt content. In addition, the use of a high salt content typically requires less skin abrasion at the time of application to reduce the impedance of the skin-electrode interface after subsequent electrode application. Consequently, biosignal measurement sensor electrodes with high salt content traditionally may have a limited shelf life (maximum storage time prior to use), for example, due to drying of the gel in the electrodes, and also due to the changes that may take place in the sensor materials. Wet gel electrodes provide better contact than dry electrodes: the contact impedance is lower and the signal bandwidth extends to lower frequencies. This is why dry electrodes are typically used in limited applications, such as heart rate measurement, whereas wet gel electrodes are used in diagnostic ECG, where various features of the signal are analysed.

**[0008]** For a long-term storage, e.g. up to about 12 months, wet sensors or sensor electrodes may be stored within an enclosure or a package, which provides a proper atmosphere to prevent the drying of the gel. For example, a pouch laminated with moisture and UV-proof materials, such as aluminum, may be used to prevent

the drying of the gel. As a result there is an atmosphere inside the pouch where humidity may be about 99%. There may be salt (Chloride) present inside the pouch, since the electrolyte gels contains typically KCl or NaCl to enable good signal between the electrode and the tissue. Thus, the humidity and the existence of the salt inside the pouch creates an atmosphere which is really harmful for several materials. This atmosphere corrodes many materials and chlorides or oxidizes them and it requires special attention to the material selections of the sensor.

**[0009]** Examples of biomedical sensors provided on a battery are disclosed in WO 2008/005016 and in "Sensium: an ultra-low-power wireless body sensor network platform: design & application challenges", Wong A C W et al, Conference Proceedings of the international Conference of IEEE Engineering in Medicine and Biology Society (2009), Pages 6576-6579.

#### BRIEF DESCRIPTION OF THE INVENTION

**[0010]** An aspect of the present invention provides a self-powered single-use biomedical sensor comprising a conductive electrolyte material.

**[0011]** Another aspect of the present invention provides a self-powered wireless biomedical sensor comprising a conductive electrolyte material and offering long shelf life.

**[0012]** One or more of these aspects of the invention is achieved with a self-powered biomedical sensor comprising a conductive electrolyte material and withstanding a high humidity and saline storage environment.

**[0013]** The invention further relates to a biomedical sensor, comprising:

a substrate sheet,  
at least one printed electrode on said substrate sheet, the at least one electrode being provided with an electrolyte element to enhance the electrical contact with a surface to be measured, and  
at least one battery encapsulated in a hermetically sealed compartment on said substrate sheet.

Another aspect of the invention is a hermetically sealed package containing a biomedical sensor that comprises

a substrate sheet,  
at least one printed electrode on said substrate sheet, the at least one electrode being provided with an electrolyte element to enhance the electrical contact with a surface to be measured, and  
at least one disposable printed battery encapsulated in a hermetically sealed compartment on said substrate sheet.

#### BRIEF DESCRIPTION OF THE DRAWINGS

**[0014]** In the following exemplary embodiments will be

described in greater detail with reference to the attached drawings, in which

Figure 1 illustrates an example of a prior art biomedical sensor,

Figure 2 illustrates another example of a prior art biomedical sensor,

Figure 3 is a cross-sectional side view of a biomedical self-powered sensor according to an exemplary embodiment,

Figure 4 is a top view of a biomedical self-powered sensor according to an exemplary embodiment, and Figure 5 is a top view of a biomedical self-powered sensor according to an exemplary embodiment.

#### DESCRIPTION OF EXEMPLARY EMBODIMENTS

**[0015]** An electrode for measuring biosignals from a recording surface, for example a skin of a patient, may be called as a 'wet' electrode in presence of an electrolyte on the contact surface attached to the skin. A 'wet' electrode may be attached to the skin using a conductive liquid, hydrogel or solid gel, e.g. electrolyte gel, to improve the electrical conductivity between the recording surface and the electrode sensing element, such as a silver/silver chloride (Ag/AgCl) electrode layer. Typical components of a conductive gel may include water (which acts as the solvent), watersoluble monomers which crosslink to give structure to the gel and which may also provide skin adhesion, humectant materials which reduce the dryout characteristics of the conductive gel, and electrolytes or salts, such as sodium chloride (NaCl) or potassium chloride (KCl) dissolved in water, which provide the ionic conductivity. One advantage of conductive gels over other conductive electrolytes is that they can be removed cleanly from the skin without leaving a residue.

**[0016]** Fig. 1 illustrates, in a side view, an example of a prior art biomedical sensor. The exemplary sensor may include a planar substrate (e.g. a film of non-conducting material, such as plastic), a conductive electrode layer 11 (e.g. silver (Ag) that is chloridised chemically with gel, silver/silver chloride (Ag/AgCl), a gel-carrying element 12 (such as a sponge soaked with a conductive gel) overlaying the conductive electrode layer, and an adhesive layer 10 (e.g. an adhesive foam material) surrounding the gel-carrying element 12 (in the same planar plane) for attaching the electrode to living tissue, for example human forehead or chest. The surrounding adhesive layer 10 may be spaced apart 13 from the gel-carrying element 12. Fig. 2 illustrates, in a side view, another example of a biomedical sensor. The exemplary electrode may include a planar substrate (e.g. a film of non-conducting material, such as plastic), a conductive electrode layer 11 (e.g. silver (Ag), silver/silver chloride (Ag,AgCl), a conductive gel 14 in a solid form ("a solid gel") overlaying the conductive electrode layer 11, and an adhesive layer 10 (e.g. an adhesive foam layer) surrounding the solid

gel (in the same planar plane) for attaching the electrode to living tissue, for example human forehead or chest. In both examples, the conductive electrode layer 11 may contact the gel element 12 or 14 on one side (top side in Figures 1 and 2), and conducting traces (e.g. strips of conductive material provided on the substrate (not shown)) on the other side (bottom side in Figures 1 and 2). The electrode layer 11 is the interface at which ionic conduction through the conductive gel changes to electronic conduction to a monitoring/recording device. The traces, which may be printed or etched, for example, provide electrical connection between the electrode and an associated electronic circuit in the biomedical sensor patch, or via cables to the nearby monitoring device. The traces may also be printed, Ag, or Cu, for example. There may be a single electrode or electrode arrays containing multiple electrodes on the same substrate.

**[0017]** It should be appreciated that the biomedical sensors illustrated above are merely examples of sensors that use a conductive liquid, hydrogel or solid gel, commonly referred to as a conductive electrolyte or gel herein, to improve the electrical conductivity. Embodiments of the invention are not intended to be restricted to any specific sensor type but are applicable to any type of biomedical sensor that use any appropriate electrolyte, such as conductive gel, that must be protected from drying and that create a harmful high-humidity environment. GE Healthcare's Inc's depth-of-anesthesia sensor is a good example of a printed sheet sensor. It contains a substrate, conductive traces, conductive barrier layer and dielectric layer printed with screen-printing, flexo-printing or any other equivalent process. It also contains electrolyte gel to enable biosignal measurement from living tissue. There are also various other sensors manufactured with similar technologies in the market.

**[0018]** "Wet" sensors with an electrolyte on the contact surface may be stored within an enclosure or a package which provides a proper atmosphere to prevent the drying of the electrolyte and prolong the shelf life of the sensors. The humidity (up to 99 %) and the existence of the salt chloride (from the electrolyte) the sealed humidity-impermeable enclosure or package may create an atmosphere which is really harmful for several materials. This atmosphere corrodes many materials and chlorides or oxidizes them and it requires special attention to the material selections of the sensor.

**[0019]** Soft batteries, such as printed batteries are manufactured using methods to create them disposable. These batteries do not contain any environmentally hazardous materials and can be disposed with the sensors without any special handling, such as circulation of batteries. This creates limitations on the material selections. Materials of the printed batteries can not be changed to stand the high humidity and corroding atmosphere. A typical packaging solution for the soft batteries is to use plastic or paper based electrically non-conductive material in making the package. Using of paper based package is not an option in the high humidity environment because

the humidity and the salt would then absorb to the paper and short circuit the battery terminals. Some types of printed batteries may include wet electrolytes and they may be sealed within a plastic sheathing film to prevent liquid evaporation, and are therefore closed electrochemical cells. Being closed cells, these batteries may tend to swell upon storage due to undesirable gas formed within the battery.

**[0020]** Embodiments of the invention provide a disposable "wet" self-powered biomedical sensor comprising a conductive electrolyte material, withstanding a high humidity and saline storage environment, while allowing use of environmentally non-hazard materials in a battery such that no special handling is required at disposal of the sensor. A disposable battery is provided in a hermetically sealed compartment on the sensor structure, such that the unified battery-electrode combination can be stored within the same package or enclosure, such as within the same pouch, having an internal atmosphere with high humidity level, even up to about 99% and saline content since pouch contains electrolyte gel. As a result, a disposable "wet" self-powered biomedical sensor is provided that offers a long shelf life, e.g. a shelf life of the order of 6 - 12 months or more.

**[0021]** An aspect of the invention is to cover a printed disposable battery on the sensor with a humidity-blocking material so as to make the battery tolerant for humidity and saline atmosphere wherein the sensor is stored.

**[0022]** There are several methods to cover the battery to make it tolerant for humidity and saline atmosphere.

**[0023]** According to an aspect of the invention, the battery may be manufactured in the same printing process with the remaining components of the sensor and covered by printing or laminating or other relevant process with humidity and salt resistant layer to enable adequate shelf life.

**[0024]** According to an aspect of the invention, a disposable "wet" self-powered sensor may have a hybrid structure, where the battery may be manufactured separately, attached on top of a sensor substrate sheet, e.g. by adhesive, and covered by printing or laminating or other relevant process with humidity and salt resistant layer to enable adequate shelf life.

**[0025]** According to an aspect of the invention, a disposable "wet" self-powered sensor may have a hybrid structure, where the battery may be manufactured separately, encapsulated hermetically with a humidity resistant material, and the hermetically encapsulated battery may be attached on top of an sensor substrate sheet, e.g. by adhesive.

**[0026]** According to an aspect of the invention, a disposable biomedical sensor comprises at least one printed electrode and at least one printed battery provided on a common substrate. The at least one printed battery is sandwiched between humidity-proof material layers on the common substrate sheet.

**[0027]** According to an exemplary embodiment, a substrate is used that is tolerant to humidity and optimized

for conductive ink printing. Substrate manufacturers may use chemical treatments for the substrate to assist adhesion to water or solvent based printing and coating systems. This also creates a homogenous printing surface that is humidity tolerant. One example of a possible substrate is double-sided chemically coated polyethylene terephthalate (PET) film.

**[0028]** According to an aspect of the invention a disposable battery is integrated into the sensor by manufacturing it in the same process as the actual electrode. Common printing techniques can be employed, such as silk screen printing, flexography, roll-to-roll, etc. The battery may be covered with humidity and salt resistant layer by printing or laminating or other relevant process.

**[0029]** According to an aspect of the invention, a disposable battery may be manufactured or provided on one side of a substrate while a conductive electrode layer and an associated electrolyte gel may be printed on the opposite side of the substrate.

**[0030]** In exemplary embodiments of the invention, the battery manufactured or provided on the substrate may be covered from the top side (the side away from the substrate) with a humidity and heat resistant dielectric layer. There are several dielectric inks available which are designed for humid conditions. One example of this type of dielectric ink is a UV curing dielectric.

**[0031]** In exemplary embodiments of the invention, the battery manufactured or provided on the substrate may be covered from the top side (the side away from the substrate) with a metal layer (such as aluminum) so as to make the battery humidity and salt resistant. The metal layer may be provided by printing or laminating, for example.

**[0032]** According to an aspect of the invention, the hermetically sealed compartment may be capable of accommodating a pressure of gases created inside the battery during storage, such as by expanding, e.g. swelling, and optionally also during the use of the sensor.

**[0033]** According to an aspect of the invention, the hermetically sealed compartment may comprise removable closure member that can be opened when use of the sensor is started so as to release gases created inside the battery out of the battery. For example, the hermetically sealed compartment may comprise an opening or a gas permeable area closed by said removable member during storage.

**[0034]** According to an aspect of the invention, the hermetically sealed compartment may comprise at least locally a material layer that prevents the humidity and salt to go inside but which enables the gases to get out of the battery and prevents the gas pressure.

**[0035]** In exemplary embodiments of the invention, instead of a dielectric or metal layer, another other humidity resistant material may be used to protect the battery layer, such as glass.

**[0036]** In an exemplary embodiment of the invention, there is also a further humidity resistant layer, such as dielectric layer or a metal layer, manufactured between

the substrate and the battery. In another exemplary embodiment, the humidity resistance is provided by the substrate itself, or by any other intermediate layer, and the further special-purpose humidity resistant layer between the substrate and the battery can be omitted.

**[0037]** In an exemplary embodiment of the invention, the top humidity resistant layer and the humidity resistant layer below the battery may be manufactured to join at the surrounding area beyond the periphery of the battery so as to encapsulate the battery into a hermetically sealed compartment or cavity protected from the surrounding humid and saline atmosphere. In exemplary embodiments of the invention, the top humidity resistant layer and the humidity resistant layer below the battery may be sealed together by means of a peripheral seal or layer be manufactured at the surrounding area beyond the periphery of the battery so as to encapsulate the battery into a hermetically sealed compartment protected from the surrounding humid and saline atmosphere.

**[0038]** An illustrating example structure of a biomedical "wet" self-powered sensor which comprises a conductive electrolyte material and withstands a high humidity and saline storage environment is shown in Figure 3. The exemplary sensor is manufactured on a planar substrate 31 by a printing process, laminating process, or any other process which is suitable for creating material layers, or by a combination of two or more processes. For example, some of the layers may be manufactured by printing and other layers by laminating. The substrate 31 may be made of any suitable substrate material, such as those discussed above with reference to Figures 1 and 2.

**[0039]** In the example structure shown in Figure 3, components of a conventional type of biomedical "wet" sensor may be provided on a first flat surface of the substrate 31. More specifically, a conductive electrode layer 33 (e.g. silver (Ag), silver/silver chloride (Ag/AgCl), a gel element 35 (such as a sponge soaked with a conductive gel) overlaying the conductive electrode 33, and an adhesive member layer 34 (e.g. an adhesive foam material) surrounding the gel element 35 (in the same planar plane) for attaching the electrode to living tissue, for example human forehead or chest, may be manufactured on the first surface of the substrate 31. The surrounding adhesive member 34 may be spaced apart from the gel element 35 so as to block transfer of ions between them. For example, in the case the conductive electrode 33 and the gel element 35 have a circular shape in a plane parallel to the first surface of the substrate 31, the surrounding adhesive member may be ring-shaped such that the inner diameter of the adhesive member is large enough to accommodate the electrode 33 and the gel element 35. The conductive electrode layer 35 may contact the gel element 35 on one side (top side in Figure 3), and conducting traces 32 (e.g. strips of conductive material) provided on the substrate 31 on the other side. The traces 32 provide electrical connection between the electrode 33 and an associated electronic circuit (such as an electronic circuit 41 in Figure 4) in the biomedical sensor

patch, or via cables to the nearby monitoring device. The traces may be made of Ag or Cu, for example. Although a single electrode is shown in this example, there may be multiple electrodes on the same substrate. An example of a biomedical sensor having multiple electrodes on the same substrate is shown in Figure 5.

**[0040]** It should be appreciated embodiments of the invention are not intended to be restricted to any specific electrode type but are applicable to any type of biomedical sensor that use any appropriate electrolyte, such as conductive gel, that must be protected from drying and that create a harmful high-humidity environment. Thus, any kind of biomedical "wet" electrode configuration may be provided on the first surface of substrate 31 in place of the configuration shown in Figure 3.

**[0041]** In the example shown in Figure 3, a planar printed battery 30 that is encapsulated by a humidity resistant material on the opposite second flat surface of the substrate 31. This configuration minimizes the substrate area required. However, it should be appreciated that the battery may be located on any surface and at any location on the substrate 31. The printed battery 30 may be sandwiched between humidity-proof material layers 36 and 37 on the substrate sheet 31. Although a special-purpose humidity resistant layer 36 located between the substrate 31 and the battery 30, the humidity resistance may be provided by the substrate itself, e.g. by treatment or coating its surface, in which case the special-purpose humidity resistant layer 36 may unnecessary and omitted. There may also be one or more intermediate layers between the humidity resistant layer 36 and the substrate 31.

**[0042]** The battery 30 may be printed or otherwise attached on the humidity resistant layer 36. For example, the battery 30 may be separately manufactured, e.g. commercially available, battery which is attached in a suitable manner, such as with adhesive. The battery 30 may be covered from the top side (the side away from the substrate 31) with the second humidity resistant layer 37, for example by printing or laminating. The humidity resistant layer 37 may be a dielectric layer or metallic layer, for example. Metal layer may be an aluminum layer or film, for example. The humidity resistant layer 37 may be made of the same or different material as that of the humidity resistant layer 36. In the exemplary embodiment, the top humidity resistant layer 37 and the humidity resistant layer 36 below the battery may be manufactured to join at the surrounding area beyond the periphery of the battery so as to encapsulate the battery 30 into a hermetically sealed compartment (a dry cavity) protected from the surrounding humid and saline atmosphere. Alternatively, the top humidity resistant layer 37 and the humidity resistant layer 36 below the battery may be sealed together by means of a peripheral seal or layer manufactured at the periphery of the battery so as to encapsulate the battery into a hermetically sealed compartment protected from the surrounding humid and saline atmosphere. In the example structure, conductive

traces or wires 38 are provided to extend through the humidity resistant encapsulation of the battery 30 so as to provide the supply voltage to an electronic circuit outside the encapsulation (such as an electronic circuit 41 in Figure 4). Conductive traces 39 may also be provided on the second surface of the substrate 31 to function as supply voltage buses.

**[0043]** In exemplary embodiments of the invention, the hermetically sealed compartment may be capable of accommodating to a pressure of gases created inside the battery during storage. For example, there may be extra space between the battery 30 and the humidity resistant layer 37 to accommodate a small amount of gas. The humidity resistant layer 37 may flexible or otherwise deformable so as to allow expanding, e.g. swelling, of the hermetically sealed battery compartment due to the gases.

**[0044]** In exemplary embodiments, the hermetically sealed compartment may comprise a removable closure member, such as a humidity resistant patch 40. The humidity resistant patch 40 may hermetically seal or close a venting opening, perforation or gas permeable area 43 provided through the humidity resistant layer 37 to the hermetically sealed battery compartment. The venting opening, perforation or gas permeable area 43 may exposed or opened by removing or opening the patch 40 when the use of the sensor is started to release gases created inside the battery out of the battery. This approach may be especially advantageous, when relatively inflexible or rigid humidity resistant layer 37 is employed. The majority of gas formation may happen during the use of battery, and thus the associated problems are alleviated or avoided.

**[0045]** Figure 4 is a top view of an exemplary biomedical sensor shown in Figure 3. In the example shown in Figure 4 the substrate 31 of the sensor is oval-shaped but it may have any arbitrary shape depending on the application. The battery 30 may be covered by the top humidity resistant layer 37 which extend beyond the periphery of the battery 30, thereby encapsulating the battery 30. The removable closure member, such as a humidity resistant patch 40, may be provided on the top of the layer 37. Conductive traces or wires 38 may extend from the (+) and (-) terminals of the battery 30 through the humidity resistant encapsulation 37 to the electronic circuit(s) 41 outside the encapsulation. Alternatively, the electronic circuit(s) 41 may be within the encapsulation, or remote from the battery.

**[0046]** Figure 5 is a top view of another exemplary biomedical sensor having multiple (two or more) electrode patches 51, 52, 53. One or more of the electrode patches may be provided with a printed battery 30. The electrode patch 51 may have a connector 54 for connecting a separate electronic circuit 55 to which biosignals and/or the supply voltage from the battery 30 are delivered. The electronic circuit 55 may be reused, while the biomedical sensor with the battery or batteries 30 is disposable single-use product.

**[0047]** Flexible "printable" batteries are commonly available in the markets. For example Enfucell Inc. makes flexible and thin batteries using low cost environmentally friendly materials. The main active components in the batteries are zinc, manganese dioxide and zinc chloride as an electrolyte. When disposed, these batteries require no special treatment, but can be thrown into a normal waste basket together with the electrode. The batteries are manufactured by printing in a roll-to-roll process. SoftBattery® from Enfucell Inc is manufactured with Enfucell allPrinted™ technology. The same or similar technology may be used also then manufacturing the battery 30 on the substrate by printing in the same process with the remaining components of the sensor.

**[0048]** The electronic circuit 42 or 54 may be any electronic circuit associated with the specific biosignal measurement. For example, the electronic circuit may comprise a signal amplifier, a signal processor, a data processor, a data memory, a wireless transmitter, a wireless transceiver, a wired or wireless communication interface, or any combination thereof. For example, the electronic circuit may comprise an ECG-amplifier with body area network connection and operated (e.g. over 24 hours) from the soft battery 30. When the electronic circuit is provided with a wireless transmitter, wireless transceiver, or a wireless communication interface, a self-powered wireless biomedical sensor is achieved. When the electronic circuit is provided with a memory, measured biosignal data may be collected and stored in the memory energized by the battery 30 for subsequent downloading to a reading or monitoring device. In other words, a data logger may be provided. The electronic circuit (e.g. an amplifier, memory and/or transmitter) may be either a separate piece of hardware (such as the electronic circuit 55 in Figure 5), or the electronics may be built to be part of the disposable electrode sheet (such as the electronic circuit 41 in Figure 4).

**[0049]** In an alternative exemplary embodiment, the battery 30 may be manufactured separately, attached to the humidity resistant layer 36 on the substrate 31, and then covered by the second humidity resistant layer 37 in order to encapsulate the battery 30.

**[0050]** In a still alternative exemplary embodiment, the battery 30 may be manufactured separately, covered by the humidity resistant layers 36 and 37 in order to encapsulate the battery 30, such that the encapsulated battery 30 (with the humidity resistant layers) can be attached on the substrate 31.

**[0051]** In a still alternative exemplary embodiment, the battery 30 may be manufactured separately, the humidity resistant layers 36 and 37 may be formed by a package, such as a pouch of humidity resistant material, within which the battery 30 is inserted and sealed in order to hermetically encapsulate the battery 30, such that the package encapsulating the battery 30 can be attached on the substrate 31. The package may be a metallic (e.g. aluminum) pouch similar to a pouch that is used for packaging of biomedical "wet" electrodes. Suitable traces or

wires 38 may be taken out of the encapsulated battery to provide the supply voltage to an external electronic circuit (such as circuit 41 in Figure 4). The resulting hybrid structure may result in a similar arrangement as shown in Figures 3 and 4, the reference numerals 36 and 37 depicting the package or pouch of the battery 30.

**[0052]** Exemplary embodiments of the invention allow storing of a disposable self-powered sensor within an enclosure or a package which provides a proper atmosphere to prevent the drying of the electrolyte and prolong the shelf life of the sensors. For example, diagnostic quality ECG sensors can be stored in the same pouch with the soft battery. In Figure 4, the dash line 42 depicts a hermetic package or pouch for storing the biomedical sensor provided with a soft battery.

**[0053]** Embodiments of the invention provide various advantages. A disposable power source (with capacity for operation over a required monitoring period, such as 24 hours) on a biomedical sensor is a perfect fit with hospital's logistics and care process. Infection control in hospitals is improved. No extra work from maintaining or special handling of the batteries of wireless sensors (e.g. recycling) is needed. Use of wireless sensors reduces the cable clutter in the hospital. A low cost highly integrated solution is enabled.

**[0054]** This written description uses examples to disclose the invention, including the best mode, and also to enable any skilled person to make and use the invention. The patentable scope of the invention is defined by the claims.

## Claims

1. A biomedical sensor, comprising:
  - a substrate sheet (31),
  - at least one printed electrode (33) on said substrate sheet, the at least one electrode (33) being provided with an electrolyte element (35) to enhance the electrical contact with a surface to be measured, and
  - at least one printed battery (30) encapsulated in a hermetically sealed compartment (36,37) on said substrate sheet (31).
2. A biomedical sensor according to claim 1, wherein the hermetically sealed compartment is confined between humidity-proof material layers (36,37) on the common substrate sheet (31).
3. A biomedical sensor according to claim 2, wherein one of the humidity-proof layers comprises the substrate sheet (31) made of humidity-proof material or chemically treated to be humidity-proof.
4. A biomedical sensor according to claim 2 or 3, wherein one of the humidity-proof layers comprises a hu-

humidity-proof material layer (37) covering a top of the battery (30).

5. A biomedical sensor according to any one of claims 2 to 4, wherein at least one of the humidity-proof material layers (36,37) comprises a metal layer or a dielectric layer.
6. A biomedical sensor according to any one of claims 1 to 5, wherein the battery (30) comprises a battery manufactured in the same printing process with the remaining components of the electrode and covered by printing or laminating process with a humidity-proof layer (37).
7. A biomedical sensor according to any one of claims 1 to 5, wherein the battery (30) comprises a separately manufactured battery attached on top of an electrode substrate sheet (31) and covered by pointing or laminating process with a humidity-proof layer (37).
8. A biomedical sensor according to any one of claims 1 to 5, wherein the battery comprises a separately manufactured, with a humidity resistant material hermetically encapsulated battery attached on top of an electrode substrate sheet (31).
9. A biomedical sensor according to any one of claims 1 to 8, wherein the hermetically sealed compartment is capable of accommodating to a pressure of gases created inside the battery (30) during storage, and optionally also during the use of the sensor, and/or wherein the hermetically sealed compartment comprises an opening or a gas permeable area closed by a removable closure member during storage, the removable closure member being opened when use of the sensor is started so as to vent out gases created inside the battery through said opening or a gas permeable area.
10. A biomedical sensor according to any one of claims 1 to 9, comprising an electronic circuit (41) energized from the battery.
11. A biomedical sensor according to claim 10, wherein said electronic circuit (41) is configured for wireless transmission of biomedical measurement data.
12. A biomedical sensor according to any one of claims 10 to 11, wherein said electronic circuit (41) is configured to store biomedical measurement data.
13. A biomedical sensor according to any one of claims 10 to 12, wherein said electronic circuit (41) is configured to process biomedical measurement data.
14. A hermitically sealed package (42) containing a bi-

omedical sensor according to any one of claims 1 to 13.

- 5 15. A hermitically sealed package according to claim 14, wherein the package is a pouch made of aluminum foil.

#### Patentansprüche

- 10 1. Biomedizinischer Sensor mit:
  - 15 einer Substratplatte (31),
  - zumindest einer gedruckten Elektrode (33) auf der besagten Substratplatte, wobei die zumind-
  - 20 dest eine Elektrode (33) mit einem Elektrolytelement (35) versehen ist, um den elektrischen Kontakt mit einer zu messenden Oberfläche zu fördern, und
  - zumindest einer gedruckten Batterie (30), die in einer hermetisch dichten Kammer (36, 37) auf der besagten Substratplatte (31) eingekapselt ist.
- 25 2. Biomedizinischer Sensor nach Anspruch 1, worin die hermetisch dichte Kammer zwischen feuchtigkeitsdichten Materialschichten (36, 37) auf der gemeinsamen Substratplatte (31) eingeschlossen ist.
- 30 3. Biomedizinischer Sensor nach Anspruch 2, worin eine der feuchtigkeitsdichten Schichten die Substratplatte (31) aufweist, die aus einem feuchtigkeitsdichten Material hergestellt ist oder chemisch behandelt ist, feuchtigkeitsdicht zu sein.
- 35 4. Biomedizinischer Sensor nach Anspruch 2 oder 3, worin eine der feuchtigkeitsdichten Schichten eine feuchtigkeitsdichte Materialschicht (37) aufweist, die den oberen Teil der Batterie (30) bedeckt.
- 40 5. Biomedizinischer Sensor nach einem der Ansprüche 2 bis 4, worin zumindest eine der feuchtigkeitsdichten Materialschichten (36, 37) eine Metallschicht oder eine dielektrische Schicht aufweist.
- 45 6. Biomedizinischer Sensor nach einem der Ansprüche 1 bis 5, worin die Batterie (30) eine Batterie aufweist, die in demselben Druckprozess mit den restlichen Komponenten der Elektrode hergestellt und in einem Druck- oder Laminierungsprozess mit einer feuchtigkeitsdichten Schicht (37) bedeckt ist.
- 50 7. Biomedizinischer Sensor nach einem der Ansprüche 1 bis 5, worin die Batterie (30) eine separat hergestellte Batterie aufweist, die am oberen Teil einer Elektrodensubstratplatte (31) befestigt und in einem Druck- oder Laminierungsprozess mit einer feuchtigkeitsdichten Schicht (37) bedeckt ist.
- 55

8. Biomedizinischer Sensor nach einem der Ansprüche 1 bis 5, worin die Batterie eine separat hergestellte, mit einem feuchtigkeitsbeständigen Material hermetisch eingekapselte Batterie aufweist, die am oberen Teil einer Elektrodensubstratplatte (31) befestigt ist. 5
9. Biomedizinischer Sensor nach einem der Ansprüche 1 bis 8, worin sich die hermetisch dichte Kammer an einen Druck von innerhalb der Batterie (30) während der Lagerung, und wahlweise auch während der Verwendung des Sensors, ausgebildeten Gasen anpassen kann und/oder worin die hermetisch dichte Kammer eine Öffnung oder einen gasdurchlässigen Bereich aufweist, die/der während der Lagerung durch ein entfernbares Verschlussstück geschlossen ist, welches entfernbares Verschlussstück geöffnet wird, wenn die Verwendung des Sensors begonnen wird, um innerhalb der Batterie ausgebildete Gase durch die besagte Öffnung oder einen gasdurchlässigen Bereich nach aussen zu entlüften. 10
10. Biomedizinischer Sensor nach einem der Ansprüche 1 bis 9, der eine elektronische Schaltung (41) aufweist, der Energie von der Batterie zugeführt wird. 15
11. Biomedizinischer Sensor nach Anspruch 10, worin die besagte elektronische Schaltung (41) für drahtlose Übertragung von biomedizinischen Messdaten konfiguriert ist. 20
12. Biomedizinischer Sensor nach einem der Ansprüche 10 bis 11, worin die besagte elektronische Schaltung (41) konfiguriert ist, biomedizinische Messdaten zu speichern. 25
13. Biomedizinischer Sensor nach einem der Ansprüche 10 bis 12, worin die besagte elektronische Schaltung (41) konfiguriert ist, biomedizinische Messdaten zu verarbeiten. 30
14. Hermetisch dichte Verpackung (42), die einen biomedizinischen Sensor nach einem der Ansprüche 1 bis 13 enthält. 35
15. Hermetisch dichte Verpackung nach Anspruch 14, worin die Verpackung ein aus einer Aluminiumfolie hergestellter Beutel ist. 40

#### Revendications

1. Capteur biomédical comprenant : 50
- une feuille de substrat (31),  
au moins une électrode (33) imprimée sur ladite  
feuille de substrat, la au moins une électrode  
(33) étant pourvue d'un élément électrolytique  
(35) pour améliorer le contact électrique avec 55
2. Capteur biomédical selon la revendication 1, dans lequel le compartiment hermétiquement scellé est confiné entre des couches de matériau étanche à l'humidité (36, 37) sur la feuille de substrat (31) commune.
3. Capteur biomédical selon la revendication 2, dans lequel l'une des couches étanches à l'humidité comprend la feuille de substrat (31) réalisée dans un matériau étanche à l'humidité ou chimiquement traité pour être étanche à l'humidité.
4. Capteur biomédical selon la revendication 2 ou 3, dans lequel l'une des couches étanches à l'humidité comprend une couche de matériau étanche à l'humidité (37) recouvrant une partie supérieure de la batterie (30).
5. Capteur biomédical selon l'une quelconque des revendications 2 à 4, dans lequel au moins l'une des couches de matériau étanche à l'humidité (36, 37) comprend une couche métallique ou une couche diélectrique.
6. Capteur biomédical selon l'une quelconque des revendications 1 à 5, dans lequel la batterie (30) comprend une batterie fabriquée au cours du même processus d'impression que les composants restants de l'électrode et recouverte, par un processus d'impression ou de lamification, d'une couche étanche à l'humidité (37).
7. Capteur biomédical selon l'une quelconque des revendications 1 à 5, dans lequel la batterie (30) comprend une batterie fabriquée séparément attachée sur une feuille de substrat d'électrode (31) et recouverte, par un processus d'impression ou de lamification, d'une couche étanche à l'humidité (37).
8. Capteur biomédical selon l'une quelconque des revendications 1 à 5, dans lequel la batterie comprend une batterie fabriquée séparément, avec un matériau résistant à l'humidité encapsulé hermétiquement, attachée sur une feuille de substrat d'électrode (31).
9. Capteur biomédical selon l'une quelconque des revendications 1 à 8, dans lequel le compartiment hermétiquement scellé est capable de supporter une pression de gaz créée à l'intérieur de la batterie (30) pendant le stockage, et éventuellement également pendant l'utilisation du capteur, et/ou dans lequel le compartiment hermétiquement scellé comprend une

ouverture ou une zone perméable au gaz fermée par un élément de fermeture amovible pendant le stockage, l'élément de fermeture amovible étant ouvert lorsque l'utilisation du capteur débute de manière à évacuer les gaz créés à l'intérieur de la batterie à travers ladite ouverture ou une zone perméable au gaz. 5

10. Capteur biomédical selon l'une quelconque des revendications 1 à 9, comprenant un circuit électronique (41) alimenté par la batterie. 10
11. Capteur biomédical selon la revendication 10, dans lequel ledit circuit électronique (41) est configuré pour transmettre sans fil des données de mesure biomédicales. 15
12. Capteur biomédical selon l'une quelconque des revendications 10 à 11, dans lequel ledit circuit électronique (41) est configuré pour stocker des données de mesure biomédicales. 20
13. Capteur biomédical selon l'une quelconque des revendications 10 à 12, dans lequel ledit circuit électronique (41) est configuré pour traiter des données de mesure biomédicales. 25
14. Paquet hermétiquement scellé (42) contenant un capteur biomédical selon l'une quelconque des revendications 1 à 13. 30
15. Paquet hermétiquement scellé selon la revendication 14, le paquet étant un sachet constitué d'une feuille d'aluminium. 35

40

45

50

55

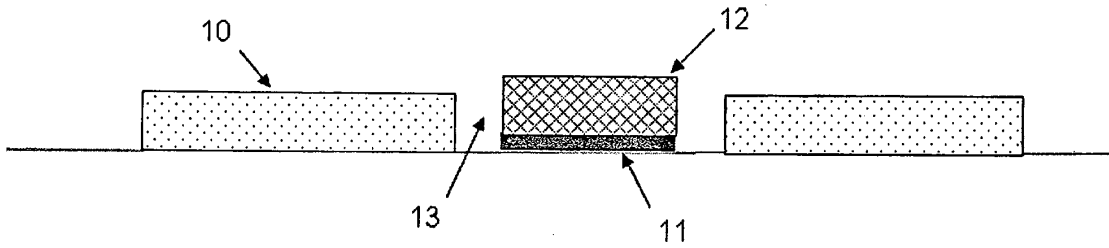

Fig. 1

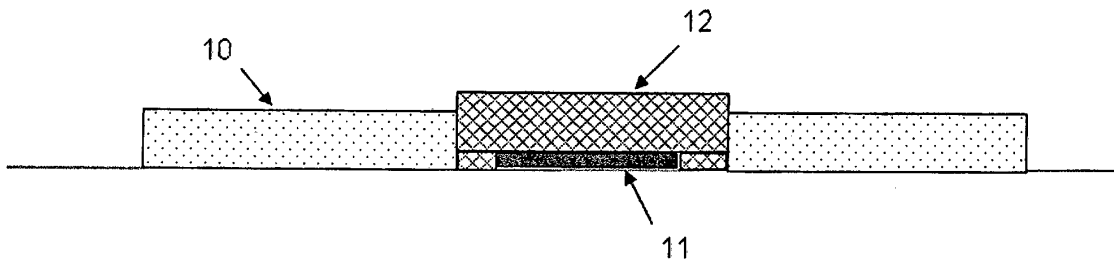

Fig. 2

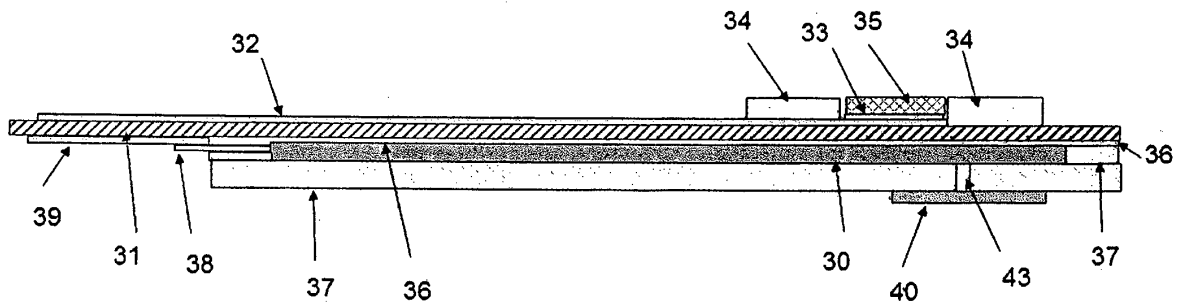

Fig. 3

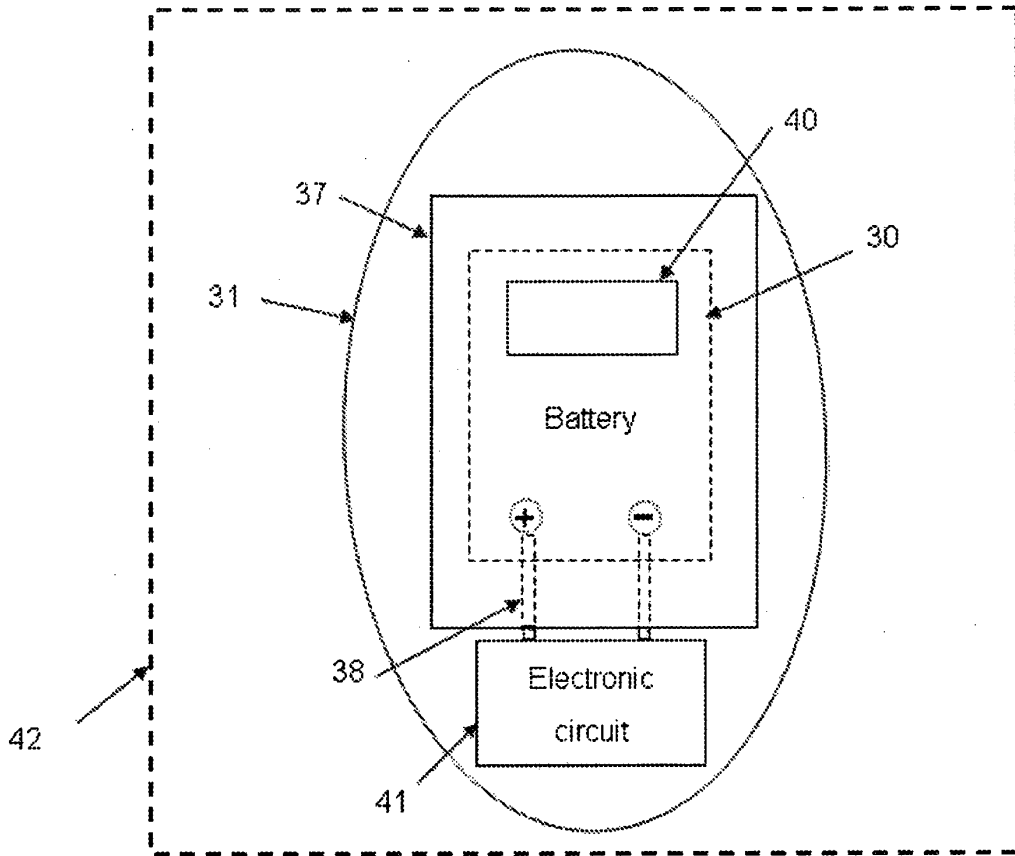

Fig. 4

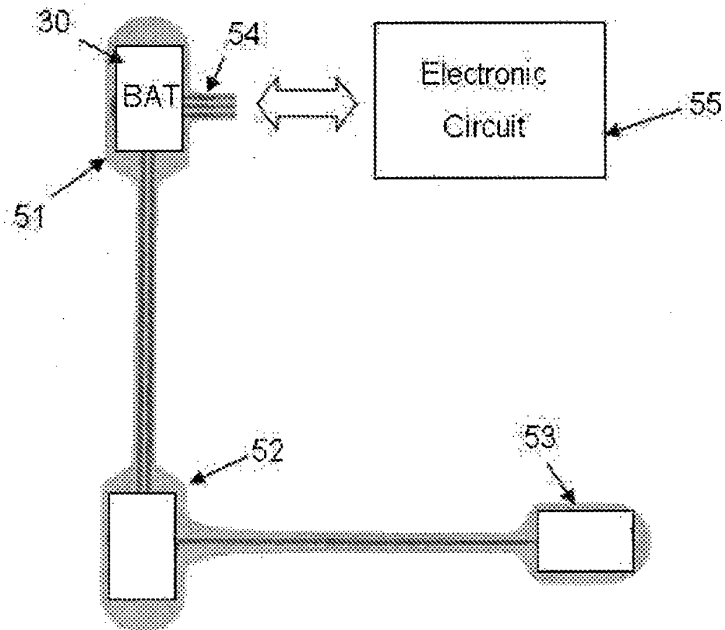

Fig. 5

**REFERENCES CITED IN THE DESCRIPTION**

*This list of references cited by the applicant is for the reader's convenience only. It does not form part of the European patent document. Even though great care has been taken in compiling the references, errors or omissions cannot be excluded and the EPO disclaims all liability in this regard.*

**Patent documents cited in the description**

- WO 2008005016 A [0009]

**Non-patent literature cited in the description**

- **WONG A C W et al.** Sensium: an ultra-low-power wireless body sensor network platform: design & application challenges. *Conference Proceedings of the international Conference of IEEE Engineering in Medicine and Biology Society*, 2009, 6576-6579 [0009]

专利名称(译)	一次性生物医学传感器		
公开(公告)号	<a href="#">EP2465415B1</a>	公开(公告)日	2013-07-03
申请号	EP2010195886	申请日	2010-12-20
[标]申请(专利权)人(译)	通用电气公司		
申请(专利权)人(译)	通用电气公司		
当前申请(专利权)人(译)	通用电气公司		
[标]发明人	YLOSTALO ANTTI VIRTANEN JUHA		
发明人	YLÖSTALO, ANTTI VIRTANEN, JUHA		
IPC分类号	A61B5/00 A61B5/0408 A61B5/0478		
CPC分类号	A61B5/0408 A61B5/0006 A61B5/04087 A61B5/0478 A61B5/0492 A61B5/6833 A61B2560/0412 A61B2562/0215 A61B2562/0217 A61B2562/125 A61B2562/164		
其他公开文献	EP2465415A1		
外部链接	<a href="#">Espacenet</a>		

摘要(译)

一次性自供电生物医学传感器包括在基板片上的印刷湿电极。湿电极设置有电解质元件，以增强与待测表面的电接触。此外，封装在气密封隔壁中的印刷电池设置在基板片上。一次性自供电传感器可以存储在外壳或包装内，该外壳或包装提供适当的气氛以防止电解质的干燥并延长传感器的保存期限。

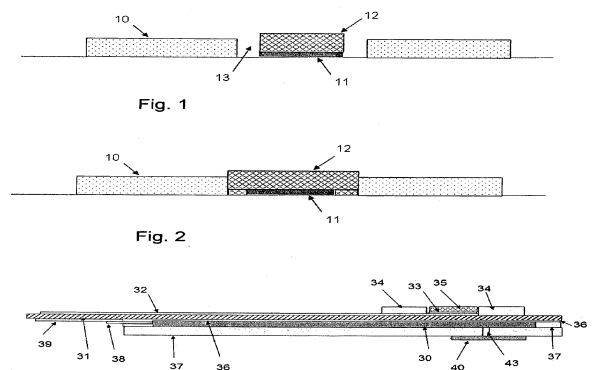

Fig. 3