

(19) World Intellectual Property Organization  
International Bureau



(43) International Publication Date  
31 May 2007 (31.05.2007)

PCT

(10) International Publication Number  
**WO 2007/061755 A2**

(51) International Patent Classification:  
A61B 5/00 (2006.01)

(21) International Application Number:  
PCT/US2006/044515

(22) International Filing Date:  
16 November 2006 (16.11.2006)

(25) Filing Language: English

(26) Publication Language: English

(30) Priority Data:  
11/282,947 18 November 2005 (18.11.2005) US

(71) Applicant (for all designated States except US): **NELLCOR PURITAN BENNETT INCORPORATED** [US/US]; 4280 HACIENDA DRIVE, Pleasanton, CA 94588 (US).

(72) Inventors; and

(75) Inventors/Applicants (for US only): **BAKER, Clarke, R., Jr.** [US/US]; 18493 Magee Way, Castro Valley, CA 94546 (US). **SCHMITT, Joseph** [US/US]; 102 BROOKSIDE DRIVE, Andover, MA 01810 (US).

(74) Agent: **SLAYDEN, Bruce, W., II**; Baker Botts L.L.P., 1500 San Jacinto Center, 98 San Jacinto Blvd., Austin, TX 78701 (US).

(81) Designated States (unless otherwise indicated, for every kind of national protection available): AE, AG, AL, AM,

AT, AU, AZ, BA, BB, BG, BR, BW, BY, BZ, CA, CH, CN, CO, CR, CU, CZ, DE, DK, DM, DZ, EC, EE, EG, ES, FI, GB, GD, GE, GH, GM, GT, HN, HR, HU, ID, IL, IN, IS, JP, KE, KG, KM, KN, KP, KR, KZ, LA, LC, LK, LR, LS, LT, LU, LV, LY, MA, MD, MG, MK, MN, MW, MX, MY, MZ, NA, NG, NI, NO, NZ, OM, PG, PH, PL, PT, RO, RS, RU, SC, SD, SE, SG, SK, SL, SM, SV, SY, TJ, TM, TN, TR, TT, TZ, UA, UG, US, UZ, VC, VN, ZA, ZM, ZW.

(84) Designated States (unless otherwise indicated, for every kind of regional protection available): ARIPO (BW, GH, GM, KE, LS, MW, MZ, NA, SD, SL, SZ, TZ, UG, ZM, ZW), Eurasian (AM, AZ, BY, KG, KZ, MD, RU, TJ, TM), European (AT, BE, BG, CH, CY, CZ, DE, DK, EE, ES, FI, FR, GB, GR, HU, IE, IS, IT, LT, LU, LV, MC, NL, PL, PT, RO, SE, SI, SK, TR), OAPI (BF, BJ, CF, CG, CI, CM, GA, GN, GQ, GW, ML, MR, NE, SN, TD, TG).

**Declarations under Rule 4.17:**

- as to applicant's entitlement to apply for and be granted a patent (Rule 4.17(ii))
- as to the applicant's entitlement to claim the priority of the earlier application (Rule 4.17(iii))

**Published:**

- without international search report and to be republished upon receipt of that report

For two-letter codes and other abbreviations, refer to the "Guidance Notes on Codes and Abbreviations" appearing at the beginning of each regular issue of the PCT Gazette.

(54) Title: SYSTEMS AND METHODS TO ASSESS ONE OR MORE BODY FLUID METRICS

(57) Abstract: The present disclosure provides systems, devices, and/or methods for assessing body fluid-related metrics and/or changes therein. The disclosure further provides systems, devices, and/or methods for correlating body fluid-related metrics in a particular tissue with the corresponding whole-body metric. The disclosure also provides, systems, devices, and/or methods for assessment of such metrics to facilitate diagnosis and/or therapeutic interventions related to maintaining and/or restoring body fluid balance.



WO 2007/061755 A2

SYSTEMS AND METHODS TO ASSESS ONE OR MORE BODY FLUID  
METRICS

RELATED APPLICATION

U.S. patent application No. 10/699,610, filed on  
October 30, 2003, which is a continuation-in-part of U.S.  
patent application No. 10/441,943, filed on May 20, 2003,  
5 which is a continuation of U.S. patent application No.  
09/810,918, filed on Mar. 16, 2001, now U.S. Pat. No.  
6,591,122, and are incorporated herein by reference.

TECHNICAL FIELD

The present disclosure is related to devices and  
10 methods for assessing and evaluating one or more body-  
fluid metrics.

BACKGROUND

Dehydration may be associated with increased risk of  
developing dental disease, urinary tract infections,  
15 broncho-pulmonary disorders, kidney stones, constipation,  
poor immune function, cardiovascular pathologies, and  
impaired cognitive function. The maintenance of body  
fluid balance may often be one of the foremost concerns  
in the care and treatment of critically ill patients, yet  
20 physicians have access to few diagnostic tools to assist  
them in this vital task. Patients with congestive heart  
failure, for example, frequently suffer from chronic  
systemic edema, which must be controlled within tight  
limits to ensure adequate tissue perfusion and prevent  
25 dangerous electrolyte disturbances. Dehydration of

infants and children suffering from diarrhea can be life-threatening if not recognized and treated promptly.

The most common method for judging the severity of edema or dehydration is based on the interpretation of subjective clinical signs (e.g., swelling of limbs, dry mucous membranes), with additional information provided by measurements of the frequency of urination, heart rate, urea nitrogen (BUN)/creatinine ratios, and blood electrolyte levels and/or protein levels. None of these existing single-variable assessments, however, provide a means to easily determine water retention or loss.

#### SUMMARY

Therefore, there exists a need for methods and devices for monitoring body fluid, e.g., water, metrics that are less invasive, less subjective, and more accurate. The present disclosure, according to some specific example embodiments, relates to systems, devices, and/or methods for assessing body fluid-related metrics and changes therein. Other specific example embodiments, according to the present disclosure, further relate to systems, devices, and/or methods for correlating body fluid-related metrics, e.g., in a particular tissue with the corresponding whole-body metric.

The disclosure provides, according to some specific example embodiments, methods for assessing a whole-body water metric in a subject including (a) assessing a localized water metric at a tissue site in the subject using a probe, (b) acquiring tissue site location information, and (c) processing the localized water metric and the tissue site location information to

produce a whole-body water metric of the subject. The disclosure also provides specific example embodiments in which methods for assessing a whole-body water metric in a subject include (a) emitting light of at least one  
5 wavelength from a light source toward a tissue site, wherein a portion of the emitted light may be reflected by the tissue site, (b) detecting at least one wavelength of the light reflected by the tissue site with a detector positioned from about one millimeter to about five  
10 millimeters from the tissue site, (c) assessing the tissue site location, (d) processing the detected reflected light from the tissue site to determine a tissue site water metric, and (e) processing the tissue site water metric and the tissue site location to produce  
15 the whole-body water metric. According to some specific example embodiments, the disclosure further provides methods for diagnosing a water imbalance in a subject including (a) assessing a localized water metric at a tissue site in the subject using a probe, (b) acquiring  
20 tissue site location information, (c) processing the localized water metric and the tissue site location information to produce a whole-body water metric of the subject, and (d) comparing the whole-body water metric with a control and determining from that comparison  
25 whether the subject may be dehydrated or over-hydrated.

The disclosure additionally provides systems and/or devices for assessing a whole body fluid metric in a subject including a local fluid content probe configured to assess a local fluid metric at a tissue site, a  
30 location information sensor configured to assess location information of the probe, the tissue site, or the probe

and the tissue site, and a processor, wherein the processor may be operably coupled to the local fluid content probe, operably coupled to the location information sensor, and configured to process the local fluid content metric at the tissue site and location information to produce a whole-body fluid content metric. In other specific example embodiments, systems and/or devices for assessing a body fluid metric in a subject may include a probe housing configured to be placed proximal to a tissue site, a probe manipulator detachably connected to the probe housing and configured to place the probe housing proximal to the tissue site, light emission optics connected to the probe housing and configured to deliver radiation of at least one wavelength to the tissue site, light detection optics connected to the probe housing and configured to receive at least one wavelength of radiation from the tissue site, a location information sensor configured to detect location information for the probe housing, location information for the tissue site, or combinations thereof, and a processing device configured to process radiation from the light emission optics, radiation from the light detection optics, and location information from the location information sensor to produce a whole-body fluid metric. In some specific example embodiments of the disclosure, systems and/or devices may include a means for assessing a local fluid content metric at a tissue site of interest, a means for assessing a local fluid content metric at a tissue reference site, a means for processing a local fluid content at a tissue site of

interest and a local fluid content at a tissue reference site to produce a whole-body fluid content metric.

According to some specific example embodiments of the disclosure, probes for assessing a fluid content  
5 metric may include a probe housing configured to be placed proximal to a tissue site, a near infrared light emission fiber optic cable connected to the probe housing and configured to conduct radiation of at least one  
10 wavelength to the tissue site, a near infrared light detection fiber optic cable connected to the probe housing and configured to receive at least one wavelength of radiation from the tissue site, a location information sensor connected to the probe housing and configured to  
15 detect location information for at least a portion of the probe housing, location information for at least a portion of the tissue site, or combinations thereof, and at least one sterile surface.

#### BRIEF DESCRIPTION OF THE DRAWINGS

Some specific example embodiments of the disclosure  
20 may be understood by referring, in part, to the following description and the accompanying drawings, wherein:

FIGURE 1 is a bar graph of water content as a percentage of total mass and lean mass for men and women between the ages of 20 and 79.

25 FIGURE 2 is a bar graph of water content as a percentage of fat-free mass and fat-free-bone-free mass for men and women between the ages of 20 and 79.

FIGURE 3 is a graph of the correlation between separate fat-free or lean water fraction (" $f_w^L$ ")  
30 measurements on the same subject.

FIGURE 4A shows an isometric view of one example of a system with a disposable water probe in an engaged position according to the teachings of the present disclosure;

5       FIGURE 4B shows a cut-away view of the water assessment system of FIGURE 4A with the disposable water probe in a disengaged position;

10       FIGURE 5A shows an isometric view of one example of a system with a disposable water probe in an engaged position according to the teachings of the present disclosure;

FIGURE 5B shows a cut-away view of the system of FIGURE 5A with the disposable water probe in a disengaged position;

15       FIGURE 5C shows an isometric view of a variation of a system of FIGURE 5A in which the monitor is separate from the base unit and the disposable water probe is in contact with the mid-line of the torso of a subject;

20       FIGURE 6 shows the results of measuring lean water fraction ( $f_w'$ ) in tissue biopsies taken at different elevations.

FIGURE 7 shows the optical  $f_w'$  estimates with data gathered simultaneously with the tissue biopsies.

25       FIGURE 8 shows relationship between local and total body water fraction when fat is included ( $f_w$ ). The measurements were made in piglets (age: 1-3 months, body weight: 10-20 kg) that were being administered fluids (1L Lactated Ringer's Solution) intravenously in a series of 1 hour steps. Each fluid bolus was administered over a  
30   20 minute period followed by 40 minutes of equilibration before estimating the local and whole body water

fractions. Whole body water as a fraction of whole body mass ( $f_w$ ) was determined by chemical analysis of the homogenized carcass at the end of the experiment. By combining the weight of the animal during the experiment  
5 with the post-mortem body composition analysis, and assuming that changes in weight were solely due to changes in water content, the  $f_w$  could be determined at any point in the experiment. Tissue biopsies (5-8 mm in diameter and approximately 3 mm deep) were collected from  
10 sites across the belly and chest. For each data point displayed in the figures, the results of 3-9 biopsies were averaged, with careful effort to balance the number of biopsies taken from above the center of mass with the number of biopsies taken from below the center of mass.  
15 The same chemical analysis methods were used to perform the composition analysis of the whole carcass and local biopsy samples.

FIGURE 9 shows data from the same experiments as Figure 8, except with the local and total water computed  
20 as a fraction of lean mass ( $f_w^l$ ) rather than total mass ( $f_w$ ).

DETAILED DESCRIPTION

According to some specific example embodiments, systems, devices, and/or methods of the disclosure may be useful in assessing, monitoring, and/or adjusting fluid, e.g., water, status in a subject or in any portion of a subject. For example, various fluids, as well as diuretics, are commonly administered multiple times to patients in surgery or intensive care without assessing patient hydration. In the absence of such feedback, the patient may be exposed to a risk of inadequate or excessive systemic hydration. According to another specific example embodiment, the systems, devices, and/or methods of the disclosure may contribute to minimizing this risk through assessment of one or more body-fluid related metrics. According to a further specific example embodiment, the systems, devices, and/or methods of the disclosure may be applied to any tissue and/or region of the subject's body. Body-fluid metrics may be assessed in any multicellular organism and/or any portion of a multicellular organism. In some specific example embodiments, the subjects may be mammals (or other animals). In other specific example embodiments, mammalian subjects may be human.

Water may generally partition into one of two compartments in the body, namely, inside cells (the intracellular compartment) and outside of the cells (the extracellular compartment). The extracellular compartment is further divided into vascular and interstitial compartments. According to a yet further specific example embodiment, systems, devices, and/or methods of the disclosure may allow assessment of body-

fluid related metrics including, without limitation, (a) total water fraction ( $f_w^T$ ), (b) fat-free and/or lean tissue water fraction ( $f_w^L$ ), (c) intravascular water fraction ( $f_w^{IV}$ ), (d) extravascular water fraction ( $f_w^{EV}$ ),  
5 (e) interstitial water fraction ( $f_w^{IS}$ ), (f) intracellular water fraction ( $f_w^{IC}$ ), (g) extracellular water fraction ( $f_w^{EC}$ ), and/or (h) combinations thereof.

Several methods of quantitating fluid, e.g., water, in the body may be used in accordance with the teachings  
10 of the present disclosure including, without limitation, bioimpedance, transepidermal water loss, viscoelastic measurements, dielectric conductance, optical spectrophotometry, magnetic resonance, ultrasound, and/or combinations thereof. For example, bioimpedance analysis  
15 and/or bioelectrical impedance spectroscopy may be used to apply an electrical current to assess tissue conductivity and, thereby, obtain a local and/or systemic fluid metric.

Any tissue site of the subject's body may be  
20 assessed using the systems, devices, and/or methods of the disclosure. In some specific example embodiments, the fluid, e.g., water, content of a site at or near the surface of the skin may be assessed. In other specific example embodiments, the water content of localized  
25 tissue sites at the surface of or within an organ may be assessed. Organs that may be assessed include, without limitation, the brain, the eyes, the nose, the mouth, the esophagus, the stomach, the skin, the intestines, the liver, the gall bladder, the pancreas, the spleen, the  
30 heart, blood, the lungs, the kidneys, the liver, the vagina, the cervix, the uterus, the fallopian tubes, the

ovaries, the penis, the testes, the prostate, the bladder, and/or the pancreas. Tissues that may be assessed include, without limitation, muscles, bones, adipose, tendons, and/or ligaments.

5

### **Fluid Assessment**

According to some non-limiting specific example embodiments of the disclosure, a body-fluid metric may be assessed in a single tissue. Such single-site  
10 assessments may be combined with additional information to evaluate a subject's whole-body water status in terms of the same metric and/or another metric. For example, an assessment site may be chosen based on an empirical determination that its water status is closely correlated  
15 with a whole-body fluid metric. Such sites may include, without limitation, the midline of the torso of a subject lying on his or her side and the forehead of a subject whose heart is positioned below the forehead and the whole-body metric may be fat-free percent water. Other  
20 sites may also be utilized.

The disclosure also provides specific example embodiments in which a whole-body metric may be used as a proxy for a tissue-specific body-fluid metric based on a demonstrated, calculated, or estimated direct or  
25 proportional correlation. In one example, a whole-body fluid metric may be obtained and/or used to estimate and/or determine the corresponding local body fluid metric. A whole-body fluid metric, such as total interstitial volume, may also be used as a proxy for a  
30 different local metric, such as, e.g., local interstitial volume.

The method of diffuse reflectance or transmittance near-infrared ("NIR") spectroscopy may be employed to measure the fraction of fluid, e.g., water, in a tissue. An increase or decrease in the fluid, e.g., water, content of the skin produces unique alterations of its NIR reflectance spectrum in three primary bands of wavelengths (950-1400 nm, 1500-1800 nm, and 2000-2300 nm) in which non-heme proteins (primarily keratin, collagen, and elastin), lipids, hemoglobin, and water absorb.

The tissue water fraction,  $f_w$ , may be defined as the ratio of the concentration of water and the sum of the absorbances of water and other constituents of the tissue, or:

$$f_w = \frac{C_w}{C_T} \quad (1)$$

15

where  $C_w$  is the concentration of water and  $C_T$  is the concentration of a combination of tissue constituents. Concentration may be expressed, in some embodiments, in units of fractional weight, fractional volume, molarity, molarity or other units. As demonstrated by numerical simulations and experimental studies, the tissue water fraction may be measured in the presence of nonspecific scattering variation, temperature, and other interfering variables.

25

The concentrations of tissue constituents are computed by combining tissue reflectance (or transmittance) measured at different spectral wavelength. The absorbance of various constituents of tissue, other

than water, may be included in these measurements. For example, in one specific example embodiment, all of the other major tissue constituents, such as non-heme protein, lipid ("fat"), and hemoglobin, may be included, 5 resulting in the computation of the total tissue water fraction,  $f_w^T$ .

In other specific example embodiments, certain constituents of the tissue may be specifically excluded from the measured tissue water fraction. The disclosure 10 contemplates the use of any means of excluding a tissue constituent including, without limitation, spectroscopic methods, physical methods, and/or computational methods.

Non-limiting examples of spectroscopic methods for the exclusion of certain tissue constituents from the 15 computation of tissue water fraction are disclosed herein. In one type of specific example embodiment, spectral regions may be chosen where the absorbance contribution due to a selected tissue constituent may be small. For example, reflectance or transmittance may be 20 measured at wavelengths greater than approximately 1150 nm to reduce the influence of hemoglobin absorption. In another, the absorbance contribution due to a tissue constituent may be cancelled by appropriately combining spectroscopic measurements made at multiple wavelengths. 25 In the case of hemoglobin, reflectance or transmittance may be measured at wavelengths as short as 950 nm, but the influence of hemoglobin absorbance may be reduced by appropriately combining measurements of reflectance or transmittance at multiple wavelengths.

30 In some specific example embodiments, such spectroscopic methods may be used to exclude the

absorbance due to lipid from  $C_T$ . Doing so yields the fractional water in fat-free or lean tissue,  $f_w^L$ .

Non-limiting examples of physical methods for excluding certain tissue constituents include (a) exerting a force on the assessment site and (b) placing the source-detector in a defined position relative to the assessment site. The force applied to the assessment site may be a gravitational force. For example, an assessment site that is below the center of mass (e.g., an ankle) may contain mobile constituents. To reduce or eliminate mobile constituents from measurement, the subject may be, e.g., reoriented so that the assessment site is above the subject's center of mass (e.g., having the subject lie on a hospital bed and elevating the ankle above the heart). Without being limited to any mechanism of action, mobile tissue constituents may, in response to gravity, flow out of the assessment site when it is above the center of mass.

Force applied to the assessment site may also be pressure. In some specific example embodiments, fractional water may be measured before and after the application and/or release of pressure at the assessment site, allowing the mobile intravascular or interstitial portion of the tissue to be included or excluded from the measurement. Pressure may be applied to the assessment site by any means including, without limitation, using a compression weight, cuff, belt or other device. By appropriate application of pressure to the assessment site, it may be possible to assess the fractional water content in the intravascular space,  $f_w^{IV}$ , and/or the extravascular space,  $f_w^{EV}$  or the interstitial space or

intracellular space. In additional specific example embodiments, these measurements may be accomplished by photoplethysmography, e.g., by taking advantage of the natural arterial pulsation of blood through tissue.

5 Exclusion of the absorbance of some tissue constituents from the assessment may also be accomplished by selective placement of the source-detector relative to the assessment site. In some specific example  
10 embodiments, a source and a detector may be separated from each other by, about zero millimeters to about twenty millimeters (e.g., from about one millimeter to about five millimeters, or as much as 6.5 millimeters). However, depending on the site and the source-detector, other separation distances may be utilized. Separation  
15 may target the dermis while avoiding shallow penetration that would be indicative only of the stratum corneum layer of the skin. Separation may also avoid deep penetration into the underlying, high fat-content layer, or even further into bone-containing layers. To avoid  
20 shunting light through the superficial layers of the epidermis, the light source and/or detector may be configured to have low numerical apertures, e.g., less than about 0.3 radians. However, depending on the light source and/or detector, other apertures may be used.

25 Sensitivity of water fraction assessments to scattering variations may be minimized, if necessary, by, e.g., closely matching the optical path lengths through the dermis at the wavelengths at which the reflectances are measured. This matching may be achieved by judicious  
30 selection of wavelengths, e.g., wavelength sets, that have similar absorption scattering characteristics. Such

wavelengths and/or wavelength sets may be selected from any one of the three primary wavelength bands (950-1400 nm, 1500-1800 nm, and 2000-2300 nm) discussed above. Wavelengths, wavelength pairs, and/or sets may, according to some specific example embodiments, be chosen from within one of these three primary bands, rather than from across these bands. For example, the wavelength pair of 1180 and 1300 nm is a wavelength set wherein the lengths of the optical paths through the dermis at these wavelengths are matched as closely as possible. Within a band, wavelengths may be chosen, according to some specific example embodiments, that differ by from about one (1) nanometer up to about four hundred fifty (450) nanometers. For example, wavelengths within a band may be chosen that differ by about 5 nanometers, about 10 nanometers, about 15 nanometers, about 20 nanometers, about 25 nanometers, about 30 nanometers, about 35 nanometers, about 40 nanometers, about 45 nanometers, about 50 nanometers, about 55 nanometers, about 60 nanometers, about 65 nanometers, about 70 nanometers, about 75 nanometers, about 80 nanometers, about 85 nanometers, about 90 nanometers, about 95 nanometers, about 100 nanometers, about 105 nanometers, about 110 nanometers, about 115 nanometers, about 120 nanometers, about 125 nanometers, about 130 nanometers, about 135 nanometers, about 140 nanometers, about 145 nanometers, about 150 nanometers, about 155 nanometers, about 160 nanometers, about 165 nanometers, about 170 nanometers, about 175 nanometers, about 180 nanometers, about 185 nanometers, about 190 nanometers, about 195 nanometers, about 200 nanometers, or more than about 200 nanometers.

Absorption peaks of various biological tissue constituents may shift with variations in temperature. The sensitivity of water fraction assessments to temperature variations may be minimized by choosing the wavelengths at which the reflectances are measured to be close to temperature isosbestic wavelengths in the water absorption spectrum. For example, wavelengths may be selected at points in the absorption spectrum where no significant temperature shift occurs. Alternately, if the degree of the temperature shift is known or may be estimated, wavelength sets may be chosen such that any temperature shift may be mathematically canceled out when optical measurements are combined to compute the value of a tissue water metric. Such wavelength sets may be selected from any one of the three primary wavelength bands (950-1400 nm, 1500-1800 nm, and 2000-2300 nm) discussed above. Wavelengths, wavelength pairs, and/or sets may, according to some specific example embodiments, be chosen from within one of these three primary bands, rather than from across these bands. For example, the wavelength pair of 1195 and 1300 nm is one such pair of temperature isosbestic wavelengths in the water absorption spectrum.

The source of near infrared light may be configured to emit one or more wavelengths. The detector may be correspondingly configured to detect reflectance transmittance or absorption of one or more wavelengths. Reflectance data may be converted to absorption data according to the Equation (2):

30

$$A = \log [1/R(\lambda)], \quad (2)$$

where  $R$  is the reflectance at wavelength  $\lambda$ . When two or more wavelengths are emitted and detected, the measured reflectances transmittances may be combined to form a  
5 single ratio, a sum of ratios, a ratio of ratios of the form  $\log[R(\lambda_1)/R(\lambda_2)]$ , and/or a ratio of weighted sums of  $\log[R(\lambda)]$  terms, in which the numerator depends primarily on the absorbance of water, and the denominator depends primarily on the sum of the volume fractions of water,  
10 and other specific tissue constituents, such that the denominator is approximately equally sensitive to a change in the concentration of any of these specific constituents and water.

Thus, in one specific example embodiment of the present disclosure the water fraction,  $f_w$  may be estimated  
15 according to the following equation, based on the measurement of reflectances transmittances,  $R(\lambda)$  at two wavelengths and the empirically chosen calibration constants  $c_0$  and  $c_1$ :

20

$$f_w = c_1 \log[R(\lambda_1)/R(\lambda_2)] + c_0. \quad (3)$$

As demonstrated by numerical simulations and *in vitro* experiments, the total tissue water fraction,  $f_w^T$ ,  
25 may be estimated with an accuracy of approximately +/-2% over a range of water contents between 50 and 80% using Equation (3), with reflectances  $R(\lambda)$  measured at two wavelengths and the calibration constants  $c_0$  and  $c_1$  determined empirically. Examples of suitable wavelength

pairs include, but are not limited to, (a)  $\lambda_1=1300$  nm and  $\lambda_2=1168$  nm and (b)  $\lambda_1=1230$  nm and  $\lambda_2=1168$  nm.

The water fraction,  $f_w$ , may also be estimated according to Equation (4) below, based on the measurement of reflectances or transmittances,  $R(\lambda)$  at three wavelengths and the empirically determined calibration constants  $c_0$ ,  $c_1$  and  $c_2$ :

$$f_w = c_2 \log[R(\lambda_1)/R(\lambda_2)] + c_1 \log[R(\lambda_2)/R(\lambda_3)] + c_0. \quad (4)$$

10

Better absolute accuracy may be attained using Equation (4) which incorporates reflectance measurements at an additional wavelength. The results of *in vitro* experiments on excised skin indicate that the wavelength triple ( $\lambda_1=1190$  nm,  $\lambda_2=1170$  nm,  $\lambda_3=1274$  nm) yields accurate estimates of total tissue water content based on Equation (4).

According to some specific example embodiments, the water fraction,  $f_w$  may be estimated according to Equation (5) below, based on measurement of reflectances or transmittances,  $R(\lambda)$  at three wavelengths and the empirically determined calibration constants  $c_0$  and  $c_1$ :

20

$$f_w = c_1 \frac{\log[R(\lambda_1)/R(\lambda_2)]}{\log[R(\lambda_3)/R(\lambda_2)]} + c_0. \quad (5)$$

The accuracy of estimates obtained using Equation (5) may be better than those attained using Equation (4), which also incorporates reflectance measurements at an additional wavelength. Numerical simulations indicate

25

that total tissue water may be estimated to within +/- 0.5% using Equation (5), where reflectances are measured at three closely spaced wavelengths:  $\lambda_1=1710$  nm,  $\lambda_2=1730$  nm, and  $\lambda_3=1740$  nm. Additional numerical simulations indicate that accurate measurement of the lean tissue water content,  $f_w^L$ , may be accomplished using Equation (5), by combining reflectance measurements at 1125, 1185, and 1250 nm.

A tissue fluid monitor may provide a clinician with an indication of whether a patient requires more, less, or no fluid to achieve a desired state of hydration. Such a measurement may be less universally applicable than clinically desired when it is determined using an instrument that reports fractional water relative to either total body weight or total tissue content, due to the high variability of fat content across the human population. Fat contains very little water, so variations in the fractional fat content of the body lead directly to variations in the fractional water content of the body.

Gender and age-related differences in fat content reveal systematic variations in water content when averaged across many patients. This observation has been well-documented in the literature, as is shown for example in FIGURE 1. Values shown in FIGURE 1 have been computed from Tables II-III of Cohn et al., *J. Lab. Clin. Med.* (1985) 105(3), 305-311.

In contrast, when fat is excluded from the calculation, the fractional water content,  $f_w^L$ , in healthy subjects, may be consistent across both gender and age, as shown, for example, in FIGURES 1 and 2. This suggests

that  $f_w^L$ , may be a more clinically useful measurement than  $f_w$  for certain conditions. An additional reduction in the subject-to-subject variation in the "normal" level of fractional water content may be observed if bone mass is excluded from the calculation, as may be seen in FIGURE 2. This may be due to the fact that the bone content of the body tends to decrease with age (such as by osteoporosis). Thus, measurements of  $f_w^L$  in tissue made using the source-detector separation, wavelength band selection, or computational algorithms of the disclosure may be closely related to whole body water content as a fraction of the fat-free-bone-free body content.

Tissue water fraction,  $f_w$ , may also be estimated according to the following equation, based on measurement of reflectances,  $R(\lambda)$ , at a plurality of wavelengths:

$$f_w = \frac{\left[ \sum_{n=1}^N p_n \log\{R(\lambda_n)\} \right] - \left[ \sum_{n=1}^N p_n \right] \log\{R(\lambda_{N+1})\}}{\left[ \sum_{m=1}^M q_m \log\{R(\lambda_m)\} \right] - \left[ \sum_{m=1}^M q_m \right] \log\{R(\lambda_{M+1})\}}, \tag{6}$$

where  $p_n$  and  $q_m$  are calibration coefficients;  $R(\lambda)$  is a measure of received radiation at a wavelength; and  $n=1-N$  and  $m=1-M$  represent indexes for a plurality of wavelengths which may consist of the same or different combinations of wavelengths.

An obstacle to the quantification of tissue analytes may be the high subject-to-subject variability of the scattering coefficient of tissue. Determination of the fractional tissue water in accordance with Equation (6)

provides an advantage in that scattering variation may be cancelled, e.g., if the N+1 wavelengths are chosen from within the same wavelength band (950-1400 nm, 1500-1800 nm, or 2000-2300 nm). An explanation of the manner in which Equation (6) cancels scattering variations is provided below.

Tissue reflectance can be modeled according to a modified form of the Beer-Lambert equation:

$$\log[R(\lambda)] = -l(\lambda) \sum_{j=1}^J c_j \epsilon_j(\lambda) - \log\{I_0(\lambda)\}, \quad (7)$$

10

where:

R is the tissue reflectance;

l is the mean path length of light at wavelength  $\lambda$ ;

$\epsilon_j$  and  $c_j$  are the extinction coefficients and concentration of constituent j in the tissue; and

$\log\{I_0(\lambda)\}$  is a scattering offset term.

According to this model, the scattering dependence of tissue reflectance is due to the offset term,  $\log\{I_0(\lambda)\}$ , and the path length variation term,  $l(\lambda)$ . Since the scattering coefficient varies slowly with wavelength, by selecting all of the wavelengths from within the same wavelength band, the wavelength dependence of the scattering coefficient can be ignored to a good approximation. Under these conditions, by multiplying the log of the reflectance at wavelength N+1 (or M+1) by

25

the negative of the sum of the coefficients used to multiply the log of the reflectances at the N (or M) other wavelengths, the scattering offset terms are cancelled in both the numerator and denominator of Equation (6). This can be seen, for example, by substituting Equation (7) into the numerator of Equation (6) to obtain Equation (8):

$$\left[ \sum_{n=1}^N p_n \log \{R(\lambda_n)\} \right] - \left[ \sum_{n=1}^N p_n \right] \log \{R(\lambda_{N+1})\} = \quad (8)$$

$$-l \sum_{n=1}^N \left[ p_n \sum_{j=1}^J c_j \mathcal{E}_j(\lambda_n) \right] + l \left[ \sum_{n=1}^N p_n \right] \sum_{j=1}^J c_j \mathcal{E}_j(\lambda_{N+1}) .$$

10

A review of Equation (8) shows that the scattering offset term has been cancelled, but the scattering dependent path length variation term,  $l$ , remains. When the numerator and denominator of Equation (6) are combined, the path length variation term is also cancelled, as shown in Equation (9):

20

$$f_w = \frac{-\sum_{n=1}^N \left[ p_n \sum_{j=1}^J c_j \mathcal{E}_j(\lambda_n) \right] + \left[ \sum_{n=1}^N p_n \right] \sum_{j=1}^J c_j \mathcal{E}_j(\lambda_{N+1})}{-\sum_{m=1}^M \left[ q_m \sum_{j=1}^J c_j \mathcal{E}_j(\lambda_m) \right] + \left[ \sum_{m=1}^M q_m \right] \sum_{j=1}^J c_j \mathcal{E}_j(\lambda_{M+1})} . \quad (9)$$

Thus, Equation (9) depends on the concentrations and extinction coefficients of the constituents of tissue and on the calibration coefficients  $p_n$  and  $q_m$ .

In addition to providing for variable scattering  
5 compensation, the methods using Equation (6) may allow a more general implementation by relaxing some of the constraints that may be imposed by the use of Equation (5), above. For example, to provide a certain level of accuracy for measurement of  $f_w$ , the numerator in Equation  
10 (5) may need to be sensitive to changes in water concentration but insensitive to changes in all other tissue constituents. More specifically, Equation (5) may require that the absorbance of all tissue constituents besides water (e.g., lipid, non-heme protein, and/or  
15 hemoglobin) are nearly equal at wavelengths 1 and 2. This constraint may be removed in Equation (6), where the coefficients  $p_n$  are chosen to cancel out absorbance by all tissue constituents other than water.

In addition, to provide a certain level of accuracy  
20 for measurement of  $f_w$ , the denominator in Equation (5) may need to be equally sensitive to concentration changes of all tissue constituents to which the water fraction is to be normalized. In addition, Equation (5) may further require that the absorbance be equal at wavelengths 2 and  
25 3 for all tissue constituents to be excluded from the water fraction normalization. This constraint may be removed in Equation (6), where the coefficients,  $q_m$ , can be chosen to cancel the absorbance contribution due to certain constituents, while equalizing the absorbance  
30 sensitivity to the remaining tissue constituents.

For fat-free water fraction measurement, the coefficients,  $p_n$ , in the numerator of Equation (6) may be chosen to cancel the contribution from all of the major light-absorbing constituents of tissue, except water.

5 Similarly, the coefficients,  $q_m$ , in the denominator of Equation (6) may be chosen to cancel the contribution from all tissue constituents other than water and protein. In addition, the coefficients,  $q_m$ , may be chosen to equalize the sensitivity of the denominator to changes

10 in water and protein on a volume fractional basis. By computing the ratio of these two terms, the result is a fractional volume measurement of water concentration in lean tissue.

In addition, application of Equation (6) to the measurement of fractional water content in total tissue

15 volume,  $f_w^T$ , may be accomplished by choosing the coefficients in the denominator of Equation (6),  $q_m$ , so that all tissue constituents (including lipid) are equalized on a fractional volume basis.

20 By relaxing some of the constraints imposed by Equation (5), the use of Equation (6) may produce a more accurate prediction of fractional tissue water content, for the reasons set forth above. Various wavelength combinations may be used based on the criteria disclosed

25 above.

Extinction coefficients of water, non-heme protein, lipid, and hemoglobin were experimentally measured to select a wavelength combination for use with Equation (6) for measuring fractional water content in lean tissue,

30  $f_w^L$ . Real tissue data were collected from 37 different volunteers at a local hospital, with Institutional Review

Board (IRB) approval. The sensor measured reflected light from the pad of the finger, with a source-detector spacing of approximately 2.5 mm. The sensor was completely removed from the tissue between each pair of  
5 measurements.

Various wavelength combinations were applied to a numerical model of tissue absorbance. The reproducibility of the algorithms incorporating the most promising wavelength combinations were then compared with  
10 the real tissue data. An algorithm which combines measurements at 4 wavelengths, e.g., 1180, 1245, 1275, and 1330 nm may be utilized. Using this selection of wavelengths, the measurement-to-measurement reproducibility, as shown in FIGURE 3, is 0.37%,  
15 indicating high reproducibility of the tissue water measurements using the methods disclosed herein.

In addition to providing a method for measuring tissue water fraction, the method in accordance with Equation (6) above, may also have general utility for the  
20 fractional quantification of analytes in tissue. By appropriate choice of wavelengths and coefficients, Equation (6) may be extendible to the fractional concentration measurement of any tissue constituent or combination of constituents in tissue with respect to any  
25 other constituent or combination of constituents. For example, this equation also may be applicable for the determination of the fractional hemoglobin content in tissue.

Thus, according to one specific example embodiment,  
30 the present disclosure provides a method of assessing the fractional volume of total hemoglobin in tissue,

including measuring reflectance at wavelengths strongly absorbed by hemoglobin, measuring reflectance at wavelengths absorbed, e.g., strongly absorbed, by remaining tissue constituents (such as water, lipid, and/or non-protein), entering these measurements in Equation (6), and calculating the fractional volume of total hemoglobin in tissue. The coefficients,  $p_n$ , in the numerator of Equation (6) may be chosen to cancel the absorbance contributions from all tissue constituents except total hemoglobin. The coefficients,  $q_m$ , in the denominator of Equation (6) are chosen to equalize the absorbance contributions of all major tissue constituents, on a volume fractional basis. One example of a specific wavelength combination for accomplishing this measurement may be 805 nm, 1185 nm, and 1310 nm. At 805 nm the absorbance by the oxy- and deoxyhemoglobin are approximately equal. At 1185 nm, the absorbance of water, non-heme protein, and lipid, are nearly equal on a fractional volume basis. At 1300 nm the tissue absorbance may be dominated by water.

According to yet another specific example embodiment of the present disclosure, measurement of fractional concentrations of different species of hemoglobin in tissue may be performed. In general, the method provides a means of measuring the fractional concentration of hemoglobin in a first set comprised of one or more species of hemoglobin with respect to the concentration of hemoglobin in a second set comprised of one or more hemoglobin species in tissue. The coefficients,  $p_n$ , in the numerator of Equation (6) may be chosen to cancel the absorbance contributions from all tissue constituents

except the hemoglobin species included in set 1. The coefficients,  $q_m$ , in the denominator of Equation (6) may be chosen to equalize the absorbance contributions from all tissue constituents except the hemoglobin species  
5 included in set 2. Sets 1 and 2 are subsets of hemoglobin species that are present in the body tissue or blood. For example, such hemoglobin species include oxyhemoglobin, deoxyhemoglobin, carboxyhemoglobin, methemoglobin, sulfhemoglobin and, so on. And in  
10 general, as used herein, other physiological parameters have other subsets of constituents each being capable of absorbing at different wavelengths. When set 1 is comprised of oxyhemoglobin and set 2 is comprised of oxy- and deoxyhemoglobin, an example of a specific wavelength  
15 combination for accomplishing the measurement may be 735, 760, and 805 nm.

Individuals of ordinary skill in the art will recognize that additional terms may be added to Equations (3)-(6) with the guidelines of the present disclosure.  
20 These additional terms may be used to incorporate reflectance measurements made at additional wavelengths and, thus, e.g., possibly further improve accuracy.

According to an additional specific example embodiment, the disclosure provides methods for  
25 quantitative assessment of fluid shifts into and/or out of the bloodstream using spectrophotometry. Without being limited to any particular mechanism of action, this specific example embodiment recognizes that pulsations caused by expansion of blood vessels in the skin as the  
30 heart beats produce changes in the reflectance at a particular wavelength. These changes may be proportional

to the difference between the effective absorption of light in the blood and the surrounding interstitial tissues. Numerical simulations indicate that, if wavelengths are chosen at which water absorption is sufficiently strong, the difference between the fractions of water in the blood,  $f_w^{IV}$  and surrounding tissue,  $f_w^{EV}$  may be proportional to the ratio of the dc-normalized reflectance changes ( $\Delta R/R$ ) measured at two wavelengths, according to Equation (10) below:

10

$$f_w^{EV} - f_w^{IV} = c_1 \frac{(\Delta R/R)\lambda_1}{(\Delta R/R)\lambda_2} + c_0. \quad (10)$$

15

where  $c_0$  and  $c_1$  are empirically-determined calibration constants. This difference, integrated over time, provides a measure of the quantity of fluid that shifts into and/or out of the capillaries.

Some specific example embodiments of the disclosure provide methods of assessing a water balance index,  $Q$ , using Equation (11):

20

$$Q = \frac{f_w^{IV} - f_w^{EV}}{f_h^{IV}} = a_1 \frac{(\Delta R/R)\lambda_1}{(\Delta R/R)\lambda_2} + a_0, \quad (11)$$

25 wherein

$f_h^{IV}$  is the fractional volume concentration of hemoglobin in the blood; and  $a_0$  and  $a_1$  are calibration coefficients.

The use of Equation (11) to determine a water balance may be similar to using Equation (10) above, where  $f_h^{IV}$  is set equal to 1. However, using Equation (10) may yield a more accurate determination by not neglecting the influence of  $f_h^{IV}$  on the derived result. The effect of this omission may be understood by allowing total hemoglobin to vary over the normal physiological range and computing the difference between the results provided by Equation (10) when  $f_h^{IV}$  is fixed or allowed to vary. For example, when calculations were performed with  $f_w^{IV}$  varying between 0.75 and 0.80 and  $f_h^{IV}$  varying between 0.09 and 0.135, the resulting error was as large as +/- 20%. In situations of extreme blood loss or vascular fluid overload (hypo- or hypervolemia), the error may be larger.

The index provided by Equation (10) may have clinical utility without further manipulation. For example, simultaneous measurement of both  $Q$  and fractional tissue water (either  $f_w$  or  $f_w^L$ ) may directly and/or indirectly provide a clinical indication of changes in both volume and osmolarity of body fluids. Alternatively, the index ( $Q$ ) may be combined with a separate measurement of fractional hemoglobin concentration in blood,  $f_h^{IV}$ , (such as may be provided by standard clinical measurements of hematocrit or total hemoglobin) to provide a measure of the difference

between the intravascular and extravascular water content,  $f_w^{IV} - f_w^{EV}$ .

Table 1 lists 6 examples of combinations of volume and osmolarity changes in body fluids that are clinically observed (from Physiology, 2<sup>nd</sup> Edition, Linda S. Costanzo, Williams and Wilkins, Baltimore, 1998, pg. 156), and the expected direction and magnitude of the resultant change in fractional volume of water in blood ( $f_w^{IV}$ ), the fractional volume of water in tissue ( $f_w^{EV}$ ), the fractional volume of hemoglobin in blood ( $f_h^{IV}$ ), the numerator of Q ( $Q_n$ ), the inverse of the denominator of Q ( $1/Q_d$ ), the combined result ( $Q_n/Q_d=Q$ ), and the fractional volume of water in lean tissue,  $f_w^L$ .

For example, is-osmotic volume expansion (e.g., expansion induced by infusion with isotonic saline) may result in an increase in the fraction of water in blood ( $f_w^{IV}$ ), a small increase in the extravascular water fraction ( $f_w^{EV}$ ), and/or a large decrease in the fractional concentration of hemoglobin in the blood ( $f_h^{IV}$ ). The combined effect of these 3 factors would result in a large increase in Q. A small increase in the fraction of water in the lean tissue,  $f_w^L$ , would also be expected.

When Q and  $f_w^L$  are viewed in combination, they provide unique signatures for each of the 6 types of fluid balance change listed in Table 1. An instrument providing these measurements in a non-invasive and/or continuous fashion provides a powerful tool for the monitoring of tissue water balance.

TABLE 1: Expected Changes in  $Q$  and  $f_w^L$  Resulting from Changes in Body Fluid Volume and Osmolarity

Type	Example	$f_w^{IV}$	$f_w^{EV}$	$f_h^{IV}$	$Q_n$	$1/Q_d$	$Q$	$f_w^L$
Isosmotic volume expansion	Isotonic NaCl Infusion	↑	↑	↓	↑	↑	↑	↑
Isosmotic volume contraction	Diarrhea	↓	↓	↑	↓	↓	↓	↓
Hyperosmotic volume expansion	High NaCl intake	↑	↑	↓	↑	↑	↑	↑
Hyperosmotic volume contraction	Sweating, Fever	↓	↓	↑	0	↓	↓	↓
Hypo-osmotic volume contraction	SIADH	↑	↑	↓	0	↑	↑	↑
Hypo-osmotic volume contraction	Adrenal Insufficiency	↓	↓	↑	↓	↓	↓	↓

### Extracellular Fluid Assessment

Water may move from one compartment to another. For example, extracellular water may move from place to place within the body in response to gravity or hydrostatic pressure. In addition, water content may change independently in the intracellular, interstitial, and/or vascular compartments, with different implications for fluid management. For instance, an overload of interstitial water may lead to water in the lungs, impairing gas exchange. Of the two extravascular compartments, the interstitial volume may be about three times greater than the vascular volume. In view of some dynamics of water movement, measurement of water in a single tissue or compartment may not correlate well with total body water. For example, lean water fraction ( $f_w'$ ) measurements may read high relative to whole-body  $f_w'$  if the sensor is on a site that is significantly below the heart and/or, reciprocally, may read low if the sensor is on a site that is significantly above the heart.

Therefore, the present disclosure provides, in some specific example embodiments, methods for accounting for and/or assessing such mobile constituents. For example, a body-fluid metric may be assessed by determining the difference between the lean water fraction of a tissue of interest and a reference tissue. A reference tissue may be the same tissue under a different hydrostatic pressure or a different tissue. For example, a single sensor may be placed in a single tissue and a body fluid, e.g., water, metric assessed. Then the hydrostatic condition of the location may be changed before a second assessment of the body fluid-related metric. To minimize unstable

or artifactual readings, the tissue may be given time to re-equilibrate before assessing the same site a second time.

The hydrostatic condition of an assessment site may be changed by any means available in the art. For example, the hydrostatic condition may be altered, e.g., by changing the position of the site relative to the rest of the body, such as, e.g., by raising or lowering the sampling location relative to the subject's heart. Alternatively, the hydrostatic condition may be altered by increasing or reducing the ambient external pressure on a location. This may be accomplished, e.g., by applying pressure to a site during the first or second assessment using a tissue compressor, e.g., compression weight, cuff, belt or pressure chamber.

Thus, some specific example embodiments of the present disclosure relate to a method for evaluating changes in extracellular fluid volume, including: (a) measuring optical signals, e.g., sets of optical signals, at one or more wavelengths, received by at least one optical detector from at least one light source at an assessment site or sites having a first hydrostatic pressure; (b) measuring optical signals, e.g., sets of optical signals, at one or more wavelengths, received by at least one optical detector from at least one light source at a tissue site or sites having a second hydrostatic pressure; (c) estimating fluid content, e.g., water content, from said optical signals acquired from said site and/or sites having said hydrostatic pressures; and (d) determining the relationship of said water-content estimates to the differences in hydrostatic

pressure and estimating changes in extracellular fluid volume based on said relationship.

In some specific example embodiments, the amount of extracellular water in a tissue may be assessed by determining the difference between the lean water fraction of that tissue and a reference tissue. The reference tissue may be the same tissue under different hydrostatic or gravitational pressure. For example, extracellular water may be expressed as a fraction of the total water present (e.g., a sum of intracellular and extracellular water) as shown in Equation (13):

$$f_w^{EC} = \frac{C_w^{EC}}{C_w^{IC} + C_w^{EC}} \quad (13)$$

wherein

$C_w^{IC}$  is the concentration of intracellular water; and  
 $C_w^{EC}$  is the concentration of extracellular water.

Thus, where

$$Z = \left[ \sum_{n=1}^N p_n \log\{R(\lambda_n)\} \right] - \left[ \sum_{n=1}^N p_n \right] \log\{R(\lambda_{N+1})\} \quad (14)$$

with terms defined as in Equation 6, extracellular water may be assessed by measuring Z at equilibrium ( $Z_{eq}$ ), measuring Z under pressure ( $Z_p$ ), and computing  $f_w^{EC}$  according to Equation 15:

$$f_w^{EC} = 1 - \frac{Z_p}{Z_{eq}} \quad (15)$$

Equation 15 may apply where the coefficients,  $p_n$ , or  $Z$  are chosen to cancel out absorbance by all tissue constituents other than water. In some specific example embodiments, assessment of a fraction of extracellular water relative to total water in a sampled volume may provide a direct assessment of edema in the effected volume. Reflectance measurements in several regions of the spectrum may be mathematically combined in some embodiments so that the contributions due to all constituents except water are cancelled. Measurements may be performed before and after application of pressure at a tissue site. By computing a ratio of results with and without applied pressure, an extracellular water fraction may be estimated.

The extracellular water fraction may also be equal to the change in total water fraction. Measurements of extracellular water may be obtained by raising the pressure at the site until no further changes in the total or lean water fraction are observed. The total or lean water fraction value at this peak pressure may be substantially equal to the intracellular water fraction. If the residual water is not negligible in a particular tissue, a constant may be used to correct for the small amount of remaining extracellular water. Such a constant may be chosen or empirically-determined by those of ordinary skill in the art.

The reference tissue, alternatively, may be a different tissue site ("S<sub>ref</sub>"). The site of interest and the reference site may be independently chosen. In some specific example embodiments of the disclosure,

5 assessments at each location may be made at different times, at about the same time, and/or at the same time. The reference tissue may be within the same or similar tissue or organ or may be within a different tissue or organ. In some specific example embodiments, the

10 reference tissue may be in hydrostatic contact with the site of interest ("S<sub>i</sub>"), such that mobile extracellular water may move between the two. If the extracellular water at the site of interest moves into the reference site upon the application of pressure, the change in the

15 total water fraction or lean water fraction at the reference site may be correlated with the resting extracellular water content at the site of interest ( $f_{w(S_i)}^{EC(eq)}$ ). If the amount of pressure applied at the site of interest is increased until no further changes in

20 total water at the reference site are observed, the extracellular water at the site of interest may be assessed using Equation (16):

$$f_{w(S_i)}^{EC(eq)} = e_0 \left[ 1 - \frac{Z_p}{Z_{eq}} \right], \quad (16)$$

25 wherein

$e_0$  is a correlation constant;

The correlation constant may have a value of one (1) when all of the water that moves out of the site of interest moves into the reference site. If less than the entire

amount of extracellular water at the site of interest moves into the reference site, the value of  $e_0$  will be greater than one and may be calculated and/or empirically-determined. This may be the case when, for  
5 example, mechanical pressure affects the flow of water out of the tissue site of interest and/or into the reference site. In specific example embodiments where the extracellular water at the site of interest moves radially into adjacent tissue upon the application of  
10 pressure, the correlation constant may be a function of the radial distance from the site of interest to the reference site. If the size and/or shape of the area into which the extracellular water moves is unknown, a grid centered on the site of interest may be drawn and  
15 total or lean water measurements made in each section as pressure is increased.

According to some non-limiting specific example embodiments, the reference site need not be in hydrostatic contact with the site of interest. For  
20 example, water may not directly move between a site of interest and a reference site when the water status of one may be communicated to and impacts the water status of the other site via hormonal, electrical, and/or other signals. In some specific example embodiments, there may  
25 be no connection between the tissue site of interest and the reference site.

Accumulation of extracellular water may be monitored for diagnostic or therapeutic purposes. For example, an excessive amount of extracellular water in a tissue may  
30 increase the presence of edema in that tissue. A subject confined to a bed for an extended period of time may

accumulate extracellular water in tissues at or near the surface of the bed. Extracellular water accumulation may be monitored by periodically measuring the total and/or lean water content of a tissue above the subject's center of mass, periodically measuring the total and/or lean water content of a tissue below the subject's center of mass, and calculating the difference between the two. Over time, gravity may drain extracellular water from the upper tissues into the lower tissues. Extracellular water at the lower site ( $S_{low}$ ) may be estimated using Equation 17:

$$f_{w(S_{low})}^{EC} = k_0 \left[ 1 - \frac{Z_p}{Z_{eq}} \right] \quad (17)$$

wherein

$k_0$  is a correlation constant;  
The correlation constant ( $k_0$ ) may be empirically determined and may correct for incomplete drainage from  $S_{up}$  to  $S_{low}$ . Extracellular water may be a useful metric for determining when to turn over a subject who is partially or completely immobile (e.g., a coma patient) to reduce or prevent bed sores or infections. Thus, when the extracellular water content of the upper tissue falls below a given threshold or the content of the lower tissue exceeds a given threshold, the subject may be moved to redistribute the extracellular water.

According to some specific example embodiments, the disclosure provides methods of assessing the extracellular water in tissue that may be diseased and/or damaged. In such tissue, there may be a risk that

application of pressure would aggravate the already poor condition of the tissue. Two or more detectors may be placed around the site of interest. The site of interest may be placed in a pre-selected position relative to the heart or the whole-body center of mass. Alternatively, if the site of interest is in an extremity, it may be positioned relative to the center of mass of that extremity. Positioning relative to a mass or circulatory reference point may be performed to minimize changes in hydrostatic pressure at the site of interest. A water metric may then be assessed at the site of interest by measuring the water metric at the reference site(s) where detectors may be located, processing this information together with the position of the site of interest relative to the detectors, heart, and/or center of mass, and calculating the metric at the site of interest. The water fraction at any of the detector sites, the change in fractional water between sites, and/or the rate of change in fractional water between sites may be used alone or in combination to assess water status of the diseased and/or damaged tissue. By placing an array of detectors at varying distances from the trauma site and assessing a body-fluid metric at each, it may be possible to determine whether and/or how much fluid is being lost or gained through a wound site. In some of these embodiments, it may be desirable to take precautions against contaminating the site. For example, a water probe and/or detector may further comprise at least one sanitized and/or sterilized surface proximal to a portion of the probe and/or detector that may be expected to be in close proximity to the site.

**Fluid Assessment with Location Information**

Additional specific example embodiments of the disclosure are provided in which a single-site fluid metric assessment may be combined with site location information to calculate or estimate the corresponding whole-body fluid metric. The location of the assessment site may be directly and/or indirectly detected or determined. Alternatively, the location of the device used to assess the body fluid metric (the "water probe") may be used. Location information may include the position, orientation, and/or elevation of the assessment site and/or the water probe relative to the subject's center of mass and/or some other bodily reference point.

Location information may also include position, orientation, and/or elevation of the assessment site and/or of the water probe relative to any reference point such as, e.g., the subject's bed, the ground, the gravitational vector, and/or combinations thereof.

Location information may be assessed using an water probe location sensor. Location information may be used to determine (a) a multiplier (e.g., a correlation constant) and/or (b) an operation to perform on the single-site data to produce the corresponding whole-body metric.

One of ordinary skill in the art will recognize that multiple means for sensing position, orientation, and/or elevation changes are readily available. For example, orientation sensors may be used that are like sensors integrated into flat-panel displays, including those of handheld medical monitors, for the purpose of switching the display from portrait to landscape mode. Means of

determining elevation changes relative to the heart might include settings on the surgical table or hospital bed, a camera, a small tube with fluid and a pressure sensor at one end. In addition, an water probe location sensor  
5 according to some specific example embodiments of the disclosure may include one or more mechanical linkages, such as, e.g., an arm with a joint, that attaches to a probe. In these cases, the position and/or orientation of a probe may be ascertained from the length of the arm,  
10 the angle of its joint, and/or the position of the subject. Remote water probe location sensors may also provide location information relative to the subject's body, such as, e.g., where a sensor uses optical and/or ultrasound emitters (e.g., on the probe, subject, and/or  
15 hospital bed) and detectors (e.g., on the sensor). Alternatively, a sensor may include a video camera and/or may use object recognition image processing software to detect probe location and/or tissue site position, orientation, and/or elevation. In yet another example, a  
20 sensor may also receive signals from one or more small piezoelectric vibratory gyroscopes located in a probe. These may be the same types of gyroscopes that may be used in automobile navigation systems and may allow detection of probe location information.

25 According to a specific example embodiment of the present disclosure, a water probe and a water probe location sensor may be in direct contact, e.g. physical contact, such that probe and sensor may be integrated into a single unit. If so, location information may be  
30 assessed with reference to external points, e.g., the subject's hospital bed, the floor, and/or the walls.

Emitters and/or detectors may be placed in these external locations as needed. According to another specific example embodiment of the disclosure, probes and sensors may also be physically connected by an arm, cable, and/or other linker. Alternatively, probes and sensors may lack any direct connection. Where a probe and a sensor are discontiguous, each may be configured to exchange signals with the other, send signals to a display, send signals to a remote processor, and/or combinations thereof.

Thus, the present disclosure contemplates detecting a location of a probe and/or compensating for overly high or low body-fluid metrics assessed in, e.g., a tissue. Determining the nature and/or magnitude of that compensation may include collection and/or analysis of data from human volunteers placed in various positions for reasonable lengths of time with sensors at tissue sites. Accordingly, the disclosure further provides specific example embodiments wherein a database of body-fluid metric data from a variety of body locations with the body in a variety of positions may be compiled in relation to an individual and/or population. The total body water metric in an individual, according to a specific example embodiment of the disclosure, may then be assessed by detecting a body-fluid metric at an assessment site, identifying the location of the assessment site on the body, identifying the location of the assessment site relative to a center of mass and/or circulatory reference point, and/or correlating the local body-fluid metric and/or location data with the corresponding whole body-fluid metric.

### Systems and Devices

In some specific example embodiments, the present disclosure provides systems and devices for measuring a body-tissue fluid content metric, e.g., water content.

5 Systems and/or devices for assessing whole-body water content of a subject may include a local water content probe (e.g., a water probe) configured to assess a local fluid metric at a tissue site (e.g., a tissue site of interest and/or a tissue reference site). A system, 10 device, and/or probe of the disclosure may include, in some embodiments; a reflectance standard (e.g., a teflon block) to calibrate out the wavelength response or sensitivity or emissivity of tissue site emitters and/or detectors. A system and/or device of the disclosure may 15 include, in some embodiments, a probe receiver configured to contact an area at or near a tissue site and configured to releasably engage a probe and/or probe housing. For example, a probe receiver may include an toroidally-shaped adhesive pad that encircles a tissue 20 site when positioned on a subject and receives a probe or probe housing into its center space.

Systems and/or devices of the disclosure may also include a tissue compressor configured to alter (e.g., increase or decrease) the hydrostatic pressure of an 25 assessment site and/or a reference site. Systems and/or devices of the disclosure may further include a probe location information sensor configured to determine location information of a probe and/or an assessment site. Systems and/or devices according to the disclosure 30 may further include a processor, e.g., a processing device, configured to process a local fluid content

metric at a tissue site of interest and a local fluid content metric at a tissue reference site to produce a whole-body fluid content metric. In other specific example embodiments, systems and/or devices according to the disclosure may further include a processor, e.g., a processing device, configured to process a local fluid content metric and probe location information to produce a whole-body fluid content metric. According to some specific example embodiments, at least a portion of a system or device of the disclosure may be configured to be sterile, sanitizable, disposable, replaceable, and/or repairable. In other specific example embodiments, at least a portion of a system and/or device, e.g., a probe, may be covered with a disposable cover. For example, a probe may be covered in whole or in part by a hygienic cover similar to those used with infrared ear thermometers.

Systems and/or devices of the disclosure may be configured to assess a local fluid metric by any means available including, without limitation, bioimpedance, transepidermal water loss, viscoelastic measurements, optical spectrophotometry, magnetic resonance, ultrasound, and/or combinations thereof. For example, bioimpedance analysis and/or bioelectrical impedance spectroscopy may be used to apply an electrical current to assess tissue conductivity and, thereby, obtain a local fluid metric. It may be based, at least in part, on the different conductive and dielectric properties of various biological tissues at various biological tissues at various frequencies of current. An applied electrical current may follow a path of least resistance. In

tissues a path of least resistance may be extra-cellular fluid or cells themselves depending on their conductivity, *e.g.*, blood, muscle, and/or other fat free tissues.

5           For example, the disclosure provides systems, devices, and/or methods for assessing a whole body fluid metric using bioimpedance analysis and/or bioelectrical impedance spectroscopy. In one specific example embodiment, a method for assessing a whole body fluid  
10           metric may include applying an electrical current to a tissue site, assessing the tissue site conductivity, obtaining tissue site location information, and processing the tissue site conductivity and location information to produce a whole body fluid metric.

15           Assessing tissue site conductivity may include contacting at least a portion of a subject with two or more electrical contacts, applying a known current at one or more frequencies through the at least two electrical contacts and measuring impedance between the at least two  
20           electrical contacts.

          The disclosure also provides, in some specific example embodiments, a system and/or device for assessing a whole body fluid metric. The system may include a disposable bioimpedance water probe, a processing device  
25           (*e.g.*, a processor), and/or a location sensor. The system may further include a power source (*e.g.*, an alternating current source), one or more controls (*e.g.*, a rheostat), and/or one or more safety mechanisms (*e.g.*, a current governor). A bioimpedance water probe may  
30           include two or more electrical contacts configured for

electrically contacting and applying a current to at least a portion of a subject.

In addition, systems and/or devices may be designed to make measurements using optical spectrophotometry. A device may include a probe housing configured to be placed near and/or at an assessment site; light emission optics connected to the housing and configured to direct radiation at the assessment site; and/or light detection optics connected to the housing and configured to receive radiation from the assessment site. A system may include a probe housing configured to be placed near and/or at an assessment site; light emission optics connected to the housing and configured to direct radiation at the assessment site; light detection optics connected to the housing and configured to receive radiation from the assessment site; a processing device, e.g., a processor, configured to process radiation from the light emission optics and the light detection optics to compute the metric; and/or a display on which raw data and/or the body-fluid metric may be displayed. The display may be operably coupled to light emission optics, light detection optics, and/or a processor. A device, e.g., a probe housing, may include a pressure transducer to assess the compressibility of tissue for deriving an index of a fraction of free water within said tissue.

According to some specific example embodiments, systems and/or devices may include a light source capable of emitting electromagnetic radiation of at least one wavelength. For example, systems and/or devices may include a light source that emits a broad or narrow band of wavelengths of infrared, visible, and/or ultraviolet

light. The light source may also emit fluorescent or phosphorescent light. A light source may emit light continuously, intermittently and/or sporadically. In some specific example embodiments, systems and/or devices  
5 may include any additional spectrophotometry components including, without limitation, one or more modulators, polarizers, rhombs, etalons, prisms, windows, gratings, slits, interferometers, lenses, mirrors, reflective phase retarders, wavelength selectors, waveguides, beam  
10 expanders, beam splitters, and/or photodetectors.

Some specific example embodiments of the disclosure may be understood by reference, in part, to FIGURES 4A-5C, wherein like numbers refer to same and like parts. These figures are illustrative only and are not intended  
15 to limit the possible sizes, shapes, proportions, and/or relative arrangements of various specific example embodiments. Table 2 lists reference numerals with their associated names and figures in which they appear.

In the non-limiting specific example embodiment shown in FIGURES 4A-4B, system 10 may include system  
20 housing 15, light emission optics 20, light detection optics 30, processor 40, display 45, disposable water probe 50, and water probe location sensor 55. Light emission optics 20 may include light emission aperture  
25 21, disposable fiber optic cable 22, fiber optic cable connector 23, fiber optic cable 24, and light source 25. Light detection optics 30 may include light detection aperture 31, disposable fiber optic cable 32, fiber optic cable connector 33, fiber optic cable 34, and light  
30 detector 35.

Radiation may be conveyed by light emission optics 20 to the tissue site. For example, light emission optics 20 may be configured such that up to the entire amount of radiation emitted by light source 25 enters fiber optic cable 24, passes through fiber optic cable connector 23, disposable fiber optic cable 22, and aperture 21, and contacts the tissue site. Similarly, radiation may be conveyed by light detection optics 30 from the tissue site to light detector 35. For example, light detection optics 30 may be configured such that up to the full amount of radiation reflected, scattered, and/or transmitted by a tissue site may enter light detection aperture 31 and pass through disposable fiber optic cable 32, fiber optic cable connector 33, and fiber optic cable 34 and contact at least a portion of light detector 35.

System 10 may also include components (now shown) for dispersing a broad band source into constituent wavelength, e.g. a prism, grating, interferometer, band-pass filters, tunable filters.

Detector 35 may be configured to detect the amount and/or wavelength(s) of light received from a tissue site. Light detector 35 may deliver a signal corresponding to the light detected to operably coupled processor 40. Light emission optics 20 may be configured to deliver to processor 40 a signal corresponding to the amount and/or wavelength of light delivered to the tissue site. Processor 40 may be configured to perform one or more mathematical operations on the signals received. Processor 40 may further be configured to deliver to display 45 a signal corresponding to mathematical

operation(s) performed, data used in performing mathematical operation(s), and/or results of the mathematical operation(s). Display 45 may also receive from any system component signals corresponding to the amount and/or wavelength of light (a) emitted by light source 25, (b) delivered to the tissue site by light emission optics 20, (c) received by light detection optics 30, and/or (d) detected by detector 35.

System 10 may also include water probe location sensor 55. Sensor 55 may be configured to detect and/or receive location information. Location information may include the location and/or orientation of at least a portion of system 10, the location and/or orientation of the site of assessment, and/or the location and/or orientation of a reference point. Sensor 55 also may be configured to deliver a signal corresponding to location information to processor 40.

Disposable water probe 50 may include aperture 21, disposable fiber optic cable 22, fiber optic cable connector 23, aperture 31, disposable fiber optic cable 32, fiber optic cable connector 33, disposable water probe housing 51, spacer 52, and/or seal 53. Spacer 52 may be a separate component of probe 50. Alternatively, it may be formed simply by extending the walls of probe housing 51 a desirable distance beyond light emission aperture and/or light detection aperture.

Disposable water probe 50 may be configured to be replaced, reconditioned, repaired, sanitized, and/or sterilized between each use. Disposable water probe 50 may also be configured to contact a subject at or near seal 53. Seal 53 may be configured to create a light-

tight seal between probe housing 51 and a tissue site. In this context, light-tight means that up to all extraneous light is excluded from the tissue site to permit detection of at least a portion of the light source light reflected, scattered, absorbed, and/or transmitted by the tissue site.

According to the specific example embodiment shown in FIGURE 5A, system 110 may include base unit 111, optical fiber bundle 118, disposable water probe 150, and reusable water probe manipulator 160. Base unit 111 may include housing 115, controller 116, power inlet or power source 117, optical fiber bundle 118, optical fiber bundle housing 119, at least a portion of fiber optic cable 124, light source 125, at least a portion of fiber optic cable 134, light detector 135, and processor 140 as shown in FIGURE 5B. Base unit 111 may further include display 145 as an integral or separate component as shown respectively in FIGURES 5B and 5C. Base unit 111 may additionally include a user input such as, e.g., keyboard 112, as shown in FIGURE 5C.

Base unit 111 may be connected to disposable water probe 150 by reusable water probe manipulator 160 and optical fiber bundle 118. The length of optical fiber bundle 118 may be selected in accordance with the use contemplated, the strength of the light source, the presence and size of apertures, the transmittance of fiber optic cables, and/or the sensitivity of the detector.

Light emission optics 120 may include light emission aperture 121, disposable fiber optic cable 122, fiber optic cable connector 123, fiber optic cable 124, and

light source 125. Light detection optics 130 may include light detection aperture 131, disposable fiber optic cable 132, fiber optic cable connector 133, fiber optic cable 134, and light detector 135.

5 System 110 may also include components (now shown) for dispersing a broad band source into constituent wavelength, e.g. a prism, grating, interferometer, band-pass filters, tunable filters.

Radiation may be conveyed by light emission optics  
10 120 to the tissue site. For example, light emission optics 120 may be configured such that up to the entire amount of radiation emitted by light source 125 enters fiber optic cable 124, passes through fiber optic cable connector 123, disposable fiber optic cable 122, and  
15 aperture 121, and contacts the tissue site. Similarly, radiation may be conveyed by light detection optics 130 from the tissue site to light detector 135. For example, light detection optics 130 may be configured such that up to the full amount of radiation reflected, scattered,  
20 and/or transmitted by a tissue site may enter light detection aperture 131 and pass through disposable fiber optic cable 132, fiber optic cable connector 133, and fiber optic cable 134 and contact at least a portion of light detector 135.

25 Detector 135 may be configured to detect the amount and/or wavelength(s) of light received from a tissue site. Light detector 135 may deliver a signal corresponding to the light detected to operably coupled processor 140. Light emission optics 120 may be  
30 configured to deliver to processor 140 a signal corresponding to the amount and/or wavelength of light

delivered to the tissue site by processor connector 141 and/or processor connector 142. Processor 140 may be configured to perform one or more mathematical operations on the signals received. Processor 140 may further be  
5 configured to deliver to display 145 a signal corresponding to mathematical operation(s) performed, data used in performing mathematical operation(s), and/or results of the mathematical operation(s). Display 145 may also receive from any system component signals  
10 corresponding to the amount and/or wavelength of light (a) emitted by light source 125, (b) delivered to the tissue site by light emission optics 120, (c) received by light detection optics 130, and/or (d) detected by detector 135.

15 System 110 may also include water probe location sensor 155. Sensor 155 may be configured to detect and/or receive location information. Location information may include the location and/or orientation of at least a portion of system 110, the location and/or  
20 orientation of the site of assessment, and/or the location and/or orientation of a reference point. Sensor 155 also may be configured to deliver a signal corresponding to location information to processor 140 via processor connector 143.

25 Disposable water probe 150 may include aperture 121, disposable fiber optic cable 122, fiber optic cable connector 123 (not expressly shown), aperture 131, disposable fiber optic cable 132, fiber optic cable connector 133 (not expressly shown), disposable water  
30 probe housing 151, spacer 152, and/or seal 153 as shown in FIGURE 5B. Spacer 152 may be a separate component of

probe 150. Alternatively, it may be formed simply by extending the walls of probe housing 151 a desirable distance beyond light emission aperture and/or light detection aperture. Water probe manipulator 160 may include water probe manipulator housing 161, at least a portion of fiber optic cable 124, and at least a portion of fiber optic cable 134. Water probe manipulator 160 may further include water probe location sensor 155 as shown in FIGURE 5B.

Power inlet or power source 117 may deliver power to controller 116 as shown in FIGURE 5B. In addition, power inlet or power source 117 may deliver power to keyboard 112, light source 125, light detector 135, processor 140, display 145, and/or location sensor 155. Power inlet or power source 117 may include a transformer and/or a battery (not expressly shown).

In some specific example embodiments, a probe or any portion thereof may be configured to be disposable, repairable, and/or replaceable. For example, an entire probe and/or a probe housing may be sanitized, sterilized, reconditioned, repaired, or replaced between (a) each assessment of a site, (b) each assessment of a subject, and/or (c) each subject (collectively, "each use"). A probe and/or a probe housing may be configured to have at least one sanitized or sterile surface to be placed at or near an assessment site. A sanitized or sterile surface may include a covering, e.g., a disposable disc and/or a disposable sleeve, that may be replaced between each use.

Artisans of ordinary skill will recognize that the exact configuration of systems and devices of the

invention may be varied without making them unsuitable for body fluid metric assessment. For example, although the non-limiting specific example embodiments shown in FIGURES 4A-5C shown depict a fiber optic cable between a light detection aperture and a light detector, this fiber optic cable is not essential in all specific example embodiments. In some specific example embodiments, for example, a light detector may be near or in contact with a light detection aperture. Similarly, light emission optics may be configured to deliver up to the entire amount of radiation emitted by a light source to a tissue site without fiber optic cables, e.g., by using direct illumination or one or more mirrors. In addition, while the specific example embodiments shown in FIGURES 4A-5C have only one each of a light emission fiber optic cable, a light emission fiber optic cable connector, a light emission disposable fiber optic cable, a light emission aperture, a light detection aperture, a disposable light detection fiber optic cable, a light detection fiber optic cable connector, and a light detection fiber optic cable, according to other specific example embodiments, a plurality of each may be used. For example, two or more light detection fiber optic cables may be used to enhance the sensitivity of light detection.

According to some specific example embodiments, light emission optics may be tuned to emit radiation at a plurality of narrow spectral wavelengths. For example, a plurality of narrow spectral wavelengths may be chosen so that a biological compound of interest will absorb. A plurality of narrow spectral wavelengths may also be chosen so that the light absorbed by species other than

the biological compound of interest is minimized.

Reduced absorption by interfering species may be anywhere within a range from just detectably less absorption than the biological compound of interest to zero absorption.

5 For example, the light absorbed by the interfering species may absorb 10% or less than that absorbed by the biological compound of interest.

In other examples, a plurality of narrow spectral wavelengths may be chosen to be preferentially absorbed  
10 by tissue water, non-heme proteins, and lipids, where preferentially absorbed wavelengths may be wavelengths whose absorption is substantially independent of the individual concentrations of non-heme proteins and lipids, and is substantially dependent on the sum of the  
15 individual concentrations of non-heme proteins and lipids. In further specific example embodiments, a plurality of narrow spectral wavelengths may be chosen to ensure that measured received radiation is substantially insensitive to scattering variations and such that the  
20 optical path lengths through the tissue, e.g., dermis, at said wavelengths are substantially equal. In still other specific example embodiments, a plurality of narrow spectral wavelengths may be chosen to ensure that measured received radiation from a tissue location is  
25 insensitive to temperature variations, where said wavelengths are temperature isosbestic in the water absorption spectrum or the received radiation is combined in a way that substantially cancels temperature dependencies of the individual wavelengths of received  
30 radiation when computing tissue water fractions.

Light emission optics and/or light detection optics may be mounted within the probe housing and positioned with appropriate alignment to enable detection in a transmissive mode and/or a reflective mode. Light emission optics and/or light detection optics may be placed in a remote unit operably connected to a probe housing through optical fibers. Light emission optics may include any electromagnetic radiation emitter. An electromagnetic radiation emitter may include an incandescent light source, a white light source, a light emitting diode ("LED"), and/or a laser (e.g., a Vertical Cavity Surface Emitting Laser). In some specific example embodiments, a laser may be selected for use with a fiber optic sensor according to the high efficiency with which lasers may be coupled into fiber optics.

In some specific example embodiments, a processing device may receive and compare at least two sets of optical measurements, where the at least first set of optical measurements corresponds to the detection of light whose absorption is primarily due to water, lipids and non-heme proteins, and where the at least second set of optical measurements corresponds to the detection of light whose absorption is primary due to water, and where a comparison of said at least two optical measurements provides a measure of the absolute water fraction within said tissue location. In other specific example embodiments, a processing device may receive and compare at least two sets of optical measurements, where said at least two sets of optical measurements are based on received radiation from at least two wavelengths and which are combined to form either a single ratio of said

received radiation, a sum of ratios of said received radiation or ratio of ratios of said received radiation. In additional specific example embodiments, a processing device may receive and compare at least two sets of  
5 optical measurements from at least two different wavelengths, where absorption of light at said at least two different wavelengths is primarily due to water which is in the vascular blood and in the extravascular tissue, and where a ratio of said at least two measurements  
10 provides a measure of a difference between the fractions of water in the blood and surrounding tissue location.

A systems and/or device according to the disclosure may be calibrated with every use, periodically, occasionally, as needed, or as otherwise desired. In  
15 some embodiments, a water fluid metric assessment of the disclosure may be effected very little, if at all, by wavelength independent changes in overall light intensity. In some embodiments, however, wavelength dependent changes in light intensity (e.g., "color  
20 shifts") may have the potential to effect measurement accuracy. The intensity of a source may be calibrated using, in some embodiments, a Teflon block due to its stable diffuse reflectance. The frequency of  
calibrations may depend, in part, on the stability of the  
25 source.

**Table 2**

<b>Figure</b>	<b>4A, 4B</b>	<b>5A, 5B, 5C</b>
<b>system</b>	<b>10</b>	<b>110</b>
base unit		111
keyboard		112
<b>housing</b>	<b>15</b>	<b>115</b>
trigger	16	
controller		116
battery	17	
power inlet or source		117
optical fiber bundle		118
optical fiber bundle housing		119
<b>light emission optics</b>	<b>20</b>	<b>120</b>
light emission aperture	21	121
disposable fiber optic cable	22	122
fiber optic cable connector	23	123
fiber optic cable	24	124
light source	25	125
<b>light detection optics</b>	<b>30</b>	<b>130</b>
light detection aperture	31	131
disposable fiber optic cable	32	132
fiber optic cable connector	33	133
fiber optic cable	34	134
<b>light detector</b>	<b>35</b>	<b>135</b>
<b>processor</b>	<b>40</b>	<b>140</b>
processor connector		141
processor connector		142
processor connector		143
<b>display</b>	<b>45</b>	<b>145</b>
<b>water probe</b>	<b>50</b>	<b>150</b>
water probe housing	51	151
spacer	52	152
seal	53	153
water probe connector	54	154
connector tab		154a
connector groove		154b
<b>water probe location sensor</b>	<b>55</b>	<b>155</b>
location sensor connector		156
<b>probe manipulator</b>		<b>160</b>
probe manipulator housing		161

As will be understood by those skilled in the art, other equivalent or alternative methods for the measurement of the water fraction within tissue ( $f_w$ ), as well as shifts in fluid between the intravascular and extravascular compartments, IVF-EVF or Q, according to 5 embodiments of the present disclosure can be envisioned without departing from the essential characteristics thereof. For example, devices of the disclosure may be manufactured in either a handheld or a tabletop 10 configuration, and may be operated sporadically, intermittently, and/or continuously. Moreover, individuals skilled in the art of near-infrared spectroscopy would recognize that additional terms can be added to the algorithms used herein to incorporate 15 reflectance measurements made at additional wavelengths and thus improve accuracy further. Also, light sources or light emission optics other than LED's including and not limited to incandescent light and narrowband light sources appropriately tuned to the desired wavelengths 20 and associated light detection optics may be placed within the probe housing which may be placed near the tissue location or may be positioned within a remote unit; and which deliver light to and receive light from the probe location via optical fibers. Additionally, 25 optical detectors may function in a forward-scattering mode, a back-scattering mode, a reflection mode, and/or a transmission mode. While the description provides a number of formulas and mathematical operations for calculating body-fluid metrics, it will be appreciated by 30 those of ordinary skill in the art that the same figures may be obtained using comparable alternative formulas and

operations. These equivalents and alternatives along with obvious changes and modifications are intended to be included within the scope of the present disclosure. Accordingly, the foregoing disclosure is intended to be illustrative, but not limiting, of the scope of the disclosure as illustrated by the following claims.

### EXAMPLES

#### Example 1

10 A porcine animal model of over-hydration was used to evaluate the correlation of local and whole-body fat-free percent water. Animals each received one liter of Ringer's lactate solution over 20 minutes of each hour for five hours.

15 Local hydration of animal tissue was assessed in hundreds of torso skin biopsies. Animals were positioned on their sides and three biopsies were taken from each animal, one each from at, above, and below the midline of the torso. The results of this study are shown in FIGURE 20 6. For each animal,  $f_w^l$  was significantly higher at low elevation than at high elevation. In addition,  $f_w^l$  of the mid-line biopsies strongly correlated with whole-body  $f_w^l$ .

Without being limited to any particular mechanism of action, these elevation-dependent results may be attributable to movement of extracellular water due to differences in hydrostatic pressure of perhaps 10 cm H<sub>2</sub>O (7.5 mm Hg). A very large number of tissue biopsy analyses had to be averaged to demonstrate this relationship, due to the errors inherent in excising bleeding pieces of tissue, followed by the errors inherent in desiccating, defatting, and repeatedly

weighing these tiny samples. Similar increases in local tissue hydration have also been observed in human volunteers with sensors on their foreheads when the head was placed below the heart.

5 Example 2

At the same time the tissue biopsies of Example 1 were taken, fat-free percent water was assessed optically. Each sensor was affixed to a single tissue site. Results obtained from consecutive optical  $f_w'$  assessments had a standard deviation of only 0.17%. These results are graphically depicted for a single, typical subject in FIGURE 7.

Based on analysis of run-to-run changes in optical  $f_w'$  estimates, a set of two probes affixed to two similar tissue sites having different hydrostatic pressures should be able to resolve differences in local  $f_w'$  with a standard deviation of about 0.25%, and with relatively short measurements, enabling FwEC to be detected with very high precision.

20

CLAIMSWHAT IS CLAIMED IS:

1. A method for assessing a whole-body water metric in a subject, said method comprising:

5 assessing a localized water metric at a tissue site in the subject using a probe;  
acquiring tissue site location information; and  
processing the localized water metric and the tissue site location information to produce a whole-body water  
10 metric of the subject.

2. A method according to claim 1, wherein the whole-body water metric is selected from the group of whole-body water metrics consisting of total tissue water  
15 fraction,  $f_w^T$ , fat-free water fraction,  $f_w^f$ , intravascular water fraction,  $f_w^{IV}$ , extravascular water fraction,  $f_w^{EV}$ , interstitial water fraction  $f_w^{IS}$ , extracellular water fraction,  $f_w^{EC}$ , water balance index,  $Q$ , and combinations thereof.

20

3. A method according to claim 1, wherein the whole-body water metric is selected from the group of whole-body water metrics consisting of changes in the total tissue water fraction,  $\Delta f_w^T$ , changes in the fat-free  
5 water fraction,  $\Delta f_w^1$ , changes in the intravascular water fraction,  $\Delta f_w^{IV}$ , changes in the extravascular water fraction,  $\Delta f_w^{EV}$ , changes in the interstitial water fraction,  $\Delta f_w^{IS}$ , changes in the extracellular water fraction,  $\Delta f_w^{EC}$ , changes in the water balance index,  $\Delta Q$ ,  
10 and combinations thereof.

4. A method according to claim 1, wherein the tissue site comprises skin.

15 5. A method according to claim 1, wherein assessing the localized water metric comprises measuring bioimpedance, transepidermal water loss, viscoelasticity, infrared light, magnetic resonance, ultrasound, or combinations thereof.

20 6. A method according to claim 1, further comprising exhibiting the localized water metric, the tissue site location information, or the localized water metric and the tissue site location information on a  
25 display.

7. A method according to claim 1, wherein acquiring tissue site location information comprises assessing the location of the probe.

8. A method according to claim 7, wherein assessing the location of the probe comprises detecting probe location information with a probe location information sensor.

5

9. A method according to claim 8, wherein the probe and the probe location information sensor are contained within a single unit.

10

10. A method according to claim 8, wherein the probe and the probe location information sensor are physically connected by a linker.

15

11. A method according to claim 8, wherein the probe location information sensor comprises a camera, an optical emitter, an optical detector, an ultrasound emitter, an ultrasound detector, a piezoelectric vibratory gyroscope, or combinations thereof.

20

12. A method according to claim 1, wherein the subject is a mammal.

25

13. A method according to claim 12, wherein the mammal is a human.

14. A method according to claim 1, wherein processing the localized water metric and the tissue site location to produce a whole-body water metric in the subject comprises comparing the localized water metric and the tissue site location information with corresponding values in a database of body water metric data.

15. A method according to claim 14, wherein the database of body water metric data comprises data for one subject.

16. A method according to claim 14, wherein the database of body water metric data comprises data for two or more subjects.

17. A method for assessing a whole-body water metric in a subject, said method comprising:

- emitting light of at least one wavelength from a light source toward a tissue site, wherein a portion of the emitted light is reflected by the tissue site;
- detecting at least one wavelength of the light reflected by the tissue site with a detector positioned from about one millimeter to about five millimeters from the tissue site;
- assessing the tissue site location;
- processing the detected reflected light from the tissue site to determine a tissue site water metric; and
- processing the tissue site water metric and the tissue site location to produce the whole-body water metric.

18. A method according to claim 17, wherein the whole-body water metric is selected from the group of whole-body water metrics consisting of total tissue water fraction,  $f_w^T$ , fat-free water fraction,  $f_w^L$ , intravascular water fraction,  $f_w^{IV}$ , extravascular water fraction,  $f_w^{EV}$ , interstitial water fraction  $f_w^{IS}$ , extracellular water fraction,  $f_w^{EC}$ , water balance index,  $Q$ , and combinations thereof.

10

19. A method according to claim 17, wherein the whole-body water metric is selected from the group of whole-body water metrics consisting of changes in the total tissue water fraction,  $\Delta f_w^T$ , changes in the fat-free water fraction,  $\Delta f_w^L$ , changes in the intravascular water fraction,  $\Delta f_w^{IV}$ , changes in the extravascular water fraction,  $\Delta f_w^{EV}$ , changes in the interstitial water fraction,  $\Delta f_w^{IS}$ , changes in the extracellular water fraction,  $\Delta f_w^{EC}$ , changes in the water balance index,  $\Delta Q$ , and combinations thereof.

15  
20

20. A method according to claim 17, further comprising comparing the whole-body water metric with a control and determining from that comparison whether the subject's tissue, organ, or body is dehydrated or over-hydrated.

25

21. A method according to claim 20, further comprising administering a hydration therapy to a dehydrated subject.

30

22. A method according to claim 20, further comprising administering a dehydration therapy to an over-hydrated subject.

5

23. A method according to claim 17, further comprising exhibiting the tissue site water metric, the whole-body water metric, or the tissue site water metric and the whole-body water metric on a display.

10

24. A method according to claim 17, wherein the light detected by the detector comprises a wavelength selected from the group of wavelength bands consisting of 950-1400 nm, 1500-1800 nm, and 2000-2300 nm.

15

25. A method according to claim 24, wherein the wavelength of light detected by the detector comprises a wavelength selected from the group of wavelengths consisting of 1180 nm, 1125 nm, 1168 nm, 1170 nm, 1185 nm, 1190 nm, 1230 nm, 1245 nm, 1250 nm, 1274 nm, 1275 nm, 1300 nm, 1330 nm, 1710 nm, 1730 nm, 1740 nm, and combinations thereof.

20

26. A method according to claim 24, wherein at least two wavelengths of light are detected by the first detector.

25

27. A method according to claim 26, wherein the wavelengths differ by at least 10 nm.

30

28. A method according to claim 17, wherein determining the tissue site water metric is substantially independent of light scattering variations and temperature variations.

5

29. A method according to claim 17, wherein the light source is from about one millimeter to about five millimeters from the tissue site.

10

30. A method according to claim 17, wherein the tissue site comprises skin.

15

31. A method according to claim 17, wherein acquiring tissue site location information comprises assessing the location of the probe.

20

32. A method according to claim 31, wherein assessing the location of the probe comprises detecting probe location information with a probe location information sensor.

25

33. A method according to claim 32, wherein the probe and the probe location information sensor are contained within a single unit.

34. A method according to claim 32, wherein the probe and the probe location information sensor are physically connected by a linker.

35. A method according to claim 32, wherein the probe location information sensor comprises a camera, an optical emitter, an optical detector, an ultrasound emitter, an ultrasound detector, a piezoelectric vibratory gyroscope, or combinations thereof.

36. A method according to claim 17, wherein the subject is a mammal.

37. A method according to claim 36, wherein the mammal is a human.

38. A method according to claim 17, wherein processing the localized water metric and the tissue site location to produce a whole-body water metric in the subject comprises comparing the localized water metric and the tissue site location information with corresponding values in a database of body water metric data.

39. A method according to claim 38, wherein the database of body water metric data comprises data for one subject.

40. A method according to claim 38, wherein the database of body water metric data comprises data for two or more subjects.

41. A method for diagnosing a water imbalance in a subject, said method comprising:

assessing a localized water metric at a tissue site in the subject using a probe;

5 acquiring tissue site location information;

processing the localized water metric and the tissue site location information to produce a whole-body water metric of the subject; and

10 comparing the whole-body water metric with a control and determining from that comparison whether the subject is appropriately hydrated, dehydrated or over-hydrated.

42. A method according to claim 41, wherein the whole-body water metric is selected from the group of  
15 whole-body water metrics consisting of total tissue water fraction,  $f_w^T$ , fat-free water fraction,  $f_w^f$ , intravascular water fraction,  $f_w^{IV}$ , extravascular water fraction,  $f_w^{EV}$ , interstitial water fraction  $f_w^{IS}$ , extracellular water fraction,  $f_w^{EC}$ , water balance index,  $Q$ , and combinations  
20 thereof.

43. A method according to claim 41, wherein the whole-body water metric is selected from the group of whole-body water metrics consisting of changes in the total tissue water fraction,  $\Delta f_w^T$ , changes in the fat-free  
5 water fraction,  $\Delta f_w^1$ , changes in the intravascular water fraction,  $\Delta f_w^{IV}$ , changes in the extravascular water fraction,  $\Delta f_w^{EV}$ , changes in the interstitial water fraction,  $\Delta f_w^{IS}$ , changes in the extracellular water fraction,  $\Delta f_w^{EC}$ , changes in the water balance index,  $\Delta Q$ ,  
10 and combinations thereof.

44. A method according to claim 41, wherein the tissue site comprises skin.

15 45. A method according to claim 41, further comprising administering a hydration therapy to the subject if determined to be dehydrated.

20 46. A method according to claim 41, further comprising administering a dehydration therapy to the subject if determined to be over-hydrated.

47. A system for assessing a whole body fluid metric in a subject, said system comprising:

a local fluid content probe configured to assess a local fluid metric at a tissue site;

5 a location information sensor configured to assess location information of the probe, the tissue site, or the probe and the tissue site; and

a processor, wherein the processor is operably coupled to the local fluid content probe, operably  
10 coupled to the location information sensor, and configured to process the local fluid content metric at the tissue site and location information to produce a whole-body fluid content metric.

15 48. A system according to claim 47, wherein the local fluid content probe comprises a bioimpedance probe.

49. A system according to claim 47, wherein the local fluid content probe comprises an optical  
20 spectrophotometry probe.

50. A system according to claim 47, wherein at least a portion of the system is configured to be sterile, sanitizable, disposable, replaceable, or  
25 repairable.

51. A system according to claim 47, wherein the whole body fluid metric comprises extracellular water content.

52. A system according to claim 47, wherein the local fluid metric comprises extracellular water content.

53. A system for assessing a body fluid metric,  
5 said system comprising:

a probe housing configured to be placed proximal to a tissue site;

a probe manipulator detachably connected to the probe housing and configured to place the probe housing  
10 proximal to the tissue site;

light emission optics connected to the probe housing and configured to deliver radiation of at least one wavelength to the tissue site;

light detection optics connected to the probe  
15 housing and configured to receive at least one wavelength of radiation from the tissue site;

a location information sensor configured to detect location information for the probe housing, location information for the tissue site, or combinations thereof;  
20 and

a processing device configured to process radiation from the light emission optics, radiation from the light detection optics, and location information from the location information sensor to produce a whole-body fluid  
25 metric.

54. A system according to claim 53, wherein the probe housing has at least one sterile or sanitized surface.

55. A system according to claim 53, wherein the probe housing is configured to be disposable.

56. A system according to claim 53, wherein the  
5 probe housing is configured to be replaceable.

57. A system according to claim 53 further comprising a replacement probe housing.

10 58. A system according to claim 53, wherein the location information sensor is connected to the probe housing.

59. A probe for assessing a body fluid metric, said  
15 probe comprising:

a probe housing configured to be placed proximal to a tissue site;

a near infrared light emission fiber optic cable connected to the probe housing and configured to conduct  
20 radiation of at least one wavelength to the tissue site;

a near infrared light detection fiber optic cable connected to the probe housing and configured to receive at least one wavelength of radiation from the tissue  
site;

25 a location information sensor connected to the probe housing and configured to detect location information for at least a portion of the probe housing, location information for at least a portion of the tissue site, or combinations thereof; and

30 at least one sterile surface.

60. A probe according to claim 59, wherein the probe is configured to be disposable.

61. A probe according to claim 59 further  
5 comprising a processing device configured to process radiation from the light emission fiber optic cable, radiation from the light detection fiber optic cable, and location information from the location information sensor to produce a body fluid-related metric.

10

62. A system for assessing a whole body fluid metric, said system comprising:

a means for assessing a local fluid content metric at a tissue site of interest;

15

a means for assessing a local fluid content metric at a tissue reference site; and

a means for processing a local fluid content at a tissue site of interest and a local fluid content at a tissue reference site to produce a whole-body fluid  
20 content metric.

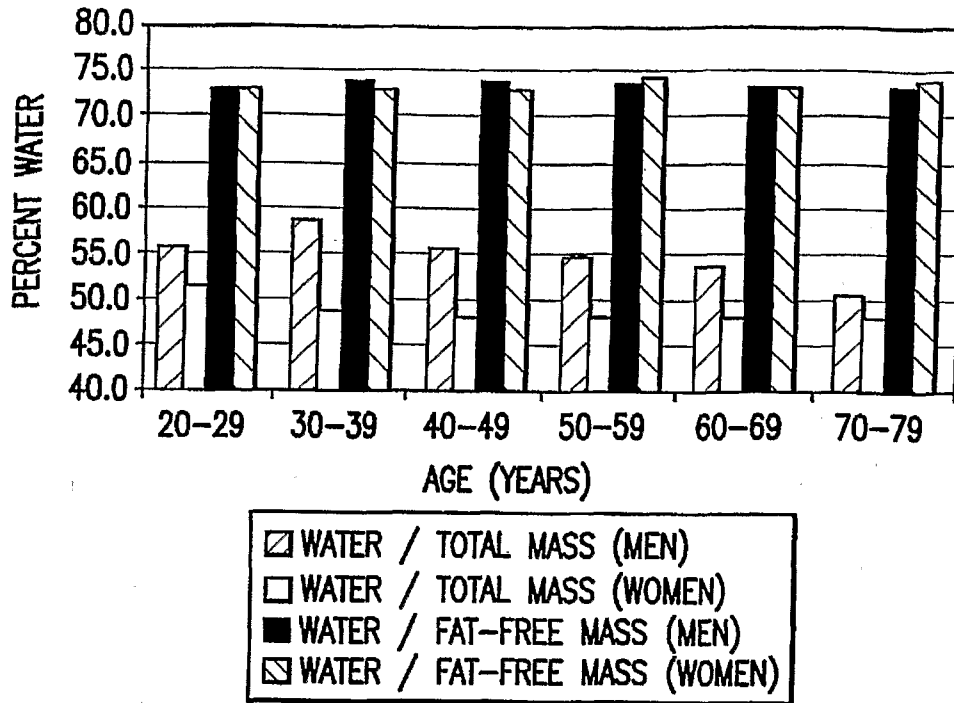

FIG. 1

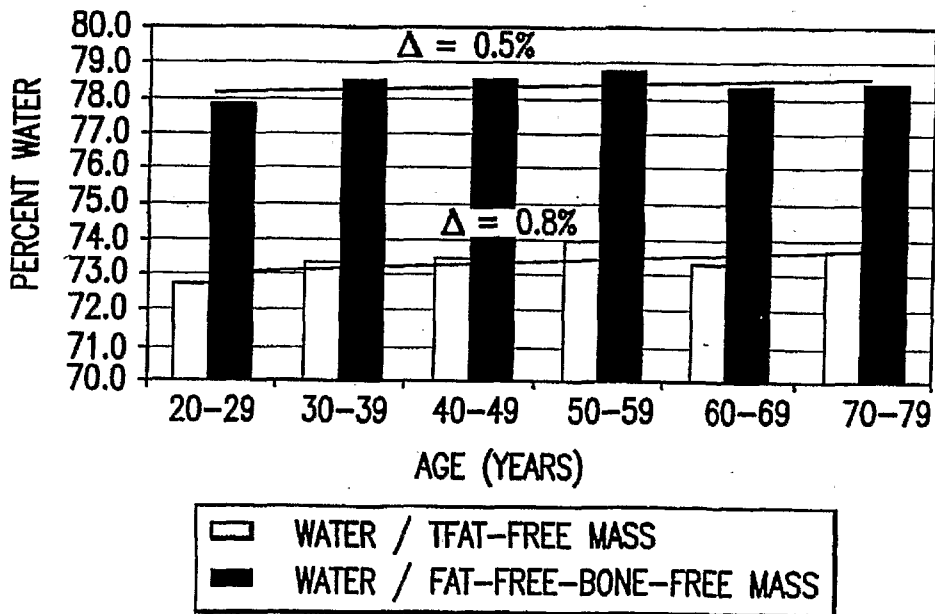

FIG. 2

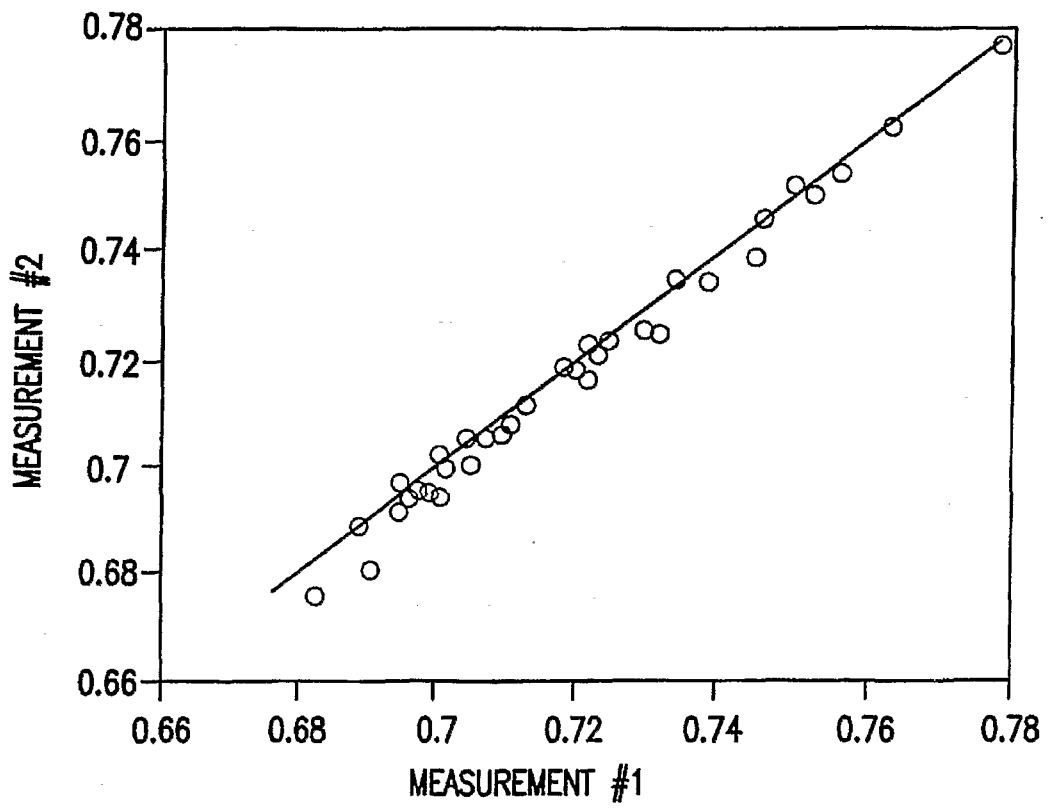
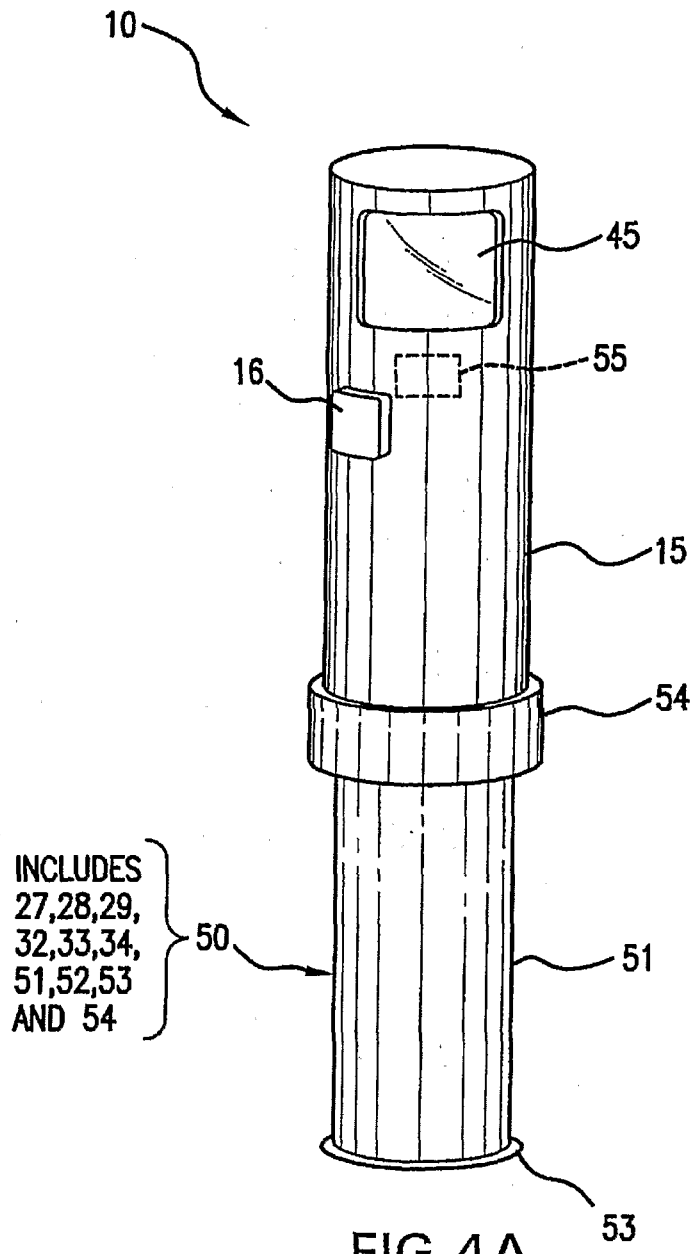

FIG.3



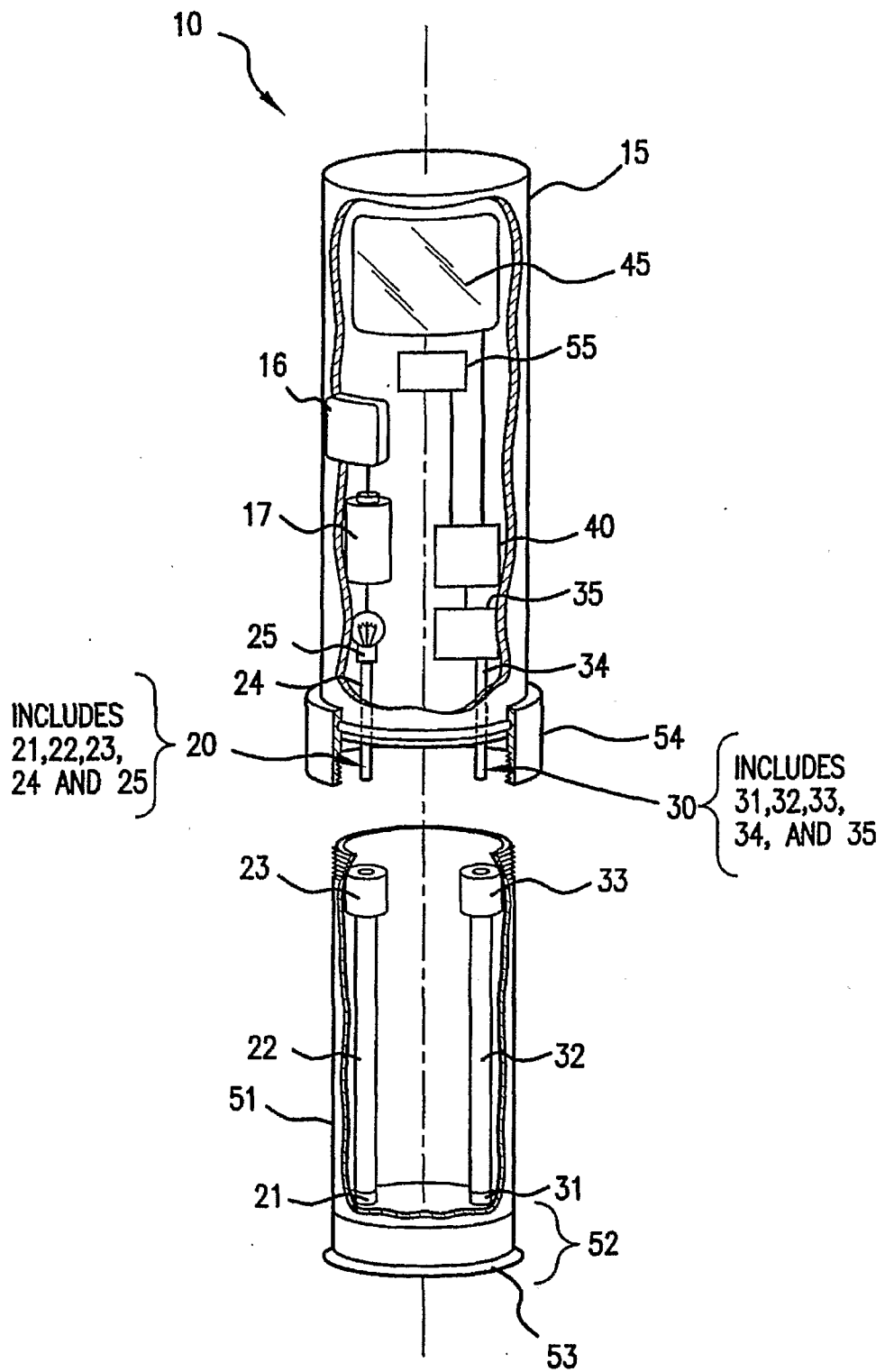

FIG. 4B

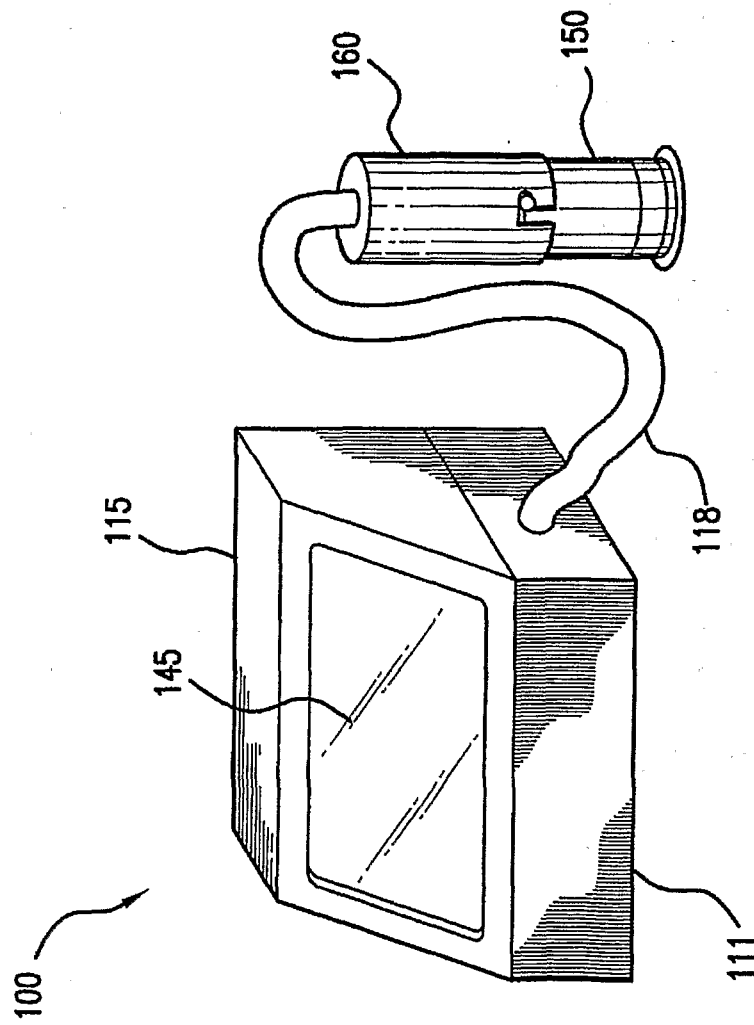

FIG. 5A

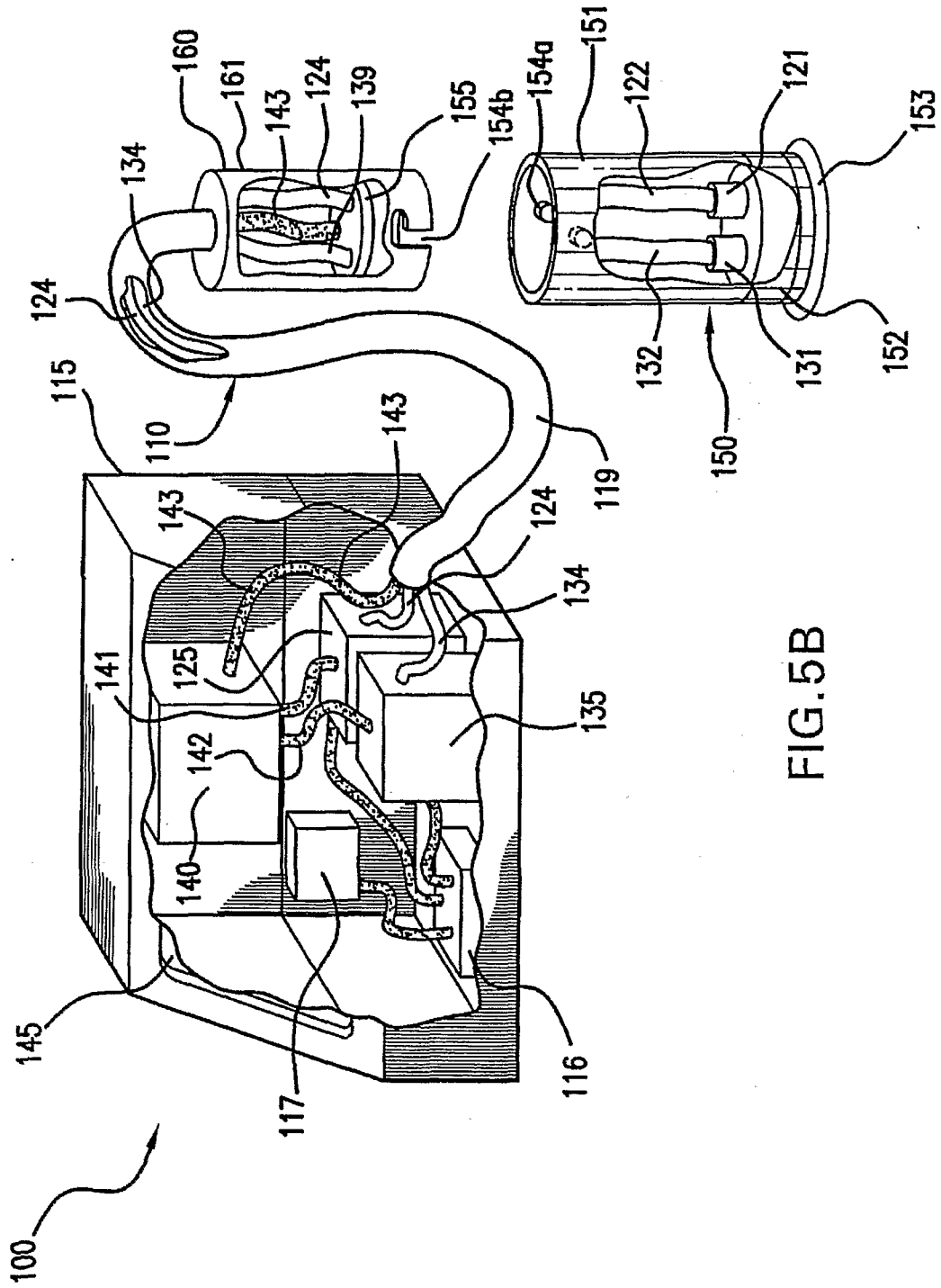

FIG. 5B

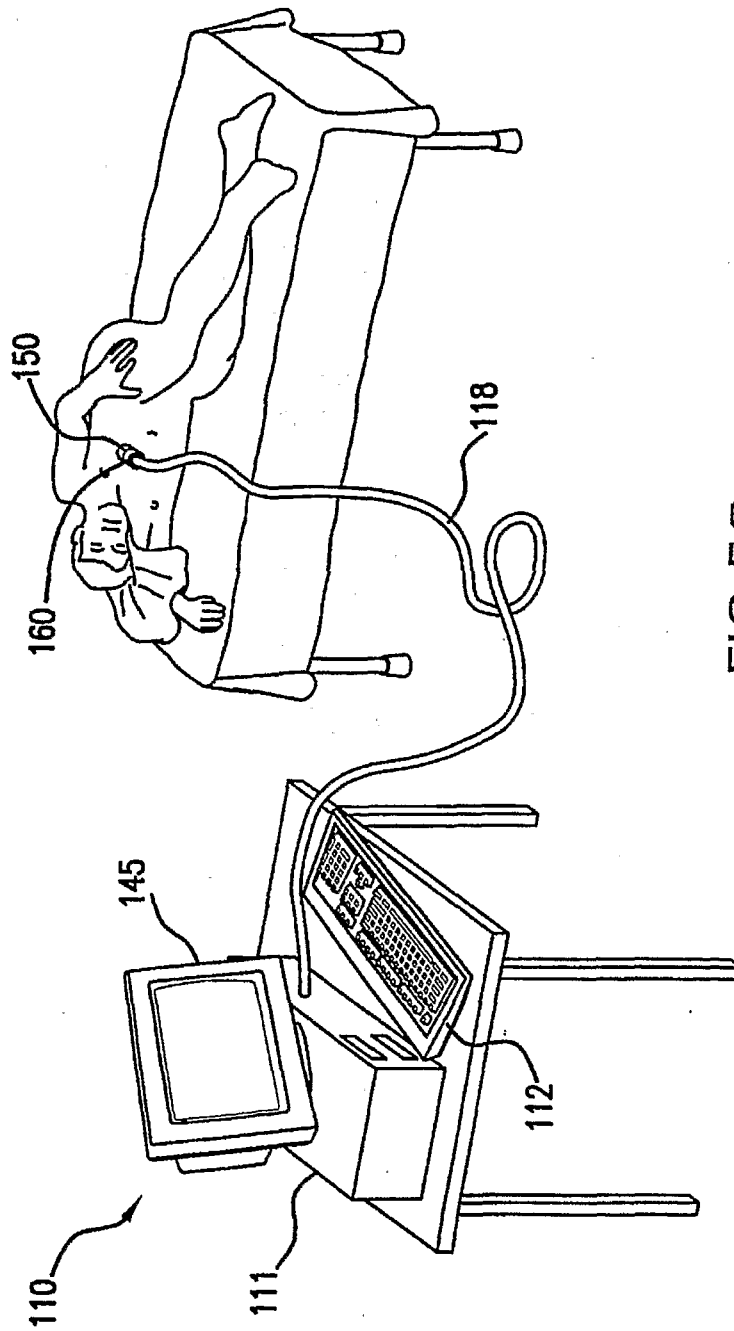

FIG. 5C

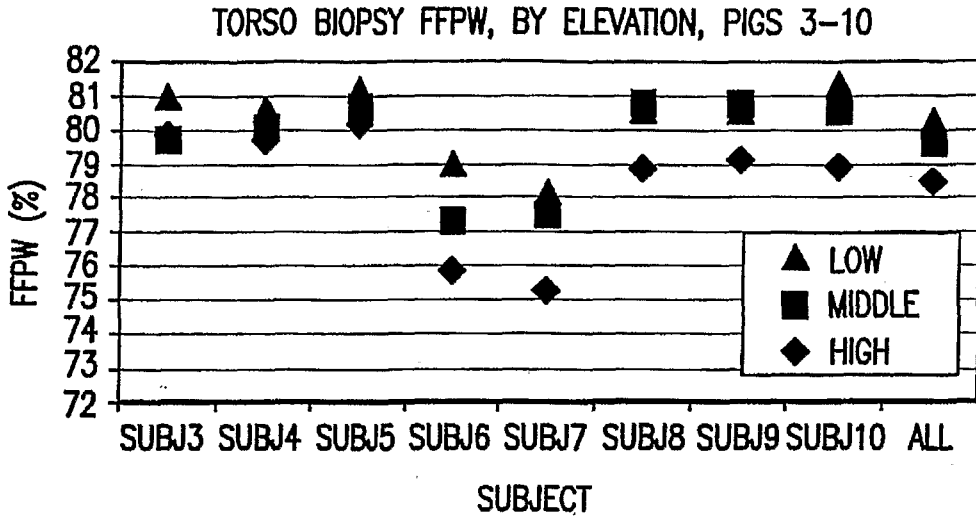
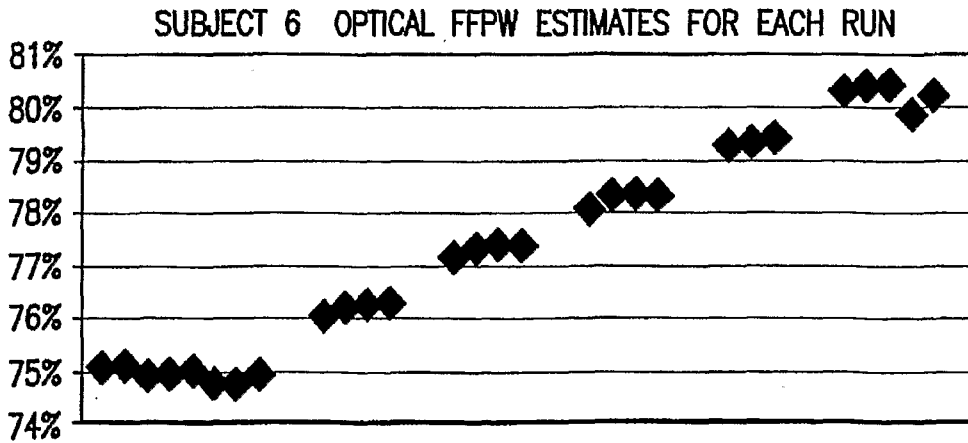

FIG. 6



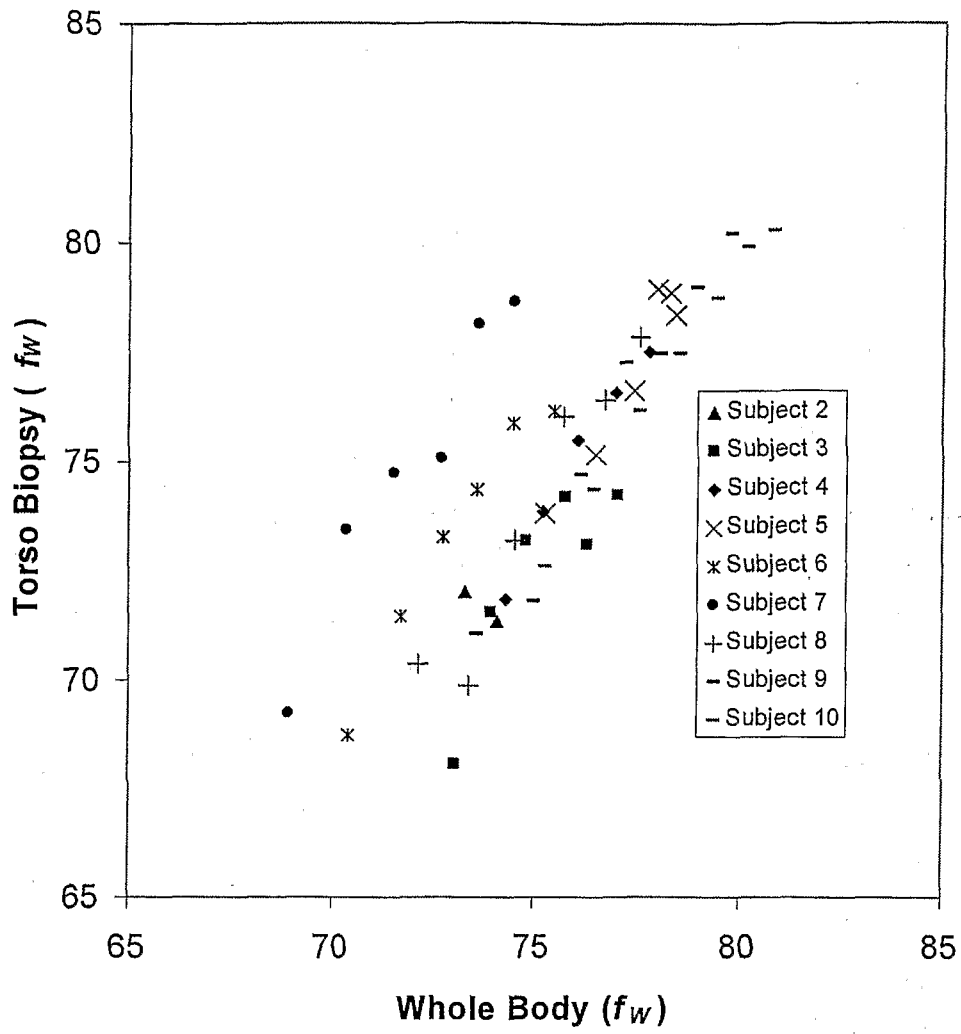

FIG. 8

10/10

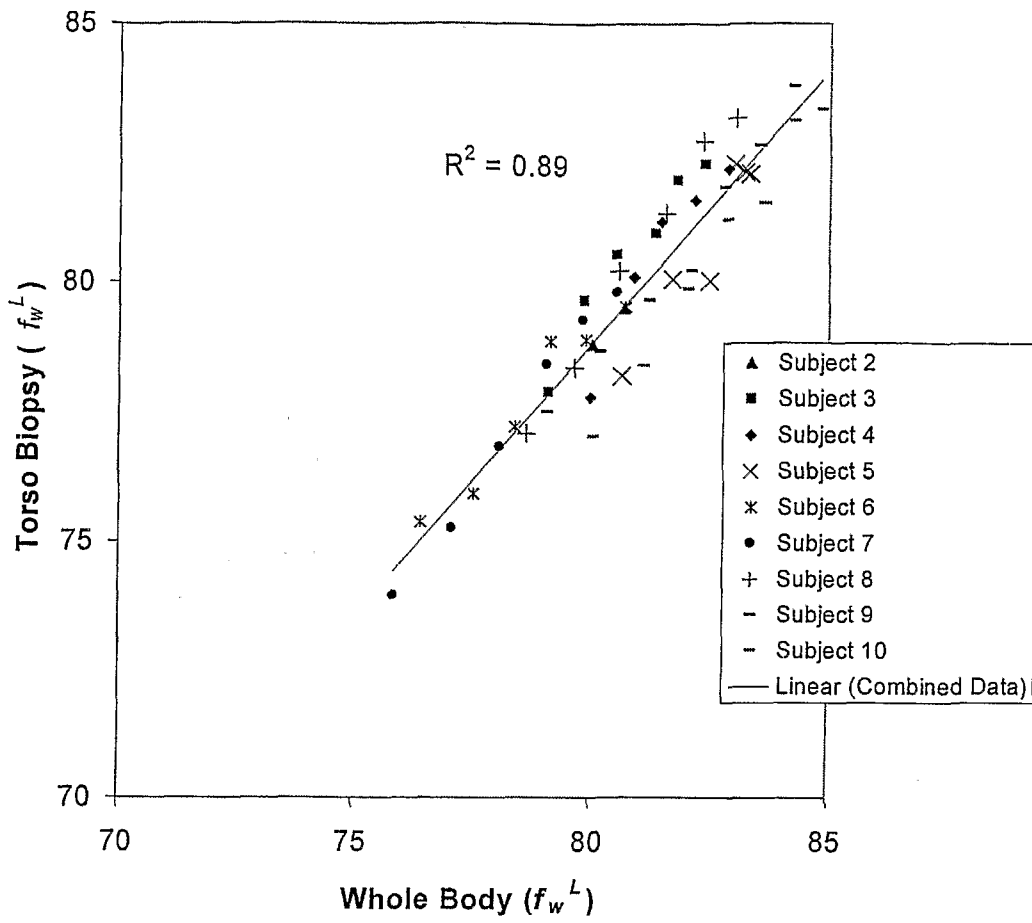

FIG. 9

专利名称(译)	评估一种或多种体液指标的系统和方法		
公开(公告)号	<a href="#">EP1948012A2</a>	公开(公告)日	2008-07-30
申请号	EP2006837790	申请日	2006-11-16
[标]申请(专利权)人(译)	内尔科尔普里坦贝内特公司		
申请(专利权)人(译)	NELLCOR PURITAN BENNETT LLC		
当前申请(专利权)人(译)	NELLCOR PURITAN BENNETT LLC		
[标]发明人	SCHMITT JOSEPH		
发明人	BAKER, CLARKE, R., JR. SCHMITT, JOSEPH		
IPC分类号	A61B5/00 G01N21/35		
CPC分类号	A61B5/0059 A61B5/02438 A61B5/14546 A61B5/4869 A61B5/4878 G01N21/3554 G01N21/359 G01N21/474 G01N2021/3181		
代理机构(译)	GRUBERT , ANDREAS		
优先权	11/282947 2005-11-18 US		
外部链接	<a href="#">Espacenet</a>		

#### 摘要(译)

本公开提供了用于评估体液相关度量和/或其中的变化的系统，设备和/或方法。本公开还提供用于将特定组织中的体液相关度量与相应的全身度量相关联的系统，设备和/或方法。本公开还提供了用于评估这些度量以促进与维持和/或恢复体液平衡相关的诊断和/或治疗干预的系统，装置和/或方法。