

(19) World Intellectual Property Organization
International Bureau



(43) International Publication Date
6 May 2004 (06.05.2004)

PCT

(10) International Publication Number
WO 2004/037083 A1

(51) International Patent Classification⁷: A61B 5/103

(21) International Application Number:
PCT/US2002/034245

(22) International Filing Date: 24 October 2002 (24.10.2002)

(25) Filing Language: English

(26) Publication Language: English

(71) Applicant: ATHENA FEMININE TECHNOLOGIES, INC. [US/US]; 179 Moraga Way, Orinda, CA 94563 (US).

(72) Inventors: HOCHMAN, Joel, S.; 510 West 9 th St., Houston, TX 77007 (US). SARKIS, George; 179 Moraga Way, Orinda, CA 94563 (US).

(74) Agent: BECKER, Robert, W.; Robert W. Becker & Associates, Suite B, 707 Highway 66 East, Tijeras, NM 87059 (US).

(81) Designated States (*national*): AE, AG, AL, AM, AT, AU, AZ, BA, BB, BG, BR, BY, BZ, CA, CH, CN, CO, CR, CU, CZ, DE, DK, DM, DZ, EC, EE, ES, FI, GB, GD, GE, GH, GM, HR, HU, ID, IL, IN, IS, JP, KE, KG, KP, KR, KZ, LC, LK, LR, LS, LT, LU, LV, MA, MD, MG, MK, MN, MW, MX, MZ, NO, NZ, OM, PH, PL, PT, RO, RU, SD, SE, SG, SI, SK, SL, TJ, TM, TN, TR, TT, TZ, UA, UG, UZ, VC, VN, YU, ZA, ZM, ZW.

(84) Designated States (*regional*): ARIPO patent (GH, GM, KE, LS, MW, MZ, SD, SL, SZ, TZ, UG, ZM, ZW), Eurasian patent (AM, AZ, BY, KG, KZ, MD, RU, TJ, TM), European patent (AT, BE, BG, CH, CY, CZ, DE, DK, EE, ES, FI, FR, GB, GR, IE, IT, LU, MC, NL, PT, SE, SK, TR), OAPI patent (BF, BJ, CF, CG, CI, CM, GA, GN, GQ, GW, ML, MR, NE, SN, TD, TG).

Published:
— with international search report

For two-letter codes and other abbreviations, refer to the "Guidance Notes on Codes and Abbreviations" appearing at the beginning of each regular issue of the PCT Gazette.

(54) Title: VAGINAL SENSING AND STIMULATING USING 2-WAY WIRELESS COMMUNICATIONS

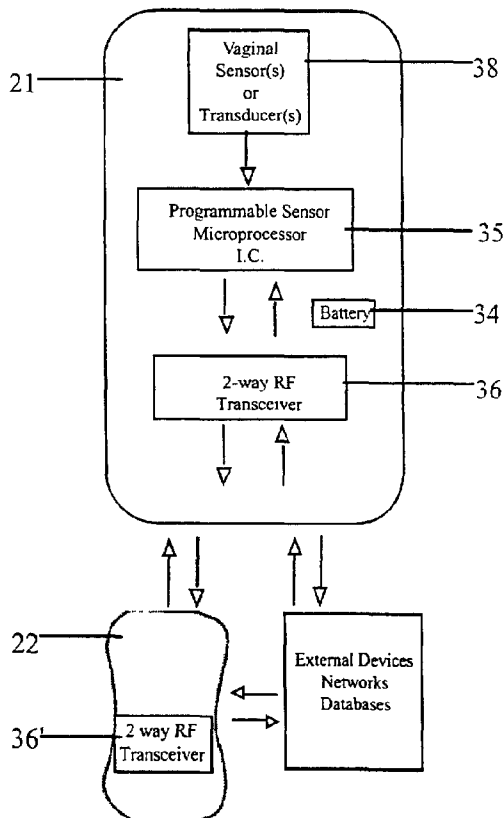

(57) Abstract: A system and method are provided for transducing vaginal conditions, affecting vaginal or body conditions, and/or stimulating perineal musculature and nerves. A separate, portable, non-implanted intravaginally containable combination probe and transceiver (21) is provided that can sense vaginal conditions, can deliver signals or medication, and/or can stimulate perineal musculature and nerves. This probe unit is provided with 2-way wireless communication for transmitting information that is transduced and for receiving control and programming signals. In addition, a separate combination controller and transceiver (22) is provided for wirelessly sending signals to the probe unit and for receiving signals therefrom. A real time wireless signal feedback loop is thus provided between the controller and the probe and/or external devices, networks and databases.

WO 2004/037083 A1

- 1 -

SYSTEM AND METHOD FOR TRANSDUCING, SENSING, OR
AFFECTING VAGINAL OR BODY CONDITIONS, AND/OR
STIMULATING PERINEAL MUSCULATURE AND NERVES USING 2-
WAY WIRELESS COMMUNICATIONS

5

Technical Field

The present invention relates to a system for transducing vaginal conditions, affecting vaginal or body conditions and/or stimulating perineal musculature and nerves. The present invention also relates to a method for accomplishing these functions.

10

Background Art

US Patent 4,515,167, Hochman, discloses a self-contained stimulation device that was programmable, prior to use, using control buttons on the surface of the device itself. Signals could also be emitted from the device to an external unit for processing. The drawbacks of this known device include the inability to alter its operation during use. In addition, this known device is not very ergonomic due in particular to the surface control buttons that are necessarily present on the device for its programming and operation.

15

Other vaginally insertable probes are also known, such as the fertility probes of US design patent 393,311 and US patent 5,916,173, both to Kirsner. US patent 4,753,247, Kirsner, discloses a probe that is connected by wires to an external housing containing batteries and electronic circuitry.

20

Prior known devices fail to provide a system that can provide stimulation, deliver medication, and/or obtain physiological data intravaginally, via a wireless 2-way communication and in real time.

25

Disclosure of the Invention

It is therefore an object of the present invention to provide an ergonomic system and method that will allow, in a wireless manner

30

- 2 -

and in real time, the transducing of vaginal conditions, the affecting of vaginal or body conditions, and the stimulation of perineal musculature and nerves in the human or other mammalian vagina, and in particular allows for real time remote control and/or programming of the intravaginally contained probe/transceiver unit.

5

The system of the present invention comprises: a separate, portable, non-implanted, intravaginally containable (i.e. in situ yet removable) combination probe and transceiver that is provided with means for sensing vaginal conditions, delivering signals or medication, and/or stimulating perineal musculature and nerves, wherein such probe unit is provided with 2-way wireless real time communication means for transmitting information that is transduced and for receiving control and programming signals; and a separate combination controller and transceiver that is provided with wireless means for sending signals to the probe unit and for receiving signals therefrom, wherein a wireless signal feedback loop is provided between the controller and probe units and external devices, networks and databases.

10

15

20

The combination probe and transceiver is, in particular, a pre-programmed unit. The programming of this unit can, however, be altered. As indicated, 2-way communication is provided between the probe unit and the controller unit, which can be a hand-held unit, but could alternatively or in addition be a PC or other similar computer unit.

25

The probe of the inventive system contains no wires or similar external means or surface controls, and is therefore comfortable to use.

When the probe unit of the inventive system is used as a stimulation unit, women are provided a safe, easy and convenient way

- 3 -

to strengthen and tone their pelvic muscles without professional intervention or special training.

5 In addition, or alternatively, the probe unit of the inventive system can be provided with solid state transducers or other sensor means that would be able to identify, for example, sexually transmitted pathogens, cancerous changes in the cervix and vaginal environment, metabolic abnormalities, physiological markers of the fertility cycle, and other physiological information. It may also be possible in this way to identify diseases by DNA sequences or by disease-specific molecular odors. The inventive system thus affords the ability of being able to provide the earliest possible diagnosis and treatment of pathological conditions, since it is now possible with the inventive system to obtain intracorporeal physiological information without the need for parenteral or invasive sampling. In other words, physiological information can be wirelessly tracked and monitored, allowing observation and supervision of metabolic and fertility activities, among others. This can even be done from a remote site, since the diagnostic data can be wirelessly transmitted to local hubs, local area networks, personal computers, and the internet. Thus, the inventive system can provide sophisticated diagnostic data to the user, to her physician, and to internet-hosted diagnostic services. Of particular significance is that this transfer of information is accomplished in real time.

10

15

20

Further specific features of the present invention will be explained in detail subsequently.

25 Brief Description of the Drawings

The features of the invention, and its technical advantages, can be seen from the following description of the preferred embodiments together with the claims and the accompanying drawings, in which:

- 4 -

Figs. 1 and 2 show the probe/transceiver and the controller/transceiver units respectively of the system of the present invention;

Fig. 3 shows the probe and controller units in a case; and

5 Figs. 4-6 diagrammatically show the micro circuitry for various exemplary embodiments of the inventive probe and controller units.

Detailed Description of Preferred Embodiments

10 Referring now to the drawings in detail, the inventive system, which is designated generally by the reference numeral 20 (Fig. 3), essentially comprises two separate straightforward, self-contained units, namely a combination probe and transceiver 21 and a combination controller and transceiver 22. The required components of these units are integrated and, where appropriate, sealed into these
15 two units. The bodies of the units 21,22 are made of a plastic, such as those approved for medical use by the Food and Drug Administration. An example of such a plastic is medical grade level polycarbonate.

Although, as indicated previously, the inventive system 20 has numerous applications, including sensing or transducing vaginal conditions, affecting vaginal or body conditions, and/or stimulating
20 perineal musculature and nerves, the system will now be explained in conjunction with use as a stimulation system.

When the system 20 is used as a stimulation system, the combination probe and transceiver unit is characterized as a stimulator
25 unit. In one specific embodiment of the present invention, such a stimulator unit is less than 1 inch in diameter and less than 4 inches in length. The end 24 of the unit 21 is rounded to facilitate vaginal insertion. The opposite end of the unit can be provided with, for example, an eyelet 25 to which a cord or similar device can be

- 5 -

attached to facilitate removal of the reusable unit. The body of the unit is provided with at least one electrode ring 26 (two such rings are shown in the embodiment illustrated in Fig. 1), with these electrode rings being flush with the outer surface of the unit. The electrode rings
5 26 are designed to deliver electrical pulses to the muscles and/or nerves of the pelvic floor, and are preferably metallic rings, although they could also be made of non-metallic conducting material such as doped silicon. The stimulator unit 21 is furthermore provided with a microprocessor, a radio transmitter and a receiver mounted on a circuit
10 board, an antenna and a sealed battery, as will be discussed in detail subsequently.

The operation of the combination probe and transceiver in its function as a stimulator unit will now be described by way of example. To begin a session, a woman would remove the hand-held
15 combination controller and transceiver (the control unit) 22 and the stimulator unit 21 from the holder or case 28 (see Fig. 3), which also includes a tester 27 for the probe or stimulator unit. The stimulator unit 21 is then inserted into the vagina. The stimulator unit 21 can be turned on automatically at a low level when it is removed from the case
20 28; this can be accomplished, for example, either by a signal from the control unit 22 or can be triggered by a non-illustrated magnet located in the case 28. Although automatic powering up is preferred, the stimulator unit 21 can also be turned on manually using the on/off button 30 of the control unit 22.

25 The stimulator unit 21 can operate entirely automatically by being preprogrammed. For example, the unit can start at a low level of about 2 volts, can hold this voltage for approximately 30 seconds or any other desired period of time, and can then automatically ramp up to, for example, 5 volts. The stimulator unit 21 could also be operated

- 6 -

manually by the control unit 22, or the control unit could be used to override the programmed stimulator unit 21. For example, the hand-held control unit 22 can be used to increase the stimulation strength in small steps until a user feels the muscles contract. This would be accomplished by using the Increase button 31. Should the woman feel any discomfort, she can decrease the strength of stimulation by pushing the Decrease button 32, or can turn the system off by pushing the OFF button 30. The system can be programmed to run for a specified period of time, for example in fifteen minute cycles, after which it will automatically shut off. The stimulator unit 21 can then be removed.

During a session, which, as indicated above, could run for approximately 15 minutes, the stimulator unit 21 is programmed to follow a pattern of several stimulation cycles, each of which is followed by a rest period with a repeat of the set of stimulation cycles and rest periods. The stimulation patterns are the well known Kegel patterns. The stimulator unit 21 can be programmed so that it will automatically ramp up to the setting of a previous use; in other words, the stimulator unit and/or the control unit 22 is provided with a memory.

To accomplish the various functions of the system 20, namely of the control unit 22 and the stimulator or combination probe and transceiver unit 21, these units are provided with a number of components (see Fig. 4). In particular, the stimulator unit 21 and control unit 22 respectively include a battery 34 (which could be a rechargeable battery), a microprocessor 35, and a radio transmitter and receiver, or preferably a transceiver 36, 36' which includes an antenna. The radio transmitters and receivers, or transceivers, of the control unit 22 and of the probe unit 21 are miniature radio transceivers of the same low power class as of the known remote keyless locking

- 7 -

5 devices used in automobiles. The programmable microprocessors of the units are designed to receive signals from the other unit and to deliver signals thereto, all in a wireless signal feedback loop, which may be closed or interactive. By way of example, electrical stimulation pulses can be delivered to the perineal musculature via the
aforementioned electrode rings 26.

10 The control unit 22 and the probe unit 21 can also be provided with wireless means to transmit signals to or receive signals from external devices, networks or databases, including a PC which may be located in a doctor's office, thereby facilitating data transmission and analysis.

It should also be noted that although the control unit 22 is preferably a hand-held unit, it could also be an appropriately programmed and equipped PC or the like.

15 As indicated above, the combination probe and transceiver unit 21 can be provided with means, such as one or more sensors with appropriate circuitry, for transducing vaginal conditions, delivering signals or medication, and/or stimulating perineal musculature and nerves. For this purpose, the combination probe and
20 transceiver 21 is provided with the 2-way wireless communication means 36 for transmitting transduced information to the control unit 22, external devices, networks or databases and for receiving control and programming signals therefrom. Similarly, the control unit or combination controller and transceiver 22 is provided with wireless
25 means, such as a transceiver 36', for sending wireless signals to the unit 21 and for receiving wireless signals therefrom. Thus, a wireless signal feedback loop is provided between the control unit 22 and the probe unit 21. Further inventive embodiments are illustrated in Figs. 5 and 6.

- 8 -

In particular, the combination controller and transceiver 22 can include means for altering the operational settings of the probe unit 21. The combination probe and transceiver 21 can be provided with sensing or transducing means in the form of a muscle contraction sensor, and the unit 21 can also be provided with medication delivery means. In addition, the control unit 22 can be provided with means for altering stimulation signal levels and/or medication delivery signals.

The combination probe and transceiver unit 21 can also be provided with stimulating means (as in the embodiment of Fig. 4), which can be programmed to provide increasing stimulation and/or medication over a given period of time. The stimulating means can include means for automatic adjustment of stimulation levels in response to sensed muscle contractions and/or changes in the vaginal environment. Such stimulating means can be remotely adjustable, for example from the control unit 22 or from another source.

The combination probe and transceiver unit 21 can also be provided with means for sampling cervical fluid, and/or with means for sensing temperature, pH, secretion viscosity, vaginal pathogens and atypical cervical cells. The various sensors and transducers can be provided at any suitable location on the probe as long as the ergonomic character of the probe is maintained. Where appropriate, the sensors/transducers could even be in the form of the electrode rings 26.

As indicated previously, the combination probe and transceiver unit 21 is a sealed unit.

The present invention is, of course, in no way restricted to the specific disclosure of the specification and drawings, but also encompasses any modifications within the scope of the appended claims.

- 9 -

CLAIMS:

1. A system for at least one of transducing vaginal conditions, affecting vaginal or body conditions, and stimulating perineal musculature and nerves, characterized by:

5 a separate, portable, non-implanted, intravaginally containable combination probe and transceiver (21) that is provided with means for at least one of sensing vaginal conditions, delivering signals or medication, and stimulating perineal musculature and nerves;

10 wherein said combination probe and transceiver (21) is provided with 2-way wireless communication means (36) for transmitting information that is transduced and for receiving control and programming signals; and

15 a separate combination controller and transceiver (22) that is provided with wireless means (36') for sending signals to said probe and for receiving signals therefrom;

wherein a wireless signal feedback loop is provided between said controller (22) and said probe (21) and which may be an interactive or closed signal feedback wireless loop.

20 2. A system according to claim 1, characterized in that said means of said combination wireless controller and transceiver (22) for sending signals includes means (36') for wirelessly altering operation settings of said probe.

25 3. A system according to claim 1 or 2, characterized in that said probe (21) is provided with means for transducing in the form of a muscle contraction sensor, or in the form of means for sampling cervical fluid or other changes in the vaginal environment, or in the form of means for sensing at least one of temperature, pH, secretion viscosity, vaginal pathogens and atypical cervical cells.

- 10 -

4. A system according to any of claims 1-3, characterized in that said probe (21) is a sealed unit which is inserted "in-situ" into the vaginal vault or removed therefrom, and in that said controller (22) may be a hand-held unit.

5
5. A system according to any of claims 1-3, characterized in that said means of said controller and transceiver (22) for sending signals includes means (36') for wirelessly altering at least one of stimulation signal levels and medication, and/or in that said probe (21) is provided with stimulating means that includes means for automatic adjustment of stimulation levels in response to at least one of sensed muscle contractions and changes in the vaginal environment.

10
6. A system according to any of claims 1-5, characterized in that said probe (21) is provided with stimulating means, and in that said stimulating means is programmed to provide at least one of increasing stimulation and medication over a given period of time, wherein said stimulating means may be remotely adjustable via a wireless signal.

15
7. A system according to any of claims 1-6, characterized in that said probe (21) is provided with at least one of at least one conductive band (26) and a sensor transducer.

20
8. A system according to any of claims 1-7, characterized in that said controller and said probe are provided with a wireless means to transmit signals to and/or receive signals from external devices, networks, or databases.

25
9. A method of accomplishing at least one of transducing vaginal conditions, affecting vaginal or body conditions, and stimulating perineal musculature and nerves, said method characterized by the steps of:

- 11 -

intravaginally inserting a portable, combination probe and transceiver (21);

5 with said combination probe and transceiver (21) accomplishing at least one of transducing vaginal conditions, delivering signals or medication, and stimulating perineal musculature and nerves;

10 providing said combination probe and transceiver (21) with 2-way wireless communication means (36') for transmitting transduced information and for receiving control and programming signals;

providing a separate combination controller and transceiver (22) that is provided with wireless means (36') for sending signals to said combination probe and transceiver (21) and for receiving signals therefrom; and

15 providing a wireless signal feedback loop between said combination probe and transceiver (21) on the one hand and said combination controller and transceiver (22) on the other hand.

20 10. A method according to claim 9, characterized by the step of transmitting and/or receiving signals, in a wireless manner, to and from external devices, networks or databases.

1/5

FIG 1

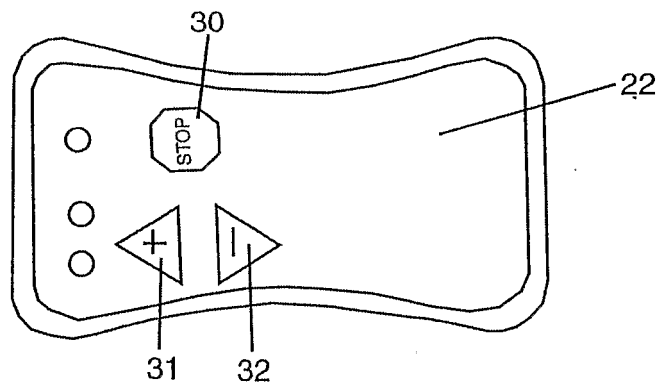
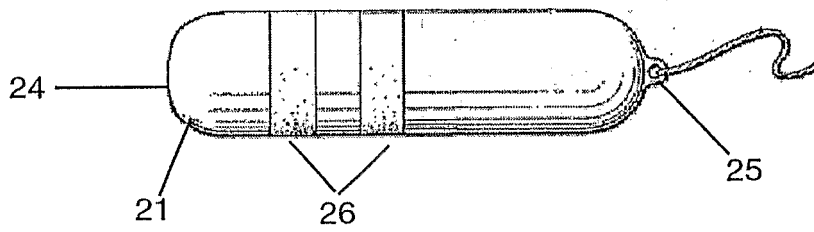
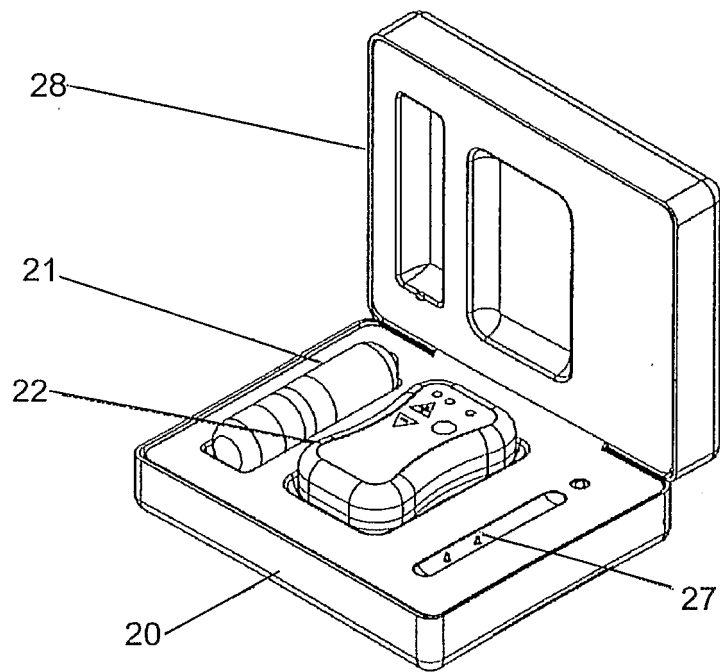

FIG 2

FIG 3



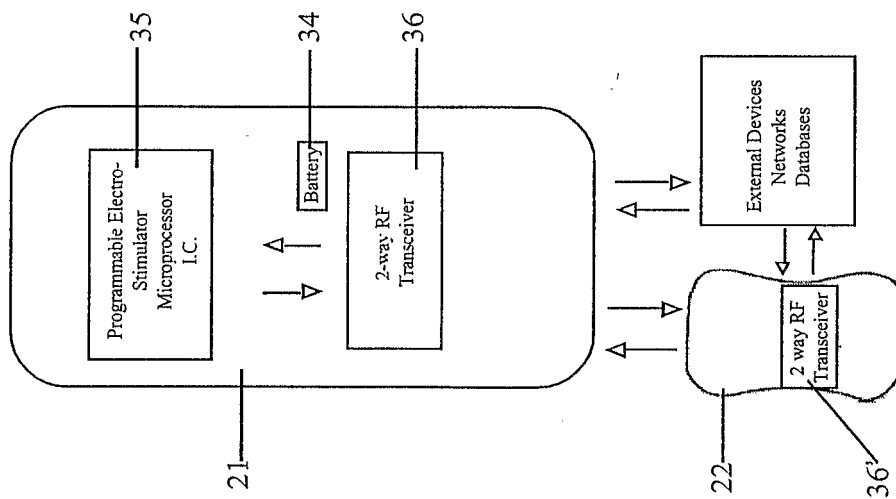

FIG. 4

FIG 5

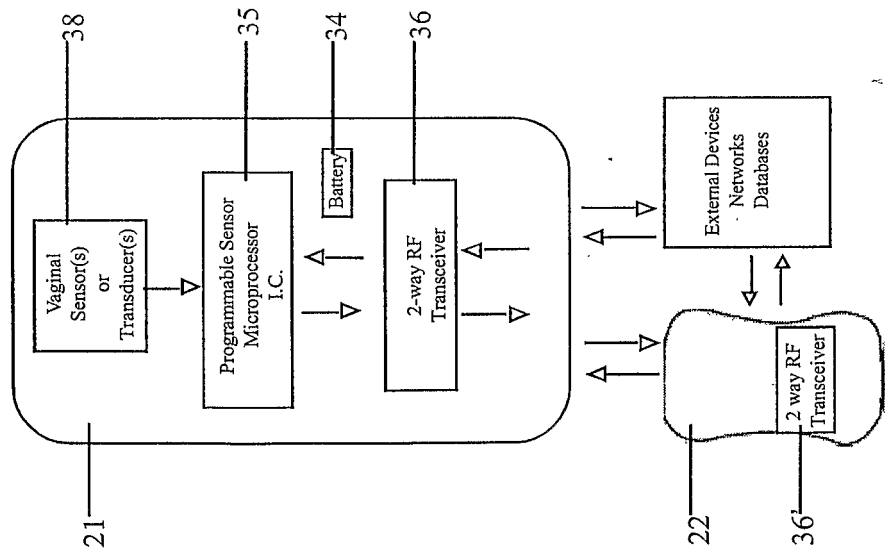
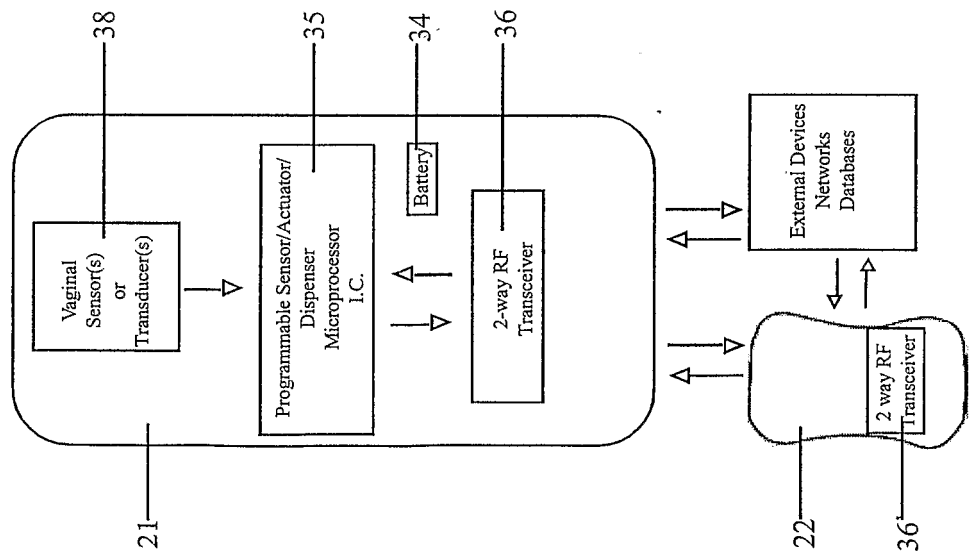

FIG 6



INTERNATIONAL SEARCH REPORT

International application No.

PCT/US02/34245

A. CLASSIFICATION OF SUBJECT MATTER

IPC(7) : A61B 5/103
 US CL : 600/591

According to International Patent Classification (IPC) or to both national classification and IPC

B. FIELDS SEARCHED

Minimum documentation searched (classification system followed by classification symbols)
 U.S. : 600/29, 38, 300, 373, 546, 549, 587, 591; 607/116, 138; 128/903

Documentation searched other than minimum documentation to the extent that such documents are included in the fields searched

Electronic data base consulted during the international search (name of data base and, where practicable, search terms used)
 Please See Continuation Sheet

C. DOCUMENTS CONSIDERED TO BE RELEVANT

Category *	Citation of document, with indication, where appropriate, of the relevant passages	Relevant to claim No.
X	US 4,515,167 A (HOCHMAN) 07 May 1985, see entire document.	1-10
A	US 6,432,037 B1 (EINI et al) 13 August 2002, see entire document.	1-10
A	US 6,086,549 A (NEESE et al) 11 July 2000, see entire document.	1-10
A	US 5,233,987 A (FABIAN et al) 10 August 1993, see entire document.	1-10

Further documents are listed in the continuation of Box C.

See patent family annex.

* Special categories of cited documents:		
"A"	document defining the general state of the art which is not considered to be of particular relevance	"T" later document published after the international filing date or priority date and not in conflict with the application but cited to understand the principle or theory underlying the invention
"E"	earlier application or patent published on or after the international filing date	"X" document of particular relevance; the claimed invention cannot be considered novel or cannot be considered to involve an inventive step when the document is taken alone
"L"	document which may throw doubts on priority claim(s) or which is cited to establish the publication date of another citation or other special reason (as specified)	"Y" document of particular relevance; the claimed invention cannot be considered to involve an inventive step when the document is combined with one or more other such documents, such combination being obvious to a person skilled in the art
"O"	document referring to an oral disclosure, use, exhibition or other means	"&" document member of the same patent family
"P"	document published prior to the international filing date but later than the priority date claimed	

Date of the actual completion of the international search

29 January 2003 (29.01.2003)

Date of mailing of the international search report

03 MAR 2003

Name and mailing address of the ISA/US
 Commissioner of Patents and Trademarks
 Box PCT
 Washington, D.C. 20231

Facsimile No. (703)305-3230

Authorized officer

Charles A. Marmor, II

Telephone No. (703) 308-0858

INTERNATIONAL SEARCH REPORT

International application No.

PCT/US02/34245

Box I Observations where certain claims were found unsearchable (Continuation of Item 1 of first sheet)

This international report has not been established in respect of certain claims under Article 17(2)(a) for the following reasons:

1. Claim Nos.:
because they relate to subject matter not required to be searched by this Authority, namely:

2. Claim Nos.:
because they relate to parts of the international application that do not comply with the prescribed requirements to such an extent that no meaningful international search can be carried out, specifically:

3. Claim Nos.:
because they are dependent claims and are not drafted in accordance with the second and third sentences of Rule 6.4(a).

Box II Observations where unity of invention is lacking (Continuation of Item 2 of first sheet)

This International Searching Authority found multiple inventions in this international application, as follows:

1. As all required additional search fees were timely paid by the applicant, this international search report covers all searchable claims.
2. As all searchable claims could be searched without effort justifying an additional fee, this Authority did not invite payment of any additional fee.
3. As only some of the required additional search fees were timely paid by the applicant, this international search report covers only those claims for which fees were paid, specifically claims Nos.:

4. No required additional search fees were timely paid by the applicant. Consequently, this international search report is restricted to the invention first mentioned in the claims; it is covered by claims Nos.:

Remark on Protest

The additional search fees were accompanied by the applicant's protest.

No protest accompanied the payment of additional search fees.

INTERNATIONAL SEARCH REPORT

PCT/US02/34245

Continuation of Item 4 of the first sheet:

The Title is too long under PCT Rule 4.3. NEW TITLE:

VAGINAL SENSING AND STIMULATING USING 2-WAY WIRELESS COMMUNICATIONS

Continuation of B. FIELDS SEARCHED Item 3:

EAST

search terms: vaginal, probe, controller, telemetry, telemetric, transducer, wireless, sensing, stimulating, sensor, muscle, temperature, pH, secretion viscosity, pathogens, cervical cells

专利名称(译)	使用双向无线通信进行阴道感知和刺激		
公开(公告)号	EP1487335A1	公开(公告)日	2004-12-22
申请号	EP2002784285	申请日	2002-10-24
[标]申请(专利权)人(译)	雅典娜費米尼技術有限公司		
申请(专利权)人(译)	ATHENA FEMININE TECHNOLOGIES , INC.		
当前申请(专利权)人(译)	ATHENA FEMININE TECHNOLOGIES , INC.		
[标]发明人	HOCHMAN JOEL S SARKIS GEORGE		
发明人	HOCHMAN, JOEL, S. SARKIS, GEORGE		
IPC分类号	A61B A61B5/00 A61B5/103 A61N1/36		
CPC分类号	A61B5/0002 A61B5/01 A61B5/04 A61B5/14539 A61B5/227 A61B5/4337 A61B10/0045 A61B2010/0019 A61B2010/0022 A61B2010/0074 A61B2562/242 A61H2201/5097 A61N1/0524 A61N1/36007		
其他公开文献	EP1487335A4 EP1487335B1		
外部链接	Espacenet		

摘要(译)

提供了一种系统和方法，用于转导阴道病症，影响阴道或身体状况，和/或刺激会阴肌肉组织和神经。提供了单独的，便携式，非植入的阴道内可容纳的组合探针和收发器（21），其可以感测阴道状况，可以递送信号或药物，和/或可以刺激会阴肌肉组织和神经。该探测单元具有双向无线通信，用于发送被转换的信息以及用于接收控制和编程信号的信息。另外，提供单独的组合控制器和收发器（22），用于无线地向探测器单元发送信号并从其接收信号。因此，在控制器和探针和/或外部设备，网络和数据库之间提供实时无线信号反馈回路。