



(11) **EP 1 956 969 B1**

(12) **EUROPEAN PATENT SPECIFICATION**

(45) Date of publication and mention of the grant of the patent:
02.11.2011 Bulletin 2011/44

(51) Int Cl.:
A61B 5/00 (2006.01) **A61B 5/15** (2006.01)
A61J 1/05 (2006.01) **B01L 3/14** (2006.01)
B65D 47/36 (2006.01) **B65D 81/32** (2006.01)

(21) Application number: **06846923.8**

(86) International application number:
PCT/CA2006/002009

(22) Date of filing: **11.12.2006**

(87) International publication number:
WO 2007/068094 (21.06.2007 Gazette 2007/25)

(54) **CONTAINER SYSTEM FOR RELEASABLY STORING A SUBSTANCE**

BEHÄLTERSYSTEM ZUR LAGERUNG UND LEICHTEN AUSGABE EINER SUBSTANZ
SYSTÈME DE CONTENANT POUR STOCKER UNE SUBSTANCE DE FAÇON LIBÉRABLE

(84) Designated Contracting States:
AT BE BG CH CY CZ DE DK EE ES FI FR GB GR HU IE IS IT LI LT LU LV MC NL PL PT RO SE SI SK TR

- **SUNSTRUM, Roy**
Richmond, Ontario K0A 2Z0 (CA)
- **LEM, Paul**
Ottawa, Ontario K1N 8Y3 (CA)
- **BIRNBOIM, H. Chaim**
Ottawa, Ontario K1H 6P2 (CA)

(30) Priority: **09.12.2005 US 748977 P**

(43) Date of publication of application:
20.08.2008 Bulletin 2008/34

(74) Representative: **Jump, Timothy John Simon et al**
Venner Shipley LLP
20 Little Britain
London
EC1A 7DH (GB)

(73) Proprietor: **DNA Genotek Inc.**
Ottawa, Ontario K2G 5W6 (CA)

(72) Inventors:

- **MUIR, Rod**
South Mountain, Ontario K0E 1W0 (CA)
- **KIRKLAND, Derek**
Chelsea, Quebec J9B 2E8 (CA)
- **CURRY, Ian**
Kanata, Ontario K2K 1X7 (CA)

(56) References cited:
EP-A2- 0 273 015 **WO-A1-97/21605**
WO-A1-97/48492 **WO-A1-2004/033336**
US-A- 4 583 971 **US-A- 4 741 346**
US-A- 5 567 309 **US-A- 5 980 834**
US-A- 6 138 821 **US-A1- 2004 200 742**
US-B1- 6 582 415

EP 1 956 969 B1

Note: Within nine months of the publication of the mention of the grant of the European patent in the European Patent Bulletin, any person may give notice to the European Patent Office of opposition to that patent, in accordance with the Implementing Regulations. Notice of opposition shall not be deemed to have been filed until the opposition fee has been paid. (Art. 99(1) European Patent Convention).

Description**RELATED APPLICATION**

[0001] This application claims priority to United States Application Serial No. 60/748,977 filed on December 9, 2005.

FIELD OF THE INVENTION

[0002] The field of the invention generally relates to a container system for releasably storing a substance.

BACKGROUND

[0003] It is often desirable to store a substance, such as a liquid, solid, gas, mixtures thereof, or the like, in a container prior to mixing the contents of the container with another material. For example, it may be desirable to package and store a compound, or compounds, in a container for shipping and/or safe storage and handling, prior to combining the compound(s) with another material. It may be desirable to package and store a toxic compound in a container, prior to combining such a toxic compound with a detoxifying material. As well, it is often desirable to keep a concentrated active ingredient separate from a diluent until immediately prior to use.

[0004] Moreover, it may be desirable to store and/or ship diagnostic and/or nucleic acid preserving compositions prior to combining such a substance with a biological sample.

[0005] Additionally, it may be desirable to keep a substance isolated from a donor until the donor's biological sample has been collected. This will help to prevent the donor from accidentally ingesting or spilling the substance.

[0006] It may also be desirable to inactivate pathogens/infecrious particles in a biological sample by combining it with a stored substance prior to storage and/or shipping and/or handling of the sample.

[0007] It may also be desirable to store and/or ship diagnostic and/or nucleic acid preserving compositions after combining such a substance with a biological sample.

[0008] There are a variety of containers for holding substances separately in such a manner that a user may open a closure to combine the substances. Typically these containers are double compartment systems in which substances are stored separately and substances are combined by removal of the container closures by a user.

[0009] US 6 138 821 discloses such a container system used in the beverage field.

[0010] International PCT application WO 2003/104251 describes a container for collecting a biological sample from a subject, and subsequently mixing the collected sample with a composition intended to stabilize, preserve, or facilitate the recovery of components

of the sample. This container has a first region for collecting a biological sample, a second region containing a composition for preserving a nucleic acid, and a barrier between the first region and the second region, which when in a closed position, maintains the sample and composition separate. The exemplified barrier of WO 2003/104251 is a pivoting partition. Attachment of a lid to the container forces the barrier to pivot from its original closed position spanning the container and thereby separating the first region and the second region, to an open position in which both regions are exposed to each other and contact between the composition contained in one region space and the biological sample contained in the other region is allowed. A drawback of this container is that it includes multiple parts (e.g., lid, vial, disk, rod, rod holder), which increases the cost of manufacture of the container. Additionally, because the disk is held in place by friction fit, there must be a high degree of precision for the manufacture of the components of the container.

[0011] There remains a need for an improved container system for releasably and reliably storing a substance.

[0012] This background information is provided for the purpose of making known information believed by the applicant to be of possible relevance to the present invention. No admission is necessarily intended, nor should be construed, that any of the preceding information constitutes prior art against the present invention.

SUMMARY OF THE INVENTION

[0013] The present invention generally relates to a container system for releasably storing a substance.

[0014] In accordance with one aspect of the present invention, there is provided a container system for releasably storing a liquid, comprising:

(a) a vial comprising a first open end for receiving a sample, a second end comprising a sample storage chamber and a piercing member, wherein said piercing member comprises a side wall, and a first cutting edge extending from a first pointed corner to a second corner that defines the intersection between said cutting edge and said side wall; and

(b) a lid configured to removably engage said vial, said lid comprising a reservoir for holding the liquid, and a pierceable membrane sealing the liquid within said reservoir; wherein, when said system is closed by removable engagement of said vial with said lid, said vial and said lid are movable to a piercing position in which the piercing member disrupts the pierceable membrane to allow fluid communication between said reservoir and said chamber, wherein the chamber is sealed against leakage to the outside of the container system in the piercing position.

[0015] In accordance with another aspect of the present invention, there is provided a container system for releasably storing a liquid, comprising:

(a) a vial comprising a chamber for retaining a sample;

(b) a lid comprising a reservoir for holding the liquid, and a pierceable membrane sealing the liquid within said reservoir; and

(c) a funnel comprising a first open end for receiving said sample, a piercing member and a channel extending from said first open end to a second open end and being in fluid communication with said chamber, said funnel being removably attachable to said lid at said first open end and releasably or permanently attached to said vial at said second end, and wherein said piercing member comprises a side wall, and a first cutting edge extending from a first pointed corner to a second corner that defines the intersection between said cutting edge and said side wall;

wherein, when said system is closed by removable attachment of said lid to said funnel, said system is movable to a piercing position in which the piercing member disrupts the pierceable membrane to allow fluid communication between said reservoir and said chamber, via said channel, wherein the chamber is sealed against leakage to the outside of the container system in the piercing position.

[0016] In accordance with another aspect of the present invention, there is provided a method of combining a liquid with a biological sample, comprising:

(I)

(a) providing a container system according to claim 1 or 2;

(b) providing the sample to the chamber in the vial; and

(c) closing said container system by removably attaching said lid to said vial; and

(d) piercing said membrane to release said liquid into said chamber by moving said lid and said vial to said piercing position; or

(II)

(a) providing a container system according to claim 3 or 4;

(b) providing the sample to the chamber in the vial through said funnel; and

(c) closing said container system by removably attaching said lid to said first open end of said funnel; and

(d) piercing said membrane to release said liquid into said chamber by moving said system to said piercing position.

[0017] In accordance with another aspect of the present invention there is provided a kit for releasably storing a substance comprising: a) a container system

as described herein; and b) instructions for the use thereof.

BRIEF DESCRIPTION OF THE FIGURES

[0018]

Figure 1 is a cross-sectional view of a container system in accordance with one embodiment of the present invention, showing the lid and vial attached;

Figure 2 is a perspective view of the interior of the lid of the container system depicted in Figure 1;

Figure 3 is a perspective view of the interior of the vial of the container system depicted in Figure 1;

Figure 4 is a perspective view of a container system in accordance with one embodiment of the present invention;

Figure 5 is a top view of the container system depicted in Figure 4;

Figure 6 is a side view of the container system depicted in Figure 4;

Figure 7 is a side view of the container system depicted in Figure 4;

Figure 8 is a bottom view of the container system depicted in Figure 4;

Figure 9 is a cross-sectional view of the container system of Figure 4 taken along line A-A in Figure 5;

Figure 10 is a top perspective view of the container system depicted in Figure 4 showing the lid and vial separated;

Figure 11 is a bottom perspective view of the container system depicted in Figure 4 showing the lid and vial separated;

Figure 12 is a side perspective view a container system in accordance with one embodiment of the present invention;

Figure 13 is a top view of the container system depicted in Figure 12;

Figure 14 is a bottom view of the container system depicted in Figure 12;

Figure 15 is a side view of the container system depicted in Figure 12;

Figure 16 is a cross-sectional view of the container

system of Figure 12 taken along line B-B in Figure 15;

Figure 17 is a side perspective view of the container system depicted in Figure 12;

Figure 18 is a top perspective view of the container system depicted in Figure 12, showing the lid and funnel separated;

Figure 19 is a bottom side perspective view of the container system depicted in Figure 12, showing the lid and funnel separated;

Figure 20 is a side view of the vial and cap of the container system depicted in Figure 9;

Figure 21 is a side view of the container system depicted in Figure 12, showing the lid, funnel, and vial separated;

Figure 22 is a side perspective view a container system in accordance with one embodiment of the present invention;

Figure 23 is a top perspective view of the vial portion of the container system depicted in Figure 22, showing the vial; and

Figure 24 is a cross-sectional view of the lid of the container system depicted in Figure 22.

[0019] The numbers in bold face type serve to identify the component parts that are described and referred to in relation to the drawings depicting various embodiments of the present invention. It should be noted that in describing various embodiments of the present invention, the same reference numerals have been used to identify the same or similar elements. Moreover, for the sake of simplicity, parts have been omitted from some figures of the drawings.

DETAILED DESCRIPTION OF THE INVENTION

[0020] As will be discussed in more detail below, the present invention provides a container system for releasably storing a substance.

[0021] The container system of the present invention has fewer parts and, thus, is less expensive and/or easier to manufacture, than previous containers. Additionally, the manufacturing tolerances can be less precise for the container system of the present invention, as compared to previous containers having separable compartments. Again, this reduces manufacturing cost, and makes accidental disruption of a sealed substance less likely. Additionally, in one example of the present invention, the container system includes a removable vial which is suitable for subsequent processing of samples and/or for use in robotic systems.

[0022] The container system of the present invention comprises a vial and a lid. Optionally, the container system additionally comprises a funnel that is permanently or removably attached to the vial and that sealingly engages the lid. The lid is configured to store a substance, and subsequently release the substance from the lid when the lid is sealingly attached to the vial, or the funnel. In use, the substance stored within the lid is released into the vial when the lid is attached to the vial or the funnel, if present.

[0023] In accordance with a specific embodiment of the present invention, the lid is suitable to store a substance to stabilize, preserve or facilitate the recovery of nucleic acid from a biological sample. In accordance with a related embodiment, the vial, or the combination of the funnel and vial is suitable for the collection of a biological sample from a subject.

[0024] Referring to the Figures 1-11 and 22-24, container system **300** comprises lid **100** and vial **1**.

LID

[0025] Lid **100** releasably stores a substance. Lid **100** is generally cylindrically shaped with at least one open end. Lid **100** can be a variety of shapes, as determined by the needs or preferences of the user and/or the intended application of use. The interior of lid **100** includes wall **104** that is positioned within lid **100** and defines reservoir **102** for holding a substance such as a liquid, solid, semi-solid, gas, mixtures thereof and the like. Wall **104** defines all or a portion of the perimeter of reservoir **102**. Wall **104** includes sealing surface **106** which is for sealingly attaching pierceable membrane **160**

[0026] Pierceable membrane **160** (depicted in Figure 19) acts as a physical barrier to releasably store a substance within reservoir **102**, when attached to sealing surface **106**. Pierceable membrane **160** is made from material that is inert to the substance to be stored within the reservoir. Pierceable membrane **160** permits little or no diffusion of the substance through pierceable membrane **160** over time. Pierceable membrane **160** is made from a material that is suitable for the intended processing, storage and/or transportation conditions. In a specific embodiment, pierceable membrane **160** is heat and cold resistant such that it remains intact and pierceable at temperatures ranging from about -80°C to about +70°C. In a specific embodiment, pierceable membrane **160** can be attached tightly enough to sealing surface **106** such that pierceable membrane **160** will not be disrupted by vacuum pressures. Pierceable membrane **160** can be made from a variety of materials including polypropylene. Desirably, pierceable membrane **160** is made from the same material as wall **104**. The thickness of pierceable membrane **160** can vary according to application of use, and preference of the user. Desirably, pierceable membrane **160** has a thickness of about two thousandths of an inch. However, the specific thickness of the membrane will be determined by factors such as, nature of

the substance, nature of the sample, overall dimensions of the container system and chemical composition of the membrane.

[0027] A variety of methods of attaching pierceable membrane **160** to sealing surface **106** can be used, and is dependent on the material used to make lid **100**, the substance stored within reservoir **102**, and/or the characteristics of membrane **160**. Such methods of attachment include use of adhesive(s), heat-sealing treatment, fasteners, or any combination thereof, and the like. Desirably, heat-sealing is used to attach pierceable membrane **160** to sealing surface **106**. As will be clear to the skilled worker, the type of pierceable membrane, the physical and/or chemical properties of the pierceable membrane will be dependent upon, in part, the composition to be stored. Desirably pierceable membrane **160** is inert with respect to the intended use, stored substance and sample of the container system.

[0028] In the specific embodiments depicted in the Figures, lid **100** comprises internal helical threads **108** on the inner surface of outer wall **110**, which are adapted to engage external helical threads **18** on the outer surface of wall **12** on vial **1**. As would be appreciated by a skilled worker, alternative means for releasable attachment of lid **100** to vial **1** can be used in the container system of the present invention, provided that lid **100** and vial **1** are movable to a piercing position, as discussed in greater detail below.

[0029] Lid **100** and reservoir **102** can be sized to accommodate a range of volumes of a substance. In the specific embodiment in which the substance is a nucleic acid preservative for use with a saliva sample, reservoir **102** accommodates about **1** ml to about **4** ml of a substance. The choice of material used to manufacture lid **100** is dependent upon a number of factors including manufacturing constraints, chemical suitability, and the like. In the specific embodiment in which the substance is a nucleic acid preservative for use with a saliva sample, lid **100** is made from plastics such as polypropylene, medium-density polyethylene (MDPE), high-density polyethylene (HDPE), polyethylene and the like. Desirably, lid **100** is polypropylene. The materials of lid **100** may be opaque, transparent or translucent, depending on the desired application. For example, an opaque material can be used to store a light sensitive composition(s). A transparent or translucent material is desirable if a visual (e.g., colour) indicator is present in the stored substance. Lid **100** and reservoir **102** can be manufactured to include gradations to demarcate the quantity of the substance stored within reservoir **102**. The outer surface of lid **100** can also include a labelling area for a user to identify the contents of the lid. The outer surface of lid **100** may also include a region to affix or emboss a logo and/or other markings.

[0030] In accordance with one embodiment of the present invention, wall **104** has a generally cylindrical shape sized to fit within the interior of lid **100**. It will be clear that the shape and size of well **104** is dependent

upon the intended use of the container system. Lid **100** may be constructed from a single piece of material that includes wall **104**, or wall **104** may be removably attached to lid **100**. Desirably, lid **100** is formed from a single piece of material.

VIAL

[0031] In accordance with one embodiment of the present invention, vial **1** is generally cylindrically shaped with at least one open end. Vial **1** can be a variety of shapes, as determined by the needs or preferences of the user and/or application of use. The interior of vial **1** comprises chamber **2** for receiving a sample such as a liquid, solid, semi-solid, mixtures thereof and the like. Desirably, chamber **2** is configured to receive a biological sample, for example a sputum sample, such as saliva.

[0032] Vial **1** comprises a first open end for receiving said sample, and a second end comprising chamber **2**. In one example, said second end is a second closed end. In another example, said second end is a second open end.

[0033] In one example, the width of the first open end of vial **1** is approximately equivalent to the Width of the second end.

[0034] In another example, the first open end of vial **1** is generally wider than the second end vial **1**. In this example, the generally wider first open end facilitates sample collection by, for example, acting similar to a funnel.

[0035] In accordance with one embodiment, and as shown in Figure 22-24, container system **300** comprises a funnel fixedly attached to, or integral with, vial **1**. In the case in which the funnel is fixedly attached to, or integral with vial **1**, it can also be characterised as a vial having a wide mouth opening for receiving a sample. The wide mouth or funnel characteristics can make it easier for a subject to provide a sample.

[0036] Vial **1** and chamber **2** can be sized to accommodate a range of volumes of a sample. In the specific embodiment in which the substance is a nucleic acid preservative for use with a saliva sample, chamber **2** accommodates about **1** ml to about **4** ml of a sample. In another specific embodiment, chamber **2** accommodates about **1** ml to about **16** ml of a sample.

[0037] Vial **1** comprises at least one piercing member **6**. In the specific embodiment depicted in Figures 1-11 piercing member **6** extends from a base surface of chamber **2**. In one example, piercing member **6** extends approximately perpendicular from the base. In another example, piercing member **6** is angled inwardly or outwardly toward the open end of vial **1**. Alternatively, piercing member **6** extends from an interior surface of said vial. In one example, piercing member **6** extends from an interior surface of said vial and is angled inwardly or outwardly toward the open end of vial **1**.

[0038] In one example, there is one piercing member **6** within chamber **2**. In an alternative example, there is a plurality of piercing members **6**, for example, two piercing

members, three piercing members or more than three piercing members. In one example the piercing members are arranged in a generally semicircular fashion. In a specific example, in the case of three piercing members, the piercing members are arranged in a generally semicircular fashion, as depicted in Figure 9, 10 and 23.

[0039] According to the invention, the piercing member 6 can be approximately trapezoidal in shape and includes first cutting edge 33 having pointed end 30 at one corner of the trapezoid and a second end at a second corner of the trapezoid where cutting edge 32 intersects side wall 34. Optionally, side wall 34 also includes cutting edge 33, which extends from cutting edge 32.

[0040] Container system 300 further includes a means for sealing attachment of lid 1 to vial 100. Such sealing means act to ensure that the contents of vial 1 remain sealed with chamber 2 when lid 100 is attached to vial 1.

[0041] In one example, lid 100 and vial 1 are movable between an open position and a piercing position. In a specific example, lid 100 is initially attached to vial 1 by threadingly engaging internal and external threads 108 and 18 with a twisting motion. Initially, lid 100 and vial 1 are threadingly connected, but piercing member 6 does not disrupt pierceable membrane 160 and end portion 30 of wall 12 engages sealing wall 120. For example, as depicted in Figure 9, sealing wall 120 extends downwardly and outwardly from the interior of lid 100. This type of sealing mechanism is similar to a wipe seal that would be well known to the skilled worker. Thus, initially, chamber 2 is maintained out of fluid communication with reservoir 102 by pierceable membrane 160.

[0042] In an alternate example, lid 100 and vial 1 are movable between a first position and a piercing position. In a specific example, lid 100 is initially attached to vial 1 by threadingly engaging internal and external threads 108 and 18 with a twisting motion and thereby moved to the first position. In moving lid 100 and vial 1 to the first position, lid 100 and vial 1 are threadingly connected, but piercing member 6 does not disrupt pierceable membrane 160. In the first position, end portion 30 of wall 12 sealingly engages sealing wall 120. For example, as depicted in Figure 9, sealing wall 120 extends downwardly and outwardly from the interior of lid 100. This type of sealing mechanism is similar to a wipe seal that would be well known to the skilled worker. Thus, in the first position, chamber 2 is sealed against leakage to the outside of the container system by sealing engagement of wall 12 with sealing wall 120 and maintained out of fluid communication with reservoir 102 by pierceable membrane 160.

[0043] A worker skilled in the art will recognize that there are known alternative sealing structures that can be incorporated into the present system for ensuring that chamber 2 is sealed against leakage to the outside of the container system. Such alternatives are considered to be within the scope of the present invention.

[0044] Continued twisting moves lid 100 and vial 1 from the open position, or the first position, to the piercing po-

sition, in which movement of lid 100 and vial 1 together results in disruption of pierceable membrane 160 by piercing member 6, and the release of the substance within reservoir 102 into chamber 2.

5 [0045] In operation, in moving to the piercing position, pointed end 31 of piercing member 6 is brought into contact with pierceable membrane 160 and pierces pierceable membrane 160. Continued twisting moves cutting edge 32 through pierceable membrane 160, disrupting pierceable membrane 160, and thereby producing an opening in the sealing membrane to enable the substance to enter chamber 2. It will be clear that if more than one piercing member is present, less twisting of lid 100 and vial 1 is required to generate an opening. When three piercing members are present, a suitable opening is obtainable in about one quarter of a turn. Desirably, pierceable membrane 160 is not completely removed from sealing surface 106. Thus, in the piercing position, piercing member 6 disrupts pierceable membrane 160 to allow fluid communication between reservoir 102 and chamber 2.

10 [0046] The distance between piercing member 6 and wall 104 will vary according to the needs and preferences of the user. The distance between piercing member 6 and wall 104 can vary from being generally flush with one another, to being generally separated from one another.

15 [0047] It will be clear to the skilled worker that length, rigidity and the like, of piercing member 6 is selected such that it is sufficient to disrupt pierceable membrane 160 when lid 100 and vial 1 are in the piercing position, and not disrupt the pierceable membrane 160 when lid 100 and vial 1 are in the open or first position.

20 [0048] The choice of the material of vial 1 will be dependent upon a number of factors including manufacturing constraints, chemical suitability, and the like. Additionally, the construction material of lid 1 may be same or different as that used to make reservoir 6. In the specific embodiment in which the substance is a nucleic acid preservative for use with a saliva sample, vial 1 is made from plastics such as polypropylene, medium-density polyethylene (MDPE), high-density polyethylene (HDPE), polyethylene and the like. Desirably, vial 1 is HDPE.

25 [0049] In accordance with another aspect of the present invention, the container system comprises a lid, a funnel and a vial.

30 [0050] Referring to the Figures 12-21, container system 600 comprises lid 100 and funnel 400 and vial 500.

50 LID

[0051] Lid 100 releasably stores a substance, as described above.

55 FUNNEL

[0052] Funnel 400 includes a first open end for receiving a sample, a second open end for removable or fixed

attachment to vial **500**. In one embodiment, funnel **400** is integral with vial **500**. The interior of funnel **400** comprises interior channel **422** extending therethrough for maintaining the first open end and the second open end in fluid communication and for receiving a sample such as a liquid, solid, semi-solid, mixtures thereof and the like. Funnel **400** can be a variety of shapes, as determined by the needs or preferences of the user and/or application of use. Desirably, interior channel **422** is configured to receive a biological sample. For example, the biological sample is a sputum sample, such as saliva. Interior channel **422** can be sized accommodate a range of volumes of sample.

[0053] In the specific embodiments depicted in the Figures, lid **100** comprises internal helical threads **108** on the inner surface of outer wall **110**, which are adapted to engage external helical threads **418** on the outer surface of wall **412** on funnel **400**. As would be appreciated by a skilled worker, alternative means for releasable attachment of lid **100** to funnel **400** can be used in the container system of the present invention, provided that lid **100** and funnel **400** are movable to the piercing position, as discussed in greater detail above.

[0054] Funnel **400** comprises at least one piercing member **6**. In accordance with the embodiment depicted in Figures 12-21, piercing member **6** extends from an interior surface (interior side wall **420**) of funnel **400**. In one example, piercing member **6** is angled inwardly or outwardly toward pierceable membrane **160**. Other arrangements of piercing member **6** can be used, as would be readily appreciated by the skilled worker.

[0055] In one example, there is one piercing member **6** within interior channel **422**. In an alternative example there is a plurality of piercing members, for example, two piercing members, three piercing members or more than three piercing members. In the case of three piercing members, desirably the piercing members are arranged in a generally semicircular fashion, as shown in Figure 18.

[0056] As above, piercing member **6** can be approximately trapezoidal in shape and includes first cutting edge **33** having pointed end **30** at one corner of the trapezoid and a second end at a second corner of the trapezoid where cutting edge **32** intersects side wall **34**. Optionally, side wall **34** also includes cutting edge **33**, which extends from cutting edge **32**.

[0057] Container system **600** further includes a means for sealing attachment of lid **1** to funnel **400**. Such sealing means act to ensure that the contents of vial **1** remain sealed with chamber **2** when funnel **400** and vial **500** are attached to vial **1**.

[0058] Optionally, funnel **400** includes outwardly extending ribs **402** that can be used by a user to twist funnel **400** and lid **100**, and/or funnel **400** and vial **500**.

[0059] The choice of the material of funnel **400** will be dependent upon a number of factors including manufacturing constraints, chemical suitability, and the like. Additionally, the construction material of funnel **400** may be same or different as that used to make lid **100** and col-

lection vial **500**. In the specific embodiment in which the substance is a nucleic acid preservative for use with a saliva sample, funnel **400** is made from plastics such as polypropylene, high-density polyethylene (HDPE), polyethylene, medium-density polyethylene (MDPE), or any combination thereof, and the like. Desirably, vial **1** is HDPE.

[0060] In a specific example, lid **100** is polypropylene, vial **500** is polypropylene and funnel **400** is HDPE.

VIAL

[0061] Vial **500** (or collection vial **500**) is generally cylindrically shaped with an open end for removable or fixed attachment to the second end of funnel **400**, and chamber **530** for receiving a sample. Vial **500** can be a variety of shapes, as determined by the needs or preferences of the user and/or application of use, and can be specifically manufactured for use in the container system of the present invention or can be a commercially available vial. As noted above, and in one embodiment, funnel **400** is integral with vial **500**. When the container system is used for laboratory purposes, desirably, vial **500** is sized to fit within a standard test tube rack such as that typically used in biological sample processing. In one example, vial **500** conforms with industry-standard dimensions for blood collection tubes (e.g., 13 mm x 75 mm). Desirably vial **500** is suitable for use with robotic DNA purification systems (e.g., the Beckman BioMek™ FX). Desirably, vial **500** is commercially available from Simport Plastics Limited (e.g., the T501 tubes).

[0062] The open end of vial **500** is also configured for securing attachment with a standard cap **520**, as shown in Figure 21. Cap **520** can be secured by a threaded screw, snap-fit, and the like.

[0063] Vial **500** optionally includes surface **502** that is suitable for labelling and/or for providing friction for gripping by a user.

[0064] Vial **500** may be removably attached to funnel **400** using a variety of locking mechanisms. In accordance with one embodiment of the present invention, the locking mechanism is a helical threaded screw. Alternatively, the locking mechanism is a snap-fit. Alternatively, vial **500** is fixedly attached to or integral with, funnel **400**.

[0065] In one example, lid **100** and funnel **400** are movable between an open position and a piercing position, as discussed supra with lid **100** and vial **1**. In a specific example, lid **100** is initially attached to funnel **400** by threadingly engaging internal and external threads **108** and **18** with a twisting motion. Initially, lid **100** and funnel **400** are threadingly connected, but piercing member **6** does not disrupt pierceable membrane **160**, and end portion **30** of wall **12** engages sealing wall **120**. As depicted in Figures 9 and 16, sealing wall **120** extends downwardly and outwardly from the inner surface of lid **100**. This type of sealing mechanism is similar to a wipe seal, that would be well known to the skilled worker. Thus, initially, interior channel **422** is maintained out of fluid communication

with said reservoir **102** by pierceable membrane **6**.

[0066] In an alternate example, lid **100** and funnel **400** are movable between a first position and a piercing position, as discussed supra with lid **100** and vial **1**. Lid **100** is initially attached to funnel **400** by threadingly engaging internal and external threads **108** and **18** with a twisting motion. In moving lid **100** and funnel **400** to the first position, lid **100** and funnel **400** are threadingly connected, but piercing member **6** does not disrupt pierceable membrane **160**. In the first position, end portion **30** of wall **12** sealingly engages sealing wall **120**. As depicted in Figures 9 and 16, sealing wall **120** extends downwardly and outwardly from the inner surface of lid **100**. This type of sealing mechanism is similar to a wipe seal, that would be well know to the skilled worker. Thus, in the first position, interior channel **422** is sealed against leakage to the outside of the container system and maintained out of fluid communication with said reservoir **102** by pierceable membrane **6**.

[0067] Continued twisting moves lid **100** and funnel **400** from either the open position or the first position, to the piercing position, in which moving lid **100** and vial **1** together results in disruption of pierceable membrane **160** by piercing member **6**, and the release of the substance within reservoir **102** into chamber **2** and vial **500**.

[0068] In operation, in moving to the piercing position, pointed end **30** is brought into contact with pierceable membrane **160** and subsequently pierces pierceable membrane **160**. Continued twisting moves cutting edge **32** through pierceable membrane **160**, thereby disrupting pierceable membrane **160** and producing an opening in pierceable membrane **160** to permit the substance to enter interior channel **422**. If more than one piercing member is present, less twisting of lid **100** and vial **1** is required to generate an opening. When three piercing members are present, a suitable opening is obtainable in about one quarter of a turn. Thus, in the piercing position, piercing member **6** disrupts pierceable membrane **160** to allow fluid communication between reservoir **102** and interior channel **422**.

[0069] The distance between piercing member **6** and wall **104** will vary according to the needs and preferences of the user. The distance between piercing member **6** and wall **104** can vary from being generally flush with one another, to being generally separated from one another.

[0070] It will be clear to the skilled worker that length, rigidity and the like, of piercing member **6** is selected such that it sufficient to disrupt pierceable membrane **160** when lid **100** and vial **1** are in the piercing position, and not disrupt the pierceable membrane **160** when lid **100** and vial **1** are in the open or first position.

METHODS

[0071] According to one embodiment of the present invention, the container system of the present application is suitable for releasably storing a composition intended to stabilize, preserve, or facilitate the recovery of nucleic

acid from a biological sample. A biological sample can include bodily fluids and/or tissues.

[0072] Desirably, vial **1** and/or funnel **400** are sized for collecting a biological sample from a subject. Non-limiting examples of biological samples include skin, hair, fecal matter, bodily fluids, tissue, cells and the like.

[0073] The term "bodily fluid", as used herein, refers to a naturally occurring fluid from a human or an animal, such as saliva, sputum, serum, plasma, blood, pharyngeal, nasal/nasal pharyngeal and sinus secretions, urine, mucus, gastric juices, pancreatic juices, feces, semen, products of lactation or menstruation, tears, or lymph.

[0074] The term "bodily tissue" or "tissue", as used herein, refers to an aggregate of cells usually of a particular kind together with their intercellular substance that form one of the structural materials of a plant or an animal and that in animals include connective tissue, epithelium, muscle tissue, and nerve tissue, and the like.

[0075] The term "nucleic acid", as used herein, refers to a chain of nucleotides, including deoxyribonucleic acid (DNA) or ribonucleic acid (RNA), typically found in chromosomes, chromatin, mitochondria, ribosomes, cytoplasm, nucleus, microorganisms or viruses.

[0076] The term "ribonucleic acid" or "RNA", as used herein, refers to a wide range of RNA species, including, but not limited to high molecular RNA, large and small ribosomal RNAs, messenger RNA, pre-messenger RNA, small regulatory RNAs, RNA viruses (single and double-stranded, positive stranded or negative stranded) and the like. The RNA may be from a variety of sources, including, but not limited to human, non-human, viral, bacterial, fungal, protozoan, parasitic, single-celled, multi-cellular, in vitro, in vivo, natural, and/or synthetic sources.

[0077] Optionally the bodily fluid is saliva. The term "saliva", as used herein, refers to the secretion, or combination of secretions, from any of the salivary glands, including the parotid, submaxillary, and sublingual glands, optionally mixed with the secretions from the numerous small labial, buccal, and palatal glands that line the mouth.

[0078] The term "subject", as used herein, refers to an animal or human. Desirably, the subject is a mammal that can produce saliva for the purposes of nucleic acid stabilization and/or detection. Most desirably, the subject is human.

[0079] In use, a substance, such as a composition intended to stabilize, preserve, or facilitate the recovery of nucleic acid from a biological sample is sealed within reservoir **102** with a pierceable membrane. Suitable compositions include those described in International PCT application WO 2003/104251; International PCT application PCT/CA2006/000380; United States Application Serial Nos. 60/828,563; or 60/866,985, all of the contents of which are, hereby incorporated by reference in their entirety. Desirably the composition is Oragene™ DNA-preserving solution. Other suitable compositions would be well known to the skilled worker.

[0080] In use, in one example, a sample of saliva from a subject is placed within chamber 2 of vial 1. Alternatively, vial 500 is attached to funnel 400, and a sample of saliva is placed within chamber 2 of funnel 400.

[0081] To collect saliva from a subject, in one example, the subject is instructed to wait for a period of 30 - 60 minutes before last eating. If possible, the subject will brush his teeth (without using toothpaste). If possible, the subject will rinse his/her mouth with 50 ml of water. The subject will be requested to wait for 5-10 minutes to allow the mouth to clear of water. For subjects able to spit, they will be instructed to spit saliva into the special collection vial until the level of saliva reaches the 1 or 2 ml mark. Waiting after last eating and rinsing the mouth is desirable but not essential. Collection of saliva may take several minutes. If the subject finds that he/she is unable to deliver sufficient saliva, he/she will be given a few grains of table sugar to chew, and told not to be concerned if some of the sugar is spit into the vial. For subjects unable to spit (e.g., infants, young children, individuals with limitations/disabilities), an implement (e.g., swab, transfer pipette) may be used for sample collection. Similarly, a subject may be provided a liquid (e.g., mouthwash, water, saline) to gargle his/her mouth and throat or saline to flush his/her nasal cavity. Samples collected with said liquid would be delivered into the collection vial.

[0082] A substance, such as a composition to stabilize, preserve, and/or facilitate the recovery of nucleic acid and saliva is stored within reservoir 102 of lid 100.

[0083] Lid 100 is then attached to vial 1, moved to the piercing position, and the substance combines with the saliva in chamber 2.

[0084] Alternatively, lid 100 is attached to funnel 400, moved to the piercing position, and the substance combines with the saliva in interior 530.

[0085] The combination of the composition to stabilize, preserve, or facilitate the recovery of nucleic acid and saliva may then be used in standard nucleic acid testing reactions, for example for detection or quantitation. Alternatively, the combination may be stored within container system 300 or 600 and subsequently used, for example, for detection of nucleic acid contained within the saliva. Alternatively, funnel 400 is removed from vial 500, and cap 520 is attached to the open end of vial 500. In this example, the combination may be stored within vial 500 and subsequently used, for example, for detection of nucleic acid contained within the saliva.

[0086] In one aspect of the present invention container system 300 and container system 600 are sized for shipping. In one example, vial 1 and lid 100 of container system 300 are sized for shipping when securely attached. In one example lid 1, funnel 400 and collection vial 500 of container system 600, are sized for shipping when lid 1, funnel 400 and collection vial 500 are securely attached. In another example, vial 1 and lid 100 of Container system 300 are sized for shipping when vial 1 and lid 100 are separate. In another example, lid 1, funnel

400 and collection vial 500 of container system 600, are sized for shipping when lid 1, funnel 400 and collection vial 500 are separate. It will be appreciated that a variety of methods of shipping are contemplated. Non-limiting examples of shipping include shipping by hand, land, air, boat, animal, and the like, or combinations thereof. Desirably, container system 300 or container system 600 fit within a standard mail envelope. In one example, container system 300 or container system 600 fit within an envelope sized to fit within a standard European mail slot. In a specific example, the standard European mail slot has a width of about 3cm. Alternatively, container system 300 or container system 600 fit within an envelope sized to fit within a standard Canadian and/or United States of America mail slot.

[0087] Another aspect of the present invention provides a method of manufacture of a device for releasably storing a substance. The method of manufacture comprises providing container system in accordance with the present invention.

[0088] Another aspect of the present invention provides a method of combining a substance with a biological sample. This method comprises providing a container system in accordance with the present invention, wherein the container system includes the substance, and providing the biological sample.

[0089] Another aspect of the present invention provides a method of preserving nucleic acid in a biological sample. This method comprises providing a container system in accordance with the present invention, wherein the container system includes a substance for preserving nucleic acid in a biological sample.

[0090] Another aspect of the present invention provides a method of archiving a biological sample for prolonged periods of time. Desirably archiving is at room temperature. This method comprises providing a container system in accordance with the present invention and providing a substance for archiving the biological sample. In one example, prolonged storage is at room temperature for more than about one week, about two weeks, about three weeks, about one month, more than about one month, about one year.

KIT

[0091] Another aspect of the present invention provides a kit for collection of a sample and mixing the sample with a substance. The kit includes a container system in accordance with the present invention and instructions for the use thereof, optionally with a substance stored within the lid of the container system.

[0092] All publications, patents and patent applications mentioned in this Specification are indicative of the level of skill of those skilled in the art to which this invention pertains.

[0093] The invention being thus described, it will be obvious that the same may be varied in many ways. Such variations are not to be regarded as a departure from the

spirit and scope of the invention, and all such modifications as would be obvious to one skilled in the art are intended to be included within the scope of the following claims.

Claims

1. A container system for releasably storing a liquid, comprising:

(a) a vial (1) comprising a first open end for receiving a sample, a second end comprising a sample storage chamber (2) and a piercing member (6), wherein said piercing member (6) comprises a side wall, and a first cutting edge (33) extending from a first pointed corner to a second corner that defines the intersection between said cutting edge and said side wall; and
(b) a lid (100) configured to removably engage said vial (1), said lid comprising a reservoir for holding the liquid, and a pierceable membrane (160) sealing the liquid within said reservoir;

wherein, when said system is closed by removable engagement of said vial with said lid, said vial and said lid are movable to a piercing position in which the piercing member (6) disrupts the pierceable membrane (160) to allow fluid communication between said reservoir (102) and said chamber, wherein the chamber (2) is sealed against leakage to the outside of the container system in the piercing position.

2. A container system according to claim 1 wherein:-

(a) said lid comprises a wall defining all or a portion of the perimeter of said reservoir (102), said wall having a sealing surface for sealingly attaching said pierceable membrane (160);
(b) said reservoir (102) is configured to retain about 1 ml to about 4 ml of said liquid;
(c) said pierceable membrane (160) is inert;
(d) said pierceable membrane (160) remains intact and pierceable at temperatures of from about -80°C to about 70°C;
(e) said pierceable membrane is sealingly attached to said sealing surface by an adhesive, a heat-sealing treatment, a fastener, or any combinations thereof;
(f) the width of said first end is approximately equivalent to the width of said second end, or said first end is generally wider than said second end;
(g) said chamber (2) is configured to receive about 1 ml to about 16 ml, or about 1 ml to about 4 ml, of said sample;
(h) said piercing member (6) extends from a

base surface of said chamber (2) and, optionally, approximately perpendicularly from said base, or angled inwardly or outwardly toward said first open end of said vial;

(i) said side wall further includes a second cutting edge;

(j) said vial comprises a plurality of piercing members (6), optionally, two or three piercing members;

(k) said system comprises sealing means for sealing said chamber against leakage to the outside of said container system following movement of said container system to said piercing position, and said sealing means optionally comprise a sealing wall about the interior circumference of said lid that sealingly engages a surface of said vial when the system is in said piercing position; and/or

(l) said vial (1) and said lid (100) are sized for shipping in both an unattached state and an attached state.

3. A container system for releasably storing a liquid, comprising:

(a) a vial (500) comprising a chamber for retaining a sample;

(b) a lid (100) comprising a reservoir for holding the liquid, and a pierceable membrane sealing the liquid within said reservoir; and

(c) a funnel (400) comprising a first open end for receiving said sample, a piercing member and a channel extending from said first open end to a second open end and being in fluid communication with said chamber, said funnel (400) being removably attachable to said lid at said first open end and releasably or permanently attached to said vial at said second end, and wherein said piercing member (6) comprises a side wall, and a first cutting edge (33) extending from a first pointed corner to a second corner that defines the intersection between said cutting edge and said side wall (120); wherein, when said system is closed by removable attachment of said lid (100) to said funnel (400), said system is movable to a piercing position in which the piercing member disrupts the pierceable membrane to allow fluid communication between said reservoir and said chamber, via said channel, wherein the chamber is sealed against leakage to the outside of the container system in the piercing position.

4. A container system according to claim 3 wherein:-

(a) said lid comprises a wall (120) defining all or a portion of the perimeter of said reservoir and including a sealing surface for sealingly attach-

- ing said pierceable membrane;
 (b) said reservoir is configured to retain about 1 ml to about 4 ml of said liquid;
 (c) said pierceable membrane (160) is inert;
 (d) said pierceable membrane (160) maintain intact and pierceable at temperatures of from about -80°C to about 7°C;
 (e) said pierceable membrane (160) is sealingly attached to said sealing surface by an adhesive, a heat-sealing treatment, a fastener, or any combinations thereof;
 (f) said piercing member (6) extends from an interior surface of said funnel and, optionally, is angled inwardly or outwardly toward said first open end of said funnel;
 (g) said side wall optionally including a second cutting edge;
 (h) said funnel (400) comprises a plurality of piercing members (6), optionally two or three piercing members;
 (i) said system comprises sealing means for sealing said chamber against leakage to the outside of said container system, wherein said sealing means, optionally, comprises a sealing wall about the interior circumference of said lid that sealingly engages a surface of said funnel when the system is in the piercing position;
 (j) said vial (500) is releasably attached to said funnel (500) and sized for attachment to a cap when released from said funnel;
 (k) said vial is configured for use in standard laboratory equipment, optionally has dimensions that conforms with industry-standard dimensions for a blood collection tube, and preferably is a T501 tube; and/or,
 (l) said chamber is sized to hold about 1 ml to about 16 ml.
5. A container system according to any one of claims 1 - 4, wherein said liquid is a composition for the stabilization and recovery of a nucleic acid, optionally DNA or RNA, from a biological sample.
6. A container system according to any one of claims 1 - 5, additionally comprising a solid or semi-solid material within said vial and maintained separate from the liquid in the reservoir of said lid until said pierceable membrane is disrupted.
7. A method of combining a liquid with a biological sample, comprising:
- (I)
- (a) providing a container system according to claim 1 or 2;
 (b) providing the sample to the chamber in the vial; and
- (c) closing said container system by removably attaching said lid to said vial; and
 (d) piercing said membrane to release said liquid into said chamber by moving said lid and said vial to said piercing position; or
- (II)
- (a) providing a container system according to claim 3 or 4;
 (b) providing the sample to the chamber in the vial through said funnel; and
 (c) closing said container system by removably attaching said lid to said first open end of said funnel; and
 (d) piercing said membrane to release said liquid into said chamber by moving said system to said piercing position.
8. A method according to claim 7, wherein the liquid is a nucleic acid preserving liquid.
9. A method according to claim 7 or 8, wherein the sample is a biological sample.
10. A method according to any one of claims 7-9, for archiving the sample.
11. A kit for sample collection and storage, comprising:
- (a) a container system according to any one of claims 1 to 6; and
 (b) instructions for the use thereof.
- Patentansprüche**
1. Behältersystem zum freigebbaren Speichern einer Flüssigkeit, das Folgendes umfasst:
- (a) eine Phiolen (1) mit einem ersten offenen Ende zum Aufnehmen einer Probe, einem zweiten Ende mit einer Probenspeicherkammer (2) und einem Durchstechelement (6), wobei das genannte Durchstechelement (6) eine Seitenwand und eine erste Schneidkante (33) umfasst, die von einer ersten spitzen Ecke zu einer zweiten Ecke verläuft, die den Schnittpunkt zwischen der genannten Schneidkante und der genannten Seitenwand definiert; und
 (b) einen Deckel (100), der zum entfernbaren Eingreifen in die genannte Phiolen (1) konfiguriert ist, wobei der genannte Deckel ein Reservoir zum Aufnehmen der Flüssigkeit und eine durchstechbare Membran (160) umfasst, die die Flüssigkeit in dem genannten Reservoir einschließt;
- wobei, wenn das genannte System durch entfer-

bares Eingreifen der genannten Phiole mit dem genannten Deckel geschlossen wird, die genannte Phiole und der genannte Deckel in eine Durchstechposition bewegt werden können, in der das Durchstechelement (6) die durchstechbare Membran (160) durchbricht, um eine Fluidverbindung zwischen dem genannten Reservoir (102) und der genannten Kammer zu ermöglichen, wobei die Kammer (2) in der Durchstechposition gegen Auslaufen aus dem Behältersystem abgedichtet ist.

2. Behältersystem nach Anspruch 1, wobei:

- (a) der genannte Deckel eine Wand umfasst, die den Perimeter des genannten Reservoirs (102) ganz oder teilweise definiert, wobei die genannte Wand eine Dichtungsfläche zum dichtenden Anbringen der genannten durchstechbaren Membran (160) aufweist;
- (b) das genannte Reservoir (102) so konfiguriert ist, dass es etwa 1 ml bis etwa 4 ml der genannten Flüssigkeit aufnimmt;
- (c) die genannte durchstechbare Membran (160) inert ist;
- (d) die genannte durchstechbare Membran (160) bei Temperaturen von etwa -80°C bis etwa 70°C intakt und durchstechbar bleibt;
- (e) die genannte durchstechbare Membran mit einem Klebstoff, durch Heißsiegeln, mit einem Befestigungsmittel oder beliebigen Kombinationen davon dichtend an der genannten Dichtungsfläche angebracht wird;
- (f) die Breite des genannten ersten Endes etwa äquivalent mit der Breite des genannten zweiten Endes ist oder das genannte erste Ende allgemein breiter als das genannte zweite Ende ist;
- (g) die genannte Kammer (2) zum Aufnehmen von etwa 1 ml bis etwa 16 ml oder von etwa 1 ml bis etwa 4 ml der genannten Probe konfiguriert ist;
- (h) das genannte Durchstechelement (6) von einer Basisfläche der genannten Kammer (2) und optional etwa lotrecht von der genannten Basis oder schräg einwärts oder auswärts zu dem genannten offenen Ende der genannten Phiole hin verläuft;
- (i) die genannte Seitenwand ferner eine zweite Schneidkante beinhaltet;
- (j) die genannte Phiole mehrere Durchstechelemente (6), optional zwei oder drei Durchstechelemente umfasst;
- (k) das genannte System Dichtungsmittel zum Abdichten der genannten Kammer gegen Auslaufen aus dem genannten Behältersystem nach einer Bewegung des genannten Behältersystems in die genannte Durchstechposition umfasst und das genannte Dichtungsmittel optional eine Dichtungsrand um den Innenumfang

des genannten Deckels umfasst, der dichtend in eine Oberfläche der genannten Phiole eingreift, wenn das System in der genannten Durchstechposition ist; und/oder

(l) die genannte Phiole (1) und der genannte Deckel (100) für den Versand in einem unangebrachten Zustand und einem angebrachten Zustand bemessen sind.

3. Behältersystem zum freigebbaren Speichern einer Flüssigkeit, das Folgendes umfasst:

- (a) eine Phiole (500), die eine Kammer zum Aufnehmen einer Probe umfasst;
- (b) einen Deckel (100), der ein Reservoir zum Aufnehmen der Flüssigkeit umfasst, und eine durchstechbare Membran, die die Flüssigkeit in dem genannten Reservoir einschließt; und
- (c) einen Trichter (400), der ein offenes Ende zum Aufnehmen der genannten Probe umfasst, wobei ein Durchstechelement und ein Kanal von dem genannten ersten offenen Ende zu einem zweiten offenen Ende verläuft und in Fluidverbindung mit der genannten Kammer ist, wobei der genannte Trichter (400) entfernbar an dem genannten Deckel an dem genannten ersten offenen Ende angebracht und lösbar oder permanent an der genannten Phiole an dem genannten zweiten Ende angebracht werden kann, und wobei das genannte Durchstechelement (6) eine Seitenwand umfasst und wobei eine erste Schneidkante (33) von einer ersten spitzen Ecke zu einer zweiten Ecke verläuft, die den Schnittpunkt zwischen der genannten Schneidkante und der genannten Seitenwand (120) definiert; wobei das genannte System, wenn es durch entfernbares Anbringen des genannten Deckels (100) an dem genannten Trichter (400) geschlossen wird, in eine Durchstechposition bewegt werden kann, in der das Durchstechelement die durchstechbare Membran durchbricht, um eine Fluidverbindung zwischen dem genannten Reservoir und der genannten Kammer über den genannten Kanal zu ermöglichen, wobei die Kammer in der Durchstechposition gegen Auslaufen aus dem Behältersystem abgedichtet ist.

4. Behältersystem nach Anspruch 3, wobei:

- (a) der genannte Deckel eine Wand (120) umfasst, die den Perimeter des genannten Reservoirs ganz oder teilweise definiert und eine Dichtungsfläche zum dichtenden Anbringen der genannten durchstechbaren Membran aufweist;
- (b) das genannte Reservoir zum Aufnehmen von etwa 1 ml bis etwa 4 ml der genannten Flüssigkeit konfiguriert ist;

- (c) die genannte durchstechbare Membran (160) inert ist;
- (d) die genannte durchstechbare Membran (160) bei Temperaturen von etwa -80°C bis etwa 70°C intakt und durchstechbar bleibt; 5
- (e) die genannte durchstechbare Membran (160) mit Klebstoff, durch Heißsiegeln, mit einem Befestigungsmittel oder mit beliebigen Kombinationen davon dichtend an der genannten Dichtungsfläche angebracht wird; 10
- (f) das genannte Durchstechelement (6) von einer Innenfläche des genannten Trichters verläuft und optional schräg einwärts oder auswärts zu dem genannten ersten offenen Ende des genannten Trichters hin verläuft; 15
- (g) die genannte Seitenwand optional eine zweite Schneidkante aufweist;
- (h) der genannte Trichter (400) mehrere Durchstechelemente (6), optional zwei oder drei Durchstechelemente umfasst; 20
- (i) das genannte System Dichtungsmittel zum Abdichten der genannten Kammer gegen Auslaufen aus dem genannten Behältersystem umfasst, wobei das genannte Dichtungsmittel optional eine Dichtungswand um den Innenumfang des genannten Deckels umfasst, der dichtend in eine Oberfläche des genannten Trichters eingreift, wenn das System in der Durchstechposition ist; 25
- (j) die genannte Phiole (500) lösbar an dem genannten Trichter (500) angebracht und so bemessen ist, dass sie nach dem Lösen von dem genannten Trichter an einer Kappe angebracht werden kann; 30
- (k) die genannte Phiole zur Verwendung in Standardlaborausrüstung konfiguriert ist, optional Abmessungen hat, die Industriestandardabmessungen für eine Blutsammelröhre entsprechen, und vorzugsweise eine T501-Röhre ist; und/oder 35
- (l) die genannte Kammer zum Aufnehmen von etwa 1 ml bis etwa 16 ml bemessen ist.
5. Behältersystem nach einem der Ansprüche 1 - 4, wobei die genannte Flüssigkeit eine Zusammensetzung zum Stabilisieren und Rückgewinnen einer Nukleinsäure, optional DNA oder RNA, von einer biologischen Probe ist. 45
6. Behältersystem nach einem der Ansprüche 1 - 5, das zusätzlich ein festes oder halbfestes Material in der genannten Phiole umfasst, das separat von der Flüssigkeit in dem Reservoir des genannten Deckels gehalten wird, bis die genannte durchstechbare Membran durchbrochen wird. 50
7. Verfahren zum Kombinieren einer Flüssigkeit mit einer biologischen Probe, das Folgendes beinhaltet: 55
- (I)
- (a) Bereitstellen eines Behältersystems nach Anspruch 1 oder 2;
- (b) Geben der Probe in die Kammer in der Phiole; und
- (c) Schließen des genannten Behältersystems durch entfernbare Anbringen des genannten Deckels an der genannten Phiole; und
- (d) Durchstoßen der genannten Membran, um die genannte Flüssigkeit in die genannte Kammer zu lassen, durch Bewegen des genannten Deckels und der genannten Phiole in die genannte Durchstechposition; oder
- (II)
- (a) Bereitstellen eines Behältersystems nach Anspruch 3 oder 4;
- (b) Geben der Probe zu der Kammer in der Phiole durch den genannten Trichter; und
- (c) Schließen des genannten Behältersystems durch entfernbare Anbringen des genannten Deckels an dem genannten ersten offenen Ende des genannten Trichters; und
- (d) Durchstoßen der genannten Membran, um die genannte Flüssigkeit in die genannte Kammer zu lassen, durch Bewegen des genannten Systems in die genannte Durchstechposition.
8. Verfahren nach Anspruch 7, wobei die Flüssigkeit eine Nukleinsäure konservierende Flüssigkeit ist.
9. Verfahren nach Anspruch 7 oder 8, wobei die Probe eine biologische Probe ist.
10. Verfahren nach einem der Ansprüche 7-9 zum Archivieren der Probe.
11. Kit zum Sammeln und Speichern von Proben, der Folgendes umfasst:
- (a) ein Behältersystem nach einem der Ansprüche 1 bis 6; und
- (b) Anweisungen für dessen Gebrauch.

Revendications

1. Système de récipient pour stocker un liquide de manière à pouvoir être libéré, comprenant :
- (a) un flacon (1) comprenant une première extrémité ouverte pour recevoir un échantillon, une seconde extrémité comprenant une chambre de

stockage d'échantillon (2) et un élément de perçage (6), dans lequel ledit élément de perçage (6) comprend une paroi latérale et un premier bord de coupe (33) s'étendant depuis un premier coin pointu vers un second coin qui définit l'intersection entre ledit bord de coupe et ladite paroi latérale ; et

(b) un couvercle (100) configuré pour s'engager de manière amovible avec ledit flacon (1), ledit couvercle comprenant un réservoir pour contenir le liquide et une membrane pouvant être percée (160) scellant le liquide au sein dudit réservoir ;

dans lequel, lorsque ledit système est fermé par engagement amovible dudit flacon avec ledit couvercle, ledit flacon et ledit couvercle sont mobiles vers une position de perçage dans laquelle l'élément de perçage (6) interrompt la membrane pouvant être percée (160) pour permettre une communication fluide entre ledit réservoir (102) et ladite chambre, dans lequel la chambre (2) est scellée contre les fuites vers l'extérieur du système de récipient dans la position de perçage.

2. Système de récipient selon la revendication 1, dans lequel .

(a) ledit couvercle comprend une paroi définissant tout ou une portion du périmètre dudit réservoir (102), ladite paroi ayant une surface d'étanchéité pour relier en la rendant étanche ladite membrane pouvant être percée (160) ;

(b) ledit réservoir (102) est configuré pour retenir environ 1 ml à environ 4 ml dudit liquide ;

(c) ladite membrane pouvant être percée (160) est inerte ;

(d) ladite membrane pouvant être percée (160) reste intacte et peut être percée à des températures allant d'environ -80°C à environ 70°C ;

(e) ladite membrane pouvant être percée est reliée en étant rendue étanche à ladite surface d'étanchéité par un adhésif, un traitement de soudure à chaud, un dispositif de fixation ou toute combinaison de ceux-ci ;

(f) la largeur de ladite première extrémité est approximativement équivalente à la largeur de ladite seconde extrémité, ou ladite première extrémité est généralement plus large que ladite seconde extrémité ;

(g) ladite chambre (2) est configurée pour recevoir environ 1 ml à environ 16 ml, ou environ 1 ml à environ 4 ml, dudit échantillon ;

(h) ledit élément de perçage (6) s'étend depuis une surface de base de ladite chambre (2) et, en option, approximativement perpendiculairement depuis ladite base, ou à un angle vers l'intérieur ou vers l'extérieur vers ladite première

extrémité ouverte dudit flacon ;

(i) ladite paroi latérale inclut en outre un second bord de coupe ;

(j) ledit flacon comprend une pluralité d'éléments de perçage (6), en option, deux ou trois éléments de perçage ;

(k) ledit système comprend un moyen d'étanchéité pour sceller ladite chambre contre les fuites vers l'extérieur dudit système de récipient suite au mouvement dudit système de récipient vers ladite position de perçage, et ledit moyen d'étanchéité comprend en option une paroi d'étanchéité autour de la circonférence intérieure dudit couvercle qui engage en la rendant étanche une surface dudit flacon lorsque le système est dans ladite position de perçage ; et/ou

(l) ledit flacon (1) et ledit couvercle (100) sont dimensionnés pour le transport à la fois dans un état séparé et dans un état relié.

3. Système de récipient pour stocker un liquide de manière à pouvoir être libéré, comprenant :

(a) un flacon (500) comprenant une chambre pour retenir un échantillon ;

(b) un couvercle (100) comprenant un réservoir pour contenir le liquide et une membrane pouvant être percée scellant le liquide au sein dudit réservoir ; et

(c) un entonnoir (400) comprenant une première extrémité ouverte pour recevoir ledit échantillon, un élément de perçage et un canal s'étendant depuis ladite première extrémité ouverte vers une seconde extrémité ouverte et qui est en communication fluide avec ladite chambre, ledit entonnoir (400) pouvant être relié de manière amovible audit couvercle au niveau de ladite première extrémité ouverte et relié de manière amovible ou permanente audit flacon au niveau de ladite seconde extrémité, et dans lequel ledit élément de perçage (6) comprend une paroi latérale et un premier bord de coupe (33) s'étendant depuis un premier coin pointu vers un second coin qui définit l'intersection entre ledit bord de coupe et ladite paroi latérale (120) ;

dans lequel, lorsque ledit système est fermé par la liaison amovible dudit couvercle (100) audit entonnoir (400), ledit système est mobile vers une position de perçage dans laquelle l'élément de perçage interrompt la membrane pouvant être percée pour permettre une communication fluide entre ledit réservoir et ladite chambre, par le biais dudit canal, dans lequel la chambre est scellée contre les fuites vers l'extérieur du système de récipient dans la position de perçage.

4. Système de récipient selon la revendication 3, dans

lequel .

- (a) ledit couvercle comprend une paroi (120) définissant tout ou une portion du périmètre dudit réservoir et incluant une surface d'étanchéité pour relier en la rendant étanche ladite membrane pouvant être percée ; 5
- (b) ledit réservoir est configuré pour retenir environ 1 ml à environ 4 ml dudit liquide ;
- (c) ladite membrane pouvant être percée (160) est inerte ; 10
- (d) ladite membrane pouvant être percée (160) reste intacte et peut être percée à des températures allant d'environ -80°C à environ 70°C ;
- (e) ladite membrane pouvant être percée (160) est reliée en étant rendue étanche à ladite surface d'étanchéité par un adhésif, un traitement de soudure à chaud, un dispositif de fixation ou toute combinaison de ceux-ci ; 15
- (f) ledit élément de perçage (6) s'étend depuis une surface intérieure dudit entonnoir et, en option, est à un angle vers l'intérieur ou vers l'extérieur vers ladite première extrémité ouverte dudit entonnoir ; 20
- (g) ladite paroi latérale incluant en option un second bord de coupe ; 25
- (h) ledit entonnoir (400) comprend une pluralité d'éléments de perçage (6), en option deux ou trois éléments de perçage ;
- (i) ledit système comprend un moyen d'étanchéité pour sceller ladite chambre contre les fuites vers l'extérieur dudit système de récipient, dans lequel ledit moyen d'étanchéité comprend en option une paroi d'étanchéité autour de la circonférence intérieure dudit couvercle qui engage en la rendant étanche une surface dudit entonnoir lorsque le système est dans la position de perçage ; 30
- (j) ledit flacon (500) est relié de manière amovible audit entonnoir (400) et dimensionné pour la liaison à un capuchon lors de la libération dudit entonnoir ; 35
- (k) ledit flacon est configuré pour une utilisation dans un équipement de laboratoire standard, possède en option des dimensions qui se conforment aux dimensions standard de l'industrie pour un tube de prélèvement sanguin, et de préférence est un tube T501 ; et/ou 40
- (l) ladite chambre est dimensionnée pour contenir environ 1 ml à environ 16 ml. 45
5. Système de récipient selon l'une quelconque des revendications 1 à 4, dans lequel ledit liquide est une composition pour la stabilisation et la récupération d'un acide nucléique, en option de l'ADN ou de l'ARN, à partir d'un échantillon biologique. 55
6. Système de récipient selon l'une quelconque des revendications 1 à 5, comprenant en outre un matériau solide ou semi-solide au sein dudit flacon et maintenu séparé du liquide dans le réservoir dudit couvercle jusqu'à ce que ladite membrane pouvant être percée soit interrompue.
7. Procédé de combinaison d'un liquide avec un échantillon biologique, comprenant :
- (I)
- (a) la fourniture d'un système de récipient selon la revendication 1 ou 2 ;
- (b) la fourniture de l'échantillon à la chambre dans le flacon ; et
- (c) la fermeture dudit système de récipient en reliant de manière amovible ledit couvercle audit flacon ; et
- (d) le perçage de ladite membrane pour libérer ledit liquide dans ladite chambre en déplaçant ledit couvercle et ledit flacon vers ladite position de perçage ; ou
- (II)
- (a) la fourniture d'un système de récipient selon la revendication 3 ou 4 ;
- (b) la fourniture de l'échantillon à la chambre dans le flacon à travers ledit entonnoir ; et
- (c) la fermeture dudit système de récipient en reliant de manière amovible ledit couvercle à ladite première extrémité ouverte dudit entonnoir ; et
- (d) le perçage de ladite membrane pour libérer ledit liquide dans ladite chambre en déplaçant ledit système vers ladite position de perçage.
8. Procédé selon la revendication 7, dans lequel le liquide est un liquide préservant l'acide nucléique.
9. Procédé selon la revendication 7 ou 8, dans lequel l'échantillon est un échantillon biologique.
10. Procédé selon l'une quelconque des revendications 7 à 9 pour l'archivage de l'échantillon.
11. Kit de recueil et de stockage d'échantillon, comprenant :
- (a) un système de récipient selon l'une quelconque des revendications 1 à 6 ; et
- (b) des instructions pour l'utilisation de celui-ci.

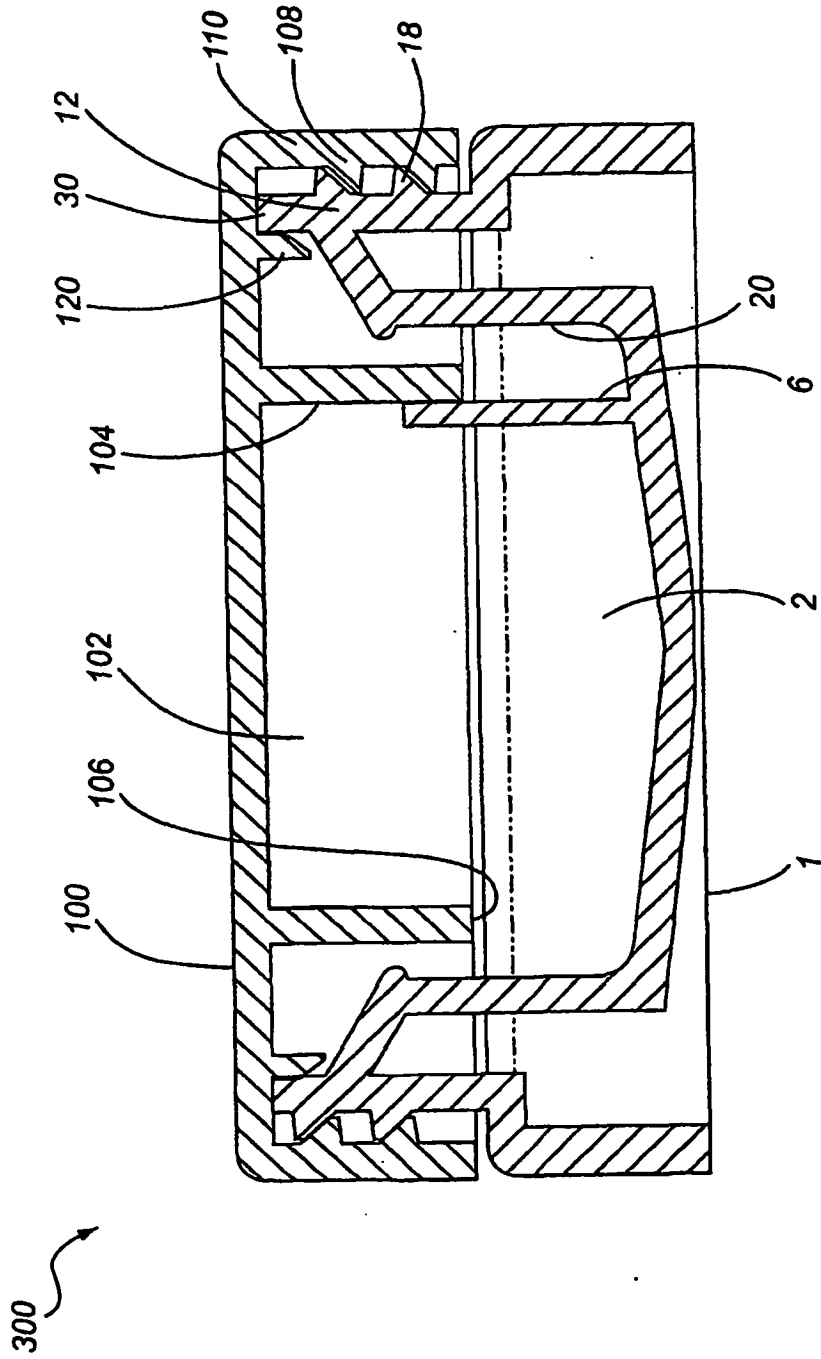

FIG. 1

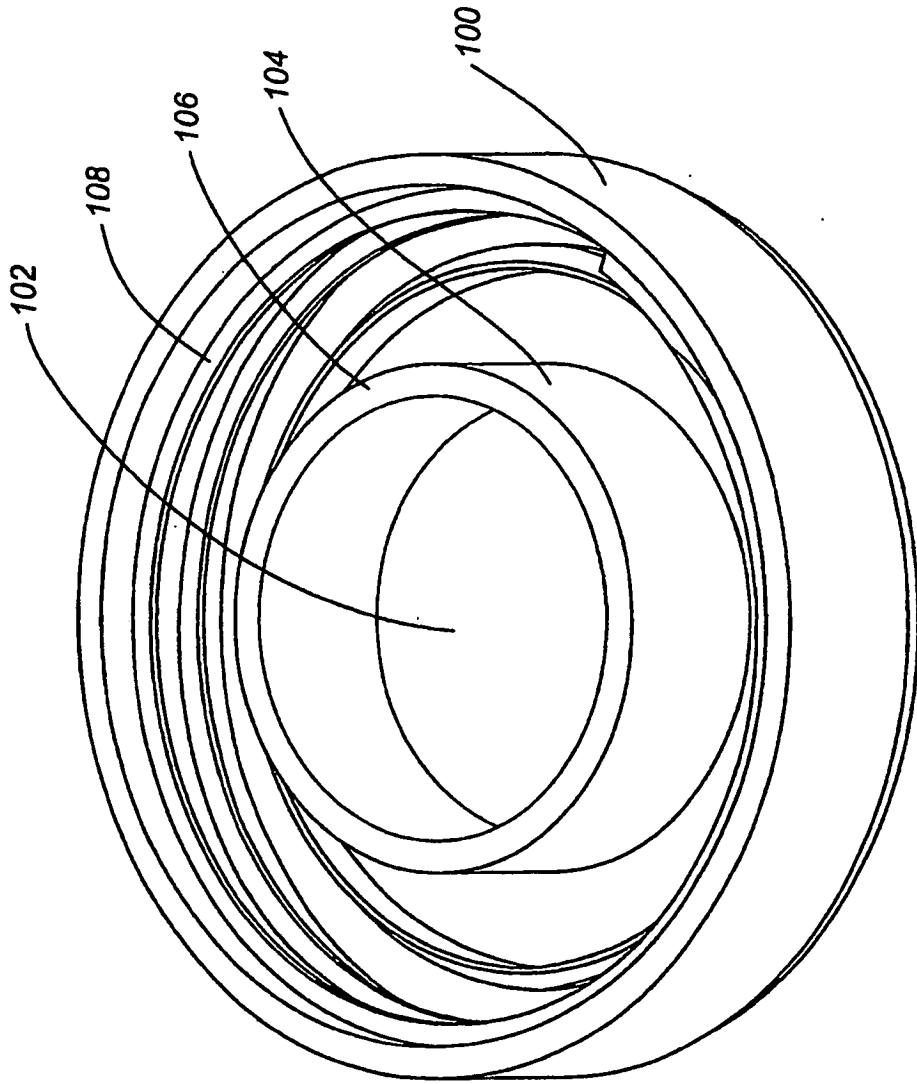

FIG. 2

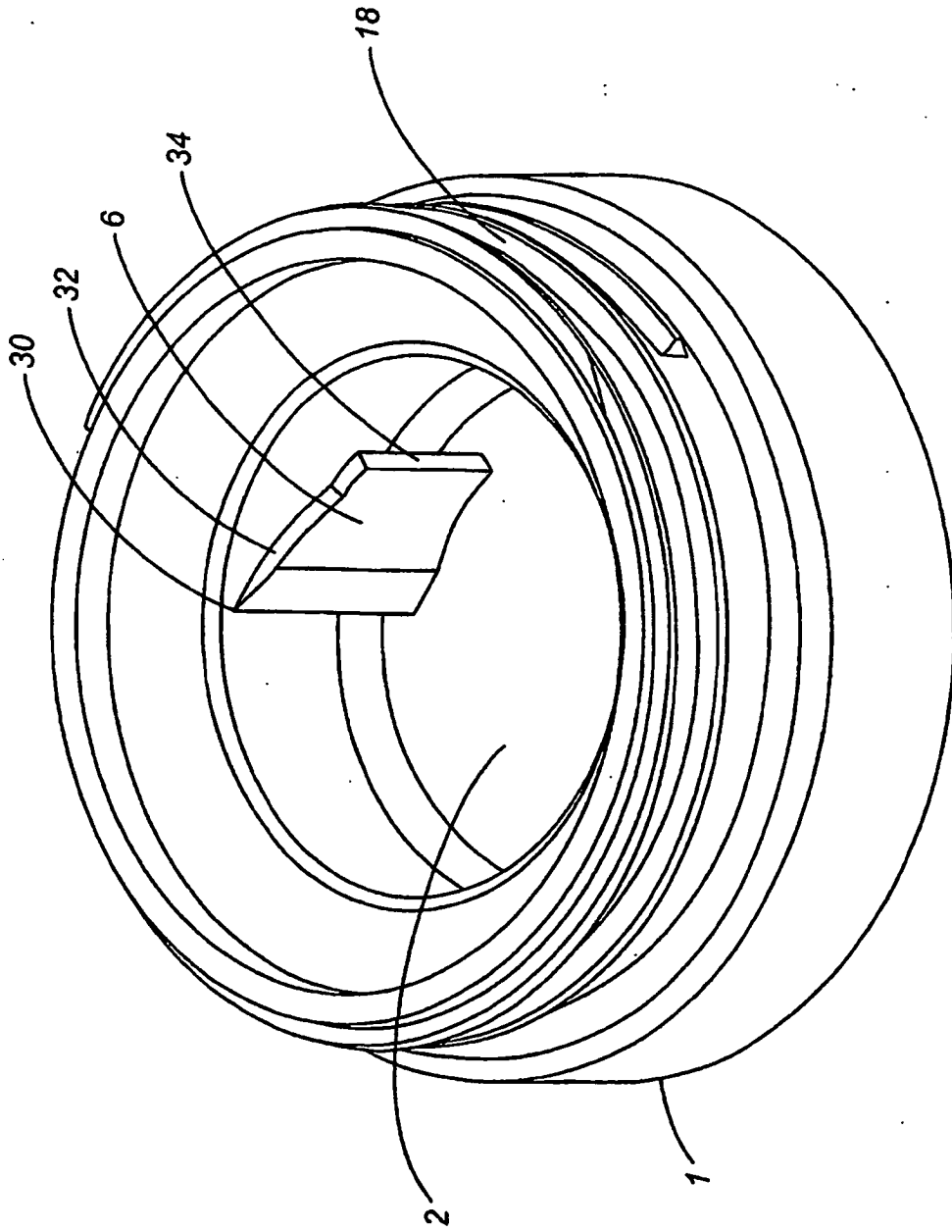

FIG. 3

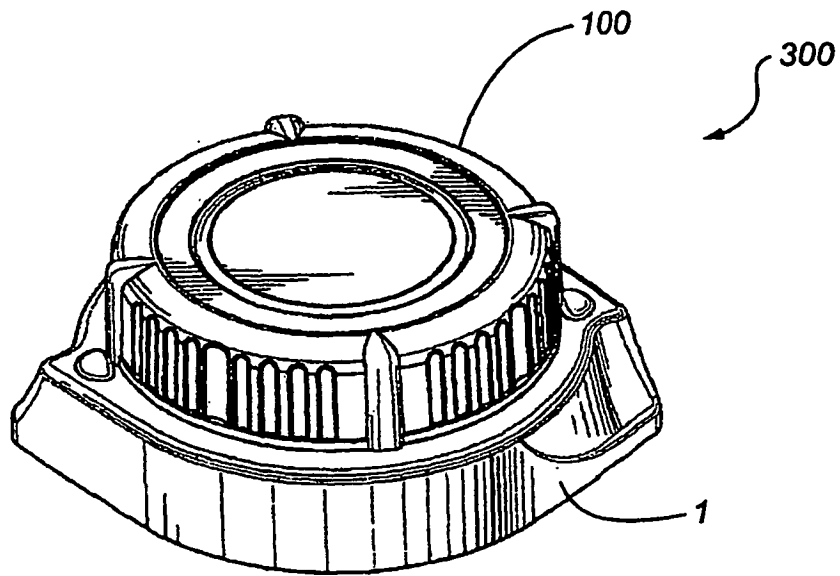

FIG. 4

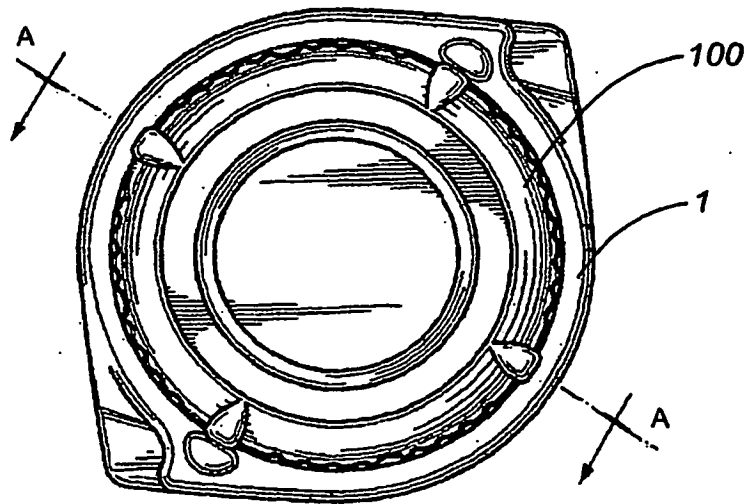

FIG. 5

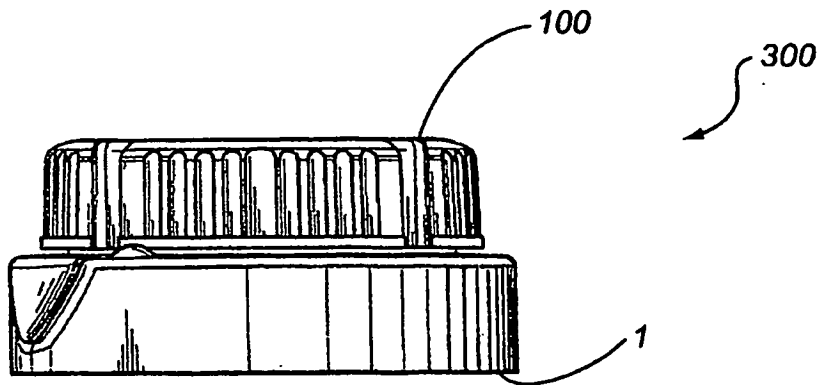

FIG. 6

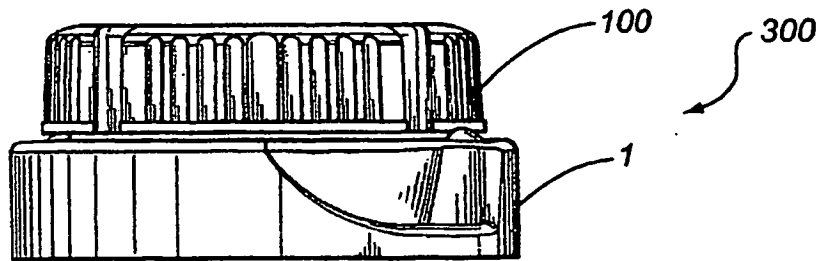

FIG. 7

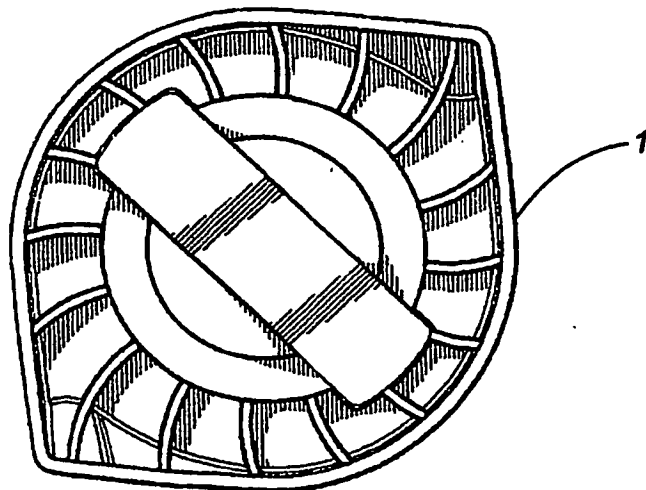

FIG. 8

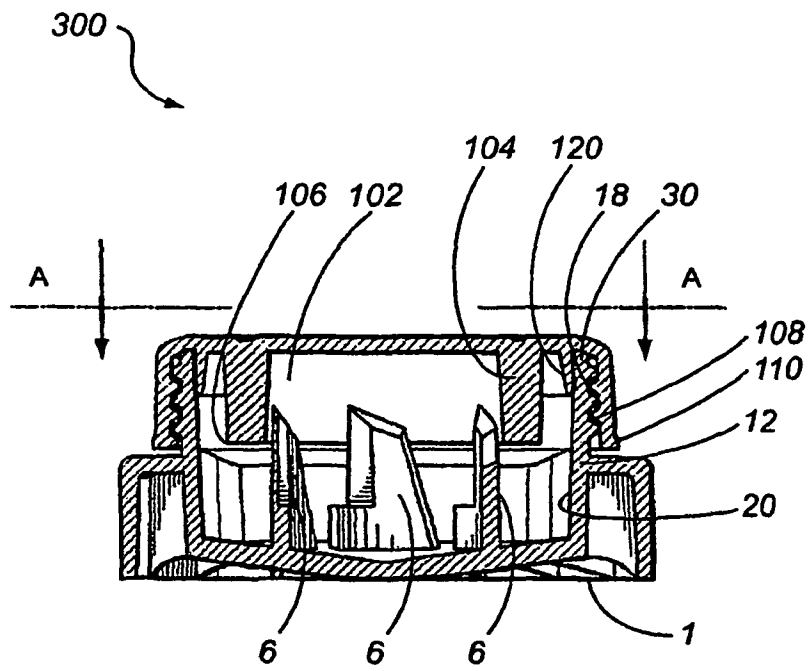

FIG. 9

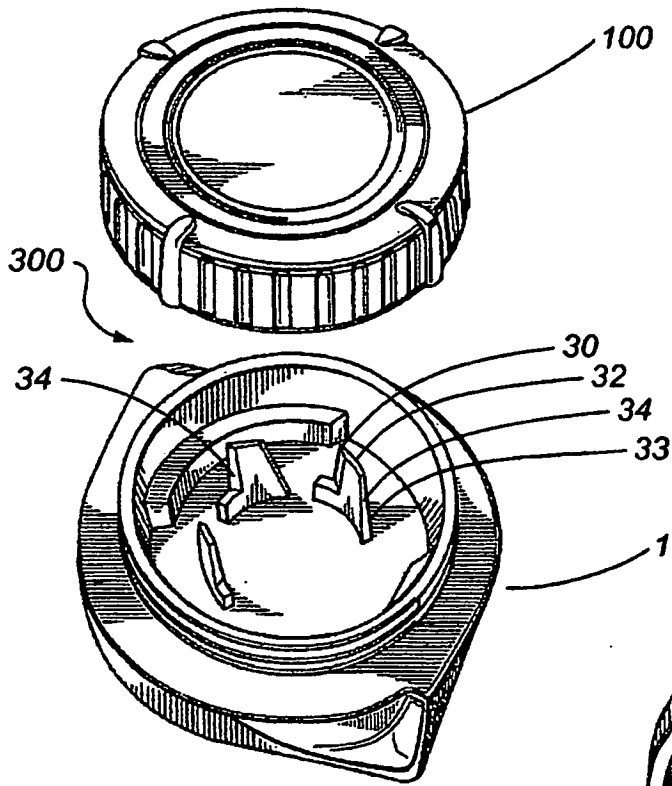

FIG. 10

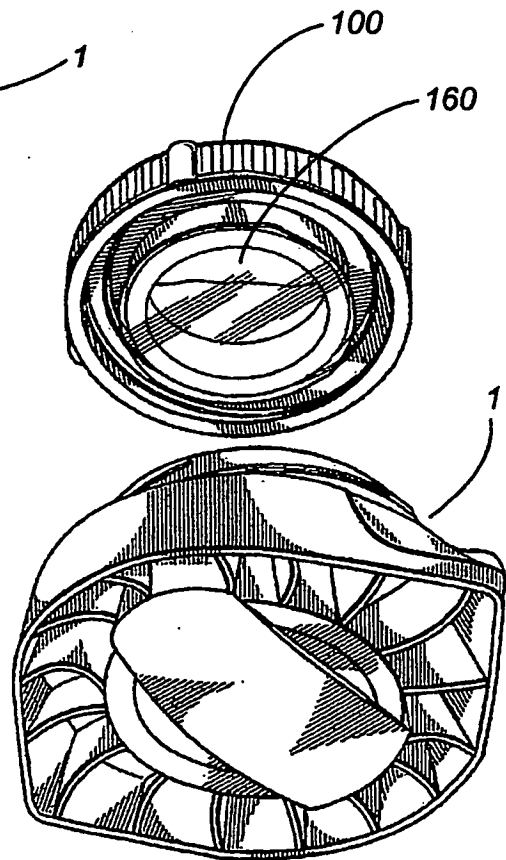

FIG. 11

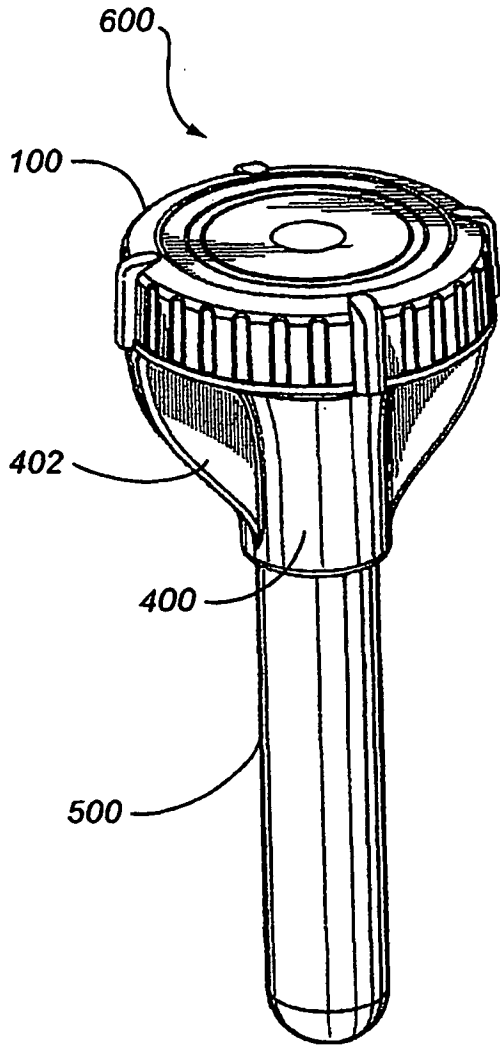

FIG. 12

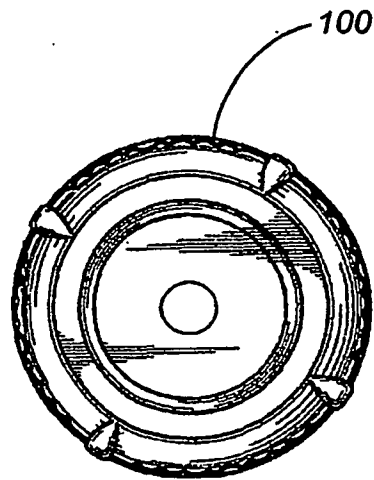

FIG. 13

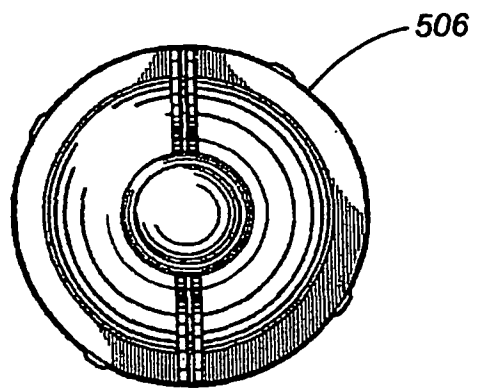

FIG. 14

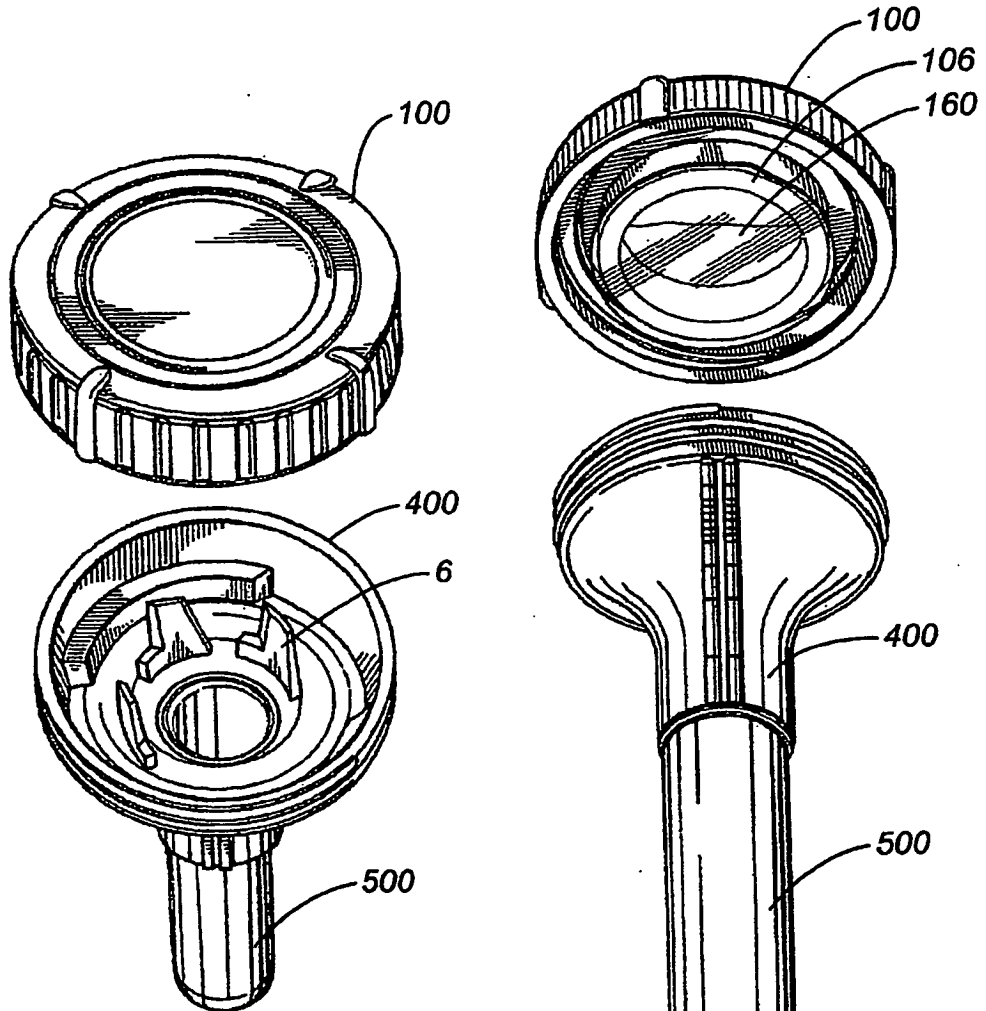

FIG. 18

FIG. 19

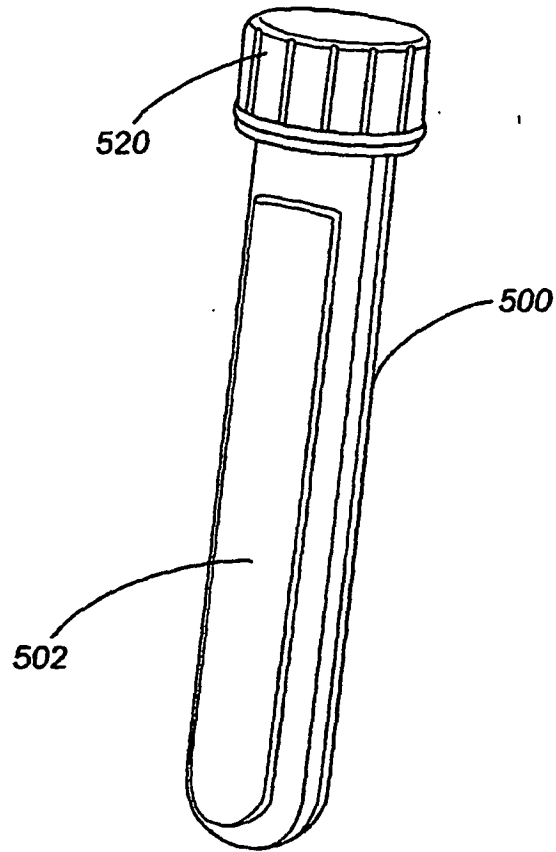

FIG. 20

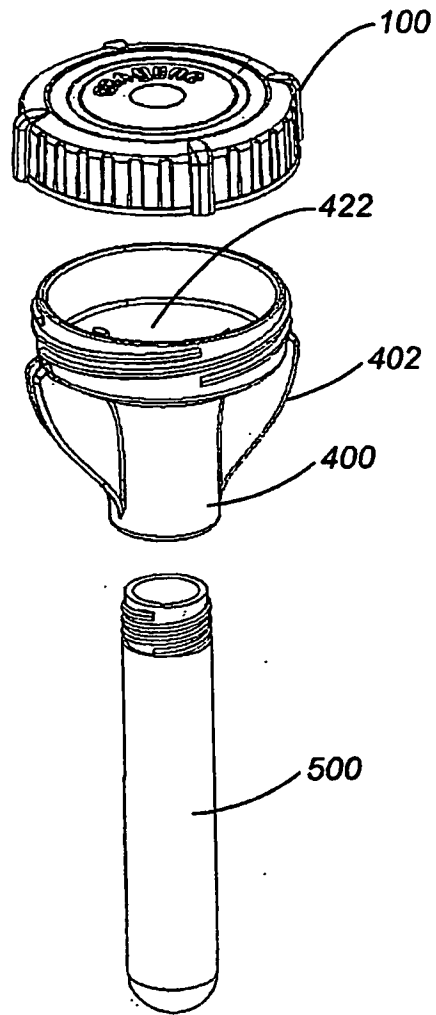

FIG. 21

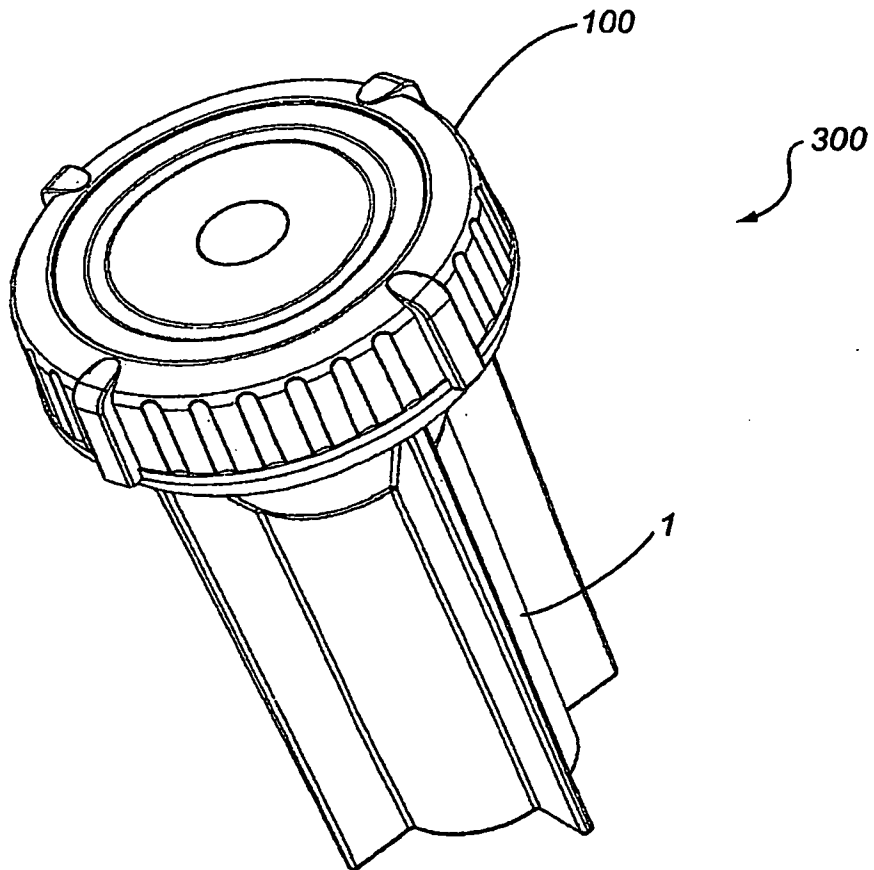

FIG. 22

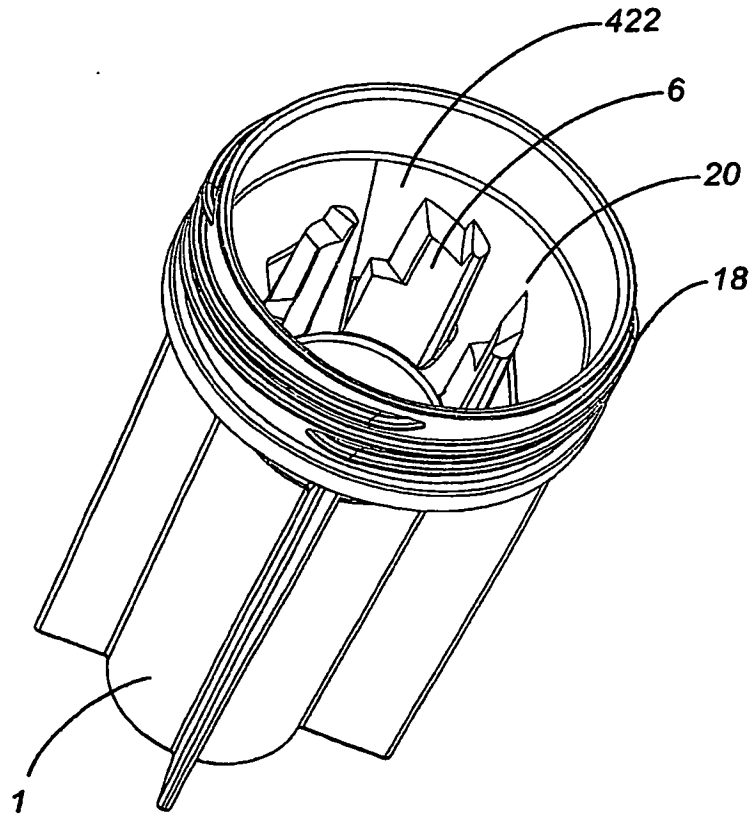

FIG. 23

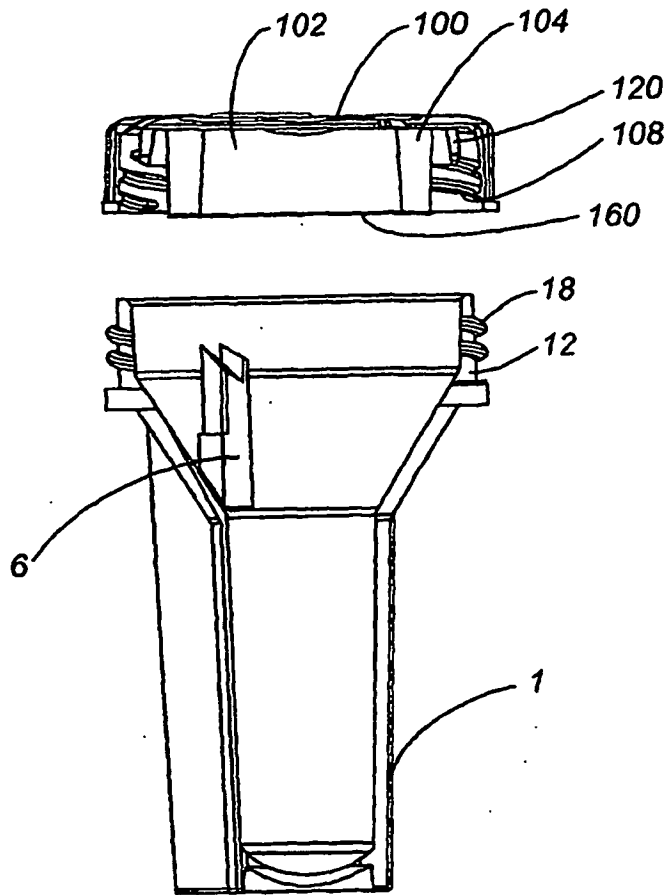

FIG. 24

REFERENCES CITED IN THE DESCRIPTION

This list of references cited by the applicant is for the reader's convenience only. It does not form part of the European patent document. Even though great care has been taken in compiling the references, errors or omissions cannot be excluded and the EPO disclaims all liability in this regard.

Patent documents cited in the description

- US 60748977 B [0001]
- US 6138821 A [0009]
- WO 2003104251 A [0010] [0079]
- CA 2006000380 W [0079]
- US 60828563 B [0079]
- US 60866985 B [0079]

专利名称(译)	用于可释放地储存物质的容器系统		
公开(公告)号	EP1956969A4	公开(公告)日	2010-06-09
申请号	EP2006846923	申请日	2006-12-11
[标]申请(专利权)人(译)	DNA基因科技公司		
申请(专利权)人(译)	DNA GENOTEK INC.		
当前申请(专利权)人(译)	DNA GENOTEK INC.		
[标]发明人	MUIR ROD KIRKLAND DEREK CURRY IAN SUNSTRUM ROY LEM PAUL BIRNBOIM H CHAIM		
发明人	MUIR, ROD KIRKLAND, DEREK CURRY, IAN SUNSTRUM, ROY LEM, PAUL BIRNBOIM, H. CHAIM		
IPC分类号	A61B5/00 A61B5/15 A61J1/05 B01L3/14 B65D47/36 B65D81/32		
CPC分类号	A61B10/0051 A61B10/0096 B01L3/502 B01L3/50825 B01L2300/042 B01L2300/044 B01L2300/047 B01L2300/0672 B65D51/2835 G01N21/03 G01N35/1079 G01N2021/0328 Y10T137/0318 B65D1/09		
代理机构(译)	TIMOTHY JOHN SIMON , 跳		
优先权	60/748977 2005-12-09 US		
其他公开文献	EP1956969B1 EP1956969A1		
外部链接	Espacenet		

摘要(译)

本发明提供一种用于可释放地储存物质的容器系统。容器系统包括具有样品储存室和用于刺穿盖子中的膜的刺穿构件的小瓶，该膜密封盖子中的贮存器内的物质，直到薄膜被刺穿构件刺穿。容器系统可选地包括漏斗。还提供了一种用于这种容器系统的方法和套件。