

(19) World Intellectual Property Organization
International Bureau



(43) International Publication Date
12 September 2002 (12.09.2002)

PCT

(10) International Publication Number
WO 02/069791 A1

- (51) International Patent Classification⁷: **A61B 5/00**, 5/05, G01N 33/487, 22/00
- (52) International Application Number: PCT/IB01/00334
- (53) International Filing Date: 6 March 2001 (06.03.2001)
- (54) Filing Language: English
- (55) Publication Language: English
- (71) Applicant (for all designated States except US): **PEN-DRAGON MEDICAL LTD.** [CH/CH]; Hagenholzstrasse 81a, CH-8050 Zürich (CH).
- (72) Inventors; and
- (73) Inventors/Applicants (for US only): **SCHREPFER, Thomas, W.** [CH/CH]; Rumermatt 184, CH-5225 Oberbözberg (CH). **CADUFF, Andreas** [CH/CH]; Klingenstrasse 21, CH-8005 Zürich (CH). **HIRT, Etienne** [CH/CH]; Röhrliberg 50, CH-6330 Cham (CH).
- (74) Agent: **E. BLUM & CO.**; Vorderberg 11, CH-8044 Zürich (CH).
- (81) Designated States (national): AE, AG, AL, AM, AT, AU, AZ, BA, BB, BG, BR, BY, BZ, CA, CH, CN, CR, CU, CZ, DE, DK, DM, DZ, EE, ES, FI, GB, GD, GE, GH, GM, HR, HU, ID, IL, IN, IS, JP, KE, KG, KP, KR, KZ, LC, LK, LR, LS, LT, LU, LV, MA, MD, MG, MK, MN, MW, MX, MZ, NO, NZ, PL, PT, RO, RU, SD, SE, SG, SI, SK, SL, TJ, TM, TR, TT, TZ, UA, UG, US, UZ, VN, YU, ZA, ZW.
- (84) Designated States (regional): ARIPO patent (GH, GM, KE, LS, MW, MZ, SD, SL, SZ, TZ, UG, ZW), Eurasian patent (AM, AZ, BY, KG, KZ, MD, RU, TJ, TM), European patent (AT, BE, CH, CY, DE, DK, ES, FI, FR, GB, GR, IE, IT, LU, MC, NL, PT, SE, TR), OAPI patent (BF, BJ, CF, CG, CI, CM, GA, GN, GW, ML, MR, NE, SN, TD, TG).

[Continued on next page]

(54) Title: METHOD AND DEVICE FOR DETERMINING THE CONCENTRATION OF A SUBSTANCE IN BODY LIQUID

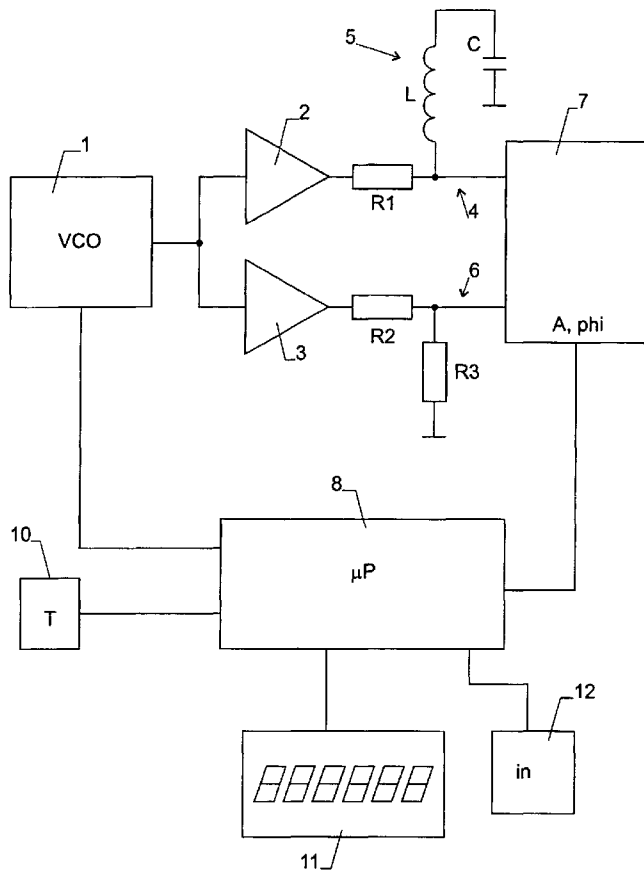

(57) Abstract: For measuring the concentration of a substance in body fluid, such as the glucose level in blood or tissue, a strip electrode (18) and a ring electrode (19) are arranged at the specimen. The ring electrode (19) is in direct electrical contact with the specimen while the strip electrode (18) is electrically insulated therefrom. The strip electrode (18) is arranged parallel to an arm or a leg for obtaining a large interaction length. The electrodes (18, 19) form a capacitor in a resonant circuit. A modulated voltage in the MHz range close to or at the resonance frequency is applied to the electrodes and the response of the body fluid is measured. This design allows a measurement of high accuracy.

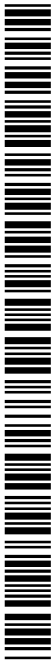

WO 02/069791 A1



Published:

— with international search report

For two-letter codes and other abbreviations, refer to the "Guidance Notes on Codes and Abbreviations" appearing at the beginning of each regular issue of the PCT Gazette.

Method and device for determining the concentration of a
substance in body liquid

5 Technical Field

The invention relates to a method and a device for determining the concentration of a substance in an in-vitro or in-vivo specimen containing body liquid
10 according to the preamble of the independent claims.

Background Art

Radio wave spectroscopy has been known to
15 provide promising potential in the in-vitro and in-vivo determination of the concentration of glucose and other substances in body fluids. In particular, this technology is of substantial interest for the determination of glucose concentration in blood and/or inter- or intracellular liquid. A device for measuring blood level glucose is
20 disclosed in US 5 792 668, where two electrodes are brought into direct contact with the human body and the impedance is measured between them.

Despite its potential, the technology has not
25 yet been used in commercial devices, which is attributed to the limited accuracy of the presently known solutions.

Disclosure of the Invention

30 Hence, it is the goal of the invention to provide a method and device that allow to increase the reliability of this type of measurement.

This goal is reached by the independent
35 claims.

In a first aspect of the invention, the first electrode is electrically insulated from the specimen.

Hence, the measured parameter does not depend on the surface conditions of the specimen. Rather, the signal is capacitively coupled to the specimen and the measured parameter depends therefore primarily on the conditions
5 within the specimen. The parameter measured in this way can then be converted to the desired concentration, e.g. by using calibration data.

Preferably, at least two electrodes are provided, wherein the modulated voltage is applied between
10 them. By using two electrodes, a defined field can be established within the specimen. For best signals, it has been found advantageous to place the second electrode in electric contact with the specimen.

The measured parameter preferably depends on
15 the electrical impedance at the electrode(s). It has been found that the concentration of various substances, in particular glucose, affects the real or imaginary part of this impedance because it changes the loss and/or dielectric constant of body fluid.

Preferably, the electrode forms part of a
20 resonant circuit, which is operated at or close to its resonance frequency. Under such conditions, a change of the dielectric or loss properties of the specimen leads to substantial shifts in the parameters of the resonant
25 circuit and can therefore be measured with high sensitivity.

A further aspect of the invention is directed to a device particularly suited for in-vivo measurements of the human body. This device comprises an elongate
30 electrode having a width much smaller than its length. A holder is provided to mount the electrode to an arm or a leg with the longitudinal axis of the electrode extending parallel thereto. In this way, a large interaction space is established, which allows to measure the desired con-
35 centration with a higher level of accuracy.

The method and device of the present invention has been found to be especially suited for measuring the glucose concentration in body fluid.

5

Brief Description of the Drawings

The invention will be better understood and objects other than those set forth above will become apparent when consideration is given to the following detailed description thereof. Such description makes reference to the annexed drawings, wherein:

Fig. 1 is a block circuit diagram of a preferred device for carrying out the invention,

15 Fig. 2 is a view onto a possible embodiment of the device,

Fig. 3 is a section along line III-III of Fig. 2,

20 Fig. 4 is the device of Fig. 3 with a wristband,

Fig. 5 shows the behavior of the relative amplitude A as a function of frequency,

Fig. 6 is a second embodiment of the circuit,

Fig. 7 is an alternative electrode geometry,

25 Fig. 8 shows measurements at varying glucose concentrations (mmol/liter) in physiologic solution and

Fig. 9 a third embodiment of the circuit.

30

Modes for Carrying Out the Invention

Fig. 1 shows a block circuit diagram of a preferred device for carrying out the invention. It comprises a voltage controlled oscillator (VCO) 1 as a signal source for generating a sine wave signal. This signal is fed to two amplifiers 2, 3. The output of first amplifier 2 is connected via a resistor R1 to a first signal

35

path 4. A resonant circuit 5 comprising an inductance L and a capacitor C in series is connected between first signal path 4 and ground. The output of second amplifier 3 is connected via a resistor R2 to a second signal path 6. Second signal path 6 is substantially identical to first signal path 4 but comprises a resistor R3 as a reference load instead of resonant circuit 5.

Both signal paths 4, 6 are fed to a measuring circuit 7, which determines the relative amplitude A of both signals as well as, optionally, their mutual phase shift ϕ . Relative amplitude A can e.g. be the amplitude of first signal path 4 in units of the amplitude of second signal path 6 (wherein the amplitudes are the peak values of the sine waves).

The output signal of measuring circuit 7 is fed to a microprocessor 8, which also controls the operation of VCO 1.

As can be seen from Fig. 1, the device in the present embodiment further comprises a temperature sensor 10, a display 11 and an input device 12 with user operable controls, all of which are controlled by microprocessor 8.

Inductance L of the device of Fig. 1 can be generated by a coil and/or by the leads and electrodes of capacitor C. Its value is generally known with reasonable accuracy.

Capacitor C of the device of Fig. 1 is used as an antenna for probing a specimen. For this purpose, it is formed by electrodes that are arranged near the specimen. The geometry of the electrodes is selected such that the electric field generated by them extends into the specimen and the body liquid to be measured. Suitable geometries are discussed below. As mentioned above, at least one of the electrodes of the capacitor is electrically isolated such that capacitor C is primarily a capacitive load, the capacitance and loss of which depends

on the electrical properties (i.e. the response) of the specimen at the frequency of VCO 1.

To measure the concentration of a substance in the body fluid of the specimen, microprocessor 8 can e.g. initiate a measurement cycle consisting of a frequency sweep of VCO 1. The sweep should start at a frequency f_{min} below the expected resonance frequency f_0 of the resonant circuit 5 and extend to a frequency f_{max} above resonance frequency f . During this sweep, the electrical properties of signal path 4 will change substantially, while those of signal path 6 will vary only slightly. The amplitude determined by measuring circuit A will therefore fall to a minimum A_0 at f_0 , as shown in Fig. 5. At the same time, phase shift ϕ crosses zero.

As can be shown, the dependence of A_0 on the dielectric constant $\epsilon(f)$ and, in particular, on the loss or conductance $\rho(f)$ of the fluid in the specimen is stronger than at off-resonance frequencies, which allows a sensitive measurement of the liquid's response to the electric field.

This is shown in Fig. 8, which represents measurements of the type shown in Fig. 5 at glucose concentrations between 0 and 17.5 mmol/l. The vertical axis represents the ratio in dB of the signals from first signal path 4 and second signal path 6. The resonance frequency is around 35.5 MHz.

It is presently believed that the specific impedance of the body fluid, i.e. the specific conductivity $\rho(f)$ and the dielectric constant $\epsilon(f)$ in a frequency range between 10 MHz and 2000 MHz, and in particular between 20 MHz and 70 MHz, are a function of the properties and concentration of the salty (ionic) components of the human body. These salty components primarily include solvated sodium, potassium, calcium and other minor ions and their counter ions, the primary counter ion being chloride. Other non-ionic solvated substances, in particular substances having a similar range of size as the ion com-

plexes, can have an impact on the impedance pattern of the salty body fluid components, provided these substances occur in sufficient concentration. In particular, glucose has a similar range of size and is present in concentrations giving rise to a well detectable variation of the amplitude A0 at resonance frequency.

In a simple embodiment, only amplitude A0 is measured as a parameter for the determination of the concentration. Suitable calibration data stored in micro-processor 8 is used to convert amplitude A0 into the desired concentration level.

The effects exploited for the measurement are temperature dependent. In order to obtain high accuracy over a wide temperature range, temperature sensor 10 is brought into thermal contact with the specimen to be measured. The signals from temperature sensor 10 are used to correct the obtained result, again using calibration data obtain from calibration measurements.

A proper design of the electrodes of capacitor C allows to optimize the accuracy and sensitivity of the present device in a given application. A preferred geometry of the device for in-vivo measurements in a living body is shown in Figs. 2 and 3.

The device comprises a housing 13 closed on one side by an electrode plate 14. The display 11 is arranged opposite electrode plate 14. The electronic circuits 16 are arranged between electrode plate 14 and display 11.

Electrode plate 14 comprises an electrically insulating substrate 17 with a strip electrode 18 and a top or ring electrode 19 arranged on an outer side thereof. An inner side 21 of insulating substrate 17 is covered by a bottom electrode 22. A plurality of through-contacts 23 are provided to connect ring electrode 19 to bottom electrode 22. A further through-contact 24 connects one end of strip electrode 18 to a small bond pad

25 arranged in an opening 26 of bottom electrode 22 on inner side 21.

Temperature sensor 10 is mounted to bottom electrode 22. The large number of through-contacts 23 ensure that bottom electrode 22 follows the temperature of ring electrode 18 and therefore the temperature of the specimen closely.

A typical size of electrode plate 14 is 32 mm x 21 mm. Bottom electrode 22 covers all of inner side 21 except for the small opening 26 and is therefore much larger than strip electrode 18.

Leads 28 are provided to connect bottom electrode 22, contact pad 26 and temperature sensor 10 to the electronic circuits 16.

While bottom electrode 22 and ring electrode 19 are connected to ground, strip electrode 18 is connected to inductance L of resonant circuit 5. Therefore, the capacitor C is formed between strip electrode 18 as a first electrode and ring electrode 19 and bottom electrode 22 as a second electrode. In other words, the second electrode consists of two electrode layers: a top electrode layer formed by ring electrode 19 and a bottom electrode layer formed by bottom electrode 22.

An electrically insulating cover layer 29 covers all of strip electrode 18 but not ring electrode 19. In other words, strip electrode 18 is arranged between substrate 17 and cover layer 29. Cover layer 29 is preferably of a hard, moisture- and salt-impervious material such as glass, ceramics, a polycarbonate or diamond-like carbon (DLC) of a thickness preferably between 50 and 100 μm .

As can be seen in Fig. 4, a holder or wrist-band 31 is attached to housing 13 for fixing the device to an arm or a leg of a human body with cover layer 29 facing the body and a longitudinal axis of strip electrode 18 parallel to the arm or leg. In this way, ring electrode 19 comes into contact with the user's skin and

sets the same to ground reference potential. The electric field generated by strip electrode 18 extends into the body tissue. Since strip electrode 18 is elongate and has a width much smaller than its length and extends along the arm or leg, a comparatively large region of the body is reached by the field. This allows to obtain more sensitive and accurate measurements.

As described above, a pure sine voltage has been found to be sufficient for obtaining accurate measurements. However, other types for modulated voltages, such as square-wave voltages or pulses can be used as well. In this case, measuring circuit 7 is preferably provided with suitable filters for selectively sampling one or more frequency components. At least one measured frequency component is preferably close to the resonance frequency of resonant circuit 5 for exploiting the circuit's high sensitivity to the specimen's properties at that frequency.

The electrode geometry can be varied for adapting it to a given application. While the design of Fig. 2 is optimized for a measurement on an arm or leg, a circular design can be used for measurement on a flatter body part or an in-vitro sample.

Ring electrode 19 does not necessarily have to form a closed ring as long as it provides sufficient grounding of the body part to be measured. It can e.g. also have U-shape or consist of two stripes parallel to and laterally enclosing strip electrode 18. Ring electrode 19 can also be omitted completely or be covered by cover layer 29, in particular for in-vitro measurements where noise is low.

Part of a further embodiment of the circuit is shown in Fig. 6. Here, no direct connection between resonant circuit 5 and measuring circuit 7 is used. Rather, an antenna electrode 33 is located in proximity to the electrodes of capacitor C, and measuring circuit 7 measures the signal returned by antenna electrode 33.

A possible arrangement of the electrodes is shown in Fig. 7. As can be seen, antenna electrode 33 is strip shaped and arranged in parallel to strip electrode 18. Both, antenna electrode 33 and strip electrode 18 are covered by cover layer 29 and therefore electrically insulated from the specimen.

The device of Figs. 6 and 7 is again sweeping VCO 1 between a frequency f_{min} below the resonance frequency f_0 of resonant circuit 5 and a frequency f_{max} above it. In contrast to Fig. 5, measuring circuit 7 now detects a maximum amplitude A_0 at f_0 , wherein the value of A_0 depends on the response, i.e. the electrical properties of the specimen at the resonance frequency f_0 . The parameter A_0 can now again be processed using calibration data as described above.

A comparison of the device of Figs. 1 and 2 with the device of Figs. 6 and 7 shows that the first embodiment measures the response of the specimen from the signal reflected to strip electrode 18. The second embodiment measures the response of the specimen from the signal transmitted from strip electrode 18 to antenna electrode 33.

It is found that the transmission and reflection show different dependencies on the concentrations of various compounds of the body fluid. Hence, a combined measurement of reflection and transmission allows a further refinement of the measurement by elimination of the influence of compounds not of interest for the quantity to be measured.

A third embodiment of a circuit is shown in Fig. 9. Here, the capacitor C formed by the electrodes is part of the resonant tank circuit of an active, self-oscillating oscillator 40. The amplitude A and frequency f_0 of the output signal of oscillator 40 depend on the capacitance and losses in capacitor C . The corresponding signal is fed to measuring circuit 7, which evaluates the parameters A and f_0 . Measuring the corresponding parame-

ters A and f0 again allows a sensitive measurement of the desired concentration using calibration data.

In the examples shown so far, the invention was used in a device for qualitatively or quantitatively displaying the concentration a substance (such as glucose) in body liquid. The invention can, however, e.g. also be used in devices that automatically administer medication to a body, such as an insulin pump, where the amount and/or time for administering the medication depends on the measured concentration. It can also be used in any other type of device that requires the measurement of the concentration of a substance in body fluid.

While there are shown and described presently preferred embodiments of the invention, it is to be distinctly understood that the invention is not limited thereto but may be otherwise variously embodied and practiced within the scope of the following claims.

Claims

1. A method for determining the concentration of a substance in a in-vitro or in-vivo specimen containing body liquid comprising the steps of

arranging a first electrode (18) at said specimen, wherein said first electrode is electrically insulated from the specimen,

applying a modulated electrical voltage to the first electrode for generating a modulated field in the specimen and

measuring at least one parameter (A, phi) depending on a response of the specimen to the field and determining the concentration therefrom.

2. The method of claim 1 comprising the step of arranging a second electrode (19, 22) at said specimen, wherein the modulated electrical voltage is applied between the first and the second electrode (19, 22).

3. The method of claim 2 wherein the second electrode (19, 22) is in electric contact with the body liquid in the specimen.

4. The method of one of the preceding claims further comprising the step of measuring a temperature (T) of the specimen and using the temperature in the determination of the concentration.

5. The method of one of the preceding claims wherein the modulated electrical voltage is a sine voltage.

6. The method of one of the preceding claims wherein the modulated electrical voltage has a frequency between 10 MHz and 2 GHz, in particular between 20 MHz and 70 MHz.

7. The method of one of the preceding claims wherein the parameter (A, phi, f0) depends on the electrical impedance at the first electrode.

8. The method of one of the preceding claims wherein the response of the specimen is measured by measuring a signal reflected from the first electrode.

9. The method of one of the preceding claims
5 wherein an antenna electrode (33) is arranged at the specimen in proximity to the first electrode (18) and wherein the response of the specimen is measured by measuring a signal transmitted from the first electrode (18) to the antenna electrode (33).

10 10. The method of one of the preceding claims wherein the substance is glucose.

11. The method of one of the preceding claims wherein the specimen is a living body.

12. The method of one of the preceding claims
15 comprising the step of using calibration data to convert the parameter (A, ϕ , f_0) to the concentration.

13. The method of one of the preceding claims wherein the first electrode forms part of a resonant circuit (5) having a resonance frequency (f_0) and wherein
20 the resonant circuit (5) is operated substantially at the resonance frequency.

14. The method of claim 13 wherein the resonant circuit is at least part of a tank circuit of an active oscillator (40) and wherein the parameter is an amplitude (A) and/or a frequency (f_0) of a signal generated
25 by said oscillator (40).

15. The method of claim 13 wherein the modulated voltage is frequency swept from a frequency (f_{\min}) below the resonance frequency (f_0) to a frequency
30 (f_{\max}) above the resonance frequency, and in particular wherein the parameter is a signal reflected to the first electrode (18) or transmitted to an antenna electrode (33) at the resonance frequency (f_0).

16. A device for determining the concentration
35 of a substance in a in-vitro or in-vivo specimen containing body liquid, in particular for carrying out the method of one of the preceding claims, comprising

a first electrode (18) covered by a cover layer (29) of insulating material,

a signal source (1) connected to the first electrode (18) applying a modulated electrical voltage to the first electrode (18) for generating an electric field in the specimen,

a measuring circuit (7) for measuring at least one parameter depending on a response of the specimen to the field, and

a data processor (8) determining the concentration from the parameter.

17. The device of claim 16 comprising a holder (31) for fixing the first electrode (18) to a part of a body with the cover layer (29) facing the body.

18. The device of one of the claims 16 or 17 further comprising an electrically insulating substrate (17), wherein the first electrode (18) is arranged on a first side (20) of the substrate (17) between the substrate (17) and the cover layer (29).

19. The device of claim 18 further comprising a second electrode (19, 22) arranged on the substrate, wherein the signal source (2) is connected to apply the modulated electrical voltage between the first (18) and the second (19, 22) electrode.

20. The device of claim 19, wherein the second electrode (19, 22) comprises a bottom electrode layer (22) arranged on a second side (21) of the substrate (17), said bottom electrode layer (22) having a larger extension than said top electrode layer (18).

21. The device of one of the claims 19 or 20, wherein the second electrode (19, 22) comprises a top electrode layer (19) arranged on the first side (20) of the substrate (17), said top electrode layer (19) being arranged around at least part, in particular substantially all, of the first electrode (18).

22. The device of one of the claims 16 to 21, wherein the first electrode (18) is elongate having a width much smaller than a length.

23. The device of one of the claims 16 to 22
5 comprising a first (4) and a second (6) signal path between the signal source (1) and the measuring circuit (7), wherein the first electrode (18) is arranged in the first signal path (4) and a reference load (R3) is arranged in the second signal path (6), and wherein the
10 measuring circuit (7) is adapted to measure a relative amplitude (A) and/or phase (ϕ) of signals from the first and second paths.

24. The device of one of the claims 16 to 23 wherein the first electrode (18) is part of a capacitor
15 (C) of a resonant circuit (5) comprising the capacitor (C) and an inductance (L) connected to the signal source (1).

25. The device of claim 24 wherein the capacitor (C) and the inductance (L) are arranged in series.
20

26. The device of one of the claims 24 or 25 wherein the measuring circuit (7) is adapted to measure a voltage over the resonant circuit (5).

27. The device of one of the claims 24 to 26
25 further comprising an antenna electrode (33) arranged in proximity to the first electrode (18), wherein the measuring circuit (7) is adapted to measure a signal transmitted from the first electrode (18) to the antenna electrode (33).

28. A device for determining the concentration of a substance in body liquid of a human body, in particular of one of the claims 15 to 26, comprising
30 an elongate first electrode (18) having a width much smaller than a length,
35 a holder (31) for fixing the first electrode (18) to an arm or leg of a body with a longitudinal axis

of the first electrode being substantially parallel to the arm or leg

a signal source connected to the first electrode applying a modulated electrical voltage to the
5 first electrode (18) for generating a modulated field in the specimen,

a measuring circuit (7) for measuring at least one parameter (A , ϕ , f_0) depending on a response of the specimen to the field, and

10 a data processor determining the concentration from the parameter.

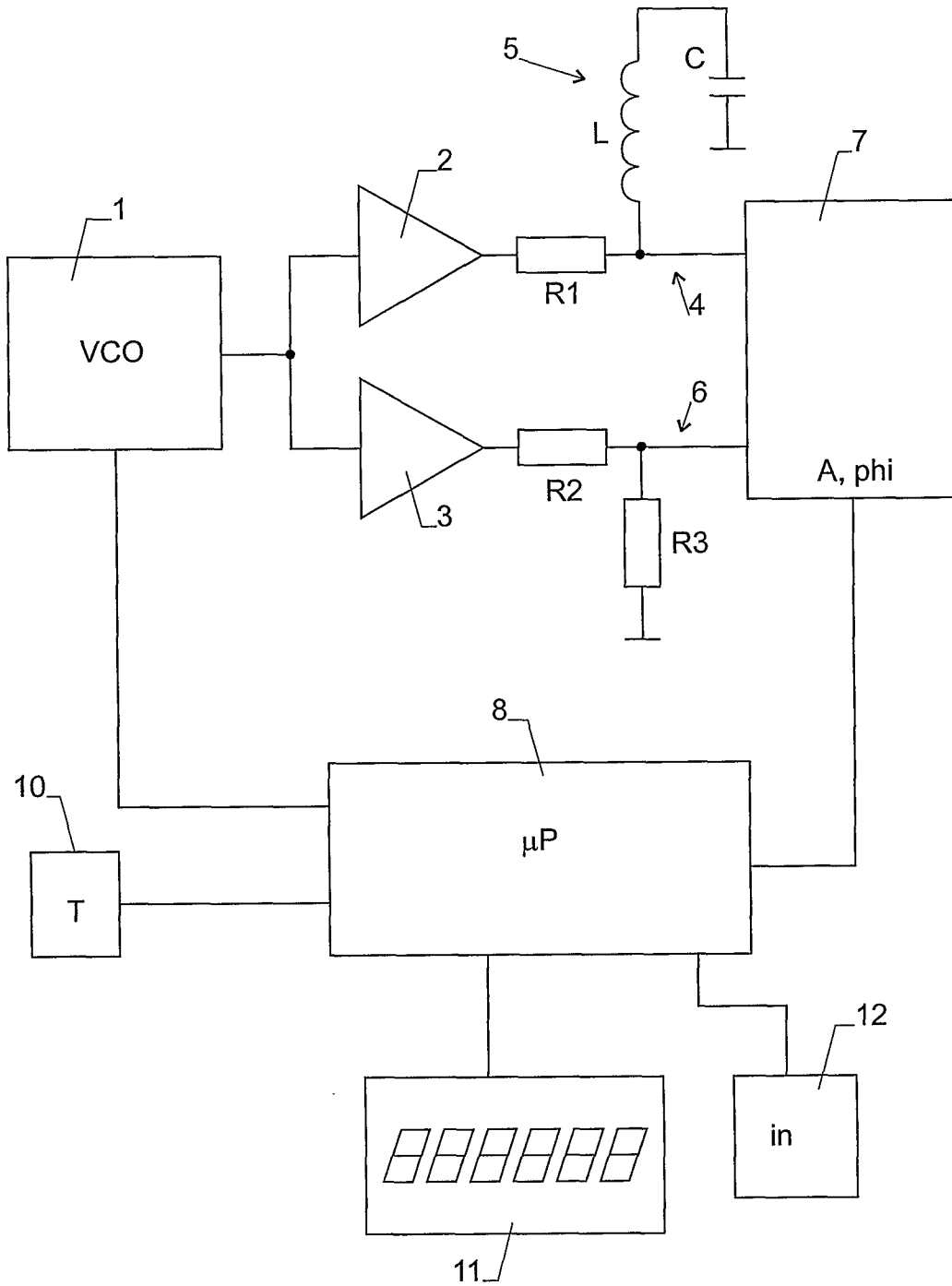

Fig. 1

2/4

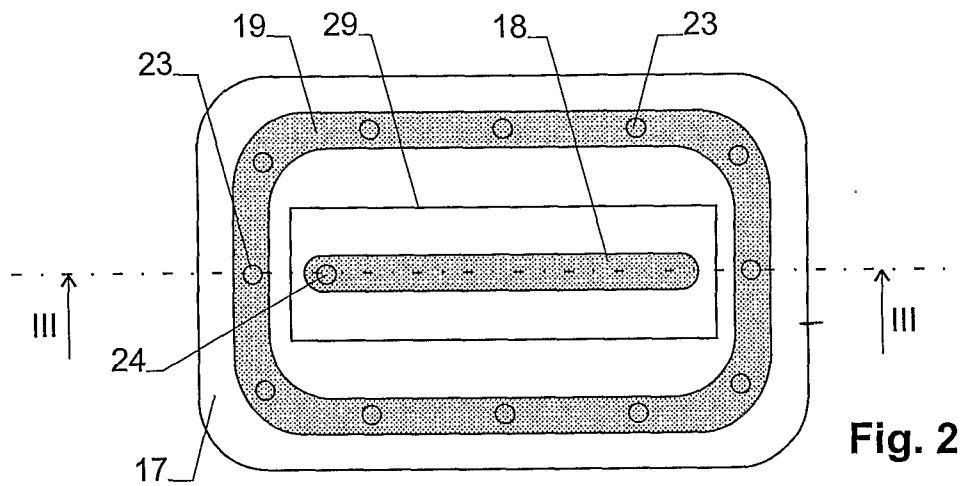

Fig. 2

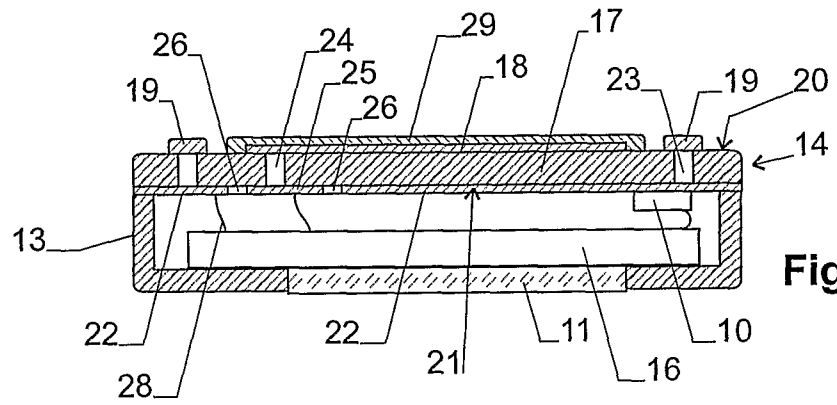

Fig. 3

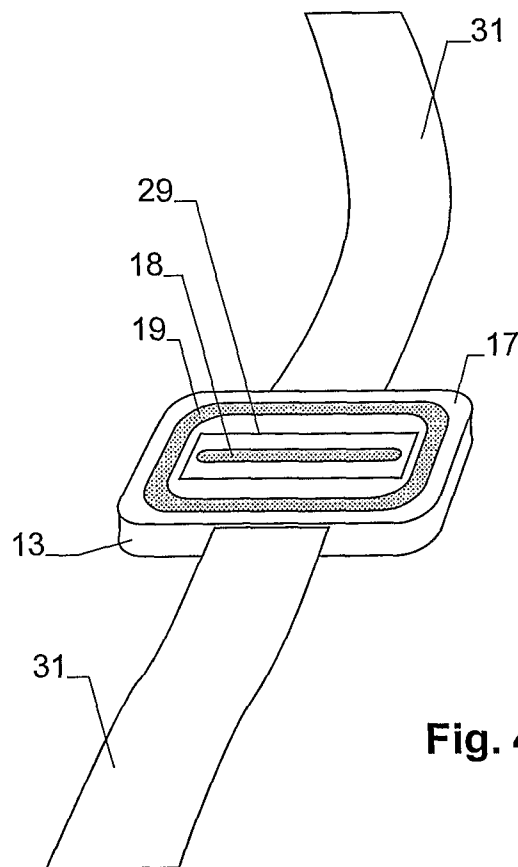

Fig. 4

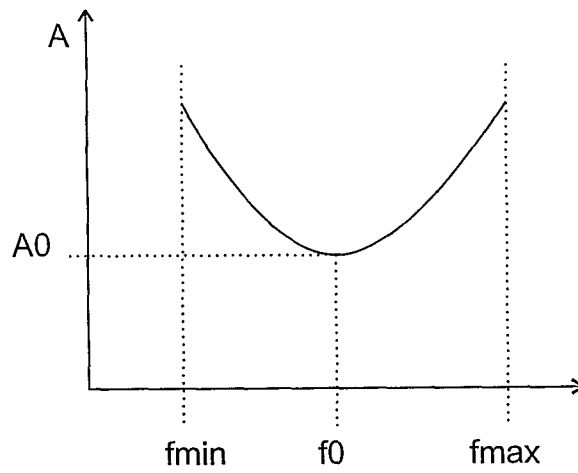

Fig. 5

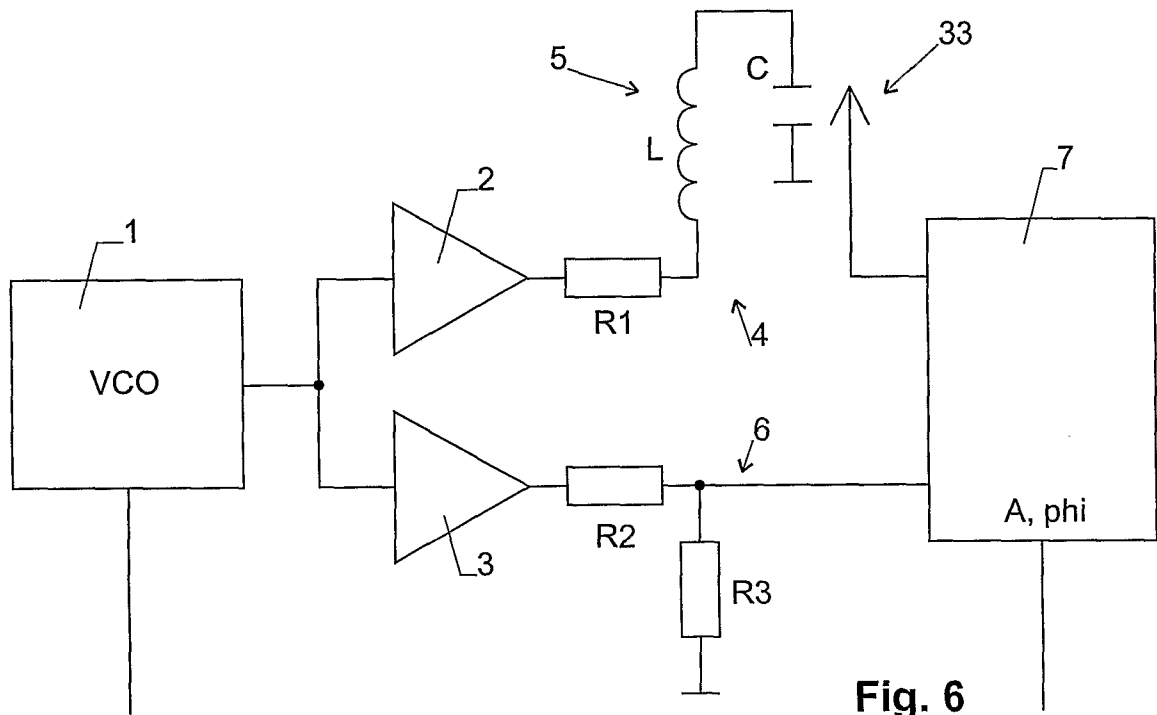

Fig. 6

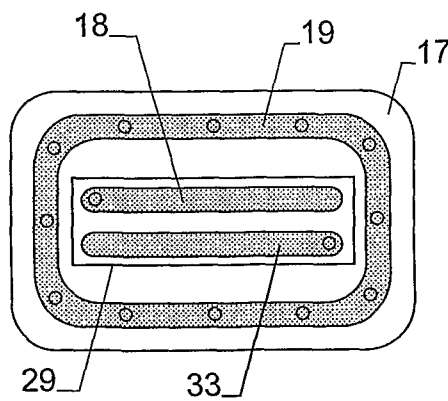

Fig. 7

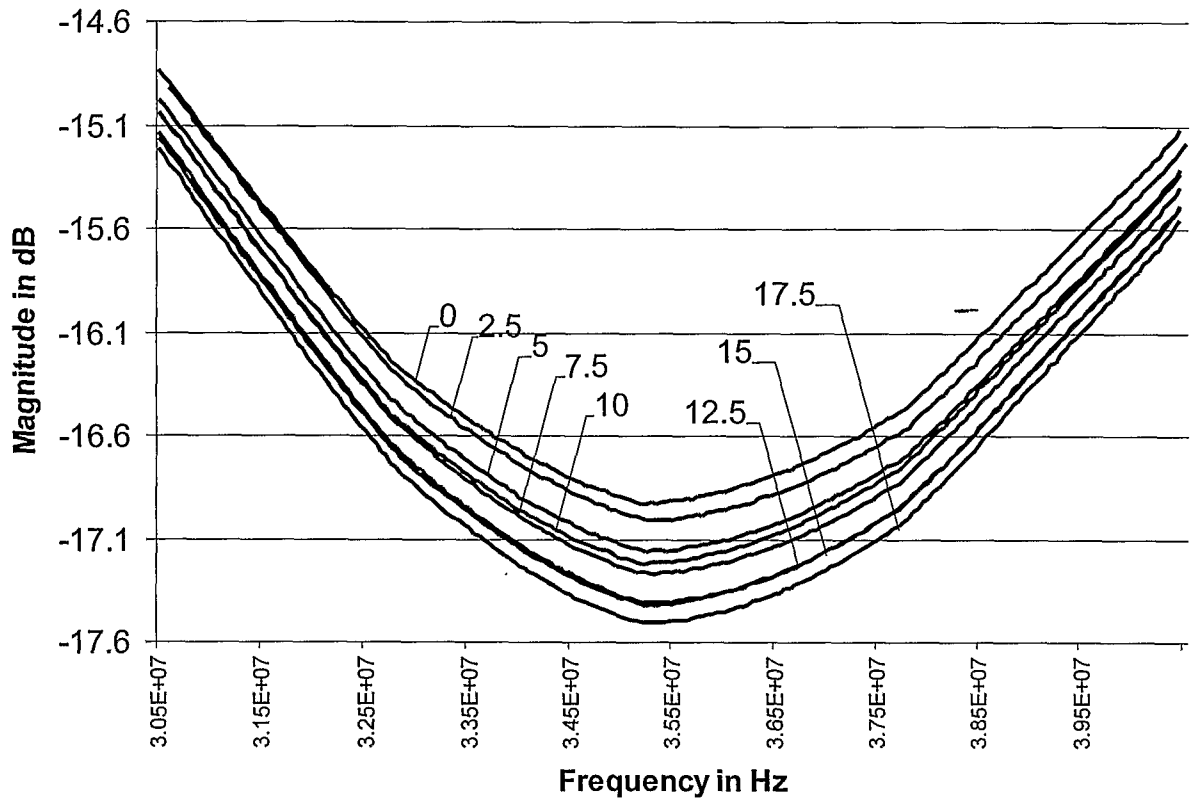

Fig. 8

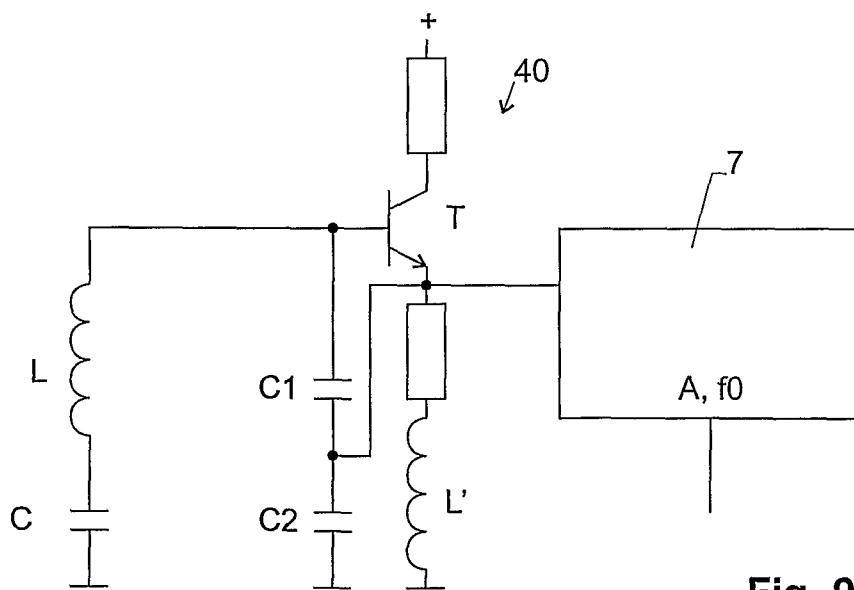

Fig. 9

INTERNATIONAL SEARCH REPORT

 International Application No
 PCT/IB 01/00334

 A. CLASSIFICATION OF SUBJECT MATTER
 IPC 7 A61B5/00 A61B5/05 G01N33/487 G01N22/00

According to International Patent Classification (IPC) or to both national classification and IPC

B. FIELDS SEARCHED

 Minimum documentation searched (classification system followed by classification symbols)
 IPC 7 A61B G01N

Documentation searched other than minimum documentation to the extent that such documents are included in the fields searched

Electronic data base consulted during the international search (name of data base and, where practical, search terms used)

EPO-Internal

C. DOCUMENTS CONSIDERED TO BE RELEVANT

Category °	Citation of document, with indication, where appropriate, of the relevant passages	Relevant to claim No.
A	US 5 792 668 A (DEAMER DAVID W ET AL) 11 August 1998 (1998-08-11) cited in the application abstract	16
A	WO 00 43759 A (LUCAS JAMES ;UNIV LIVERPOOL (GB); AL SHAMMAA AHMED (GB)) 27 July 2000 (2000-07-27) page 5 page 18; figure 17	16
A	EP 0 298 441 A (MED & TECH HANDELS GMBH) 11 January 1989 (1989-01-11) abstract; figure 1	16
A	EP 0 309 085 A (FISHER SCIENTIFIC CO) 29 March 1989 (1989-03-29) abstract	16
	-/--	

 Further documents are listed in the continuation of box C.

 Patent family members are listed in annex.

° Special categories of cited documents:

- *A* document defining the general state of the art which is not considered to be of particular relevance
- *E* earlier document but published on or after the international filing date
- *L* document which may throw doubts on priority claim(s) or which is cited to establish the publication date of another citation or other special reason (as specified)
- *O* document referring to an oral disclosure, use, exhibition or other means
- *P* document published prior to the international filing date but later than the priority date claimed

- *T* later document published after the international filing date or priority date and not in conflict with the application but cited to understand the principle or theory underlying the invention
- *X* document of particular relevance; the claimed invention cannot be considered novel or cannot be considered to involve an inventive step when the document is taken alone
- *Y* document of particular relevance; the claimed invention cannot be considered to involve an inventive step when the document is combined with one or more other such documents, such combination being obvious to a person skilled in the art.
- *Z* document member of the same patent family

Date of the actual completion of the international search

14 November 2001

Date of mailing of the international search report

21/11/2001

Name and mailing address of the ISA

 European Patent Office, P.B. 5818 Patentlaan 2
 NL - 2280 HV Rijswijk
 Tel. (+31-70) 340-2040, Tx. 31 651 epo nl,
 Fax: (+31-70) 340-3016

Authorized officer

Jonsson, P.O.

INTERNATIONAL SEARCH REPORT

tional Application No
PCT/IB 01/00334

C.(Continuation) DOCUMENTS CONSIDERED TO BE RELEVANT

Category *	Citation of document, with indication, where appropriate, of the relevant passages	Relevant to claim No.
A	US 4 509 531 A (WARD JOHN W) 9 April 1985 (1985-04-09) abstract; figures 1-3 ---	
A	WO 85 04481 A (HEALTH LAB SERVICE BOARD) 10 October 1985 (1985-10-10) abstract -----	

INTERNATIONAL SEARCH REPORT

Information on patent family members

International Application No

PCT/IB 01/00334

Patent document cited in search report		Publication date	Patent family member(s)	Publication date
US 5792668	A	11-08-1998	US 5508203 A	16-04-1996
			AU 731409 B2	29-03-2001
			AU 2974897 A	07-11-1997
			CA 2251919 A1	23-10-1997
			WO 9739341 A1	23-10-1997
			AU 676082 B2	27-02-1997
			AU 7520294 A	28-02-1995
			EP 0714259 A1	05-06-1996
			WO 9504496 A1	16-02-1995
WO 0043759	A	27-07-2000	AU 2115700 A	07-08-2000
			EP 1144985 A1	17-10-2001
			WO 0043759 A1	27-07-2000
			NO 20013603 A	13-09-2001
EP 0298441	A	11-01-1989	BR 8803351 A	17-01-1989
			EP 0298441 A2	11-01-1989
			ES 2048172 T3	16-03-1994
			AT 99148 T	15-01-1994
EP 0309085	A	29-03-1989	US 4751476 A	14-06-1988
			AU 1911388 A	23-03-1989
			EP 0309085 A2	29-03-1989
			JP 1132985 A	25-05-1989
US 4509531	A	09-04-1985	NONE	
WO 8504481	A	10-10-1985	AT 46219 T	15-09-1989
			AU 4213585 A	01-11-1985
			BR 8506431 A	15-04-1986
			CA 1239442 A1	19-07-1988
			DE 3572864 D1	12-10-1989
			DK 559785 A	03-12-1985
			EP 0176544 A1	09-04-1986
			WO 8504481 A1	10-10-1985
			HU 39015 A2	28-07-1986
			HU 200842 B	28-08-1990
			JP 5023624 B	05-04-1993
			JP 61501728 T	14-08-1986
			NO 854844 A	02-12-1985
			NO 164505 B	02-07-1990
			US 4876504 A	24-10-1989
			US 4810963 A	07-03-1989
ZA 8502504 A	27-11-1985			

专利名称(译)	用于确定体液中物质浓度的方法和装置		
公开(公告)号	EP1299029A1	公开(公告)日	2003-04-09
申请号	EP2001914075	申请日	2001-03-06
[标]申请(专利权)人(译)	潘卓冈医学公司		
申请(专利权)人(译)	PENDRAGON MEDICAL LTD.		
当前申请(专利权)人(译)	SOLIANIS HOLDING AG		
[标]发明人	SCHREPFER THOMAS W CADUFF ANDREAS HIRT ETIENNE SUSSTRUNK HEINZ		
发明人	SCHREPFER, THOMAS, W. CADUFF, ANDREAS HIRT, ETIENNE SÜSSTRUNK, HEINZ		
IPC分类号	G01N27/02 A61B5/00 A61B5/0408 A61B5/0478 A61B5/0492 A61B5/05 A61B5/053 A61B5/145 A61B5/1477 G01N27/22 G01N33/487 G01N22/00		
CPC分类号	A61B5/05 A61B5/053 A61B5/14532		
其他公开文献	EP1299029B1		
外部链接	Espacenet		

摘要(译)

为了测量体液中物质的浓度，例如血液或组织中的葡萄糖水平，在样本处设置条形电极（18）和环形电极（19）。环形电极（19）与样品直接电接触，而条形电极（18）与样品电绝缘。条形电极（18）平行于臂或腿布置，以获得大的相互作用长度。电极（18,19）在谐振电路中形成电容器。将接近或处于共振频率的MHz范围内的调制电压施加到电极，并测量体液的响应。该设计允许高精度的测量。