



(11) **EP 3 146 894 A1**

(12) **EUROPEAN PATENT APPLICATION**

(43) Date of publication:  
**29.03.2017 Bulletin 2017/13**

(51) Int Cl.:  
**A61B 5/00 (2006.01) A61B 5/11 (2006.01)**

(21) Application number: **15306502.4**

(22) Date of filing: **28.09.2015**

(84) Designated Contracting States:  
**AL AT BE BG CH CY CZ DE DK EE ES FI FR GB GR HR HU IE IS IT LI LT LU LV MC MK MT NL NO PL PT RO RS SE SI SK SM TR**  
Designated Extension States:  
**BA ME**  
Designated Validation States:  
**MA**

(72) Inventors:  
• **BARRAU, Coralie**  
**94220 CHARENTON-LE-PONT (FR)**  
• **ROUSSEAU, Denis**  
**94220 CHARENTON-LE-PONT (FR)**  
• **LORE, Marie**  
**94220 CHARENTON-LE-PONT (FR)**  
• **VILLETTE, Thierry**  
**94220 CHARENTON-LE-PONT (FR)**

(71) Applicant: **ESSILOR INTERNATIONAL**  
**(COMPAGNIE GENERALE D'OPTIQUE)**  
**94220 Charenton-le-Pont (FR)**

(74) Representative: **Cabinet Novitech**  
**188 Grande rue Charles de Gaulle**  
**94130 Nogent-sur-Marne (FR)**

(54) **A USER MIGRAINE ANALYSIS COMPONENT**

(57) The invention relates to a user migraine analysis component, comprising:  
- a memory configured to store computer executable instructions; and  
- a processor for executing the computer executable instructions, wherein the computer executable instructions

comprise instructions for:  
• receiving at least a visual behavior parameter indicative of the real time visual behavior of the user, and  
• determining the migraine risk of the user based on the analysis of the at least one visual behavior parameter.

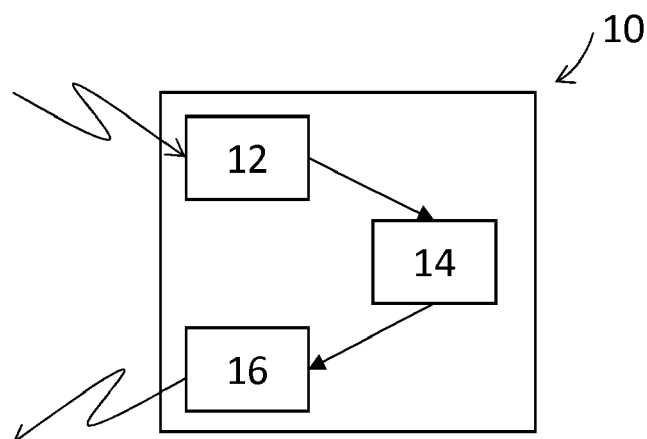

Figure 1

**EP 3 146 894 A1**

**Description**FIELD OF THE INVENTION

**[0001]** The invention relates to a user migraine analysis component and to a real-time visual behavior measuring device. The invention further relates to a system and a method for determining the migraine risk for a user.

BACKGROUND OF THE INVENTION

**[0002]** Migraines affect around 15% of the worldwide population. Half of migraine sufferers do not consult a physician when they feel impaired.

**[0003]** Thus, determining the risk of migraines for a user may be useful in many situations.

**[0004]** For example, some activities require a great degree of concentration. It is useful to be able to provide an indication of the migraine risk to the user carrying out such activity, or to a third party. Indeed, it has been observed that a change in behavior upon carrying out an activity may lead to very different results in terms of achievement of the activity.

**[0005]** Typically, when a person is driving it can be very useful to analyze the risk and the severity of migraine of the person so as to provide an alert when the risk or severity for a migraine is greater than a threshold value and driving represents a risk.

**[0006]** Therefore, there is a need for a device and a method for accurately determining the risk or the severity of migraine of a person.

**[0007]** One object of the present invention is to provide such a device and method.

SUMMARY OF THE INVENTION

**[0008]** To this end, the invention proposes a user migraine analysis component, comprising:

- a memory configured to store computer executable instructions; and
- a processor for executing the computer executable instructions, wherein the computer executable instructions comprise instructions for:
  - receiving at least one visual behavior parameter indicative of the real time visual behavior of the user, and
  - determining the migraine risk of the user based on the analysis of the at least one visual behavior parameter.

**[0009]** In particular, the memory may also be configured to store parameters.

**[0010]** Advantageously, determining the migraine risk of the user based on the analysis of at least one visual behavior parameter of the user provides a highly accurate estimate of the risk or the severity of migraine of the

user.

**[0011]** Indeed, the inventors have observed that the real time visual behavior of a person may be linked very precisely and accurately to the migraine risk of the user.

**[0012]** According to further embodiments which can be considered alone or in any combination:

- the visual behavior parameter relates at least to the eyelids activity of the user; and/or
- the computer executable instructions further comprise instructions for:
  - receiving real-time physiological data relating to at least one real time parameter of the physiology of the user, and
  - determining the migraine risk considering the real-time physiological data; and/or
- the real-time parameter of the physiology of the user relates to sweating of the user and/or the pulse of the user and/or the temperature of the user and/or the breathing rhythm of the user and/or muscle spasm of the user; and/or
- the computer executable instructions further comprise instructions for:
  - receiving real-time environment data relating to at least one real-time parameter of the environment of the user, and
  - determining the migraine risk considering the real-time environment data; and/or
- the real-time parameter of the environment of the user relates to the features of the light received by the user, said features comprising at least one of the temporal features, the spatial features, the spectral features, and the intensity of the light; and/or
- the real-time parameter of the environment of the user relates to temperature and/or the noise of the environment of the user and/or the time of the day; and/or
- the computer executable instructions further comprise instructions for:
  - receiving life habits data and/or health profile data relating to at least one parameter of the life habits of the user and/or to at least one parameter of the health profile of the user, and
  - adjusting the migraine risk based on the life habits data and/or on the health profile data; and/or
- the parameter of the life habits of the user relates to the food habits of the user and/or the physical activity habits of the user and/or the rhythm of life of the user, and the parameter of the health profile of the user relates to the professional situation of the user and/or the personal situation of the user and/or the general state of health of the user and/or the gender of the

user and/or the age of the user and/or the ongoing migraine treatment of the user; and/or

- the computer executable instructions further comprise instructions for:
  - o providing at least one migraine history parameter indicative of the migraine history of the user, and
  - o adjusting the migraine risk based on at least one migraine history parameter; and/or
- the parameter of migraine history is determined with measurements and/or with answers of the user to questionnaires.

**[0013]** The invention further relates to a real-time visual behavior measuring device comprising at least one sensor configured to measure in real time at least one visual behavior parameter indicative of the visual behavior of the user and a communication unit configured to communicate the measured real time visual behavior parameter to a user migraine analysis component according to the invention.

**[0014]** The real-time visual behavior measuring device may be a head mounted device arranged to be mounted on the head of the user.

**[0015]** The invention also relates to a system for determining the migraine risk of a user, the system comprising:

- a real-time visual behavior measuring device according to the invention, and
- a user migraine risk analysis component according to the invention.

**[0016]** The invention further relates to a method for determining the migraine risk for a user, the method comprising:

- a real-time visual behavior measuring step, during which at least one visual behavior parameter indicative of the visual behavior of the user is measured in real time, and
- an analyzing step, during which the migraine risk is determined based on the analysis of the at least one visual behavior parameter.

**[0017]** The invention further relates to a computer program product comprising one or more stored sequences of instructions that are accessible to a processor and which, when executed by the processor, causes the processor to carry out the steps of the method according to the invention.

**[0018]** The invention also relates to a computer-readable storage medium having a program recorded thereon; where the program makes the computer execute the method of the invention.

**[0019]** The invention further relates to a device com-

prising a processor adapted to store one or more sequence of instructions and to carry out at least one of the steps of the method according to the invention.

**[0020]** Unless specifically stated otherwise, as apparent from the following discussions, it is appreciated that throughout the specification discussions utilizing terms such as "computing", "calculating", or the like, refer to the action and/or processes of a computer or computing system, or similar electronic computing device, that manipulate and/or transform data represented as physical, such as electronic, quantities within the computing system's registers and/or memories into other data similarly represented as physical quantities within the computing system's memories, registers or other such information storage, transmission or display devices.

**[0021]** Embodiments of the present invention may include apparatuses for performing the operations herein. This apparatus may be specially constructed for the desired purposes, or it may comprise a general purpose computer or a Digital Signal Processor ("DSP") which can act as a general processor or a FPGA selectively activated or reconfigured by a computer program stored in the computer which can act as a co-processor when configured by a local processor or memory, or like a custom processor working alone and configured by local memory. Such a computer program may be stored in a computer readable storage medium, such as, but is not limited to, any type of disk including floppy disks, optical disks, CD-ROMs, magnetic-optical disks, read-only memories (ROMs), random access memories (RAMs) electrically programmable read-only memories (EPROMs), electrically erasable and programmable read only memories (EEPROMs), ferroelectric random access memories (FRAM), magnetic or optical cards, or any other type of media suitable for storing electronic instructions, and capable of being coupled to a computer system bus. The apparatus may also be a microcontroller, for example a chip comprising a central processing unit (CPU), a memory, sensors, and an interface for external sensors. All functions may be comprised in the same silicon chip, or in the same package with the system in package (SIP) technology, where several chips may be connected together inside the package.

**[0022]** The processes and displays presented herein are not inherently related to any particular computer or other apparatus. Various general purpose systems may be used with programs in accordance with the teachings herein, or it may prove convenient to construct a more specialized apparatus to perform the desired method.

**[0023]** The desired structure for a variety of these systems will appear from the description below. In addition, embodiments of the present invention are not described with reference to any particular programming language. It will be appreciated that a variety of programming languages may be used to implement the teachings of the inventions as described herein.

## BRIEF DESCRIPTION OF THE DRAWINGS

**[0024]** Embodiments of the invention will now be described, by way of example only, and with reference to the following drawings in which:

- Figure 1 is a schematic representation of a user migraine analysis component according to the invention;
- Figure 2 is an illustration of a chart-flow of a method according to the invention;
- Figure 3 is a representation of a real-time behavior measuring device according to the invention; and
- Figure 4 represents a global database synoptic for a user migraine analysis component according to the invention.

## DETAILED DESCRIPTION OF PREFERRED EMBODIMENTS

**[0025]** Elements in the figures are illustrated for simplicity and clarity and have not necessarily been drawn to scale. For example, the dimensions of some of the elements in the figure may be exaggerated relative to other elements to help improve the understanding of the embodiments of the present invention.

**[0026]** As illustrated in figure 1, the invention relates to a user migraine analysis component 10. The migraine analysis component may comprise:

- a communication module 12,
- a memory 14, and
- a processor 16.

**[0027]** The communication module 12 may be arranged to receive data. For example the data may be real-time visual behavior data indicative of a visual behavior parameter of the user of the migraine analysis component.

**[0028]** The real-time visual behavior data are typically measured by sensors and sent to the communication module 12. The sensors may be connected by wires to the communication module, or the communication may be wireless. The wireless communication can use different communication protocols such as Bluetooth, Zigbee, WiFi or others.

**[0029]** The communication module may further receive life habits data relating to at least one parameter of the life habits of the user of the migraine analysis component.

**[0030]** The communication module may further receive health profile data relating to at least one parameter of the health profile of the user of the migraine analysis component.

**[0031]** The communication module may also receive sleep history data indicative of at least one sleep quality parameter.

**[0032]** The life habits data and/or the sleep history data may be stored in a distant entity. The distant entity can

include different storing objects such as personal digital assistants, audio/video devices, mobile phones, MPEG-1 Audio Layer 3 (MP3) players, personal computers, laptops, tablets, Bluetooth headset, watch, wristband, etc...

**[0033]** The communication with the distant entity is usually wireless communication or via the Internet, for example with a WiFi interface. The distant entity can also include Web servers, file servers, media servers, etc. with which the communication module communicates via any of a number of known protocols, such as the hypertext transfer protocol (HTTP).

**[0034]** The memory 14 stores computer executable instructions that are to be executed by the processor 16.

**[0035]** The memory 14 may store life habits data relating to at least one parameter of the life habits of the user of the migraine analysis component.

**[0036]** The memory 14 may also store sleep history data indicative of at least one sleep quality parameter of the user of the migraine analysis component. The processor 16 is configured to execute at least part of the computer executable instructions stored in the memory 14.

**[0037]** The computer executable instructions comprise instructions for having the processor carry out a method of the invention.

**[0038]** As illustrated on figure 2, a method of the invention comprises at least:

- a real-time visual behavior parameter receiving step S10, and
- an analyzing step S20.

**[0039]** During the real-time visual behavior parameter receiving step S10, at least one visual behavior parameter indicative of the visual behavior of the user is received in real time. Typically, the visual behavior parameter is measured in real time by at least one sensor and the measured parameter is sent in real time to the user migraine analysis component.

**[0040]** For example, the visual behavior parameter may relate at least to the eyelids activity of the user, such as opening frequency and force or shift in the near point of convergence. As another example, the visual behavior parameter may relate at least to the eyebrows activity of the user, such as frequency and force of frown.

**[0041]** In the sense of the invention, "real-time" refers to the fact of measuring and sending the visual behavior parameter of the user at the same time or with a shift smaller than or equal to a few seconds.

**[0042]** During the analyzing step S20, the migraine risk is determined based on the analysis of the at least one visual behavior parameter.

**[0043]** As illustrated on figure 2, the method of the invention may further comprise:

- a real-time physiological data measuring step S 11, and/or
- a real-time environment data measuring step S12, and/or

- a life habits data and/or health profile data providing step S13.

**[0044]** During the real-time physiological data measuring step S11, real-time physiological data relating to at least one parameter of the physiology of the user are measured in real time. During the analyzing step S20, the migraine risk may be determined considering the real-time physiological data.

**[0045]** The real-time parameter of the physiology of the user may relate to sweating of the user and/or to the pulse of the user and/or to the temperature of the user and/or to the breathing rhythm of the user and/or to muscle spasm of the user.

**[0046]** The real-time environment of the user may also be considered when determining the migraine risk. During the real-time environment data measuring step S12, real-time environment data relating to at least one parameter of the environment of the user are measured in real time. During the analyzing step S20, the migraine risk may be determined considering the real-time environment data.

**[0047]** For example, the parameter of the environment of the user may relate to the features of the light received in real time by the user, said features comprising at least one of the temporal features, the spatial features, the spectral features, and the intensity of the light. In particular, in a bright environment, the migraine risk of the user may be increased.

**[0048]** Further parameters of the environment of the user may be considered as the temperature and/or the noise of the environment of the user and/or the time of the day.

**[0049]** Life habits of the user may be of interest when determining/predicting the migraine risk of the user. Moreover, the health profile of the user may affect the migraine risk of the user. During the life habits data and/or health profile data providing step S13, life habits data and/or health profile data respectively relating to at least one parameter of the life habits of the user and to at least one parameter of the health profile of the user are provided. During the analyzing step S20, the migraine risk is adjusted based on the life habits data and/or on the health profile data.

**[0050]** The health profile of the user typically relates to the professional situation of the user and/or the personal situation of the user and/or the general state of health of the user and/or the sex of the user and/or the age of the user and/or the ongoing migraine treatment of the user.

**[0051]** Typically, the life habits of the user relates to the food habits of the user and/or the physical activity habits of the user and/or the sleeping habits of the user and/or the rhythm of life of the user or any other life habits parameter that may have an influence on the migraine risk of the user.

**[0052]** The sleeping habits of the user may comprise sleep quality history of the user. For example, as illustrated on figure 2, the method of the invention may further

comprise a sleep quality history parameter providing step S 14, during which at least one sleep quality history parameter indicative of the sleep quality history of the user is provided to the user migraine analysis component.

5 During the analyzing step S20, the migraine risk is adjusted based on the at least one sleep quality history parameter.

**[0053]** The sleep quality history parameter may be determined through subjective indication provided by the user. For example, the user may provide each morning an indication on the sleep quality of the night such as a grade depending on the user's feeling of his sleep quality.

**[0054]** The sleep quality history may be determined using objective measurements relating to the user when sleeping. For example, the inventors have observed that a sleep quality history parameter relating to the sleep cycles efficiency history of the user is highly relevant when determining the risk of migraine of the user.

**[0055]** The sleep quality history parameter may relate at least to sleeping physiological data relating to at least one parameter of the physiology of the user upon sleeping.

**[0056]** The sleeping physiological data may for example be obtained by measuring the breathing of the user upon sleeping and/or the movement of the user upon sleeping and/or to the pulse of the user upon sleeping and/or the sound produced by the user upon sleeping. EEG (Electroencephalography) and REM (Rapid Eye Movement) analysis can be used also to analyze sleep quality. Waking up time relative to REM and/or paradoxal sleep is an important parameter for sleep quality and health.

**[0057]** The real-time head movement of the user may also be considered when determining the severity of the migraine. During the real-time head movement data measuring step, real-time head movement data relating to the movement of the head of the user are measured and provided in real time. During the analyzing step S20, the migraine risk may be adjusted considering the real-time head movement data.

**[0058]** Typically, real-time head movement may be linked to the level of pain of a user. For example, head tilt may provide indication of an increase pain level.

**[0059]** The environment of the user while sleeping may influence the sleep quality of the user. Therefore, according to an embodiment of the invention, the sleep quality history parameter relates at least to sleeping environment data relating to at least one parameter of the environment of the user upon sleeping.

**[0060]** For example, the parameter of the environment of the user upon sleeping may relates to the temperature of the sleeping environment of the user and/or the noise of the sleeping environment of the user and/or the features of the light of the sleeping environment of the user received by the user, said the light of the sleeping environment comprise at least one of the temporal features, the spatial features, the spectral features, the intensity of the light.

**[0061]** To increase the accuracy of the migraine risk determination, the light of the sleeping environment may be combined with the timing in the sleep cycle upon which such light is received by the user.

**[0062]** The method of the invention may further comprise a screen time providing step during which data representative of the time a user spent watching a screen are provided. During the analyzing step S20, such screen time data may be considered to determine more accurately the migraine risk of the user. Some flash or alternative light patterns can provoke migraine or epilepsy. Light sensors on the glasses can detect these light patterns.

**[0063]** The migraine history may be considered to determine more accurately the migraine risk of the user and to possibly update it. As illustrated on figure 2, the method of the invention may further comprise a migraine history parameter providing step S15 during which at least one migraine history parameter indicative of the migraine history of the user is provided. For example, the migraine history parameter may comprise data representative of the past level of pain of the user. During the analyzing step S20, the migraine risk is updated based on at least one migraine history parameter. In other words, the migraine risk may be adjusted based on at least one migraine history parameter.

**[0064]** For example, considering if the user has been having a high level of pain recently or not may be used to increase the accuracy of the method of the invention. So as to improve even more the accuracy and precision of the method of the invention, the method may comprise measuring and providing further real-time parameters.

**[0065]** The parameter of migraine history may be determined with measurements and/or with answers of the user to questionnaires. For example, the questionnaires may comprise questions about the frequency and the duration of the migraine. For example, the user may provide feedback concerning his current level of pain, for example using a scale of pain level.

**[0066]** The relevancy of each measured parameter may be adjusted based on the answers of the user to questionnaires, like with the MIDAS (Migraine Disability Assessment) score by scaling the severity of the migraine between grade I and grade IV.

**[0067]** Advantageously, such feedback makes it possible for a user to customize the analysis and therefore helps improve the accuracy of the method of the invention and/or the migraine analysis component.

**[0068]** The method of the invention may further comprise an information generating step S30 during which information based on said determined migraine risk of the user is generated.

**[0069]** The information may comprise a recommendation data based on the determined migraine risk of the user.

**[0070]** The information may further comprise an alert indicative of the determined migraine risk of the user.

**[0071]** The information may be induced according to a

score value calculated taking into account each parameters and their interactions, and/or values history, and/or calibrated normal parameters such as the minimum, the maximum, or critical values.

5 **[0072]** The information may be generated, for example, in the user migraine analysis component or in the distant entity.

**[0073]** As represented on figure 3, the invention further relates to a real-time visual behavior measuring device 20. The real-time visual behavior measuring device comprises at least one sensor configured to measure in real time at least one visual behavior parameter indicative of the visual behavior of the user and a communication unit 22 configured to communicate the measured real time visual behavior parameter to a user migraine analysis component 10 according to the invention.

10 **[0074]** In the example represented in figure 3, the real-time visual behavior measuring device 20 is a head mounted device comprising a frame intended to be mounted on the head of the user.

**[0075]** Furthermore, in the example of figure 3, the user migraine analysis component 10 is embedded in the real-time visual behavior measuring device 20.

15 **[0076]** The real-time visual behavior measuring device 20 may comprise different type of sensors depending on the type of real-time parameters that are to be considered.

**[0077]** Typically, the real-time visual behavior measuring device 20 may comprise a head movement detection sensor 24 that may comprise an accelerometer and/or gyroscope and/or compass configured to sense the orientation and position and variation of orientation and position of the head of the user.

20 **[0078]** The head movement detection sensor 24 may be placed on the frame 26 of the real-time visual behavior measuring device 20, as illustrated on Figure 3.

**[0079]** The real-time visual behavior measuring device 20 may further comprise an eye behavior sensor, such as an eye tracking device 28 arranged to measure eye movements, pupil diameter and activity of the user. Eye behavior also includes eyelid movement detection, which can be done by infrared emitting LED and infrared sensor.

25 **[0080]** A heart beat sensor (not shown) and skin sensor (not shown) can also be included. A heart beat sensor can be an optical sensor or any other type of heart beat sensor. Skin sensor can be skin moisture and/or skin resistivity sensors, which can give accurate information about the wearer stress or pain level.

**[0081]** EEG and EOG (Electrooculography) activity can also be measured by skin sensors. These parameters are useful for sleep analysis, and can be worn only during sleeping time.

30 **[0082]** The real-time visual behavior measuring device 20 may further comprise a light sensor 30 arranged to measure features of light, such as temporal, spectral and intensity features.

35 **[0083]** The real-time visual behavior measuring device 20 may further comprise a mapping system 32, such as

a GPS, arranged to provide features of the environment of the user.

**[0084]** The head mounted device 20 represented on figure 3 may also comprise two optical lenses 34. The optical lenses 34 may correspond to the optical prescription of the user. The optical lenses 34 may also be active lenses with an optical function which can be adapted for example to the user's needs. For example the lens may become darker if the light sensor detects a high luminosity and the monitoring system detects a risk of migraine due to high light condition.

**[0085]** The information based on the determined migraine risk of the user may be displayed on a display (not shown) of the head mounted device 20 or any other display in communication with the device that is configured to receive the information.

**[0086]** The communication unit 22 allows the local processor to receive information from different databases 100 illustrated on Figure 4. The communication unit 22 may allow the processor to receive information, for example stored in the user mobile phone 110 or in the cloud 120, containing parameters from external sensors 130 and/or health personal database 140, for example food habits, sleep quality or last risk exposure to migraine, that help the migraine analysis component to make the diagnostic of migraine risk and to provide an accurate decision and/or advice 180 for the user.

**[0087]** The communication unit 22 may also allow the processor to receive information containing experience or memorized parameters 150 and/or real time parameters 160 from embedded sensors 170, for example light, noise, temperature, eye movement, eyelid movement, activity, heartbeat of the user, blood pressure and oximetry of the user, time...

**[0088]** In another embodiment, the user migraine analysis component 10 may be in a distant entity communicating with the real-time visual behavior measuring device with the communication unit 22.

**[0089]** The distant entity can include different computing objects such as personal digital assistants, audio/video devices, mobile phones, MPEG-1 Audio Layer 3 (MP3) players, personal computers, laptops, tablets, Bluetooth headset, watch, wristband, etc.

**[0090]** The communication can be done through different communication devices and protocols, like Bluetooth, Zigbee, WiFi or others.

**[0091]** The invention has been described above with the aid of embodiments without limitation of the general inventive concept.

**[0092]** Many further modifications and variations will suggest themselves to those skilled in the art upon making reference to the foregoing illustrative embodiments, which are given by way of example only and which are not intended to limit the scope of the invention, that being determined solely by the appended claims.

**[0093]** In the claims, the word "comprising" does not exclude other elements or steps, and the indefinite article "a" or "an" does not exclude a plurality. The mere fact

that different features are recited in mutually different dependent claims does not indicate that a combination of these features cannot be advantageously used. Any reference signs in the claims should not be construed as limiting the scope of the invention.

## Claims

1. A user migraine analysis component (10), comprising:
  - a memory (14) configured to store computer executable instructions; and
  - a processor (16) for executing the computer executable instructions, wherein the computer executable instructions comprise instructions for:
    - receiving at least one visual behavior parameter indicative of the real time visual behavior of the user, and
    - determining the migraine risk of the user based on the analysis of the at least one visual behavior parameter.
2. The component according to claim 1, wherein the visual behavior parameter relates at least to the eyelids activity of the user.
3. The component according to claim 1 or 2, wherein the computer executable instructions further comprise instructions for:
  - receiving real-time physiological data relating to at least one real time parameter of the physiology of the user, and
  - determining the migraine risk considering the real-time physiological data.
4. The component according to claim 3, wherein the real-time parameter of the physiology of the user relates to one or more of: sweating of the user, the pulse of the user, the temperature of the user, the breathing rhythm of the user, and muscle spasm of the user.
5. The component according to any of the preceding claims, wherein the computer executable instructions further comprise instructions for:
  - receiving real-time environment data relating to at least one real-time parameter of the environment of the user, and
  - determining the migraine risk considering the real-time environment data.
6. The component according to claim 5, wherein the

real-time parameter of the environment of the user relates to the features of the light received by the user, said features comprising at least one of the temporal features, the spatial features, the spectral features, and the intensity of the light.

7. The component according to claim 5 or 6, wherein the real-time parameter of the environment of the user relates to one or more of: temperature, the noise of the environment of the user, and the time of the day.

8. The component according to any of the preceding claims, wherein the computer executable instructions further comprise instructions for:

- receiving life habits data and/or health profile data relating to at least one parameter of the life habits of the user and/or to at least one parameter of the health profile of the user, and
- adjusting the migraine risk based on the life habits data and/or on the health profile data.

9. The component according to claim 8, wherein the parameter of the life habits of the user relates to one or more of: the food habits of the user, the physical activity habits of the user, the sleeping habits of the user, and the rhythm of life of the user, and wherein the parameter of the health profile of the user relates to one or more of: the professional situation of the user, the personal situation of the user, the general state of health of the user, the gender of the user, the age of the user, and the ongoing migraine treatment of the user.

10. The component according to any of the preceding claims, wherein the computer executable instructions further comprise instructions for:

- providing at least one migraine history parameter indicative of the migraine history of the user, and
- updating the migraine risk based on at least one migraine history parameter.

11. The component according to claim 10, wherein the parameter of migraine history is determined with measurements and/or with answers of the user to questionnaires.

12. A real-time visual behavior measuring device (20) comprising at least one sensor configured to measure in real time at least one visual behavior parameter indicative of the visual behavior of the user and a communication unit (38) configured to communicate the measured real time visual behavior parameter to a user migraine analysis component according to any of claims 1 to 11.

5

10

15

20

25

30

35

40

45

50

55

13. The real-time visual behavior measuring device according to claim 12, wherein the real-time visual behavior measuring device (20) is a head mounted device arranged to be mounted on the head of the user.

14. A system for determining the migraine risk of a user, the system comprising:

- a real-time visual behavior measuring device (20) according to claim 12 or 13, and
- a user migraine risk analysis component (10) according to any of claims 1 to 11.

15. A method for determining the migraine risk for a user, the method comprising:

- a real-time visual behavior measuring step (S10), during which at least one visual behavior parameter indicative of the visual behavior of the user is measured in real time, and
- an analyzing step (S20), during which the migraine risk is determined based on the analysis of the at least one visual behavior parameter.

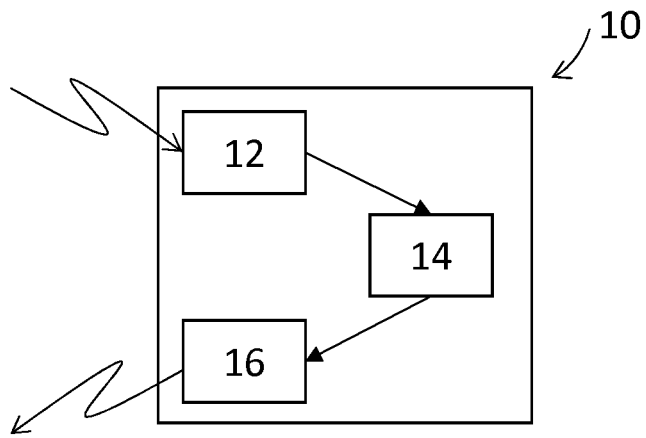

Figure 1

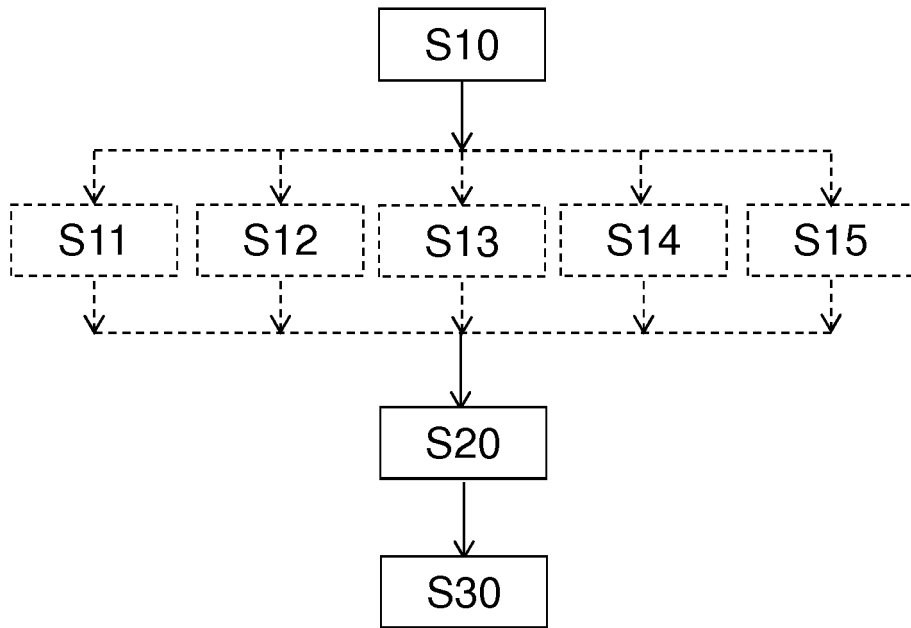

Figure 2

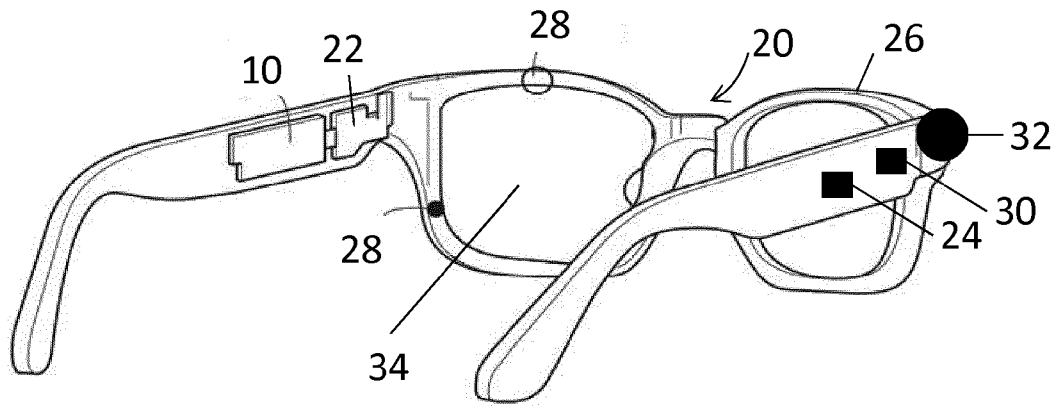

Figure 3

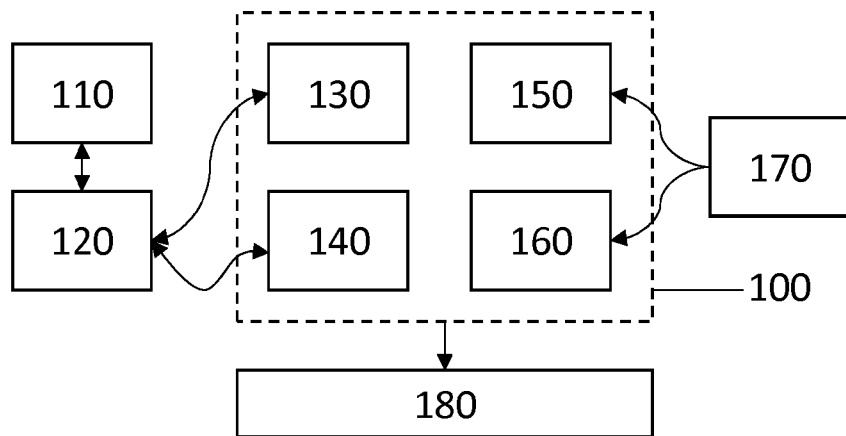

Figure 4



EUROPEAN SEARCH REPORT

Application Number  
EP 15 30 6502

5

10

15

20

25

30

35

40

45

50

55

DOCUMENTS CONSIDERED TO BE RELEVANT			
Category	Citation of document with indication, where appropriate, of relevant passages	Relevant to claim	CLASSIFICATION OF THE APPLICATION (IPC)
X	WO 2006/086086 A2 (CYBERKINETICS NEUROTECHNOLOGY [US]; FLAHERTY J CHRISTOPHER [US]) 17 August 2006 (2006-08-17)	1-4, 12-15	INV. A61B5/00 A61B5/11
Y	* abstract * * paragraphs [0050], [0091] - [0094]; claims 1,5,7,97,98,103; figures 1,4 *	5-11	
Y	WO 2006/017153 A2 (MONITRIX INC [US]; STUPP STEVEN [US]; CARPENTER CHRIS [US]; NEWMAN LAW) 16 February 2006 (2006-02-16)	5-11	
A	* abstract * * paragraphs [0006] - [0027], [0086], [0087], [0122] - [0148]; claim 1; figures 3,8-14 *	1-4,14, 15	
X	US 2001/028309 A1 (TORCH WILLIAM C [US]) 11 October 2001 (2001-10-11) * abstract * * paragraphs [0002], [0012]; figure 2 *	12,13	TECHNICAL FIELDS SEARCHED (IPC) A61B
A	US 2005/154419 A1 (WHITEHURST TODD K [US] ET AL) 14 July 2005 (2005-07-14) * the whole document *	1-15	
The present search report has been drawn up for all claims			
Place of search The Hague		Date of completion of the search 1 March 2016	Examiner Juárez Colera, M
CATEGORY OF CITED DOCUMENTS X : particularly relevant if taken alone Y : particularly relevant if combined with another document of the same category A : technological background O : non-written disclosure P : intermediate document		T : theory or principle underlying the invention E : earlier patent document, but published on, or after the filing date D : document cited in the application L : document cited for other reasons ..... & : member of the same patent family, corresponding document	

EPO FORM 1503 03 02 (P04C01)

ANNEX TO THE EUROPEAN SEARCH REPORT  
ON EUROPEAN PATENT APPLICATION NO.

EP 15 30 6502

5

This annex lists the patent family members relating to the patent documents cited in the above-mentioned European search report. The members are as contained in the European Patent Office EDP file on  
The European Patent Office is in no way liable for these particulars which are merely given for the purpose of information.

01-03-2016

10

Patent document cited in search report	Publication date	Patent family member(s)	Publication date
WO 2006086086 A2	17-08-2006	US 2006241356 A1 WO 2006086086 A2	26-10-2006 17-08-2006
-----	-----	-----	-----
WO 2006017153 A2	16-02-2006	EP 1765389 A2 US 2006015263 A1 US 2006080059 A1 US 2006270918 A1 US 2007179354 A1 US 2007179363 A1 US 2007219433 A1 US 2008108881 A1 US 2012036103 A1 WO 2006017153 A2	28-03-2007 19-01-2006 13-04-2006 30-11-2006 02-08-2007 02-08-2007 20-09-2007 08-05-2008 09-02-2012 16-02-2006
-----	-----	-----	-----
US 2001028309 A1	11-10-2001	NONE	
-----	-----	-----	-----
US 2005154419 A1	14-07-2005	NONE	
-----	-----	-----	-----

15

20

25

30

35

40

45

50

55

EPO FORM P0459

For more details about this annex : see Official Journal of the European Patent Office, No. 12/82

专利名称(译)	用户偏头痛分析组件		
公开(公告)号	<a href="#">EP3146894A1</a>	公开(公告)日	2017-03-29
申请号	EP2015306502	申请日	2015-09-28
[标]申请(专利权)人(译)	埃西勒国际通用光学公司		
申请(专利权)人(译)	ESSILOR INTERNATIONAL ( COMPAGNIE GENERALE D'OPTIQUE )		
当前申请(专利权)人(译)	ESSILOR INTERNATIONAL		
[标]发明人	BARRAU CORALIE ROUSSEAU DENIS LORE MARIE VILLETTE THIERRY		
发明人	BARRAU, CORALIE ROUSSEAU, DENIS LORE, MARIE VILLETTE, THIERRY		
IPC分类号	A61B5/00 A61B5/11		
CPC分类号	A61B5/7275 A61B5/11 A61B5/1103 A61B5/4058 A61B5/4094 A61B5/4815 A61B5/6803 A61B2560/0242 A61B2560/0462 G16H10/20 G16H10/60 G16H50/30		
外部链接	<a href="#">Espacenet</a>		

摘要(译)

本发明涉及一种用户偏头痛分析组件，包括：- 存储器，被配置为存储计算机可执行指令；- 用于执行计算机可执行指令的处理器，其中计算机可执行指令包括用于执行以下操作的指令：至少接收指示用户的实时视觉行为的视觉行为参数，以及基于用户确定用户的偏头痛风险。分析至少一个视觉行为参数。

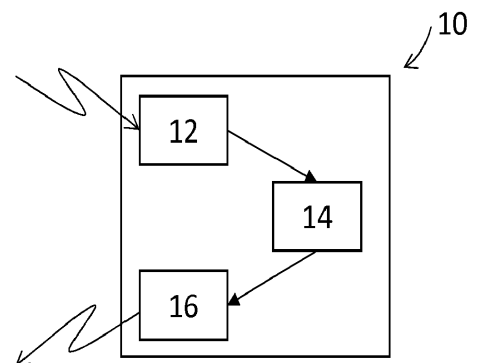

Figure 1